

# **BMS200/250 SHARPENER**

## **Safety, Operation, Maintenance & Parts Manual**

---

<b>BMS200</b>	<b>rev. B.07</b>
<b>BMS250</b>	<b>rev. B.07</b>

---



**Safety is our #1 concern!** Read and understand all safety information and instructions before operating, setting up or maintaining this machine.

*Form #944\_en*

**This is the original language  
for the manual.**

General Contact Information  
 Branches & Authorized Sales Centers Wood-Mizer Locations (North and South America)

<b>SECTION 1</b>	<b>SAFETY &amp; GENERAL INFORMATION</b>	<b>1-1</b>
1.1	Nomenclature .....	1-2
1.2	Electrical Safety.....	1-2
1.3	Blade Handling.....	1-3
1.4	Machine Operation .....	1-3
1.5	Sharpener Components.....	1-4
1.6	Overall Dimensions and Other Technical Data.....	1-5
1.7	Noise Level.....	1-6
1.8	Motor Specifications .....	1-6
1.9	Coolant Specifications.....	1-6
1.10	Control Panel Components.....	1-7
1.11	Warning Decals Description.....	1-10
<b>SECTION 2</b>	<b>SETUP &amp; OPERATION</b>	<b>2-1</b>
2.1	Machine Start.....	2-1
2.2	Blade Support and Cover Bumper Installation.....	2-2
2.3	Blade Height Adjustment .....	2-5
2.4	Grinding Wheel Installation .....	2-6
2.5	Blade Installation.....	2-8
2.6	Face Grind Adjustment.....	2-10
2.7	Grind Depth Adjustment .....	2-13
2.8	Feed Rate Adjustment .....	2-14
2.9	Magnetic Shut-off (not in BMS200, BMS250 EC Version).....	2-14
2.10	Blade Rejection .....	2-14
2.11	Operation Overview .....	2-15
2.12	Shutoff.....	2-15
2.13	2" Blade Sharpening.....	2-16
<b>SECTION 3</b>	<b>MAINTENANCE</b>	<b>3-1</b>
3.1	Grinding Wheel Replacement .....	3-1
3.2	Oil Level.....	3-1
<b>SECTION 4</b>	<b>PREPARING THE SHARPENER FOR SHARPENING VORTEX BLADES</b>	<b>4-1</b>
4.1	Grinding Wheel and Oiler Replacement .....	4-1
4.2	Cam Replacement.....	4-3
4.3	Blade Pusher Adjustment .....	4-5
4.4	Sharpener Head Adjustment.....	4-5
<b>SECTION 5</b>	<b>BMS200/BMS250 MAINTENANCE &amp; TROUBLESHOOTING</b>	<b>5-1</b>
5.1	Sharpener Maintenance .....	5-1
5.2	Blade Sharpening Tips .....	5-2

# Table of Contents

# Section-Page

<b>SECTION 6</b>	<b>ALIGNMENT</b>	<b>6-1</b>
6.1	Sharpener Head Stop Alignment.....	6-1
6.2	Sharpener Alignment.....	6-2
<b>SECTION 7</b>	<b>STANDARD OPERATING PROCEDURE</b>	<b>7-1</b>
7.1	Sharpening alignment: BMS 250 .....	7-2
7.2	Properly sharpened teeth .....	7-5
7.3	ReSharp process .....	7-7
<b>SECTION 8</b>	<b>REPLACEMENT PARTS</b>	<b>8-12</b>
8.1	How To Use The Parts List .....	8-12
8.2	Blade Support Assembly .....	8-13
8.3	Grinder Assembly.....	8-14
8.4	Sharpener Mounting Plate .....	8-17
8.5	Blade Clamp Assembly .....	8-18
8.6	Oil Pump/Pan, Control Box, BMS250 .....	8-20
8.7	Oil Pump/Pan, Control Box, BMS200 .....	8-22
8.8	Cam Assembly.....	8-24
8.9	Cover Assembly .....	8-26
8.10	Alignment tool&Blade ProfileTemplate .....	8-28

***Manufacturer Data:******Wood-Mizer Industries, Ltd.*****Nagórna 114****62-600 Koło****Poland****Tel. +48 63 26 26 000*****Wood-Mizer Products, Inc.*****8180 West 10th St.****Indianapolis, IN 46214****USA****Tel. 1-800-525-8100**

**IMPORTANT!** Read the entire Operator's Manual before operating the sharpener. Take notice of all safety warnings throughout this manual and those posted on the equipment. Keep this manual with this equipment at all times, regardless of ownership.

\*Wood-Mizer® is a registered trademark of Wood-Mizer Products, Inc.

## Getting Service

Wood-Mizer is committed to providing you with the latest technology, best quality and strongest customer service available on the market today. We continually evaluate our customers' needs to ensure we're meeting current wood-processing demands. Your comments and suggestions are welcome.

### *General Contact Information*

From Europe call your local distributor or our European Headquarters and Manufacturing Facility in Koło, Nagórna 114 St, Poland at **+48-63-2626000**. From the continental U.S., call our U.S. Headquarter 8180 West 10th St.Indianapolis, IN 46214, toll-free at **1-800-525-8100**. Ask to speak with a Customer Service Representative. Please have your machine identification number and your customer number ready when you call. The Service Representative can help you with questions about the operation and maintenance of your machine. He also can schedule you for a service call.

### **Office Hours:**

<b>Country</b>	<b>Monday - Friday</b>	<b>Saturday</b>	<b>Sunday</b>
Poland	7 a.m.- 3 p.m.	Closed	Closed
US	8 a.m.- 5 p.m.	8 a.m.- 12 p.m	Closed

Please have your vehicle identification number and your customer number ready when you call.

Wood-Mizer will accept these methods of payment:

- Visa, Mastercard, or Discover
- COD
- Prepayment
- Net 15 (with approved credit)



Be aware that shipping and handling charges may apply. Handling charges are based on size and quantity of order.

Technical data are subject to change without prior notice.

Actual product may differ from product images. Some illustrations show machines with optional equipment.

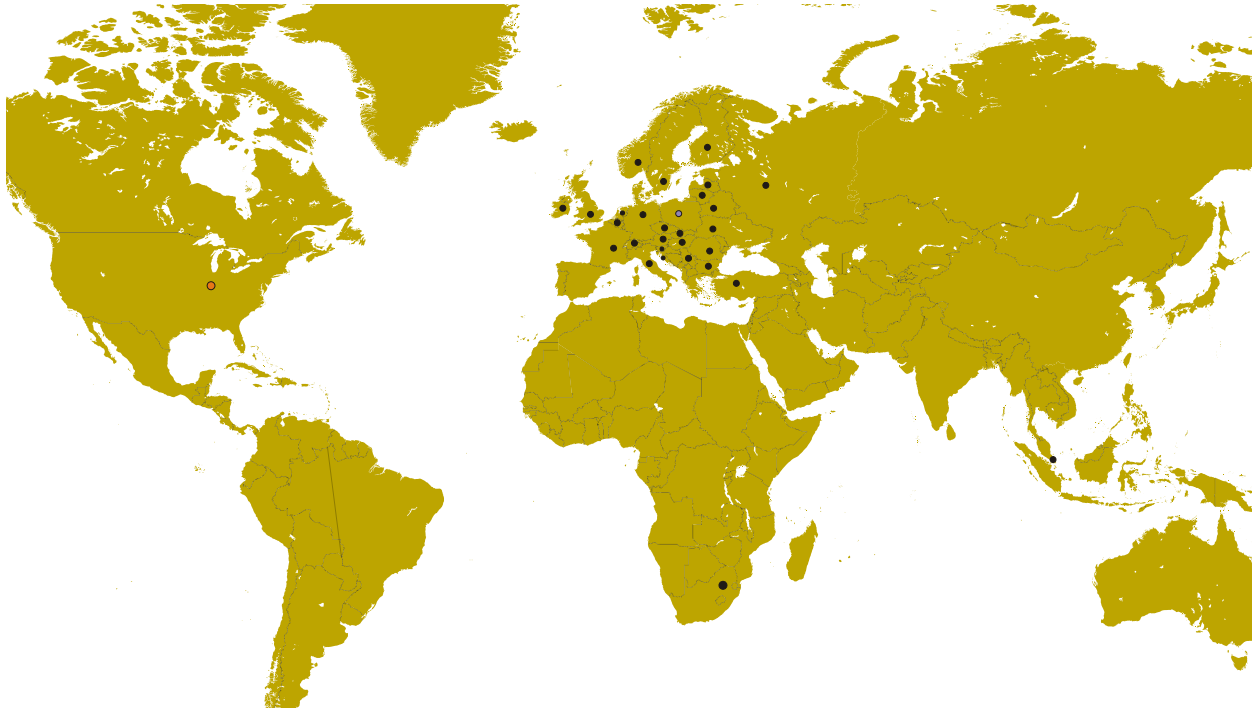
**Branches & Authorized Sales Centers Wood-Mizer Locations (North and South America)**



EUROPE		UNITED STATES
<p> <b>European Headquarters</b>  <b>Wood-Mizer Industries Sp. z o.o.</b>                      Nagórna 114, 62-600 Kolo, Poland                      Tel.: +48-63-26-26-000                      Fax: +48-63-27-22-327  <a href="http://www.woodmizer.eu">www.woodmizer.eu</a></p>		<p> <b>World Headquarters</b>  <b>Wood-Mizer LLC</b>                      8180 West 10th Street                      Indianapolis, Indiana 46214-2400,                      USA                      Tel.: +1-317-271-1542                      Fax: +1-317-273-1011  <a href="http://www.woodmizer.com">www.woodmizer.com</a></p>
<p><b>BELARUS</b>  <b>MOST-GRUPP</b>                      Siemashko 15, k.3                      Minsk 2200116                      Tel.: +375-17-270-90-08                      Fax: +375-17-270-90-08                      GSM: +375-29-649-90-80                      e-mail: <a href="mailto:most-by@mail.ru">most-by@mail.ru</a></p>	<p><b>SWITZERLAND Stefan Wespi</b>                      Maschinen u. Geräte                      Spezialarbeiten GmbH                      Eichstraße 4                      6353 Weggis                      Tel.: +41-413-900-312                      GSM: +41-799-643-594  <a href="mailto:info@woodmizer.ch">info@woodmizer.ch</a>  <a href="http://www.woodmizer.ch">www.woodmizer.ch</a></p>	<p><b>RUSSIA Dariusz Mikołajewski</b>  <b>OOO WOOD-MIZER INDUSTRIES</b>                      141031, Moscow                      Reg., Mytishenski raj., pos. Veshki,                      Zavodskaja str., 3B                      Tel.Fax: +7(495) 788-72-35                      Tel.Fax: +7(495) 641-51-60                      e-mail: <a href="mailto:dariuszm@woodmizer-moscow.ru">dariuszm@woodmizer-moscow.ru</a></p>
<p><b>BULGARIA Kalin Simeonov</b>  <b>Ecotechproduct</b>                      38 Star Lozenski pat str.                      Sofia 1186                      Tel.: +359-2-462-7035                      Tel.: +359-2-963-1656                      Tel./Fax                      : +359-2-979-1710  <b>Kalin Simeonov</b>                      GSM: +3592-963-2559                      e-mail: <a href="mailto:office@ecotechproduct.com">office@ecotechproduct.com</a></p>	<p><b>HUNGARY Wiktor Turoczy</b>  <b>Wood-Mizer Hungary K.F.T.</b>                      Szonyi Ut 67., 2921 Komárom                      Tel./Fax: +36-34-346-255                      e-mail: <a href="mailto:woodmizer@woodmizer.hu">woodmizer@woodmizer.hu</a></p>	<p><b>RUSSIA Far East Wladimir Glazaczew</b>  <b>"WM Service"</b>                      Krasnoretchenskaya Str.111                      680006 Khabarovsk                      Tel./Fax: +7-914-541-1183                      e-mail: <a href="mailto:wms-khv@mail.ru">wms-khv@mail.ru</a></p>

<p><b>CROATIA Krešimir Pregernik</b>  <b>Pregimex d.o.o.</b>  S. Batušićeva 31, 10090 Zagreb  Tel./Fax: +3851-38-94-668  <b>Krešimir Pregernik</b>  GSM: +3851-98-207-106  e-mail: <a href="mailto:Kresimir.Pregernik@gmail.com">Kresimir.Pregernik@gmail.com</a></p>	<p><b>ITALY Pasquale Felice</b>  <b>Wood-Mizer Italia Srl</b>  <b>Cda. Capoiaccio SN</b>  86012 Cercemaggiore  Campobasso  Tel./Fax: +39-0874-798-357  GSM: +39-333-281-03-79  e-mail: <a href="mailto:wmitaliasrl@gmail.com">wmitaliasrl@gmail.com</a></p>	<p><b>SERBIA Dragan Markov</b>  <b>Wood-Mizer Balkan d.o.o.</b>  Svetosavska GA 3/3; P. Fah 25  23 300 Kikinda  Tel./Fax: +381-230-25-754  Tel./Fax: +381-230-23-567  GSM: +381-63-568-658  e-mail: <a href="mailto:office@woodmizer.co.yu">office@woodmizer.co.yu</a></p>
<p><b>CZECH REPUBLIC Miroslav Greill</b>  <b>Wood-Mizer CZ s.r.o.</b>  Za Kasárny 946  339 01 Klatovy  tel: +420-376-312-220  <b>Greill Miroslav</b>  GSM: +420 602-439-799  e-mail: <a href="mailto:woodmizer@woodmizer.cz">woodmizer@woodmizer.cz</a></p>		<p><b>SLOVAKIA Wiktor Turoczy</b>  <b>Wood-Mizer Danubia s.r.o.</b>  Hadovce 5, 94501 Komárno  Tel.: +421-35-77-40-316  Fax: +421-35-7740-326  GSM: +421-905-930-972  e-mail: <a href="mailto:woodmizer@woodmizer.sk">woodmizer@woodmizer.sk</a></p>
<p><b>CZECH REPUBLIC Lubomir Kudlik</b>  <b>Wood-Mizer Moravia</b>  Sovadinova 6  69002 Breclav  Tel./Fax: +420-519-322-443  <b>Lubomir Kudlik</b>  GSM: +420-602-734-792  e-mail: <a href="mailto:info@wood-mizer.net">info@wood-mizer.net</a></p>	<p><b>LATVIA Vilmars Jansons</b>  <b>OBERTS Ltd</b>  Gaujas str. 32/2  LV-2167 Marupe, Rigas Raj.  Tel.: +371-7-810-666  Fax: +371-7-810-655  <b>Vilmars Jansons</b>  GSM: +371-92-06-966  <b>Andris Orols</b>  GSM: +371-28-33-07-90  e-mail: <a href="mailto:andris@oberts.lv">andris@oberts.lv</a></p>	<p><b>TURKEY</b>  <b>Er-Ka Ahsap Profil Kerestecilik San. ve Tic. Ltd. Sti.</b>  Adana Keresteciler Sitesi 191 sk No.41  ADANA  Tel.: +90-322-346-15-86  Fax: +90-322-345-17-07  GSM: +90-533-363-18-44  e-mail: <a href="mailto:info@erkaahsap.com.tr">info@erkaahsap.com.tr</a></p>
<p><b>FINLAND Howard Blackburn</b>  <b>Oy Falkberg Jordbruk Ab</b>  Falkintie 220  25610 Ylonkyla  Tel.: +358-2732-2253  Fax: +358-2732-2263  <b>Howard Blackburn</b>  GSM: +358-440-424-339  e-mail: <a href="mailto:falkberg@woodmizer.fi">falkberg@woodmizer.fi</a></p>	<p><b>LITHUANIA Andrius Zuzevicius</b>  <b>UAB Singlis</b>  Savanoriu pr. 187, 2053 Vilnius  Tel.: +370-5-2-32-22-44  Fax: +370-5-2-64-84-15  GSM: +370-620-28-645  e-mail: <a href="mailto:andrius.z@singlis.lt">andrius.z@singlis.lt</a></p> <p><b>Dmitrij Gaiduk</b>  GSM: +370-69-84-51-91  e-mail: <a href="mailto:dmitrijus.g@singlis.lt">dmitrijus.g@singlis.lt</a></p>	<p><b>UKRAINE Ivan Vinnicki</b>  <b>MOST UKRAINA</b>  bul. Myru 3, Bajkivtsi Ternoplskyj r-j  Ternopolska oblast  47711 Ukraine  Tel/Fax: +38 (0352) 52 37 74  GSM: +38 (067) 352 54 34  GSM: +38 (067) 674 50 68  E-mail: <a href="mailto:most-ukraine@ukr.net">most-ukraine@ukr.net</a></p>
<p><b>FRANCE Tizoc Chavez</b>  Wood-Mizer France  556 chemin des Embouffus,  ZAC des Basses Echarrieres  38440 SAINT JEAN DE BOURNAY  Tel: +33-4 74 84 84 44  GSM: +33-607 52 02 82  Mail: <a href="mailto:tchavez@woodmizer.fr">tchavez@woodmizer.fr</a></p>	<p><b>NORWAY Tor Bakken Flaathe</b>  Bakken Flaathe A/S  Løkenvegen 5, 2034 Holter  Tel: + 47-638 74 989  Sales: + 47- 412 80 076  Service: +47- 975 87 588  <a href="mailto:post@woodmizer.no">post@woodmizer.no</a>  <a href="http://www.woodmizer.no">www.woodmizer.no</a></p>	<p><b>UNITED KINGDOM &amp; IRELAND</b>  <b>Wood-Mizer UK</b>  Hopfield Barn  Kenward Road, Yalding  Kent ME18 6JP, UK  Tel.: +44-1622-813-201  Fax: +44-1622-815-534  e-mail: <a href="mailto:info@woodmizer.co.uk">info@woodmizer.co.uk</a></p>
<p><b>SLOVENIA Jan Fale</b>  <b>FAMTEH d.o.o.</b>  Gacnikova pot 2,  2390 Ravne na Koroskem  Tel.: +386-2-62-04-232  Fax: +386-2-62-04-231  <b>Jan Fale</b>  GSM: +386-2-62-04-230  e-mail: <a href="mailto:jan.fale@famteh.si">jan.fale@famteh.si</a></p> <p><b>Matjaz Kolar</b>  Tel.: +386-2-62-04-232  GSM: +386-31-775-999  e-mail: <a href="mailto:matjaz.kolar@famteh.si">matjaz.kolar@famteh.si</a></p>		

<p><b>GERMANY/AUSTRIA Klaus Longmuss</b>  <b>Wood-Mizer GmbH</b>  Dorfstraße 5, 29485 Schletau  <b>Büro</b>  Tel: +49-5883 988 010  <b>Werkstatt</b>  Tel: +49-5883 988 220  <b>Ersatzteilservice</b>  Tel: +49 58 83 - 98 80 250  <b>Schärfservice</b>  Tel: +49-58 83 - 98 80 270  <b>E-mail:</b>  <a href="mailto:info@woodmizer.de">info@woodmizer.de</a>  <a href="http://www.woodmizer.de">www.woodmizer.de</a>  <b>Klaus Longmuss</b>  Tel.: +49-5883-9880-12  GSM: +49-17-298-55-892  e-mail: <a href="mailto:KLongmuss@woodmizer.de">KLongmuss@woodmizer.de</a></p>	<p><b>Subagent:</b>  <b>SWEDEN Kjell Larsson</b>  <b>Mekwood AB</b>  Slingan 14, 812 41 Gästrike-Hammarby  Tel.: +46-290-515-65  <b>Kjell Larsson</b>  GSM: +46-706-797-965  e-mail: <a href="mailto:kjell.larsson@mekwood.se">kjell.larsson@mekwood.se</a></p>	<p><b>IRELAND</b>  <b>Wood-Mizer Ireland</b>  Stephen Brennan  Cum Lahardane Ballina County Mayo  Tel:+353 96 51345   E-mail: <a href="mailto:brennanmill@ericom.net">brennanmill@ericom.net</a></p>
<p><b>Subagents:</b>  <b>DENMARK Kevin Christiansen</b>  Kevin Christiansen's  savværker PMV  Arnborgvej 40, 7330 Brande- Fasterholt   Mobile: +45 61468763  Mobile: +45-23495828  <a href="mailto:Info@woodmizer.dk">Info@woodmizer.dk</a>  www.woodmizer.dk</p>	<p><b>ROMANIA Adrian Echert</b>  <b>SC WOOD-MIZER RO SRL</b>  TRANSILVANIEI Nr. 5  Sibiu, Cisanadie 555300  Tel./Fax: : +40-369-405-433  GSM: +40-745-707-323  e-mail: <a href="mailto:aechert@woodmizer.ro">aechert@woodmizer.ro</a></p>	<p>Regional Manager - Asia  Robert Moxham  Regional Direction - Asia  Wood-Mizer Asia Manufacturing Co., Ltd.  No.2, Gongyequ 40th Rd. Xitun District,  Taichung City, 40768, Taiwan, R.O.C.  TEL: +886-4-2359 3022  FAX: +886-4-2359 3205  CELL: +886-9-0568 7708  EMAIL: <a href="mailto:RMoxham@woodmizer.com">RMoxham@woodmizer.com</a>  <a href="http://www.woodmizerasia.com">www.woodmizerasia.com</a>  Skype: r.g.moxham</p>
<p><b>NETHERLANDS Gerlo Breukers</b>  Breukers Houtzagerij en Bosbouwmachines  Hazenweg 5, 7481 PC Haaksbergen  Tel: +31-535741326  Mobile: +31-620419412  <a href="mailto:info@woodmizer.nl">info@woodmizer.nl</a>  <a href="http://www.woodmizer.nl">www.woodmizer.nl</a></p>	<p><b>Subagent:</b>  <b>ROMANIA M. Echert</b>  <b>S.C. Echert Comprod s.r.l</b>  Str. Schitului Nr. 6, Apt.7 etajul-1  725 70 Vatra Dornei, Romania  Tel./Fax: +40-230-374-235  Tel. : +40-740-35-35-74</p>	<p>Regional Manager - Africa  Gavin Prowse  Regional Sales Director - Africa  Wood-Mizer Africa (Pty) Ltd.  Unit 1, Leader Park  20 Chariot Street  Stormill Ext.5  Maraisburg, Johannesburg  South Africa  TEL: +27 11 473 1313  FAX: +27 11 473 2005  CELL: +27 71 398 8010  EMAIL: <a href="mailto:growse@woodmizer.com">growse@woodmizer.com</a>  <a href="http://www.woodmizerafrika.com">www.woodmizerafrika.com</a>  Skype: gavin.prowse</p>

## USA World Headquarters

*Serving North & South America, Oceania, East Asia*

Wood-Mizer LLC  
8180 West 10th Street  
Indianapolis, IN 46214

Phone: 317.271.1542 or 800.553.0182  
Customer Service: 800.525.8100  
Fax: 317.273.1011  
Email: [infocenter@woodmizer.com](mailto:infocenter@woodmizer.com)

## Brazil Headquarters

*Serving Brazil*

Wood-Mizer do Brasil  
Rua Dom Pedro 1, No: 205 Bairro: Sao Jose  
Ivoti/RS CEP:93.900-000

Tel: +55 51 9894-6461/ +55 21 8030-3338/ +55 51 3563-4784  
Email: [info@woodmizer.com.br](mailto:info@woodmizer.com.br)

## Canadian Headquarters

*Serving Canada*

Wood-Mizer Canada  
396 County Road 36, Unit B  
Lindsay, ON K9V 4R3

Phone: 705.878.5255 or 877.357.3373  
Fax: 705.878.5355  
Email: [ContactCanada@woodmizer.com](mailto:ContactCanada@woodmizer.com)

## Europe Headquarters

*Serving Europe, Africa, West Asia*

Wood-Mizer Industries Sp z o.o.  
Nagorna 114  
62-600 Kolo, Poland

Phone: +48.63.26.26.000  
Fax: +48.63.27.22.327

## Branches & Authorized Sales Centers

For a complete list of dealers, visit [www.woodmizer.com](http://www.woodmizer.com)



### SECTION 1 SAFETY & GENERAL INFORMATION



This symbol calls your attention to instructions concerning your personal safety. Be sure to observe and follow these instructions. This symbol accompanies a signal word. The word **DANGER** indicates an imminently hazardous situation which, if not avoided, will result in death or serious injury. **WARNING** suggests a potentially hazardous situation which, if not avoided, could result in death or serious injury. **CAUTION** refers to potentially hazardous situations which, if not avoided, may result in minor or moderate injury to persons or equipment. Read all safety instructions before operating this equipment and observe all safety warnings!



Warning stripes are placed on areas where a single decal would be insufficient. To avoid serious injury, keep out of the path of any equipment marked with warning stripes.

Read and observe all safety instructions before operating this equipment! Also read any additional manufacturer's manuals and observe any applicable safety instructions including dangers, warnings, and cautions.

Always be sure that all safety decals are clean and readable. Replace all damaged safety decals to prevent personal injury or damage to the equipment. Contact your local distributor, or call your Customer Service Representative to order more decals.

Always properly dispose of all by-products, including debris, coolant and oil.

Safety instructions are listed in this section by the following operations:

- Electrical Safety
- Blade Handling
- Machine Operation

# 1 Safety & General Information

## Nomenclature

### 1.1 Nomenclature

Machine Name	Version	Electric Standards Code		Voltage Code	
BMS	200	S	50Hz EU standards	A	230V 1ph

TABLE 1-1

Possible combinations:

Model	Version	Voltage code	Standard code	Description
BMS	200	M	U	Sharpener / economy /1x110V 60Hz/ UL
BMS	200	A		Sharpener / economy /1x230V 50Hz/
BMS	200	A	U	Sharpener / economy /1x230V 60Hz/ UL
BMS	250	M	U	Sharpener / personal /1x110V 60Hz/ UL
BMS	250	A	U	Sharpener / personal /1x230V 60Hz/ UL
BMS	250	A	S	Sharpener / personal /1x230V 50Hz/ CE

### 1.2 Electrical Safety



**DANGER!** Make sure all electrical installation, service and/or maintenance work is performed by a qualified electrician and is in accordance with applicable electrical codes.

**DANGER!** HAZARDOUS VOLTAGE can cause shock, burns, or death. SHUT OFF & LOCK OUT POWER before performing service in any area of this machine. DO NOT restore power until all access panels are replaced and secured.



**WARNING!** Always turn off and disconnect power at control console AND at main supply circuit breaker before performing any service to the machine.



**DANGER!** It is recommended that a 30mA Ground Fault Interrupter (GFI) be used.

### 1.3 Blade Handling



**WARNING!** Always wear gloves and eye protection when handling bandsaw blades. Keep all persons away from area when coiling or carrying a blade (4 meters at least).

### 1.4 Machine Operation



**CAUTION!** Read thoroughly the operator's manual before operating the sharpener.



**DANGER!** Make sure all guards and covers are in place and secured before operating the sharpener. Failure to do so may result in serious injury.

**DANGER!** Keep all persons away from moving parts when operating this machine (2 meters at least). Failing to do so will result in serious injury.

**DANGER!** Always keep hands away from moving bandsaw blade. Failure to do so will result in serious injury.



**WARNING!** Always wear eye, ear, respiration, and foot protection when operating this machine. Failure to do so may result in serious injury.

**WARNING!** Secure all loose clothing and jewelry before operating this machine. Failure to do so may result in serious injury or death.

**WARNING!** The sharpener should not be operated by persons allergic to ACP-1 oil or its vapors.



**CAUTION!** The sharpener's work-stand should be equipped with a 4 kg or bigger dry powder extinguisher.

**CAUTION!** The machine has to be used only for sharpening blades. Otherwise the guarantee will expire.

**CAUTION!** The machine has to be used only with oil vapour extractor.

# 1 Safety & General Information

## Sharpener Components



**IMPORTANT!** The illumination at the operator's position should be at least 300lx<sup>1</sup>.

### 1.5 Sharpener Components

The BMS250 sharpener is designed for sharpening only Wood-Mizer blades with 9.29, 10.30, 13.29, 7.34, 7.39 and 4.32 profiles.

See **Figure 1-1**. The major components of the sharpener are shown below.

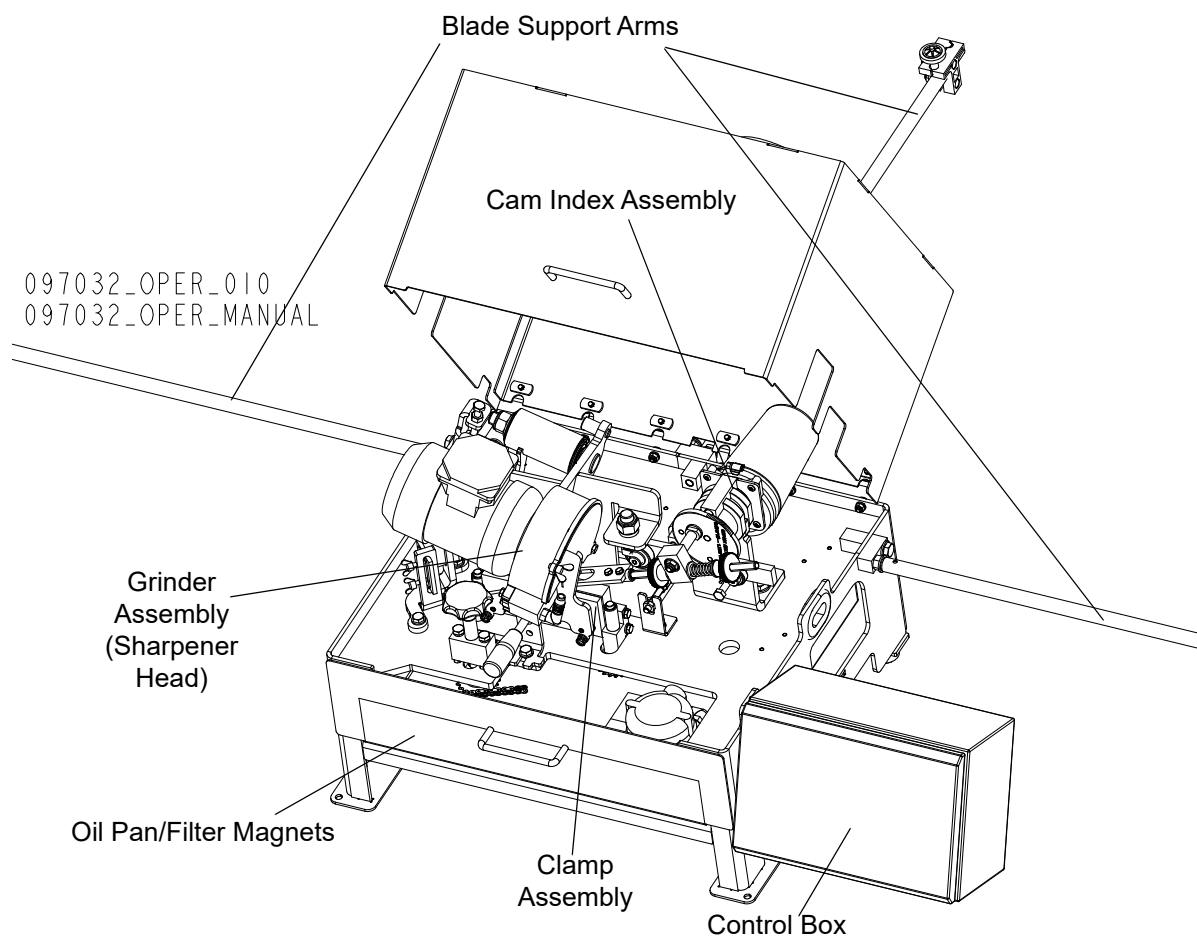

**FIG. 1-1**

1. The light source can not cause stroboscopic effect.

## 1.6 Overall Dimensions and Other Technical Data

See Table 1-2. The overall dimensions and the weight of the BMS250 sharpener (without the blade support arms) are listed below.

	Length	Width	Height	Weight
<b>BMS250 Sharpener</b>	627mm 24,68"	845mm 33,26"	590mm 23,22"	83kg 183 lb
<b>Sharpener packaged in carton</b>	680mm 26,77"	960mm 37,80"	620mm 24,40"	90kg 198,4 lb

**TABLE 1-2**

See Figure 1-2. The figure below shows the overall dimensions of the BMS250 sharpener with the blade support arms installed.

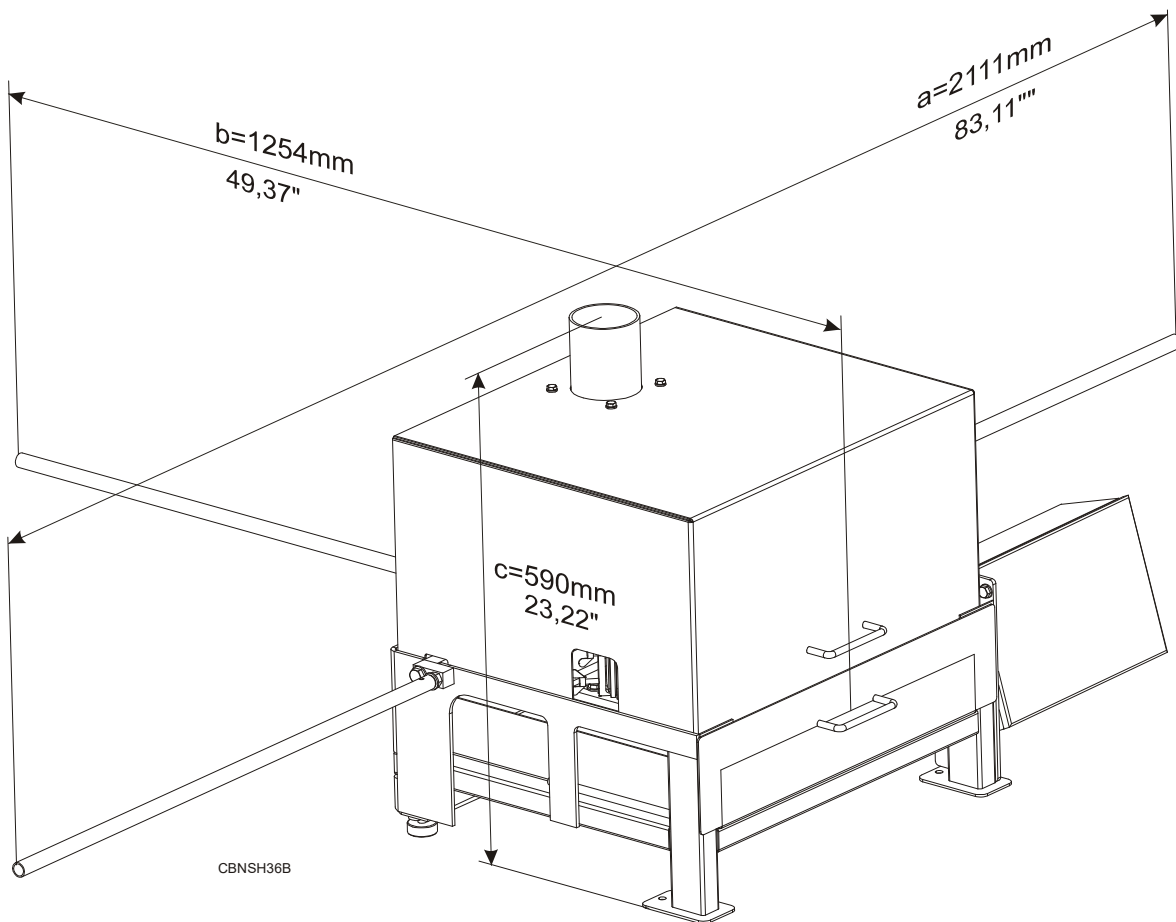

**FIG. 1-2**

# 1 Safety & General Information

## Noise Level

### 1.7 Noise Level

See Table 1-3. The noise level produced by the BMS250 sharpener is given below <sup>1</sup>.

	Noise Level
BMS250	61,3 dB (A)

TABLE 1-3

### 1.8 Motor Specifications

See Table 1-4. The grinder motor specifications are listed below.

Motor	Manufacturer	Model	Power	Other Data
Electric	Besel, Poland	SEKg 56 2C2	0.18kW	1.5 A, 2800 r.p.m.

TABLE 1-4

### 1.9 Coolant Specifications

See Table 1-5. The table below lists the coolant specifications.

Oil Type	Manufacturer	Freezing Point	Flash Point	Autoignition Point
ACP-1E <sup>1</sup>	Orlen	-20° C -4 F	Above 140° C 284 F	250° C 482F

TABLE 1-5

<sup>1</sup> Waste oil must be disposed of in compliance with applicable state and local regulations.

1. The measured values refer to emission levels, not necessarily to noise levels in the workplace. Although there is a relation between emission levels and exposure levels, it is not possible to determine with certainty if preventives are needed or are not needed. The factors affecting a current level of noise exposure during work are inter alia room characteristics and characteristics of other noise sources, e.g. number of machines and machining operations nearby. Also, the permissible exposure level value may vary depending on country. This information enables the machine's user to better identify hazards and a risk .

## 1.10 Control Panel Components

See Figure 1-3. The BMS250 control panel components and their descriptions are shown below.

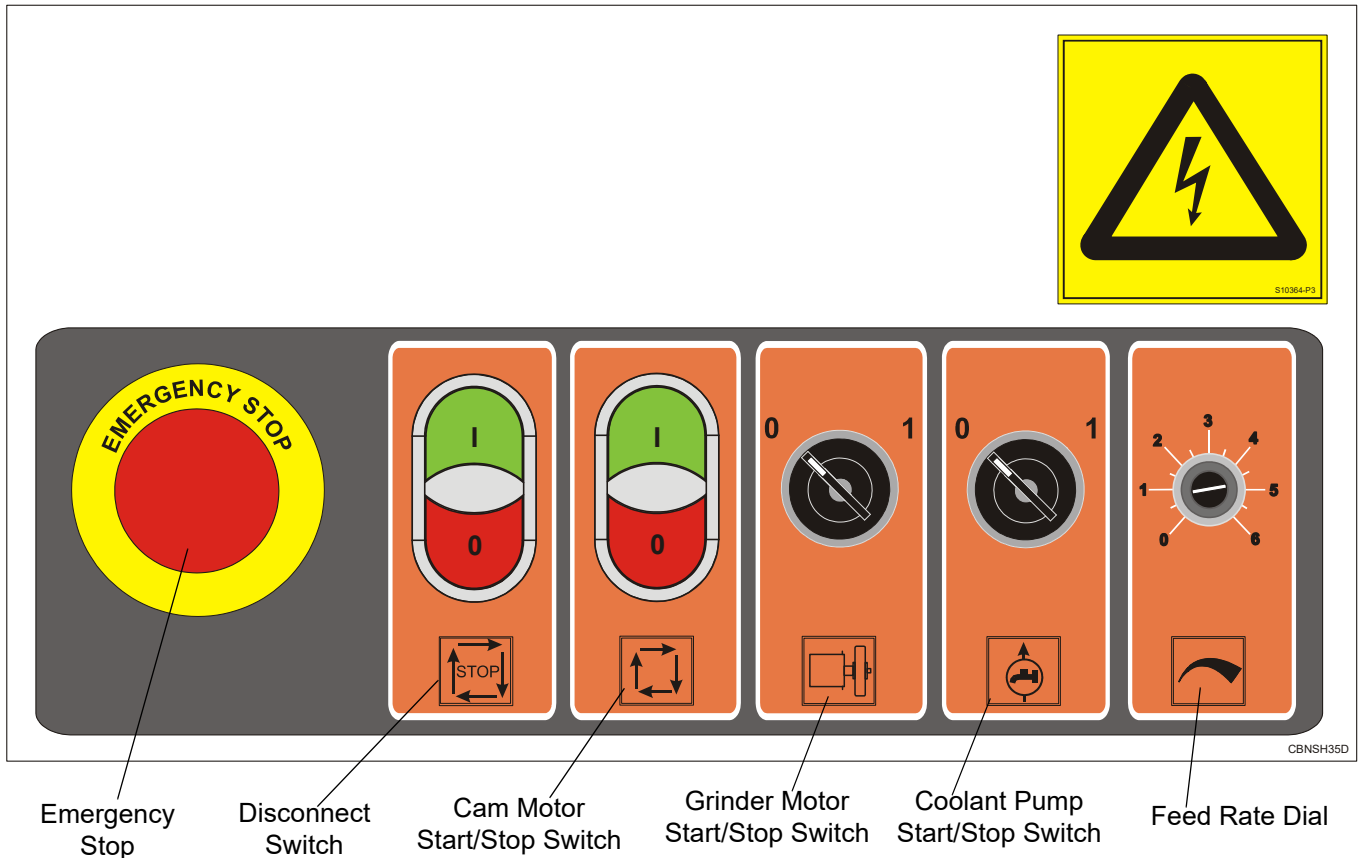

FIG. 1-3

- **Disconnect button**  
**Turns on/off the sharpener power and the oil pump.**

Press "0" on the disconnect switch to turn the sharpener power off (e.g. before servicing or when the sharpener is not in use). NOTE: Press "0" on the disconnect switch before opening the control box door. Disconnect and lock out power supply before servicing!

To reconnect power to equipment, press "1" on the disconnect switch.

- **Feed Rate Dial**  
**Controls cam speed.**

Rotate dial as necessary to increase or decrease cam speed.

- **Grinder Motor Start/Stop Switch**  
Starts/Stops grinder motor.

- **Cam Motor Start/Stop Button**

Press the Cam Motor Start Switch to start the cam motor. **NOTE:** Place the Feed Rate Dial in the "0" position before starting the cam motor.

Press the Cam Motor Stop Switch to turn the cam motor off and unclamp the blade.

- **Coolant Pump Start/Stop Switch**

Starts/Stops coolant pump.

- **Emergency Stop**

Stops the sharpener operation.

In case of any dangerous situation or any incorrectness in the sharpener operation, press the emergency stop button. The button will be locked.

To release the emergency stop button, turn it clockwise.



See **Figure 1-4**. The control panel components of the **BMS200** version and their descriptions are shown below.

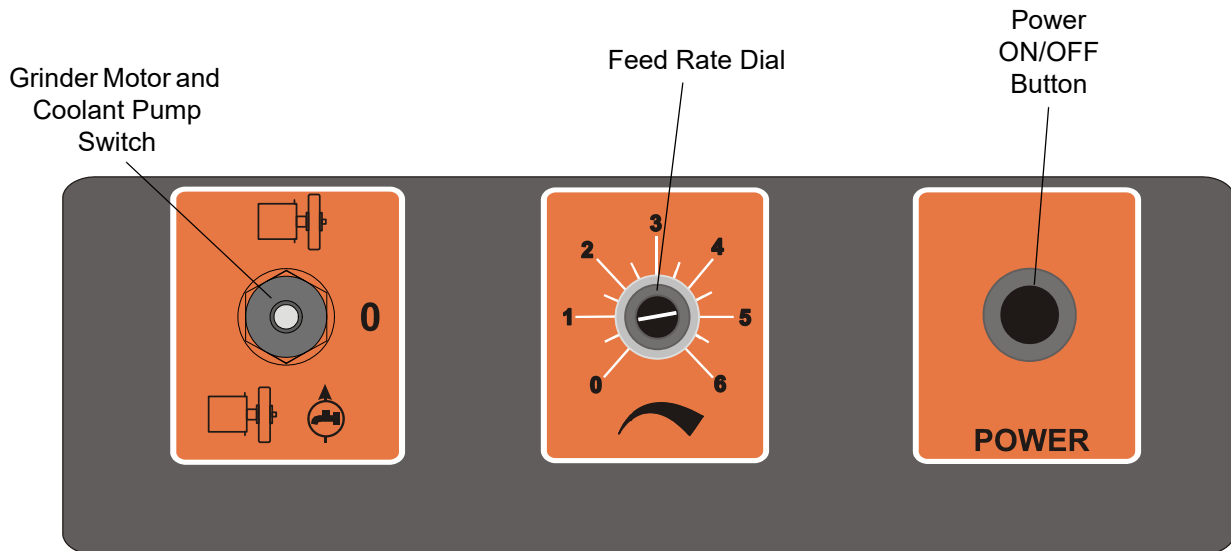

**FIG. 1-4**

- **Grinder Motor and Coolant Pump Start/Stop Switch**

Starts/Stops grinder motor and coolant pump. Move the switch to upper position to start the grinder motor only (it can be used to adjust the sharpener). Move the switch to lower position to start the grinder motor and the coolant pump.

- **Feed Rate Dial**  
**Controls cam speed.**

Rotate dial as necessary to increase or decrease cam speed. Turn the dial to "0" position to stop the cam.

- **Power ON/OFF Button**

Turns on the power to all motors of the sharpener. **NOTE:** Place the Feed Rate Dial in the "0" position before turning on the power.

# 1 Safety & General Information

## Warning Decals Description

### 1.11 Warning Decals Description

See Table 1-6. The pictographic decals that warn and inform the user are shown and described below.

**TABLE 1-6**





Decal View	Decal No.	Description
	S10364-P3	"Hazardous voltage".
	086362	General warning symbol
	099220	CAUTION! Close all guards and covers before starting the machine.

TABLE 1-6

	<p>095961</p>	<p>"Use ACP-1 oil."</p>
	<p>S12004G-1</p>	<p>CAUTION! Always wear safety goggles when operating the sharpener!</p>
	<p>S20097C</p>	<p>2800 RPM - Motor rotation direction</p>
	<p>P85070</p>	<p>CE safety certification</p>

# 1 Safety & General Information

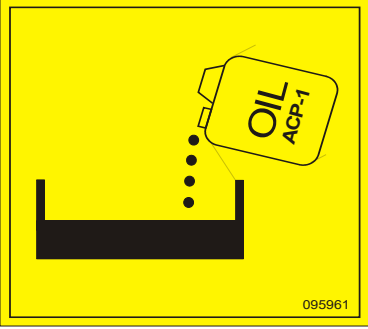
## Warning Decals Description

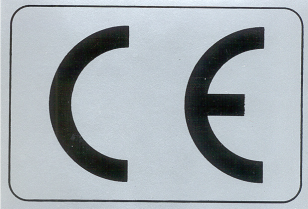
TABLE 1-6

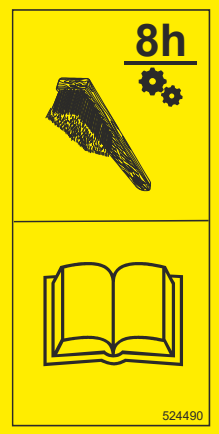
	524490	Clean the sharpener every 8 hours of operation.
-----------------------------------------------------------------------------------	--------	-------------------------------------------------

## SECTION 2 SETUP & OPERATION

### 2.1 Machine Start



**IMPORTANT!** Before starting to use the machine you have to meet the following conditions:

- Fasten the sharpener to a table top using the mounting holes located in the foot plates.
- The sharpener can be operated with a oil vapors exhaust system only.
- The machine can be operated under roof only.
- The sharpener can be operated only in temperature range from 5° C to 40° C (41 - 104° F), at the humidity of up to 80%.
- The oil for cooling the grinding wheel must meet the specifications listed in Table 1-5 on page 6. Water or other liquids must not be used.
- The position of the sharpener's operator is shown below.
- The illumination at the operator's position should be at least 300lx<sup>1</sup>.

---

1. The light source can not cause stroboscopic effect.

# 2

## SETUP & OPERATION

### *Blade Support and Cover Bumper Installation*

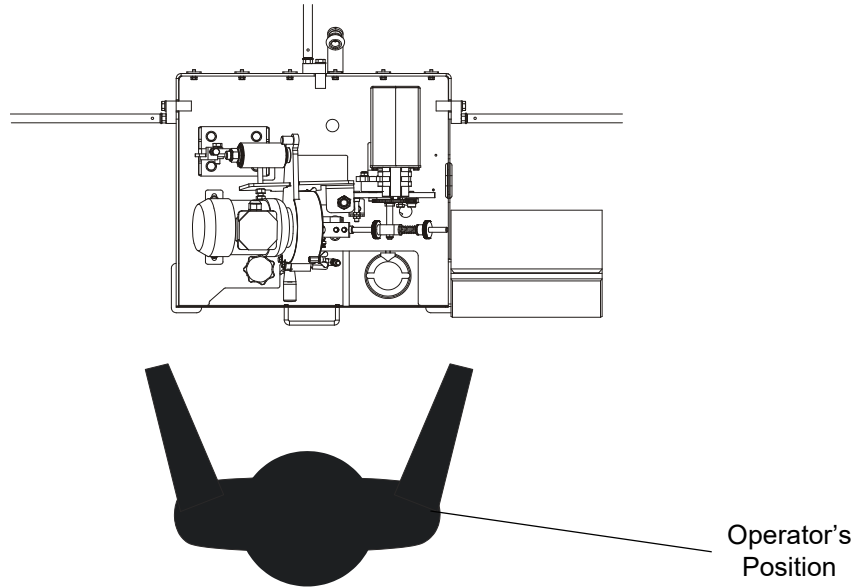

- Have a qualified electrician make the power supply. The power supply must meet the specifications given below.

2-Phase Volts	Fuse [A]	Suggested Wire Size
230 VAC	10 A	1.5 mm <sup>2</sup> at least 16AWG at least

**TABLE 2-0**

**DANGER!** It is recommended that a 30mA Ground Fault Interrupter (GFI) be used.

## 2.2 Blade Support and Cover Bumper Installation

The sharpener includes three blade support arms with guide assemblies.

To install the support arms, lubricate the threaded ends of the arms with grease. Insert one arm into the threaded holes on each side of the sharpener.

1. Each guide assembly consists of a blade support with post, a blade support without post, two bolts, a self-locking nut, and a wing nut.

**See Figure 2-1.** To install the guides, join one guide assembly around the end of each blade support arm. Face the post outward as shown. Bolt from the hexed side of the guide assembly (these hex-shaped holes will keep the bolts from turning once in place). Secure the bottom bolt with a self-locking nut. Secure the top bolt with a wing nut.

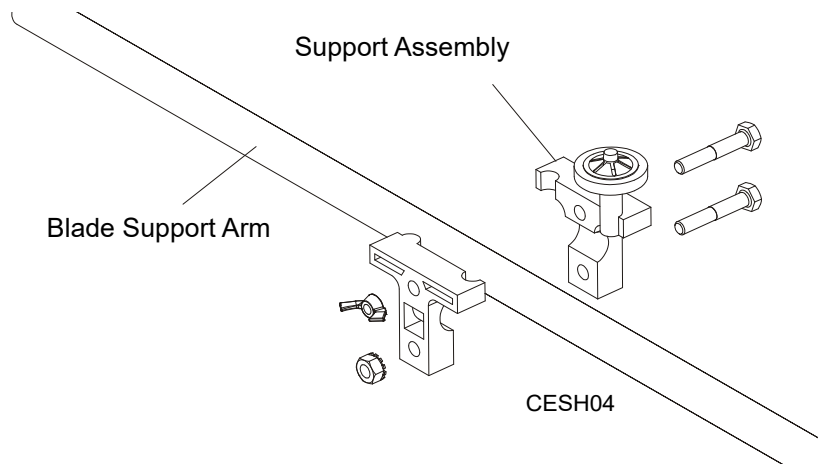

2. Tilt the guides on the left blade support arm slightly backward, toward the rear of the sharpener. Tilt the guides on the right support arm slightly forward, toward the front of the sharpener.
3. Install the bumper of the sharpener cover. Use provided M10x25 bolt and 10.5 flat washer.

## **2** **SETUP & OPERATION** *Blade Support and Cover Bumper Installation*

---

See Figure 2-2.

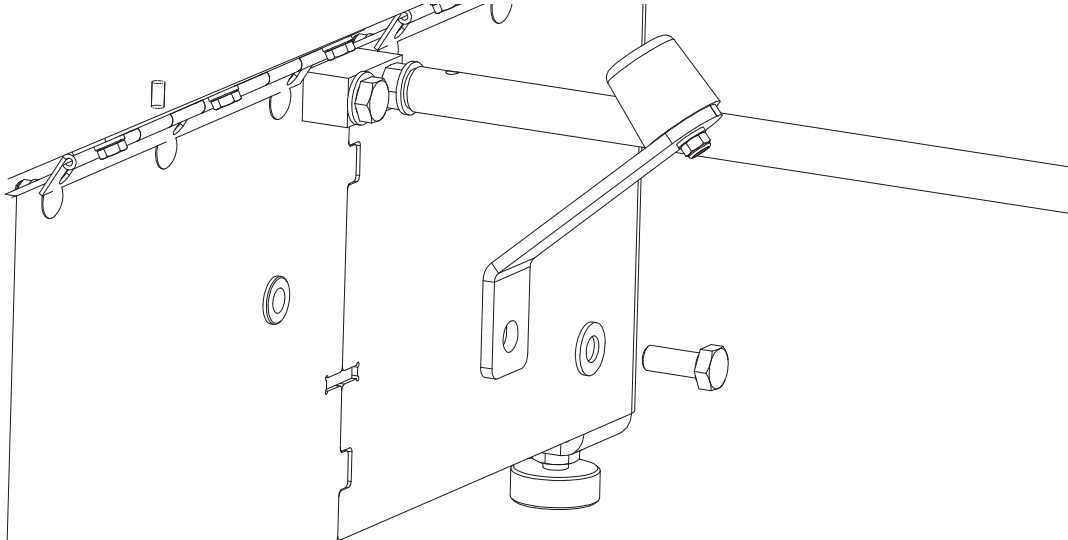

**FIG. 2-2**



## 2.3 Blade Height Adjustment

The BMS250 sharpener is equipped with a blade height adjustment assembly that allows smooth height adjustment of 1", 1 1/4", 1 1/2", 1 3/4" and 2" wide blades.

To install the blade, release the blade clamp by pushing the clamp handle down.

**See Figure 2-3.** Position the blade on the cylindrical rollers of the blade height adjustment screws as shown below. Use the blade height adjustment knob to adjust the blade height.

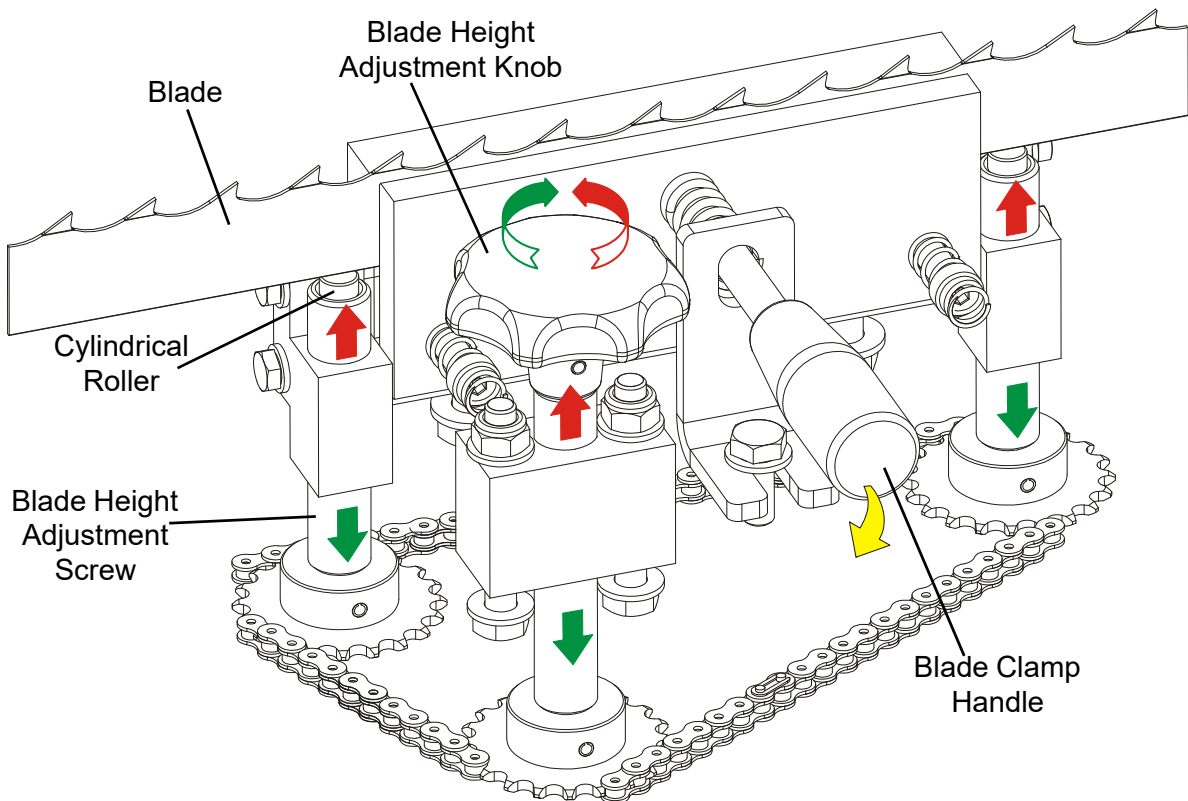

FIG. 2-3

**NOTE:** After adjusting the blade height, adjust the blade support arms in the vertical plane as necessary so the blade will remain level around its complete length.

#### 2.4 Grinding Wheel Installation

Use a Wood-Mizer approved grinding wheel. To install:

1. Push the START button on the control box and turn the FEED RATE dial up to rotate the cam.
2. Rotate the cam until the sharpener head is at its highest setting. Turn the FEED RATE all the way down and push the STOP button.
3. Remove the grinding wheel cover.
4. Remove the oiler.
5. Remove the arbor nut.
6. Slide a grinding wheel onto the motor shaft. dedicated to work
7. Reinstall the arbor nut and hand tighten. Reinstall the grinding wheel cover and suitable oiler dedicated to work with your grinding wheel. [See Section 8.3](#)



**DANGER!** Make sure all guards and covers are in place and secured before operating the sharpener. Failure to do so may result in serious injury.

8. If the installed grinding wheel is running out axially, unscrew the arbor nut, turn the grinding wheel about 15 degrees and replace the arbor nut. Then check the grinding wheel's rotation. If the axial runout is still present, perform the above-mentioned steps again. Repeat them as necessary until the problem is corrected.
9. After installing and adjusting the grinding wheel, hold the sharpener head up with your hand and turn the back/depth grind knob until you can lower the head and the grinding wheel will not contact the blade. Carefully lower the sharpener head.
10. Place the provided pump plate and two filter magnets in the oil pan as shown to collect sediment. Orient the magnets around the pump in the front right corner of the oil pan.

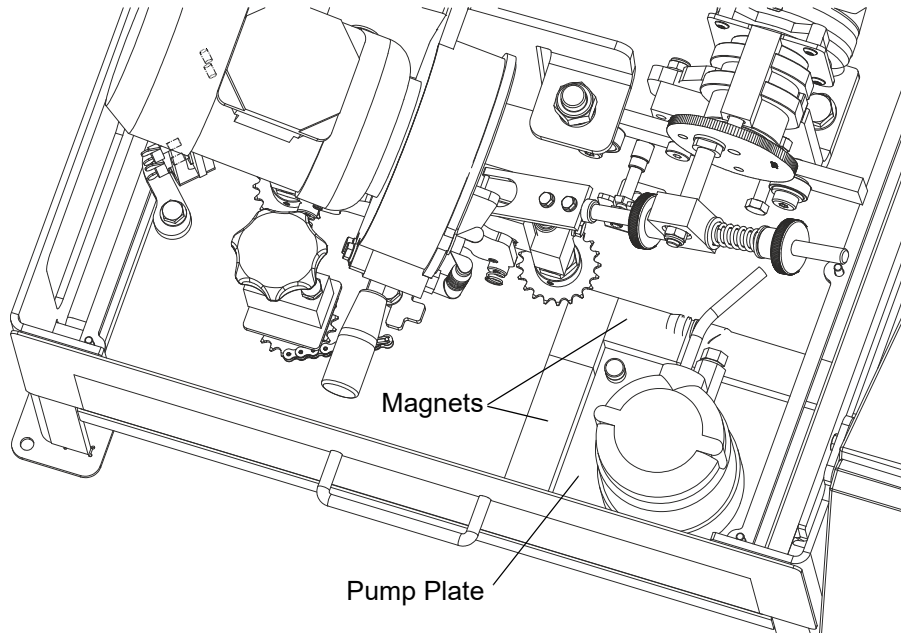

## 2 SETUP & OPERATION

### *Blade Installation*

#### 2.5 Blade Installation

See Figure 2-4. Before installing a blade, push the cam motor START switch and turn the FEED RATE dial until the cam pivot bolt is at the 2 o'clock position.

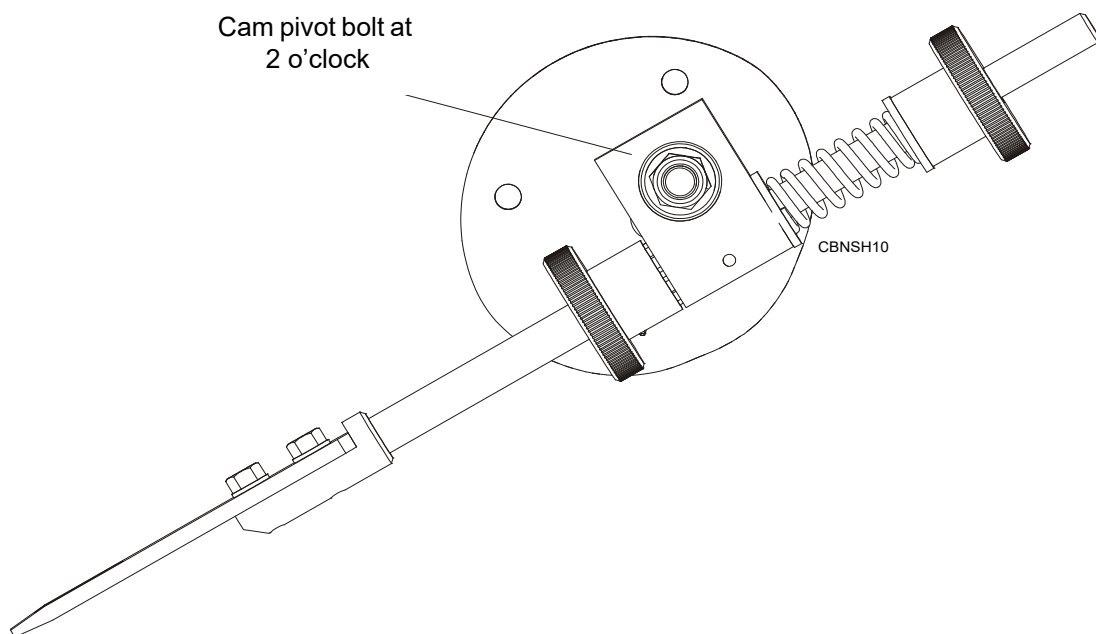

**FIG. 2-4**

Uncoil a blade and position above the three support assemblies around the sharpener. Check to be sure the teeth on the portion of blade that will be under the grinding wheel point to the right as you face the sharpener. If not, remove the blade and invert it.

**See Figure 2-5.** Position the blade inside the left and rear blade support posts.

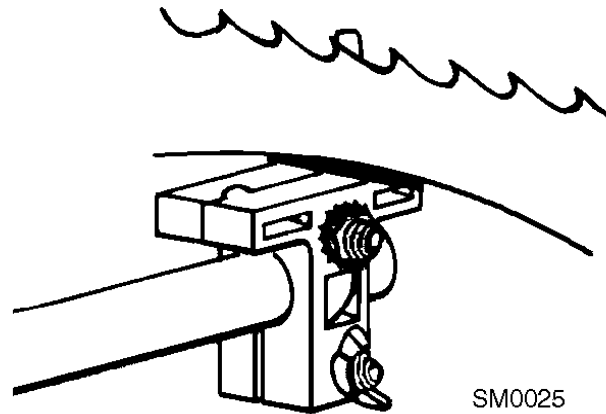

**FIG. 2-5**

**See Figure 2-6.** Position the blade outside the right blade guide wheel.

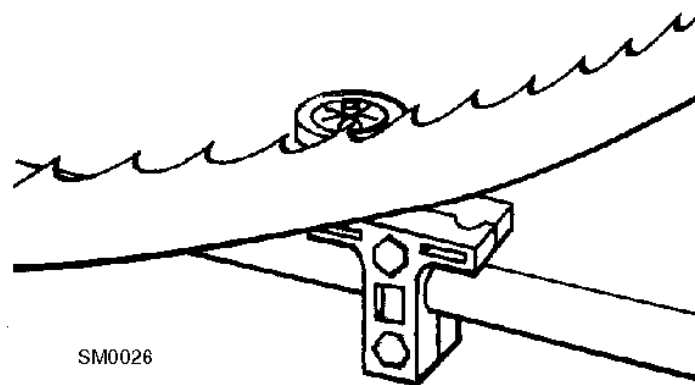

**FIG. 2-6**

Holding the blade with your left hand, lift the sharpener head. Then raise and hold the indexing arm up, loosen the blade clamping fixture and press the blade between the clamping plates. Lower the indexing arm and the sharpener head.

Make final adjustments to the blade support arms and guide assemblies. Make sure the blade band rests evenly on both blade rest cylindrical rollers. The blade should not touch the bottom of either side guide assembly. All three guide assemblies should lean slightly in the direction the blade travels through them.

Bend the blade wiper on the left side of the sharpener so that it touches the blade. The wiper will wipe coolant from the blade into the oil pan so it does not drip on the floor.

## 2.6 Face Grind Adjustment

As you operate the sharpener, the cam will rotate causing the index arm to contact a tooth and push it to a position under the grinding wheel. The index arm can be adjusted to leave the tooth closer to or further from the grinding wheel so the tooth face is ground lighter or heavier.

1. Before adjusting the face grind, make sure the cam and grinder motors are off, the feed rate dial is set at "0" and the Sharpener head is raised.
2. Install the blade.
3. Lower the Sharpener head and check to make sure the grinding wheel lightly contacts the entire face of the tooth all the way up to the tip.
4. Turn on the cam motor and slowly increase the FEED RATE until the next tooth is underneath the grinding wheel.

**See Figure 2-7.** If the face grind is too light, turn the face grind adjustment knob out away from the other knob. If the face grind is too heavy, turn the adjustment knob in toward the other knob.

5. Recheck the face grind on the next tooth and adjust as needed.

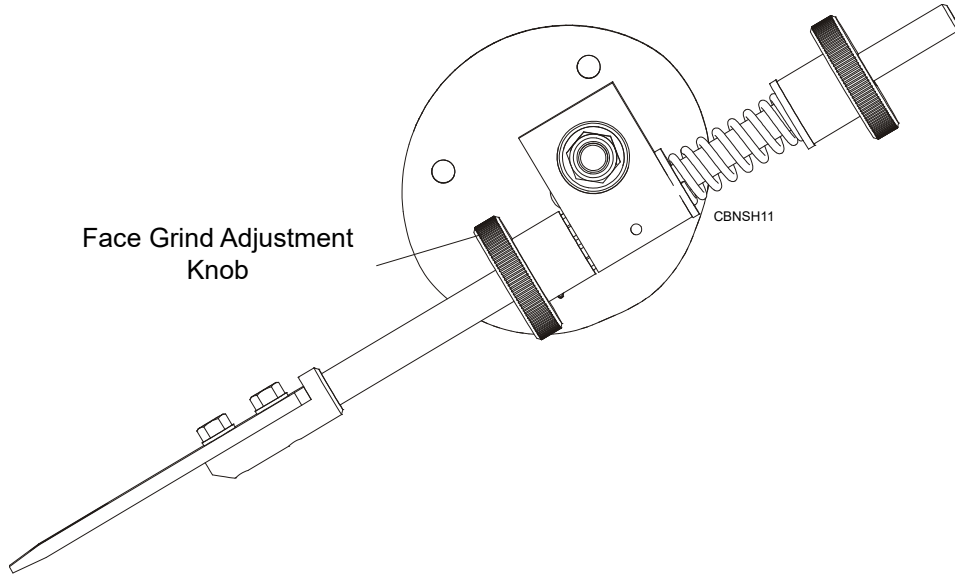
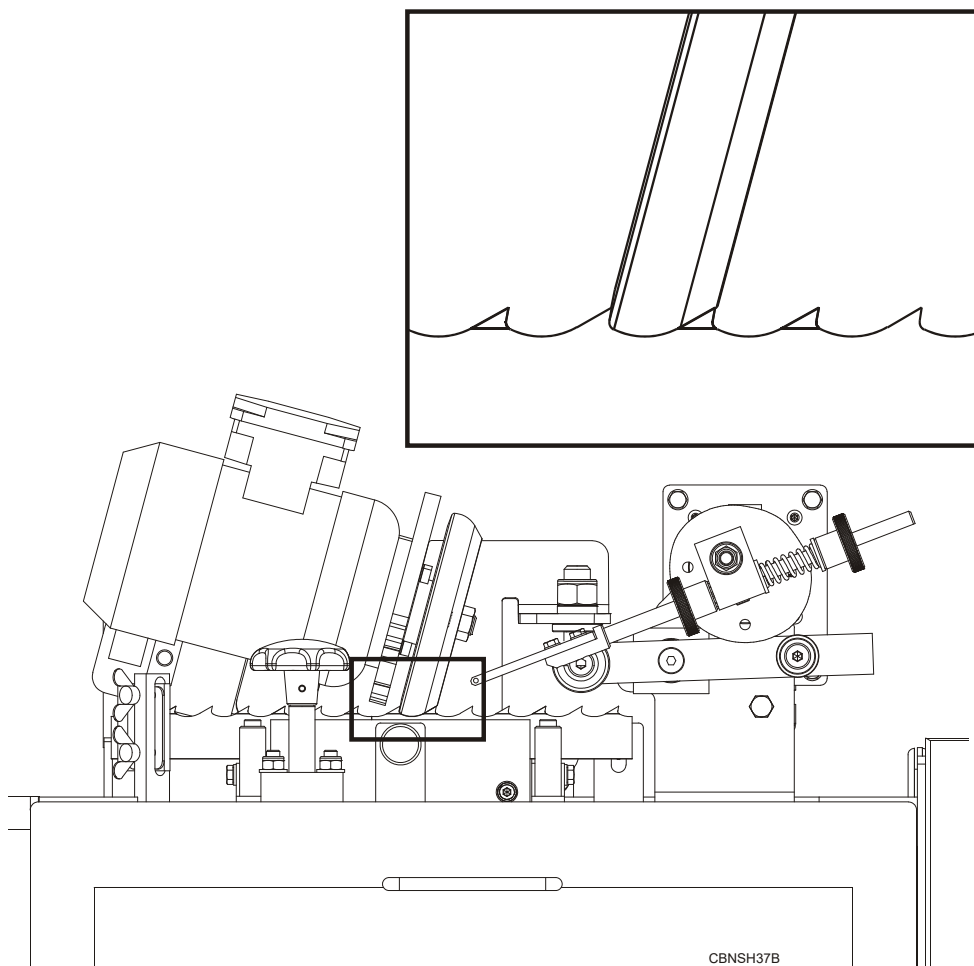

**FIG. 2-7**

## 2 SETUP & OPERATION

### *Face Grind Adjustment*

See **Figure 2-8**. Proper position of the grinding wheel to blade during sharpening is shown on the picture below.



**FIG. 2-8**



## 2.7 Grind Depth Adjustment

Tooth height is determined by how much material is removed from the gullet of the blade. The Wood-Mizer sharpener is equipped with a grind depth adjustment bolt that controls how far the grinding head comes down and therefore controls the gullet grind. (See Figure 2-10.)



**CAUTION!** The grind depth adjustment bolt is factory-set and should not need to be readjusted. The gullet grind should be adjusted by setting the blade height with the blade height adjustment knob. ([See Section 2.3.](#))

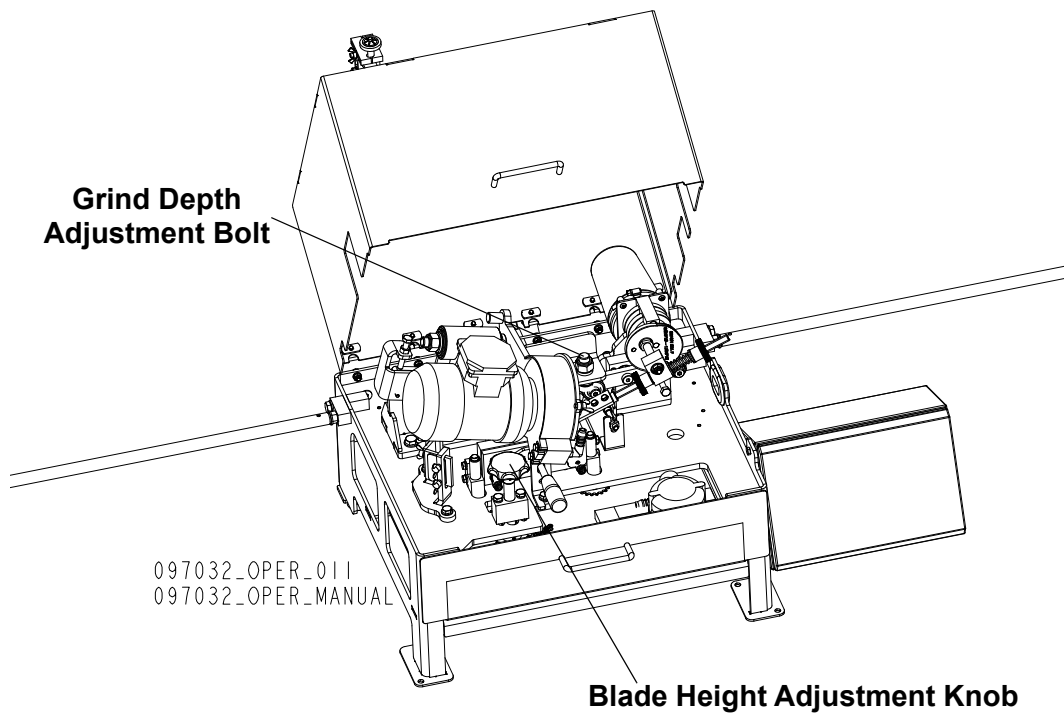

FIG. 2-8

**NOTE:** Depth grind may be affected as the grinding wheel passes over blade welds.

## 2.8 Feed Rate Adjustment

The Feed Rate Dial controls cam speed. During the sharpening cycle, adjust cam speed to have as fast of a feed rate as possible without "burning" the blade.

## 2.9 Magnetic Shut-off (not in BMS200, BMS250 EC Version)

See **Figure 2-9**. The shut-off sensor is located to the right of the blade clamp assembly. When passed over by a magnet, it automatically shuts down the grinder and cam motors.

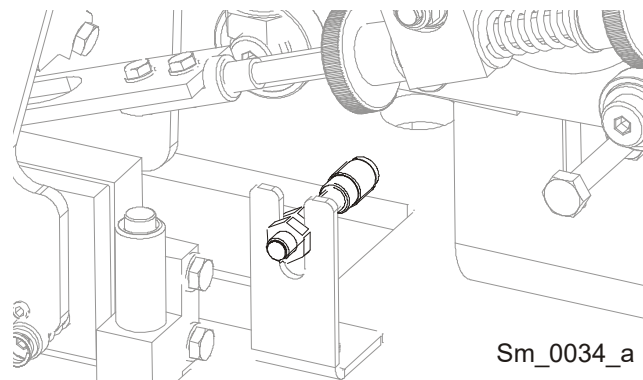

**FIG. 2-9**

To install, take an orange-painted magnet from the bag assembly. Place the black side of the magnet against the bottom edge of the blade on the inside of the tenth face-ground tooth. After the sensor bracket has shut off the cam and grinder motors, flip the grinder switch into the off position. Remove the magnet.

## 2.10 Blade Rejection

Sometimes blades cannot be resharpened. Reasons to reject blades for resharpening include:

- the blade is coil set (the blade is over-stressed and will fold on itself),
- the blade is missing 2 or 3 teeth or more in a row,
- the blade band has been twisted,
- the blade band is too low for the grinder (the blade has been sharpened too many times/too much material has already been ground from the blade),
- the blade has no set on one of its sides,

- severe rust is present,
- or the blade has tooth spacing uncommon to Wood-Mizer blades (i.e., a competitor's blade).

## 2.11 Operation Overview

Use the following steps to guide you through sharpener operation.

1. Adjust the blade clamp for the blade you will be sharpening.
2. Install a grinding wheel if necessary, then install the blade.
3. Adjust face grind and depth grind.
4. Activate the oil flow.
5. During the initial blade sharpening setup, check the depth grind two to three times. Adjust as necessary.
6. Increase the feed rate to a moderate speed. How fast you can grind will be determined by how much material you are removing from the blade. If a heavy grind is required, it is best to go around the blade lightly twice rather than try to grind heavily once.
7. After about ten teeth have been ground, mount the orange-painted magnet right behind the blade wiper. (See Section 2.11.) If you use the BMS200, BMS250 EC, mark the start of sharpening with a sticker or marker.  
**IMPORTANT!** After any adjustment, always restart the blade and sharpen in its entirety to ensure symmetry.

## 2.12 Shutoff

The sharpener will automatically shutoff when blade has been entirely sharpened (not in BMS200, BMS250 EC Version)

Inspect the blade. Repeat sharpening process if necessary. Blades with a bad profile or those which are badly in need of sharpening may have to be ground more than once.

## **2** SETUP & OPERATION

### *2" Blade Sharpening*

#### **2.13 2" Blade Sharpening**

To sharpen 2" blades, it is necessary to mount the bushing supplied with the BMS200/250 sharpener.

**See Figure 2-10.** Mount the bushing to the sharpener head bracket as shown below.

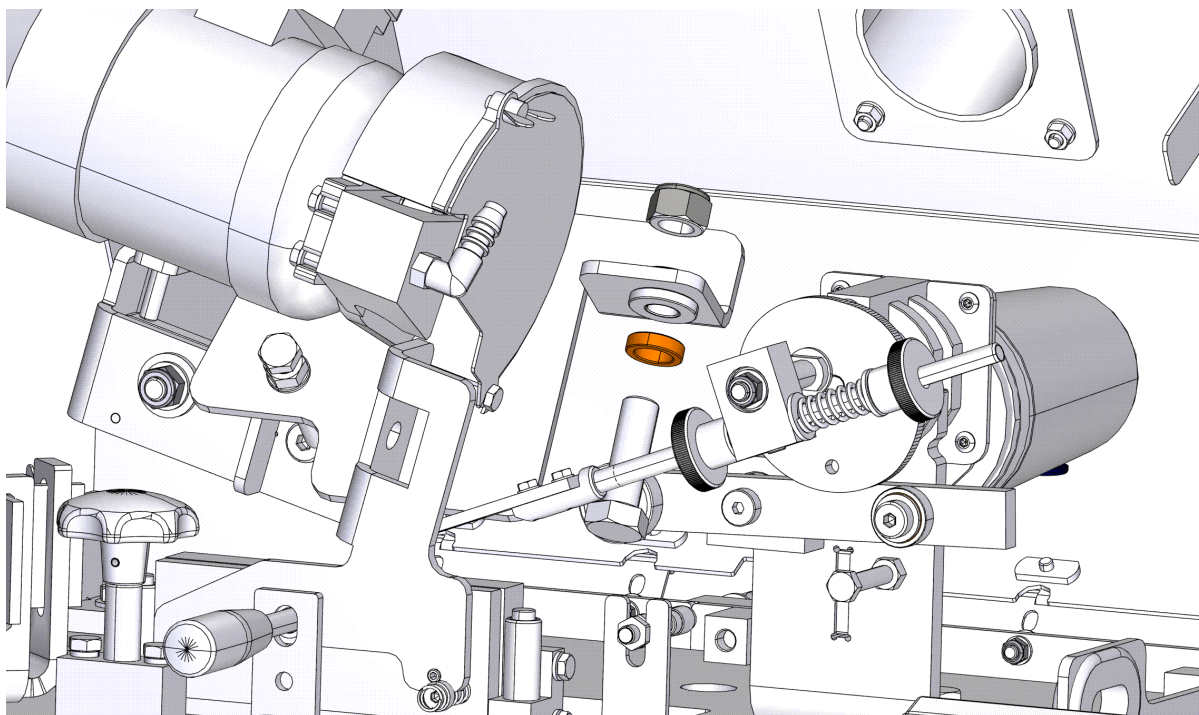

**FIG. 2-10**

---

## SECTION 3 MAINTENANCE

### 3.1 Grinding Wheel Replacement

Check the grinding wheel often and change as necessary. Wheels approved for use with the sharpener are available from Wood-Mizer.

The grinding wheel should be in good condition. Replace if worn, the edges look shiny, and/or the wheel is "burning" the blades. **NOTE:** The grinding wheels have a CBN (Cubic Boron Nitride) coating.

1. To replace, shut down and lock out all power to the machine.
2. Remove the grinding wheel cover.
3. Remove the grinding wheel nut, washer plate and grinding wheel.
4. Install the new grinding wheel. Reinstall the washer plate and nut.
5. Reinstall the grinding wheel cover.

### 3.2 Oil Level

Periodically check the oil level and refill with oil as necessary. The oil level should be kept between 4.5 and 5 litres. Use only Wood-Mizer approved grinding oil.

Filter the oil to remove metal shavings before reusing.

## SECTION 4 PREPARING THE SHARPENER FOR SHARPENING VORTEX BLADES



**DANGER!** Before replacing any sharpener component, disconnect the power cord.



**IMPORTANT!** To increase the Vortex blade life, the time intervals between sharpenings should not be longer than one hour.

### 4.1 Grinding Wheel and Oiler Replacement

1. Unbolt the mounting hardware (A and B) and dismount the grinding wheel covers (C and D).

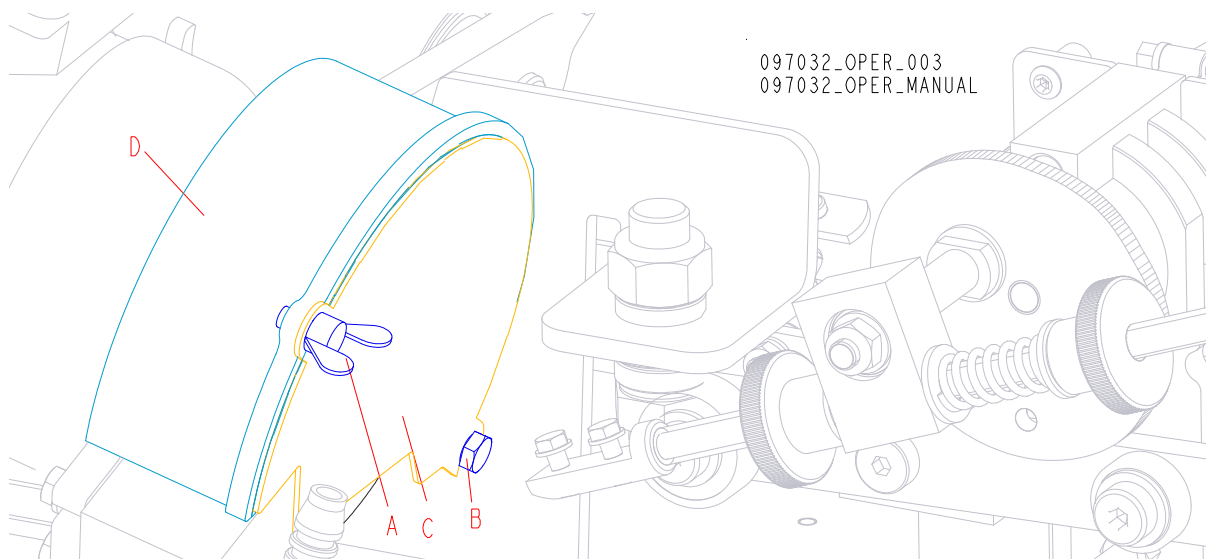

FIG. 4-1

2. Unbolt the mounting hardware (A) and remove the oiler (B).

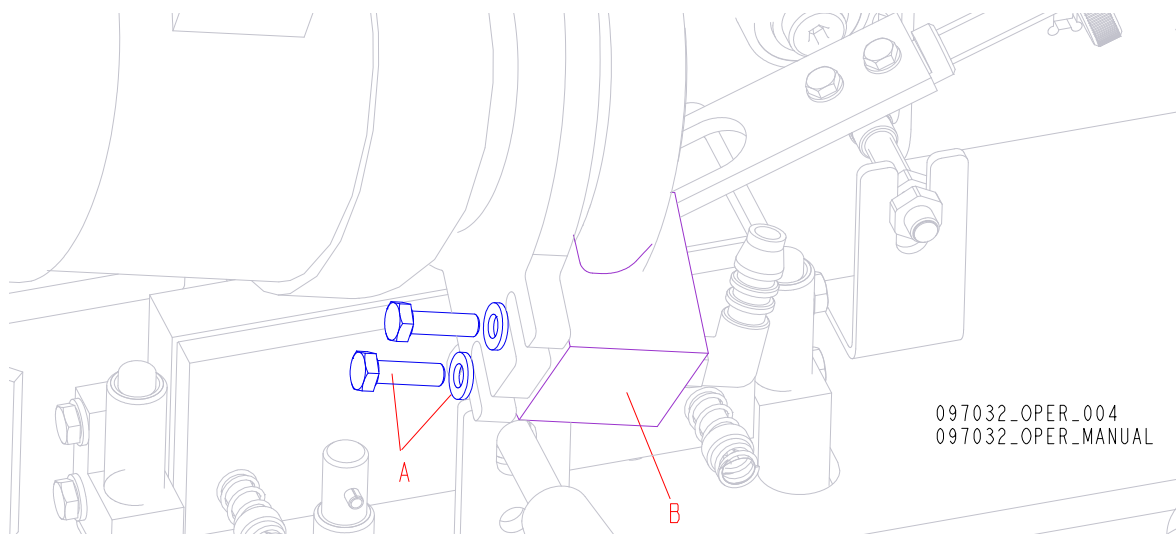

FIG. 4-2

3. Remove the nut (A) and dismount the grinding wheel (B). Then install the grinding wheel No. 077698.

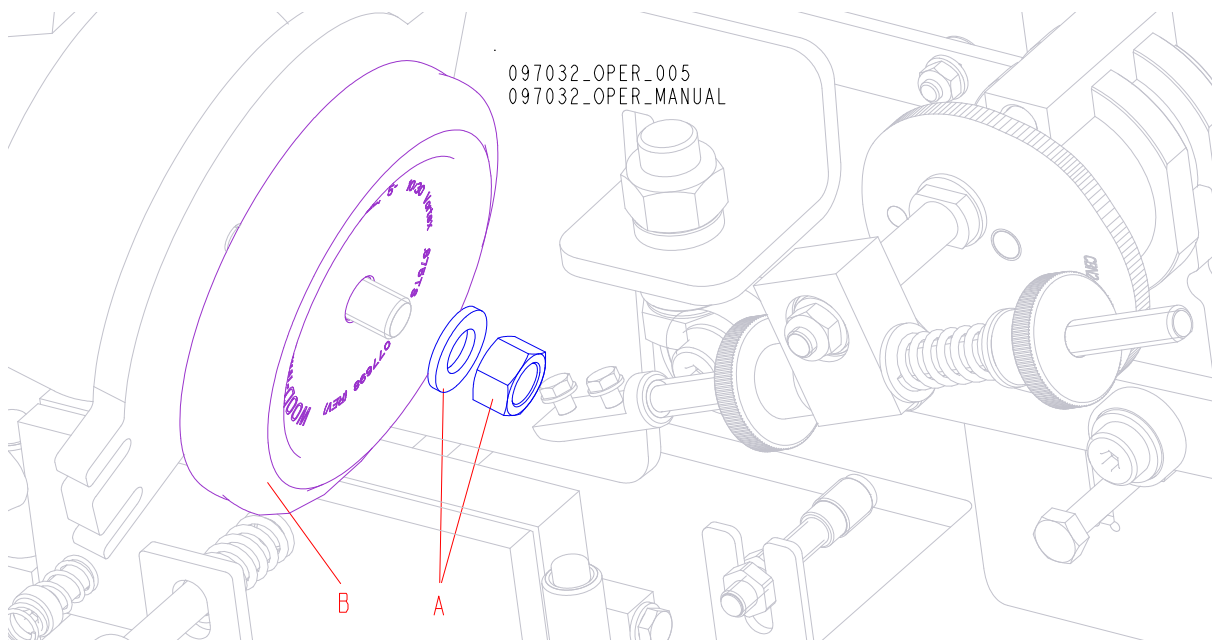

FIG. 4-3

4. Install the oiler No. 522706 (B) using the hex head bolts and washers (A).

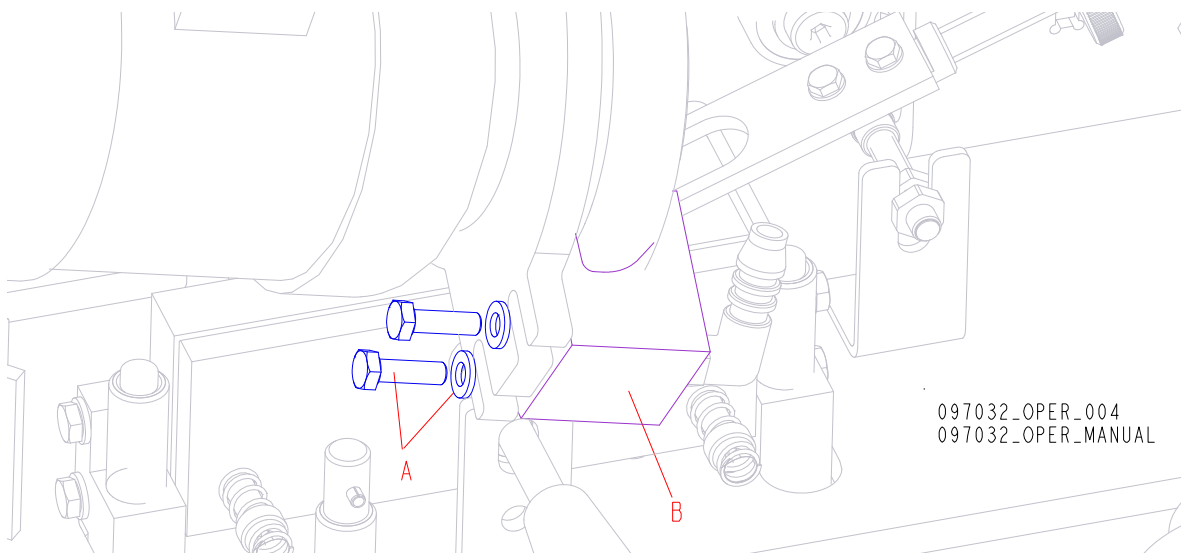

FIG. 4-4

# 4

## Preparing the sharpener for sharpening VORTEX blades

### Cam Replacement

5. Mount the grinding wheel covers (C, D) using the mounting hardware (A and B).

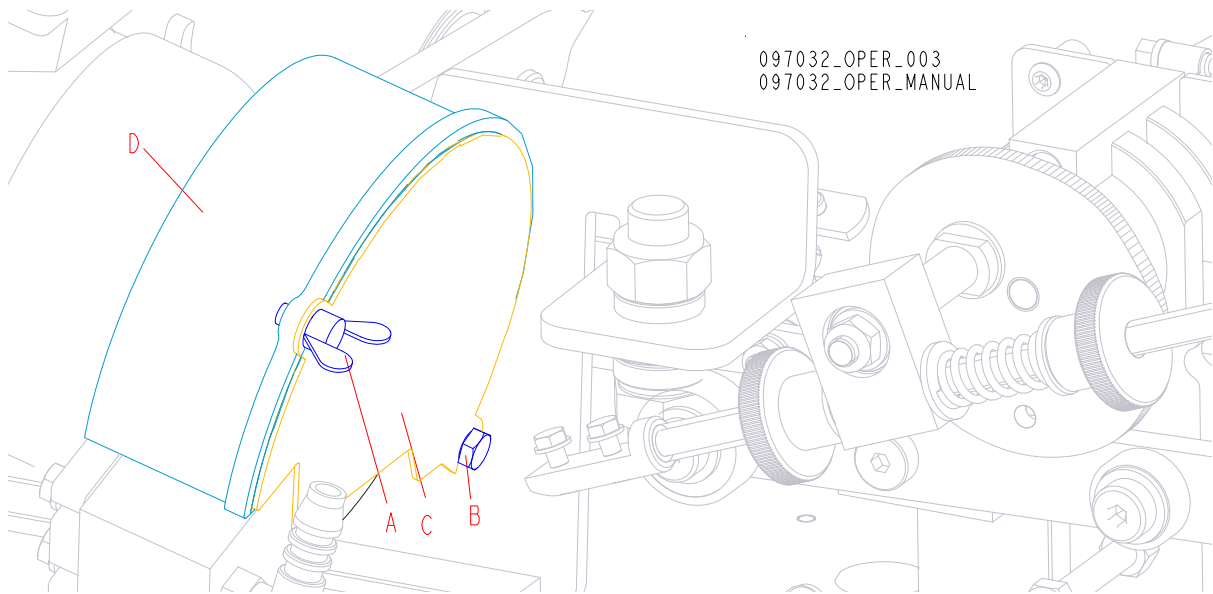

FIG. 4-5

## 4.2 Cam Replacement

1. Dismount the pusher (B) by removing the pusher shaft (A) from the cam.

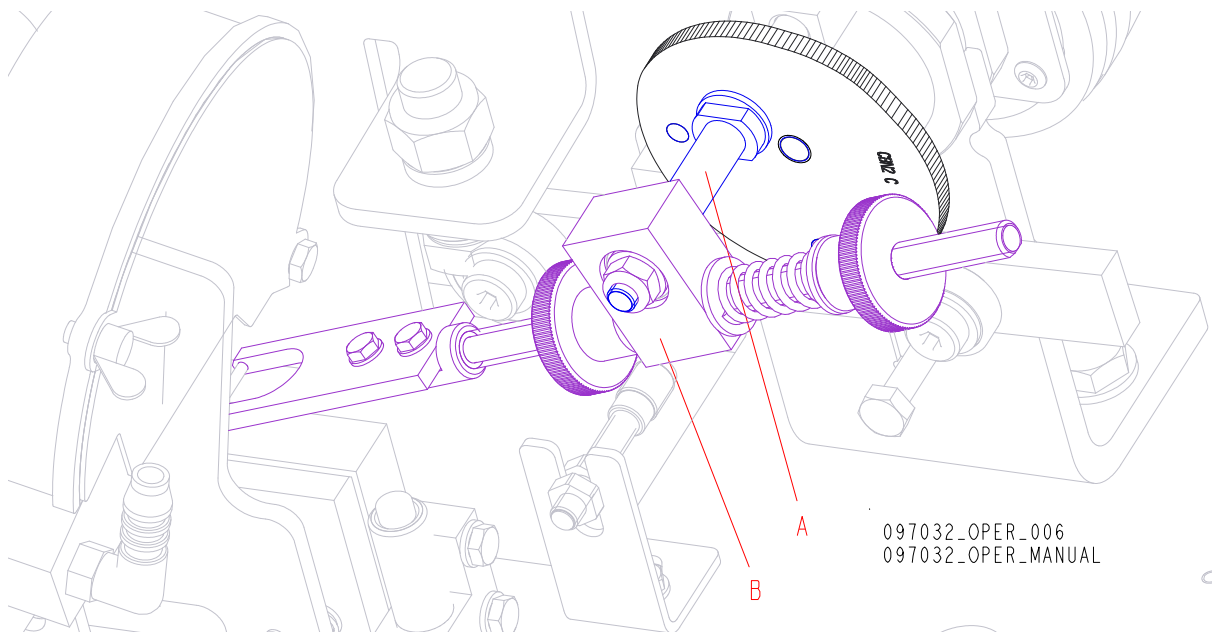
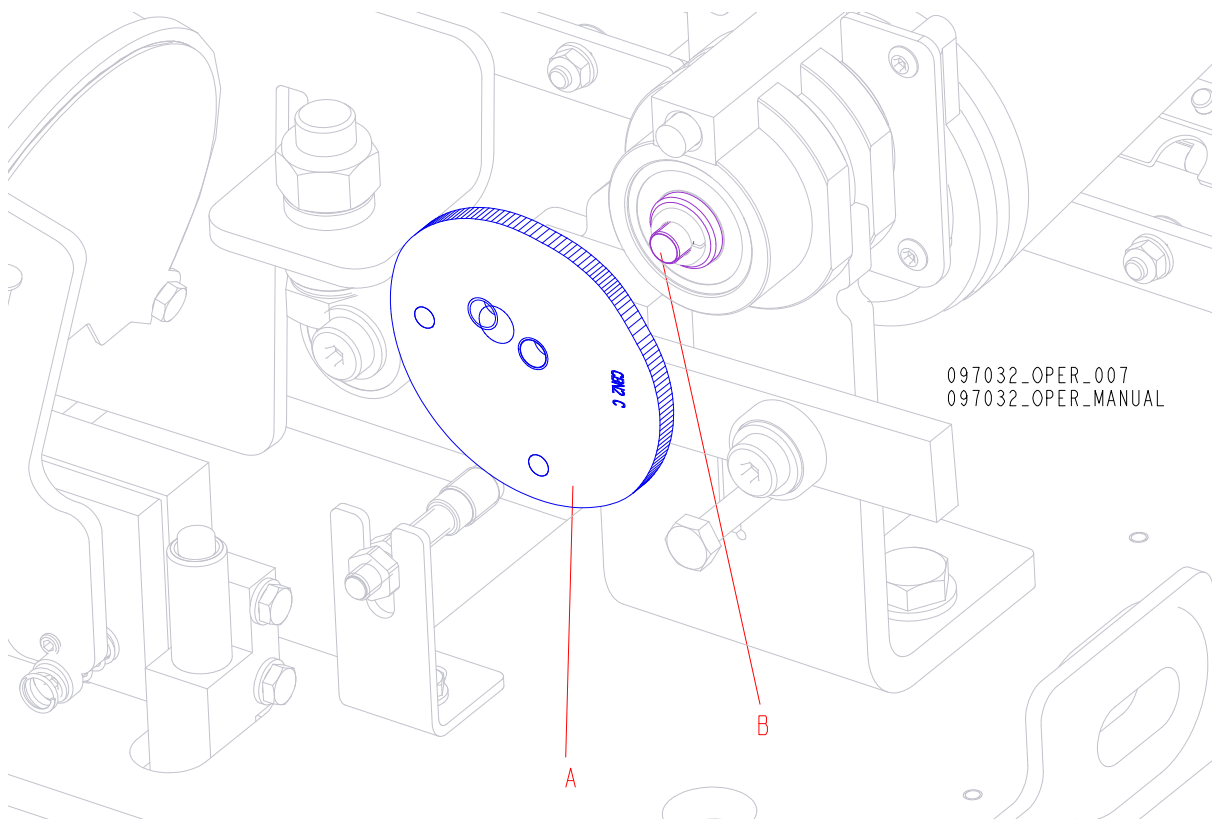

FIG. 4-6



- Remove the cam (A) from the shaft (B). Then install the cam No. 057401 marked "Rev. E" so that the marked side of the cam is pointing toward the operator side of the sharpener.



**FIG. 4-7**

- Mount the blade pusher (B). To do this, fasten the pusher shaft (A) to the cam.

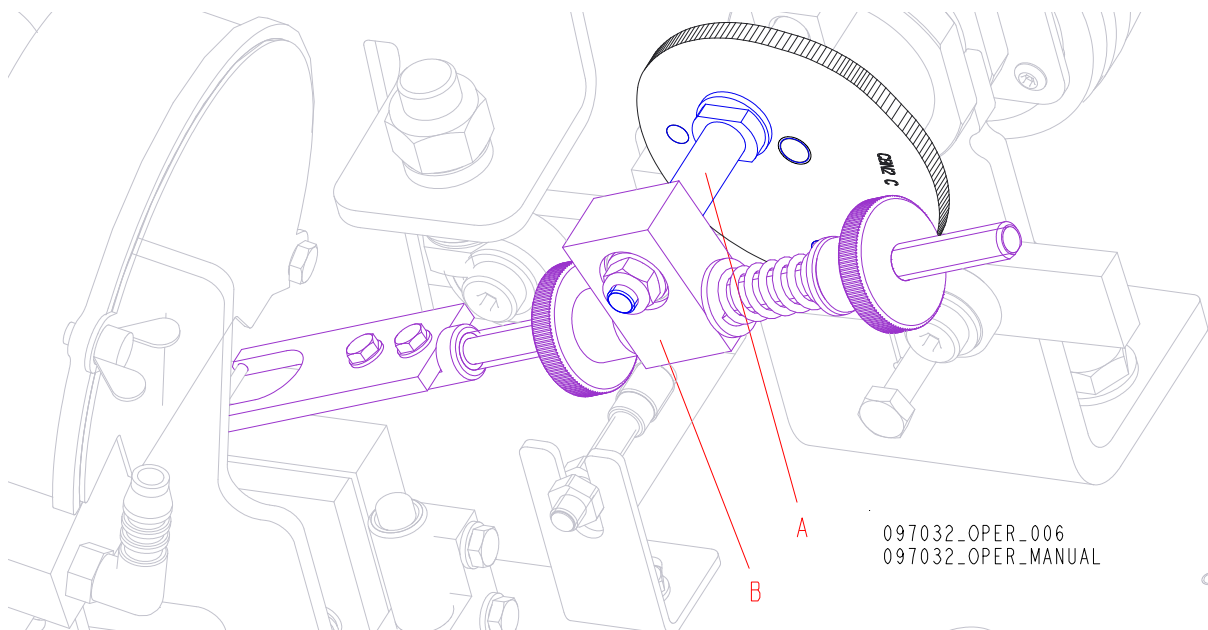

**FIG. 4-8**

### 4.3 Blade Pusher Adjustment

Using the adjustment nuts (A), adjust the blade pusher (B) so that it pushes the next tooth after the tooth to be sharpened.

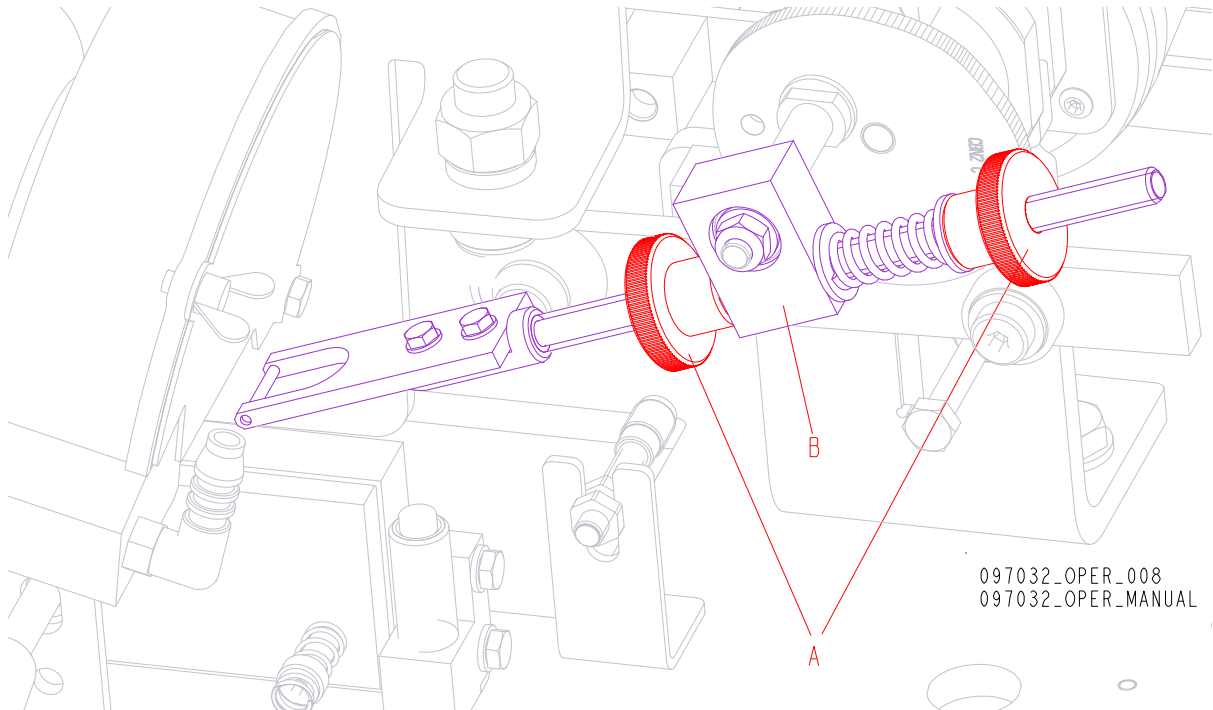

FIG. 4-9

### 4.4 Sharpener Head Adjustment

Use the bolt shown below (A) to raise the sharpener head (B) by 3 to 4 mm.

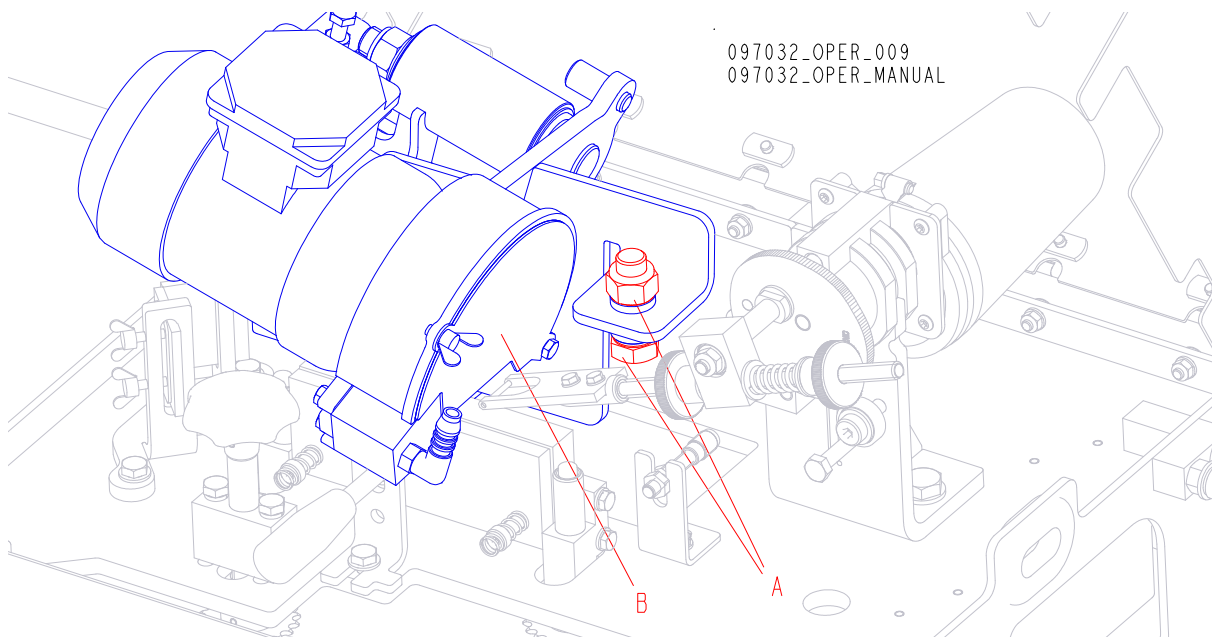

FIG. 4-10

## SECTION 5 BMS200/BMS250 MAINTENANCE & TROUBLESHOOTING

### 5.1 Sharpener Maintenance



**DANGER!** Swarf (metal filings) must be cleaned and removed from the oil pan and filter magnets every 8 hours of operation to avoid possible fire. Failure to do so may result in death or serious injury.

*Daily (after end of the shift):*

- Clean sediment from the oil pan and filter magnets.
- Wipe the sharpener dry, remove the blade, lower the head, close the cover and unplug the machine after each day's use.
- Keep clean of dirt, rust, and metal filings.
- Remove the clamp regularly and clean out any buildup that might cause it to not clamp the blade firmly. To do so, unscrew the blade rest bolts and remove the moving clamp plate.

*Weekly:*

- Keep the oil at such a level that the pump strainer is completely covered with the oil. Replace the oil completely every six months. Oil level should be 40-50mm measured from the bottom of reservoir. Dispose of worn-out oil in compliance with applicable regulations.
- Check sharpener head stop function. [See Section 6.1.](#)

*Monthly:*

- Check motor and indexer brushes.
- Check plugs and switches.
- Check the axial run-out and the radial run-out on the motor shaft at the place where the grinding wheel is mounted. Do it once a month, using a dial indicator mounted on a magnetic stand. The maximum allowable run-out must be no greater than  $\pm .01$  mm, 0,00039".
-



**CAUTION!** Regularly clean or replace oil vapors extractor filter (according to manufacturer's recommendation).

## 5.2 Blade Sharpening Tips

This section covers some of the common problem areas of blade sharpening.

Before removing from the saw, clean the blade by running the waterlube on the blade for 15 seconds. This will remove most of the sap buildup that would otherwise have to be scraped off when it dries. Wipe with a clean dry rag.

Make sure the flow of oil through the oiler assembly is strong.

Sharpen the blade when it first shows signs of dullness. If the blade is extremely dull, due to hitting a rock or some form of foreign matter, sharpen the blade twice lightly, instead of trying to remove too much in one grind. Grinding too much material at once may cause the circuit breaker in the control box to kick out. If this happens, wait 15 seconds. Then turn it on (push circuit breaker down).

## SECTION 6 ALIGNMENT

Align the sharpener monthly to ensure quality performance. Also realign the sharpener as necessary (i.e., after the grinding wheel has been impacted by the index pawl).

### 6.1 Sharpener Head Stop Alignment

Adjust the distance between blade clamp and grinding wheel using the locking bolt, to avoid hitting the blade clamp with the sharpener head (when there is no blade in the clamp).

Distance between grinding wheel and blade clamp should be 2.0-3.0mm, 0,078-0,11".

Repeat the adjustment monthly.

Sharpener head stop adjustment is shown below.

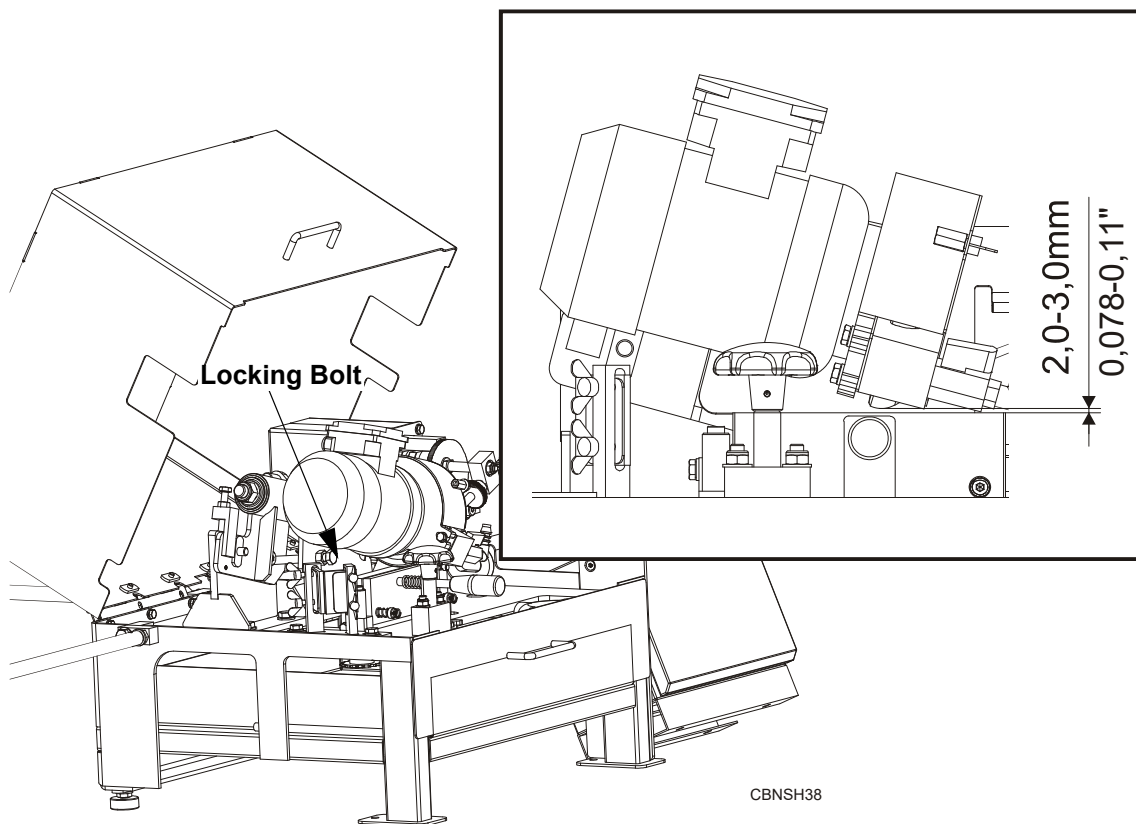

FIG. 6-1

## 6.2 Sharpener Alignment

Use the provided BMS250 sharpener alignment tool as necessary to achieve accurate alignment between the blade clamp and the grinding wheel.

**IMPORTANT!** Do not adjust the alignment tool bolts. They have been pre-calibrated at the factory to ensure accurate alignment results.

1. **IMPORTANT!** Make sure the grinder motor is OFF. Cycle the cam until the grinding wheel is at the tip of the tooth (about to begin face grind).
2. Remove the grinding wheel cover and sharpener arbor nut. Dismount the oiler. Remove the grinding wheel.
3. Remove the blade rest bolts and moving clamp plate.
4. Install the alignment tool to the grinder motor shaft as shown below.

**See Figure 6-2.** Position the tool so all three gauge points are in line with the front clamp plate. Secure the tool in position with the sharpener arbor nut.

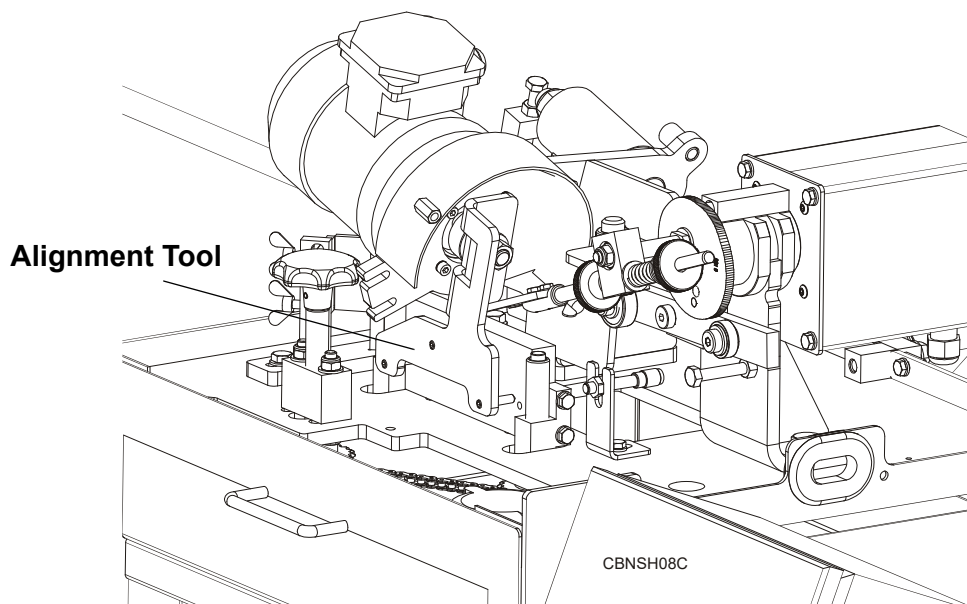

**FIG. 6-2**

5. Loosen the clamp adjustment bolts.

6. Position the clamp assembly so the front clamp plate touches all three tool gauge points. Secure in position by tightening the clamp adjustment bolts.

See Figure 6-3.

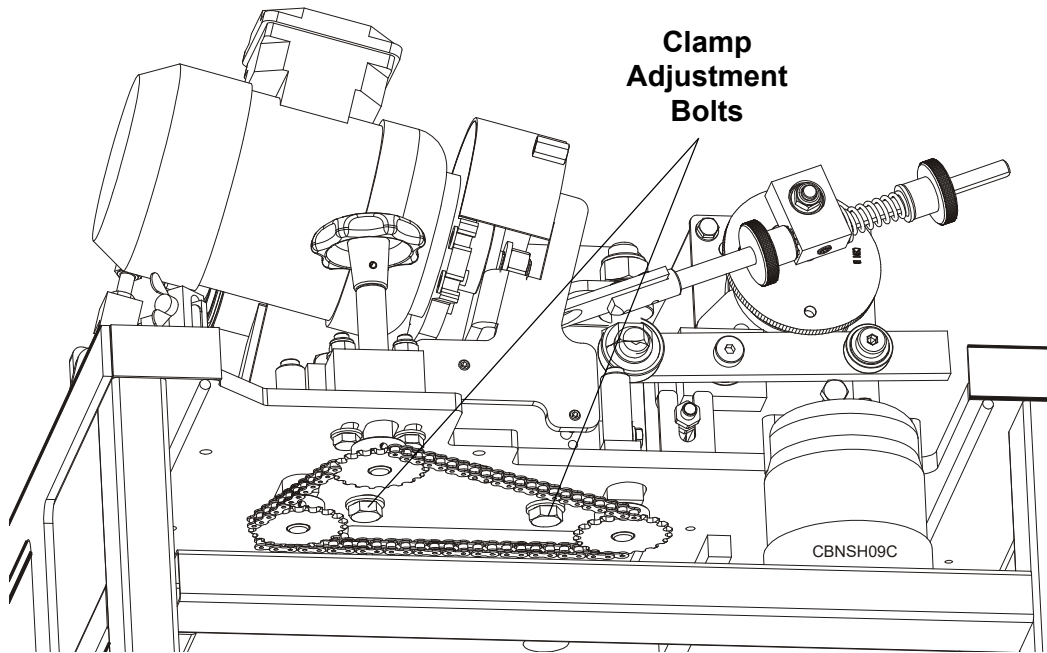

FIG. 6-3

7. Remove the arbor nut and alignment tool.
8. Reinstall the moving clamp plate.
9. Reinstall the grinding wheel and secure in place with the arbor nut.
10. Mount the oiler. Reinstall the grinding wheel cover.

## **SECTION 7 STANDARD OPERATING PROCEDURE**





## 7.1 Sharpening alignment: BMS 250

# Wood-Mizer®

### STANDARD OPERATING PROCEDURE

### SHARPENING ALIGNMENT: BMS 250

The Wood-Mizer CBN wheel grinders are designed to sharpen the saw blades by a full plunge grind. This means the grinding wheel is designed to have the same profile as the blade you are sharpening. A full plunge grind requires the blade to be properly aligned so the wheel lowers fully into the gullet of the blade. Not doing so can ruin the profile of the blade and wear out the CBN wheel too quickly.

1. With the head raised, insert blade into the clamp. Raise or lower the blade so the bottom of the gullet is level with the clamp or slightly above.

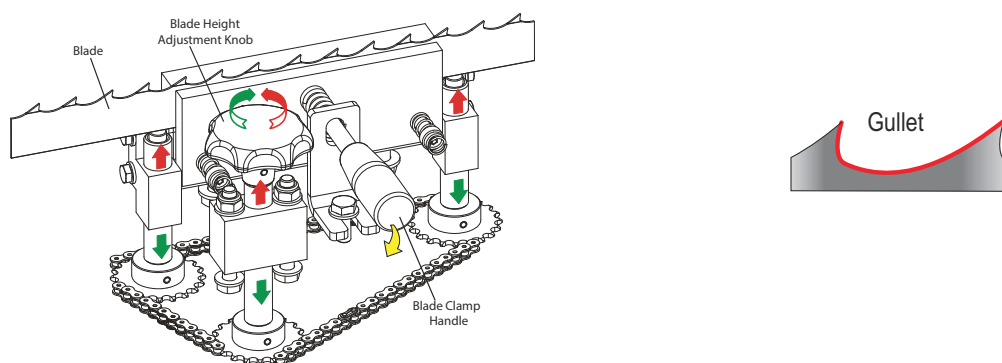

2. With the head still raised, operate the pawl for a couple of strokes to move the blade forward.

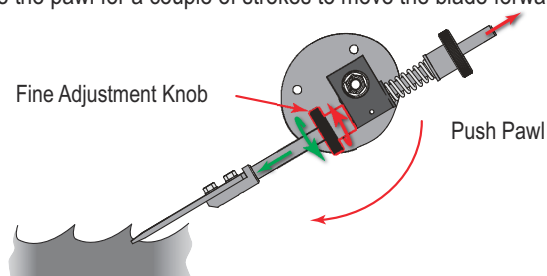

3. Lower the head so the CBN wheel just misses the face of the tooth on the blade. Adjust the pawl to adjust the blade position.

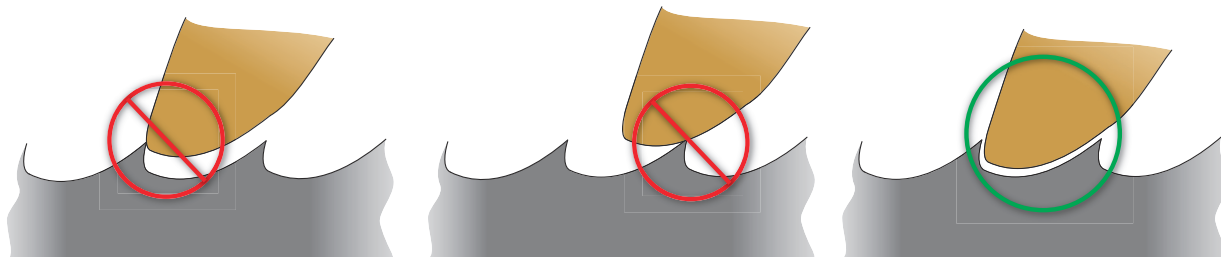

# Wood-Mizer®

## STANDARD OPERATING PROCEDURE

## SHARPENING ALIGNMENT: BMS 250

4. Raise/Lower blade and/or adjust push pawl with fine adjustment knob so there is a small gap between grinding wheel and blade.

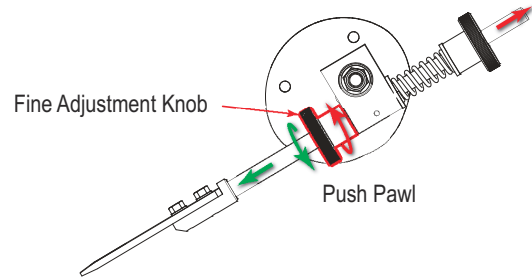
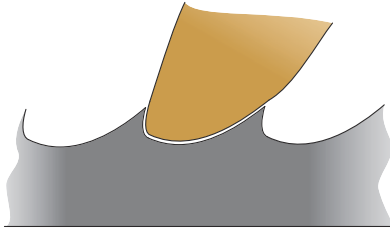

5. When sure that the grinding wheel is not touching the blade and is properly positioned, start the grinding wheel and the feed system slowly and raise blade so the grinding wheel just touches the blade.

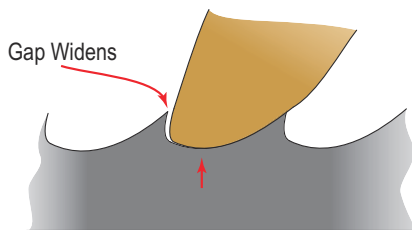

Blade Height Adjustment Knob

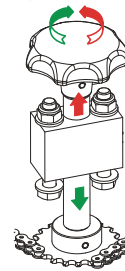

6. Make adjustments using the fine adjustment knob on the push pawl to close the gap between the tooth and the grinding wheel.

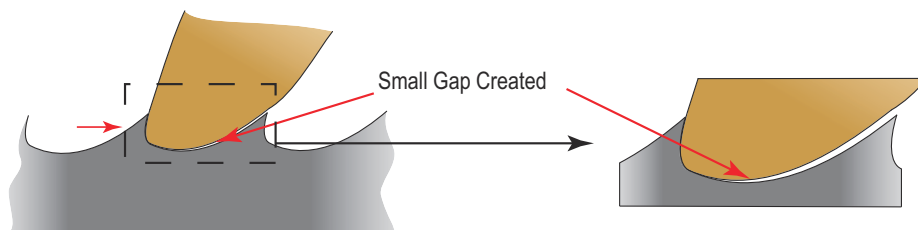

# Wood-Mizer®

## STANDARD OPERATING PROCEDURE

## SHARPENING ALIGNMENT: BMS 250

---

7. Raise the blade again so it touches the grinding wheel. The grinding wheel should have full contact through the gullet of the Blade. If there is still a gap, repeat steps 3 - 5 continuing to adjust the blade until full contact.



### NOTE:

Do not allow the CBN wheel to start grinding the tip before the wheel is fully in the gullet. Grinding the tip of the tooth prematurely will result in ruining the profile of the blade and ruining the CBN Wheel.



CBN wheel damaged by premature grinding of the tooth tip.

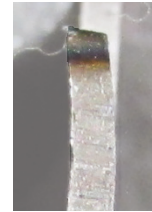

Excessive burning on the tip is a sure sign that the CBN wheel is starting the grind at the tip of the tooth, as opposed to the full "plunge" profile grind.

## 7.2 Properly sharpened teeth

# Wood-Mizer®

### PROPERLY SHARPENED TEETH

**Importance:** It is important to have a properly sharpened blade to allow the blade to cut wood as efficiently as possible. Poorly sharpened blades will result in less efficient cuts, resulting in blade friction that will cause the blade to heat up, lose tension, and result in wavy cuts.

#### Properly Sharpened Blade

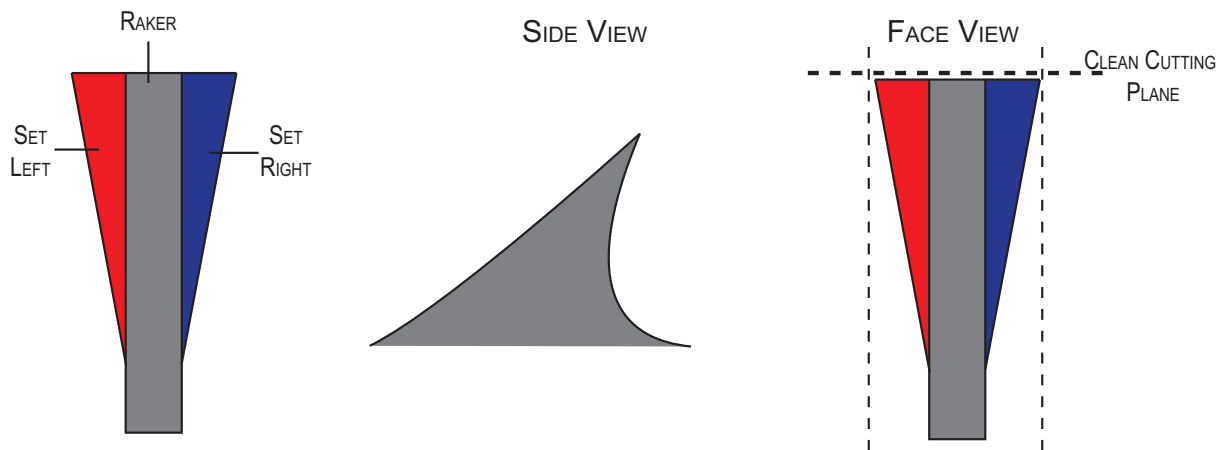

Having sharp clean edges allows the blade to cut straight through the wood and gives the body of the blade enough room to slide through without dragging.

#### Dull Blade

During the cutting process, blades are dulled by cutting the fibers of the wood. The process of dulling the blade is faster in hard or abrasive timbers than it is in easy to cut soft woods.

- Bluntness can be seen visually by light being reflected from the blunt edge.

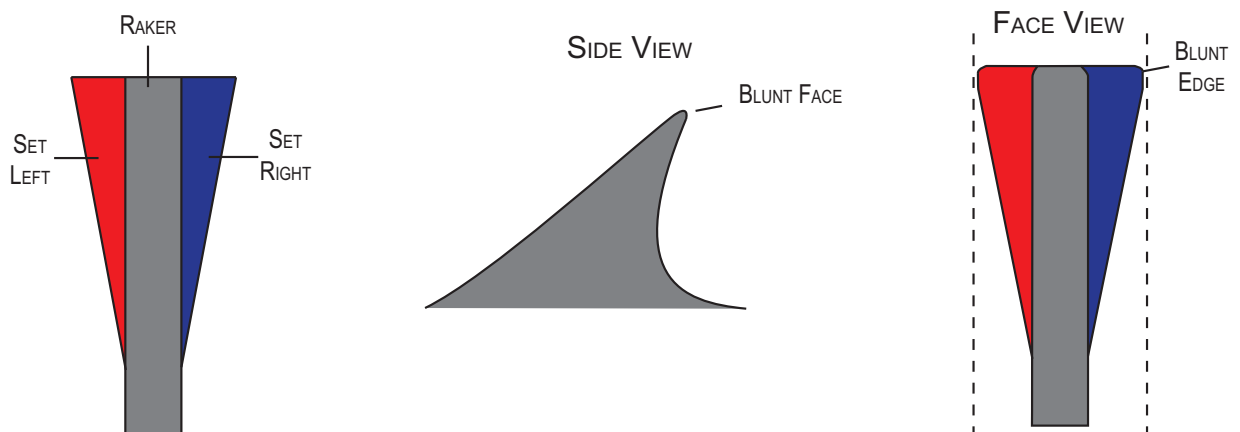

On a dull blade, you will notice the primary cutting surface has become dull. The blade is no longer sharp and therefore can no longer cut efficiently. You will also notice that the edges of the set teeth have also become dull. Bluntness in this area means the surface of the board will be poor because the fibers on the edge of the cut are not being cut, they are being abraded.

### How this affects cutting performance

During the cutting process, the cutting surfaces, both the face and the edge, become blunt and this means that the blade is “chewing” its way through the wood, instead of cutting, and this results in;

- Slower feed rates.
- Heating of the blade and loss of blade tension
- Higher horse power and fuel consumption from the engine.
- Poor surface finish of cut.
- Wavy cuts.
- Accelerated formation of gullet cracks.
- Accelerated formation of cracks on the back of blade caused by the blade being pushed back against rear flange of the blade guide roller.

### Benefits of Frequently Changing Blades

It is better to change the blades more frequently than less frequently.

As soon as the operator notices the performance of the blade deteriorating the operator should change the blade.

The benefits of changing a dull blade, rather than just keeping on cutting are;

Significant reduction in:

- Blade costs.
- Energy costs.
- General Maintenance costs.

Significant improvements in:

- Daily production.
  - Quality of the surface finish.
  - Accuracy of the cut.
-

## 7.3 ReSharp process

# Wood-Mizer®

## RESHARP PROCESS

The ReSharp process is designed to take a used, dull blade and bring it back to maximum performance.

There are three basic stages in the ReSharp operation which can be performed in different sequences dependent on the equipment that you have, the quality of the incoming blades and the final result required.

- Grinding
- Washing
- Setting

**Grinding:** The Wood-Mizer CBN wheel grinders are designed to sharpen blades with a full plunge grind. With proper alignment, the CBN wheel is designed to match the blade profile, allowing the blade to be sharpened properly to continue cutting at high efficiency. This process gives you a sharp face and sharp edges.

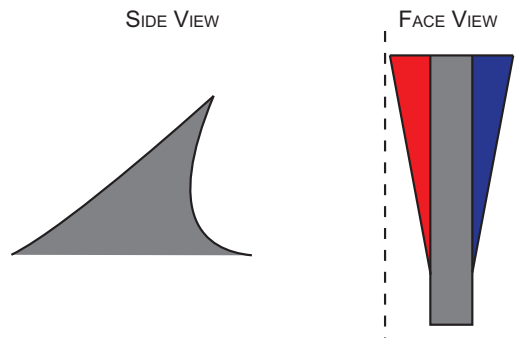
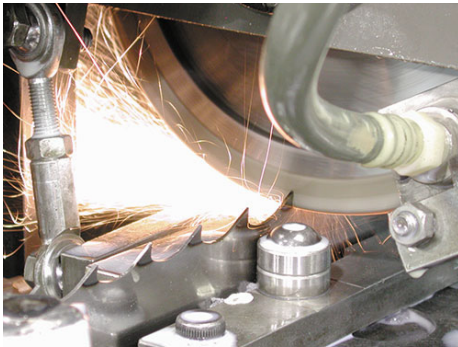

**Washing:** Cleaning and “de-burring” the blade has to be done manually or using a Wood-Mizer wash tank to ensure accurate grinding and setting.

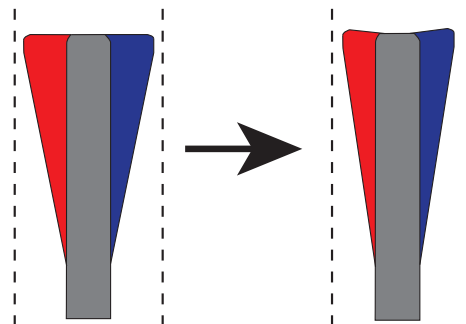

When using a Wood-Mizer wash tank, blades are run through a cycle that cleans, deburrs, and washes the blade in solvent. The wash cycle also includes a set of rollers to pinch the blades to flatten and equalise the set. This allows for the blades to be properly set during the setting process.

If you do not have a wash tank you must “de-burr” to remove the burr on the inside of the blade that is created during the grinding process. This is essential in order to get accurate setting on both sides of the blade. “De-burring” can be done manually by running a piece of hard wood along the tips of teeth on the “inside” of the blade.

**Setting:** Process by which the teeth are set to the left and to the right.

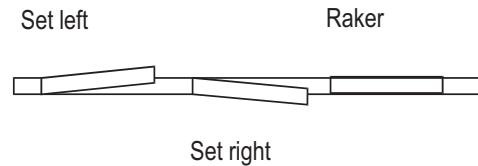

The setting process creates the clearance needed for the body of the blade to be able to slide through the timber without dragging.

Wood-Mizer has a range of Setters:

- Simple manual single tooth setters
- Simple manual dual tooth setters
- Powered dual tooth setters
- Semi-automatic electronic controlled setters
- Fully automatic computer controlled setters

### ReSharp Process Options

Remember our aim is for a perfectly sharpened blade

#### Dull Blade

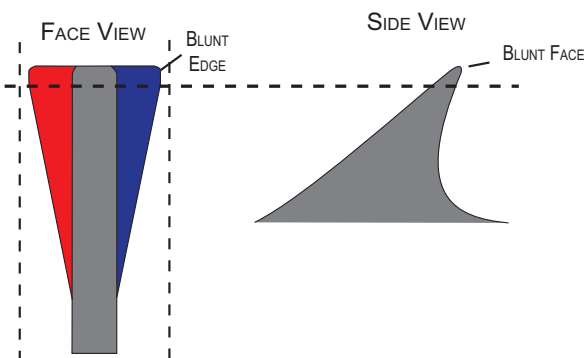

You must ensure you grind the blade past all blunt edges, face and side, in order to have a sharp blade.

### Sharp Blade

FACE VIEW

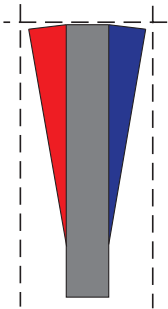

This is a sharp blade but the cutting performance will not be quite as good as a blade with a perpendicular face.

- Only 1/3 of cutting surface is perpendicular to the fibers.
- Blade will be more likely to “wander” in the cut.

### Perfectly Sharp Blade

FACE VIEW

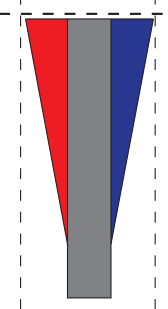

SIDE VIEW

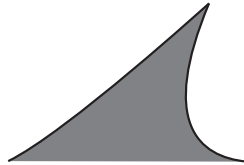

This is a perfectly sharpened and set blade.

- Maximum cutting performance
-



### ReSharp Installation - with Wash Tank

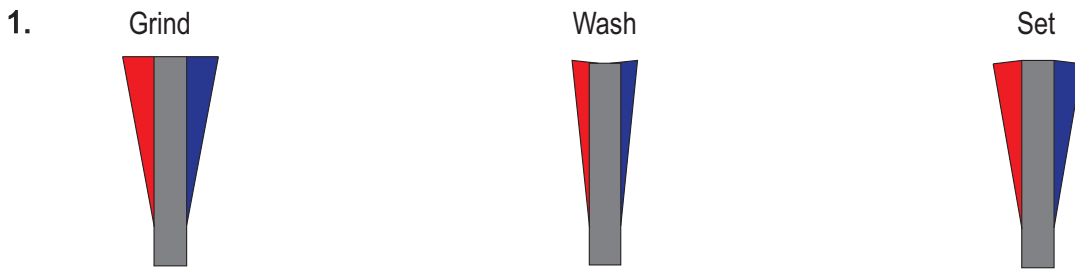

This sequence is acceptable if the incoming blade is in good condition

---

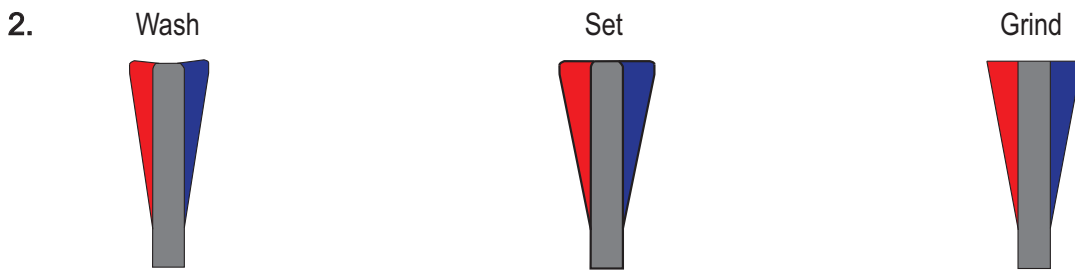

This sequence is acceptable if the incoming blade is in good condition

---

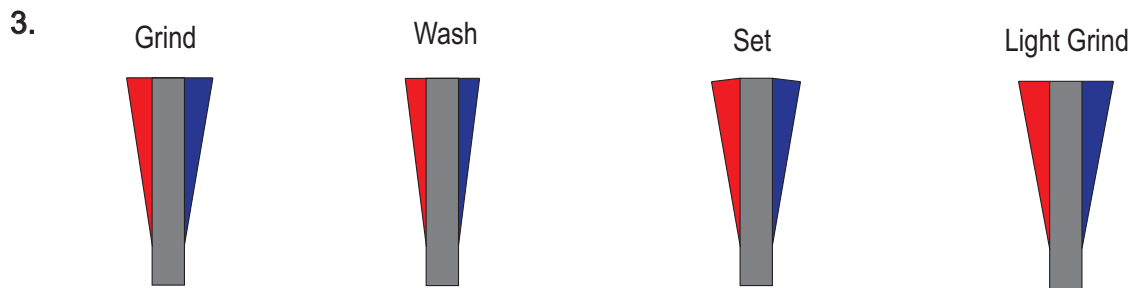

This sequence should be used if the incoming blade is in a very blunt, dull or damaged condition

---

### ReSharp Installation - without Wash Tank

1.



This sequence is acceptable if the incoming blade is in good condition

---

2.

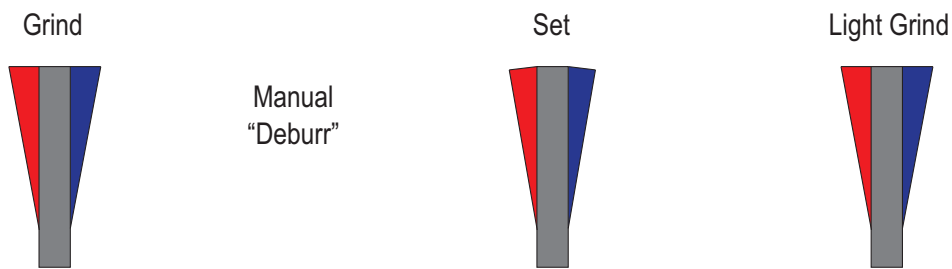

This sequence should be used if the incoming blade is in a very blunt, dull or damaged condition

---

## SECTION 8 REPLACEMENT PARTS

### 8.1 How To Use The Parts List

- Use the table of contents or index to locate the assembly that contains the part you need.
- Go to the appropriate section and locate the part in the illustration.
- Use the number pointing to the part to locate the correct part number and description in the table.
- Parts shown indented under another part are included with that part.
- Parts marked with a diamond (◆) are only available in the assembly listed above the part.

See the sample table below. Sample Part #A01111 includes part F02222-2 and subassembly A03333. Subassembly A03333 includes part S04444-4 and subassembly K05555. The diamond (◆) indicates that S04444-4 is not available except in subassembly A03333. Subassembly K05555 includes parts M06666 and F07777-77. The diamond (◆) indicates M06666 is not available except in subassembly K05555.

<b>Sample Assembly</b>				
REF.	DESCRIPTION (◆ Indicates Parts Available In Assemblies Only)	PART #	QTY.	
	<b>SAMPLE ASSEMBLY, COMPLETE (INCLUDES ALL INDENTED PARTS BELOW)</b>	A01111	1	
1	Sample Part	F02222-22	1	
	Sample Subassembly (Includes All Indented Parts Below)	A03333	1	
2	Sample Part (◆ Indicates Part Is Only Available With A03333)	S04444-4	1	◆
	Sample Subassembly (Includes All Indented Parts Below)	K05555	1	
3	Sample Part (◆ Indicates Part Is Only Available With K05555)	M06666	2	◆
4	Sample Part	F07777-77	1	

#### To Order Parts:

- From Europe call our European Headquarters and Manufacturing Facility in Kolo, Poland at **+48-63-2626000**. From the continental U.S., call our toll-free Parts hotline at **1-800-448-7881**. Have your customer number, vehicle identification number, and part numbers ready when you call.
- From other international locations, contact the Wood-Mizer distributor in your area for parts.

**8** **REPLACEMENT PARTS**  
*Blade Support Assembly*

**8.2 Blade Support Assembly**

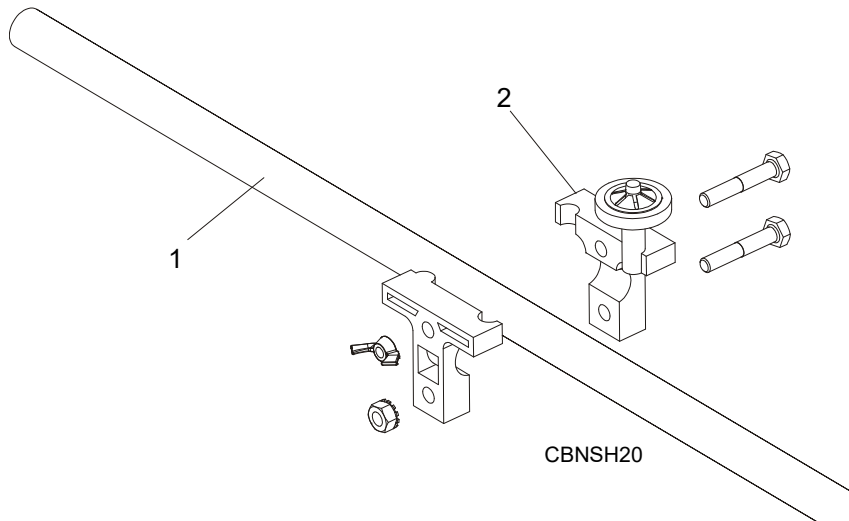

REF.	DESCRIPTION (◆ Indicates Parts Available In Assemblies Only)	PART #	QTY	
1	<b>BLADE SUPPORT ASSEMBLY, COMPLETE</b>	087518-1	3	
1	<b>GUIDE KIT, BLADE SUPPORT</b>	A10617	1	

8.3 Grinder Assembly

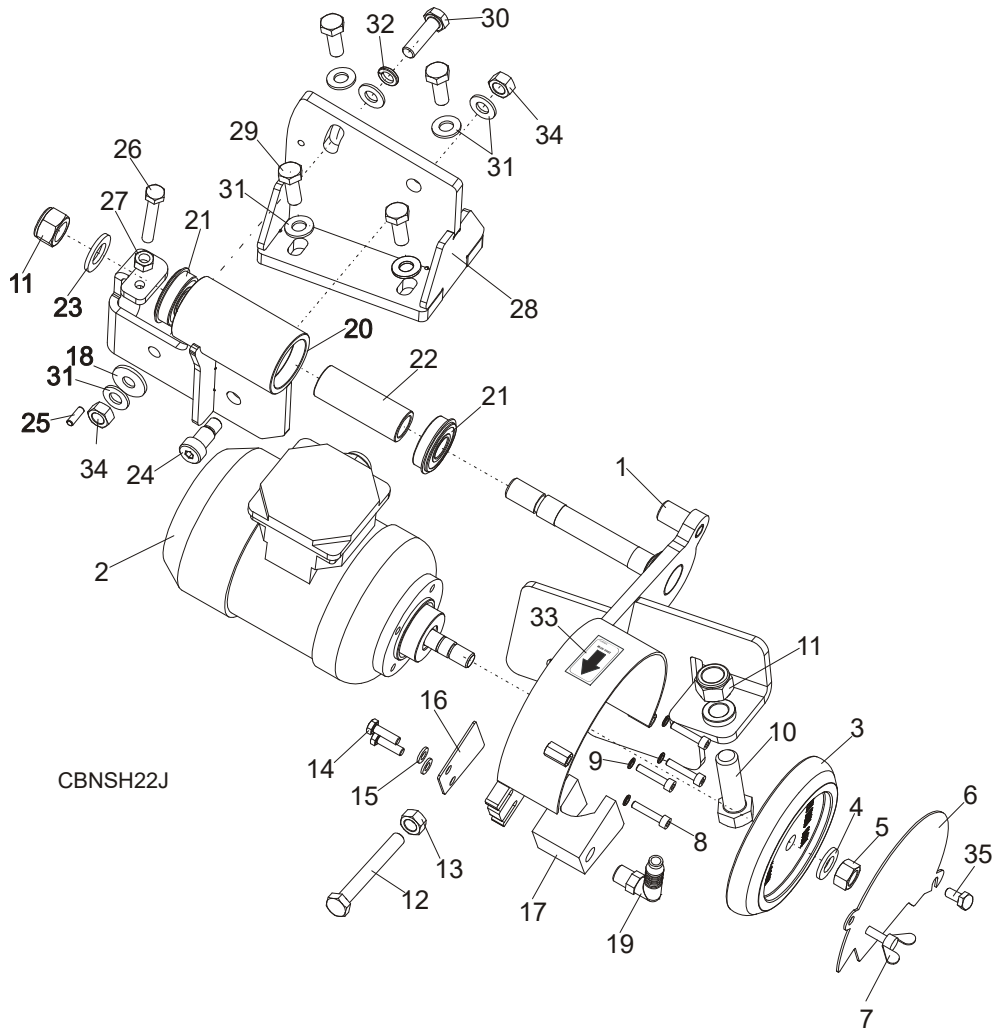

REF.	DESCRIPTION (◆ Indicates Parts Available In Assemblies Only)	PART #	QTY
	<b>SHARPENER HEAD, BMS250 COMPLETE</b>	097030	1
1	Arm, Sharpener Head Weldment	507795-1	1
2	Motor, SEKh 56-2C2/162A 230V 50Hz	089383	1
	Motor, SEKh 56-2C2/162A 230V 60Hz UL	089383-UL	1
	Motor, SEKh 56-2C2/162A 110V 60Hz UL	093490-UL	1
	Capacitor, BMS250MU Start	061137	1
	Fan, SEKh 56-2C2/162F 230V60Hz Motor	083961	1

# 8

## REPLACEMENT PARTS

### Grinder Assembly

3	Wheel, 9°/29° 7/8TS .220TH 5" BMS250 Grinding CBN Profile	030380	1	
	Wheel, 10°/30° 7/8" TS .250TH 5" BMS250 Grinding CBN Profile	030381	1	
	Wheel, 13°/29° 7/8TS .300TH 5" BMS250 Grinding CBN Profile	030389	1	
	Wheel, 12°/28° .656TS .200TH 5" BMS250 Grinding CBN Profile	030395	1	
	Wheel, 4°/32° 7/8TS .250TH 5" BMS250 Grinding CBN Profile	050744	1	
	Wheel, 13°/29° 1-1/8TS .330TH 5" BMS250 Grinding CBN Profile	053033	1	
	Wheel, 10°/30° 1-1/8TS .330TH 5" BMS250 Grinding CBN Profile	053034	1	
	Wheel, 7°/34° 7/8" TS .295TH 5" BMS250 Grinding CBN Profile	053294	1	
	Wheel, 10°/30° 3/4TS .260TH 5" BMS250 Grinding CBN Profile	053358	1	
	Wheel, 10°/30° 1/2TS .160TH 5" BMS250 Grinding CBN Profile	053411	1	
	Wheel, 7°/34° 1-1/8TS .330TH 5" BMS250 Grinding CBN Profile	053446	1	
	Wheel, 5" 7°/39.5° 7/8" TS .33TH BMS250 Grinding CBN Profile	066268	1	
	Wheel, 5" 7°/47° 0.875"TS 0.35"TH CBN	077722	1	
	Wheel, 5" 10°/30° Vortex .875"TS CBN	077698	1	
	Wheel, 5" 10°/30° 1"TS 0.33"TH CBN	077708	1	
	Wheel, 5" 7°/39.5° 1.25"TS 0.4"TH BMS250 Grinding CBN Profile	077704	1	
Grinding Wheel, 5" VORTEX	077698	1		
4	Washer, M12 Flat Zinc	F81056-1	1	
5	Nut, M12x1,25-8 Hex Zinc	F81034-8	1	
6	Cover, Front Guard	088247-1	1	
7	Bolt, M6x10 FE/ZN5 DIN-316/BN-276	F81001-49	1	
8	Screw, M5x25 -8.8 Hex Socket Head Cap Zinc	F81000-7	4	
9	Washer, 10.2 Split Lock Zinc	F81055-2	1	
10	Bolt, M16x50-8.8 Hex Flat Head	F81006-38	1	
11	Nut, M16-8 Hex Nylon Zinc Lock	F81036-2	2	
12	Bolt, M10-80-8.8 Fe/Zn5 Hex Head Full Thread	F81003-76	1	
13	Nut, M10 -8-B Hex Zinc	F81033-3	1	
14	Bolt, M6x20-8.8 Hex Head Full Thread Zinc	F81001-2	2	
15	Washer, 6.4 Flat Zinc	F81053-1	2	
16	Washer, Oiler Spacer	094060-1	1	
17	Oiler, BMS 200/250; 0.500"TS-0.875"TS	093193	1	
	Oiler, BMS 200/250; 7/8"-1-1/4"TS	509580 <sup>1</sup>	1	
	Oiler, Vortex BMS 200/250	522706	1	
18	Washer, 10.5 Zinc Flat Special	F81055-6	1	
19	Stud, WES 10/R 1/4 Elbow	088379	1	
20	Bushing, Sharpener Vertical Pivot	507787-1	1	
21	Bearing w/Ring	086395	2	
22	Bushing, Sharpener Head Spacer	092672	1	
23	Washer, 17 Flat Zinc	F81058-1	1	
24	Screw, 12/M10x16 12.9 Bossard Socket Head Shoulder	F81003-64	1	
25	Pin, 5x16 Roll Fe/Zn Zinc	F81044-3	1	
26	Bolt, M8x50 - 8.8 Hex Head Full Thread Zinc	F81002-19	1	
27	Nut, M8 Hexagon, Grade 5.8 Free Zinc	F81032-1	1	

## REPLACEMENT PARTS

### Grinder Assembly

**8**

<b>28</b>	Base Weldment, Sharpener Head	507785-1	1	
<b>29</b>	Bolt, M10X25-8.8-Fe/Zn5	F81003-11	4	
<b>30</b>	Bolt, M10x35 - 8.8 Hex Head Full Thread Zinc	F81003-17	4	
<b>31</b>	Washer, 10.5 Flat Zinc	F81055-1	3	
<b>32</b>	Washer, 5.1 Split Lock Zinc	F81052-2	4	
<b>33</b>	Decal, 2800 RPM Motor Rotation Direction	S20097C <sup>2</sup>	1	
<b>34</b>	Nut, M10-8-B Nylon Hex Zinc Lock	F81033-1	2	
<b>35</b>	Bolt, M6x12-8.8 Hex Head Full Thread Zinc	F81001-7	1	
	OIL GRINDING, CBN (5 liters) ACP-1E (European Market)	083559-1	1	
	OIL GRINDING, CBN (5 gallons) CE150S (US Market)	010740	1	

<sup>1</sup> Oiler #509580 (revision B or earlier) are only compatible for sharpening teeth up to 1-1/8" tooth spacing. Please contact Wood-Mizer Customer Service.

<sup>2</sup> Belongs to 088855 - BMSBS250 Decal Kit.

# 8 REPLACEMENT PARTS

## Sharpener Mounting Plate

### 8.4 Sharpener Mounting Plate

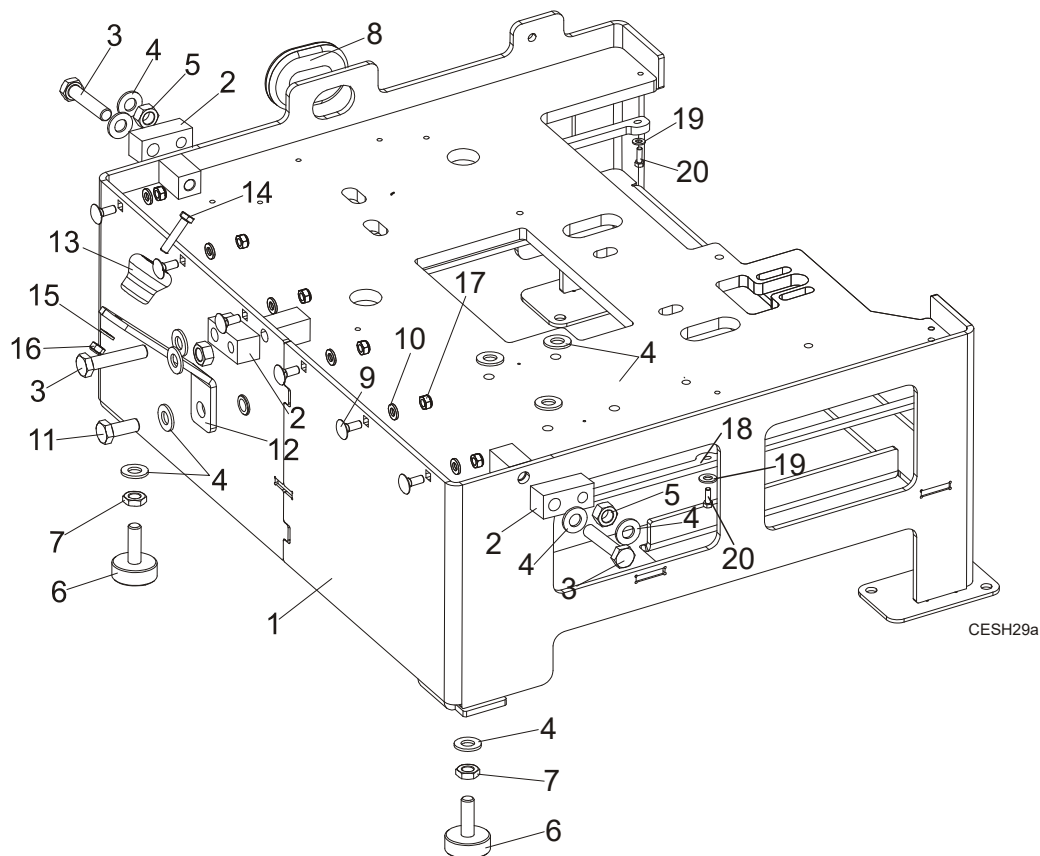

REF.	DESCRIPTION (◆ Indicates Parts Available In Assemblies Only)	PART #	QTY
1	PLATE, BMSBS250 AC SHARPENER MOUNTING	507777-1	1
2	ARM, BLADE MOUNTING PTD	093183-1	3
3	BOLT, M10X50MM, HEX HEAD FULL THREAD ZINC	F81003-4	3
4	WASHER, 10.5 FLAT ZINC	F81055-1	13
5	NUT, M10-8-B-FE	F81033-3	3
6	foot, base adjust	092839	2
7	NUT, 10MM x 1.25 NYLON	F81033-6	2
8	SEAL RUBBER, WIRE INSIDE DIA 26MM	085613	1
9	Bolt, M6x16 8.8 Hex Head Full THREAD ZINC	F81001-36	6
10	Washer, 6.4 Flat ZINC	F81053-1	6
11	BOLT, M10X25-8.8-FE/ZN5	F81003-11	1
	BRACKET, CBN-AC COVER WELDMENT	087824	1
12	Bracket, Cover Weldment	087826-1	1
13	Bumper, Cover Bracket	087825	1
14	Bolt, M6x30 5.8 Hex Zinc	F81001-13	1



# REPLACEMENT PARTS

## Blade Clamp Assembly

8

15	Washer, 6.4 Flat Zinc	F81053-1	1	
16	Nut, M6-8-B Hex Nylon Zinc Lock	F81031-2	1	
17	Nut, M6-8-B Hex Nylon Zinc Lock	F81031-2	6	
18	Plate, Sharpener Base	507782	1	
19	Washer, M5, Flat Zinc	f81052-1	7	
20	Bolt, M5x16-8.8 Hex Head Full Thread Zinc	F81000-20	7	

### 8.5 Blade Clamp Assembly

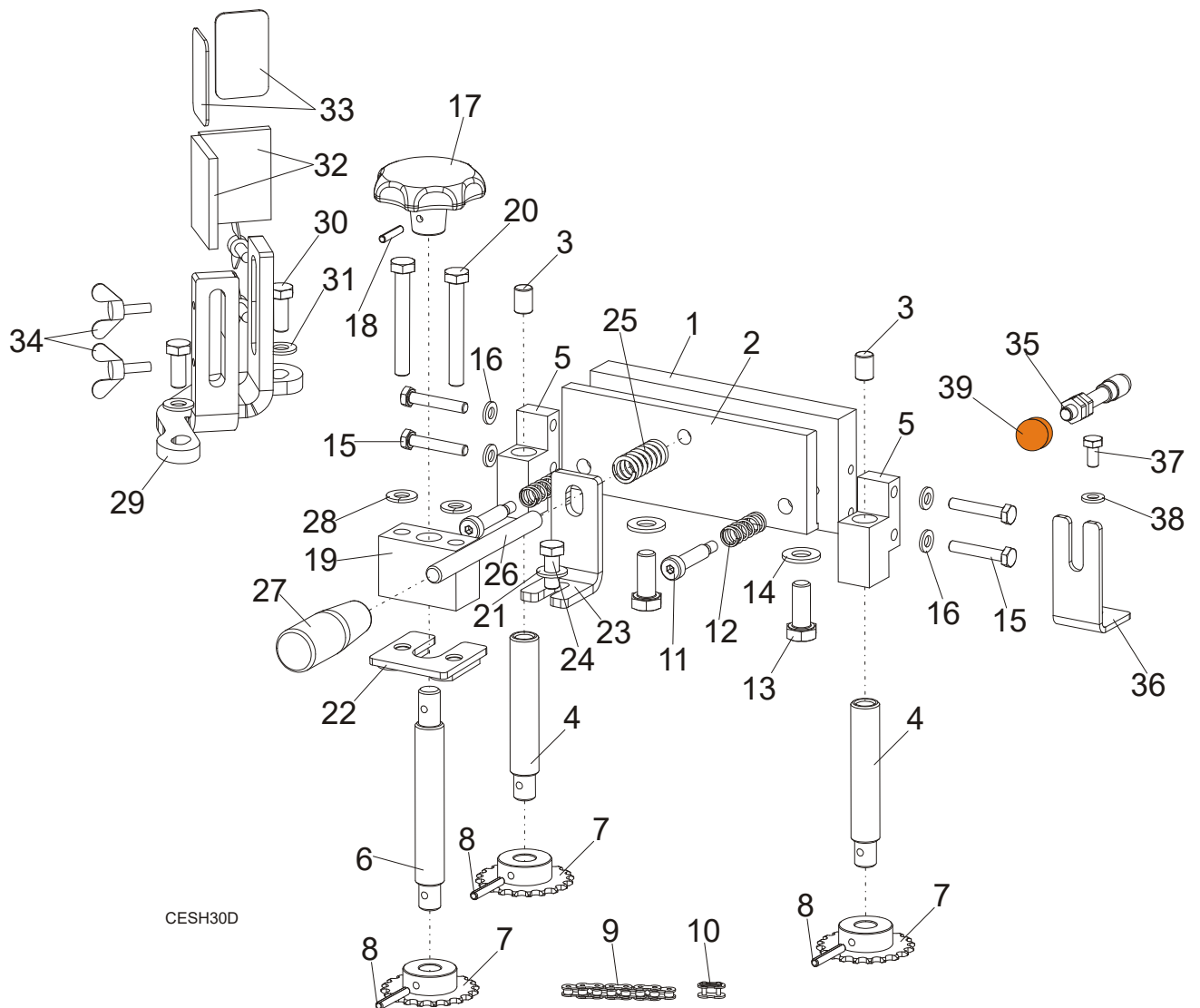

REF.	DESCRIPTION (◆ Indicates Parts Available In Assemblies Only)	PART #	QTY	
------	--------------------------------------------------------------	--------	-----	--

## 8

**REPLACEMENT PARTS***Blade Clamp Assembly*

	<b>BLADE CLAMP WITH BLADE HEIGHT ADJUSTMENT</b>	<b>098512</b>	<b>1</b>	
1	PLATE, FIXED CLAMP ZINC-PLATED	097025-1	1	
2	PLATE, MOVING CLAMP ZINC-PLATED	097026-1	1	
3	ROLLER, $\phi$ 10x14 CYLINDRICAL	096864	2	
4	SCREW, BLADE HEIGHT ADJUSTMENT ZINC-PLATED	096865-1	2	
5	BLOCK, THREADED ZINC-PLATED	096866-1	1	
6	SCREW, BLADE HEIGHT ADJUSTMENT DRIVING ZINC-PLATED	096867-1	1	
7	SPROCKET, 05B-1 Z20 8x3-12H7 ZINC-PLATED	098513-1	3	
8	PIN, 4X30 SPRING-TYPE STRAIGHT ZINC-PLATE	F81044-7	3	
	CHAIN, BLADE HEIGHT ADJUSTMENT - COMPLETE	098515	1	
9	CHAIN, 05B-1-73 DRIVING	098516	1	
10	LINK, QRC05B-1 MASTER	098517	1	
11	SCREW, 8/M6X30-12.9 SOCKET HEAD SHOULDER	F81001-18	2	
12	SPRING, 9X30X1.2 COMPRESSION	088368	2	
13	BOLT, M10X25-8.8 HEX HEAD FULL THREAD ZINC	F81003-11	2	
14	WASHER, 10.5 FLAT ZINC	F81055-1	2	
15	BOLT, M6x35 8.8 HEX HEAD ZINC	f81001-71	4	
16	WASHER, 6.4 FLAT ZINC	F81053-1	4	
17	KNOB, DIN6336-GG-63-B12-C BLADE HEIGHT ADJUSTMENT	098514	1	
18	PIN, PN-EN ISO8752-4X20 ST AOP ROLL	f81044-11	1	
19	BLOCK, ADJUSTMENT KNOB MOUNTING ZINC-PLATED	097062-1	1	
20	BOLT, M8X60-8.8 HEX HEAD ZINC	f81002-54	2	
21	WASHER, 8.4 FLAT ZINC	f81054-1	1	
22	NUT, M8 DOUBLE ZINC	503104-1	1	
23	BRACKET, BLADE CLAMP SPRING	097069-1	1	
24	BOLT, M8X20-8.8 HEX HEAD FULL THREAD ZINC	F81002-4	1	
25	SPRING	087376	1	
26	STUD-BOLT, 1M10X90-8.8-FE/ZN5	f81003-85	1	
27	GRIP, L70 THREAD M10 13870M10	089445	1	
28	WASHER, 8.2 SPLIT LOCK ZINC	f81054-4	2	
	<b>COMPLETE BLADE WIPER</b>	<b>098526</b>	<b>1</b>	
29	BRACKET WELDMENT, BLADE WIPER MOUNT	508426-1	1	
30	BOLT, M8X20-8.8 HEX HEAD FULL THREAD ZINC	F81002-4	2	
31	WASHER, 8.4 FLAT ZINC	f81054-1	2	
32	WIPER, FLEXAM 3T2862 BLADE	087608	2	
33	BRACE, BLADE WIPER	088098-1	2	
34	SCREW, M5X16 DIN 316 THUMB	f81000-44	4	
35	<b>INDUCTIVE SENSOR 48VDC 200MA XS+OPTIONS (not in BMS250 EC Version)</b>	088268	1	
36	<b>BRACKET, MAGNETIC SHUTOFF SENSOR MOUNT (NOT IN BMSBS250 EC VERSION)</b>	088366-1	1	
37	<b>BOLT, M6X12MM HEX HEAD ZINC (NOT IN BMS250 EC VERSION)</b>	f81001-7	1	
38	<b>WASHER, 6.4 FLAT ZINC (NOT IN BMS250 EC VERSION)</b>	F81053-1	1	
39	<b>MAGNET, ORANGE PAINTED</b>	S10519-1	1	

**8.6 Oil Pump/Pan, Control Box, BMS250**

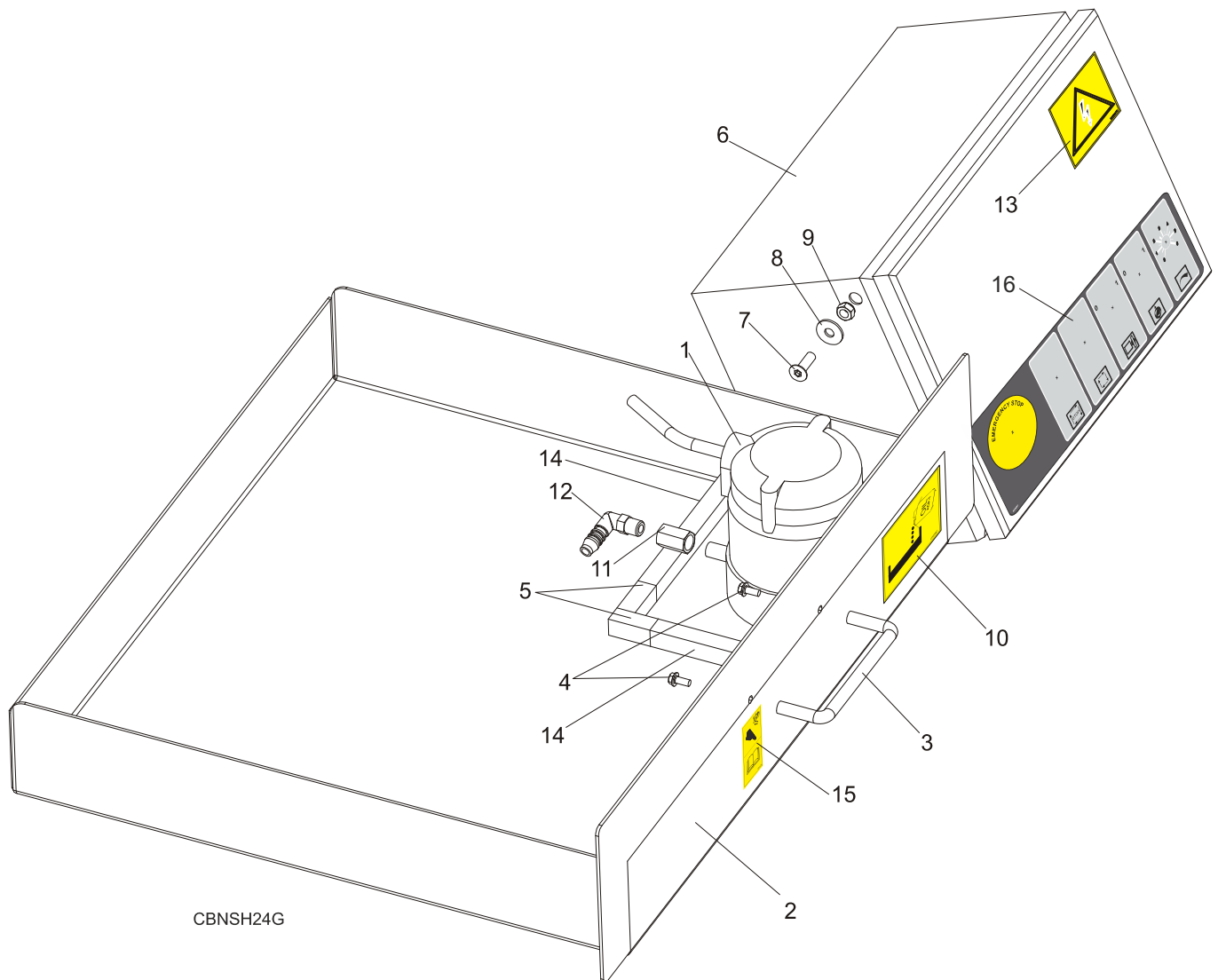

REF.	DESCRIPTION (◆ Indicates Parts Available In Assemblies Only)	PART #	QTY
1	PUMP, AUTO SHARPENER COOLANT	P09836	1
2	PAN, SHARPENER OIL	088201	1
3	HANDLE, 4" W/BOLTS	P08065	1
4	BOLT #8-32x3/8	F05018-5	2
5	MAGNET 50X30X15, OIL FILTER	516220	2
6	BOX, CN SHARPENER CONTROL, 230V 50Hz See Section 7.8	092628	1
	BOX, CBN SHARPENER CONTROL, 230V 60Hz See Section 7.10	092628-5	1
	BOX, CBN SHARPENER CONTROL, 110V 60Hz See Section 7.12	092628-6	1

# 8

## REPLACEMENT PARTS

*Oil Pump/Pan, Control Box, BMS250*

7	SCREW, M6x20-10.9 Fe/Zn5 DIN-7991	F81001-17	2	
8	WASHER, 6.5 FLAT ZINC	F81053-11	2	
9	NUT, M6-8-B HEX NYLON ZINC LOCK	f81031-2	2	
10	DECAL - „OIL" PICTOGRAM	095961 <sup>1</sup>	1	
11	FITTING, 1/4 F.TH./1/4 F.TH.893-302-000-4	090808	1	
12	STUD, WES 10/R 1/4 ELBOW	088379	1	
13	DECAL, ELECTRIC POWER WARNING	S10364-P3 <sup>1</sup>	1	
14	MAGNET 100X30X15, OIL FILTER	516192	2	
15	DECAL, CLEAN THE SCHARPENER EVERY 8 HOURS	524490	1	
16	DECAL, ELECTRIC BOX BS250/BMS250	533687	1	
	KEY, ELECTRIC BOX	083850	1	
	HOSE, WATER LUBE STOCK	R01885	0.9 m	

<sup>1</sup> Belongs to 088855 - BMS250 Decal Kit.

**8.7 Oil Pump/Pan, Control Box, BMS200**

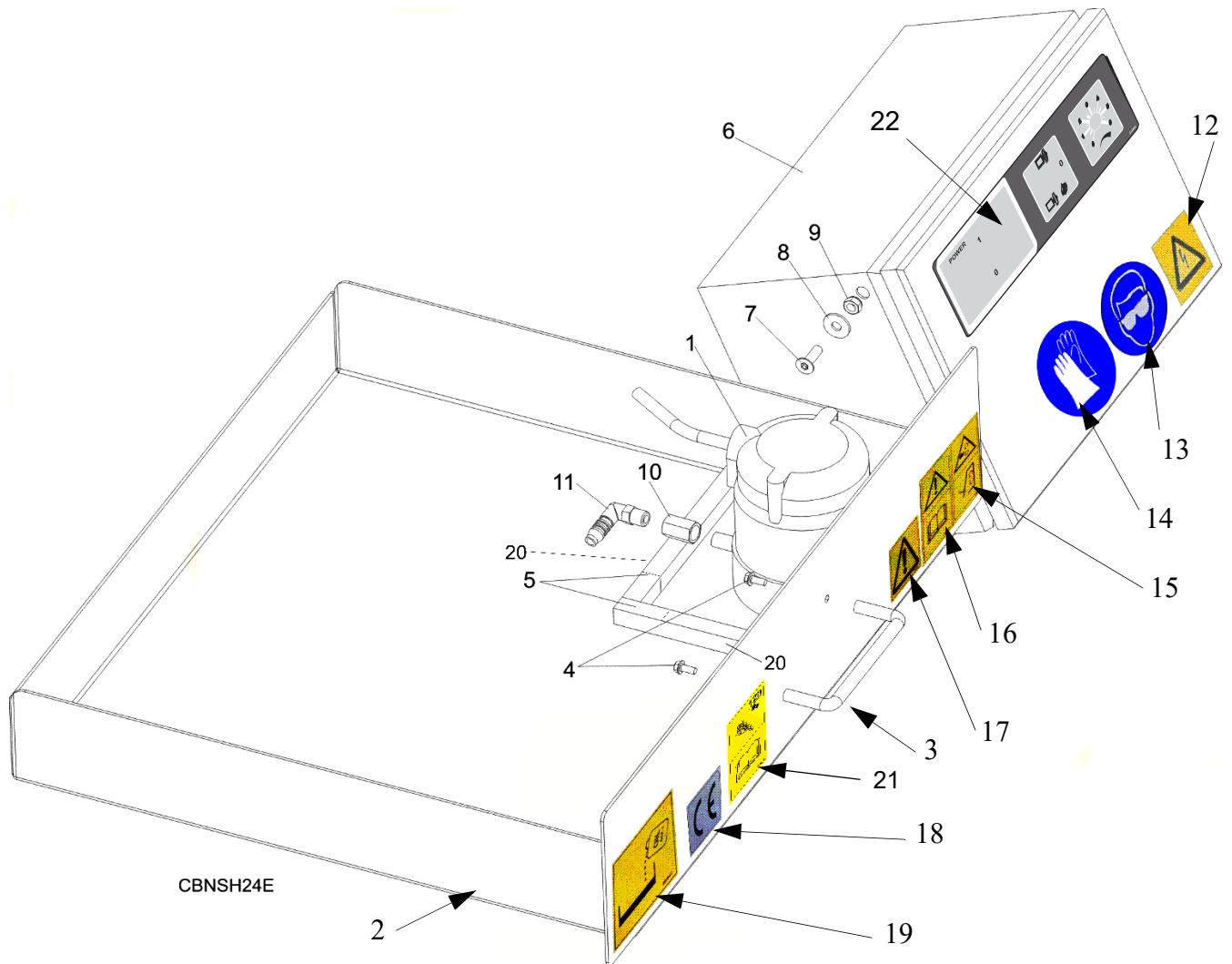

REF.	DESCRIPTION (◆ Indicates Parts Available In Assemblies Only)	PART #	QTY
1	PUMP, AUTO SHARPENER COOLANT	P09836	1
2	PAN, SHARPENER OIL	088201	1
3	HANDLE, 4" W/BOLTS	P08065	1
4	BOLT #8-32x3/8	F05018-5	2
5	MAGNET 50X30X15, OIL FILTER	516220	2
6	BOX, BMS200A SHARPENER CONTROL 230V 50Hz	507241	1
	BOX, BMS200AU SHARPENER CONTROL 230V 60Hz	507241-5	1
	BOX, BMS200MU SHARPENER CONTROL 110V 60Hz	507241-6	1
7	SCREW, M6x20-10.9 Fe/Zn5 DIN-7991	F81001-17	2

## 8

**REPLACEMENT PARTS***Oil Pump/Pan, Control Box, BMS200*

8	WASHER, 6.5 FLAT ZINC	F81053-11	2	
9	NUT, M6-8-B HEX NYLON ZINC LOCK	f81031-2	2	
10	FITTING, 1/4 F.TH./1/4 F.TH.893-302-000-4	090808	1	
11	STUD, WES 10/R 1/4 ELBOW	088379	1	
	KIT, BMS200 DECALS	509256	1	
12	DECAL, ELECTRIC POWER WARNING	s10364-p3	1	
13	DECAL, EYE WARNING, SMALL	S12004G-1	1	
14	DECAL, PICTOGRAM, "USE SAFETY GLOVES"	510080	1	
15	DECAL , CLOSE ALL GUARDS BEFORE OPERATING	099220	1	
16	DECAL, READ OPERATOR'S MANUAL (PICTOGRAM)	096317	1	
17	DECAL, GENERAL WARNING "!"	086362	1	
18	DECAL, CE CERTIFIED SAWMILL (SMALL)	P85070	1	
19	DECAL - PICTOGRAM "OIL"	095961	1	
20	MAGNET 100X30X15, OIL FILTER	516192	2	
21	DECAL, CLEAN THE SHARPENER EVERY 8 HOURS	524490	1	
22	DECAL, ELECTRICAL BOX BS200/BMS200	533689	1	
	KEY, ELECTRIC BOX	083850	1	

8.8 Cam Assembly

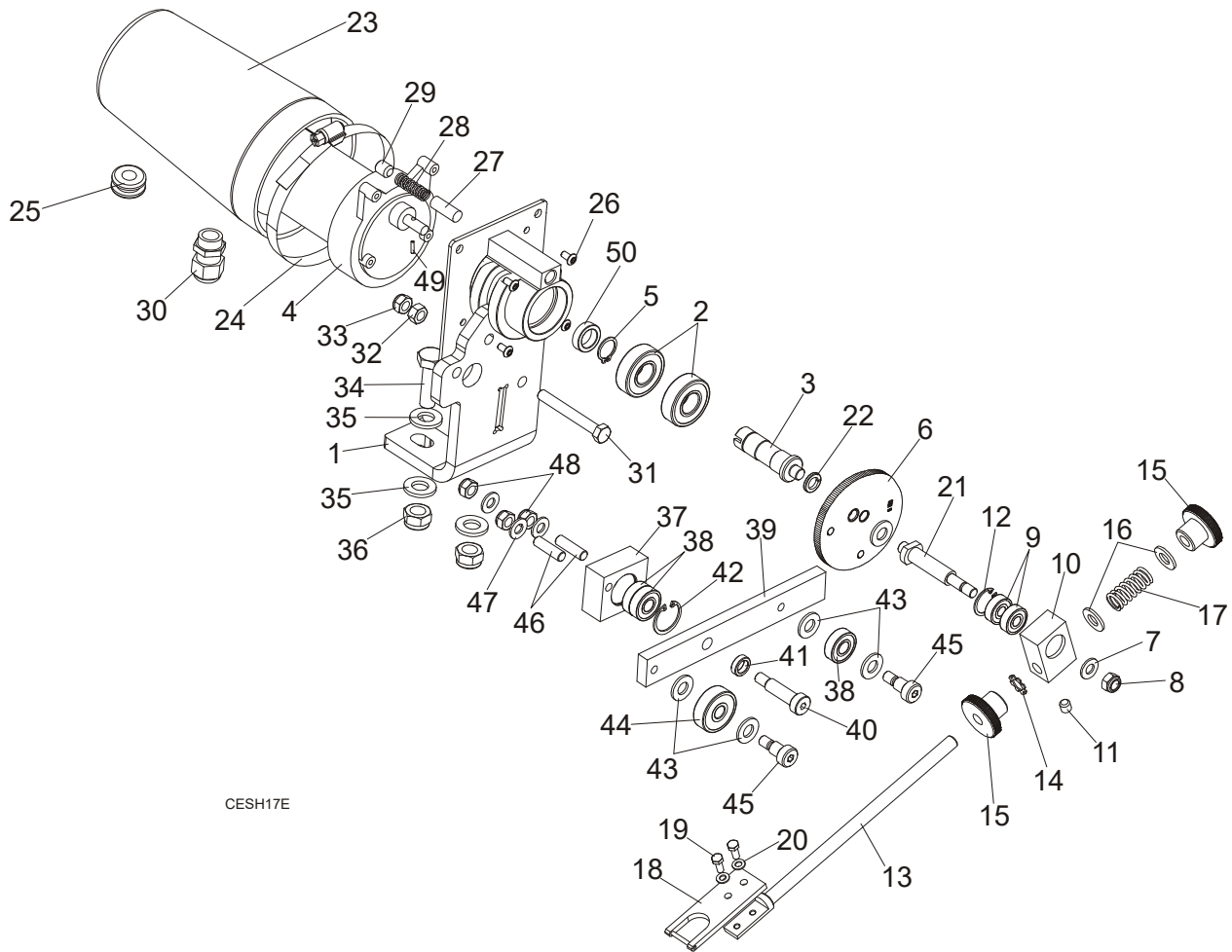

CESH17E

REF.	DESCRIPTION (◆ Indicates Parts Available In Assemblies Only)	PART #	QTY
	<b>CAM &amp; INDEX ARM DRIVE ASSEMBLY, COMPLETE</b>	098520	1
1	HOUSING WDMT, INDEX CAM DRIVE SHAFT PTD	507790-1	1
2	BEARING, 6203-2RS	086114	2
3	SHAFT, CAM DRIVE	087366	1
4	MOTOR,CURRENT APPLICATIONS 1/30HP 12VDC GEAR	079214	1
	Gear Kit, Motor Replacement (Current Application)	061232	1
	Brush Kit, Gear Motor Replacement (Current Application)	061234	1
	Shaft Kit, Gear Motor Replacement (Current Application)	061233	1
5	SNAP RING PN-M/85111	F81090-21	1
6	CAM, AGA PROFILE	057401	1
	CAM, PROFILE INDEX 7/8" - 1 1/4" TOOTH SPACING	057401 <sup>1</sup>	1
	CAM, PROFILE INDEX 5/8" - 7/8" TOOTH SPACING	010741 <sup>1</sup>	1

## 8

**REPLACEMENT PARTS***Cam Assembly*

	CAM, PROFILE INDEX 1/2" - 5/8" TOOTH SPACING	060091 <sup>1</sup>	1	
7	WASHER, 8.4 FLAT ZINC	F81054-1	1	
8	NUT, M8-8-B HEX NYLON ZINC LOCK	F81032-2	1	
	REPAIR KIT, SHARPENER INDEXER	097462	1	
9	BEARING, 608-2RS ROLLER	086197	2	
10	BLOCK, INDEX - ZINC	087373-1	1	
11	SCREW, M8X8-33H HEX SOCKET SET FLAT POINT	F81014-1	1	
12	RING, W22 RETAINING	F81090-7	1	
13	PAWL WELDMENT, BLADE INDEX - ZINC	087374-1	1	
14	WASHER, 10.5 EXTERNAL RING	F81055-3	1	
15	WASHER, PUSH PAWL	087375	2	
16	WASHER, 10.5 FLAT ZINC	F81055-1	3	
17	SPRING, INDEX ARM	087376	1	
18	PUSHER, BLADE COMPLETE	093358	1	
19	BOLT, M5 X 12-5.8 HEX HEAD FULL THREAD ZINC	F81000-5	2	
20	WASHER, 5.3 FLAT ZINC	F81052-1	2	
21	SHAFT, INDEX CAM - ZINC	087372-1	1	
22	WASHER, 10.2 SPLIT LOCK ZINC	F81055-2	1	
23	GUARD, INDEX ARM MOTOR	507600	1	
24	TIE WRAP	F81095-5	1	
25	GROMMET, RUBBER	025248	1	
26	SCREW, 10-32X3/8 SBHC	F05004-56	4	
27	PIN, CAM BRAKE	518242	1	
28	SPRING, LC-045E-12	P04734	1	
29	SCREW, M12x12-33H HEX SOCKET FLAT POINT	F81004-15	1	
30	GLAND NUT, TRAILER HITCH, DW 11/H	085388	1	
31	BOLT, M8 X 65MM, HH, GRADE 5.8, ZINC	F81002-3	1	
32	NUT, M8 HEXAGON, GRADE 5.8 FREE ZINC	F81032-1	1	
33	NUT, M8-8-B HEX NYLON ZINC LOCK	F81032-2	1	
34	BOLT, M12x40 8.8 HEX HEAD FULL THR. ZINC	F81004-4	2	
35	WASHER, 13 FLAT ZINC	F81056-1	4	
36	NUT, M12-8 HEX NYLON ZINC LOCK	F81034-2	2	
	COMPLETE CAM LEVER	098522	1	
37	HOUSING, CAM LEVER BEARINGS ZINC-PLATED	098523-1	1	
38	BEARING, 6000 . 2RSR FAG	087471	3	
39	LEVER, CAM ZINC-PLATED	098521-1	1	
40	BOLT, 10/M8X30 12.9 ISO 7379 SHOULDER	F81003-81	1	
41	BUSHING, CAM LEVER SPACER ZINC-PLATED	098524-1	1	
42	RING, W26 PN/M-85111 INSIDE RETAINING	F81090-34	1	
43	WASHER, 10.5 FLAT ZINC	F81055-1	4	
44	BEARING, 6300.2 RSR CX	098519	1	
45	BOLT, 10/M8 X 12-12.9 ISO-7379	F81003-62	2	
46	STUD-BOLT, 1 M8X20-8.8 ZINC-PLATED	F81002-38	2	



47	WASHER, 8.4 FLAT ZINC	F81054-1	3	
48	NUT, M8-8-B HEX NYLON ZINC LOCK	F81032-2	3	
49	PIN, 1/8x5/8 DOWEL	F05012-31	1	
50	BUSHING SPACER FI 31 X 38 8	098615	1	

<sup>1</sup> Cam 057401 for blades with 7/8" - 1 1/4" tooth spacing provided as standard equipment on grinder. Cam 010741 for blades with 5/8" - 7/8" tooth spacing and Cam 060091 for blades with 1/2" - 5/8" tooth spacing available separately. **Cams for US market only.**

## 8.9 Cover Assembly

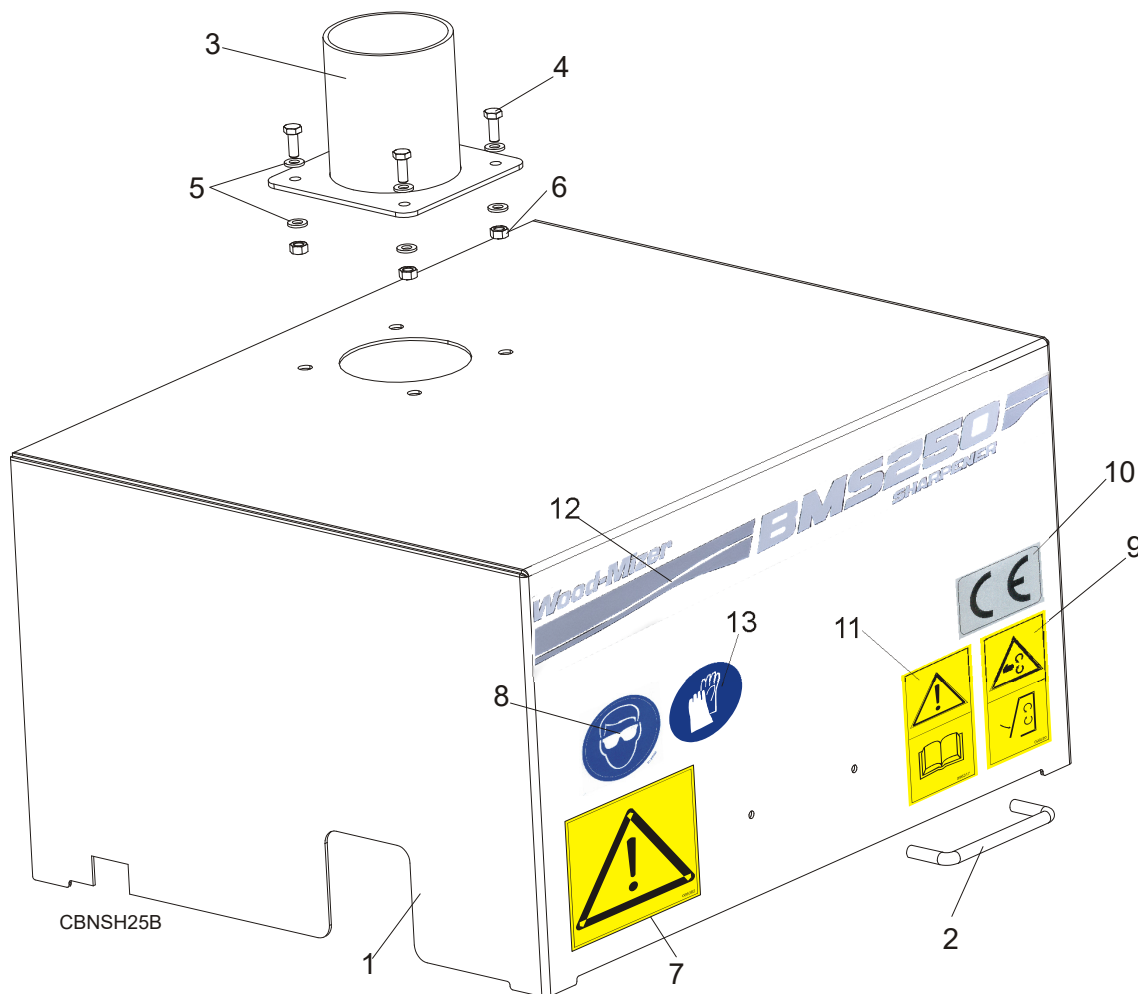

REF.	DESCRIPTION (◆ Indicates Parts Available In Assemblies Only)	PART #	QTY	
	<b>SHARPENER COVER, COMPLETE (not in BMS200 Version)</b>	088302	1	
1	Cover Weldment	088254-1	1	
2	Handle w/Bolts	P08065	1	
3	Pipe, Fume Exhaust Connection	087974-1	1	

## 8

**REPLACEMENT PARTS***Cover Assembly*

4	Bolt, M6x16 8.8 Hex Head Full Thread Zinc	F81001-15	4	
5	Washer, 6.4 Flat Zinc	F81053-1	8	
6	Nut, M6 –8 Hex Zinc	F81031-1	4	
7	<b>DECAL, GENERAL WARNING</b>	086362 <sup>1</sup>	1	
8	<b>DECAL, EYE WARNING, SMALL</b>	S12004G-1 <sup>1</sup>	1	
9	<b>DECAL , CLOSE ALL GUARDS BEFORE OPERATING</b>	099220 <sup>1</sup>	1	
10	<b>DECAL, CE CERTIFIED SAWMILL - SMaLL</b>	P85070 <sup>1</sup>	1	
11	<b>DECAL, READ OPERATOR'S MANUAL (PICTOGRAM)</b>	096317 <sup>1</sup>	1	
12	<b>DECALS250, BMS250</b>	510083 <sup>1</sup>	1	
13	<b>DECAL, PICTOGRAM, "USE SAFETY GLOVES"</b>	510080	1	

<sup>1</sup> Belongs to 088855 - BMS250 Decal Kit.

**8.10 Alignment Tool&Blade Profile Template**

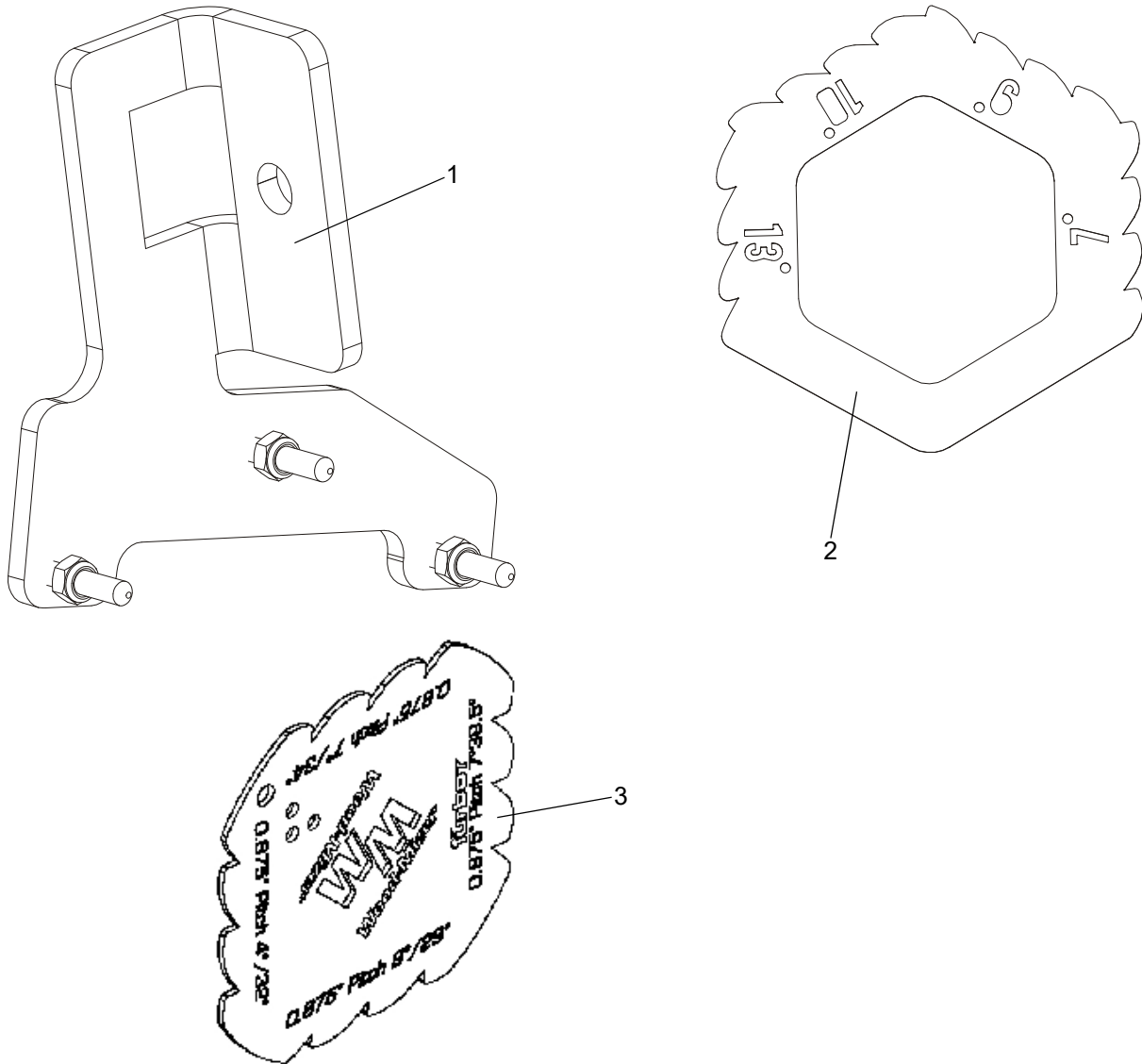

REF.	DESCRIPTION (◆ Indicates Parts Available In Assemblies Only)	PART #	QTY
1	ALIGNMENT TOOL, SHARPENER	088382	1
2	TEMPLATE, BLADE PROFILE	514846-1	1
3	ASSY, BLADE PROFILE GAUGES	109064	1

## EC declaration of conformity according to EC Machinery Directive 2006/42/EC, Annex II, 1.A

We herewith declare,

Wood-Mizer Industries sp. z o.o.  
114 Nagórna street, 62-600 Koło; Poland.

That the following described machine in our delivered version complies with the appropriate basic safety and health requirements of the EC Machinery Directive 2006/42/EC based on its design and type, as brought into circulation by us. In case of alteration of the machine, not agreed by us, this declaration is no longer valid.

Designation of the machine: **INDUSTRIAL SHARPENER**

TYPE: BMS250

No. of manufacturer: .....

Applicable EC Directives: EC Machinery Directive 2006/42/EC  
EC Electromagnetic Compatibility Directive  
2014/30/EC

Used harmonized standards: PN-EN ISO 12100:2010  
PN-EN 60204-1:2018-12  
PN-EN 13849-1:2016-02

Responsible for Technical Documentation: Piotr Adamiec / Engineering Manager  
Wood-Mizer Industries Sp. z o.o.  
62-600 Koło, Nagórna 114, Poland  
Tel. +48 63 26 26 000

Place/Date/Authorized Signature: Koło, 05.11.2012 

Title : Engineering Manager