

Wood-Mizer Re•Sharp™

**(Safety, Operation, Maintenance
& Parts Manual)**

CBN-AC Sharpener rev. A.00



Safety is our #1 concern! Read and understand all safety information and instructions before operating, setting up or maintaining this machine.

December 2000

Form #942

Table of Contents

Section-Page

SECTION 1	SAFETY & GENERAL INFORMATION	1-1
1.1	Electrical Safety.....	1-1
1.2	Blade Handling.....	1-2
1.3	Machine Operation	1-2
1.4	Sharpener Components.....	1-3
1.5	Control Panel Components.....	1-4
SECTION 2	SETUP & OPERATION	2-1
2.1	Blade Support Installation	2-1
2.2	Blade Clamp Adjustment	2-2
2.3	Hook Angle Adjustment.....	2-3
2.4	Sharpener Alignment.....	2-5
2.5	Grinding Wheel Installation	2-7
2.6	Blade Installation.....	2-7
2.7	Face Grind Adjustment.....	2-8
2.8	Depth Grind Adjustment	2-9
2.9	Oil Flow Adjustment	2-11
2.10	Feed Rate Adjustment	2-11
2.11	Blade Rejection	2-11
2.12	Operation Overview	2-12
2.13	Shutoff.....	2-12
SECTION 3	MAINTENANCE	3-1
3.1	Grinding Wheel Replacement	3-1
3.2	Oil Level.....	3-1
3.3	Bearing/Shaft Replacement.....	3-2
SECTION 4	MAINTENANCE & TROUBLESHOOTING	4-1
4.1	Sharpener Maintenance	4-1
4.2	Blade Sharpening Tips	4-2
SECTION 5	ALIGNMENT	5-1
5.1	Roller Bearing Alignment	5-1

Table of Contents

Section-Page

SECTION 6 PARTS

6-1

6.1	How To Use The Parts List	6-1
6.2	Sample Assembly	6-1
6.3	Side Blade Support Arms	6-2
6.4	Stand Assembly	6-3
6.5	Brush.....	6-5
6.6	Rear Blade Support Guides	6-6
6.7	Motor Mount	6-7
6.8	Cam.....	6-9
6.9	Clamp	6-11
6.10	Grinder.....	6-13
6.11	Drip Pan/Pump	6-15
6.12	Control Panel/Box	6-16

SECTION 7 ELECTRICAL INFORMATION

7-1

7.1	Electrical Symbol Diagram, Industrial Sharpener.....	7-1
7.2	Electrical Component List.....	7-2
7.3	Component Layout Diagram	7-2

SECTION 1 SAFETY & GENERAL INFORMATION



This symbol calls your attention to instructions concerning your personal safety. Be sure to observe and follow these instructions. This symbol accompanies a signal word. The word **DANGER** indicates an imminently hazardous situation which, if not avoided, will result in death or serious injury. **WARNING** suggests a potentially hazardous situation which, if not avoided, could result in death or serious injury. **CAUTION** refers to potentially hazardous situations which, if not avoided, may result in minor or moderate injury to persons or equipment. Read all safety instructions before operating this equipment and observe all safety warnings!



Warning stripes are placed on areas where a single decal would be insufficient. To avoid serious injury, keep out of the path of any equipment marked with warning stripes.

Read and observe all safety instructions before operating this equipment! Also read any additional manufacturer's manuals and observe any applicable safety instructions including dangers, warnings, and cautions.

Always be sure that all safety decals are clean and readable. Replace all damaged safety decals to prevent personal injury or damage to the equipment. Contact your local distributor, or call your Customer Service Representative to order more decals.

Always properly dispose of all by-products, including debris, coolant and oil.

Safety instructions are listed in this section by the following operations:

- Electrical Safety
- Blade Handling
- Machine Operation

1.1 Electrical Safety



DANGER! Make sure all electrical installation, service and/or maintenance work is performed by a qualified electrician and is in accordance with applicable electrical codes.

DANGER! HAZARDOUS VOLTAGE can cause shock, burns, or death. SHUT OFF & LOCK OUT POWER before performing service in any area of this machine. DO NOT restore power until all access panels are replaced and secured.



WARNING! Always turn off and disconnect power at control console AND at main supply circuit breaker before performing any service to the machine.

1.2 Blade Handling



WARNING! Always wear gloves and eye protection when handling bandsaw blades. Keep all persons away from area when coiling or carrying a blade.

1.3 Machine Operation



DANGER! Make sure all guards and covers are in place and secured before operating the sharpener. Failure to do so may result in serious injury.

DANGER! Keep all persons away from moving parts when operating this machine. Failure to do so will result in serious injury.

DANGER! Always keep hands away from moving bandsaw blade. Failure to do so will result in serious injury.



WARNING! Always wear eye, ear, respiration, and foot protection when operating this machine. Failure to do so may result in serious injury.

WARNING! Secure all loose clothing and jewelry before operating this machine. Failure to do so may result in serious injury or death.

1.4 Sharpener Components

See Figure 1-1. The major components of the Industrial Sharpener are shown below.

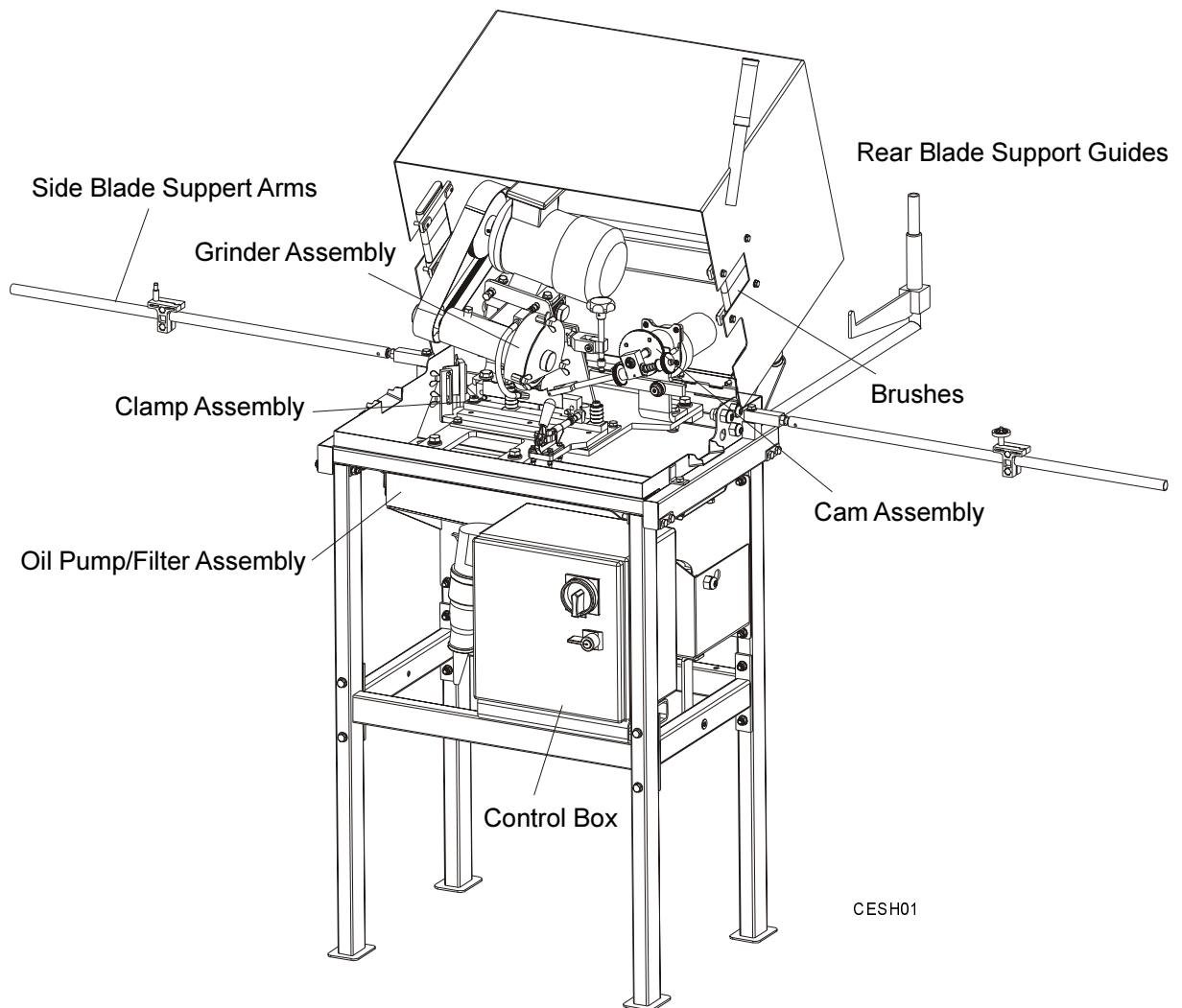

FIG. 1-1

1.5 Control Panel Components

See Figure 1-2. The control panel components and their descriptions are shown below.

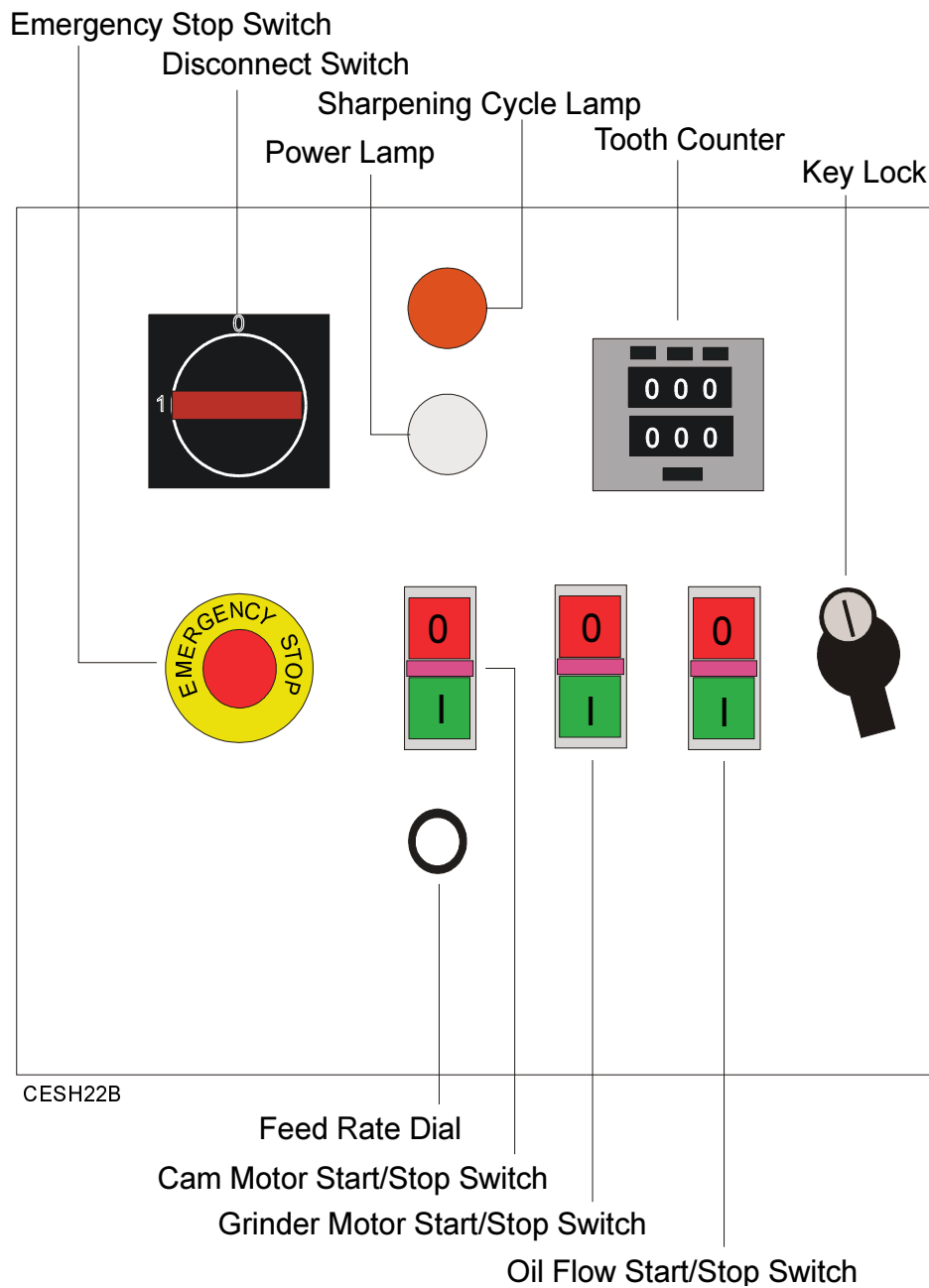

FIG. 1-2

- **Disconnect switch**

Disconnects/connects power to equipment.

Turn switch to the "0", or vertical, position to lock out all electrical power during service or when equipment is not in use. NOTE: The Disconnect Switch must be in the "0" position before the control box door can be opened.

To reconnect power to equipment, turn switch to the "1", or horizontal, position.

- **Sharpening Cycle Lamp**

Lights up when the blade has been sharpened completely.

- **Feed Rate Dial**

Controls cam speed.

Rotate dial as necessary to increase or decrease cam speed.

- **Tooth counter**

Sets/keeps track of number of teeth to be sharpened

The upper dial controls the number of teeth to be sharpened. To set, press the button above the appropriate number until the dial shows the total number of teeth on the blade to be sharpened.

The lower dial automatically keeps track of the number of teeth which have been sharpened. After reaching the number set by the upper dial, the lower dial must be reset before the sharpener can be operated again. To reset, push the reset button in and release.

- **Emergency Stop Switch**

Shuts off all machine operations.

To shut off all machine operations, press this switch. NOTE: After being activated, the Emergency Stop Switch must be reset before the sharpener can be operated again. To reset, rotate the switch counterclockwise and release.

- **Oil Flow Start/Stop Switch**

Starts/Stops coolant pump motor

- **Grinder Motor Start/Stop Switch**

Starts/Stops grinder motor

- **Cam Motor Start/Stop Switches**

Press the Cam Motor Start Switch to clamp the blade in place and start the cam motor. NOTE: Place the Feed Rate Dial in the "0" position before starting the cam motor.

Press the Cam Motor Stop Switch to turn the cam motor off and unclamp the blade.

SECTION 2 SETUP & OPERATION

2.1 Blade Support Installation

The sharpener includes two blade support arms with guide assemblies.

To install the support arms, lubricate the threaded ends of the arms with grease. Insert one arm into the threaded holes on each side of the sharpener.

1. Each guide assembly includes a blade support with post, a blade support without post, two bolts, a self-locking nut, and a wing nut.

See Figure 2-1. To install the guide assemblies, join one of the guide assemblies around the end of the left blade support arm. Face the post outward as shown. Bolt from the hexed side of the guide assembly (these hex-shaped holes will keep the bolts from turning once in place). Secure the top bolt with a self-locking nut. Secure the bottom bolt with a wing nut.

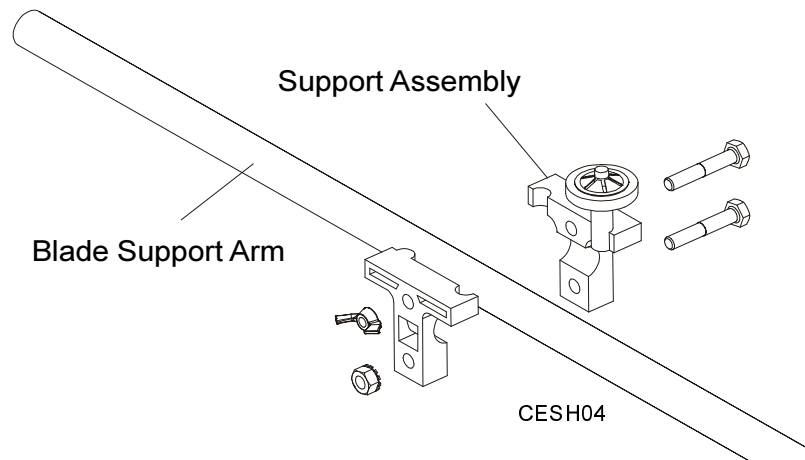

2. Assemble the remaining one guide assembly to the right blade support arm, posts facing outward.
3. Tilt the guides on the left blade support arm slightly backward, toward the rear of the sharpener. Tilt the guides on the right support arm slightly forward, toward the front of the sharpener.

2.2 Blade Clamp Adjustment

The adjustable blade clamp allows you to sharpen 1", 1 1/4", 1 1/2", 1 3/4", and 2" blades.

See Figure 2-2. The blade rests on two height adjustment pins. The pins insert into any of the rear clamp block's five sets of holes.

Place the blade height adjustment pins in the top set of holes to sharpen 1" blades, the next set to sharpen 1 1/4" blades, and so on.

To change pin location, remove the set screw from each side of the rear clamp block. Remove the pins from one set of holes and reinstall to desired set of holes. Reinstall the set screws to the appropriate holes in the sides of the block and tighten to secure the pins in place.

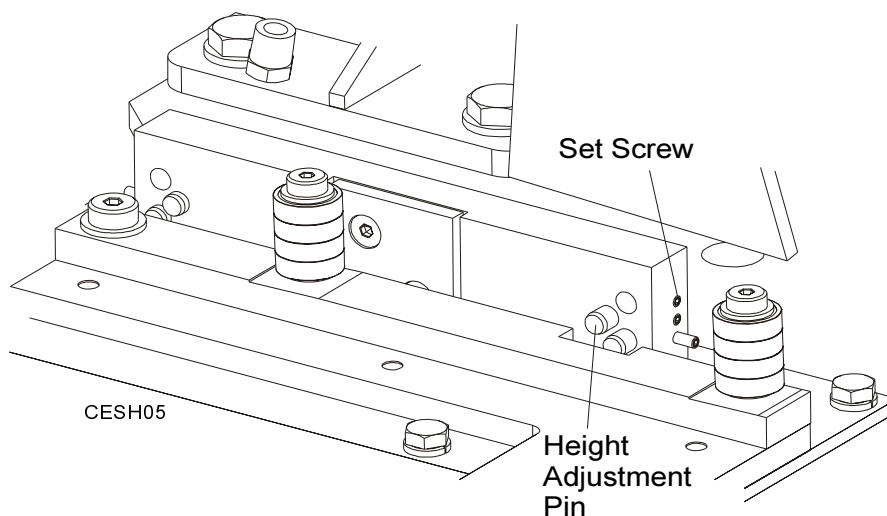

FIG. 2-2

2.3 Hook Angle Adjustment

An angled template, which includes angle for 15 degrees, is provided to check hook angle.

Note: Refer to the Wood-Mizer Blade Handbook for recommended hook angle specifications for your sawing application.

See Figure 2-3. To adjust sharpener head hook angle, set the straight part of the provided template on the clamping fixture. Loosen the depth adjustment and/or the depth stop knob until the sharpener head rests on the template.

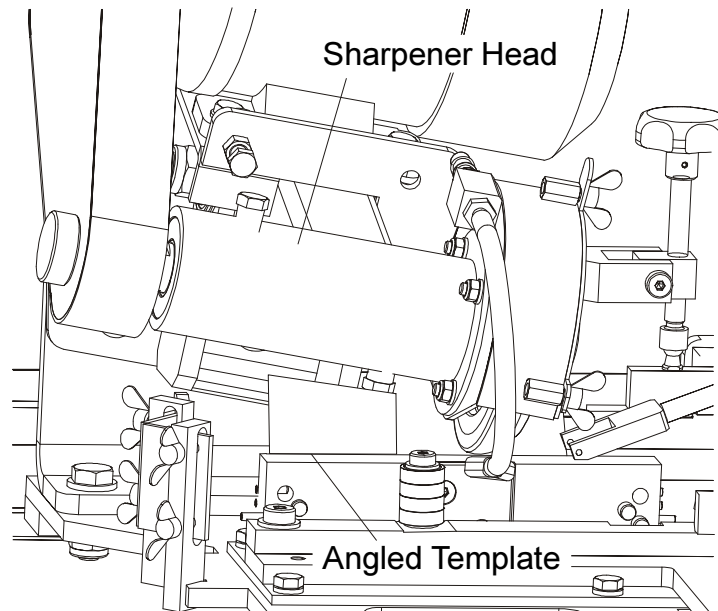

FIG. 2-3

2

Setup & Operation

Hook Angle Adjustment

See **Figure 2-4**. Next, loosen the sharpener head mounting bolt and nut in the motor mounting bracket. Loosen stop bolt and its jam nut. Tip the sharpener head until you reach the desired angle. Hold the sharpener head in place while retightening the sharpener head mounting bolt and nut. Tighten the stop bolt and secure it with the jam nut.

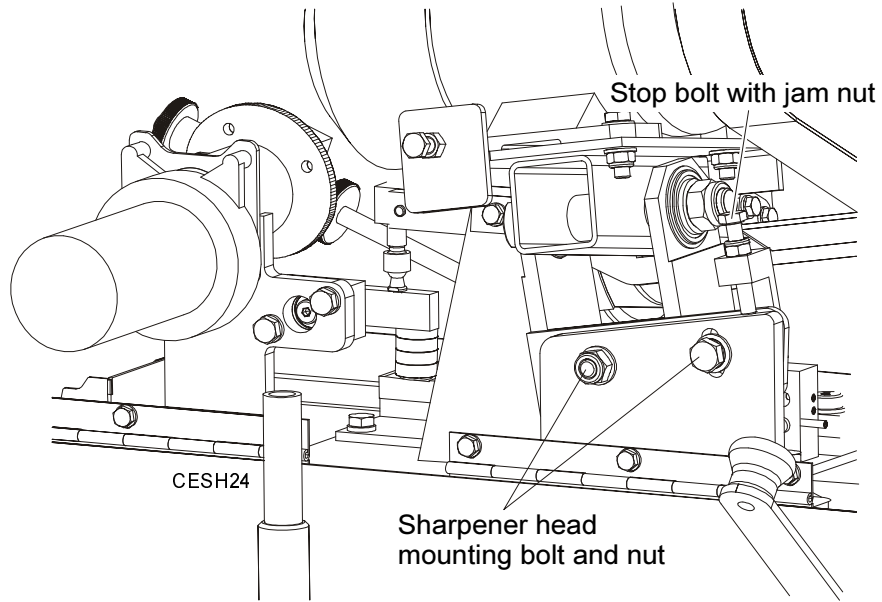

FIG. 2-4

2.4 Sharpener Alignment

Use the Semi-industrial sharpener alignment tool as necessary to achieve accurate alignment between the blade clamp and the grinding wheel.



IMPORTANT! Do not attempt to adjust the tool gauge points. They have been pre-calibrated at the factory to ensure accurate alignment results.

IMPORTANT! The grinding wheel must be 4" in diameter or larger. Do not align the sharpener if the grinding wheel is less than 4".

1. Make sure the grinder motor is OFF. Cycle the cam until the grinding wheel is at the tip of the tooth (about to begin face grind).
2. Remove the plate with clamp assembly.
3. Remove the grinding wheel cover and sharpener arbor nut. Remove the grinding wheel.
4. Install the alignment tool to the grinder motor shaft as shown.

See Figure 2-5. Position the tool so all three gauge points are in line with the front clamp plate. Secure the tool in position with the sharpener arbor nut.

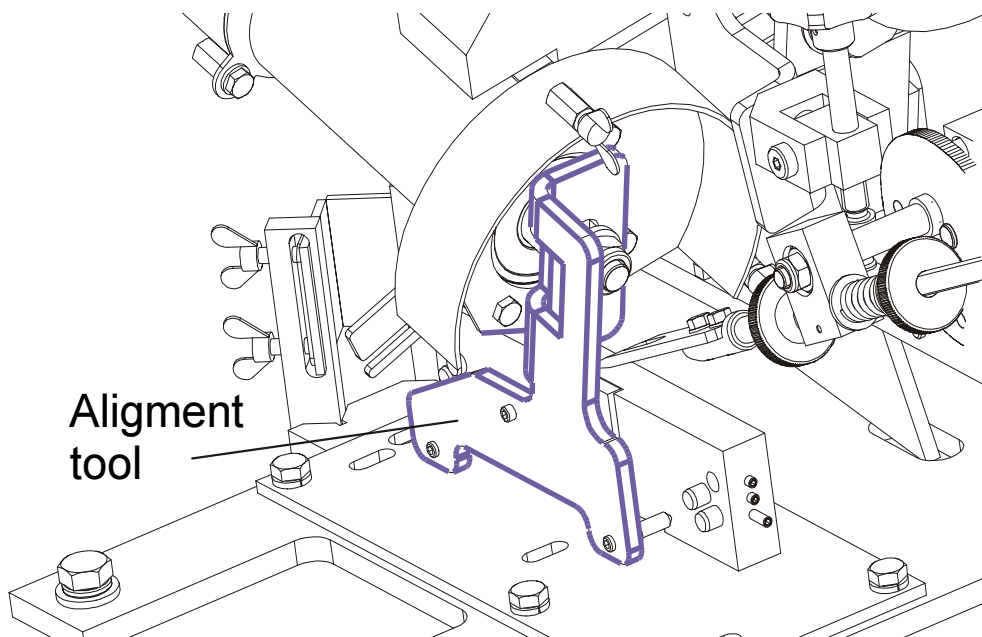

FIG. 2-5

2 Setup & Operation

Sharpener Alignment

5. Install 12 flat washers to the motor shaft. Secure the alignment tool and spacer washers in position with the sharpener arbor nut.

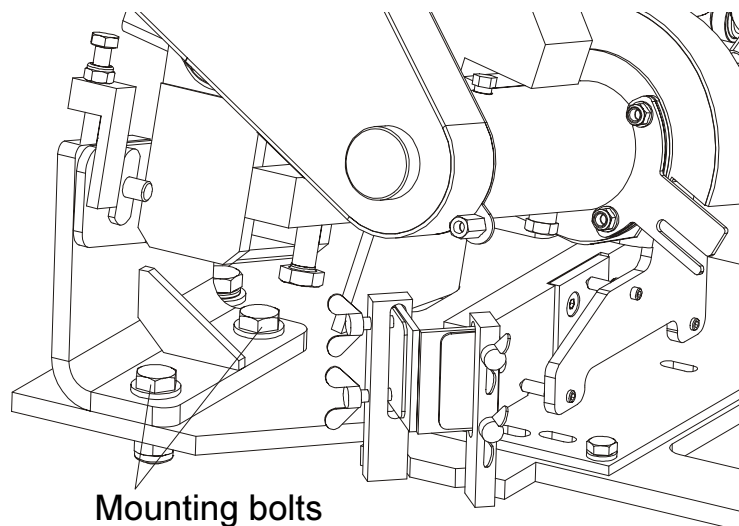

FIG. 2-5A

6. Use a 3/4" wrench to loosen the mounting bolts.
7. Position the sharpener head so the front clamp plate touches all three tool gauge points. Secure in position by tightening the bracket mounting bolts.

2.5 Grinding Wheel Installation

Use a Wood-Mizer approved grinding wheel. To install:

1. Push the START button on the control box and turn the FEED RATE dial up to rotate the cam.
2. Rotate the cam until the sharpener head is at its highest setting. Turn the FEED RATE all the way down and push the STOP button.
3. Remove the grinding wheel cover.
4. Remove the nut and washer from the motor shaft.
5. Slide a grinding wheel onto the shaft.
6. Reinstall the washer and nut and hand tighten. Reinstall the cover.



DANGER! Make sure all guards and covers are in place and secured before operating the wash station. Failure to do so may result in serious injury.

7. After installing the grinding wheel, hold the sharpener head up with your hand and turn the back/depth grind knob until you can lower the head and the grinding wheel will not contact the blade. Carefully lower the sharpener head.

2.6 Blade Installation

1. Uncoil a blade and position inside the back support guides and between the guide posts of the appropriate side guide assemblies.
2. Insert the blade between the blade wipers and the blade clamp.
3. Make any final adjustments to the support arms and guide assemblies to ensure the blade band rests evenly on both the right and left blade clamp assembly pins. Make sure the blade does not touch the bottom of either side guide assembly.

Make sure the guide assemblies lean slightly in the direction the blade travels through them.

2.7 Face Grind Adjustment

As you operate the sharpener, the cam will rotate causing the index arm to contact a tooth and push it to a position under the grinding wheel. The index arm can be adjusted to leave the tooth closer to or further from the grinding wheel so the tooth face is ground lighter or heavier.

1. Before adjusting the face grind, make sure the cam and grinder motors are off, the feed rate dial is set at "0" and the Sharpener head is raised.
2. Back the depth stop knob out.
3. Turn on the cam motor and grinder motor. Slowly increase the FEED RATE until the next tooth is underneath the grinding wheel.
4. Lower the Sharpener head and check to make sure the grinding wheel lightly contacts the entire face of the tooth all the way up to the tip.

See Figure 2-6. If the face grind is too light, turn the face grind adjustment knob out away from the other knob. If the face grind is too heavy, turn the adjustment knob in toward the other knob.

5. Recheck the face grind on the next tooth and adjust as needed.

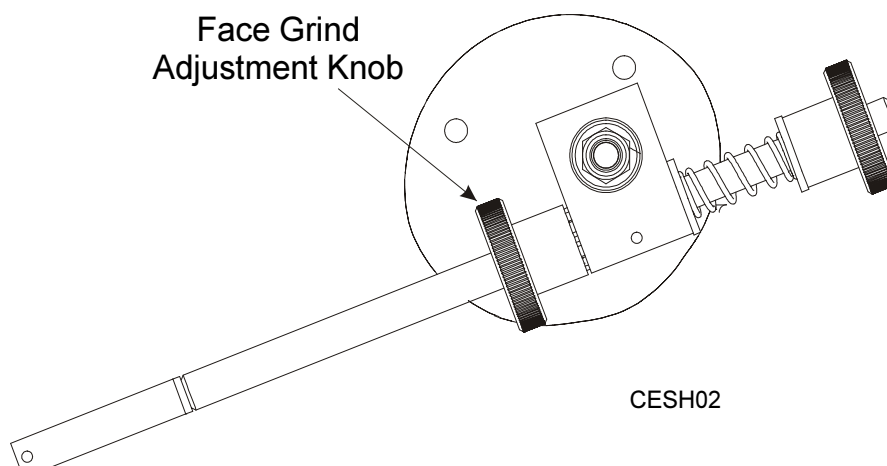

FIG. 2-6

2.8 Depth Grind Adjustment

Tooth height is determined by how much material is removed from the gullet of the blade. The depth/back grind knob controls how far the grinding head comes down and therefore controls the gullet grind.

1. With the feed rate at "0", turn on the cam and grinder motors.
2. Turn up the feed rate and check the depth grind. The grinding wheel should lightly touch the gullet of the blade and you should see clean metal across the entire gullet of the sharpened tooth.
3. If adjustment is needed, turn the depth stop knob. Turn the knob in to lower the head, out to raise the head.

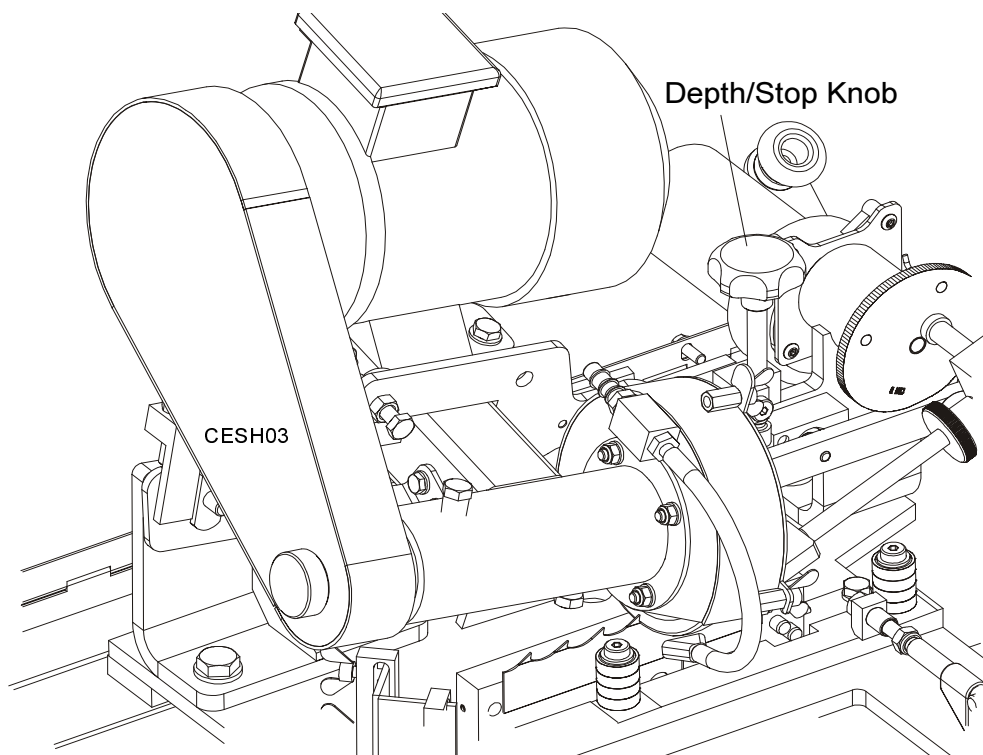

FIG. 2-6

4. Recheck the depth grind.
5. Check the depth grind two to three times during the blade sharpening. Make sure you see clean metal across the entire gullet of sharpened teeth each time. If you do not see clean metal, stop the sharpener and adjust the depth grind as necessary.

IMPORTANT! After any adjustment, always restart the blade and sharpen in its entirety to ensure symmetry.

NOTE: Depth grind may be affected as the grinding wheel passes over blade welds.

2.9 Oil Flow Adjustment

To start the oil flow, press the oil flow start switch.

2.10 Feed Rate Adjustment

The Feed Rate Dial controls cam speed. During the sharpening cycle, adjust cam speed to have as fast of a feed rate as possible without "burning" the blade.

NOTE: All machines should be adjusted by maintenance to a maximum speed of 60 revolutions per minute. [See Section 4.2.](#)

2.11 Blade Rejection

Sometimes blades cannot be resharpened. Reasons to reject blades for resharpening include:

- the blade is coil set (the blade is over-stressed and will fold on itself),
- the blade is missing 2 or 3 teeth or more in a row,
- the blade band has been twisted,
- the blade band is too low for the grinder (the blade has been sharpened too many times/too much material has already been ground from the blade),
- the blade has no set on one of its sides,
- severe rust is present,
- or the blade has tooth spacing uncommon to Wood-Mizer blades (i.e., a competitor's blade).

2.12 Operation Overview

Use the following steps to guide you through sharpener operation.

1. Adjust the blade clamp for the blade you will be sharpening by installing the blade height pins in the proper holes.
2. Install a grinding wheel if necessary, then install the blade.
3. Set the upper dial on the tooth counter for the number of teeth in the blade you will be sharpening. Be sure to close the lower dial cover when done.
4. Adjust face grind and depth grind.
5. Push the tooth counter reset button to start the upper dial at "0".
6. Turn on the oil flow.
7. Increase the feed rate to a moderate speed. How fast you can grind will be determined by how much material you are removing from the blade. If a heavy grind is required, it is best to go around the blade lightly twice rather than try to grind heavily once.
8. Check the depth grind two to three times during the blade sharpening. Adjust as necessary.

IMPORTANT! After any adjustment, always restart the blade and sharpen in its entirety to ensure symmetry.

2.13 Shutoff

The sharpener will automatically shutoff when blade has been entirely sharpened.

Inspect the blade. Repeat sharpening process if necessary. Blades with a bad profile or those which are badly in need of sharpening may have to be ground more than once.

SECTION 3 MAINTENANCE

3.1 Grinding Wheel Replacement

Check the grinding wheel often and change as necessary. Wheels approved for use with the industrial sharpener are available from Wood-Mizer.

The grinding wheel should be in good condition. Replace if worn, the edges look shiny, and/or the wheel is "burning" the blades. **NOTE:** The grinding wheels have a CBN (Cubic Boron Nitride) coating. If this is not worn through and there is no damage to the wheels, the wheels can be replated approximately three to four times.

1. To replace, shut down and lock out all power to the machine.
2. Remove the grinding wheel cover.
3. Remove the grinding wheel nut, washer plate and grinding wheel.
4. Install the new grinding wheel. Reinstall the washer plate and nut.
5. Reinstall the grinding wheel cover.

3.2 Oil Level

Periodically check the oil level and refill with oil as necessary. The oil level should be kept between 4.5 and 5 litres. Use only Wood-Mizer approved grinding oil.

Filter the oil to remove metal shavings before reusing.

3.3 Bearing/Shaft Replacement

Check the bearings periodically for wear and replace as necessary. To replace:

1. Shut off and lock out all power to the machine.
2. From the front of the machine, remove the front guard cover and grinding wheel.

See Figure 3-1.

3. From the rear of the machine, remove the belt guard weldment and belt.

Remove the rear nut and washer.

Remove the lower gearbelt pulley.

Remove the both oil seal bearings and rear ring.

4. Remove the grinder shaft. (Use a brass or rubber mallet to gently tap the shaft towards the front of the machine until the shaft can be removed.)
5. Remove the front roller bearing.
6. Remove the rear roller bearing from the shaft housing.
7. Clean the grinder shaft.
8. Install the new front roller bearing to the grinder shaft. Secure the front roller bearing with the front ring.

Install the new rear roller bearing to the grinder shaft.

Reinstall the front rings and oil seal bearing.

Reinstall the grinder shaft to the grinder shaft. Secure the rear roller bearing with the rear ring.

Reinstall both oil seal bearings.

Reinstall the gearbelt pulley and rear washer and nut

Reinstall the belt and belt guard weldment.

9. Once bearing replacement is complete, be sure to check head alignment.

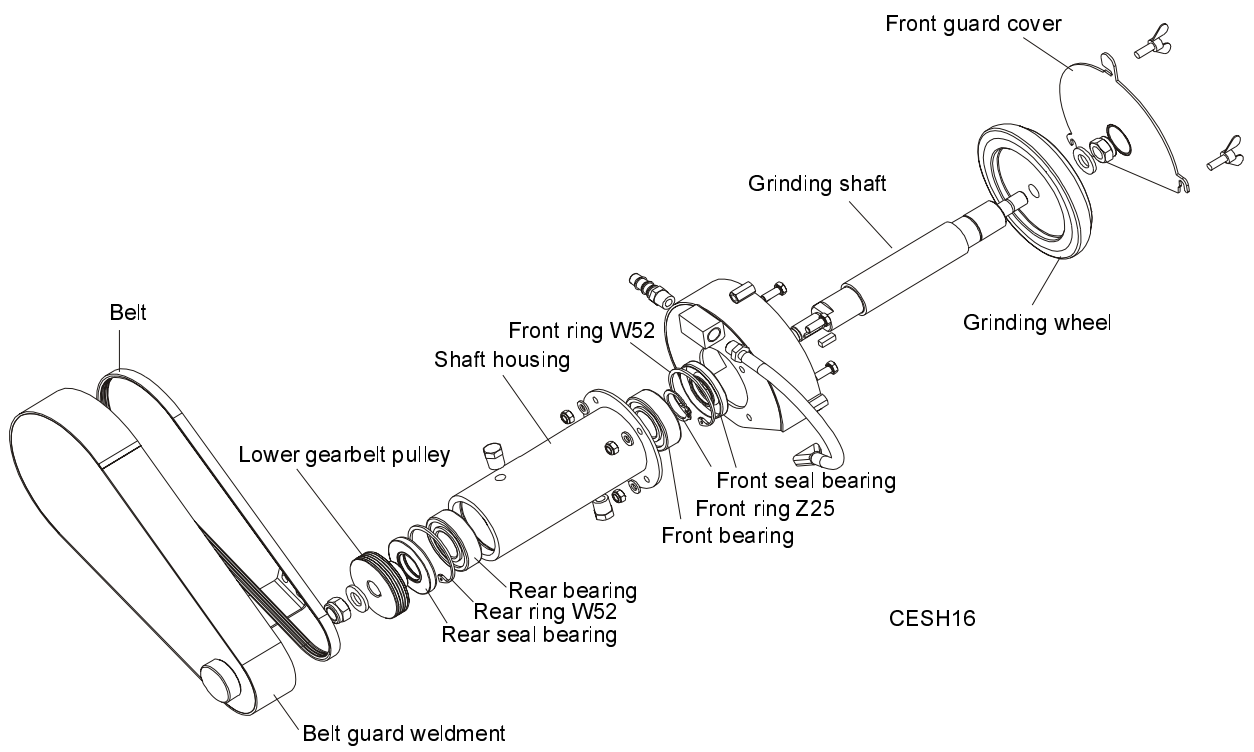

FIG. 3-1

SECTION 4 MAINTENANCE & TROUBLESHOOTING

4.1 Sharpener Maintenance

- Wipe the sharpener dry after each day's use.
- Keep clean of dirt, rust, and metal filings.
- Clean out regularly any buildup that might cause it to not clamp the blade firmly. To do so, remove the clamp arm and wear clamp plate. When replacing clamp, replace it flat against the stop block.
- Clean sediment from the oil pan and filter magnets as needed.

4.2 Blade Sharpening Tips

This section covers some of the common problem areas of blade sharpening.

Before removing from the saw, clean the blade by running the waterlube on the blade for 15 seconds. This will remove most of the sap buildup that would otherwise have to be scraped off when it dries. Wipe with a clean dry rag.

Make sure the flow of oil through the oiler assembly is strong.

Sharpen the blade when it first shows signs of dullness. If the blade is extremely dull, due to hitting a rock or some form of foreign matter, sharpen the blade twice lightly, instead of trying to remove too much in one grind. Grinding too much material at once may cause the circuit breaker in the control box to kick out. If this happens, wait 15 seconds. Then turn it on (push circuit breaker down).

SECTION 5 ALIGNMENT

Align the sharpener monthly to ensure quality performance. Also realign the sharpener as necessary (i.e., after the grinding wheel has been impacted by the index pawl).

5.1 Roller Bearing Alignment

1. Raise the sharpener head.
2. Install a blade.
3. Check to see that each of the four clamp roller bearings are touching the blade. If they are not, loosen the three set screws on the blade clamp mounting plate (see figure 5-1). Adjust the set screws to move the front of the plate as necessary to align the clamp roller bearings to the blade.
4. Retighten the set screws to secure them in place.

See Figure 5-1.

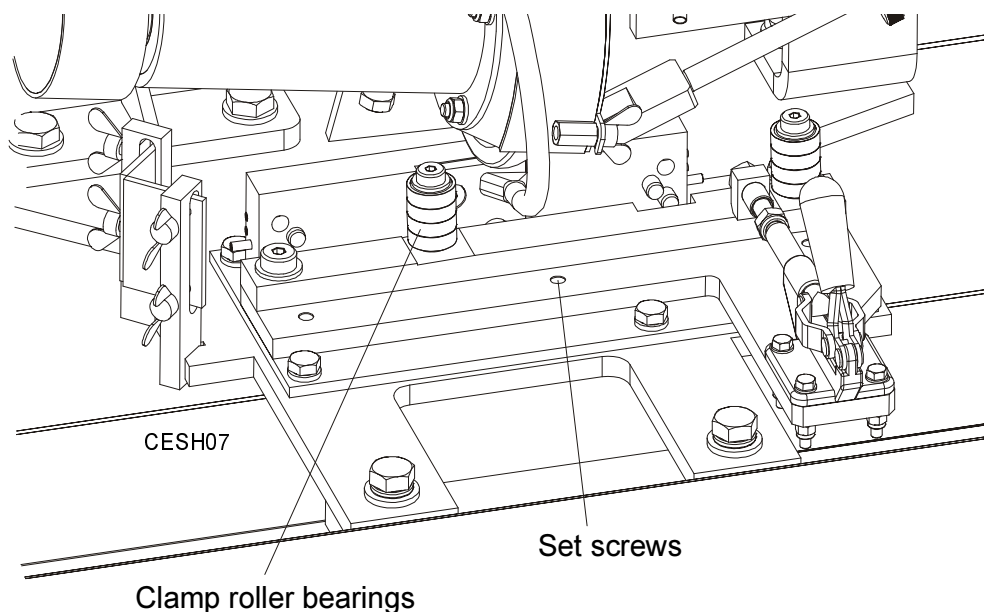

FIG. 5-1

SECTION 6 PARTS

6.1 How To Use The Parts List

- Use the table of contents or index to locate the assembly that contains the part you need.
- Go to the appropriate section and locate the part in the illustration.
- Use the number pointing to the part to locate the correct part number and description in the table.
- Parts shown indented under another part are included with that part.
- Parts marked with a diamond (◆) are only available in the assembly listed above the part.

See the sample table below. Sample Part #A01111 includes part F02222-2 and subassembly A03333. Subassembly A03333 includes part S04444-4 and subassembly K05555. The diamond (◆) indicates that S04444-4 is not available except in subassembly A03333. Subassembly K05555 includes parts M06666 and F07777-77. The diamond (◆) indicates M06666 is not available except in subassembly K05555.

6.2 Sample Assembly				
REF	DESCRIPTION (◆ Indicates Parts Available In Assemblies Only)	PART #	QTY.	
	SAMPLE ASSEMBLY, COMPLETE (INCLUDES ALL INDENTED PARTS BELOW)	A01111	1	
1	Sample Part	F02222-22	1	
	Sample Subassembly (Includes All Indented Parts Below)	A03333	1	
2	Sample Part (◆ Indicates Part Is Only Available With A03333)	S04444-4	1	◆
	Sample Subassembly (Includes All Indented Parts Below)	K05555	1	
3	Sample Part (◆ Indicates Part Is Only Available With K05555)	M06666	2	◆
4	Sample Part	F07777-77	1	

To Order Parts:

- From Europe call our European Headquarters and Manufacturing Facility in Kolo, Poland at **+48-63-2610233**. From the continental U.S., call our toll-free Parts hotline at **1-800-525-8100**. Have your customer number, vehicle identification number, and part numbers ready when you call.
- From other international locations, contact the Wood-Mizer distributor in your area for parts.

6.3 Side Blade Support Arms

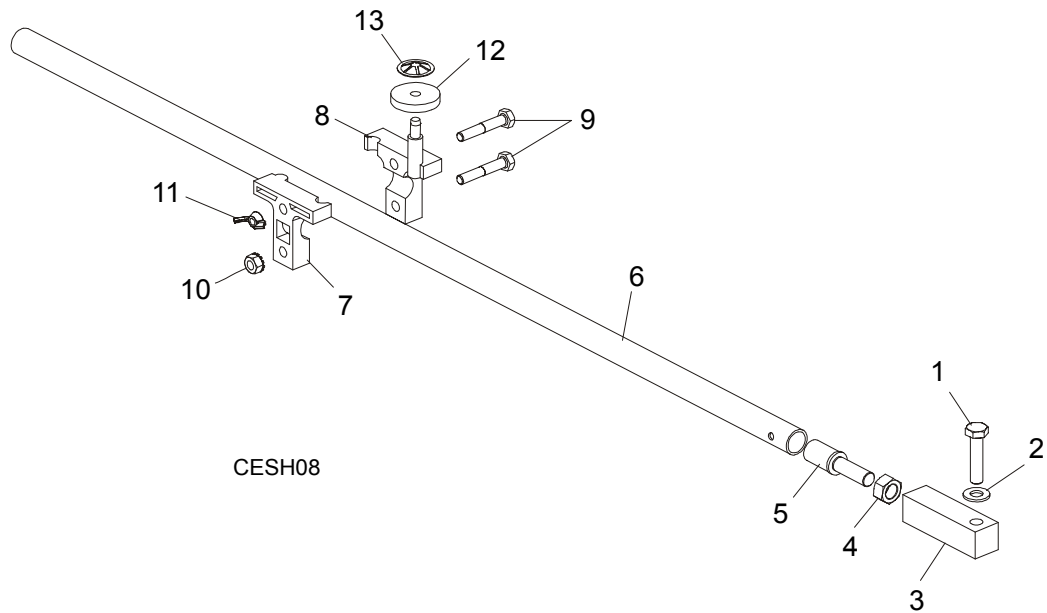

REF	DESCRIPTION (◆ Indicates Parts Available In Assemblies Only)	PART #	QTY.
1	BOLT, M8 X 35 HEX HEAD	F81002-13	2
2	WASHER, 8.4 FLAT	F81054-1	2
3	ARM, BLADE MOUNTING	087828	2
4	NUT, M10-8 HEX	F81033-3	2
	BLADE SUPPORT ASSEMBLY, SHORT	087518-1	3
5	Plug, Tube Support	087506	1
6	Tube, Short Support	087514	1
	SUPPORT ASSY, BLADE REPLACEMENT	A10617	1
7	Guide w/Post Blade Support	S10611	2
8	Guide w/o Post Blade Support	S10612	2
9	Bolt, 1/4-20 x 1 1/2" Hex Head Grade 2	F05005-5	2
10	Nut, 1/4-20 Self-Locking	F05010-9	1
11	Nut, 1/4-20 Wing	F05010-13	1
12	WHEEL, BLADE GUIDE	S10539	1
13	NUT, 1/4"	P10614	1

6.4 Stand Assembly

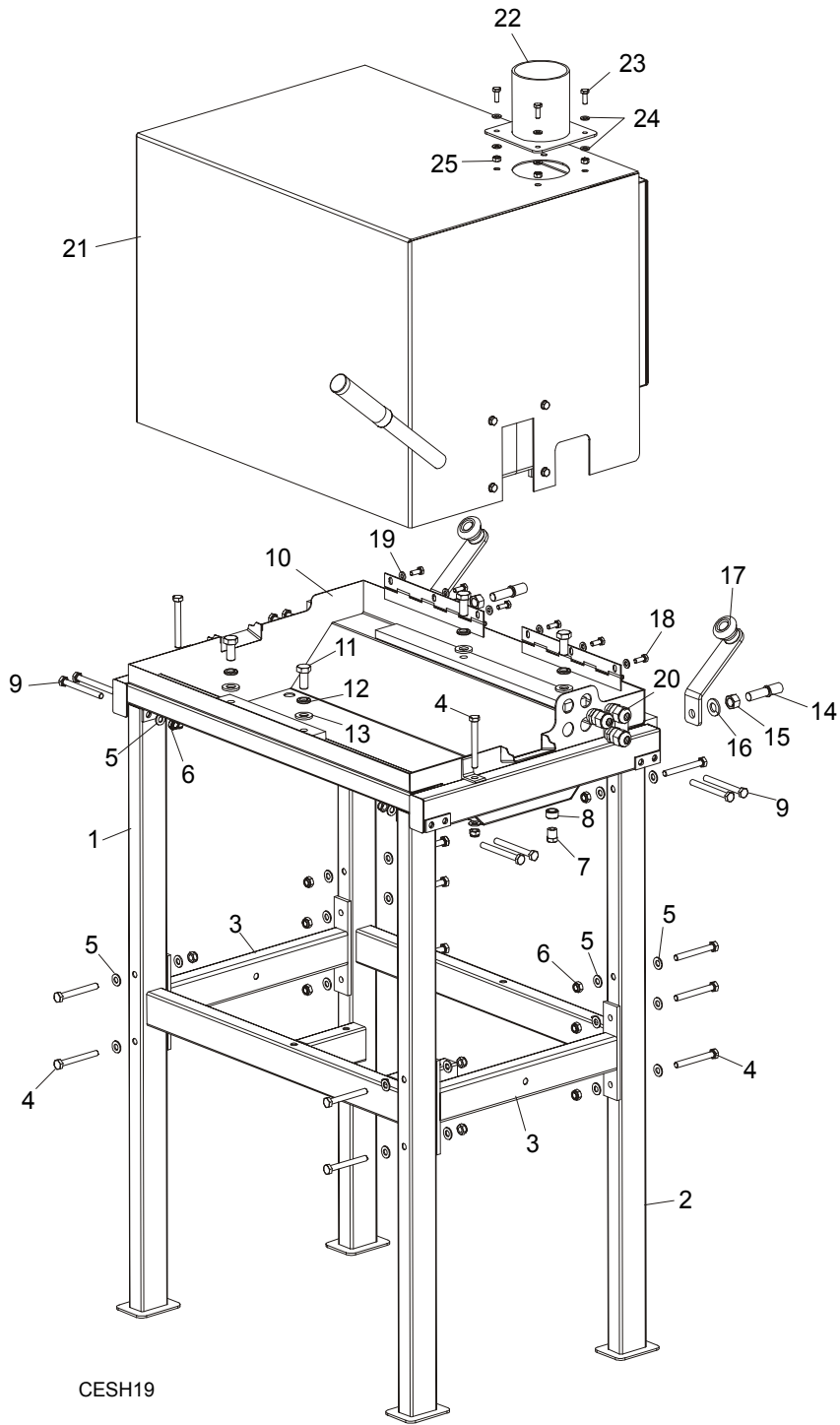

CESH19

REF	DESCRIPTION (◆ Indicates Parts Available In Assemblies Only)	PART #	QTY.
	STAND ASSEMBLY	N/A	1

6

Parts
Stand Assembly

1	Stand Weldment, Sharpener Front	087578-1	1	
2	Stand Weldment, Sharpener Back	087595-1	1	
3	Stand Weldment, Sharpener Side	087800	2	
4	Bolt, M8 X 70-8.8 Hex Head	F81002-71	14	
5	Washer, 8.4 Flat	F81054-1	32	
6	Nut, M8-8 Hex Nylon lock	F81032-2	22	
7	Plug, 1/4"	087605	1	
8	Seal, Plug	087609	2	
9	Bolt, M8 X 80-8-8 Hex Head	F81002-18	8	
10	Pan Weldment, Drain	087569-1	1	
11	Bolt, M12 X 25-8.8 Hex Head	F81004-31	4	
12	Washer, Z12.2 Split Lock	F81056-2	4	
13	Washer, 13 Flat	F81056-1	4	
14	Plug, Pipe Support	087585	2	
15	Nut, M12-8 Hex	F81034-1	2	
16	Washer, 13 Flat	F81056-1	2	
17	Bracket, Cover Weldment	087824	2	
18	Bolt, M6 X 16-8-.8 Hex Head	F81001-15	6	
19	Washer, 6.4 Flat	F81053-1	6	
20	Seal, Gland	085388	3	
	Sharpener Head Cover Assembly	087602	1	
21	Cover Weldment, Head	087601-1	1	
22	Housing, Cover	087974	1	
23	Bolt, M6 X 16-8-.8 Hex Head	F81001-15	4	
24	Washer, 6.4 Flat	F81053-1	4	
25	Nut, M6-8 Hex	F81031-1	4	

6.5 Brush

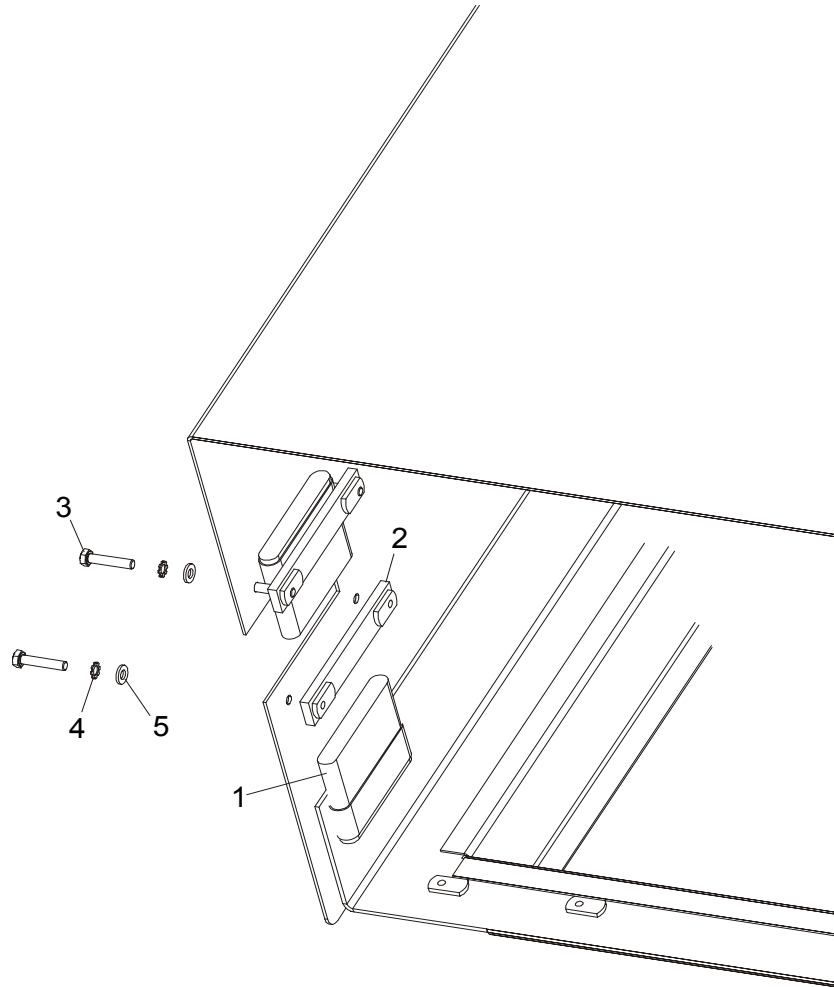

CESH12

REF	DESCRIPTION (◆ Indicates Parts Available In Assemblies Only)	PART #	QTY.	
1	BRUSH, 2" FLAT CHIP	087603	4	
2	BAR, BRUSH MOUNT	087606-1	4	
3	SCREW, M6 X 30-5.8 HEX HEAD	F81001-13	8	
4	WASHER, 6.4 EXTERNAL RING	F81053-2	8	
5	WASHER, 6.4 FLAT	F81053-1	8	

6.6 Rear Blade Support Guides

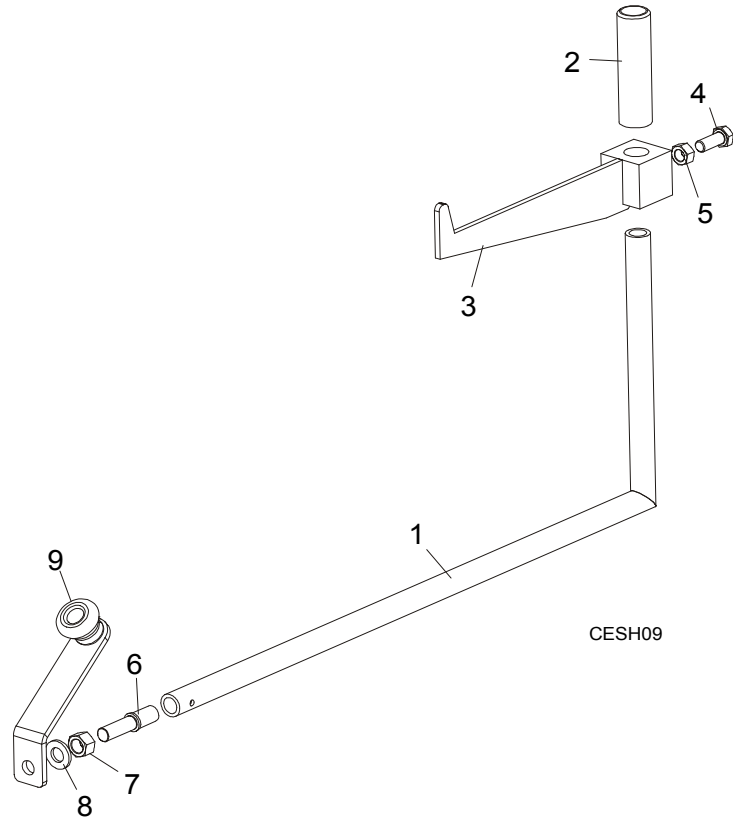

REF	DESCRIPTION (◆ Indicates Parts Available In Assemblies Only)	PART #	QTY.
	REST ASSEMBLY, BLADE	N/A	1
1	Pipe, Support	087584-1	1
2	Pipe, Blade Wear	087590	1
3	Rest Weldment, Blade	087589-1	1
4	Bolt, M10 X 25-8.8 Hex Head	F81003-11	1
5	Nut, M10-8 Hex	F81033-3	1
6	Plug, Pipe Support	087585	1
7	Nut, M12-8 Hex	F81034-1	1
8	Washer, 13 Flat	F81056-1	1
9	Support, Head Cover	087824	1

6.7 Motor Mount

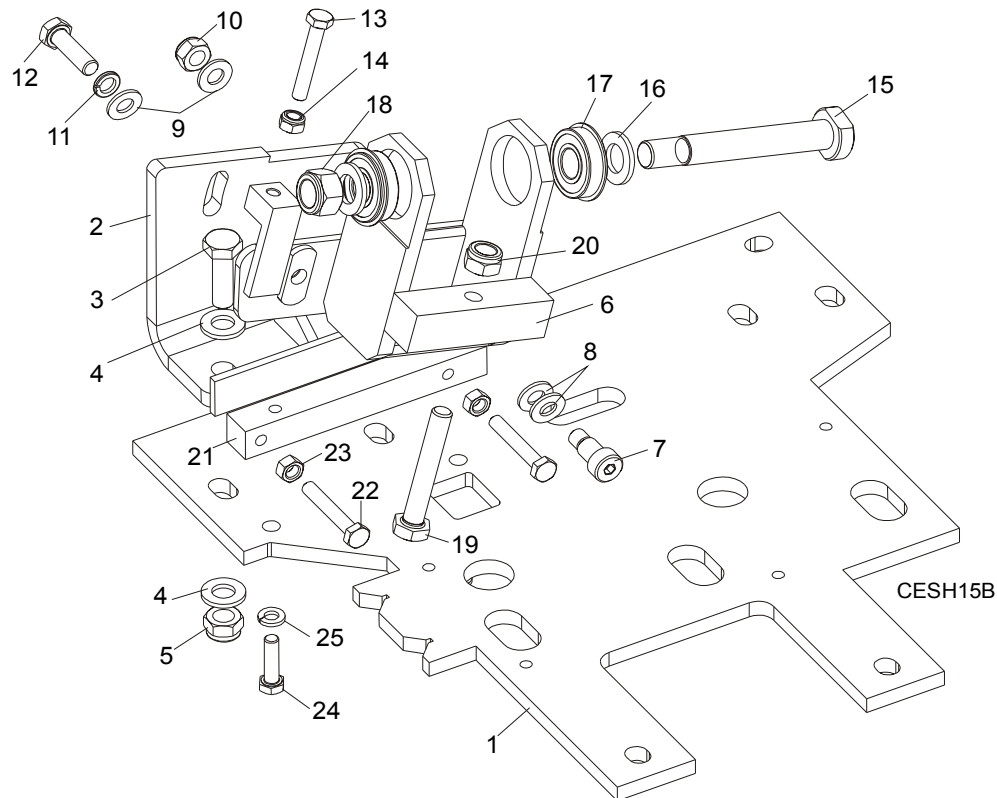

REF	DESCRIPTION (◆ Indicates Parts Available In Assemblies Only)	PART #	QTY.
1	PLATE, BASE	087459	1
2	SHARPENER HEAD MOUNT PTD	087566-1	1
3	BOLT, M12 X 40-8.8 HEX HEAD	F81004-4	2
4	WASHER, 13 FLAT	F81056-1	4
5	NUT, M12-8 HEX HEAD	F81034-2	2
6	MOUNT WELDEMENT, MOTOR	087707-1	1
7	BOLT, SOCKET HEAD	F81003-64	1
8	WASHER, 13 FLAT	F81056-1	2
9	WASHER, 10.5 FLAT	F81055-1	2
10	NUT, M10-8 HEX HEAD	F81033-1	1
11	WASHER, 10.2 SPLIT LOCK	F81055-2	1
12	BOLT, M10 X 20-5.8 HEX HEAD	F81003-1	1
13	BOLT, M8 X 40 HEX HEAD	F81002-19	1
14	NUT, M8-8 HEX NYLON LOCK	F81032-2	1
15	BOLT, MOTOR MOUNT	086404	4
16	WASHER, 17 FLAT	F81058-1	2
17	BEARING, 6203-2RS W/RING	086395	2
18	NUT, M16-8 HEX NYLON LOCK	F81036-2	1

6**Parts**
Motor Mount

19	BOLT, M12X75-8.8-ZINC, HEX HEAD	F81004-10	1	
20	NUT, M12-8 ZINC, NYLON LOCK, HEX HEAD	F81034-2	1	
21	SHARPENER HEAD ADJUSTMENT BLOCK	089600-1	1	
22	BOLT, M8X50-8.8-ZINC, HEX HEAD	F81002-19	2	
23	NUT, M8-8-B-ZINC, HEX HEAD	F81032-1	2	
24	BOLT M8X30-8.8-B-ZINC, HEX HEAD	F81002-7	2	
25	WASHER, 8,2 ZINC, SPLIT LOCK	F81054-4	2	

6.8 Cam

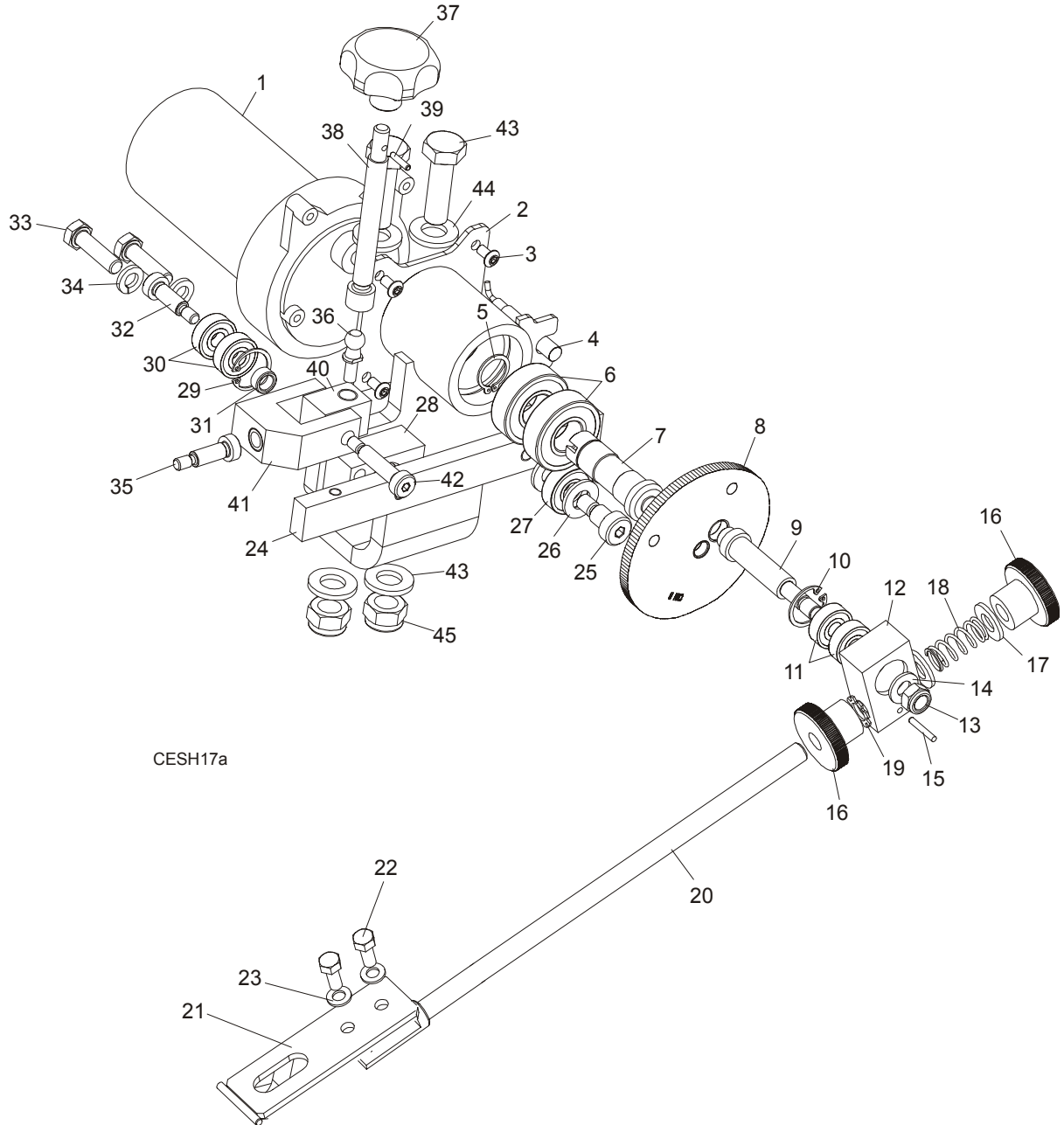

CESH17a

REF	DESCRIPTION (◆ Indicates Parts Available In Assemblies Only)	PART #	QTY.
	INDEXER ASSEMBLY	N/A	1
	Cam Assembly	087369	1
1	Motor, Cam	P09698-1	1
2	Index Motor Mount	087371	1
3	Screw, Motor Mount	F05004-56	4

4	Sensor, Tooth Counter	087709	1	
5	Ring, Z17 Retaining	F81090-21	1	
6	Bearing, 6203-2RS	086114	2	
7	Shaft, Index Motor	087366	1	
8	Cam, Index Heat Treated	010741	1	
9	Shaft, Index Cam	087372	1	
10	Ring, W22 Retaining	F81090-7	1	
11	Bearing, 608-2RS Roller	086197	2	
12	Block, Index	087373	1	
13	Nut, M8-8 Hex Nylon Lock	F81032-2	1	
14	Washer, 8.4 Flat	F81054-1	1	
15	Pin, 6 X 20 Roll	F81048-2	1	
16	Knob, Push Pawl	087375	1	
17	Washer, 10.5 Flat	F81055-1	2	
18	Spring	087376	1	
19	Washer, 10.5 External Ring	F81055-3	1	
20	Pawl Weldment, Blade Index	087374	1	
21	Sharpener Blade Follower - zink	088602-1	1	
22	Bolt M5x12-5.8-Fe/Zn5 PN-M/82105	F81000-5	2	
23	Washer 5,3 Fe/Zn5 PN-M/82005	F81052-1	2	
	Block Assembly	087472	1	
24	Block, Cam	087470-1	1	
25	Bolt, M8 X 12-12.9 Socket Head	F81003-62	1	
26	Washer, 10.5 Flat	F81055-1	2	
27	Bearing, 608-2RS Roller	087471	1	
28	Block, Bearing Mounting	087481-1	1	
29	Ring, W22 Retaining	F81090-7	1	
30	Bearing, 608-2RS	086197	2	
31	Spacer, Index Cam	088260	1	
32	Bolt, 8/M6 X 20 12.9 Socket Head	F81001-25	1	
33	Bolt, M8 X 30-5.8 Hex Head	F81002-2	2	
34	Washer, 8.2 Split Lock	F81054-4	2	
35	Bolt, 8/M6 X 20 12.9 Socket Head	F81001-25	1	
36	Bolt, 10/M6 Pivot Head	087476	1	
	Depth Knob Assmebly	087482	1	
37	Knob, Index Cam	087485	1	
38	Rod, Index Cam	087484	1	
39	Pin, 3 X 14 Roll	F81044-4	1	
40	Block, Small Index Cam Rod Mounting	087481-1	1	
41	Block, Big Index Cam Rod Mounting	087483-1	1	
42	Bolt, 8/M6 X 30-12.9 Socket Head	F81001-18	1	
43	Bolt, M12 X 40-8.8 Hex Head	F81004-4	2	
44	Washer, 13 Flat	F81056-1	2	
45	Nut, M12-8 Hex	F81034-2	2	

6.9 Clamp

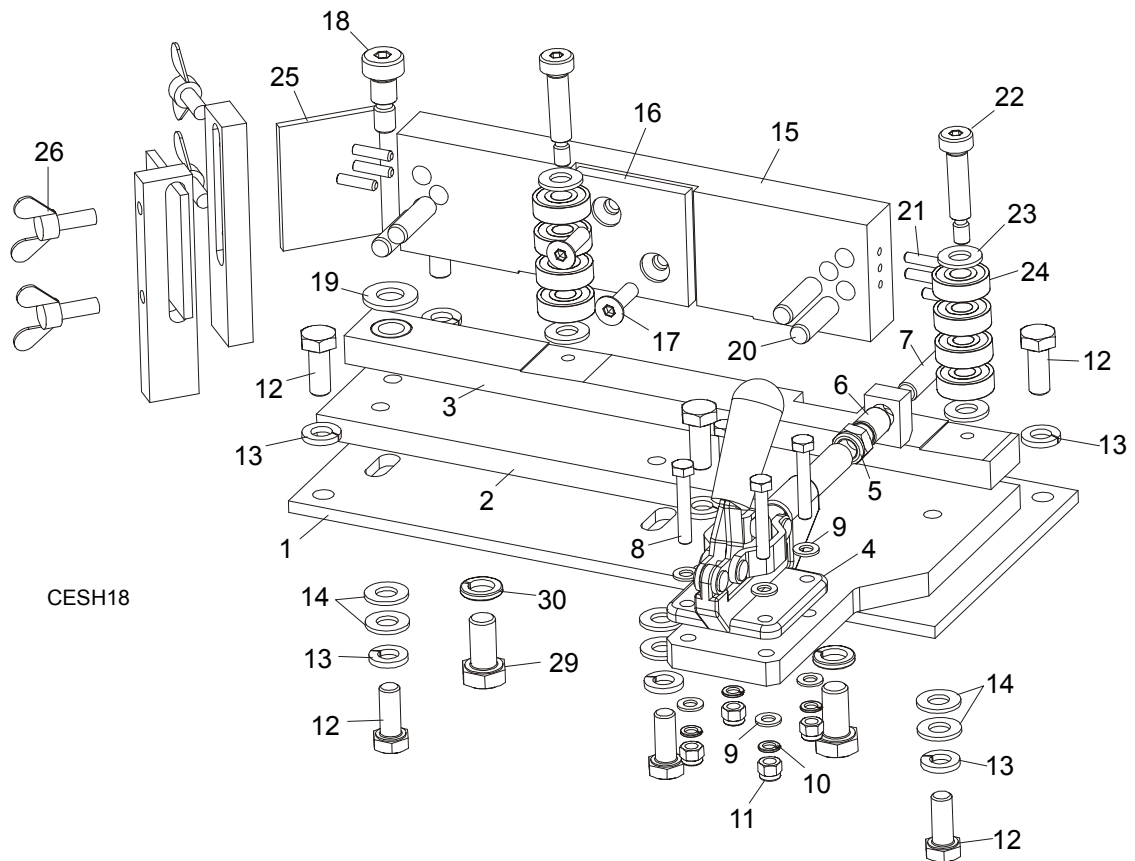

REF	DESCRIPTION (◆ Indicates Parts Available In Assemblies Only)	PART #	QTY.	
	CLAMP ASSEMBLY	N/A	1	
1	Plate, Clamp Mount	087461	1	
2	Plate, Clamp Mount Adjust	087464	1	
3	Arm, Clamp	087467	1	
4	Clamp Assembly	087468	1	
5	Nut, M8-8 Hex Nylon Lock	F81032-2	1	
6	Spring, Clamp	086849	1	
7	Bolt, M8 X 45-8.8 Hex Head	F81002-17	1	
8	Bolt, M5 X 30-5.8 Hex Head	F81000-9	4	
9	Washer, 5.3 Flat	F81052-1	8	
10	Washer, 5.1 Split Lock	F81052-2	4	
11	Nut, M5-8 Hex	F81030-2	4	
12	Bolt, M8 X 20-8.8 Hex Head	F81002-4	7	
13	Washer, 8.2 Split Lock	F81054-4	7	
14	Washer, 8.4 Flat	F81054-1	6	
15	Block, Back Clamp	087462	1	

6**Parts**
Clamp

16	Plate, Clamp Wear	087463	1	
17	Screw, M6 X 20-10.9	F81001-17	2	
18	Bolt, 10/M8 X 12-12.9 Socket Head	F81003-62	1	
19	Washer, 10.5 Flat	F81055-1	1	
20	Pin, 8h6 X 28	F81048-4	4	
21	Screw, M4 X 20-45H	F81000-16	6	
22	Bolt, 8/M6 X 30-12.9 Socket Head	F81001-18	2	
23	Washer, 8.4 Flat	F81054-1	4	
24	Bearing, 608-2RS	086197	8	
25	Wiper, Blade	087608	2	
26	Screw, M6 X 16 Thumb	F81001-16	4	
27	Bolt, M10 X 20-5.8 Hex Head	F81003-1	2	
28	Washer, 10.2 Split Lock	F81055-2	2	

6.10 Grinder

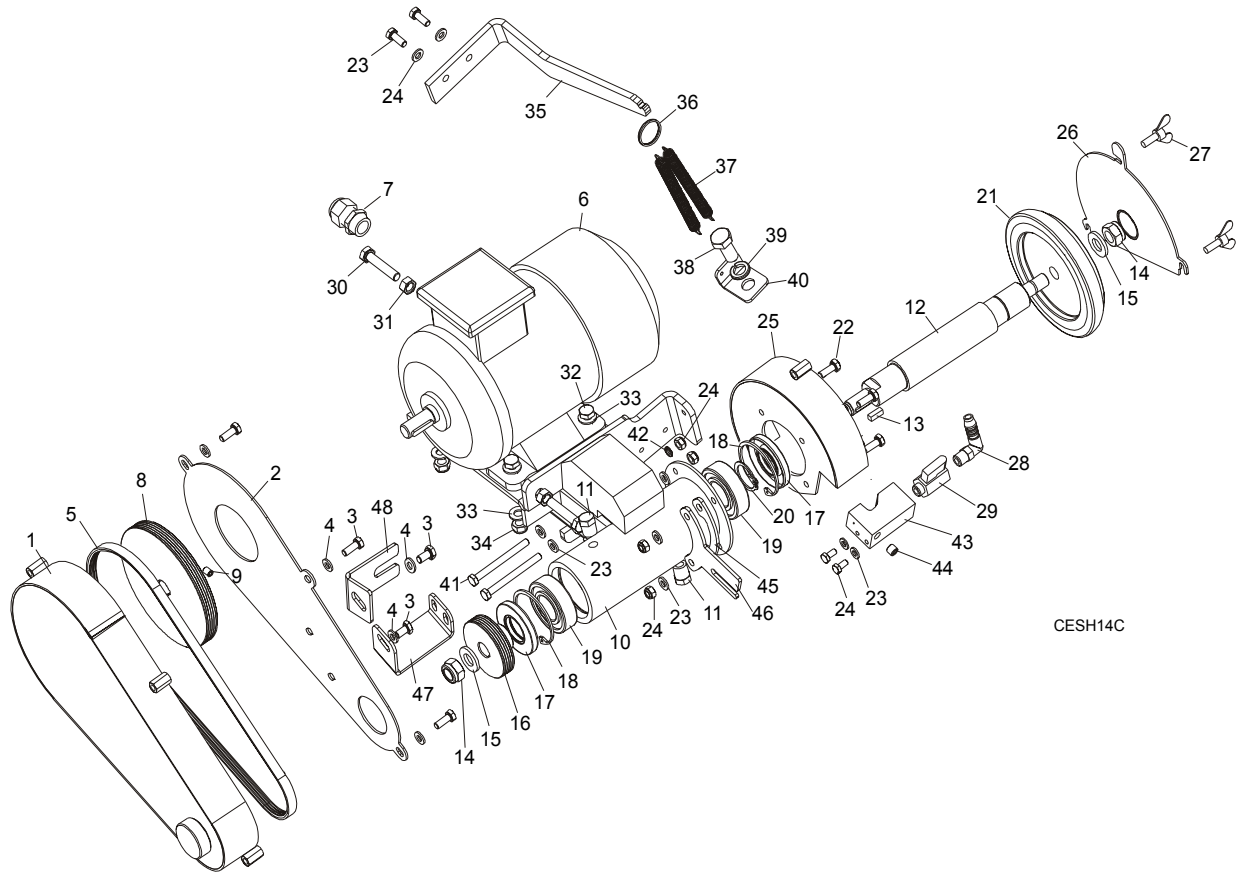

REF	DESCRIPTION (◆ Indicates Parts Available In Assemblies Only)	PART #	QTY.
	GRINDER ASSEMBLY	N/A	1
1	Guard Weldment, Belt Grinder	087494-1	1
2	Guard Weldment, Side Belt Grinder	088099-1	1
3	Bolt, M6x16 8.8 Zinc, Hex Head	F81001-15	5
4	Washer 6,4 Flat	F81053-1	5
5	Belt, OPTIBELT 4PJ711Gear	087559	1
6	Motor, Grinder	087691	1
7	Seal, Gland	085388	1
8	Pulley, Gearbelt	087364	1
9	Screw, M6 X 8	F81013-1	1
10	Spindle Head Weldment	087360-1	1
11	Plug, 1/4"	087605	2
12	Shaft, Grinder	087352	1
13	Key, Spindle	087365	1
14	Nut, M12-8 Hex Nylon Lock	F81034-2	2
15	Washer, 13 Flat	F81056-1	2

16	Pulley, Gearbelt	087363	1	
17	Bearing, 25 X 52 X 7 Retaining	087354	2	
18	Ring, W52 Retaining	F81090-6	2	
19	Bearing, SKF 6205-2RS Roller	087353	2	
20	Ring, Z25 Retaining	F81090-8	1	
21	WHEEL, 10/30 LTAGA GRINDING CBN PROFILE	030381	1	
22	BOLT, M6 X 16-8.8 HEX HEAD	F81001-15	6	
23	WASHER, 6.4 FLAT	F81053-1	6	
24	NUT, M6-8 HEX	F81031-2	4	
25	WRAP, WHEEL WELDMENT	087489-1	1	
26	COVER, FRONT GUARD	087806-1	1	
27	SCREW, M6 X 16 THUMB	F81001-14	3	
28	FITTING WES 10/R 1/4 ELBOW	088379	1	
29	SHUT-OFF VALVE FP60.KIT 28 G1/4	088380	1	
30	BOLT, M8 X 40-8.8HEX HEAD	F81002-15	1	
31	NUT, M8-8 HEX	F81032-1	1	
32	BOLT, M8 X 30-8.8HEX HEAD	F81002-7	4	
33	WASHER, 8.4 FLAT	F81054-1	4	
34	NUT, M8-8 HEX	F81032-2	4	
35	LEVER, GRINDER HEAD CLAMP	088210	1	
36	WHEEL, SPRING/LEVER	085410	1	
37	SPRING, 3/8 X 4.5 X 1/32	P12437	2	
38	BOLT, M12 X 25-8.8 HEX HEAD	F81004-31	1	
39	WASHER, Z12.2 SPLIT LOCK	F81056-2	1	
40	BRACKET, CLAMP SPRING	088211	1	
41	BOLT, M6 X 65-8.8 HEX HEAD	F81001-81	2	
42	WASHER, Z6.1 SPLIT LOCK	F81053-3	2	
43	OLIER	088239	1	
44	PLUG M10X1 DIN 906 BN40 "BOSSARD"	F81015-3	1	
45	OILER WASHER	088351-1	1	
46	BRACKET, OILER MOUNT	088353-1	1	
47	BRACKET, CBN-AC BELT COVER MOUNT	087560-1	1	
48	BRACKET, BELT COVER MOUNT	088366-1	1	

6.11 Drip Pan/Pump

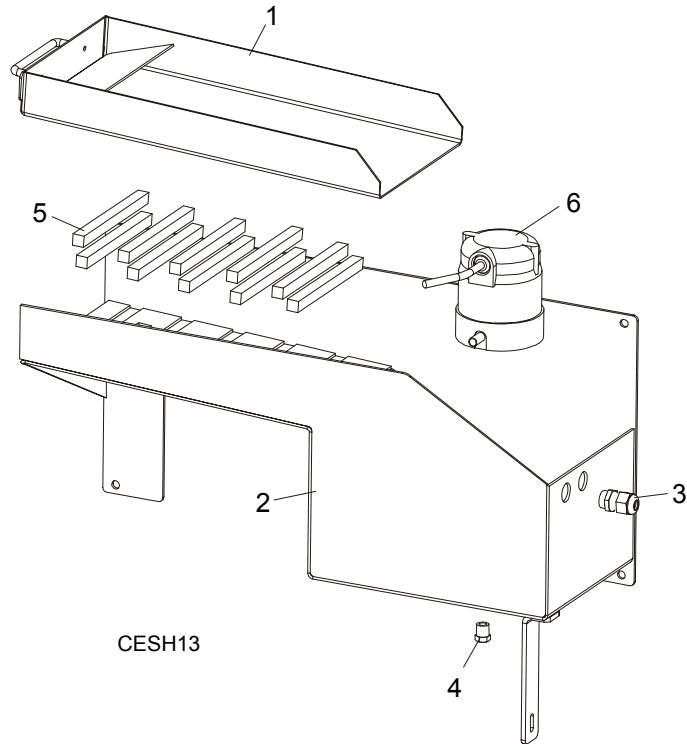

REF	DESCRIPTION (◆ Indicates Parts Available In Assemblies Only)	PART #	QTY.	
1	PAN WELDMENT, FILTER	087925	1	
2	TANK ASSEMBLY, OIL	087916-1	1	
3	SEAL, GLAND	085388	1	
4	PLUG, 1/4"	087605	1	
5	MAGNET, OIL FILTER	P31347	10	
6	PUMP, SUMP OIL GRIDER	P09836	1	

6.12 Control Panel/Box

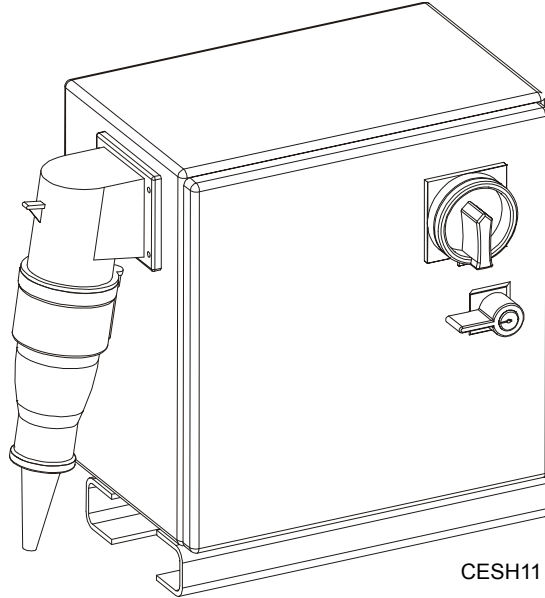

REF	DESCRIPTION (◆ Indicates Parts Available In Assemblies Only)	PART #	QTY.
	BOX ASSEMBLY, SHARPENER CONTROL WITH COMPONENTS (See Section 7)	087690	1

7.2 Electrical Component List

Component	Manufacturer Part No.	Manufacturer	Wood-Mizer Part No.	Description
Q	VCCF01	Schneider	--	Main Disconnecter
1S, 2S, 3S	LC1K0910 B7	Schneider	084451	Contactor
M1	STg71X-2C	BESEL	--	Motor, Grinding
F1, F2	C60N 24336 10A	Schneider	--	Switch
F3, F4, F5	--	Schneider	--	Switch
M2	--	USA	P09836	Motor, Coolant Pump
Tr	--	--	--	Transformer
L1	XB6AV1BB	Schneider	087398	Lamp, Start
Pr	GBPC3510	--	084318	Bridge-Rectifier
M3	--	USA	P09698-1	Motor, Index
P1	XB4 BS542	Schneider	086556	Switch, Emergency Stop
P2, P3, P4	XB4BW84B5	Schneider	087349	Switch, Start-Stop

7.3 Component Layout Diagram

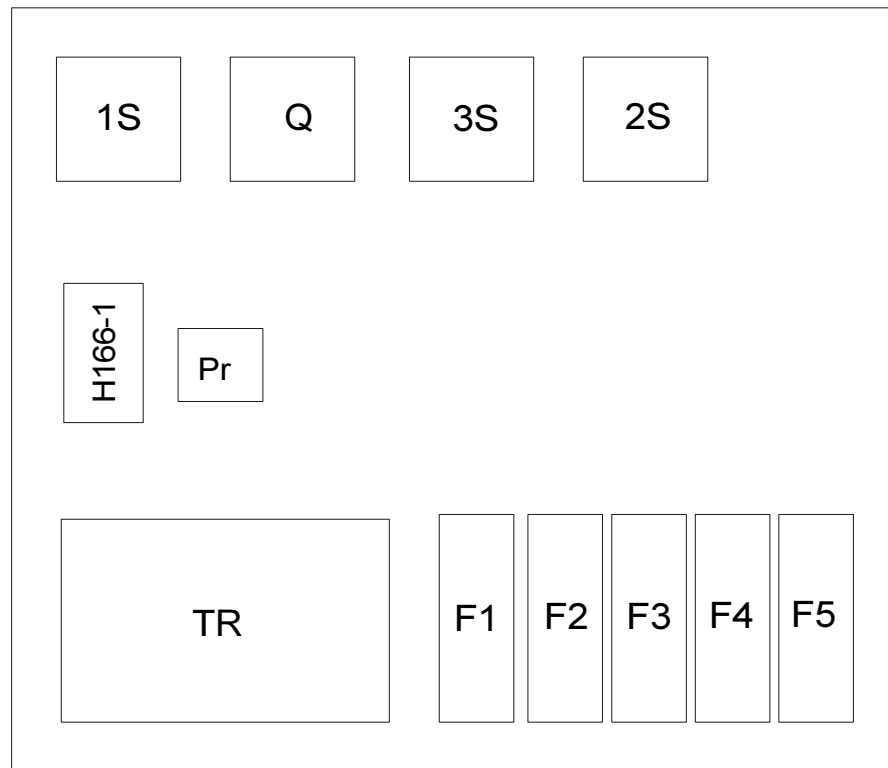

CECH21

FIG. 7-2