

Surge Brake Trailer Kit

Safety, Operation, Maintenance
& Parts Manual

40TRB-Strailer

D1.14

Safety is our #1 concern!

Form #2494

Models Effected:

All versions of

LT28

LT35

LT40 Manuals and Super Manuals

Also including:

LT40HDG26

LT40HDG26W



WARNING! Read and understand this manual before using this machine.

California
Proposition 65 Warning



WARNING: Breathing gas/diesel engine exhaust exposes you to chemicals known to the State of California to cause cancer and birth defects or other reproductive harm.

- Always start and operate the engine in a well-ventilated area.
- If in an enclosed area, vent the exhaust to the outside.
- Do not modify or tamper with the exhaust system.
- Do not idle the engine except as necessary.

For more information go to **www.P65warnings.ca.gov**.



WARNING: Drilling, sawing, sanding or machining wood products can expose you to wood dust, a substance known to the State of California to cause cancer. Avoid inhaling wood dust or use a dust mask or other safeguards for personal protection.

For more information go to **www.P65Warnings.ca.gov/wood**.

Active Patents assigned to Wood-Mizer, LLC

Wood-Mizer, LLC has received patents that protect our inventions which are a result of a dedication to research, innovation, development, and design. Learn more at: woodmizer.com/patents

©September 1, 2023 Wood-Mizer LLC

Printed in the United States of America, all rights reserved. No part of this manual may be reproduced in any form by any photographic, electronic, mechanical or other means or used in any information storage and retrieval system without written permission from

Wood-Mizer, LLC
8180 West 10th Street
Indianapolis, Indiana 46214

SECTION 1 TIRE SAFETY

1.1 Tire labeling 1-1
 Tire markings 1-1
 Identifying tires 1-1
 Tire Identification Number 1-1
1.2 Recommended tire inflation pressure 1-1
 Recommended cold tire inflation pressure 1-1
 The vehicle tire inflation pressure label and location 1-2
 Consequences of tire under-inflation 1-2
 Proper inflation 1-2
1.3 Glossary 1-3
1.4 Tire care, maintenance, and safety practices 1-4
1.5 Vehicle load limits 1-4

SECTION 2 SURGE BRAKE HITCH

2.1 Operation 2-1

SECTION 3 MAINTENANCE

SECTION 4 REPLACEMENT PARTS

4.1 Overview 4-1
4.2 Hitch 4-2
4.3 Outrigger, Right 4-3
4.4 Outrigger, Front 4-4
4.5 Outrigger, Left 4-5
4.6 Outrigger, Jack Holder 4-6
4.7 Outrigger, Rear 4-7
4.8 Axle Assembly 4-8

SECTION 1 TIRE SAFETY

1.1 Tire labeling

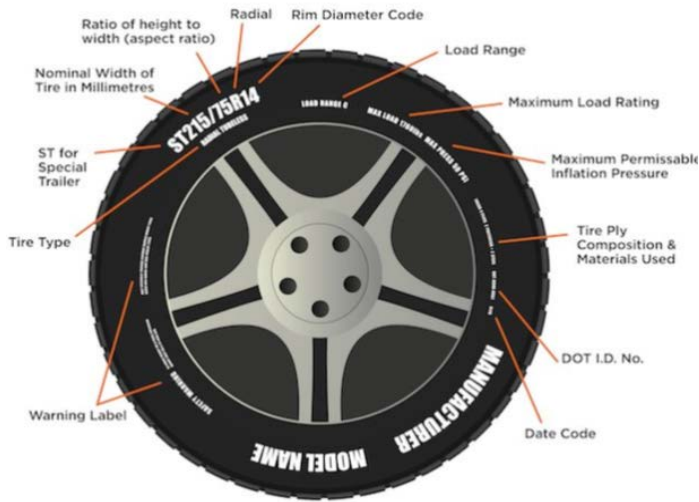

Tire markings

TIRE CLASS AND SIZE: (Example: ST215/75R14)

- **ST** stands for Special Trailer tire. ST trailer tires are built to tow heavy loads, withstand excessive heat, and reduce sway.
- **215** is tire width in millimeters;
- **75** is the aspect ratio, or ratio of height to width;
- **R** is type of construction (radial, in the example)
- **14** is rim diameter in inches.

TIRE TYPE Below the tire size is either 'radial' or 'bias.' Radial tires (or 'radial-ply tires') are constructed with polyester and/or nylon plies that run across the tire perpendicularly, and sometimes include steel belts that run under the tread. Bias-ply tires Bias-ply cords layer in a criss-cross pattern from sidewall to sidewall, and they are also sometimes reinforced with a steel belt.

LOAD RANGE Load range indicates the type of load a tire is designed to support at a specific inflation pressure. Trailer tires typically have C, D, or E load ranges. A load range 'C' tire, for example, is at its peak load capacity—possibly 1600 pounds—when it's inflated to its maximum pressure of 50 PSI. A load range 'C' tire at 25 PSI might be able to support a load of 990 pounds, while at 40 PSI, that capacity could be 1300 pounds.

MAXIMUM LOAD RATING Load rating or load index indicates the weight a tire can safely carry at its maximum air pressure. In the example, at its maximum air pressure of 50 PSI (cold), a load range 'C' tire might have a load rating of 1760 pounds.

MAXIMUM PRESSURE Maximum pressure (when the tires are cold) needed for the tires to carry the maximum load; measured in PSI.

Identifying tires

Tires are required to have a Tire Identification Number (TIN) begin with the letters "DOT," followed by eight to thir-

teen characters that can be used to identify the manufacturing location, tire size, and manufacturer's specifications, along with the week and year the tire was manufactured. DOT Tire Identification Numbers are commonly but erroneously referred to as the tire's serial number, but it actually identifies production *batches*, not individual items.

Regulations also require the entire DOT Tire Identification Number to be branded on one sidewall, while only the letters "DOT" and the first digits of the Tire Identification Number must be branded onto the opposite sidewall. Therefore it is possible to see a Tire Identification Number that appears incomplete, yet simply requires looking at the tire's other sidewall to find the complete Tire Identification Number.

Tire Identification Number

DOT AND DATE CODES Department of Transportation identifier will include 10-12 numbers following 'DOT.' The first six to eight numbers indicate the manufacturer's code, where the tire was manufactured and the tire size.

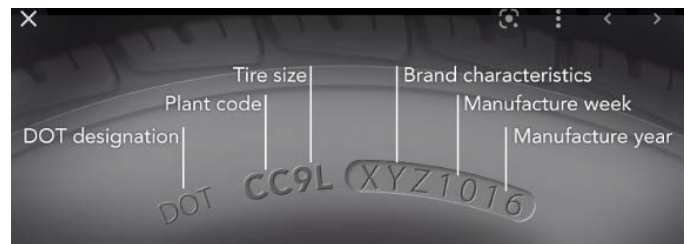

1.2 Recommended tire inflation pressure

Recommended cold tire inflation pressure

The cold inflation pressure is the contained air pressure of a tire that would occur at an indexed temperature of 68°F or 20°C. This indexed temperature is based on the ideal ambient operating conditions for the tire.

Ambient air temperature pressure adjustment tables:

TABLE 1-1 - IMPERIAL MEASUREMENTS

Listed Pressure	10 psi	20 psi	30 psi	40 psi	50 psi	60 psi	70 psi	80 psi	90 psi	100 psi
104°	11.7	22.4	33.1	43.7	54.4	65.1	75.8	86.5	97.1	107.8
86°	10.8	21.2	31.5	41.9	52.2	62.5	72.9	83.2	93.6	103.9
68°	10.0	20.0	30.0	40.0	50.0	60.0	70.0	80.0	90.0	100.0
50°	9.2	18.8	28.5	38.1	47.8	57.5	67.1	76.8	86.4	96.1
32°	8.3	17.6	26.9	36.3	45.6	54.9	64.2	73.5	82.9	92.2
14°	7.5	16.4	25.4	34.4	43.4	52.4	61.3	70.3	79.3	88.3
-4°	6.6	15.3	23.9	32.5	41.2	49.8	58.4	67.1	75.7	84.3
-22°	5.8	14.1	22.4	30.7	39.0	47.3	55.5	63.8	72.1	80.4
-40°	4.9	12.9	20.8	28.8	36.8	44.7	52.7	60.6	68.6	76.5

METRIC MEASUREMENTS

Listed Pres-sure	69 kPa	138 kPa	207 kPa	276 kPa	345 kPa	414 kPa	483 kPa	551 kPa	620 kPa	689 kPa
40°	81	154	228	301	375	449	522	596	670	743
30°	75	146	217	289	360	431	502	574	645	716
20°	69	138	207	276	345	414	483	551	620	689
10°	63	130	196	263	329	396	463	529	596	662
0°	57	122	186	250	314	378	443	507	571	635
-10°	52	113	175	237	299	361	423	485	546	608
-20°	46	105	165	224	284	343	403	462	522	581
-30°	40	97	154	211	269	326	383	440	497	554
-40°	34	89	144	199	253	308	363	418	473	527

The vehicle tire inflation pressure label and location

The generic bilingual tire pressure label appears as in FIG. 1-3. The label on the vehicle has information specific to the trailer filled in

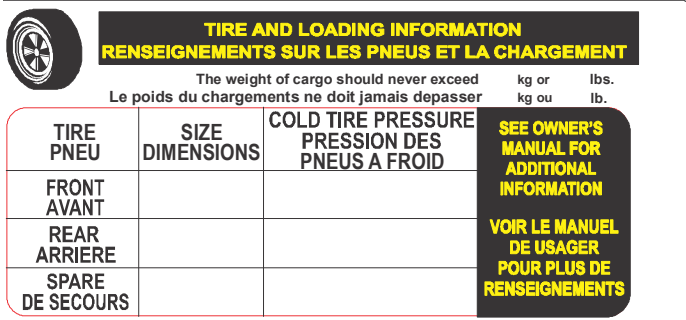

The label is placed near the VIN placard, toward the **front left side** of the trailer.

General area of VIN placard and tire pressure label for Wood-Mizer mill trailers.

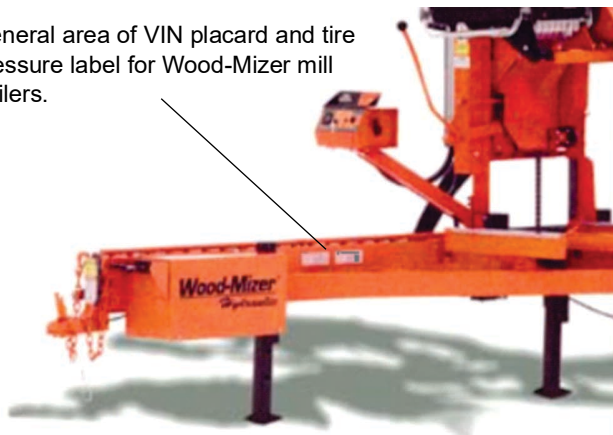

Consequences of tire under-inflation

Underinflated tires and overloaded vehicles are a major cause of tire failure. Tire inflation effects a vehicle's

- steering,
- stopping,

- traction, and
- load-carrying capability.

To avoid flat tires and other types of tire failure, you should

- maintain proper tire pressure,
- observe tire and vehicle load limits,
- avoid road hazards, and
- regularly inspect your tires.

Proper inflation

CHECK TIRE PRESSURE

Use a tire pressure gauge, which you can be purchased at most service stations or auto parts stores. Check the pressure when the tires are **COLD**, as the friction from driving affects the pressure. If driven recently, wait at least three hours for the tires to cool down.



COMMON TIRE PRESSURE GAUGES

1. Remove the cap from the air valve on the tire, and put it somewhere you won't lose it.
2. Press the tire gauge against the open valve stem momentarily.
3. Read the air pressure gauge.
4. Compare this number with the recommended tire pressure.
5. Inflate/release air as needed.
6. Replace the tire's air valve cap.
7. Repeat this process for each tire.

INFLATE YOUR TRAILER'S TIRES

1. Park close enough to the air compressor so you can reach all tires with the hose.
2. If the valve caps are still on, remove them.
3. Press the hose nozzle down on the valve stem.

NOTE: You should notice the tire inflating and feel air flowing through the hose. If not, check to ensure

FIG. 1-4 the hose is securely placed on the valve stem.

4. Remove the hose fitting.
5. Check the air pressure as described above.
6. Repeat steps 3- 5 as needed until the tire is inflated to the correct psi.
7. Repeats steps 2-5 for the vehicle's other tires.

8. Once the tires are inflated properly, replace the valve caps.

RELEASE AIR FROM TIRES

Overinflated tires can lead to poor handling, such as skidding and hydroplaning.

1. Briefly press the small dot or bead on the back of the tire pressure gauge into the center of the valve stem on the tire.

NOTE: You should hear the air escaping the tire.

2. Use the gauge to check the tire pressure.
3. Repeat these steps until you've released enough air to reach the correct psi.

WHEN TO CHECK TIRE PRESSURE

Use Table 1-1 to adjust the recommended cold tire pressure to the ambient temperature. Check tire pressure monthly.

- Most tires may naturally lose air over time.
- Tires can lose air suddenly if you drive over a pothole or other object or if you strike the curb when parking.
- With radial tires, it is usually not possible to determine underinflation by visual inspection.

1.3 Glossary

ALPHA CHARACTER A single alphabetical character from A to Z.

BEAD SEPARATION A breakdown of bond between components in the bead area.

BEAD That part of the tire made of steel wires, wrapped or reinforced by ply cords, that is shaped to fit the rim.

CARCASS PLY A ply that extends to the beads.

CARCASS The tire structure, except tread and sidewall rubber.

CHUNKING The breaking away of pieces of the tread or sidewall.

COLD TIRE PRESSURE The air pressure in a tire at ambient temperature, **not having been driven for the at least 3 hours**.

CORD SEPARATION Cord parting away from adjacent rubber compounds.

CORD The strands that form the plies in the tire.

CRACKING Any parting within the tread, sidewall, or innerliner of the tire extending to cord material.

CURB WEIGHT The weight of a motor vehicle with standard equipment including the maximum capacity of fuel, oil, and coolant, and, if so equipped, air conditioning and additional weight of optional engine.

DEEP TREAD RADIAL A deep tread radial tire is one having a minimum tread depth of 14.3 mm (18/32 inch or 0.5625 inch) or greater.

DOT SYMBOL The letters "DOT" are part of the DOT serial number. This is the manufacturer's certification that the tire or rim meets or exceeds the requirements of FMVSS Nos. 110 and 139.

DOT TIRE IDENTIFICATION NUMBER Number appearing on the sidewall of the tire near the rim required by 49 CFR Part 574.5 which identifies the manufacturer's identification mark, tire size, tire type code and date of manufacture. See Fig. 1-2.

EXTRA LOAD TIRE A tire designed to operate at higher loads and at higher inflation pressures than the corresponding standard tire.

FIELDS Any group of letters and numbers that have significance or meaning.

GAWR The Gross Axle Weight Rating (GAWR) means the value specified by the vehicle manufacturer as the load-carrying capacity of a single axle system, as measured at the tire-ground interfaces.

GROOVE The space between two adjacent tread ribs.

GVWR The Gross Vehicle Weight Rating (GVWR) means the value specified by the manufacturer as the loaded weight of a single vehicle.

INNERLINER SEPARATION The parting of the innerliner from cord material in the carcass.

INNERLINER The layer(s) forming the inside surface of a tubeless tire that contains the inflating medium within the tire.

INTENDED OUTBOARD SIDEWALL (1) The sidewall that contains a whitewall, bears white lettering or bears manufacturer, brand, and/or model name molding that is higher or deeper than the same molding on the other sidewall of the tire; or (2) The outward facing sidewall of an asymmetrical tire having a particular side that must always face outward when mounted on a vehicle.

LIGHT VEHICLE TIRE A new, pneumatic, radial tire intended for use on motor vehicles (other than motorcycles and low speed vehicles) that have a gross vehicle weight rating (GVWR) of 10,000 pounds or less and were manufactured after 1975.

LOAD RATING The maximum load a tire is rated to carry for a given inflation pressure.

MAXIMUM LOAD RATING The load rating at the maximum permissible inflation pressure for that tire.

MAXIMUM INFLATION PRESSURE The maximum cold inflation pressure needed for your tire to support the weight of its **maximum load-carrying capacity**.

MEASURING RIM The rim on which a tire is fitted for physical dimension requirements.

NHTSA/OVSC National Highway Traffic Safety Administration, Office of Vehicle Safety Compliance (Canada).

OPEN SPLICE Any parting at any junction of tread, sidewalls, or innerliner that extends to cord material.

OUTER DIAMETER The overall diameter of an inflated new tire.

OVERALL WIDTH The linear distance between the exteriors of the sidewalls of an inflated tire, including elevations due to marking, decorations, or protective bands or ribs.

PLY A layer of rubber-coated parallel cords.

PLY SEPARATION A parting or rubber compound between adjacent plies.

PNEUMATIC TIRE A mechanical device made of rubber, chemicals, fabric, steel, or other materials, which, when mounted on an automotive wheel, provides the traction and contains the gas or fluid that sustains the load.

RADIAL PLY TIRE A pneumatic tire in which the ply cords that extend to the beads are laid at substantially 90° to the centerline of the tread.

RECOMMENDED INFLATION PRESSURE The cold inflation pressure provided on the Tire Information label and on the VIN tag.

REINFORCED TIRE A tire designed to operate at higher loads and at higher inflation pressures than the corresponding standard tire.

RESPONSIVE TEST A special test initiated through a complaint, field inspection, failed standard test, or COTR discretion. RIM A metal support for a tire or a tire and tube assembly upon which the tire beads are seated.

RIM DIAMETER Nominal diameter of the bead seat.

RIM SIZE DESIGNATION Rim diameter and width.

RIM TYPE DESIGNATION The industry or manufacturer's designation for a rim by style or code. RIM WIDTH Nominal distance between rim flanges.

SECTION WIDTH The linear distance between the exteriors of an inflated tire's sidewalls, excluding elevations due to marking, decoration, or protective bands.

SIDEWALL That portion of a tire between the tread and the bead.

SIDEWALL SEPARATION The parting of the rubber compound from the cord material in the sidewall.

SIZE FACTOR The sum of the section width and the outer diameter of a tire determined on the test rim.

SNOW TIRE A snow tire means a tire that attains a traction index equal to or greater than 110, compared to the ASTM E-1136 Standard Reference Test Tire, when using the snow traction test as described in ASTM F-1805-00, Standard Test Method for Single Wheel Driving Traction in a Straight Line on Snow- and Ice-Covered Surfaces, and which is marked with an Alpine Symbol specified in S5.5(i) of FMVSS No. 139 on at least one sidewall.

TREAD That portion of a tire that comes into contact with the road.

TREAD RIB A tread section running circumferentially around a tire.

TREAD SEPARATION Pulling away of the tread from the tire carcass.

TREADWEAR INDICATORS (TWI) Projections within the principal grooves designed to give a visual indication of the degree of wear of the tread.

UVW The Unloaded Vehicle Weight (UVW) is the weight of a vehicle with maximum capacity of all fluids necessary for vehicle operation, but without cargo, occupants, or accessories that are ordinarily removed from the vehicle when they are not in use.

VEHICLE NORMAL LOAD ON THE TIRE The vehicle normal load on the tire means that load on an individual tire that is determined by distributing to each axle its share of the curb weight, accessory weight, and normal occupant weight and dividing by 2.

1.4 Tire care, maintenance, and safety practices

1. Check your cold tire pressure at least once a month (See [Proper inflation](#))
2. Visually inspect your tires
 - 1). Check the tread at least once a month for excessive or uneven wear.
 - 2). Measure tread depth in three locations across the tire's tread: (1) outer edge, (2) center, and (3) inside edge.

NOTE: Accurate tread depth measurements are made with a simple tread depth gauge available at any parts store.
--Or you can use the quarter (coin) method. Insert a quarter into a tread groove with the top of Washington's head facing down. If the top of his head is not visible, your tires have at least 4/32" of tread and are fine for continued use. If you can see above the top of Washington's head, replace the tire.
 - 3). Inspect for over inflation: wear primarily in the center of the tread, with less wear at the tire's edges.
 - 4). Inspect for under inflation: wear primarily on both edges of the tire tread, with less wear in the center.
 - 5). Inspect for tread wear on one edge of the tire which occurs when the wheels are out of alignment.
 - 6). Inspect for erratic tread wear, "cupping," caused by the wheel out of balance, or suspension components need to be replaced.
 - 7). Inspect for raised portion of the tread or sidewall which may indicate that one of the belts in the tire carcass has separated from those next to it.
3. Have your alignment checked every year.
4. Check and correct your tire balance.

1.5 Vehicle load limits

NOTICE Wood-Mizer trailers are not intended to carry any occupants or cargo.

SECTION 2 SURGE BRAKE HITCH



DANGER! The hitch and safety chains must be secure before towing the sawmill.

Connect the break-away cable to the vehicle when towing the sawmill.

Brake and light connections must be working properly before towing the sawmill.



WARNING! Always check trailer tires for proper inflation before towing sawmill.

Ensure you have complied with all applicable Federal, State and Local motor vehicle safety laws.

2.1 Operation



WARNING! Your vehicle must be equipped with a Class 2 hitch with a solid 2" ball (not two-piece) and rated for at least 3500 pounds (1588 kg). The hitch must be correctly mounted to the towing vehicle so that it will be able to pull this type of load.

1. Pull the mill behind the towing vehicle and place the hitch over the ball coupling on your vehicle.
2. Adjust the coupler so it is as tight as possible on the ball and the locking lever can still be opened and closed.
3. Close the locking handle, ensuring the bracket underneath firmly clamps around the ball.
4. Secure the locking handle with the safety pin.



DANGER! Hitch bracket must be securely fastened around ball before towing the sawmill. Ball must be completely engaged by the hitch bracket and securely locked in place. Use the hitch only with the specified ball size.

5. Cross the safety chains underneath the hitch and hook to the vehicle.

The chains must be connected so that there is still slack in the chains when the vehicle is turned sharply in either direction.



DANGER! Your hitch must have adequate safety chain hookups. **Do not use eye-bolts for safety chain hook-up.** Safety chains should be hooked to bumper of vehicle so that each chain would pull the trailer equally in the event the hitch became disengaged.

6. Connect the surge brake activator cable to the vehicle.

NOTE: This cable should be connected in case the hitch becomes unhooked and the safety chains fail. The surge brake activator cable would then activate the braking mechanism. There should be enough slack in the brake cable that the brake won't engage until the safety chains are stretched tight.

7. Connect the light wiring harness plug from the sawmill to the receptacle on your vehicle. Check signals and brake lights.
8. Raise the outriggers.
9. Recheck that all loose items are removed or secured (such as Resaw Option, Shingle/Lapsiding Option, cant hooks, etc.).

NOTE: The mill should travel horizontal to ground. Adjust the hitch by removing the two mounting bolts, slide the hitch tube to new set of holes, and replace the hardware.

SECTION 3 MAINTENANCE

1. Clean and repack the trailer axle wheel bearings with lithium grease every 12 months or 12,000 miles (19,308 km), whichever comes first.
2. Make sure that the trailer tires are correctly inflated to the pressure shown on the tire. See Section 1.



CAUTION! Always check trailer tires for proper inflation before towing sawmill. Failure to do so may result in machine damage.

3. Check the adjustment of the trailer hitch coupler bracket frequently and adjust if necessary.
4. Replace any bent or otherwise damaged parts before using the hitch; use only parts provided by the hitch manufacturer for this hitch model.
5. Adjust the trailer brakes in these intervals:
 - after the first 200 miles of operation when the brake shoes and drums have “seated”
 - at every 3,000 mile interval
 - as use and performance requires



CAUTION! Refer to Dexter’s website for proper adjustment procedures for axles 600-8000 LBS axle capacity:
<https://www.dexteraxle.com>

If changing a tire, the wheel nut torque should be according to Table 3-1.

Tighten each lug nut in 3 stages.

Wheel Torque Sequence			
Tire Size	1st Stage	2nd Stage	3rd Stage
12”	25	35	50
13”	25	35	50
14”	25	50	90
15”	25	50	90
16”	25	50	90

TABLE 3-1

6. Tighten bolts or nuts in the sequence shown for Wheel Torque Requirements as shown in FIG. 3-1.

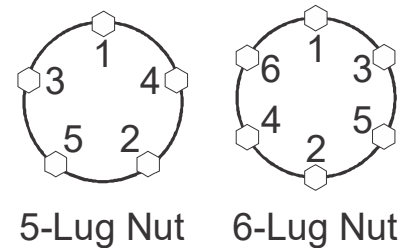

FIG. 3-1

7. Access the outrigger grease fitting by raising the outrigger base all the way -- the grease fitting will be accessible through the lowest outrigger hole.
8. Use one squeeze of a NLGI No. 2 grade lithium grease from a grease gun to lubricate the outrigger.
9. Remove any sawdust.

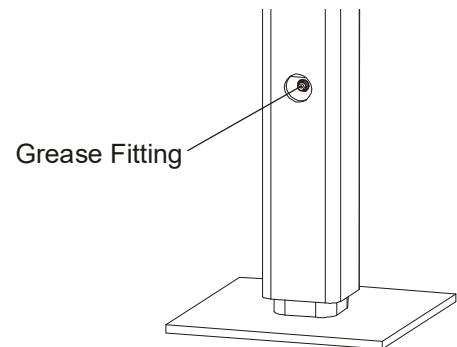
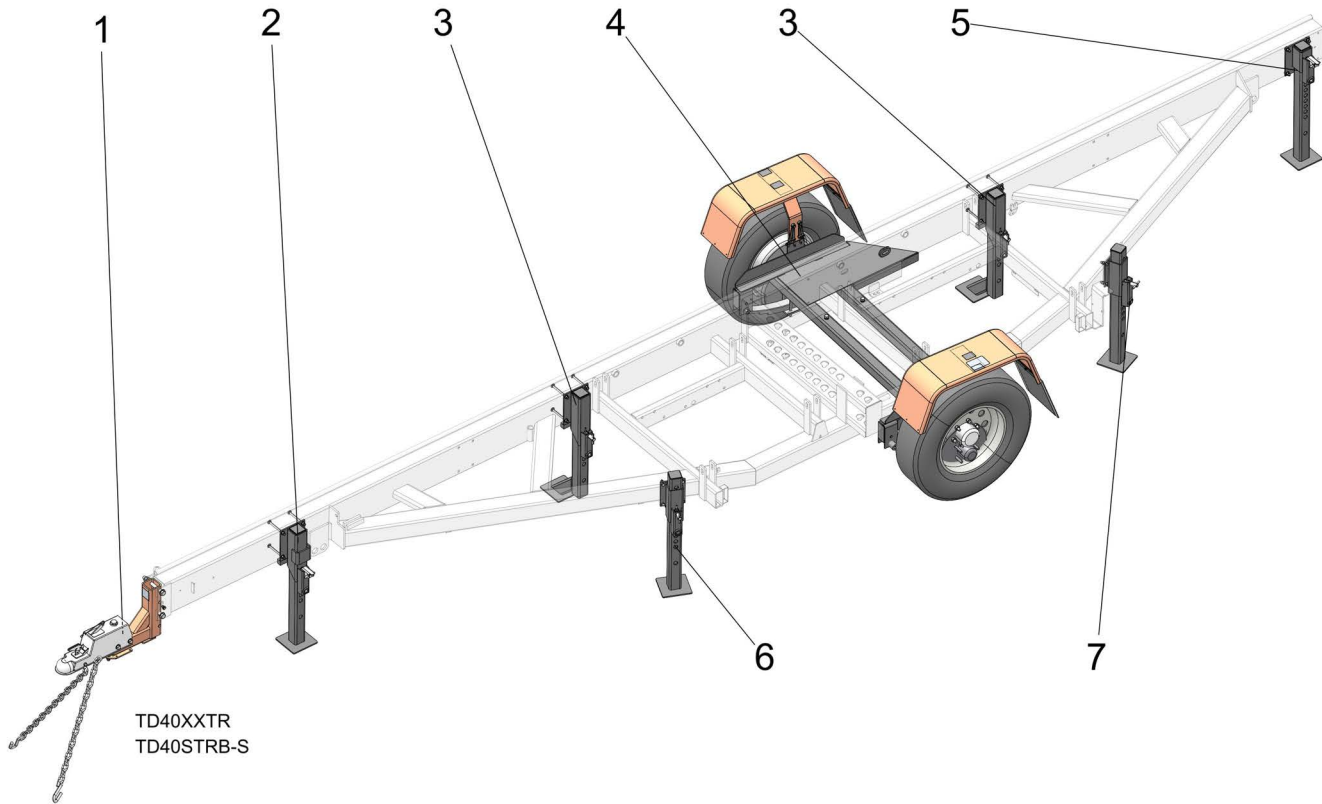

FIG. 3-2

SECTION 4 REPLACEMENT PARTS

4.1 Overview



REF	PART #	DESCRIPTION	COMMENTS	QTY.
1	015398	Hitch Assembly, Surge Brake		2
2	015143	Outrigger Assy, Front 1997		1
3	012997	Outrigger Assy, Right '96		2
4		Axle Assembly		1
5	A12083	Assy, Rear Outrigger		1
6	A04278	Guide, Outrigger Left Assy		1
7	A09475	Guide Assy, Outrigger W/Jack Holder		1
8	036362	Harness, 40TR Wiring	Not Shown	1
9	K10049	Brake Kit, Hyd Plumbing	Not Shown	1

4.2 Hitch

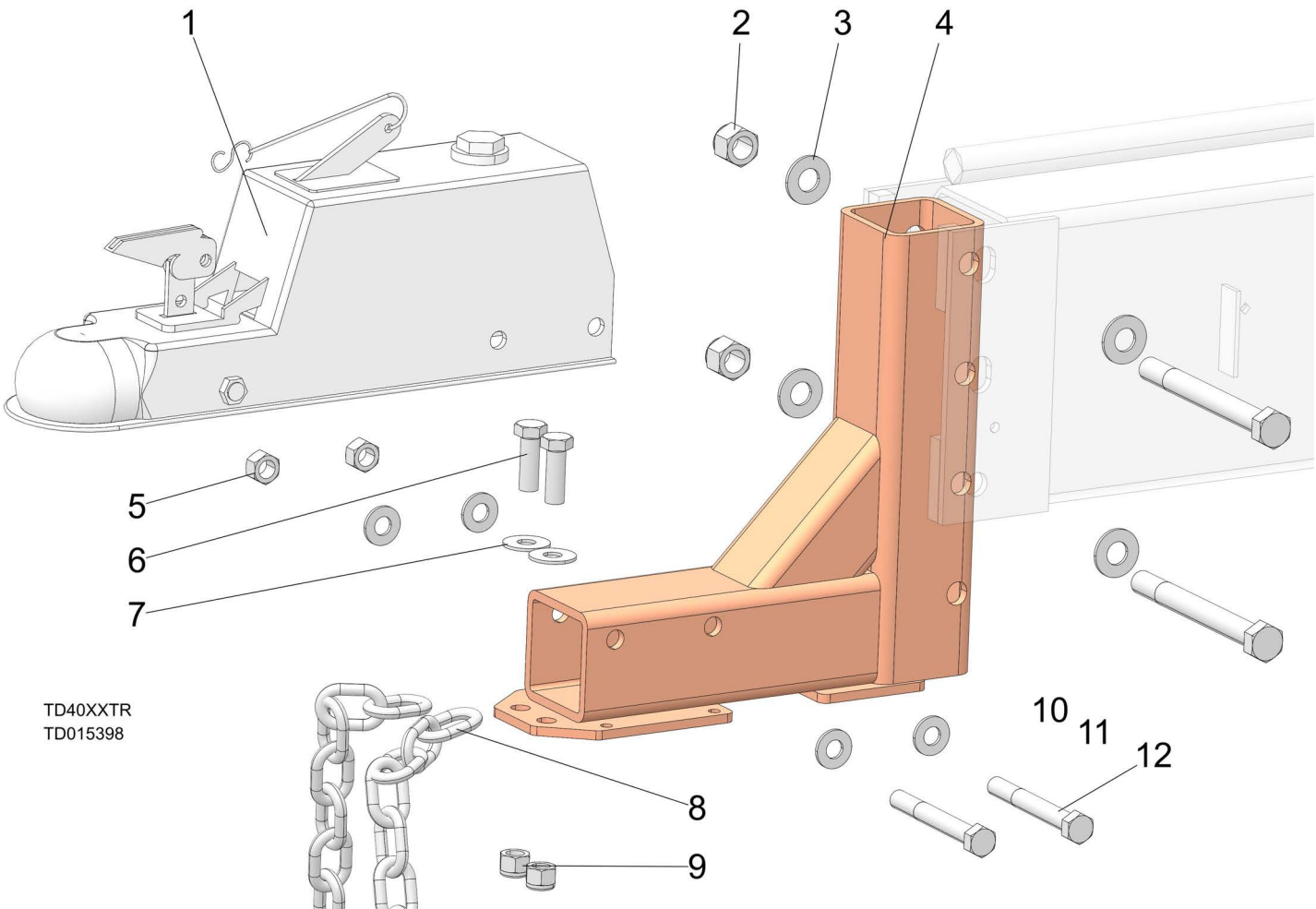

TD40XXTR
TD015398

REF	PART #	DESCRIPTION	COMMENTS	QTY.
1	P09840	Actuator, Surge Brake Hitch, Mod		1
2	F05010-34	Nut, 5/8-11 Nyl Lock		2
3	F05011-5	Washer, 5/8 SAE Flat		4
4	015398	Hitch Wldmt, Surge Brake		1
5	F05010-3	NUT, 1/2-13 SWAGED HEX		2
6	F05008-33	Bolt, 1/2-13x1 1/2 HH Gr5		2
7	F05011-35	WASHER, 7/16 STANDARD FLAT		2
8	107163	Chain, 30 Inch Safety		2
9	F05010-8	Nut, 1/2-13 Nyl Hex Lock		2
10	F05011-2	Washer, 1/2 SAE Flat		4
11	F05009-22	Bolt, 5/8-11x6 Gr5 HH		2
12	F05008-78	1/2-13 x 4 HHB GR5 ZINC		2

4.3 Outrigger, Right

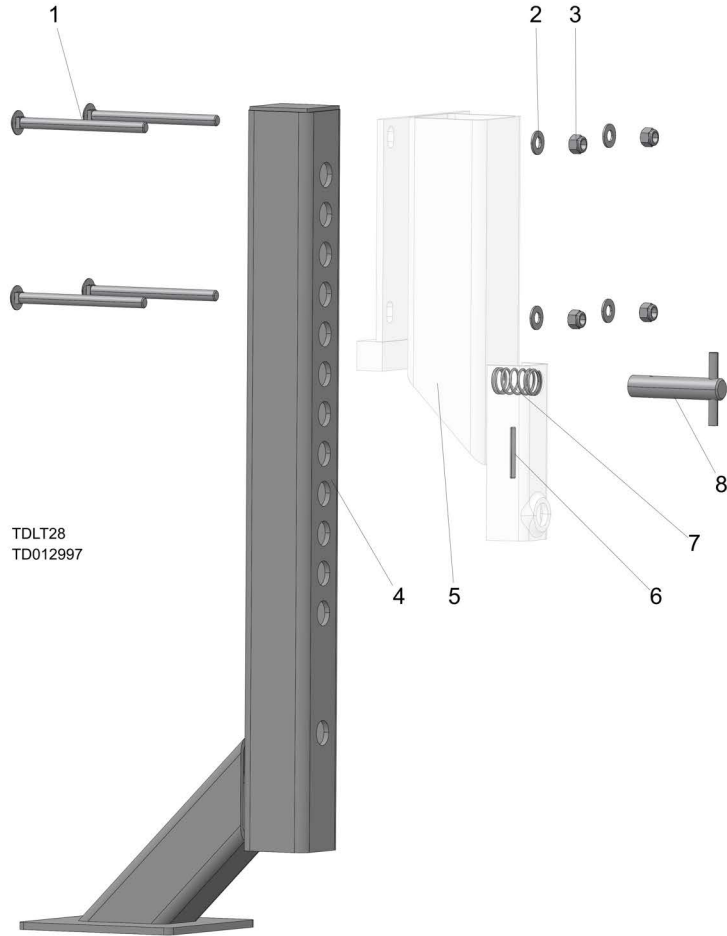

REF	PART #	DESCRIPTION	COMMENTS	QTY.
1	F05007-113	Bolt, 3/8-16x5 Carriage		4
2	F05011-3	Washer, 3/8 Flat SAE		4
3	F05010-10	Nut, 3/8-16 Hex Nyl Lock		4
	012997	Outrigger Assy, Right		2
4	016401	Leg Wldmt, Outrigger Extended		1
5	012996	Guide, Right Outrigger Wldmt '96		1
6	F05012-103	Pin, 3/16x1 3/4 Roll Zinc		1
7	016145	Spring, .92x1.5x.079 Compression		1
8	016148	Pin Assy, .75 Outrigger Pull		1

4.4 Outrigger, Front

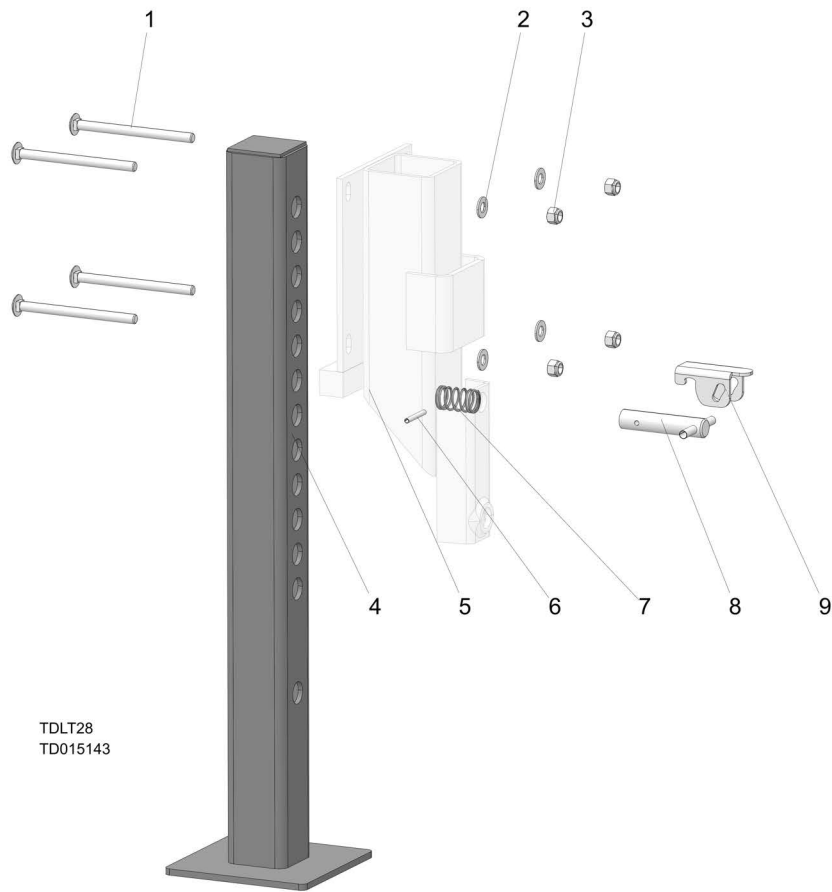

REF	PART #	DESCRIPTION	COMMENTS	QTY.
	015143	Outrigger Assy, Front		1
1	F05007-113	Bolt, 3/8-16x5 Carriage		4
2	F05011-3	Washer, 3/8 Flat SAE		4
3	F05010-10	Nut, 3/8-16 Hex Nyl Lock		4
	015143	Outrigger Assy, Front		
4	W07537	Leg Wldmt, Painted Outrigger		1
5	015144	Guide Wdmt, Front Outrigger 1997		1
6	F05012-17	Pin, 3/16x1 1/2 Roll		1
7	016145	Spring, .92x1.5x.079 Compression		1
8	007736	Pin Assy, Outrigger W/Lock		1
9	064001	Plate, Outrigger Pin Lock		1

4.5 Outrigger, Left

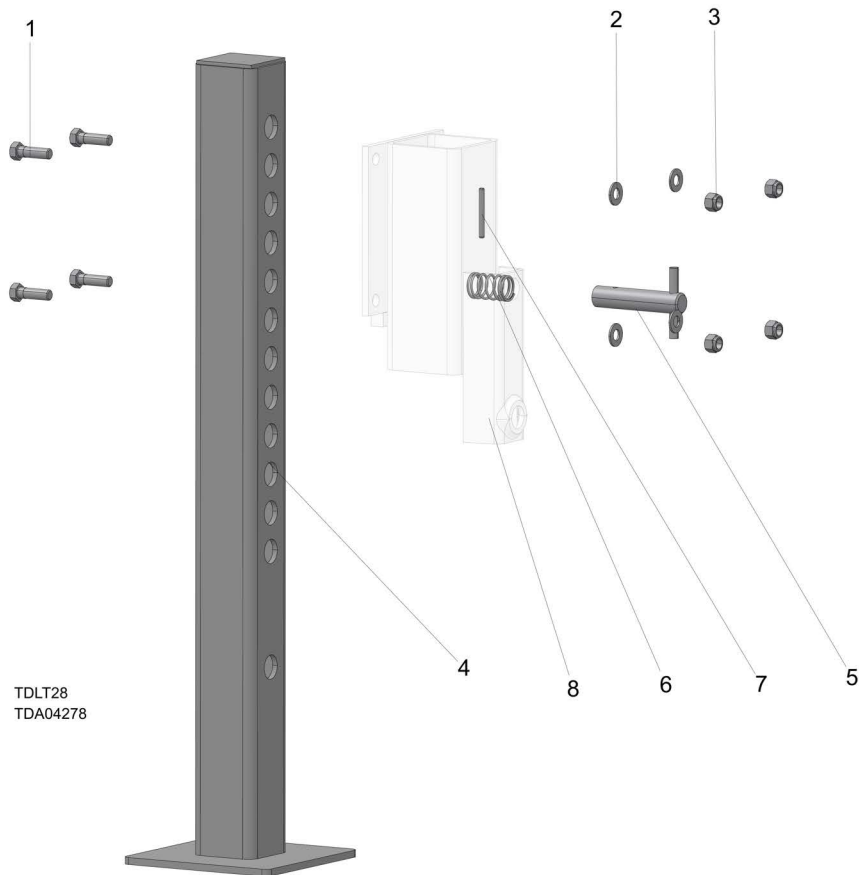

REF	PART #	DESCRIPTION	COMMENTS	QTY.
1	F05007-2	Bolt, 3/8-16x1 1/4 HH Gr2		4
2	F05011-3	Washer, 3/8 Flat SAE		4
3	F05010-10	Nut, 3/8-16 Hex Nyl Lock		4
4	W07537	Leg Wldmt, Painted Outrigger		1
5	016148	Pin Assy, .75 Outrigger Pull		1
6	016145	Spring, .92x1.5x.079 Compression		1
7	F05012-103	Pin, 3/16x1 3/4 Roll Zinc		1
8	W09012	Guide Wldmt, Left Outrigger, Ptd		1

4.6 Outrigger, Jack Holder

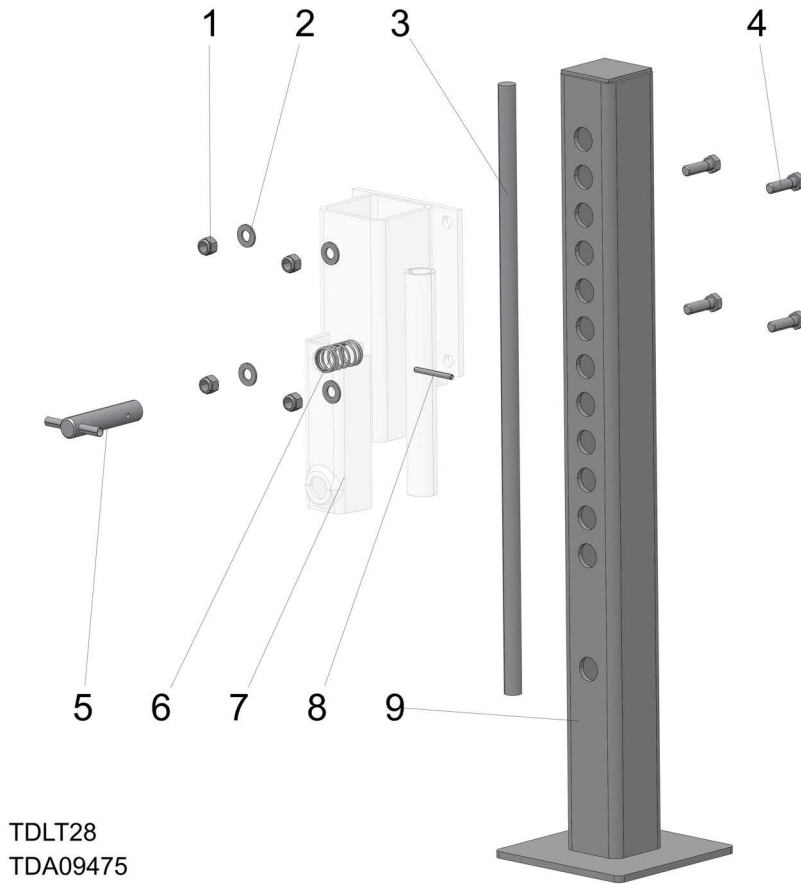

TDLT28
 TDA09475

REF	PART #	DESCRIPTION	COMMENTS	QTY.
1	F05010-10	Nut, 3/8-16 Hex Nyl Lock		4
2	F05011-3	Washer, 3/8 Flat SAE		4
3	S04827	Handle, Outrigger Jack		1
4	F05007-2	Bolt, 3/8-16x1 1/4 HH Gr2		4
	A09475	Guide Assy, Outrigger W/Jack Holder		1
5	016148	Pin Assy, .75 Outrigger Pull		1
6	016145	Spring, .92x1.5x.079 Compression		1
7	W09472	Guide Wldmt, Outrigger W/Handle Holder		1
8	F05012-103	Pin, 3/16x1 3/4 Roll Zinc		1
9	W07537	Leg Wldmt, Painted Outrigger		1

4.7 Outrigger, Rear

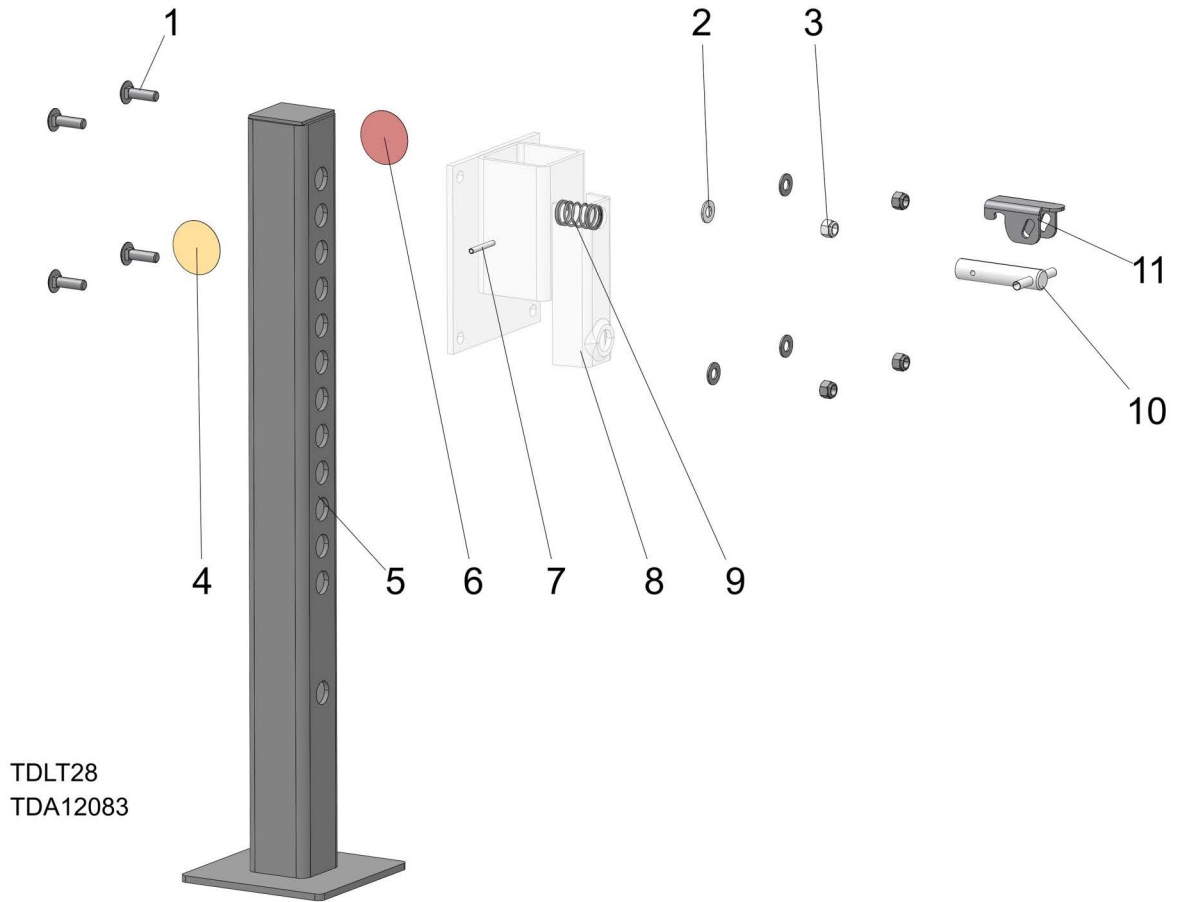

REF	PART #	DESCRIPTION	COMMENTS	QTY.
1	F05007-11	Bolt, 3/8-16x1 1/4 Carriage		4
2	F05011-3	Washer, 3/8 Flat SAE		4
3	F05010-10	Nut, 3/8-16 Hex Nyl Lock		4
	A12083	Assembly, Rear Outrigger		1
4	P07453	Reflector, 2 Dia Amber		1
5	W07537	Leg Weldment, Painted Outrigger		1
6	P07452	Reflector, 2 Dia Red		1
7	F05012-17	Pin, 3/16x1 1/2 Roll		1
8	W12082	Guide Weldment, Rear Outrigger, Ptd		1
9	016145	Spring, .92x1.5x.079 Compression		1
10	007736	Pin Assembly, Outrigger W/Lock		1
11	064001	Plate, Outrigger Pin Lock		1

4.8 Axle Assembly

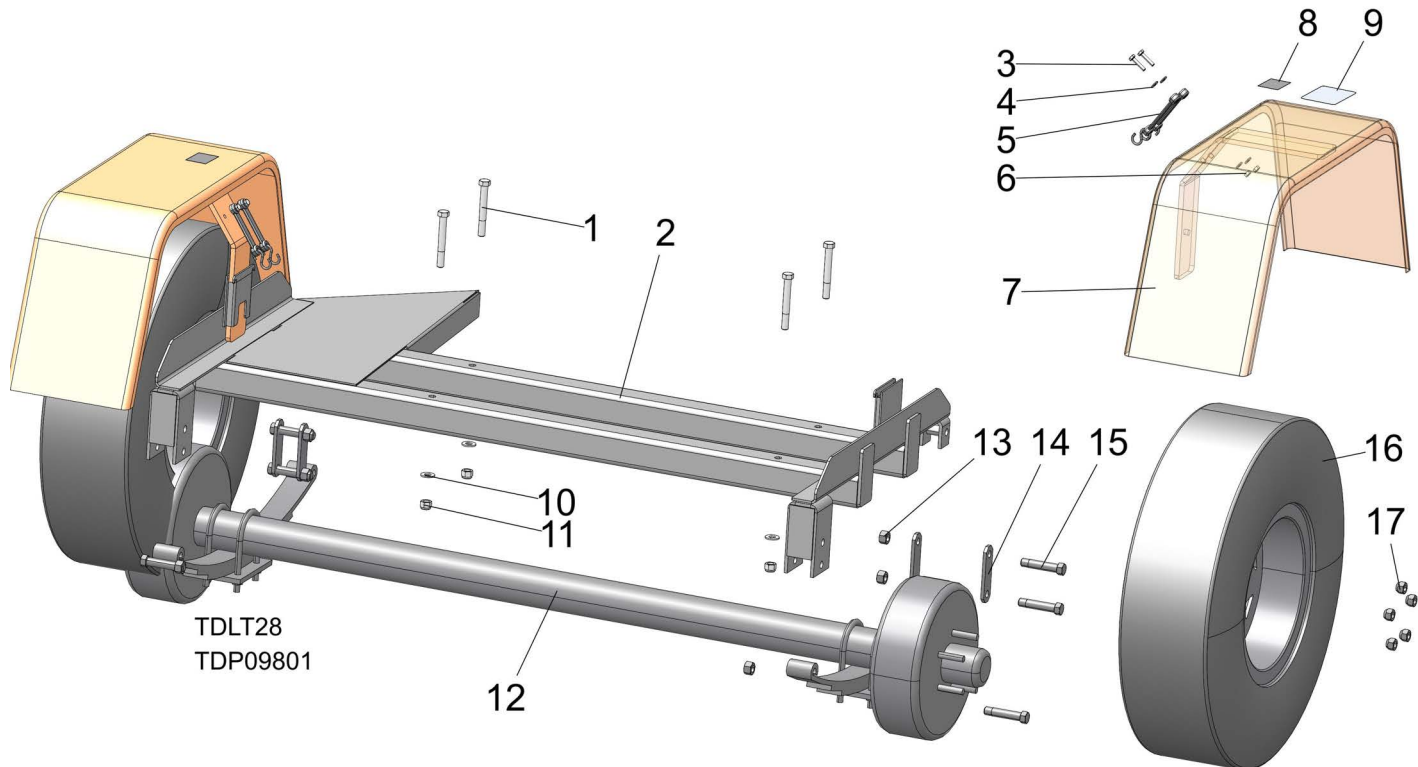

REF	PART #	DESCRIPTION	COMMENTS	QTY.
1	F05008-26	Bolt, 1/2-13x4 HH Gr2		4
2	W09751	Frame Wdmt, Axle Ptd		1
3	F05005-3	Bolt, 1/4-20x1 1/4 HH		4
4	F05011-11	Washer, 1/4 SAE Flat		8
5	016542	Strap, Rubber 6		4
6	F05010-21	Nut, 1/4-20 Swaged		4
7	W11452	Fender Wdmt, 1992 Ptd		2
8	S11761	Decal, Fender Damage Caution		1
9	076607	Decal, Remove Fenders		1
10	F05011-2	Washer, 1/2 SAE Flat		4
11	F05010-8	Nut, 1/2-13 Nyl Hex Lock		4
12	P09801	Axle, Hyd. Brake		1
	P09612	Spring, 2000 Lb. Dexter Leaf		1
	014586	Spring, 2500 Lb. Dexter Leaf		1
	K07549	Bearing Kit, Sawmill Axle Spindle	Service kit for bearings	1
	P04493	Cap, Wheel Bearing Dust		2
	010180	Shoe/Lining Kit, 10" x 2 1/4" Brake	Service kit	1
13	P04643	Nut, 9/16-18 Lock		6
14	M07528	Plate, Axle Shackle Link		4
15	P04644	Bolt, 9/16-18x3 Axle Shackle		6
16	133511	Tire Wheel Assy, St215/75r14 Tamarack		2
17	P04646	Nut, 1/2-20 Lug		10