

# **G35 (formerly G38) Engine**

**Safety, Operation, Maintenance  
& Parts Manual**

---

**003200 Engine Assembly, G35 Kohler rev. D**

---

***Safety is our #1 concern!***

*January 2010*

*Form #1305*

---

**Used with:**

**LT40HD**

**rev. K5.00 - K7.00**

**LT40HD Super**

**rev. J9.01 - K4.00**

**LT50HD**

**rev. A1.01 - A6.00**

---



**WARNING! Read and understand this manual before using this machine.**

**California**  
Proposition 65 Warning



**WARNING:** Breathing gas/diesel engine exhaust exposes you to chemicals known to the State of California to cause cancer and birth defects or other reproductive harm.

Always start and operate the engine in a well-ventilated area.  
If in an enclosed area, vent the exhaust to the outside.  
Do not modify or tamper with the exhaust system.  
Do not idle the engine except as necessary.

For more information go to **[www.P65warnings.ca.gov](http://www.P65warnings.ca.gov)**.



**WARNING:** Drilling, sawing, sanding or machining wood products can expose you to wood dust, a substance known to the State of California to cause cancer. Avoid inhaling wood dust or use a dust mask or other safeguards for personal protection.

For more information go to **[www.P65Warnings.ca.gov/wood](http://www.P65Warnings.ca.gov/wood)**.

**Active Patents assigned to Wood-Mizer, LLC**

Wood-Mizer, LLC has received patents that protect our inventions which are a result of a dedication to research, innovation, development, and design. Learn more at: [woodmizer.com/patents](http://woodmizer.com/patents)

**©2024 Wood-Mizer LLC**

Printed in the United States of America, all rights reserved. No part of this manual may be reproduced in any form by any photographic, electronic, mechanical or other means or used in any information storage and retrieval system without written permission from

**Wood-Mizer, LLC**  
**8180 West 10th Street**  
**Indianapolis, Indiana 46214**

**SECTION 1 ABOUT THIS MANUAL**

**SECTION 2 OPERATION**

2.1 Starting The Engine ..... 2-1

**SECTION 3 MAINTENANCE**

3.1 Safety ..... 3-1  
3.2 Cooling System ..... 3-1  
3.3 Air Cleaner ..... 3-1  
3.4 Fuel Filter ..... 3-2  
3.5 Battery ..... 3-2  
3.6 Alternator Belt ..... 3-2  
3.7 RPM Adjustments ..... 3-2  
3.8 Miscellaneous Maintenance ..... 3-3

**SECTION 4 REPLACEMENT PARTS**

4.1 Fuel Tank (10/15-6/17) ..... 4-1  
4.2 Fuel Tank (1/15-10/15) ..... 4-3  
4.3 Service Fuel Tank (Before 2015) ..... 4-4  
4.4 Engine Mount Assembly ..... 4-5  
4.5 Engine Assembly ..... 4-6  
4.6 Alternator Assembly ..... 4-8  
4.7 Engine Pulley Guards ..... 4-10

## SECTION 1 ABOUT THIS MANUAL

This manual is provided as a supplement to the equipment manufacturer's manuals. This manual provides information specific to the use of this equipment on the Wood-Mizer® sawmill. Refer to the sawmill operator's manual and manufacturer's manual before attempting to operate this equipment.

**NOTICE** Read the sawmill operator's manual and engine manufacturer's manual for instructions and safety precautions before operating this equipment.

The information and instructions given in this manual do not amend or extend the limited warranties for the equipment given at the time of purchase.



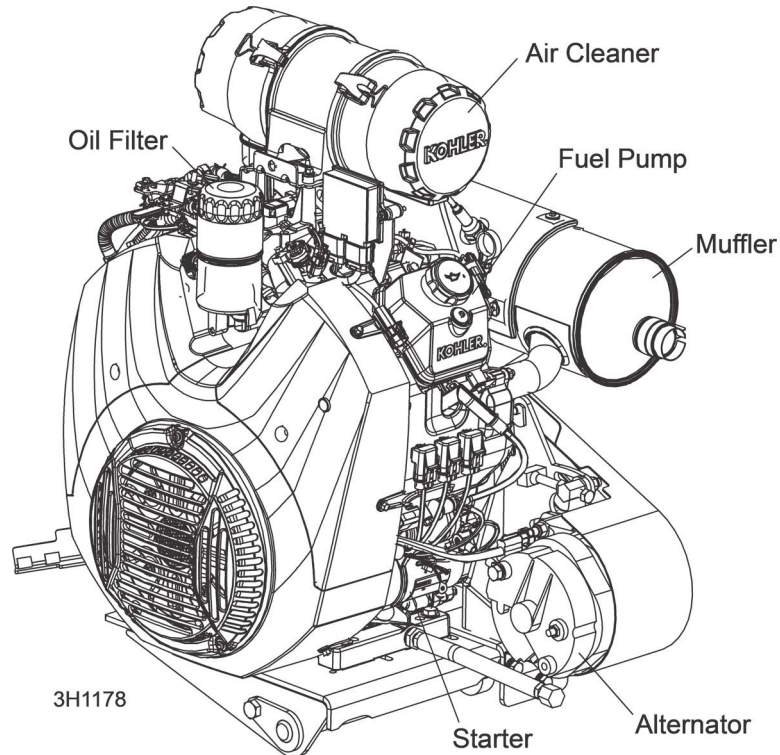

### G38 ENGINE



## SECTION 2 OPERATION

### 2.1 Starting The Engine

#### ENGINE CONTROL PANEL LIGHTS

-  *Alternator Charge Indicator:* Lights up if the alternator is not charging the battery
-  *Engine Temperature Indicator:* Not used.
-  *Key Switch Indicator:* Lights up when the key is in either the on or accessory (#1 or #3) position.
-  *Oil Indicator:* Lights up if the oil pressure is too low. The engine will automatically switch to low idle if a low oil condition occurs.
-  *Glow Plug Indicator:* Not used.

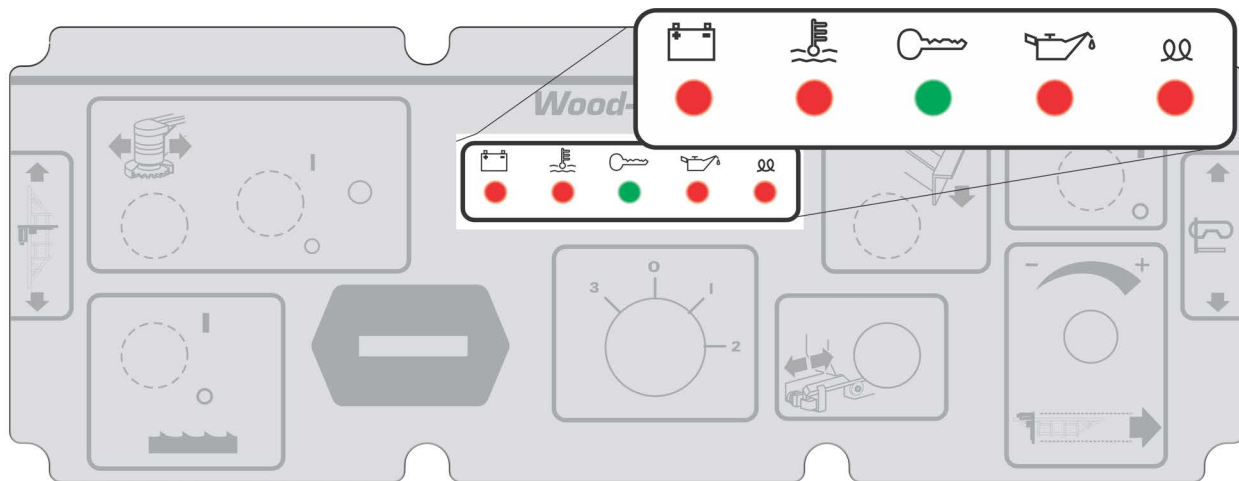

FIG. 2-1

#### ENGINE START

**⚠ DANGER!** Always be sure the blade is disengaged and all persons are out of the path of the blade before starting the motor. Failure to do so will result in serious injury.

**⚠ DANGER!** Operate your engine/machine only in well ventilated areas. The exhaust gases of your engine can cause nausea, delirium and potentially death unless adequate ventilation is present.

**⚠ DANGER!** Never operate an engine with a fuel or oil leak. The leaking fuel or oil could potentially come in contact with hot surfaces and ignite into flames.

**⚠ WARNING!** Be sure the power feed switch is in the neutral position before turning the key switch to the on (#1) or accessory (#3) position. This prevents accidental carriage movement, which may cause serious injury or death.

**⚠ WARNING!** Do not operate engine without proper and operational spark arrester/muffler. Sparks emitted from the engine exhaust could ignite surrounding materials, causing serious injury or death.

**⚠ WARNING!** EPA Compliant Gas Tanks Only: Always relieve all fuel pressure inside the tank prior to filling or connecting fuel fittings. Failure to do so may result in fuel spillage.

**WARNING!** EPA Compliant Gas Tanks Only: Disconnect the fuel tank when not in use or during transportation. Failure to do so may result in engine flooding or fuel spillage.

**NOTE:** When the clutch handle is engaged, an accelerator pump is activated which supplies fuel to the engine carburetor. To avoid flooding the carburetor and possibly fouling the spark plugs, do not engage the clutch lever repeatedly without the engine running.

## **ENGINE SHUTOFF**

Turn the key switch to the off (#0) position.

## SECTION 3 MAINTENANCE

Refer to the manufacturer's manual for maintenance intervals and procedures unless otherwise instructed in this manual. Follow the manufacturer's recommendations for dusty conditions.

**NOTICE** Refer to the manufacturer's manual for complete maintenance instructions. This manual only provides information about additional procedures or procedures to be performed at different time intervals than found in the manufacturer's manuals



**WARNING!** Clean sawdust from all guards, vents, control boxes, or any area where sawdust may gather **after every shift**. Failure to do so may result in fire, causing death or serious injury.



### 3.1 Safety

Use caution when performing maintenance or service to the engine.



**DANGER!** Always be aware of and take proper protective measures against rotating shafts, pulleys, fans, etc. Always stay a safe distance from rotating members and make sure that loose clothing or long hair does not engage rotating members resulting in possible injury.

**DANGER!** Engine components can become very hot during operation. Avoid contact with any part of a hot engine. The exhaust components of your engine are especially hot during and following operation. Contact with hot engine components can cause serious burns. Therefore, never touch or perform service functions on a hot engine. Allow the engine to cool sufficiently before beginning any service function.



**WARNING!** Remove the blade before performing any engine service. Failure to do so may result in serious injury.

**WARNING!** Always wear proper and necessary safety equipment when performing service functions. Proper safety equipment includes eye protection, breathing protection, hand protection and foot protection.

### 3.2 Cooling System

Wash the engine or brush off sawdust and debris every 50 hours of operation. Clean the grass screen, cooling fins, and external surfaces. Remove any dust, dirt or oil. See engine manual for further instructions.

### 3.3 Air Cleaner



**WARNING!** Always wear proper and necessary safety equipment when performing service functions. Proper safety equipment includes eye protection, breathing protection, hand protection and foot protection.

Replace the outer air cleaner cartridge and check the inner cartridge every 250 hours of operation or more often if operating the sawmill in dirty conditions or if engine performance indicates a new cartridge is necessary.



**CAUTION!** Do not clean elements with water or compressed air. Do not handle the inner element unless it is to be changed. Handle new elements carefully. Contact with the element could cause damage and prevent the filter from operating properly.

Replace the inner air cleaner cartridge every 1200 hours of operation or more often if operating the sawmill in dirty conditions.

### 3.4 Fuel Filter

Replace the fuel filter every 100 hours of operation or as required for engine performance.

### 3.5 Battery

Check the battery electrolyte level every 50 hours of operation. See manufacturer's manual for instructions.

**! DANGER!** Batteries expel explosive gases. Keep sparks, flames, burning cigarettes, or other ignition sources away at all times. Always wear safety goggles and a face shield when working near batteries. Failure to do so will cause serious injury.

**! WARNING!** Battery posts, terminals and related accessories contain lead and lead compounds, chemicals known to the State of California to cause cancer and reproductive harm. Wash hands after handling.

### 3.6 Alternator Belt

The belt tension should be checked after the first 100 hours of operation, when the battery is not charging properly or when the alternator belt is squealing.

If the battery continues to not charge properly or the belt continues to squeal after the initial belt adjustment, replace the belt.

1. Release the blade tension and remove the blade from the sawmill if necessary.
2. Turn the key switch to OFF (0) and remove the key.
3. Remove the drive belt cover and alternator cover.
4. Use a belt tension gauge to measure the belt tension.
5. Place the gauge on the belt at the midpoint between the two pulleys.

If the belt has more than 3/16" at 9 lb. of deflection, tighten the belt as described below.

6. Loosen the upper pivot, lower pivot and the adjustment bolt jam nut.
7. Turn the belt tension adjustment bolt clockwise to tighten the belt, counterclockwise to loosen the belt.
8. Adjust the bolt until the proper belt tension is achieved.

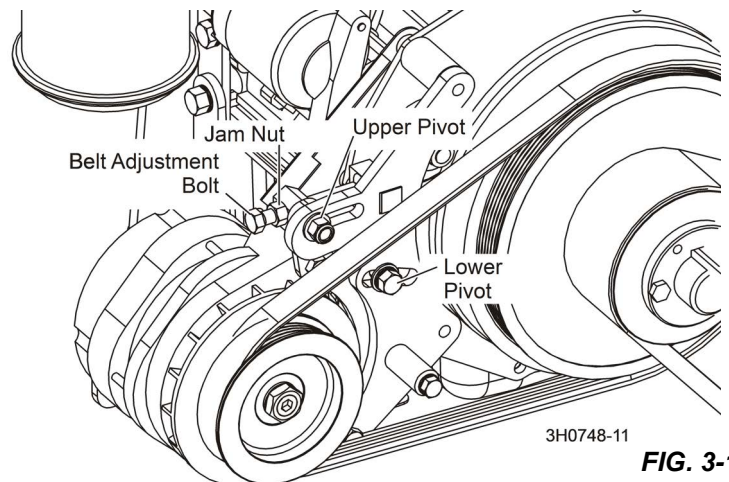

FIG. 3-1

**! CAUTION!** Do not overtighten the alternator belt. Damage to the alternator will occur.

9. After the alternator belt has been tensioned, tighten the adjustment bolt jam nut.
10. Tighten the upper and lower pivots and replace the belt covers.

### 3.7 RPM Adjustments

**! WARNING!** Remove the blade before performing any engine service. Failure to do so may result in serious injury.



1. Make sure belt and brake strap tensions are correct (See Sawmill Maintenance)
2. Check oil, fuel, and coolant levels.

Engine	High End RPM	Low End RPM
G38	3600	1500

3. Check the RPM with a tachometer every 200 hours of operation.
4. Ensure the throttle cable does not affect the engine RPM when the clutch handle is disengaged or the cable is not bent or kinked.

**NOTE:** It is important that the above components are aligned. Proper alignment allows any slack in the cable (when engine is idling) to slide down into the cable spring. This maintains free operation of the cable and prevents the cable from kinking.

5. Ensure the shoulder bolt does not rub against the crankcase vent tube.
6. Start the engine to measure the low-end RPM.
7. Refer to the engine manual to adjust the low-end RPM.
8. Engage the clutch handle to throttle the engine and measure the high-end RPM. The high-end RPM is factory-set at 3600.
9. Readjust the throttle cable if necessary to increase or reduce the high-end engine speed.
10. The throttle cable should be tensioned just enough so that the engine revs as soon as the clutch/brake handle is engaged.

**NOTE:** A properly adjusted throttle will extend the cable spring 1/4" to 3/8" (6.4 - 9.5 mm) when running and have a slight amount of slack in the cable when idling.

### 3.8 Miscellaneous Maintenance

Clean and inspect the spark arrester every 50 hours of operation.

Replace if damaged.

Review the manufacturer's engine manual for maintenance intervals.

## SECTION 4 REPLACEMENT PARTS

### 4.1 Fuel Tank (10/15-6/17)

LT40HD Rev. K6.09 - K7.04  
LT40HD Super Rev. K3.17 - K4.01  
LT50 Rev. A5.17 - A6.01

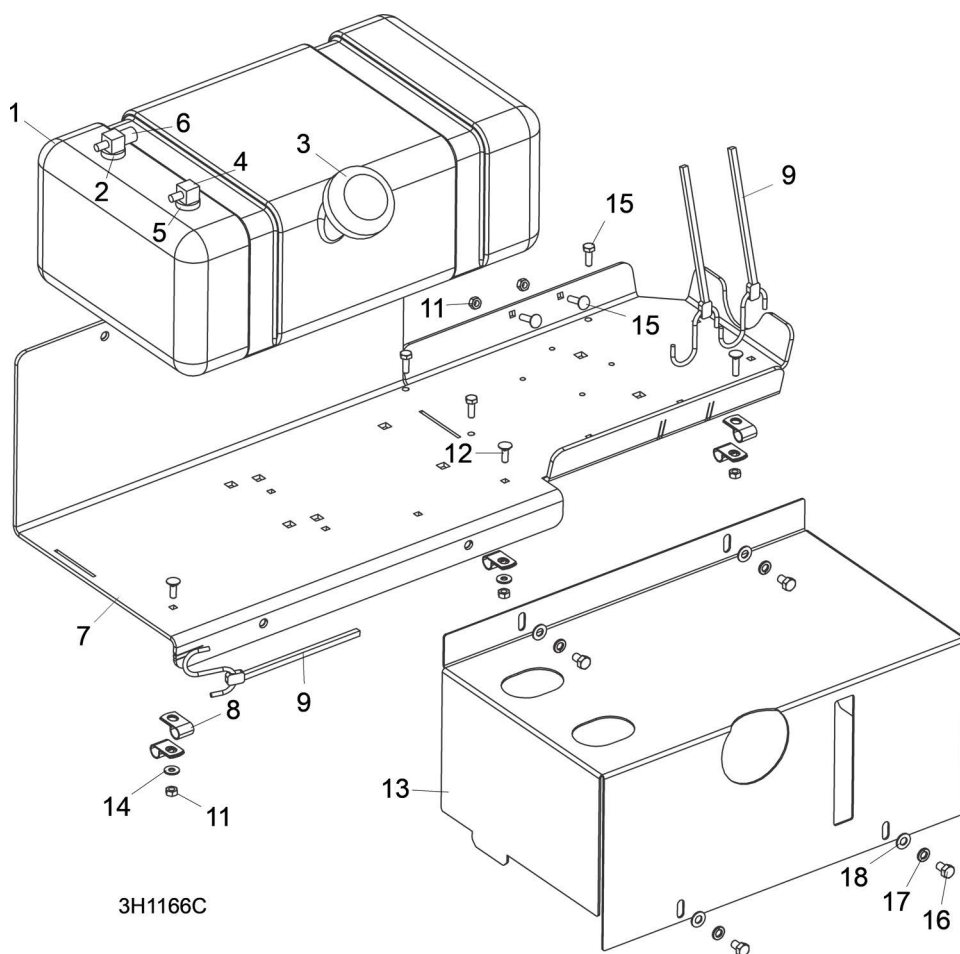

REF	PART #	DESCRIPTION	COMMENTS	QTY.
	074821	<b>TRAY ASSEMBLY, GAS CAN</b>		1
1	103878	Tank, 5 Gallon Low Pro EPA Fuel	Available in assemblies only. Fuel shut-off valve added to fuel tank to prevent possibility of fuel feeding back into engine during travel (LT40 Rev. K4.10/LT40HD Super Rev. K3.20/LT40HD Rev. K6.12/LT50 Rev. A5.20).	1
2	061250	Grommet, Shut Off		1
3	061251	Gas Cap, LT15		1
4	061252	Valve, Slosh		1
5	061253	Grommet, Slosh Valve		1
6	074943	Fitting, Fuel Pick-Up With Shut-Off		1
7	103943	Tank Weldment, Fuel LT40/50		1
8	103867	Cover, Fuel Tank		1

REF	PART #	DESCRIPTION	COMMENTS	QTY.
9	P11668	Strap, 20" Rubber		3
10	F05005-34	Bolt, 1/4-20 X 1" Carriage Head		3
11	F05010-21	Nut, 1/4-20 Hex Lock		5
12	F05005-113	Bolt, 1/4-20 x 3/4" Carriage		2
13	P07584	Clamp, 1/2" EMT Coated		6
14	F05011-11	Washer, 1/4" SAE Flat		2
15	F05005-123	Bolt, 1/4-20 x 3/4" Hex Head Grade 5		3
16	F05006-15	Bolt, 5/16-18 x 1/2" Hex Head Grade 5		4
17	F05011-13	Washer, 5/16" Split Lock		4
18	F05011-17	Washer, 5/16" SAE Flat		4
	R02423-1	Hose, Fuel 3/16" EPA 15G CARB		8 Ft.
	R02423-2	Hose, Fuel 1/4" EPA 15G CARB		8 Ft.

## 4.2 Fuel Tank (1/15-10/15)

LT40HD Rev. K6.07 - K6.08  
 LT40HD Super Rev. K3.15 - K3.16  
 LT50 Rev. A5.15 - A5.16

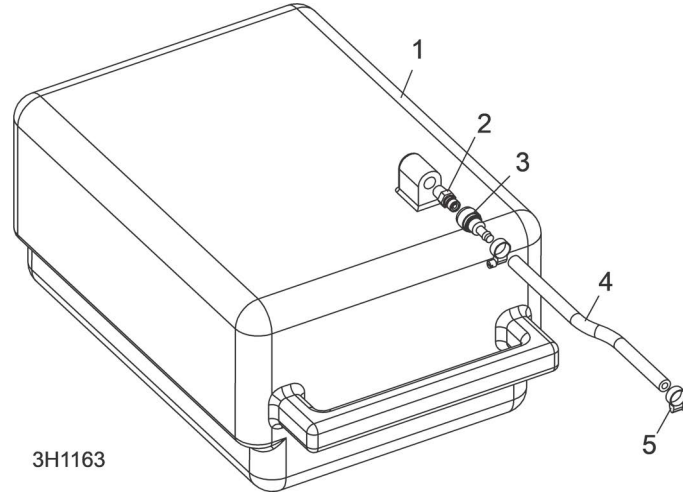

REF	PART #	DESCRIPTION	COMMENTS	QTY.
	074643	<b>TANK ASSEMBLY, 6 GALLON GAS SERVICE</b>		1
1	076478	Tank, Gas	Available in assemblies only.	1
2	015583	Fitting, 1/4" NPT Male Quick Disconnect		1
3	015582	<b>FITTING, FEMALE QUICK DISCONNECT BARB</b>		1
4	R02423-2	<b>HOSE, FUEL 1/4" EPA 15G CARB</b>		6.67 Ft
5	P649	<b>CLAMP, 7/32" - 1/2" HOSE</b>		4

### 4.3 Service Fuel Tank (Before 2015)

LT40HD Prior to Rev. K6.07  
 LT40HD Super Prior to Rev. K3.15  
 LT50 Prior to Rev. A5.15

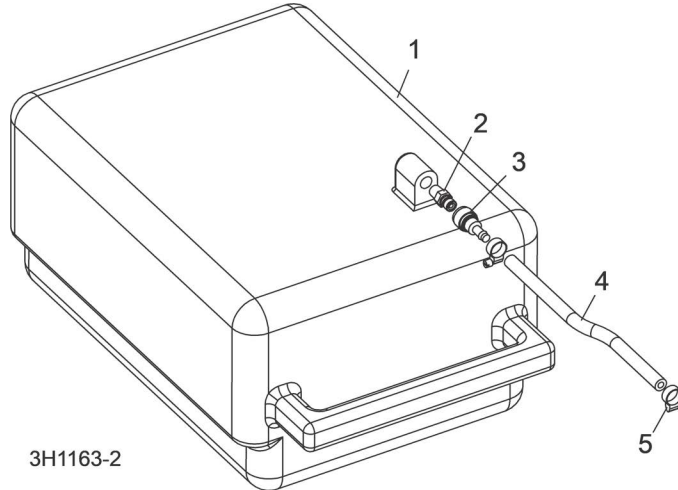

REF	PART #	DESCRIPTION	COMMENTS	QTY.
	074643	<b>TANK ASSEMBLY, 6 GALLON GAS SERVICE</b>  <b>ORIGINAL TANK IS NOT IN COMPLIANCE WITH EPA STANDARDS</b>		1
1	076478	Tank, Gas	Available in assemblies only.	1
2	015583	Fitting, 1/4" NPT Male Quick Disconnect		1
3	015582	<b>FITTING, FEMALE QUICK DISCONNECT BARB</b>		1
4	R02423-2	<b>HOSE, FUEL 1/4" EPA 15G CARB</b>		6.67 Ft
5	P649	<b>CLAMP, 7/32" - 1/2" HOSE</b>		4

## 4.4 Engine Mount Assembly

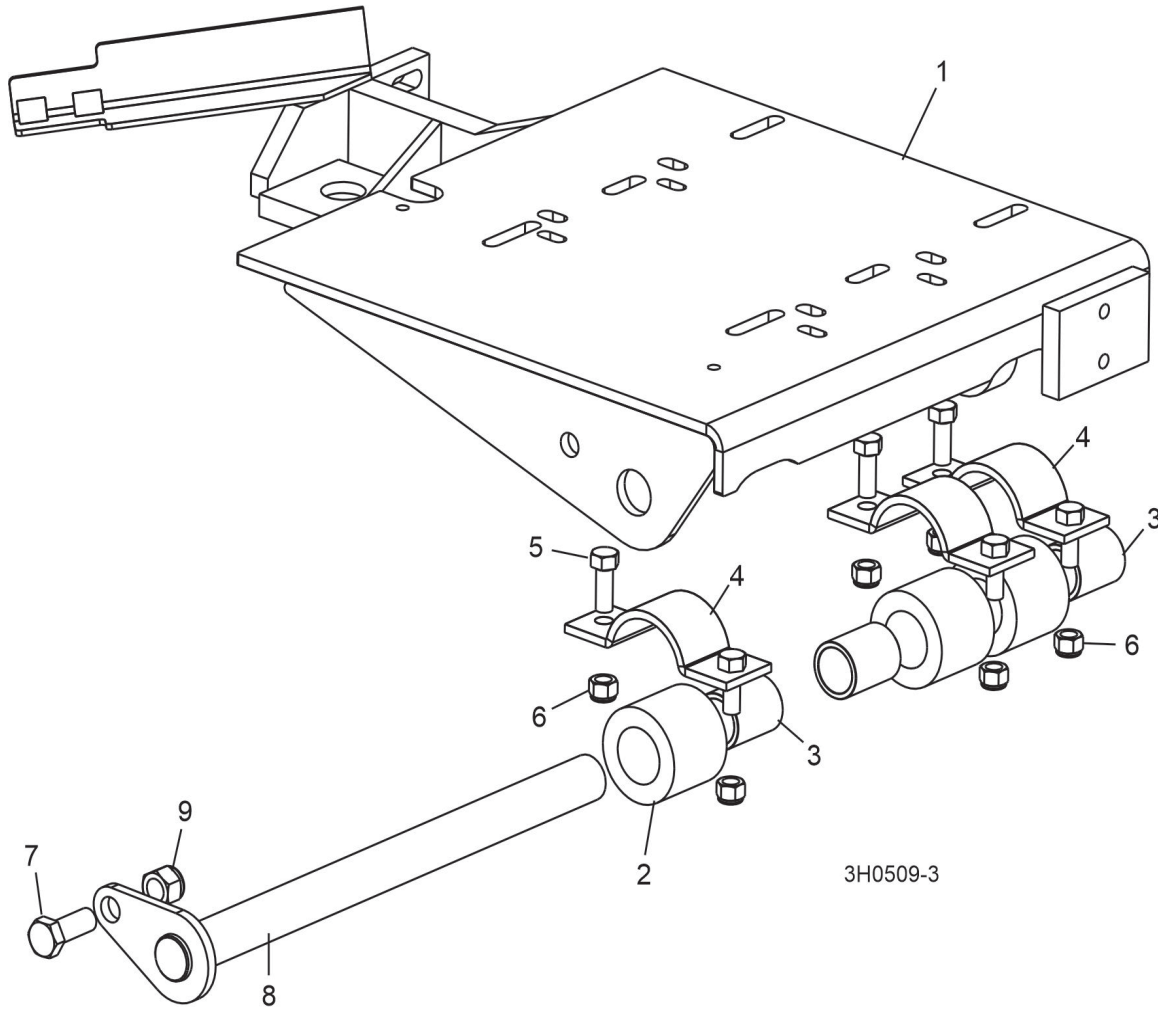

REF	PART #	DESCRIPTION	COMMENTS	QTY.
	016319	Mount Kit, Kohler Engine	Service Kit including bushings and hardware	1
<b>1</b>	014514	Mount Weldment, Kohler Engine	Available in assemblies only.	1
	016380	Bushing Assembly, Motor Mount		3
<b>2</b>	016378	Bushing, 2" OD x 2"	Available in assemblies only.	1
<b>3</b>	016379	Bearing, 1" x 1 1/4" x 2"	Available in assemblies only.	1
<b>4</b>	014540	Clamp Weldment, Motor Mount Pivot Bushing		3
<b>5</b>	F05007-7	Bolt, 3/8-16 X 1" Hex Head		3
<b>6</b>	F05010-10	Nut, 3/8-16 Hex Nylon Lock		6
<b>7</b>	F05008-37	Bolt, 1/2-13 X 1 1/4" Hex Head Grade 5		1
<b>8</b>	014154	Pin Weldment, Engine Mount Pivot		1
<b>9</b>	F05010-8	Nut, 1/2-13 Nylon Lock		1

## 4.5 Engine Assembly

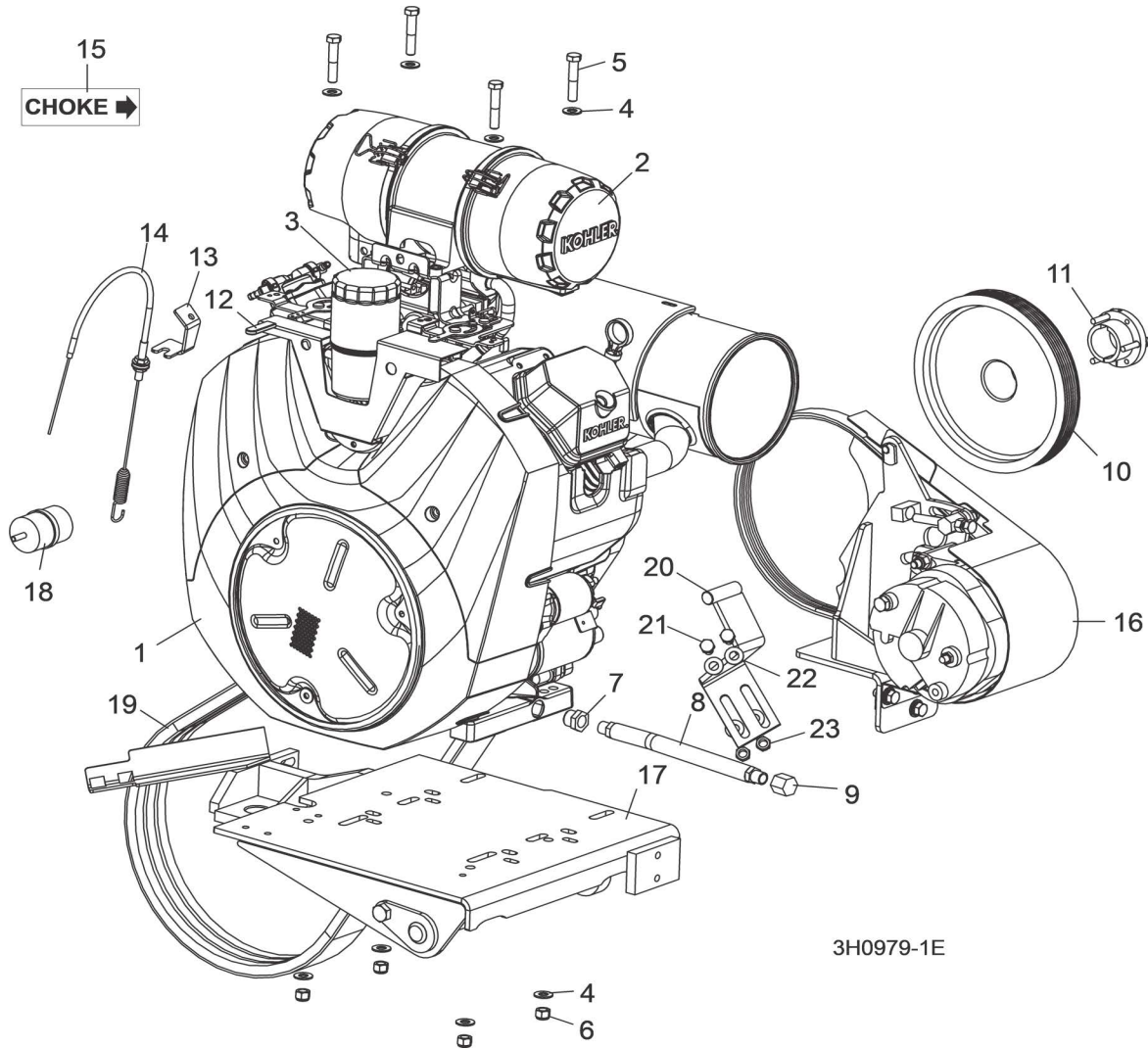

REF	PART #	DESCRIPTION	COMMENTS	QTY.
	CEG38	<b>COVER, G35 (G38) ENGINE</b>		1
	003200	<b>ENGINE ASSEMBLY, 35HP KOHLER</b>	Removed 003228 G35 (G38) Choke Indicator Bracket (5/15).	1
1	003199	Engine, 35Hp Kohler CH980-0010		1
2		Air Cleaner, Kohler 35HP (38HP)		1
	046553	Filter, Kohler Primary Air #25-083-01-S		1
	046554	Filter, Kohler Secondary Air #25-083-04-S		1
3	014717	Filter, Kohler Oil #52-050-02-S		1
	061371	Starter, Kohler Engine KH# 25 098 21S		1
	061003	Plug, Kohler G35 (G38) Spark #62-132-04-S		2
	061231	Pump Electric, Fuel G26 25 755 73-s	High Pressure Electrical Pump	1
	061156	Pump, Fuel #62-559-01S	Low Pressure Mechanical Pump	1
4	F05011-3	Washer, 3/8" SAE Flat		4
5	F05007-124	Bolt, 3/8-16 x 2" Hex Head Grade 5		4
6	F05010-10	Nut, 3/8-16 Hex Nylon Lock		4
7	003227	Fitting, 1/2" MPT x 3/8" FPT Reducer Bushing		1

# 4 Replacement Parts

Engine Assembly

REF	PART #	DESCRIPTION	COMMENTS	QTY.
8	P10082	Hose, 7" Oil Drain		1
9	P04332	Cap, Oil Drain 3/8" Pipe		1
10	003206	Pulley, 5V x 4.06" x 8.5" Poly-V		1
11	016535	Bushing, 1 7/16" SH		1
12	003229	Grip, 1/16" x 3/8" x 1 1/2" Black		1
13	003222	Bracket, Throttle Mount		1
14	034809	Cable Assembly, G35 (G38) Throttle		1
15	003230	Decal, Choke ID		1
16		Alternator Parts ( <a href="#">See Section 4.4</a> )		
17		Engine Mount Parts ( <a href="#">See Section 4.2</a> )		
18	P12758	<b>FILTER, KOHLER FUEL #24-050-13</b>	Kohler #24-050-13 9-12 micron filter replaces #240-050-10 8-10 micron filter originally supplied.	1
19	006672	<b>BELT, 3/5VL750 DRIVE</b>	Cog-style belt 006672 replaces 016556 originally supplied prior to 7/08 to reduce slippage.	1
20	015058	<b>BRACKET WDMT, CLUTCH ENHANCEMENT</b>		1
21	F05007-7	<b>BOLT, 3/8-16X1 HH</b>		2
22	F05011-3	<b>WASHER, #8 FLAT SAE</b>		4
23	F05010-10	<b>NUT, 3/8-16 HEX NYL LOCK</b>		2



## 4.6 Alternator Assembly

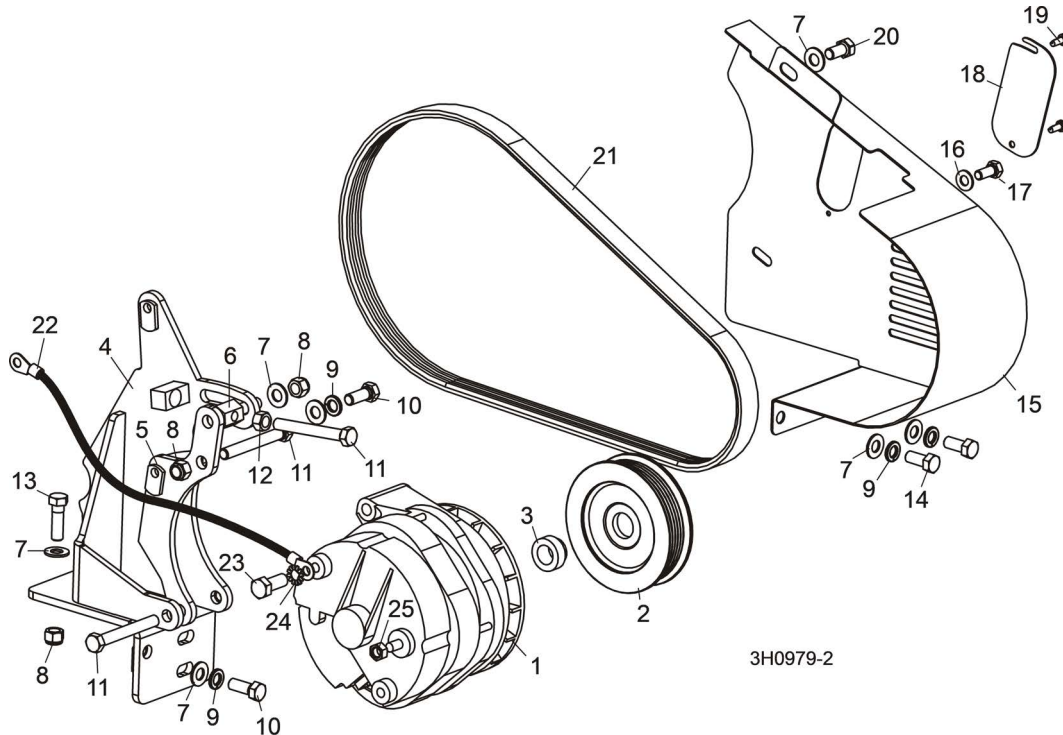

3H0979-2

REF	PART #	DESCRIPTION	COMMENTS	QTY.
	015969	Wire Assembly, 61/140 Amp Alternator Plug		1
	024308	Wire Assembly, Alternator to Starter		1
	023730	Alternator Assembly, 140 Amp		1
1	023695	Alternator, 140 Amp		1
	036572	Pulley Assembly, 140 Amp Alternator		1
2	023694	Pulley, 140 Amp Alternator	Available in assemblies only.	1
3	036571	Spacer, Alternator Pulley		1
4	003202	Bracket Weldment, Alternator Mounting		1
5	015875	Plate Weldment, Alternator Mount		1
6	023764	Stud, Alternator Belt Tension Adjustment		1
7	F05011-3	Washer, 3/8" SAE Flat		7
8	F05010-10	Nut, 3/8-16 Nylon Lock		3
9	F05011-4	Washer, 3/8" Split Lock		4
10	F05007-87	Bolt, 3/8-16 x 1" Hex Head Grade 5		2
11	F05007-1	Bolt, 3/8-16 x 3" Hex Head Full Thread		3
12	F05010-1	Nut, 3/8-16 Hex		1
13	F05007-123	Bolt, 3/8-16 x 1 1/4" Hex Head Grade 5		1
14	F05007-185	Bolt, 3/8-16 x 7/8" Hex Head Grade 5		2
15	003216	Guard Weldment, G35 (G38) Alternator		1
16	F05011-17	Washer, 5/16-18 SAE Flat		1
17	F05006-5	Bolt, 5/16-18 x 3/4" Hex Head		1
18	023794	Plate, Alternator Belt Access		1
19	F05015-17	Bolt, #10-24 x 1/2" Pan Head		2
20	F05007-27	Bolt, 3/8-16 x 3/4" Hex Head		1
21	023709	Belt, 6PK425 Fiberglass		1
22	017770	Wire Assembly, Ground Jumper		1
23	F05011-36	Washer, 3/8" External Star Lock		1

## 4 Replacement Parts

*Alternator Assembly*

---

REF	PART #	DESCRIPTION	COMMENTS	QTY.
24	F81003-11	Bolt, M10-1.5 x 25mm Hex Head Grade 8		1
25	F05010-76	Nut, M8-1.25 Hex		1

4.7 Engine Pulley Guards

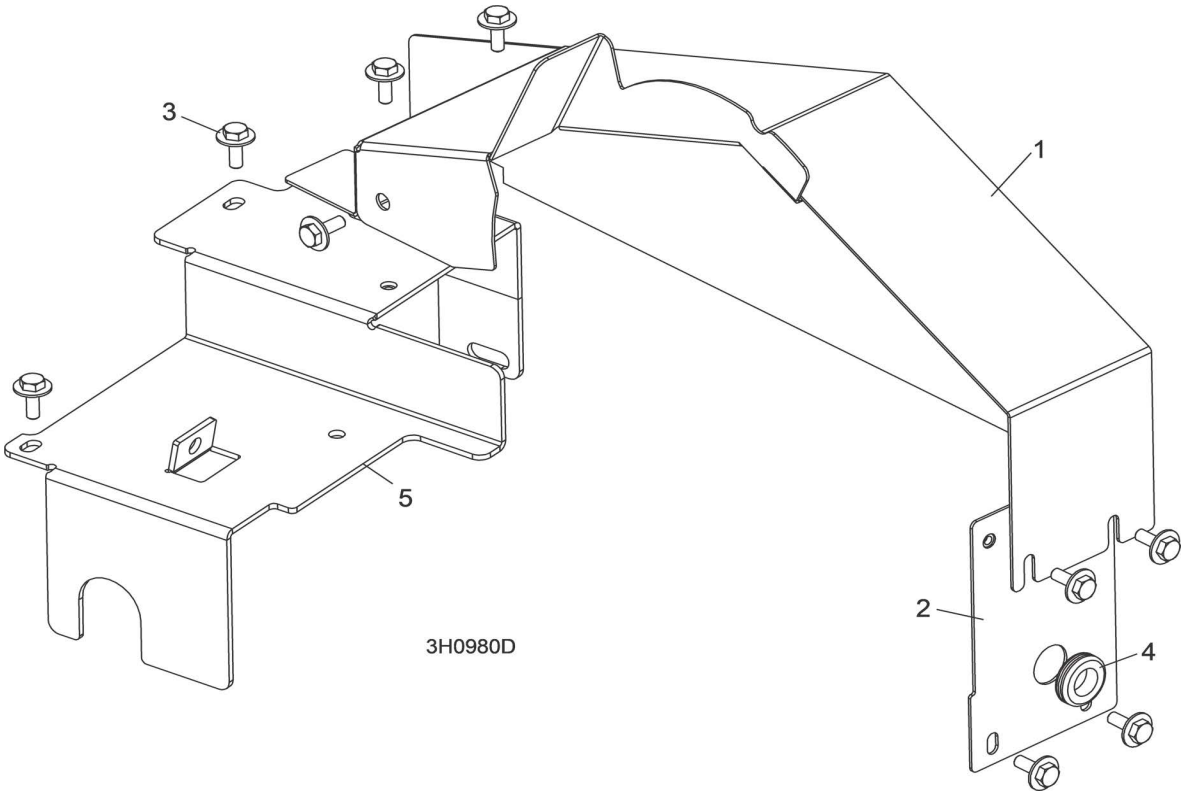

REF	PART #	DESCRIPTION	COMMENTS	QTY.
1	003220	Guard Weldment, G35 (G38) Engine Pulley		1
2	003263	Plate Weldment, G35 (G38) Engine Pulley Guard Mount		1
3	F05005-134	Bolt, 1/4-20 x 3/4" Hex Head With Conical Washer		9
4	P11764	Grommet, 5/8" ID Rubber		1
5	015962	Guard, Kohler Side Engine Pulley		1