

Wood-Mizer[®] Sawmill

Parts Manual

LT50HD

rev. A6.01

Safety is our #1 concern!

April 2023

Form #1299



WARNING! Read and understand this manual before using this machine.

California
Proposition 65 Warning



WARNING: Breathing gas/diesel engine exhaust exposes you to chemicals known to the State of California to cause cancer and birth defects or other reproductive harm.

- Always start and operate the engine in a well-ventilated area.
- If in an enclosed area, vent the exhaust to the outside.
- Do not modify or tamper with the exhaust system.
- Do not idle the engine except as necessary.

For more information go to **www.P65warnings.ca.gov**.



WARNING: Drilling, sawing, sanding or machining wood products can expose you to wood dust, a substance known to the State of California to cause cancer. Avoid inhaling wood dust or use a dust mask or other safeguards for personal protection.

For more information go to **www.P65Warnings.ca.gov/wood**.

Active Patents assigned to Wood-Mizer, LLC

Wood-Mizer, LLC has received patents that protect our inventions which are a result of a dedication to research, innovation, development, and design. Learn more at: woodmizer.com/patents

©2022 Wood-Mizer LLC

Printed in the United States of America, all rights reserved. No part of this manual may be reproduced in any form by any photographic, electronic, mechanical or other means or used in any information storage and retrieval system without written permission from

Wood-Mizer, LLC
8180 West 10th Street
Indianapolis, Indiana 46214

SECTION 1 REPLACEMENT PARTS

1.1 How To Use The Parts List..... 1-1
To Order Parts 1-1
 1.2 Sample Assembly..... 1-1

SECTION 2 BLADE GUIDE ROLLERS & ARM

2.1 Blade Guide Assembly, Idle Side 2-1
 2.2 Blade Guide Assembly, Drive Side 2-4
 2.3 Blade Guide Arm Drive Assembly 2-7
 2.4 Blade Guide Arm 2-9

SECTION 3 BLADE WHEELS & TENSIONER

3.1 Blade Drive Assembly 3-1
 3.2 Idle Blade Wheel Assembly..... 3-3
 3.3 Hydraulic Blade Tensioner Assembly 3-4

SECTION 4 SAW HEAD FRAME

4.1 Middle Throat Screw 4-1
 4.2 Water Lube Solenoid Valve..... 4-2
 4.3 Clutch Pivot..... 4-3
 4.4 Clutch Mount Assembly 4-4
 4.5 Brake Assembly 4-5
 4.6 Brake Assembly (DC Only)..... 4-6
 4.7 Board Return Assembly 4-7
 4.8 Water Lube Assembly (Gas Only)..... 4-9
 4.9 Water Lube Assembly (Diesel & Electric Only) 4-10
 4.10 Saw Head Decals 4-12
 4.11 Blade Housing Covers 4-13
 4.12 Drive Belt Covers..... 4-15
 4.13 Sawdust Chute..... 4-16
 4.14 Debarker Wire Box/Hole Plugs 4-17

SECTION 5 CONTROL & BATTERY BOXES

5.1 Control Assembly 5-1
 5.2 Control Assembly (Tier4 Only) 5-3
 5.3 Drum Switches..... 5-5
 5.4 Circuit Breakers 5-6
 5.5 Front Panel Assembly & Harnesses..... 5-7
 5.6 Front Panel Assembly & Harnesses (US Only) 5-9
 5.7 Battery Box Assembly 5-10
 5.8 Fuse Box Assembly 5-12

SECTION 6 UP/DOWN SYSTEM

6.1 Saw Head Mount..... 6-1
 6.2 Blade Height & Quarter Scales..... 6-2
 6.3 Up/Down Chain & Sprockets 6-4
 6.4 Up/Down Motor Assembly..... 6-5
 6.5 Up/Down Drive Assembly..... 6-6

SECTION 7 FEED SYSTEM & TRACK ROLLERS

7.1 Upper Track Rollers And Wipers.....7-1
 7.2 Power Feed Assembly7-2
 7.3 Feed Chain/Stop7-4
 7.4 Lower Track Rollers.....7-5

SECTION 8 BED FRAME ASSEMBLY

8.1 Bed Rail Assembly, Front And Rear8-1
 8.2 Bed Rail Assembly, Middle Front.....8-3
 8.3 Bed Rail Assembly, Middle Rear8-4
 8.4 Fine Adjustable Legs Overview8-5
 8.5 FAO Outrigger, Front8-6
 8.6 FAO Outrigger, Loading Side8-7
 8.7 FAO Outrigger, Offset Leg8-8
 8.8 FAO Outrigger, Rear8-9
 8.9 Board Return Table Assembly8-10
 8.10 Pivot Bed Rail Assembly.....8-11
 8.11 Safety Chain Assembly8-12
 8.12 Saw Head Rest Pin Assembly8-13
 8.13 Bed Frame Decals.....8-14
 8.14 Board Outfeed Table (Optional)8-15

SECTION 9 BED HYDRAULIC SYSTEM

9.1 Hydraulic Hoses9-1
 9.2 Hydraulic Control Box9-2
 9.3 Hydraulic Power Supply Strip.....9-5
 9.4 Hydraulic Log Loader9-7
 9.5 Hydraulic Log Turner.....9-9
 9.6 Hydraulic Log Side Supports (Front).....9-11
 9.7 Hydraulic Log Side Supports (Rear)9-13
 9.8 Hydraulic Log Side Supports (Link)9-15
 9.9 Hydraulic Log Clamp9-16
 9.10 Hydraulic Toe Board9-18

SECTION 10 MISCELLANEOUS

10.1 Replacement Manuals10-1

SECTION 1 REPLACEMENT PARTS

1.1 How To Use The Parts List

- Use the table of contents to locate the assembly that contains the part you need.
- Go to the appropriate section and locate the part in the illustration.
- Use the number pointing to the part to locate the correct part number and description in the table.
- Parts shown indented under another part are included with that part.

To Order Parts

- From the continental US, call **1-800-525-8100** to order parts. Have your customer number, vehicle identification number, and part numbers ready when you call.
- From other international locations, contact the Wood-Mizer distributor in your area for parts.

1.2 Sample Assembly

REF	PART #	DESCRIPTION	COMMENTS	QTY.
	012345	SAMPLE ASSEMBLY, COMPLETE	INCLUDES ITEMS 1-6	1
1	F02222-22	Sample Part		1
2	F03333-33	Sample Part		2
	098765	Sample Subassembly	Includes items 3-6	1
3	S04444-44	Subassembly Sample Part		1
4	K55555	Subassembly Sample Part		1
	054321	Sample Sub-Subassembly	Includes items 5-6	2
5	022222	Sub-Subassembly Sample Part		1
6	F10234-56	Sub-Subassembly Sample Part		1

The Sample Assembly, Complete, part number 012345 (top level assembly) includes two parts (F0222-22 and F0333-33) and the 098765 subassembly.

Subassembly 098765 contains two parts(S04444-44 and K55555) and two copies of sub-subassembly 054321.

Each sub-subassembly 054321 contains two parts (022222 and F10234-56).

SECTION 2 BLADE GUIDE ROLLERS & ARM

2.1 Blade Guide Assembly, Idle Side

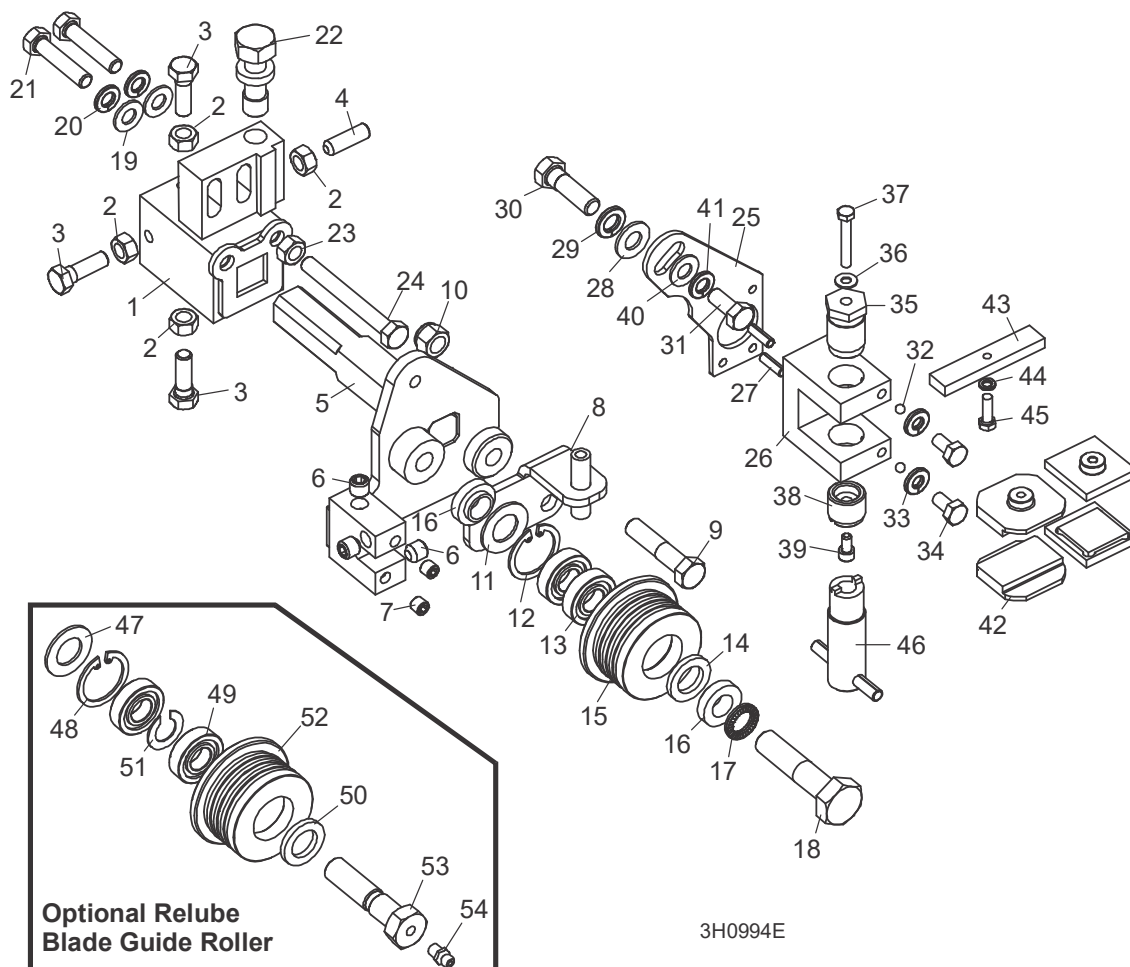

REF	PART #	DESCRIPTION	COMMENTS	QTY.
	003992	GUIDE ASSEMBLY, IDLE SIDE BLADE ROLLER		1
	003920	Block Assembly, Idle Side Blade Guide Mount		1
1	003921	Block Weldment, Blade Guide Mount	Available in assemblies only.	1
2	F05010-17	Nut, 5/16-18 Hex		4
3	F05006-88	Bolt, 5/16-18 x 1" Hex Head Stainless Steel		3
4	F05006-122	Screw, 5/16-18 x 1" Socket Head Flat Point Stainless Steel Set		1
5	003924	Shaft Weldment, Idle Side Guide		1
6	P30127	Fitting, 1/8" NPT Socket Pipe Plug		3
7	007734	Fitting, 1/16" NPT Socket Pipe Plug		2
8	006322	Bracket Weldment, Idle Side Water Lube		1
9	F05007-78	Bolt, 3/8-16x1 1/2 Hex Head Grade 5		1
10	F05010-10	Nut, 3/8-16 Hex Nylon Lock		1

REF	PART #	DESCRIPTION	COMMENTS	QTY.
	A04925	Roller Assembly, Blade Guide (standard for use with 1 1/4" & 1 1/2" blades)	Use kit 006382 to convert rollers and guide blocks for both blade guides for 1 1/2" blades. Optional relube versions of each roller configuration also available.	1
	014299	Roller Assembly, Extended Blade Guide (optional for use with 1 1/2" blades)		1
	K07079	Bearing Kit, Blade Guide Rebuild		1
11	P04252	Washer, 5/8" White Felt		1
12	F04254-1	Ring, 1 1/8" Interior Retaining		1
13	015975	Bearing, R8-2RS Blade Guide	Available in assemblies only.	2
14	P06455	Washer, 5/8" Gray Felt		1
	F05005-105	Screw, 1/4-28 x 1/4" Socket Head Cup Point Set Black Oxide		1
	057407-1507	Instruction Sheet, Blade Guide Rebuild		1
15	S04250	Roller, Flanged Blade Guide (1 1/4" & 1 1/2" blade)	Available in assemblies only.	1
	014298	Roller, Flanged Blade Guide (1 1/2" blade)	Available in assemblies only.	1
	A04925-364	Instruction Sheet, Blade Guide Roller Replacement		1
16	S04253	Spacer, Blade Guide		2
17	F05011-125	Washer, 1/2" Nord-Lock		1
18	F05008-10	Bolt, 1/2-13 x 2 1/4" Hex Head Grade 5		1
19	F05011-17	Washer, 5/16" SAE Flat		2
20	F05011-13	Washer, 5/16" Split Lock		2
21	F05006-76	Bolt, 5/16-18 x 1 1/2" Hex Head		2
22	035656	Bolt, Blade Guide Vertical Adjustment		1
23	F05010-17	Nut, 5/16-18 Hex		1
24	F05006-136	Bolt, 5/16-18 x 2 3/4" Hex Head Full Thread		1
	006325	GUIDE KIT, HIGH-PERFORMANCE BLADE GUIDE (OPTIONAL)	High-Performance Blade Guide Kit requires LMS blade lube system. If sawmill not already equipped with LMS, add kit .	1
	003928	Block Assembly, Idle Side Blade Guide		1
25	003915	Plate, Block Tilt Adjustment		1
26	003909	Block, Guide Block Mount		1
27	F05012-22	Pin, 3/16" x 5/8" Roll		2
28	F05011-3	Washer, 3/8" SAE Flat		1
29	F05011-4	Washer, 3/8" Split Lock		1
30	F05007-123	Bolt, 3/8-16 x 1 1/4" Hex Head Grade 5		1
31	F05006-102	Bolt, 5/16-18 x 3/4" Hex Head		1
32	003914	Ball, 3/16" Dia. Nylon		2
33	F05011-14	Washer, 1/4" Split Lock		2
34	F05005-15	Bolt, 1/4-20 x 1/2" Hex Head		2
35	003994	Bolt, Blade Guide Block Mount		1
36	042867	Washer, #10 Brass		1
37	F05004-240	Bolt, #10-32 x 1 1/4" Hex Head Stainless Steel		1
38	044057	Screw, Lower Block Adjustment		1
39	F05004-200	Screw, #10-32 x 3/8" Socket Head Stainless Steel		1
40	F05011-17	Washer, 5/16" SAE Flat		1

2 Blade Guide Rollers & Arm

Blade Guide Assembly, Idle Side

REF	PART #	DESCRIPTION	COMMENTS	QTY.
41	F05011-13	Washer, 5/16" Split Lock		1
42	052355	Block, Blade Guide Wear (Standard for 1 1/4" Blades)	Use kit 006382 to convert rollers and guide blocks for both blade guides for 1 1/2" blades. EZ-Glide blocks 036347 are available.	2
	052309	Block, Blade Guide Wear (Optional for 1 1/2" Blades)		2
	036347	Block Assembly, 1" Sq. EZ-Glide Wear		2
43	035799	Block, Blade Guide Alignment		1
44	F05011-20	Washer, #10 Split Lock		1
45	F05004-152	Screw, #10-32 x 5/8" Hex Head		1
46	044064	Adjustment Tool, Lower Guide Block		1
	035248	Shim, .008" Blade Guide Block Spacer		1
		Drive Side Blade Guide Parts	(See Section 2.1)	
	016568	ROLLER ASSEMBLY, BLADE GUIDE RELUBE	(OPTIONAL FOR USE WITH 1 1/4" OR 1 1/2" BLADES)	1
	057405	ROLLER ASSEMBLY, EXTENDED BLADE GUIDE RELUBE	(OPTIONAL FOR USE WITH 1 1/2" BLADES)	1
	057407	Bearing Kit, Relube Blade Guide Rebuild		1
47	P04252	Washer, 5/8" White Felt		1
48	F04254-1	Ring, 1 1/8" Interior Retaining		1
49	015975	Bearing, R8-2RS Blade Guide	Available in assemblies only. Bearing must be modified for use with relube roller assemblies. Remove (1) seal from each bearing, place open sides facing each other and place spacer 035411 between bearings.	2
50	P06455	Washer, 5/8" Gray Felt		1
51	035411	Spacer, Blade Guide Bearing		1
	057407-1507	Instruction Sheet, Blade Guide Rebuild		1
52	035426	Roller, Flanged Blade Guide (Relube 1 1/4" & 1 1/2" blade)	Available in assemblies only.	1
	057402	Roller, Flanged Blade Guide (Relube 1 1/2" blade)	Available in assemblies only.	1
	A04925-364	Instruction Sheet, Blade Guide Roller Replacement		1
53	036161	BOLT, BLADE GUIDE ROLLER (RELUBE ONLY)		1
54	P05060	FITTING, 1/4-28 GREASE (RELUBE ONLY)		1

2.2 Blade Guide Assembly, Drive Side

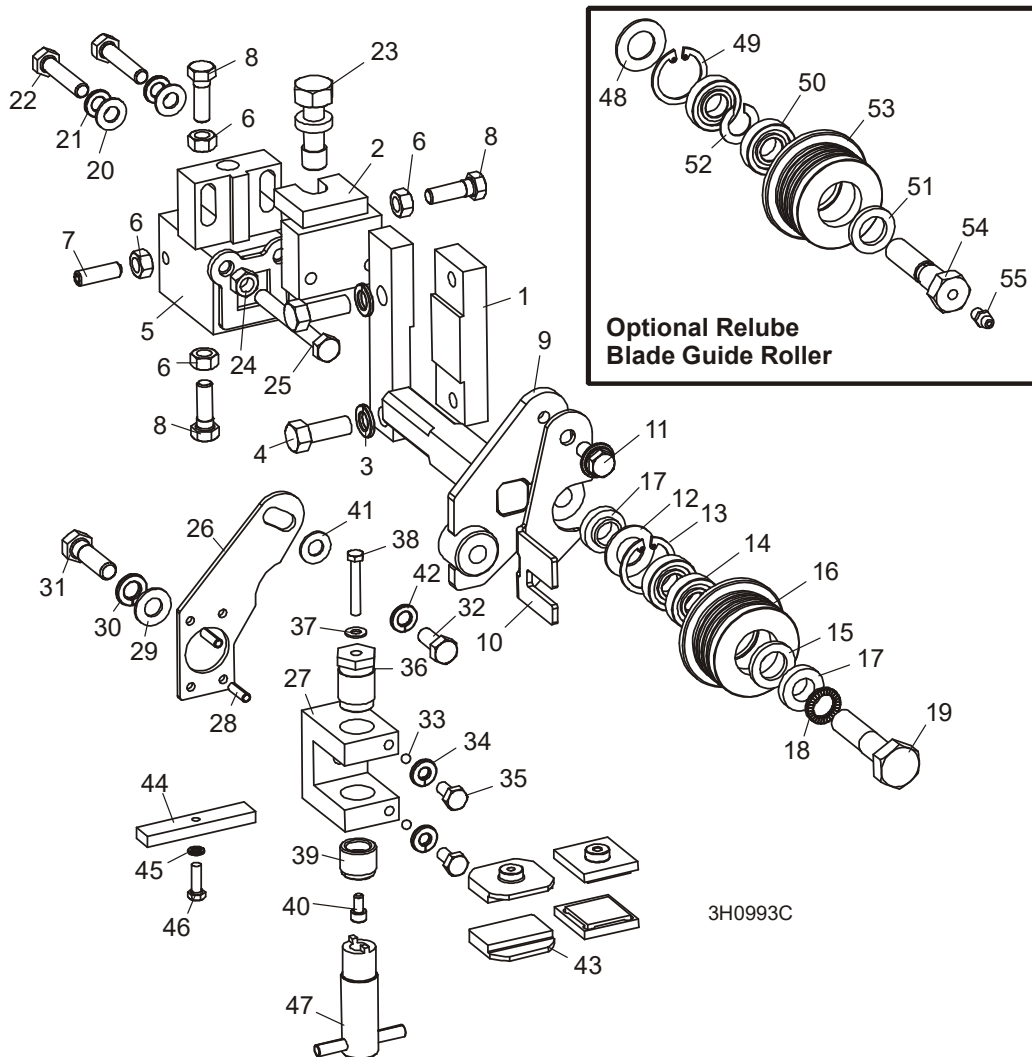

REF	PART #	DESCRIPTION	COMMENTS	QTY.
1	016548	BLOCK, BOLT ON BLADE GUIDE MOUNT		1
2	003964	BRACKET WELDMENT, INNER BLADE GUIDE MOUNT		1
3	F05011-4	WASHER, 3/8" SPLIT LOCK		2
4	F05007-7	BOLT, 3/8-16 X 1" HEX HEAD		2
	003905	GUIDE ASSEMBLY, DRIVE SIDE BLADE ROLLER		1
	003910	Block Assembly, Blade Guide Mount		1
5	003911	Block Weldment, Blade Guide Mount	Available in assemblies only.	1
6	F05010-17	Nut, 5/16-18 Hex		4
7	F05006-122	Screw, 5/16-18 x 1" Socket Head Flat Point Stainless Steel Set		1
8	F05006-88	Bolt, 5/16-18 x 1" Hex Head Stainless Steel		3
9	003913	Shaft Weldment, Drive Side Guide		1
10	003916	Plate, Blade Guide Deflector		1
11	F05006-101	Bolt, 5/16-18 x 3/4" Hex Head w/Flat & Lock Washer		1

2 Blade Guide Rollers & Arm

Blade Guide Assembly, Drive Side

REF	PART #	DESCRIPTION	COMMENTS	QTY.
	A04925	Roller Assembly, Blade Guide (standard for use with 1 1/4" & 1 1/2" blades)	Use kit 006382 to convert the rollers and guide blocks for both blade guides for 1 1/2" blades. Optional relube versions of each roller configuration are also available.	1
	014299	Roller Assembly, Extended Blade Guide (optional for use with 1 1/2" blades)		1
	K07079	Bearing Kit, Blade Guide Rebuild		1
12	P04252	Washer, 5/8" White Felt		1
13	F04254-1	Ring, 1 1/8" Interior Retaining		1
14	015975	Bearing, R8-2RS Blade Guide	Available in assemblies only.	2
15	P06455	Washer, 5/8" Gray Felt		1
	F05005-105	Screw, 1/4-28 x 1/4" Socket Head Cup Point Set Black Oxide		1
	057407-1507	Instruction Sheet, Blade Guide Rebuild		1
16	S04250	Roller, Flanged Blade Guide (1 1/4" & 1 1/2" blade)	Available in assemblies only.	1
	014298	Roller, Flanged Blade Guide (1 1/2" blade)	Available in assemblies only.	1
	A04925-364	Instruction Sheet, Blade Guide Roller Replacement		1
17	S04253	Spacer, Blade Guide		2
18	F05011-125	Washer, 1/2" Nord-Lock		1
19	F05008-10	Bolt, 1/2-13 x 2 1/4" Hex Head Grade 5		1
20	F05011-17	Washer, 5/16" SAE Flat		2
21	F05011-13	Washer, 5/16" Split Lock		2
22	F05006-93	Bolt, 5/16-18 x 1 1/4" Hex Head		2
23	035656	Bolt, Blade Guide Vertical Adjustment		1
24	F05010-17	Nut, 5/16-18 Hex		1
25	F05006-136	Bolt, 5/16-18 x 2 3/4" Hex Head Full Thread		1
	006325	GUIDE KIT, HIGH-PERFORMANCE BLADE GUIDE (OPTIONAL)	Requires LMS blade lube system. Use kit 006325 to upgrade to High-Performance. If not already equipped add LMS kit.	1
	003927	Block Assembly, Drive Side Blade Guide		1
26	003915	Plate, Block Tilt Adjustment		1
27	003909	Block, Guide Block Mount		1
28	F05012-22	Pin, 3/16" x 5/8" Roll		2
29	F05011-3	Washer, 3/8" SAE Flat		1
30	F05011-4	Washer, 3/8" Split Lock		1
31	F05007-123	Bolt, 3/8-16 x 1 1/4" Hex Head Grade 5		1
32	F05006-102	Bolt, 5/16-18 x 3/4" Hex Head		1
33	003914	Ball, 3/16" Dia. Nylon		2
34	F05011-14	Washer, 1/4" Split Lock		2
35	F05005-15	Bolt, 1/4-20 x 1/2" Hex Head		2
36	003994	Bolt, Blade Guide Block Mount		1
37	042867	Washer, #10 Brass		1
38	F05004-240	Bolt, #10-32 x 1 1/4" Hex Head Stainless Steel		1
39	044057	Screw, Lower Block Adjustment		1
40	F05004-200	Screw, #10-32 x 3/8" Socket Head Stainless Steel		1
41	F05011-17	Washer, 5/16" SAE Flat		1

REF	PART #	DESCRIPTION	COMMENTS	QTY.
42	F05011-13	Washer, 5/16" Split Lock		1
43	052355	Block, Blade Guide Wear (Standard for 1 1/4" Blades)	Use kit 006382 to convert the rollers and guide blocks for both blade guides for 1 1/2" blades. Optional relube versions of each roller configuration are also available.	2
	052309	Block, Blade Guide Wear (Optional for 1 1/2" Blades)		2
	036347	Block Assembly, 1" Sq. EZ-Glide Wear		2
44	035799	Block, Blade Guide Alignment		1
45	F05011-20	Washer, #10 Split Lock		1
46	F05004-152	Screw, #10-32 x 5/8" Hex Head		1
47	044064	Adjustment Tool, Lower Guide Block		1
	035248	Shim, .008" Blade Guide Block Spacer		1
		Idle Side Blade Guide Parts	(See Section 2.1)	
	016568	ROLLER ASSEMBLY, BLADE GUIDE RELUBE (OPTIONAL FOR USE WITH 1 1/4" OR 1 1/2" BLADES)	Use kit 006382 to convert the rollers and guide blocks for both blade guides for 1 1/2" blades. Optional relube versions of each roller configuration are also available.	1
	057405	ROLLER ASSEMBLY, EXTENDED BLADE GUIDE RELUBE (OPTIONAL FOR USE WITH 1 1/2" BLADES)		1
	057407	Bearing Kit, Relube Blade Guide Rebuild		1
48	P04252	Washer, 5/8" White Felt		1
49	F04254-1	Ring, 1 1/8" Interior Retaining		1
50	015975	Bearing, R8-2RS Blade Guide	Available in assemblies only. Bearing must be modified for use with relube roller assemblies. Remove one seal from each bearing, place open sides facing each other and place spacer 035411 between bearings.	2
51	P06455	Washer, 5/8" Gray Felt		1
52	035411	Spacer, Blade Guide Bearing		1
	057407-1507	Instruction Sheet, Blade Guide Rebuild		1
53	035426	Roller, Flanged Blade Guide (Relube 1 1/4" & 1 1/2" blade)	Available in assemblies only.	1
	057402	Roller, Flanged Blade Guide (Relube 1 1/2" blade)	Available in assemblies only.	1
	A04925-364	Instruction Sheet, Blade Guide Roller Replacement		1
54	036161	BOLT, BLADE GUIDE ROLLER (RELUBE ONLY)		1
55	P05060	FITTING, 1/4-28 GREASE (RELUBE ONLY)		1

2.3 Blade Guide Arm Drive Assembly

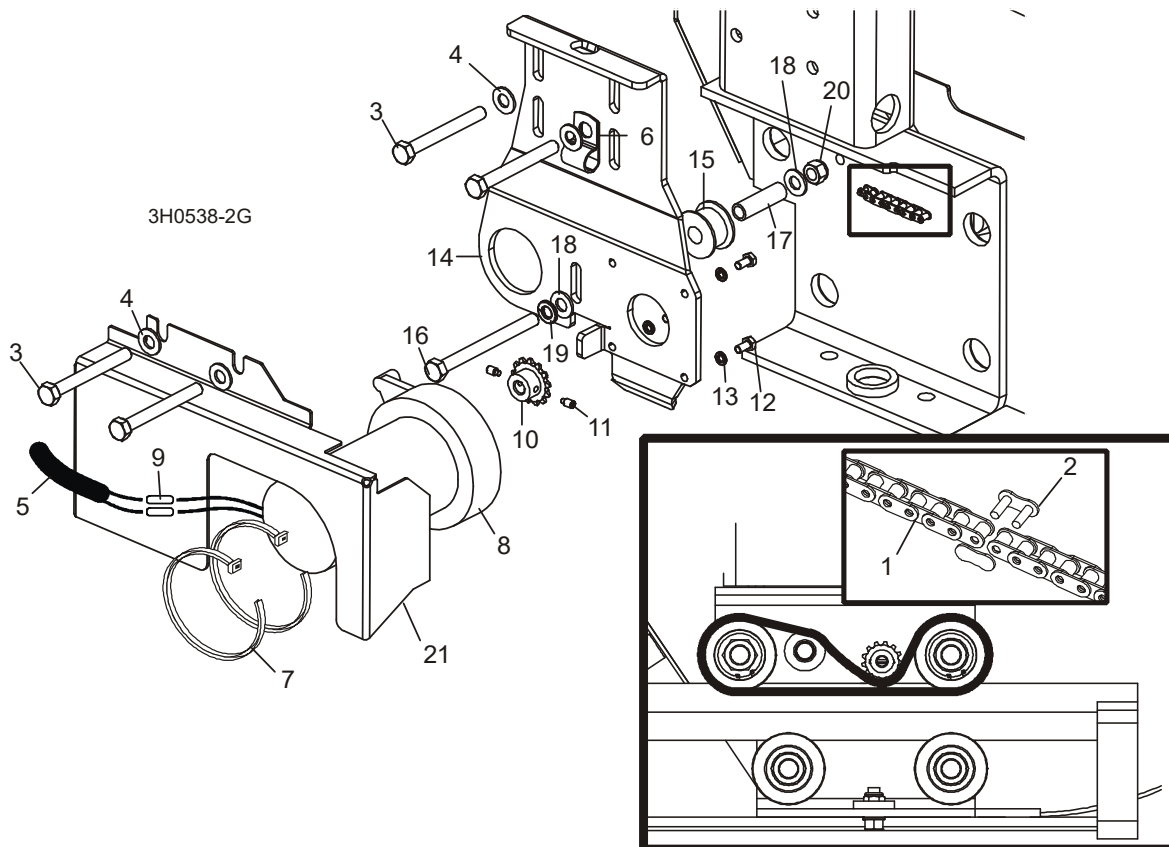

REF	PART #	DESCRIPTION	COMMENTS	QTY.
1	P09984	CHAIN, #25 X 20 1/4"		1
2	P09983	LINK, #25 MASTER		1
3	F05006-28	BOLT, 5/16-18 X 2 3/4" HEX HEAD GRADE 5		4
4	F05011-17	WASHER, 5/16" SAE FLAT		4
5	R01897	TUBE, 3/8" X 1/2" NEOPRENE		2.5ft
6	P07584	CLAMP, 1/2" COATED EMT		2
7	F05089-1	WRAP, 1/4" X 6" TIE		2
	015989	DRIVE ASSEMBLY, BLADE GUIDE ARM		1
	079215	Motor Assembly, Blade Guide Arm Replacement		1
8	079214	Motor, Current Applications 1/30HP 12VDC Gear		1
	061232	Gear Kit, Motor Replacement (Current Application)		1
	061234	Brush Kit, Gear Motor Replacement (Current Application)		1
	061233	Shaft Kit, Gear Motor Replacement (Current Application)		1
9	F04875-1	Connector, 14 Gauge Butt		2
10	P09970	Sprocket, Gear Motor #25 14-Tooth		1
11	F05004-274	Screw, #10-24 x 1/4" Full Dog Point Socket Set		2
12	F05004-60	Screw, #10-32 x 1/2" Hex Head		4
13	F05011-20	Washer, #10 Split Lock		4
	A10365-296	Instruction Sheet, Blade Guide Arm Motor		1

REF	PART #	DESCRIPTION	COMMENTS	QTY.
14	015939	Bracket, Blade Guide Arm Motor Mount		1
15	S09999	Roller, Blade Guide Arm Chain Idler		1
16	F05006-3	Bolt, 5/16-18 X 3 1/2" Hex Head Full Thread		1
17	S09996	Spacer, 5/16" I.D. X 1 1/2"		1
18	F05011-17	Washer, 5/16" SAE Flat		2
19	F05011-13	Washer, 5/16" Split Lock		1
20	F05010-58	Nut, 5/16-18 Hex Nylon Lock		1
21	S11617	COVER, BLADE GUIDE ARM MOTOR		1
	S12029	GUARD, BLADE GUIDE ARM (G.S. ONLY)		1

2.4 Blade Guide Arm

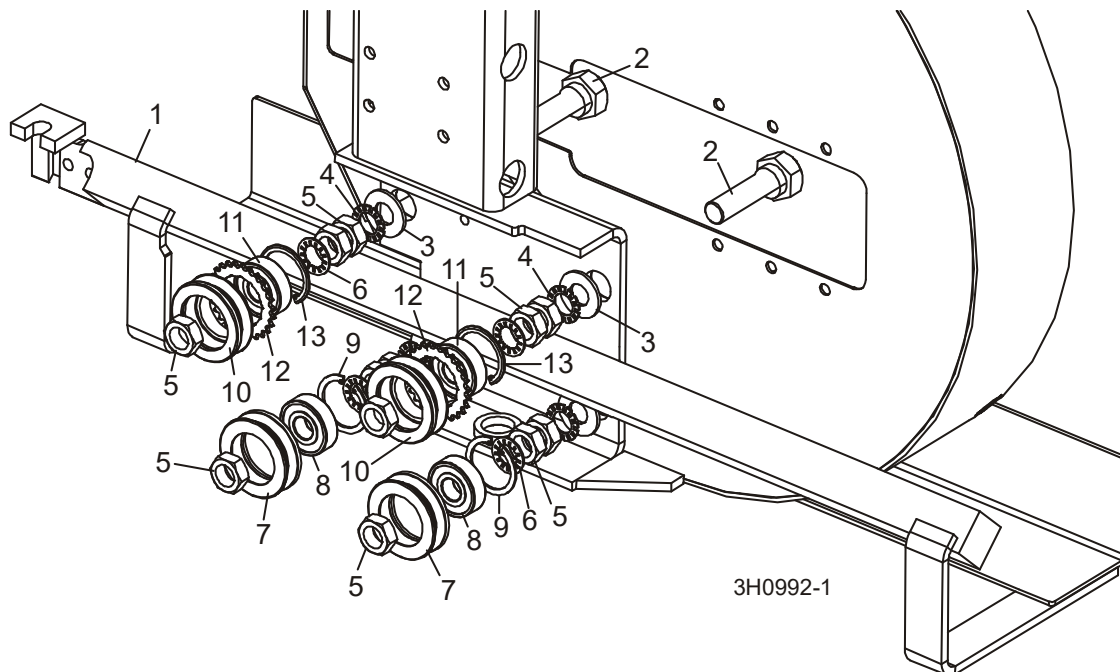

REF	PART #	DESCRIPTION	COMMENTS	QTY.
1	003972	BLADE GUIDE ARM WELDMENT		1
	007040	BLADE GUIDE ARM WELDMENT (WIDE HEAD ONLY)		1
2	W09067	BOLT, BLADE GUIDE ARM ROLLER CAM		4
3	F05011-5	WASHER, 5/8" SAE FLAT		4
4	F05011-26	WASHER, 5/8" EXTERNAL STAR		4
5	F05010-11	NUT, 5/8-18 HEX JAM		12
6	F05011-25	WASHER, 5/8" INTERNAL STAR		8
	A09059	ROLLER ASSEMBLY, BLADE GUIDE ARM WITH BEARING		2
7	S07989	Roller, Blade Guide Arm V-Groove	Available in assemblies only.	1
8	P06030-1	Bearing, 6203-2NSL 5/8" I.D.	Available in assemblies only.	1
9	F04254-8	Ring, 1.575" ID Beveled 5002-156 Retaining		1
	A09932	ROLLER ASSEMBLY, BLADE GUIDE ARM WITH BEARING AND SPROCKET		2
10	S09930	Roller, Blade Guide Arm Drive	Available in assemblies only.	1
11	P06030-1	Bearing, 6203-2NSL 5/8" I.D.	Available in assemblies only.	1
12	S09931	Sprocket, #25 26-Tooth	Available in assemblies only.	1
13	F04254-8	Ring, 1.575" ID Beveled 5002-156 Retaining		1

SECTION 3 BLADE WHEELS & TENSIONER

3.1 Blade Drive Assembly

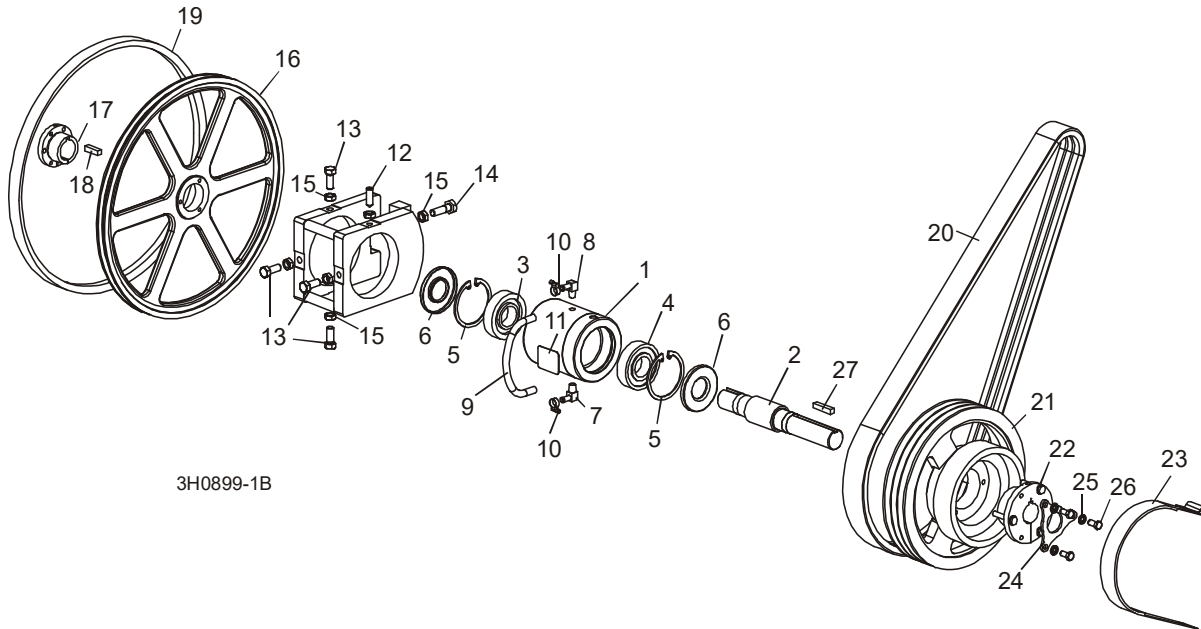

REF	PART #	DESCRIPTION	COMMENTS	QTY.
	016393	BEARING ASSEMBLY, BLADE WHEEL DRIVE		1
	016392	Bearing Assembly, Cylindrical Drive	Available in assemblies only.	1
1	016391	Housing, Blade Wheel Drive Bearing	Available in assemblies only.	1
2	014005	Shaft, Blade Wheel Drive	Available in assemblies only.	1
3	P10205	Bearing, Blade Wheel Drive #MU1308TV		1
4	016055	Bearing, Blade Wheel Drive #6308 C3 Open		1
5	F04254-17	Ring, 90mm Interior Retaining #117		2
6	P10206	Seal, Drive Bearing #CR15890		2
7	016330	Fitting, 1/4" NPT x 3/8" Hose Barb Elbow		1
8	016331	Fitting, 1/4" NPT x 3/8" Hose Barb Vented Elbow		1
9	016394	Hose, Oil Level Viewer		1
10	P649	Clamp, 7/32-5/8" Hose		2
11	017470	Decal, Oil Level Gauge		1
	016393-555	Instruction Sheet, Drive Bearing Replacement		1
12	F05004-170	SCREW, 1/2-20 X 1 1/2" CONE POINT SET		1
13	F05008-108	BOLT, 1/2-20 X 1 1/4" HEX HEAD GRADE 5		4
14	F05008-49	BOLT, 1/2-20 X 1 3/4" HEX HEAD GRADE 5		1
15	F05010-16	NUT, 1/2-20 HEX JAM		6
	014562	WHEEL KIT, DRIVE SIDE BLADE		1
16	016284	Wheel, Drive Side Blade	Available in assemblies only.	1
17	016270	Bushing, Modified 1 9/16" SD		1
18	S12892	Key, 3/8" x 3/8" x 1 5/8"		1

REF	PART #	DESCRIPTION	COMMENTS	QTY.
	K12897-488	Instruction Sheet, Drive Side Blade Wheel Replacement		1
19	P04185	BELT, BLADE WHEEL B57		1
20		BELT, DRIVE	(See Section 5) FOR PART #	
21	016531	SHEAVE, 5V12.5X3 BRAKE COMBO		1
22	016532	BUSHING, SF X 1 9/16"		1
23	014391	STRAP, METAL-BACKED BRAKE		1
24	017953	PLATE, BUSHING KEY RETAINER		1
25	F05011-4	WASHER, 3/8" SPLIT LOCK		3
26	F05007-27	BOLT, 3/8-16 X 3/4" HEX HEAD		3
27	014693	KEY, 3/8" X 3/8" X 1 7/8"		1

3.2 Idle Blade Wheel Assembly

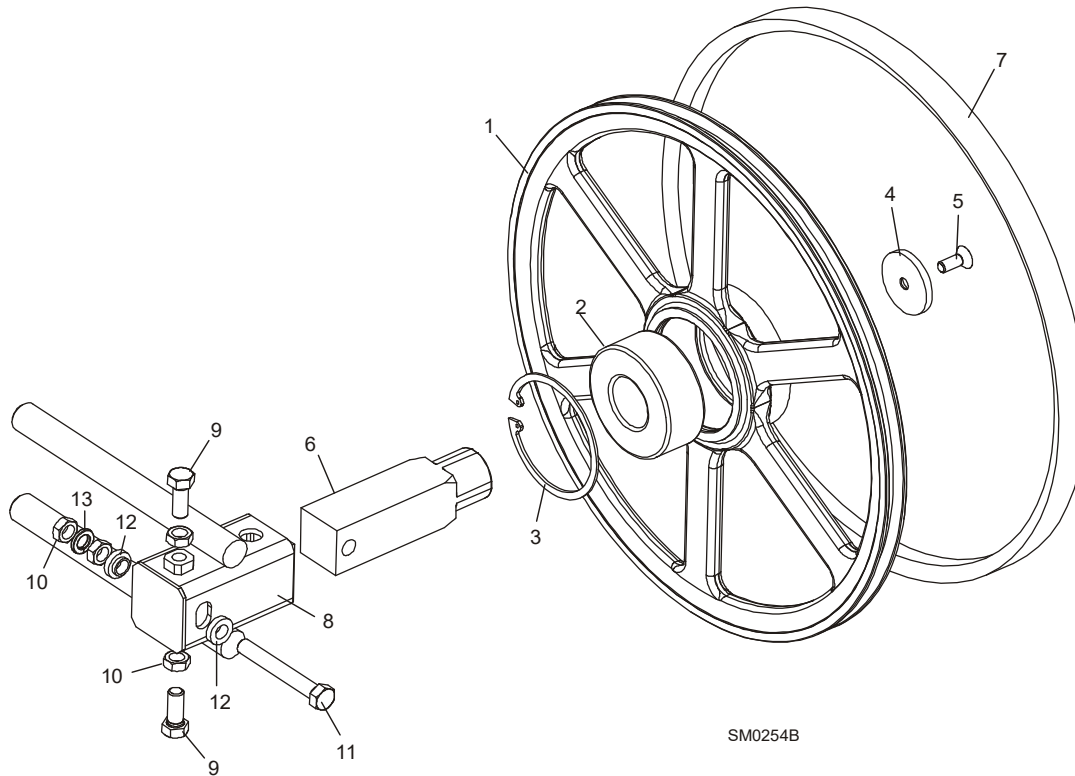

REF	PART #	DESCRIPTION	COMMENTS	QTY.
	016120	WHEEL ASSEMBLY, IDLE SIDE BLADE		1
1	016013	Wheel, Idle Side Blade	Available in assemblies only.	1
2	016014	Bearing, Idle Side Blade Wheel #5309-2RS, C3, SRI-2 Grease		1
3	F04254-28	Ring, 100mm Internal Retaining Beveled		1
	016441	SHAFT KIT, IDLE BLADE WHEEL		1
4	016397	Washer, 13/32" I.D. x 2 3/16 O.D. x 1/4"		1
5	F05007-64	Bolt, 3/8-16 x 1" Flat Head Socket		1
6	016398	Shaft, Idle Side Blade Wheel		1
7	P04185	BELT, BLADE WHEEL B57		1
8	016103	HOUSING, IDLE BLADE WHEEL SHAFT		1
9	F05008-53	BOLT, 1/2-20 X 1 1/2" HEX HEAD GRADE 5		2
10	F05010-16	NUT, 1/2-20 HEX JAM		4
11	F05008-111	BOLT, 1/2-20 X 3 3/4" HEX HEAD FULL THREAD GRADE 2		1
12	S04253	SPACER, 1/2" I.D. FLANGED		2
13	F05011-9	WASHER, 1/2" SPLIT LOCK		1

3.3 Hydraulic Blade Tensioner Assembly

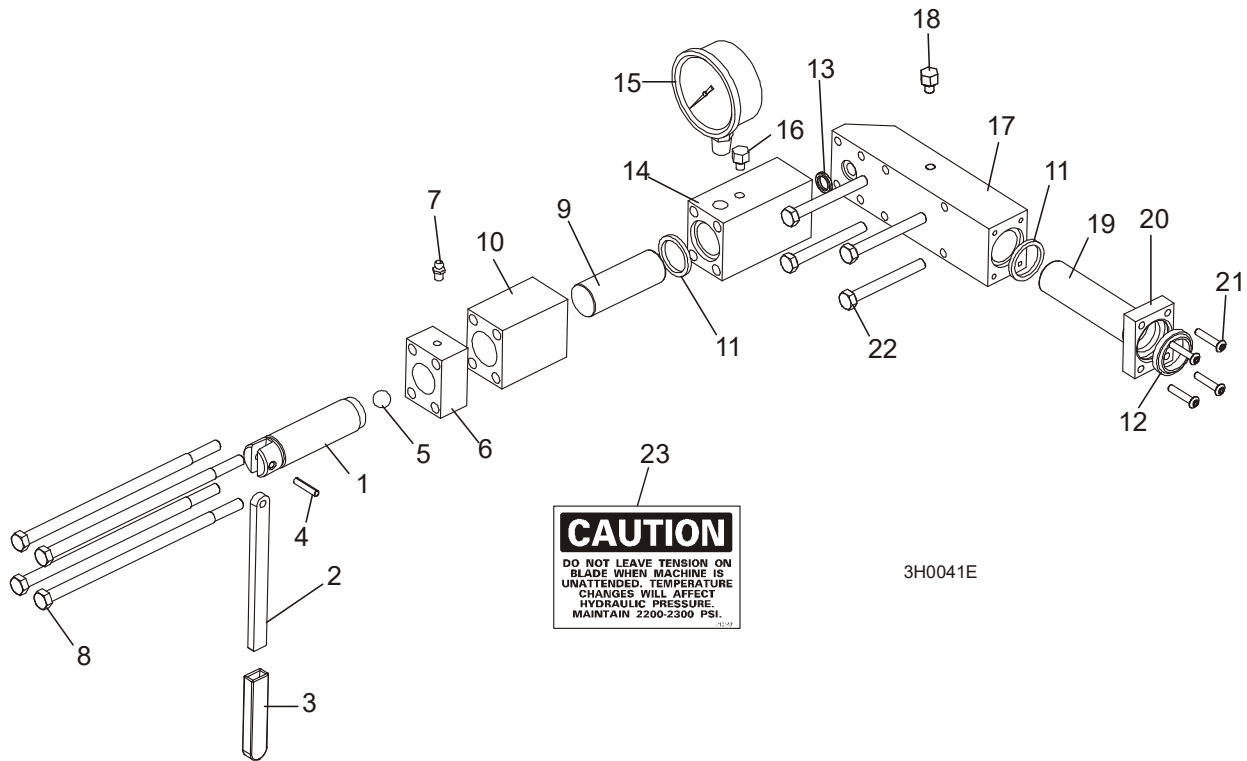

REF	PART #	DESCRIPTION	COMMENTS	QTY.
	A10136	HYDRAULIC BLADE TENSIONER ASSEMBLY		1
	A12294	Handle Assembly, Hydraulic Blade Tensioner Screw		1
1	S10056	Screw, Hydraulic Blade Tensioner	Available in assemblies only.	1
2	S08174	Handle, Hydraulic Tensioner Screw		1
3	P08072	Sleeve, Plastic Handle		1
4	F05012-19	Pin, 3/16" x 7/8" Roll		1
5	P02720	Ball, 1/2" Steel		1
6	S10062	Block, Threaded Tensioner End	Available in assemblies only.	1
7	P05060	Fitting, 1/4-28 Grease		1
	A12294-518	Instruction Sheet, Tensioner Screw		1
8	F05006-43	Bolt, 5/16-18 X 7 1/2" Hex Head Grade 5		4
9	S10060	Piston, Hydraulic Tensioner Front 2 3/4" Long		1
10	S10061	Block, Piston Guide		1
	003224	Seal Kit, Hydraulic Tensioner		1
5	P02720	Ball, 1/2" Steel		1
11	P10051	Seal, 1" Diameter		2
12	P10053	Wiper, 1" Diameter		1
13	P10377	Ring, 5/8" X 3/32" Square "O"		1
14	S10140	Block, Hydraulic Tensioner Gauge Mounting		1
15	P10052	Gauge, 3000 P.S.I. Hydraulic		1
16	P10065	Plug, Hydraulic Tensioner Fill		1
	016329	Block Assembly, Rear Tensioner Piston		1
17	S10142	Block, Rear Tensioner Piston	Available in assemblies only.	1
18	P10065	Plug, Hydraulic Tensioner Fill		1

REF	PART #	DESCRIPTION	COMMENTS	QTY.
19	S10059	Piston, Hydraulic Tensioner Rear 3 5/8" Long		1
20	S10089	Block, Rear Piston End		1
21	F05004-43	Bolt, #10-24 X 1" Socket Button Head		4
22	F05006-28	Bolt, 5/16-18 X 2 3/4" Hex Head Grade 5		4
23	P10147	Decal, Hydraulic Tension Caution		1
	A10136-272	Instruction Sheet, Hydraulic Tensioner Installation		1

SECTION 4 SAW HEAD FRAME

4.1 Middle Throat Screw

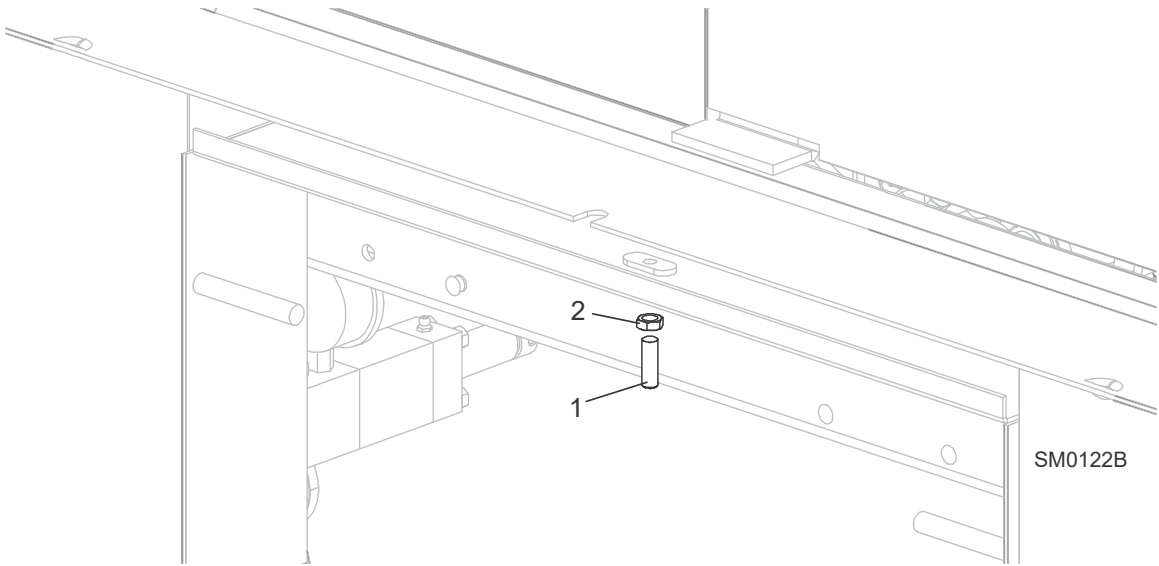

REF	PART #	DESCRIPTION	COMMENTS	QTY.
1	F05007-18	SCREW, 3/8-16 X 1 1/4" OVAL POINT SOCKET SET		1
2	F05010-29	NUT, 3/8-16 HEX JAM		1

4.2 Water Lube Solenoid Valve

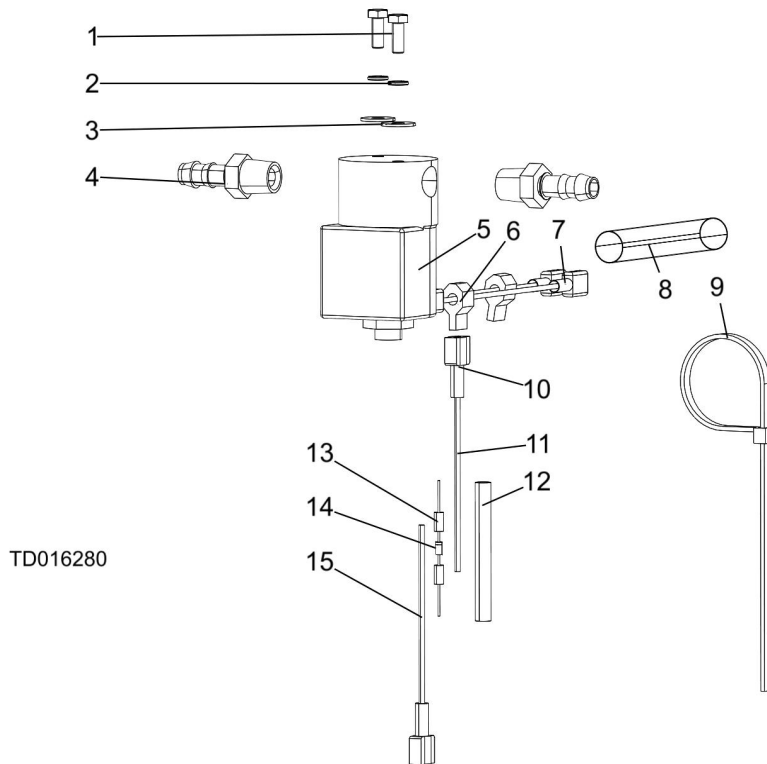

REF	PART #	DESCRIPTION	COMMENTS	QTY.
	016280	Solenoid Valve, Water Lube Kit		1
1	F05004-60	Bolt, #10-32x1/2 HH		2
2	F05011-20	Washer, #10 Split Lock		2
3	F05011-18	Washer, #10 SAE Flat		2
4	P04682	Fitting, 3/8 Barb 1/4NPT Male		2
	133071	Assy, Water Lube Solenoid Electrical		1
5	016140	Solenoid Valve, 2-Way NC 1/4 Port 12 VDC		1
6	F04875-13	Connector, TT-Tap 14-16Awg		2
7	F05708-21R	Terminal, 1/4 18-22Ga Quick Female FI		2
8	R02374	Conduit, 1/2" Flex Loom		1
9	F05089-3	Tie Wrap, 3/16x5 1/2 UV Blk		1
	024123	Diode Assy, Inductive Kick Protection		1
10	F05708-22R	Terminal, 1/4 18-22 Ga Qk Male FI Reel		2
11	R01915-3_3	Wire, 18AWG Stranded Red GXL		1
12	R01950-4_2_14	Tubing, 1/4" IDx2.25 Heat Shrink		1
13	024032	Conn, 14-16 AWG Parallel Splice		2
14	E05909	DIODE, 1N4003		1
15	R01915-0_3	Wire, 18AWG Stranded Black		1

4.3 Clutch Pivot

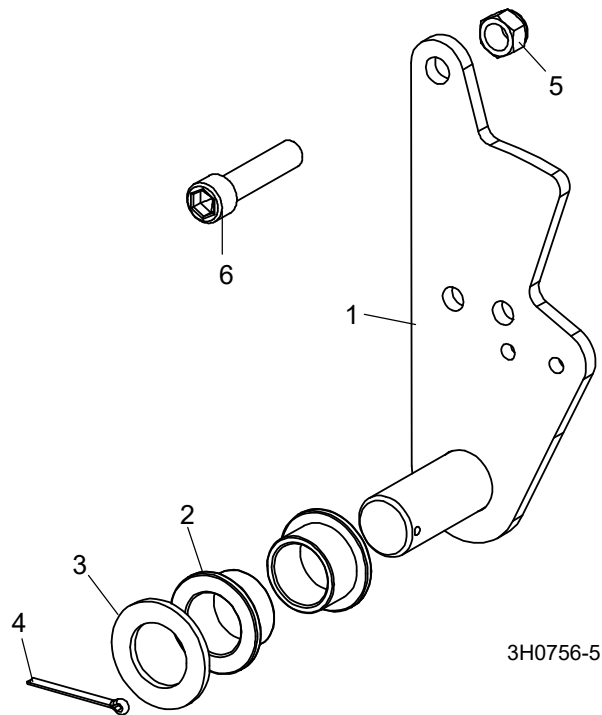

REF	PART #	DESCRIPTION	COMMENTS	QTY.
1	016296	Plate Weldment, Clutch Pivot		1
2	P737	Bushing, Clutch/Brake Pivot		2
3	P116	Washer, Clutch/Brake Pivot		1
4	F05012-49	Pin, 1/8" X 1 1/2" Cotter		1
5	F05010-83	Nut, 7/16-20 Hex Nylon Lock		1
6	F05007-120	Bolt, 7/16-20 x 2" SOcket Head		1

4.4 Clutch Mount Assembly

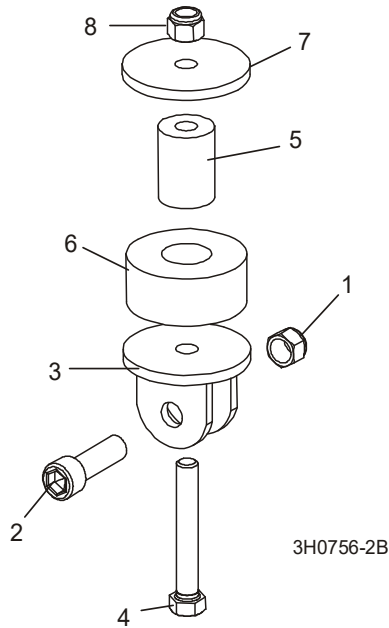

REF	PART #	DESCRIPTION	COMMENTS	QTY.
1	F05010-83	Nut, 7/16-20 Hex Nylon Lock		1
2	F05007-55	Bolt, 7/16-20 X 1 1/2" Socket Head		1
3	W12411	Bracket, Clutch Mount		1
4	F05007-157	Bolt, 3/8-16 x 2 1/2" Hex Head		1
5	016316	Spacer, Motor Mount Vibration Bushing		1
6	P05032	Bushing, Motor Mount Vibration		1
7	021276	Washer, .40" I.d. X 1.44" O.d. X .18" Thick		1
8	F05010-10	Nut, 3/8-16 Nylon Lock		1

4.5 Brake Assembly

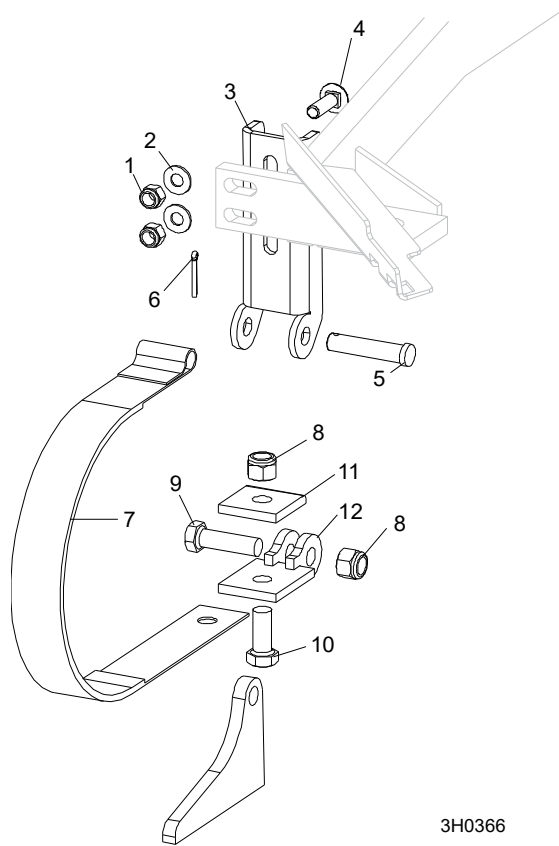

3H0366

REF	PART #	DESCRIPTION	COMMENTS	QTY.
	014441	Strap Retrofit, Super Brake	Service Kit	1
1	F05010-10	Nut, 3/8-16 Nylon Lock		2
2	F05011-3	Washer, 3/8" SAE Flat		2
3	014395	Bracket, Upper Super Brake Strap Mount		1
4	F05007-127	Bolt, 3/8-16 x 1 1/4" Carriage Head Grade 5		2
5	F05012-81	Pin, 1/2" x 2 1/4" Clevis		1
6	F05012-1	Pin, 1/8" x 1" Cotter		1
7	014391	Strap, Upper Pivot Metal Brake		1
8	F05010-8	Nut, 1/2-13 Nylon Lock		2
9	F05008-33	Bolt, 1/2-13x1 1/2 HH Gr5		1
10	F05008-37	Bolt, 1/2-13 x 1 1/4" Hex Head Grade 5		1
11	S04195	Plate, Brake Strap Clamp		1
12	014392	Bracket, Lower Super Brake Strap Mount		1

4.6 Brake Assembly (DC Only)

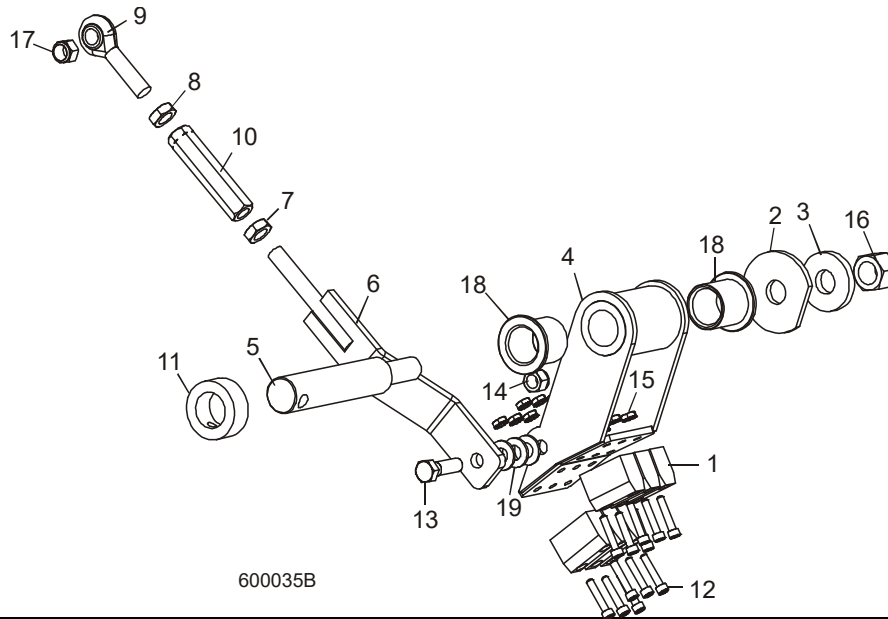

600035B

REF	PART #	DESCRIPTION	COMMENTS	QTY.
	034886	BRAKE ASSEMBLY, LT60/70		1
1	016488	Block, Blade Wheel Brake		6
2	017838	Washer, 21/32" x 2 1/4" x 3/16"		1
3	034685	Washer, 21/32" x 1 5/8" x 1/4"		1
4	034883	Arm Weldment, Pivot Brake		1
5	034885	Shaft, Pivot Brake		1
	034892	Linkage Assembly, Pivot Brake		1
6	034891	Arm Weldment, Pivot Brake Lik		1
7	F05010-38	Nut, 7/16-20 Jam		1
8	F05010-87	Nut, 7/16-20 Left Hand Jam		1
9	P11578	Rod End, 7/16-20 Left Hand Male		1
10	S11577	Turnbuckle, 3" Adjustment		1
11	038090	Collar, 1" Lock		1
12	F05004-2	Bolt, #10-24 x 1" Socket Head		12
13	F05007-123	Bolt, 3/8-16 x 1 1/4" Hex Head Grade 5		1
14	F05010-10	Nut, 3/8-16 Hex Nylon Lock		1
15	F05010-14	Nut, #10-24 Self-Locking Hex		12
16	F05010-71	Nut, 5/8-18 Hex Nylon Lock		1
17	F05010-83	Nut, 7/16-20 Hex Nylon Lock		1
18	P109	Bushing, 1" ID x 1 1/4" OD Flanged		2
19	F05011-3	Washer, 3/8" SAE Flat		3

4.7 Board Return Assembly

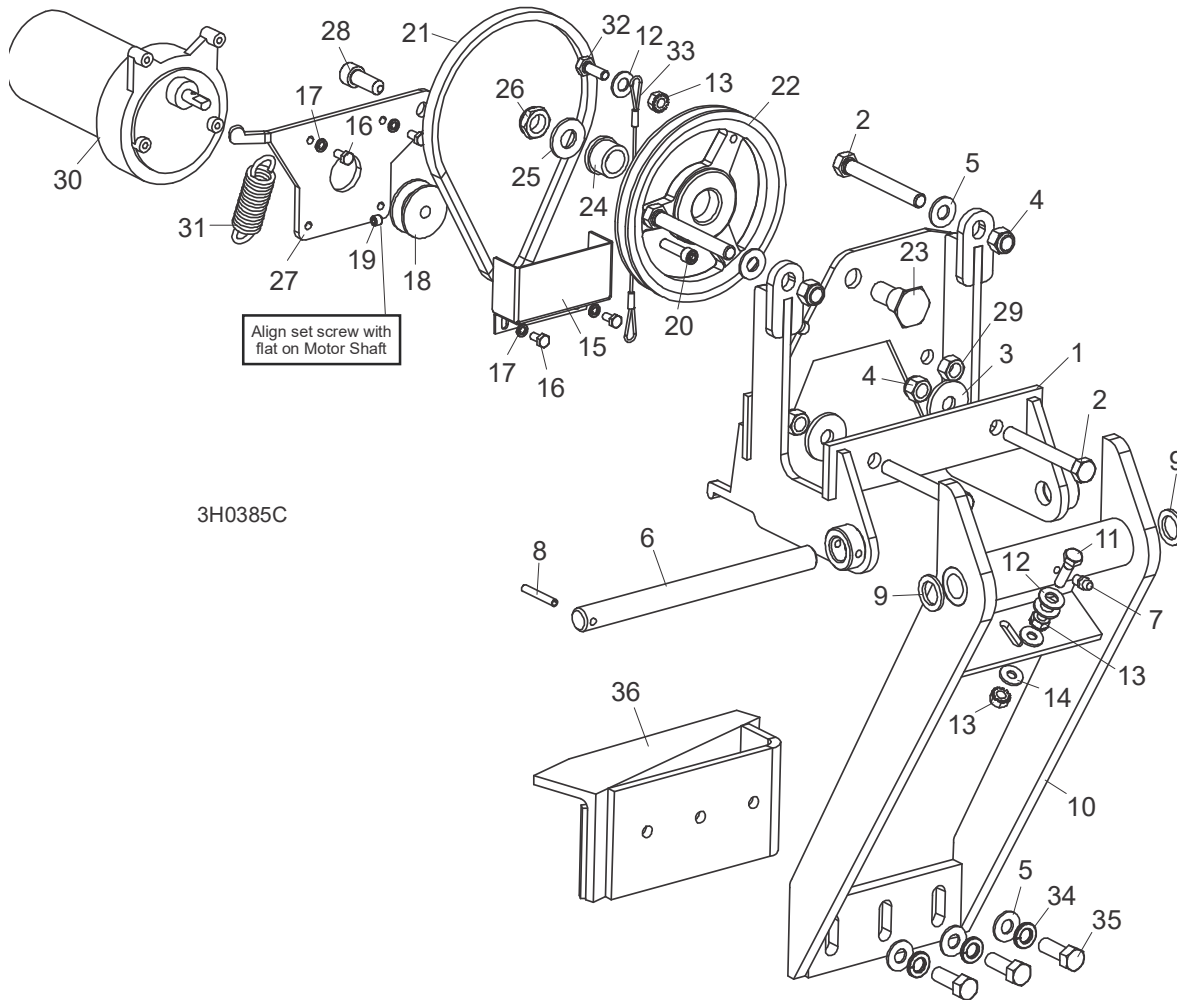

3H0385C

REF	PART #	DESCRIPTION	COMMENTS	QTY.
	015209	RETURN ASSEMBLY, BOARD		1
1	015215	Mount Weldment, Board Return		1
2	F05007-1	Bolt, 3/8-16 x 3" Full Thread Hex Head		4
3	015336	Washer, 1/8" x 1 1/4"		2
4	F05010-10	Nut, 3/8-16 Hex Nylon Lock		4
5	F05011-3	Washer, 3/8" Flat		5
6	016272	Rod Kit, Board Return Replacement Pivot		1
7	P05060	Fitting, 1/4-28 Grease		1
8	F05012-16	Pin, 3/16 x 1 1/4" Roll		1
9	F05011-19	Washer, 5/8" x 15/16" x .094 Nylon		2
10	015210	Arm Weldment, Board Return		1
11	F05005-1	Screw, 1/4-20 x 3/4" Full Thread Hex Head		1
12	F05011-17	Washer, 5/16" SAE Flat		3
13	F05010-9	Nut, 1/4-20 Self-Locking		3
14	F05011-11	Washer, 1/4" SAE Flat		2
15	015007	Guard, Board Return Belt		1
16	F05004-60	Screw, #10-32 x 1/2" Hex Head Machine		4
17	F05011-20	Washer, #10 Split Lock		4
18	015074	Pulley, 1.42" x .32"		1

REF	PART #	DESCRIPTION	COMMENTS	QTY.
19	F05005-105	Screw, 1/4-28 x 1/4" Socket Head Cup Point Set		1
20	F05005-89	Bolt, 1/4-20 x 1" Socket Head		1
21	015477	Belt, 3L190		1
22	015224	Pulley, OK50 x 1/2" Modified		1
23	015221	Bolt, Idler Pulley Pivot		1
24	P05135	Bushing, 5/8" x 7/8" x 1/2" Bronze		1
25	F05011-2	Washer, 1/2" SAE Flat		1
26	F05010-79	Nut, 1/2-20 Nylon Lock Jam		1
27	015220	Plate, Motor Pivot		1
28	F05007-52	Bolt, 3/8-16 x 1" Socket Head		1
29	F05010-25	Nut, 3/8-16 Self-Locking		1
30	079214	Motor, Current Applications 1/30HP 12VDC Gear		1
	061232	Gear Kit, Motor Replacement		1
	061234	Brush Kit, Gear Motor Replacement		1
	061233	Shaft Kit, Gear Motor Replacement		1
31	015479	Spring, 3/4" x 2 7/8" x 12 Gauge		1
32	F05005-101	Bolt, 1/4-20 x 1" Hex Head Grade 5		1
33	016090	Cable, Board Return		1
34	F05011-4	Washer, 3/8" Split		3
35	F05007-7	Bolt, 3/8-16 x 1" Hex Head		3
36	015652	Angle, Board Return		1

4.8 Water Lube Assembly (Gas Only)

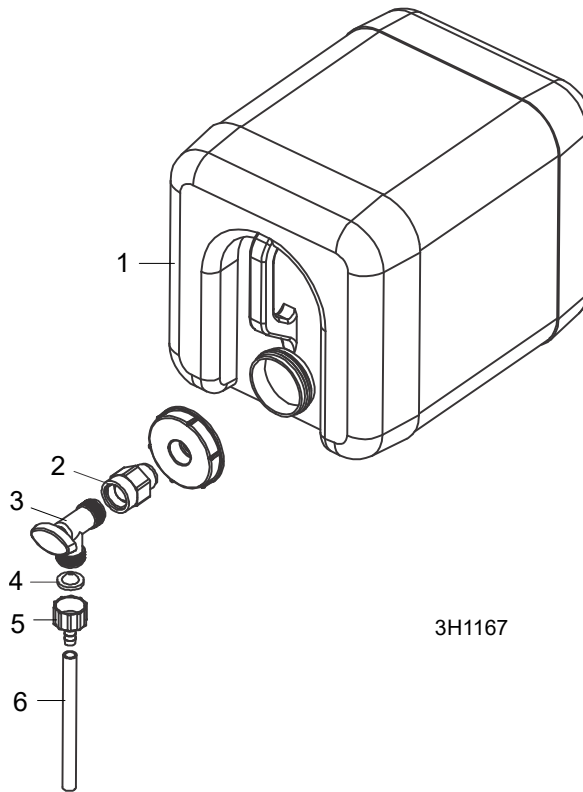

REF	PART #	DESCRIPTION	COMMENTS	QTY.
1	014642	BOTTLE ASSEMBLY, WATER LUBE W/CAP		1
	061372	O-ring, Water Bottle Cap	If the water bottle cap keeps leaking, add this o-ring to the cap. Leave the existing o-ring installed.	1
2	014636	FITTING, 3/4FPT X 3/4MPT		1
3	014100	FITTING, WATER LUBE SHUTOFF VALVE		1
4	016086	FILTER, WATER LUBE	Filter recommended for LT50-Super models to prevent debris from entering water lube solenoid valve.	1
5	014113	FITTING, 5/8" NPT TO 3/8" HOSE BARB		1
6	R01885	TUBING, WATER LUBE 3/8" I.D.		7 ft.
	CBOTTLE	COVER, 5 GAL. WATER BOTTLE OPTIONAL (NOT SHOWN)		1

4.9 Water Lube Assembly (Diesel & Electric Only)

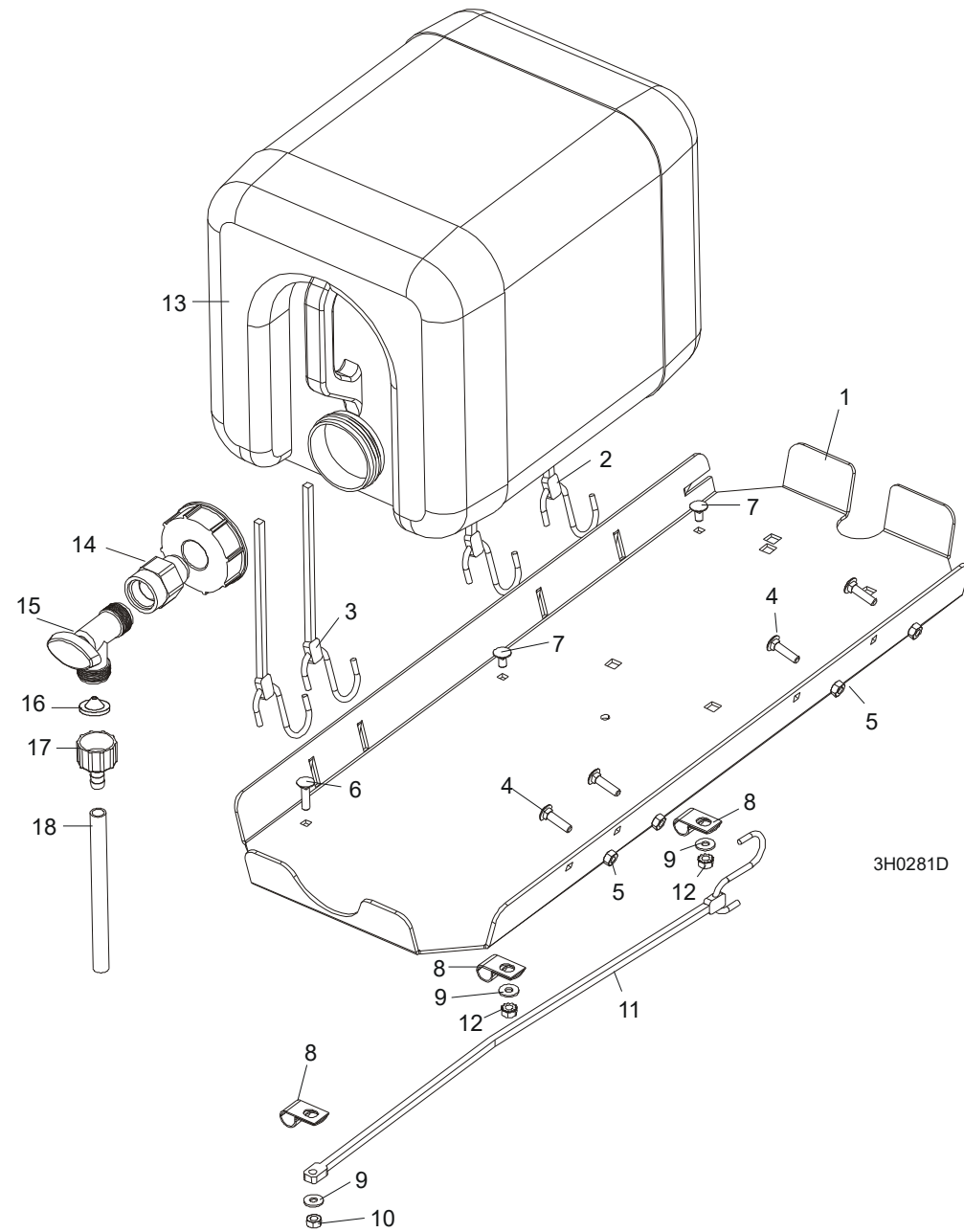

REF	PART #	DESCRIPTION	COMMENTS	QTY.
	A11685	TRAY ASSEMBLY, FUEL TANK/WATER BOTTLE		1
1	S11684	Tray, Fuel Tank/Water Bottle		1
2	P11258	Strap, 24" Rubber (For Fuel Tank - See Engine Manual)		2
3	P11668	Strap, 20" Rubber		2
4	F05005-34	Bolt, 1/4-20 X 1" Carriage Head		4
5	F05010-21	Nut, 1/4-20 Hex Lock		4
6	F05005-34	BOLT, 1/4-20 X 1" CARRIAGE HEAD		1
7	F05005-33	BOLT, 1/4-20 X 1/2" CARRIAGE HEAD		2
8	P07584	CLAMP, 1/2" EMT HOSE		3
9	F05011-11	WASHER, 1/4" SAE FLAT		3

REF	PART #	DESCRIPTION	COMMENTS	QTY.
10	F05010-21	NUT, 1/4-20 HEX LOCK		1
11	P07461	STRAP, 15" RUBBER		1
12	F05010-9	NUT, 1/4-20 SELF-LOCKING		2
13	014642	BOTTLE ASSEMBLY, WATER LUBE W/CAP		1
	061372	O-ring, Water Bottle Cap	If the water bottle cap keeps leaking, add this o-ring to the cap. Leave the existing o-ring installed.	1
14	014636	FITTING, 3/4FPT X 3/4MPT		1
15	014100	FITTING, WATER LUBE SHUTOFF VALVE		1
16	016086	FILTER, WATER LUBE		1
17	014113	FITTING, 5/8" NPT TO 3/8" HOSE BARB		1
18	R01885	TUBING, WATER LUBE 3/8" I.D.		7 ft.

4.10 Saw Head Decals

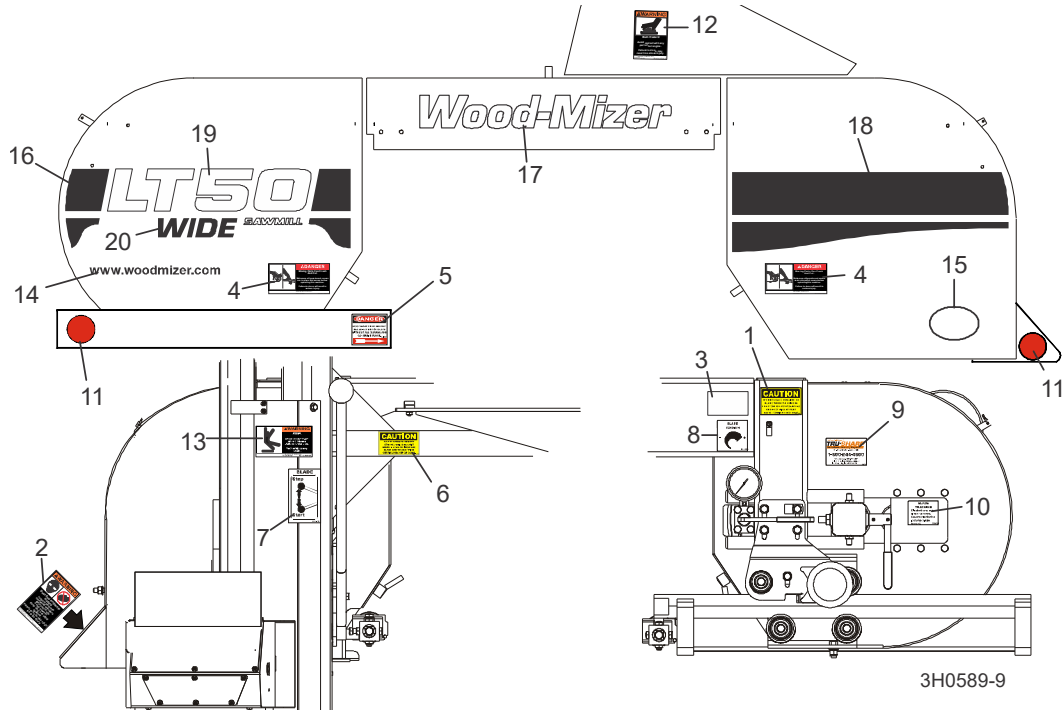

REF	PART #	DESCRIPTION	COMMENTS	QTY.
1	P10147	DECAL, BLADE TENSION CAUTION		1
2	P11754	DECAL, SAWDUST CHUTE WARNING		1
3	P12373	DECAL, BLADE TENSION RANGES		1
4	033254	DECAL, BLADE COVERS DANGER		2
5	S11752	DECAL, BLADE DANGER ARROW RIGHT		1
6	S11762	DECAL, UP/DOWN CAUTION		1
7	P11779	DECAL, BLADE START/STOP		1
8	P11790	DECAL, BLADE TENSION INFO		1
9	P12879	DECAL, TRU-SHARP INFO		1
10	P11789	DECAL, BLADE ALIGNMENT INFO		1
11	P07452	DECAL, RED REFLECTIVE 2" ROUND		2
12	014419	DECAL, HOT ENGINE WARNING		1
13	016072	DECAL, BOARD RETURN OPERATOR WARNING		1
14	003235	DECAL, WOOD-MIZER WEBSITE		1
15	065582	DECAL, 30 YEAR LOGO		1
16	065027	DECAL, LT50 IDLE SIDE BLACK EURO STRIPE		1
17	065025	DECAL, LT40/50 WHITE WOOD-MIZER LOGO		1
18	065026	DECAL, LT40/50 DRIVE SIDE BLACK EURO STRIPE		1
19	065028	DECAL, LT50 WHITE EURO LOGO		1
20	074335	DECAL, LT15/70 WIDE LOGO (WIDE HEAD ONLY)		1

4.11 Blade Housing Covers

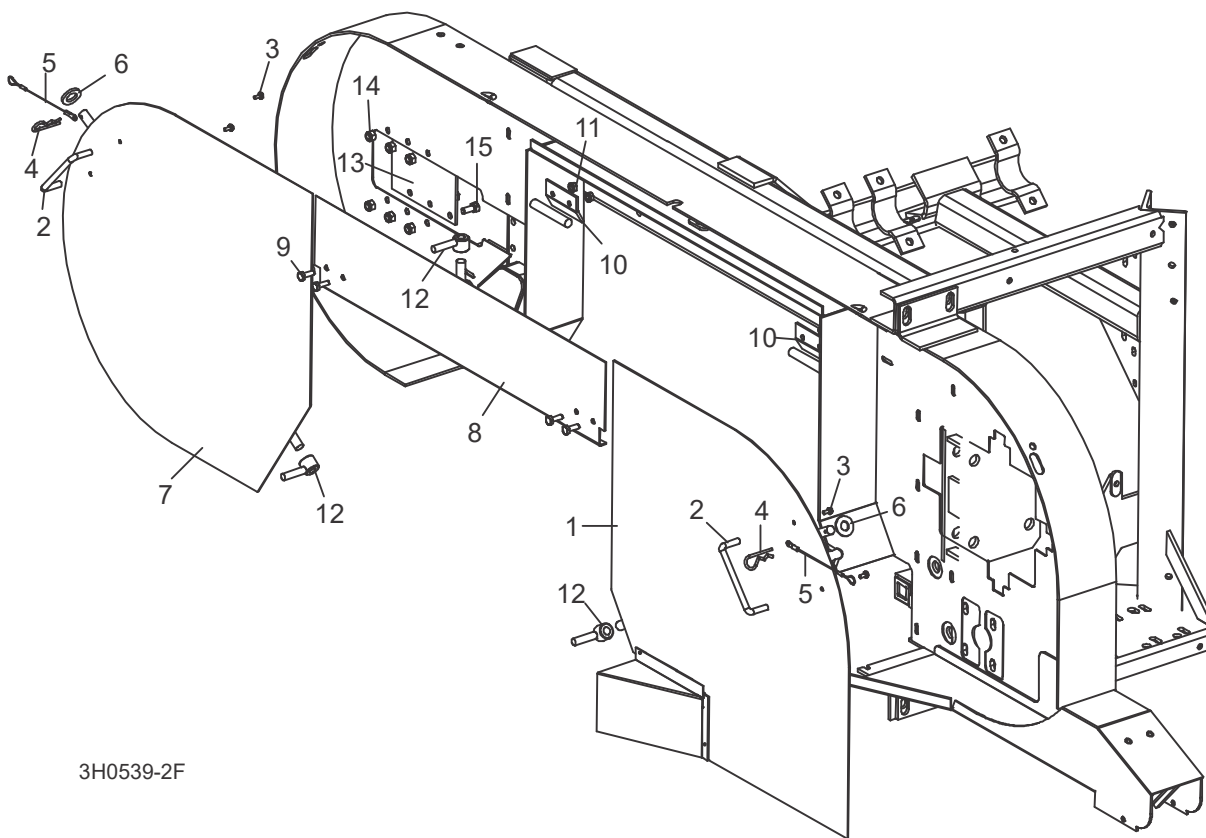

3H0539-2F

REF	PART #	DESCRIPTION	COMMENTS	QTY.
	015937	COVER ASSEMBLY, DRIVE SIDE BLADE HOUSING WITH HANDLE		1
1	015911	Cover, Drive Side Blade Housing	Available in assemblies only. (Includes Cover Decal - (See Section 4.10))	1
2	P08065	Handle, Blade Housing Cover		1
3	F05015-8	Screw, #8-32 X 3/8" Self-Tap		2
	A12812	Pin Assembly, Cover Retainer		1
4	P05059	Pin, Safety Retainer		1
5	016030	Cable, 3/64" x 6" Lanyard		1
6	F05011-87	Washer, 1/2" ID x 1 1/8" OD x .093" Rubber		1
	A09419	COVER, IDLE SIDE BLADE HOUSING WITH HANDLE		1
7	W09351	Cover, Idle Side Blade Housing	Available in assemblies only. (Includes Cover Decal - (See Section 4.10))	1
2	P08065	Handle, Blade Housing Cover		1
3	F05015-8	Screw, #8-32 X 3/8" Self-Tap		2
	A12812	Pin Assembly, Cover Retainer		1
4	P05059	Pin, Safety Retainer		1
5	016030	Cable, 3/64" x 6" Lanyard		1
6	F05011-87	Washer, 1/2" ID x 1 1/8" OD x .093" Rubber		1
8	W07409	COVER, MIDDLE BLADE HOUSING		1
	079509	COVER, MIDDLE BLADE HOUSING (WIDE HEAD ONLY)		1

REF	PART #	DESCRIPTION	COMMENTS	QTY.
9	F05005-1	BOLT, 1/4-20 X 3/4" HEX HEAD		18
10	S07522	HINGE, MIDDLE BLADE HOUSING COVER		2
11	F05010-9	NUT, 1/4-20 SELF-LOCKING HEX		4
12	021145	NUT, COVER TURN		3
13	S04433	PLATE, IDLE BLADE WHEEL GUARD		1
14	F05010-58	NUT, 5/16-18 HEX NYLON LOCK		6
15	F05006-5	BOLT, 5/16-18 X 3/4" HEX HEAD GRADE 2		6

4.12 Drive Belt Covers

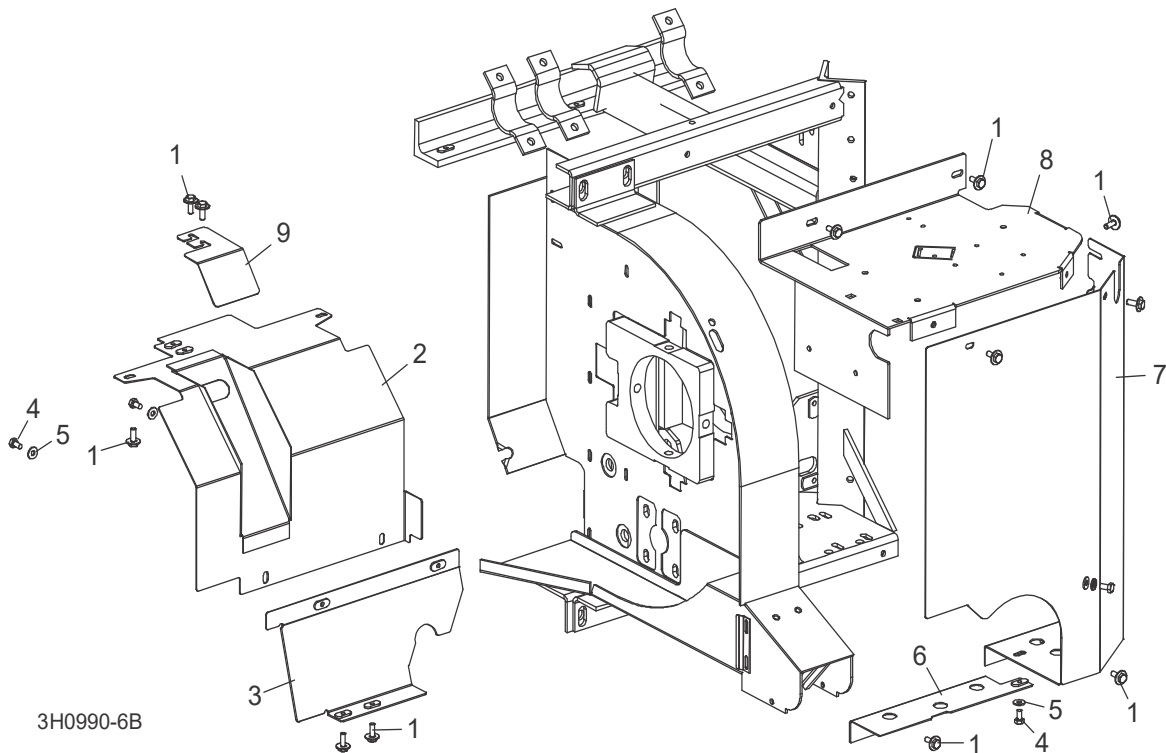

REF	PART #	DESCRIPTION	COMMENTS	QTY.
1	F05005-134	BOLT, 1/4-20 X 3/4" HEX HEAD WITH CONICAL WASHER		15
2	006026	GUARD WELDMENT, SUPER/REMOTE LOWER DRIVE BELT	For sawmills equipped with standard manual clutch handle only. See Autoclutch Option manual for alternate guards.	1
3	006025	MOUNT WELDMENT, LOWER DRIVE BELT		1
4	F05005-15	BOLT, 1/4-20 X 1/2" HEX HEAD		3
5	F05011-11	WASHER, 1/4" SAE FLAT		3
6	015654	GUARD WELDMENT, LOWER UP/DOWN		1
7	008776	GUARD, SUPER DRIVE PULLEY SIDE		1
8	059599	GUARD, DRIVE PULLEY TOP		1
9	074752	PLATE, LT40 BELT GUARD COVER		1

4.13 Sawdust Chute

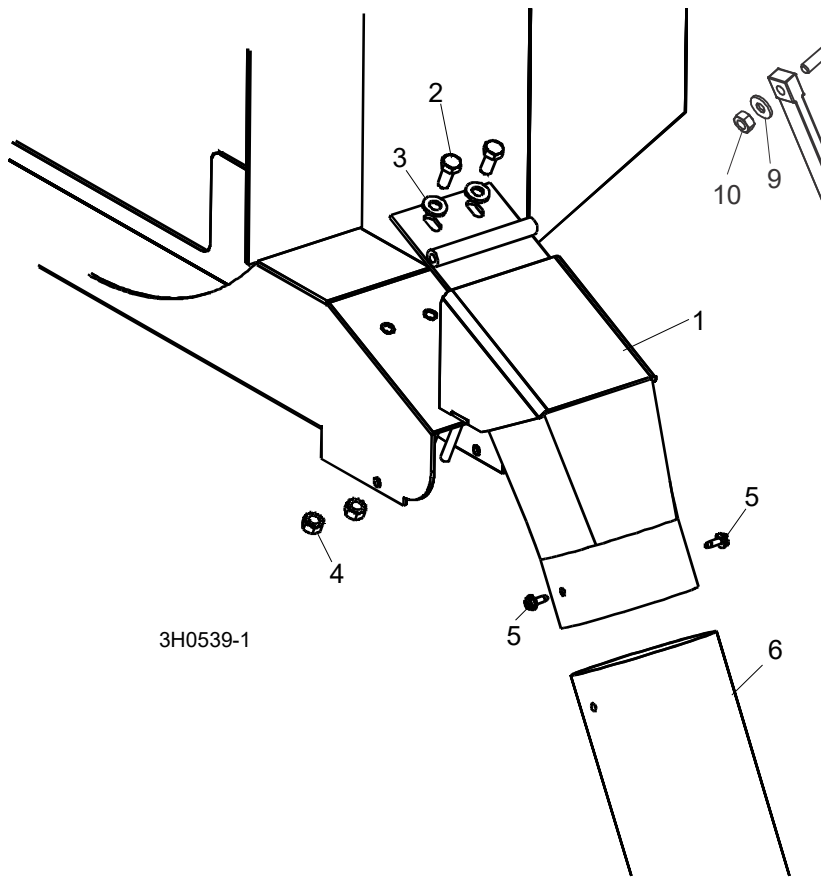

REF	PART #	DESCRIPTION	COMMENTS	QTY.
1	015466	CHUTE WELDMENT, SAWDUST		1
2	F05006-5	BOLT, 5/16-18 X 3/4" HEX HEAD GRADE 2		2
3	F05011-17	WASHER, 5/16" SAE FLAT		2
4	F05010-20	NUT, 5/16-18 SELF-LOCKING HEX		2
5	F05015-7	BOLT, #10-24 X 1/2" SELF-TAPPING		2
6	016727	TUBING, RUBBER SAWDUST		1
	P11668	STRAP, 20" RUBBER W/HOOK		1
	F05005-3	BOLT, 1/4-20 X 1 1/4" HEX HEAD FULL THREAD		1
	F05011-11	WASHER, 1/4" SAE FLAT		1
	F05010-21	NUT, 1/4-20 LOCK		1

4.14 Debarker Wire Box/Hole Plugs

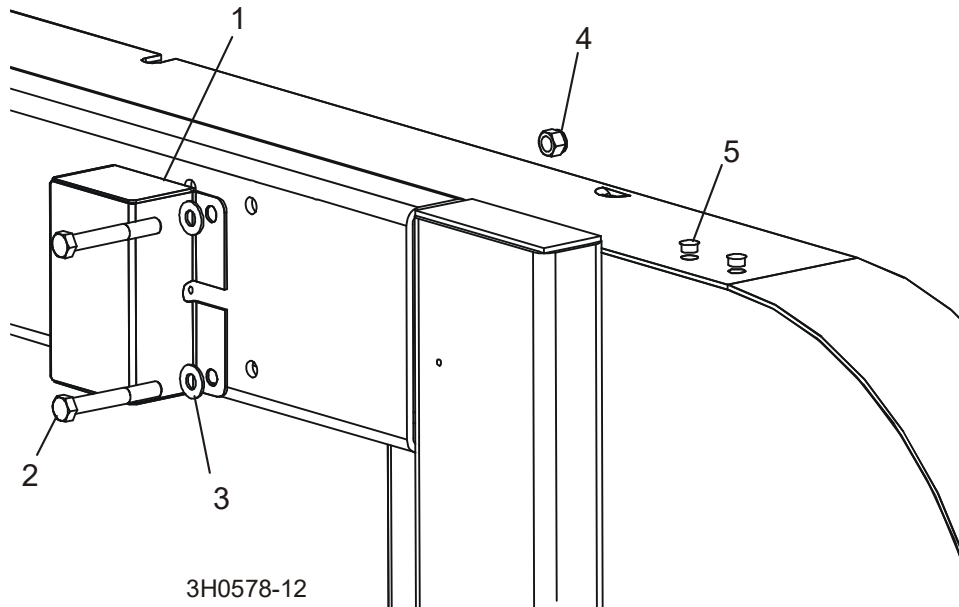

REF	PART #	DESCRIPTION	COMMENTS	QTY.
1	023616	BOX, DEBARKER WIRE STORAGE		1
2	F05007-29	BOLT, 3/8-16 X 2 3/4" HEX HEAD		2
3	F05011-3	WASHER, 3/8" SAE FLAT		2
4	F05010-10	NUT, 3/8-16 HEX NYLON LOCK		2
5	014537	PLUG, 13/32" PLASTIC HOLE		2

SECTION 5 CONTROL & BATTERY BOXES

5.1 Control Assembly

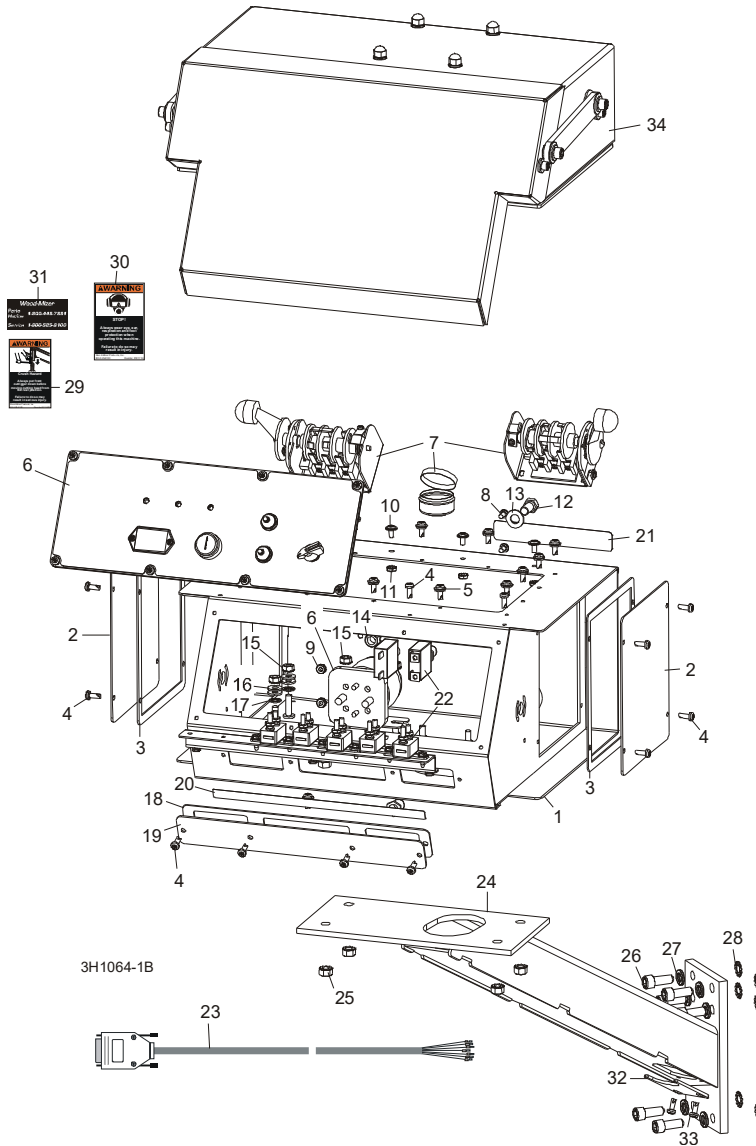

REF	PART #	DESCRIPTION	COMMENTS	QTY.
	015764	COVER, SAWMILL CONTROL CONSOLE		1
	036352	COVER, SAWMILL CONTROL CONSOLE W/ACCUSET		1
	069426	CONTROL BOX ASSEMBLY, E25 DUAL-AXIS		1
	069421	CONTROL BOX ASSEMBLY, G38 DUAL-AXIS		1
	069422	CONTROL BOX ASSEMBLY, D35 DUAL-AXIS (TIER2 ONLY)	Replaced with D35 Tier4 Control Box Assembly for the U.S. only (LT40HD Super Rev. K4.00+/LT50 Rev. A6.00+). See Section Control Assembly (D35 Tier4 Only).	1
	069422	CONTROL BOX ASSEMBLY, D47 DUAL-AXIS		1
	069420	CONTROL BOX ASSEMBLY, D51 DUAL-AXIS		1
1	025823	Box Weldment, Sawmill Control	Available in assemblies only.	1

5 Control & Battery Boxes

Control Assembly

REF	PART #	DESCRIPTION	COMMENTS	QTY.
2	006473	Panel, Control Box Side		2
3	015274	Gasket, Side Panel Control		2
4	F05015-17	Screw, #10-24 x 1/2" Pan Head		16
5	F05004-186	Screw, #10-24 x 1/2" Phillips Head		14
6	N/A	Front Control Panel & Wiring Harnesses (See Section 5.5)		1
7	N/A	Drum Switches (See Section 5.3)		1
8	F05004-3	Screw, #10-24 x 3/8" Phillips Pan Head		2
9	F05010-14	Nut, #10-24 Self Locking		2
10	F05004-148	Screw, #10-24 x 3/8" Phillips Pan Head Machine with Neo Washer		4
11	F05010-14	Nut, #10-24 Self-Locking Hex		4
12	F05007-27	Bolt, 3/8-16 x 3/4" Hex Head		1
13	F05011-3	Washer, 3/8" SAE Flat		1
14	F05010-19	Nut, 3/8" Lock Nut		1
15	F05010-9	Nut, 1/4-20 Self Locking		4
16	F05011-11	Washer, 1/4" SAE Flat		4
17	F05011-69	Washer, 1/4" Interior Star Heavy Duty Lock		2
18	015266	Gasket, Front Access Panel		1
19	015376	Panel, Control Box Front Access		1
20	069412	Decal, Front Circuit Breaker ID (Super NR Dual-Axis)		1
21	069414	Decal, Rear Circuit Breaker ID (Super NR Dual-Axis)		1
22	N/A	Circuit Breakers (See Section 5.4)		1
23	053355	Harness Assembly, Dual-Axis Motor Control Non-Remote		1
24	015236	MOUNT WELDMENT, STANDARD CONTROL BOX		1
25	F05010-20	NUT, 5/16-18 SELF-LOCKING HEX		4
26	F05007-52	BOLT, 3/8-16 X 1" SOCKET HEAD		6
27	F05011-4	WASHER, 3/8" SPLIT LOCK		6
28	F05011-36	WASHER, 3/8" EXTERIOR STAR LOCK		6
29	015400	DECAL, FRONT OUTRIGGER WARNING		1
30	S11753	DECAL, EAR/EYE PROTECTION WARNING		1
31	S12117	DECAL, 800 NUMBER		1
32	036381	PLATE, PEDESTAL COVER		1
33	F05015-17	SCREW, #10-24 X 1/2" PAN HEAD		2
34	N/A	ACCUSET PARTS (See AccuSet 2 Manual)		1

5.2 Control Assembly (Tier4 Only)

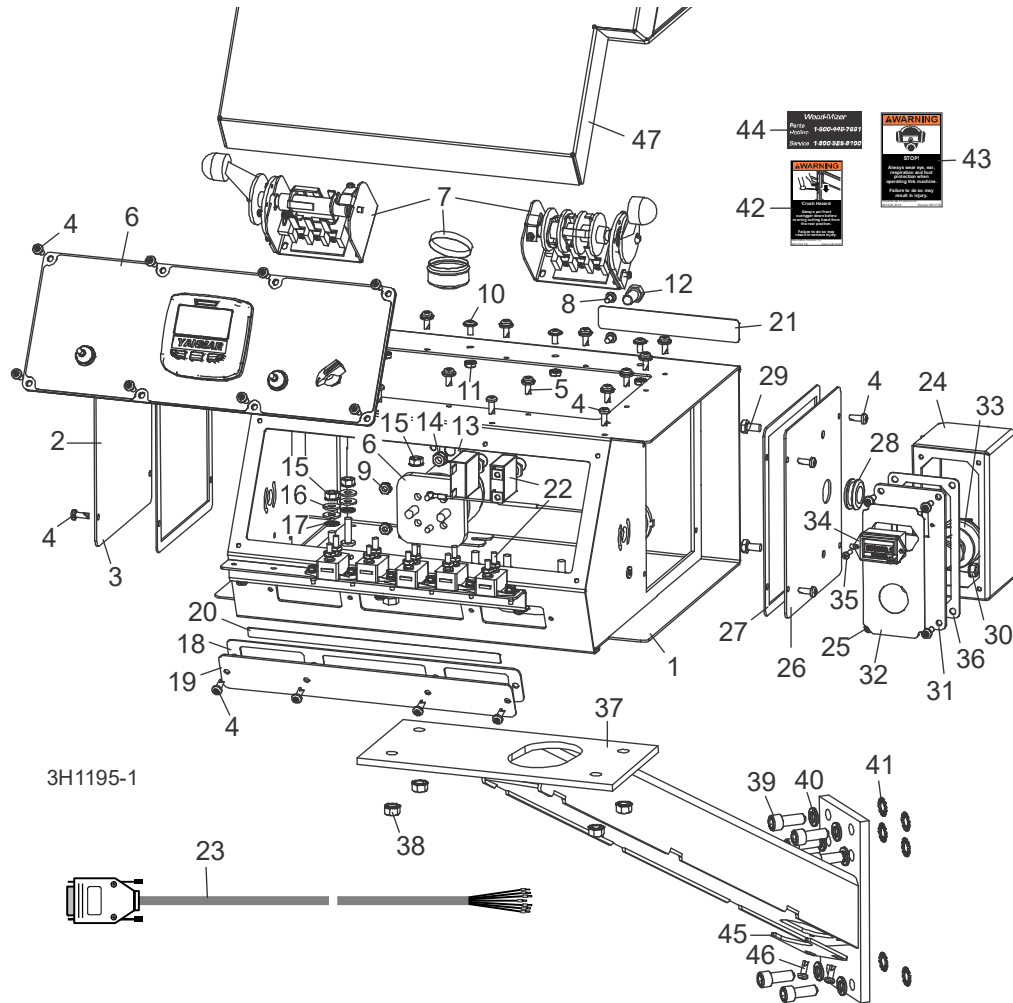

REF	PART #	DESCRIPTION	COMMENTS	QTY.
	015764	COVER, SAWMILL CONTROL CONSOLE		1
	036352	COVER, SAWMILL CONTROL CONSOLE W/ACCUSET		1
	073590	CONTROL BOX ASSEMBLY, D35 TIER4 DUAL-AXIS		1
1	025823	Box Weldment, Sawmill Control	Available in assemblies only.	1
2	006473	Panel, Control Box Side		2
3	015274	Gasket, Side Panel Control		2
4	F05015-17	Screw, #10-24 x 1/2" Pan Head		16
5	F05004-186	Screw, #10-24 x 1/2" Phillips Head		14
6	N/A	Front Control Panel & Wiring Harnesses (See Section 5.5)		1
7	N/A	Drum Switches (See Section 5.3)		1
8	F05004-3	Screw, #10-24 x 3/8" Phillips Pan Head		2
9	F05010-14	Nut, #10-24 Self Locking		2
10	F05004-148	Screw, #10-24 x 3/8" Phillips Pan Head Machine with Neo Washer		4
11	F05010-14	Nut, #10-24 Self-Locking Hex		4
12	F05007-27	Bolt, 3/8-16 x 3/4" Hex Head		1
13	F05011-3	Washer, 3/8" SAE Flat		1
14	F05010-19	Nut, 3/8" Lock Nut		1

5 Control & Battery Boxes

Control Assembly (Tier4 Only)

REF	PART #	DESCRIPTION	COMMENTS	QTY.
15	F05010-9	Nut, 1/4-20 Self Locking		4
16	F05011-11	Washer, 1/4" SAE Flat		4
17	F05011-69	Washer, 1/4" Interior Star Heavy Duty Lock		2
18	015266	Gasket, Front Access Panel		1
19	015376	Panel, Control Box Front Access		1
20	069412	Decal, Front Circuit Breaker ID (Super NR Dual-Axis)		1
21	069414	Decal, Rear Circuit Breaker ID (Super NR Dual-Axis)		1
22	N/A	Circuit Breakers (See Section 5.4)		1
23	053355	Harness Assembly, Dual-Axis Motor Control Non-Remote		1
	073603	Box Assembly, Key Switch		1
24	078426	Control Box Weldment, Key/Hour		1
25	F05015-17	Bolt, #10-24x1/2 Ph Pan Hd, Type 23		4
26	033495	Panel Weldment, Side L.H.		1
27	015274	Gasket, Side Panel Control 97		1
28	033475	Grommet, 5/8 ID 3/16 GW Rubber		1
29	F05005-15	Bolt, 1/4-20x1/2 HH		2
30	F05010-9	Nut, 1/4-20 Keps		2
	073597	Panel Assembly, Key Switch Box Frt		1
31	073598	Plate, Key Switch Box Front		1
32	073594	Decal, Key Switch		1
33	P04350	Switch, Key		1
34	015401	Digital Meter, Hour Rect Mount w/ Gasket		1
35	F05015-28	Screw, #6-32x1/2 Plain PH T23		2
36	033488	Gasket, LMS Panel		1
37	015236	MOUNT WELDMENT, STANDARD CONTROL BOX		1
38	F05010-20	NUT, 5/16-18 SELF-LOCKING HEX		4
39	F05007-52	BOLT, 3/8-16 X 1" SOCKET HEAD		6
40	F05011-4	WASHER, 3/8" SPLIT LOCK		6
41	F05011-36	WASHER, 3/8" EXTERIOR STAR LOCK		6
42	015400	DECAL, FRONT OUTRIGGER WARNING		1
43	S11753	DECAL, EAR/EYE PROTECTION WARNING		1
44	S12117	DECAL, 800 NUMBER		1
45	036381	PLATE, PEDESTAL COVER		1
46	F05015-17	SCREW, #10-24 X 1/2" PAN HEAD		2
47	N/A	ACCUSET PARTS (See AccuSet 2 Manual)		1

5.3 Drum Switches

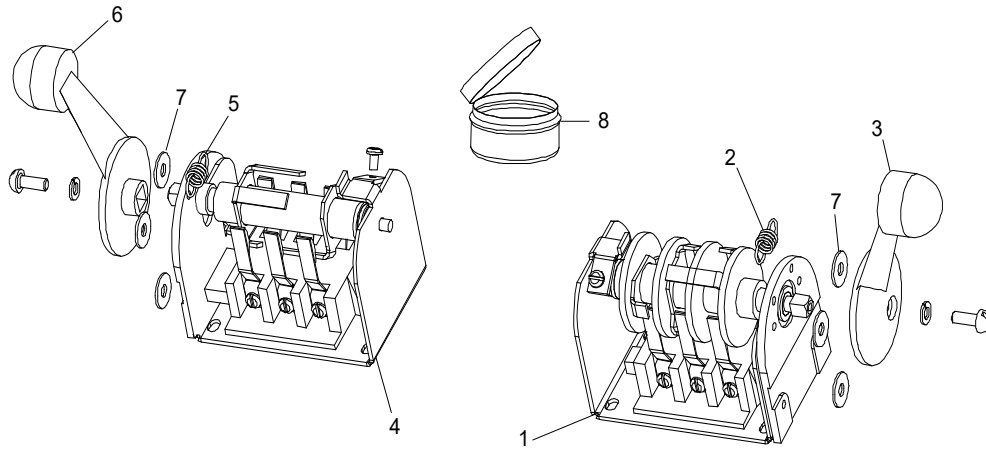

3H0421

REF	PART #	DESCRIPTION	COMMENTS	QTY.
	E20440	SWITCH ASSEMBLY, UP/DOWN DRUM		1
1	E20440-B	Switch, S12 Bulk Drum	Available in assemblies only.	1
2	P12570	Spring, Drum Switch		1
3	P12500	Handle, Drum Switch Replacement		1
	E20439	SWITCH ASSEMBLY, POWER FEED DRUM		1
4	E20439-B	Switch, S11 Bulk Drum	Available in assemblies only.	1
5	P12570	Spring, Drum Switch		1
6	P12500	Handle, Drum Switch Replacement		1
7	F05011-41	WASHER, #8 SAE FLAT		6
8	A20463	CUP ASSEMBLY, DRUM SWITCH GREASE		1

5.4 Circuit Breakers

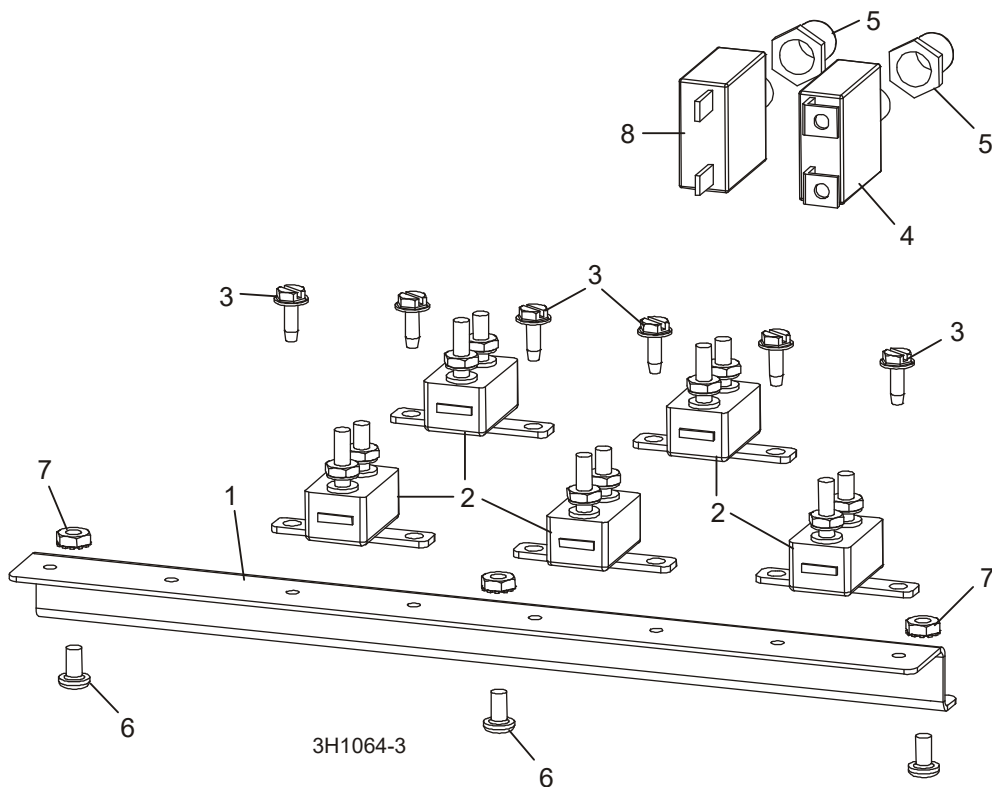

REF	PART #	DESCRIPTION	COMMENTS	QTY.
	015621	BREAKER ASSEMBLY, SAWMILL CONTROL CIRCUIT		1
1	052826	Rail, Circuit Breaker		1
2	E20430	Breaker, 15 Amp Manual Reset		5
3	F05015-7	Screw, #10-24 x 1/2" Self-Tapping		6
4	015527	BREAKER, 70 AMP MANUAL RESET PANEL MOUNT		1
5	021253	BOOT, CIRCUIT BREAKER		2
6	F05004-3	SCREW, #10-24 X 3/8" PHILLIPS PAN HEAD		3
7	F05010-14	NUT, #10-24 SELF LOCKING		3
8	024246	BREAKER, 30A MANUAL RESET PANEL MOUNT		1

5.5 Front Panel Assembly & Harnesses

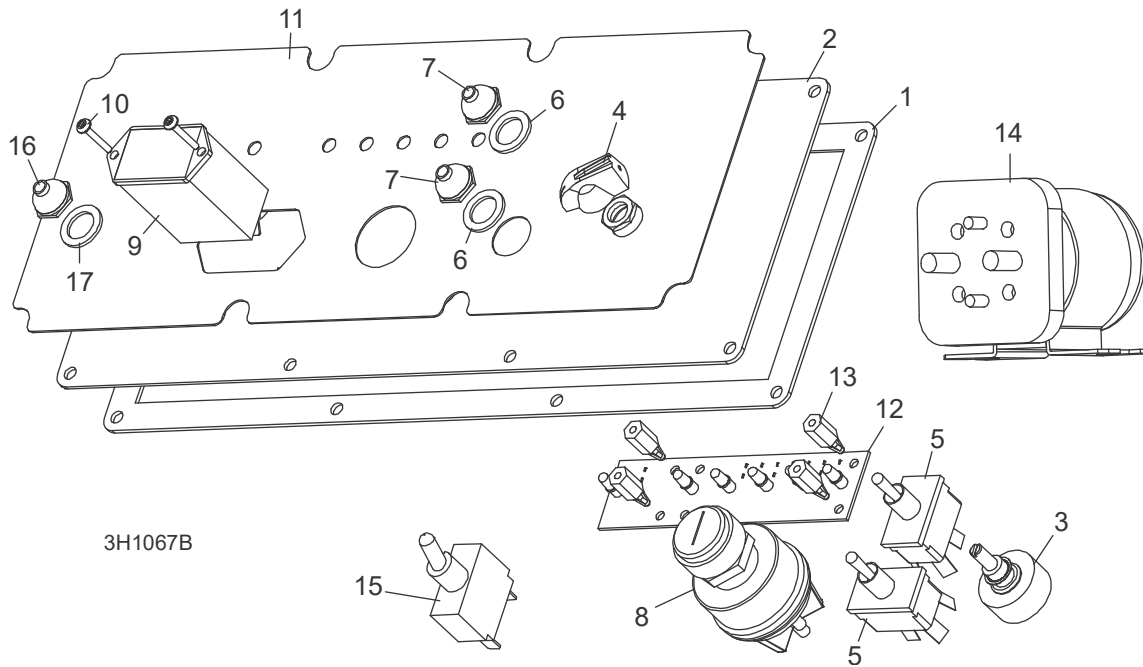

REF	PART #	DESCRIPTION	COMMENTS	QTY.
	069417	PANEL ASSEMBLY, CONTROL FRONT E25		1
	069416	PANEL ASSEMBLY, CONTROL FRONT (G38/D47/D51)		1
1	015270	Gasket, Front Panel		1
2	015302	Panel Weldment, Control		1
3	024450-1	Switch Assembly, Feed Rate		1
4	P06257	Knob, Feed Rate With Set Screw		1
5	024200	Switch, Toggle		2
6	P02575	Boot, Toggle Switch Rubber		2
7	P05251-1	Washer, 1/2 x 3/4 x 1/16 Nylon		2
8	P04350	Switch, Key		1
9	015401	Meter, Hour		1
10	F05015-28	Screw, #6-32 x 1/2" Plain PH T23		2
11	015271	Decal, Control Panel (E25/E30)		1
	015269	Decal, Control Panel (Gas/Diesel)		1
12	015416	Board, LED Circuit (E25/E30)		1
	015409	Board, LED Circuit (Gas/Diesel)		1
13	023147	Spacer, 1/2"-#6 Threaded		4
14	016371	Solenoid Kit, 200A 12V SPST Cont. Duty		1
	015470	Solenoid, 200A 12V SPST Cont. Duty	Available in assemblies only.	1
	015426	Diode Assembly, Solenoid Coil Chassis Gnd		1
15	051346	SWITCH, BLADE START/STOP		1
16	P02575	BOOT, TOGGLE SWITCH RUBBER		1
17	P05251-1	WASHER, 12 X 3/4 X 1/16 NYLON		1
	069343	HARNESS ASSEMBLY, UPPER WIRING (E25 2010)		1
	069307	HARNESS ASSEMBLY, UPPER WIRING (G38 2010)		1

5 **Control & Battery Boxes**
Front Panel Assembly & Harnesses

REF	PART #	DESCRIPTION	COMMENTS	QTY.
	052903	Connector Assembly, Kohler Engine		1
	069309	HARNESS ASSEMBLY, UPPER WIRING (D47 2010)		1
	069306	HARNESS ASSEMBLY, UPPER WIRING (D51 2010)		1
	050399	Conduit, 1 1/4" x 58" Flex		1
	024402	Connector, 1 1/4" Straight Male Metal Conduit		1
	051872	HARNESS ASSEMBLY, LOWER WIRING		1
	R02374	Conduit, 1/2" Expandable Black		41 in.
	R02374	Conduit, 1/2" Expandable Black		42 in.

5.6 Front Panel Assembly & Harnesses (US Only)

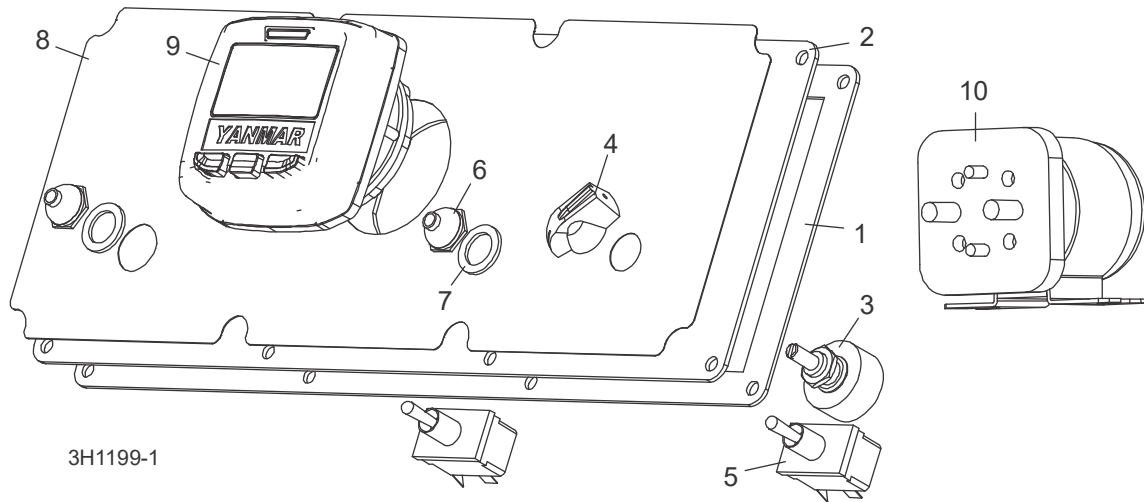

REF	PART #	DESCRIPTION	COMMENTS	QTY.
	073596	PANEL ASSEMBLY, LT40 SUPER TIER 4 FRONT (D35)		1
1	015270	Gasket, Front Panel		1
2	011298	Panel, LT40/50 Control Box Front		1
3	024450	Pot Assembly, Feed Rate Control Sawmill		1
4	P06257	Knob, Feed Rate With Set Screw		1
5	024200	Switch, Toggle		2
6	P02575	Boot, Toggle Switch Rubber		2
7	P05251-1	Washer, 1/2 x 3/4 x 1/16 Nylon		2
8	073593	Decal, Yanmar Tier 4 Control Panel Front		1
9	073601	Controller, Yanmar Tier 4 Engine		1
10	016371	SOLENOID KIT, 200A 12V SPST CONT. DUTY		1
	015470	Solenoid, 200A 12V SPST Cont. Duty	Available in assemblies only.	1
	015426	Diode Assembly, Solenoid Coil Chassis Gnd		1
	073591	HARNESS, LT40/50NR D47 UPPER 2010		1
	050399	Conduit, 1 1/4" x 58" Flex		1
	024402	Connector, 1 1/4" Straight Male Metal Conduit		1
	051872	HARNESS ASSEMBLY, LOWER WIRING		1
	R02374	Conduit, 1/2" Expandable Black		41 in.
	R02374	Conduit, 1/2" Expandable Black		42 in.

5.7 Battery Box Assembly

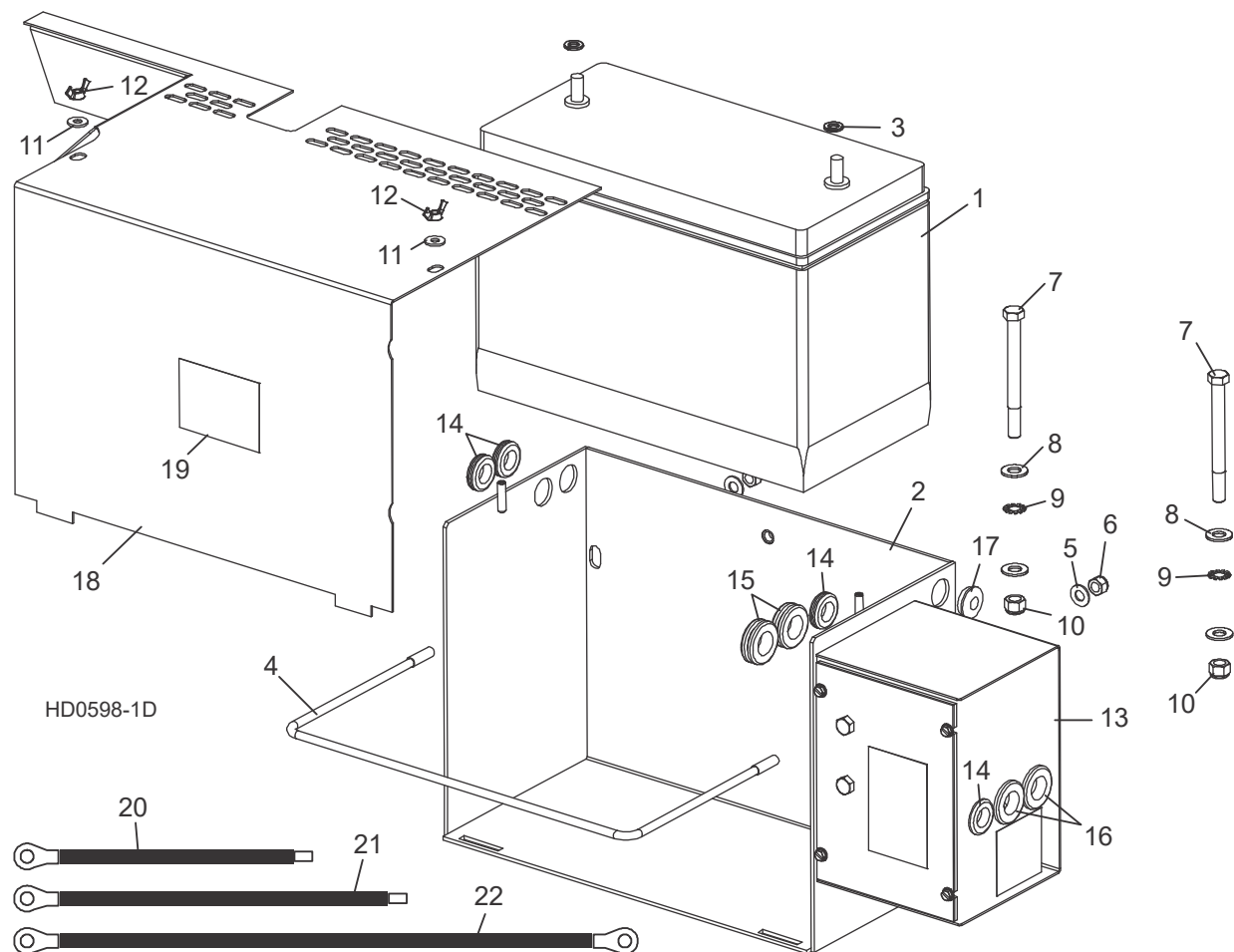

REF	PART #	DESCRIPTION	COMMENTS	QTY.
1	025841	BATTERY, 12 VOLT 8A31DTM AGM	Available in assemblies only.	1
	015565	BOX ASSEMBLY, SUPER HYDRAULIC BATTERY		1
2	015191	Box Weldment, Battery		1
3	F05011-13	Washer, 5/16 Split Lock		2
4	015194	Retainer Loop, Battery		1
5	F05011-17	Washer, 5/16" SAE Flat		2
6	F05010-58	Nut, 5/16-18 Hex Nylon Lock		2
7	F05007-4	Bolt, 3/8-16 X 4" Hex Head Grade 2		2
8	F05011-3	Washer, 3/8" SAE Flat		2
9	F05011-36	Washer, 3/8" External Star		2
10	F05010-10	Nut, 3/8" Hex Nylon Lock		2
11	F05011-11	Washer, 1/4" SAE Flat		2
12	F05010-13	Nut, 1/4-20 Wing		2
13	N/A	Fuse Box Parts	(See Section 5.8)	1
	N/A	Hydraulic Positive Contact Parts	(See Section 9.3)	1
14	P11764	Grommet, 5/8" Rubber Wire		4
15	074198	Grommet, 3/4" ID 11 Gauge Thickness		2
16	074199	Grommet, 3/4" ID 16 Gauge Thickness		2

REF	PART #	DESCRIPTION	COMMENTS	QTY.
17	052496	Plug, 1/2" Knockout Nylon		1
18	015771	LID WELDMENT, BATTERY BOX SUPER		1
19	014774	DECAL, BATTERY BOX LID CAUTION		1
20	036308	CABLE ASSEMBLY, 1 GA X 12" 150A FUSE TO BATTERY POSITIVE		1
21	036309	CABLE ASSEMBLY, 1 GA X 16" 225A FUSE TO BATTERY POSITIVE		1
22	036306	CABLE ASSEMBLY, 1 GA X 26" BATTERY NEGATIVE TO NEG. CONTACT		1

5.8 Fuse Box Assembly

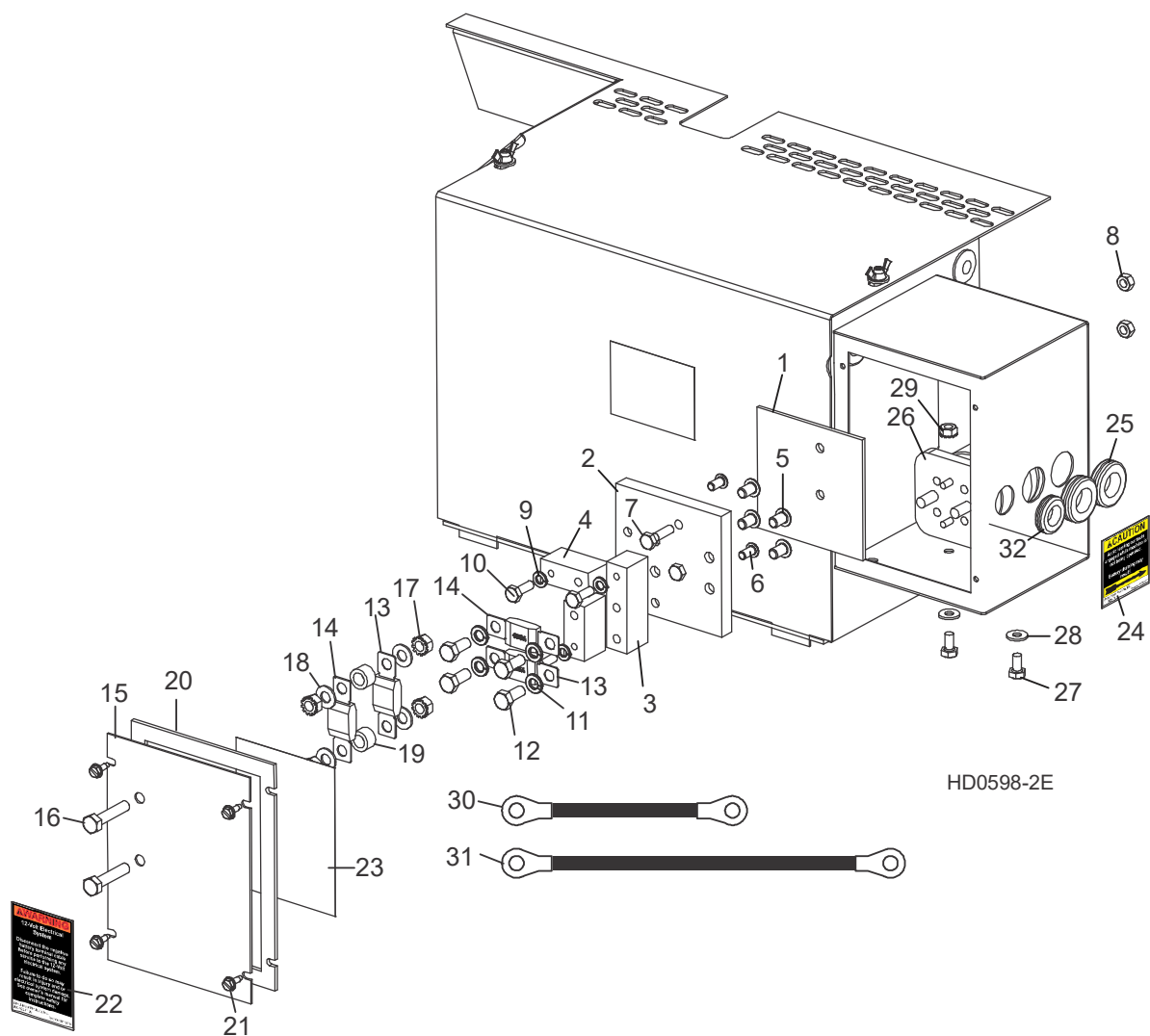

REF	PART #	DESCRIPTION	COMMENTS	QTY.
	006795	BLOCK ASSEMBLY, DOUBLE FUSE		1
1	056999	Plate, Fuse Block Insulator		1
2	056997	Block, Fuse Mount	Available in assemblies only.	1
3	056996	Block, 3/4" Upper Fuse		1
4	056998	Block, 3/4" Lower Fuse		2
5	F05006-20	Screw, 5/16-18 x 1/2" Socket Button Head		4
6	F05005-59	Screw, 1/4-20 x 1/2" Socket Button Head		2
7	F05005-101	Bolt, 1/4-20 x 1" Hex Head Grade 5		2
8	F05010-21	Nut, 1/4-20 Hex Lock		2
9	F05011-14	Washer, 1/4" Split Lock		3
10	F05005-123	Bolt, 1/4-20 x 3/4" Hex Head Grade 5		3
11	F05011-13	Washer, 5/16" Split Lock		4
12	F05006-102	Bolt, 5/16-18 x 3/4" Hex Head Grade 5		4
13	053339	FUSE, 225A 32V MEGA		2
14	053340	FUSE, 450A 32V MEGA		2
	006853	COVER ASSEMBLY, DOUBLE FUSE BOX		1
15	006851	Cover, Fuse Box		1

REF	PART #	DESCRIPTION	COMMENTS	QTY.
16	F05006-2	Bolt, 5/16-18 x 1 1/2" Hex Head Full Thread		2
17	F05010-20	Nut, 5/16-18 Hex Self-Locking		4
18	F05011-17	Washer, 5/16" SAE Flat		4
19	055323	Spacer, .39" x .625" x .39"		2
20	050283	Gasket, Fuse Box Cover		1
21	F05015-7	SCREW, #10-24 X 1/2" SELF-TAPPING		4
22	P10364	DECAL, 12 VOLT WARNING		1
23	006868	DECAL, 225/450A MEGA FUSE ID		1
24	P12960	DECAL, HYDRAULIC CONTACT CAUTION		1
25	074199	GROMMET, 3/4" ID 16 GAUGE THICKNESS		2
26	016371	SOLENOID KIT, 200A 12V SPST CONT. DUTY		1
	015470	Solenoid, 200A 12V SPST Cont. Duty	Available in assemblies only.	1
	015426	Diode Assembly, Solenoid Coil Chassis Ground		1
	024451	WIRE ASSEMBLY, HYDRAULIC SOLENOID VOLTAGE DROP		1
27	F05005-15	BOLT, 1/4-20 X 1/2" HEX HEAD		2
28	F05011-11	WASHER, 1/4" SAE FLAT		2
29	F05010-9	NUT, 1/4-20 SELF-LOCKING HEX		2
30	036305	CABLE ASSEMBLY, 1 GA X 6 1/2" FUSE TO SOLENOID		1
31	036307	CABLE ASSEMBLY, 1 GA X 14" SOLENOID TO POSITIVE CONTACT		1
32	P11764	GROMMET, 5/8" ID RUBBER		1

SECTION 6 UP/DOWN SYSTEM

6.1 Saw Head Mount

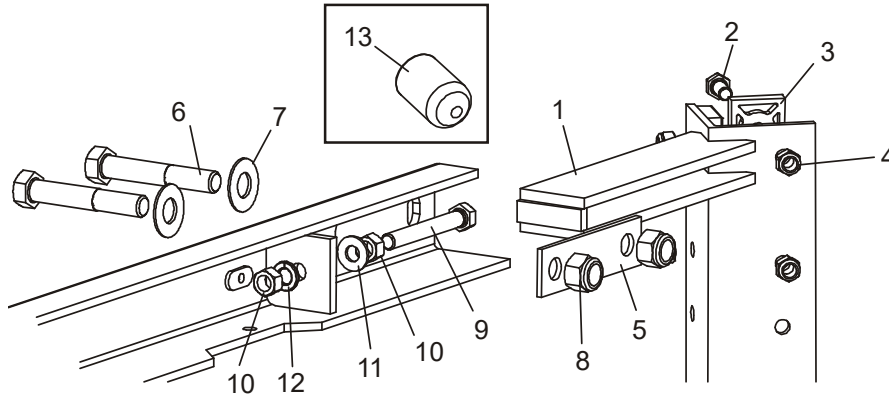

SM0080D

REF	PART #	DESCRIPTION	COMMENTS	QTY.
1	W04099	V-BRACE, SAW HEAD MOUNT		1
2	F05006-5	BOLT, 5/16-18 X 3/4" HEX HEAD GRADE 5		12
	F05006-93	BOLT, 5/16-18 X 1 1/4 HEX HEAD FULL THREAD GRADE 5		4
3	M04096	PAD, PLASTIC SLIDE		6
	016241	PAD, PLASTIC SLIDE LOWER W/CHAMFER		2
4	F05010-58	NUT, 5/16-18 NYLON LOCK		16
5	S07935	PLATE, V-BRACE WASHER		2
6	F05008-61	BOLT, 1/2-13 X 3 1/2" HEX HEAD GRADE 5		4
7	F05011-2	WASHER, 1/2" SAE FLAT		4
8	F05010-8	NUT, 1/2-13 NYLON LOCK		4
9	F05007-17	BOLT, 3/8-16 X 2" FULL THREAD		2
10	F05010-1	NUT, 3/8-16 HEX		4
11	F05011-3	WASHER, 3/8" SAE FLAT		2
12	F05011-4	WASHER, 3/8" SPLIT LOCK		2
13	017715	CAP, .281" X 1/2" BLACK VINYL		3

6.2 Blade Height & Quarter Scales

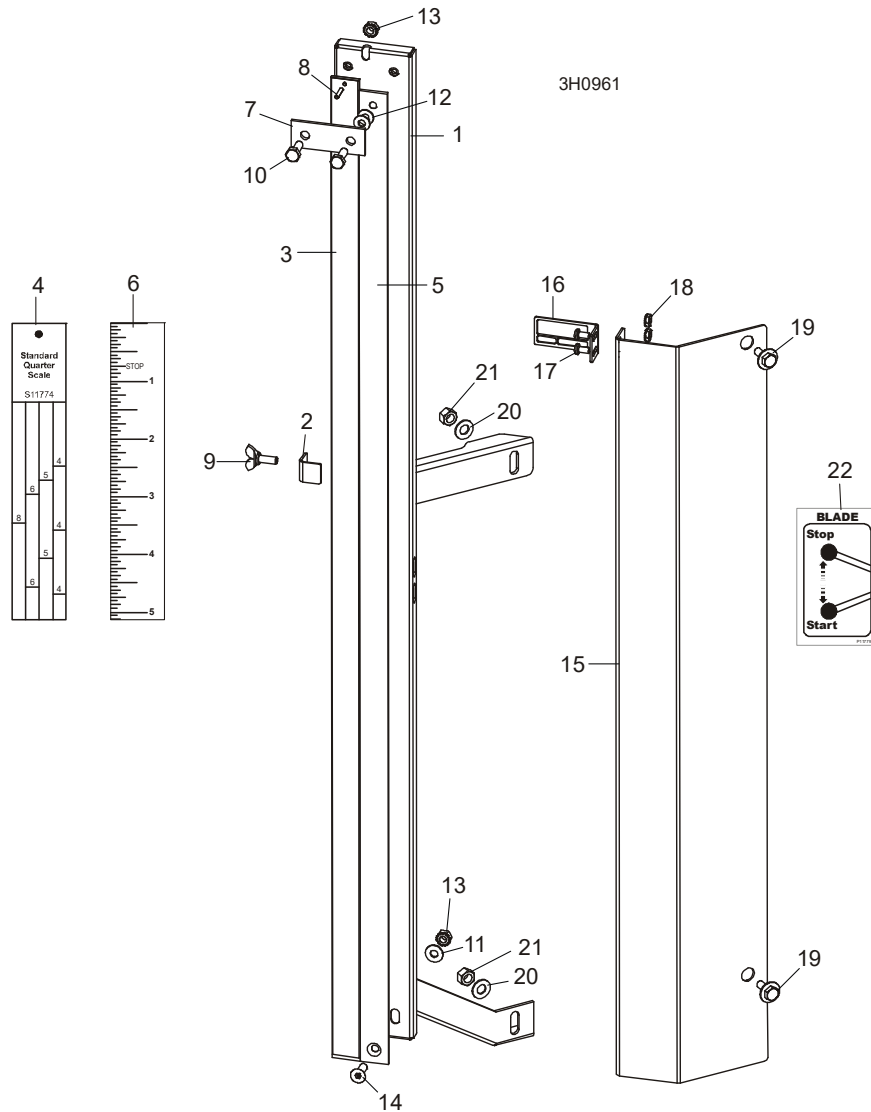

REF	PART #	DESCRIPTION	COMMENTS	QTY.
	K11998	Scale Kit, Fixed With Pointer	Service kit	1
	A12022	Scale Assembly, Fixed	Available in assemblies only.	1
1	W11996	Bracket, Scale Mounting		1
2	036666	Plate, Movable Scale Stop		1
3	S11989	Scale, 35" Quarter		1
4	S11774	Decal, 35" Standard Quarter Scale		1
	P12819	Decal, 35" Grade Hardwood Quarter Scale		1
5	S11988	Scale, 35" Inch		1
6	S11773	Decal, 35" Inch		1
7	S04805	Strap, Scale Hold-Down		1
8	F05012-14	Pin, 1/8" X 5/8" Roll		1
9	F05005-64	Screw, 1/4-20 X 5/8" Wing		1
10	F05005-1	Bolt, 1/4-20 x 1/2" Hex Head		2
11	F05011-11	Washer, 1/4" SAE Flat		1
12	F05011-22	Washer, 1/4" X .020 Thick Nylon Flat		2
13	F05010-9	Nut, 1/4-20 Hex Self-Locking		2

REF	PART #	DESCRIPTION	COMMENTS	QTY.
14	F05005-70	Screw, 1/4-20 X 3/4" Flat Socket Head		1
	038591	Pointer Assembly, Fixed Scale		1
15	038586	Bracket, Fixed Scale Pointer Mount		1
16	038585	Pointer, Fixed Scale		1
17	F05004-3	Screw, #10-24 X 3/8" Phillips Head		2
18	F05010-14	Nut, #10-24 Hex Self-Locking		2
19	F05005-134	Bolt, 1/4-20 x 3/4" with Conical Washer		2
20	F05011-17	Washer, 5/16" SAE Flat		2
21	F05010-6	Nut, 5/16-18 Hex Lock		2
	F05005-15	Bolt, 1/4-20 X 1/2" Hex Head Grade 2		1
	A12030-370	Instruction Sheet, Fixed Scale Retrofit		1
	K12064	Decal Kit, Metric Scale		1
	S11711	Decal, Metric		1
	P12040-1	Decal, Metric 16-40mm		1
	P12040-2	Decal, Metric 45-63mm		1
22	P11779	Decal, Clutch Handle Operation		1

6.3 Up/Down Chain & Sprockets

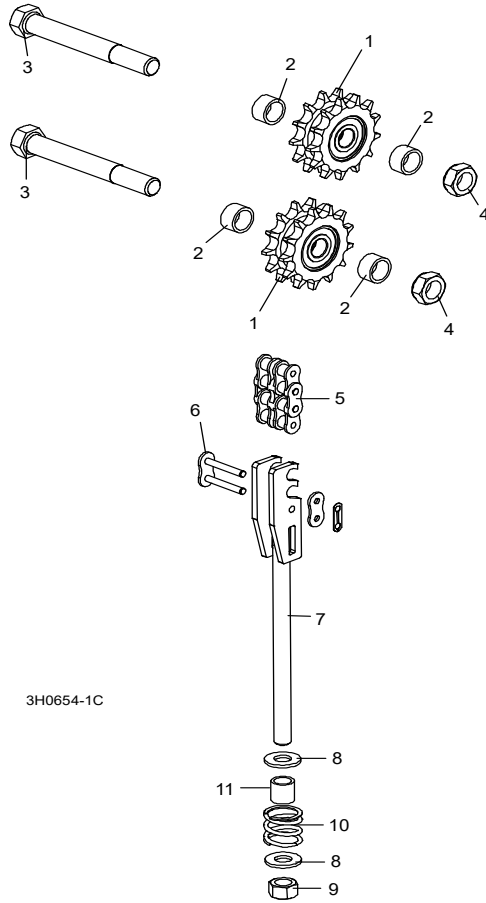

REF	PART #	DESCRIPTION	COMMENTS	QTY.
	016020	SPROCKET KIT, UP/DOWN IDLER #50-2		1
1	016019	Sprocket, Up/Down Idler '98		2
2	016018	Spacer, 50-2 Idler '98		4
	016020-541	Instruction Sheet, Up/Down Idler Retrofit		1
3	F05009-6	BOLT, 5/8-11 X 5" HEX HEAD GRADE 2		2
4	F05010-96	NUT, 5/8-11 JAM NYLON LOCK		2
5	015259	CHAIN, #50-2 X 75.625" UP/DOWN		1
6	015258	LINK, #50-2 MASTER		2
	015456	TENSIONER ASSEMBLY, UP/DOWN CHAIN		1
7	015188	Bracket, Up/Down #50 Chain Tensioner	Available in assemblies only.	1
8	F05011-2	Washer, 1/2" SAE Flat		2
9	F05010-8	Nut, 1/2-13 Hex Nylon Lock		1
10	016516	Spring, 1" OD x 1" Long x .125" Wire Compr.		1
11	016515	Spacer, Up/Dn Chain Tensioner		1

6.4 Up/Down Motor Assembly

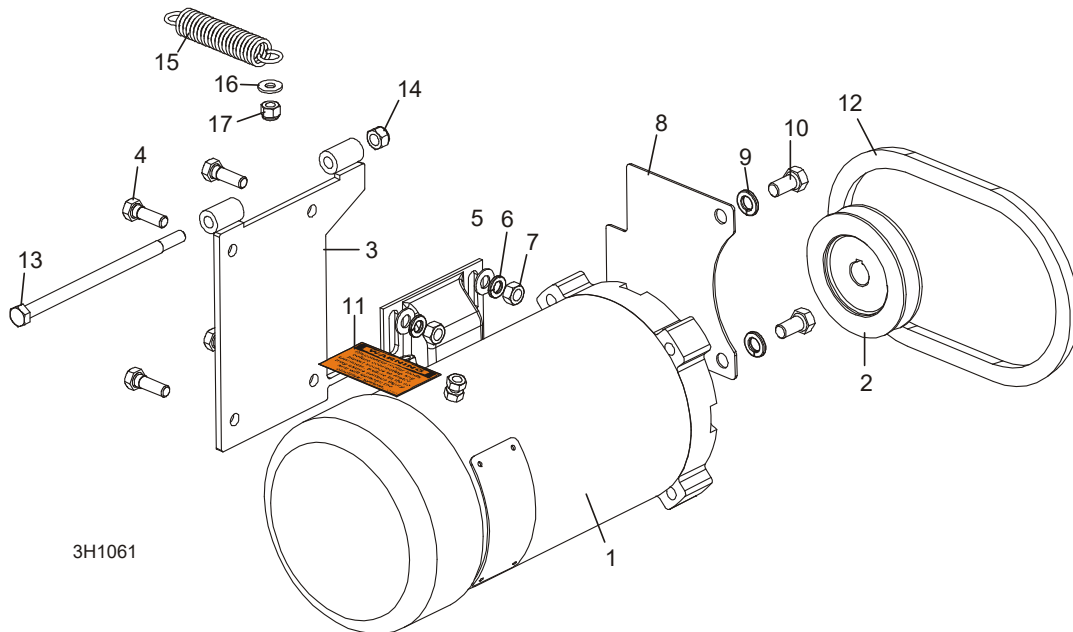

REF	PART #	DESCRIPTION	COMMENTS	QTY.
1 - 11	008779	UP/DOWN MOTOR ASSEMBLY		1
1	053682	Motor, 1HP 12VDC Electric		1
	053682-BK	Brush Kit, Leeson 1HP Motor		1
2	008999	Pulley, AK32 x 5/8"		1
3	015198	Bracket, Up/Down Motor Mount		1
4	F05006-1	Bolt, 5/16-18 x 1" Hex Head		4
5	F05011-17	Washer, 5/16" SAE Flat		4
6	F05011-13	Washer, 5/16" Split Lock		4
7	F05010-17	Nut, 5/16-18 Hex		4
8	015016	Guard, Up/Down Sprocket		1
9	F05011-4	Washer, 3/8" Split Lock		2
10	F05007-27	Bolt, 3/8-16 x 3/4" Hex Head		2
11	024431	Decal, Disconnect Motor Leads Warning		1
12	038459	BELT, 4L245 NOTCHED		1
13	F05006-73	BOLT, 5/16-18 X 6" HEX HEAD GRADE 5		1
14	F05010-65	NUT, 5/16-18 HEX NYLON LOCK		1
15	015569	SPRING, .75" X 3 3/4" X .092" EXTENSION		1
16	F05011-11	WASHER, 1/4" SAE FLAT		1
17	F05010-69	NUT, 1/4-20 NYLON LOCK HEX		1

6.5 Up/Down Drive Assembly

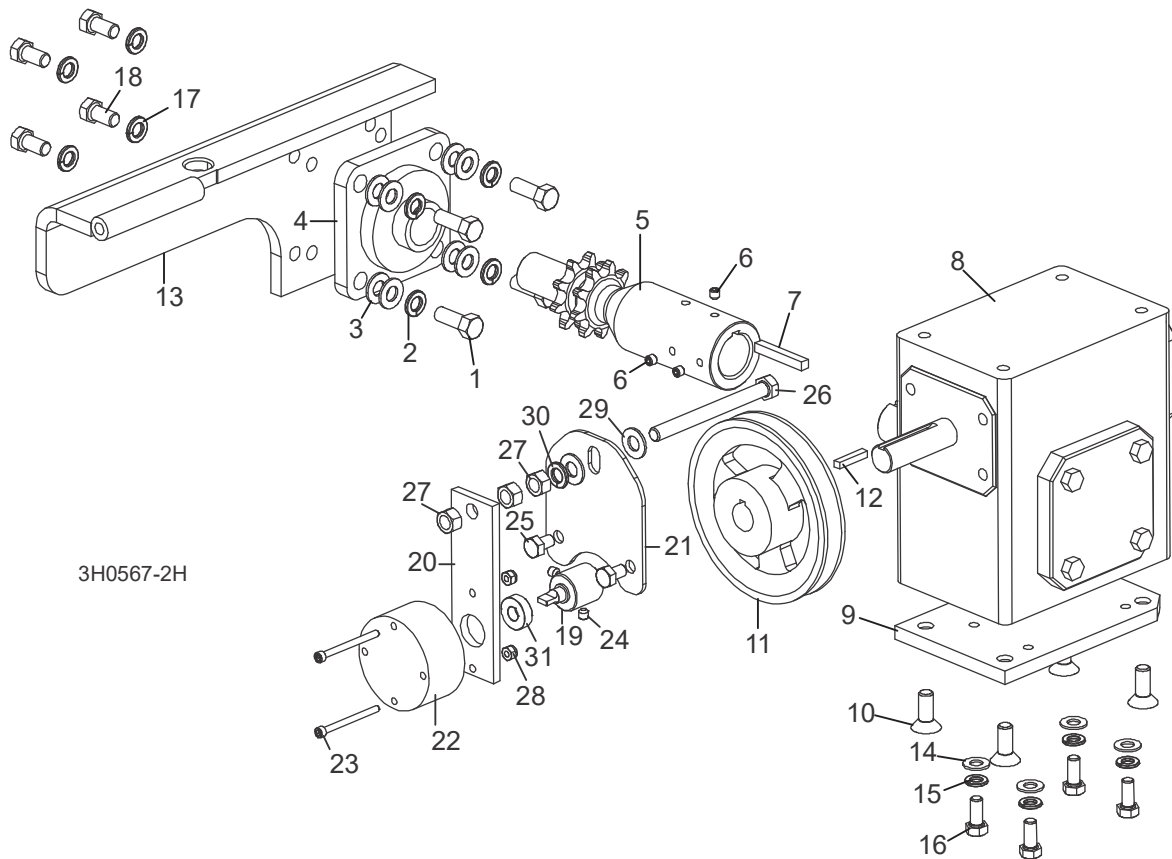

REF	PART #	DESCRIPTION	COMMENTS	QTY.
	015176	UP/DOWN DRIVE ASSEMBLY		1
1	F05007-7	Bolt, 3/8-16 x 1" Hex Head		4
2	F05011-4	Washer, 3/8" Split Lock		4
3	F05011-3	Washer, 3/8" SAE Flat		8
4	014090	Bearing, Flanged Up/Down		1
	016094	Shaft Kit, Up/Down Drive		1
5	016031	Shaft, Up/Down Sprocket	Available in assemblies only.	1
6	F05005-105	Screw, 1/4-28 x 1/4" Socket Head Cup Point		3
7	S04124	Key, 1/4" Square x 1 11/16" Long		1
8	074124	Gear Box, Up/Down Grove		1
9	014158	Plate, Gear Box Spacer		1
10	F05007-64	Bolt, 3/8-16 x 1" Flat Socket Head		4
11	015256	Pulley, Up/Down		1
12	S31027	Key, 3/16" Square x 1" Long		1
13	015195	Bracket, Up/Down Motor Mount		1
14	F05011-17	WASHER, 5/16" SAE FLAT		4
15	F05011-13	WASHER, 5/16" SPLIT LOCK		4
16	F05006-102	BOLT, 5/16-18 X 3/4" HEX HEAD GRADE 5		4
17	F05011-4	WASHER, 3/8" SPLIT LOCK		4
18	F05007-27	BOLT, 3/8-16 X 3/4" HEX HEAD		4
	L04869-4	OIL, 8 OZ. MOBIL SHC634 BOTTLED SYN-THETIC GEAR	24 oz. required for complete oil replacement.	1

REF	PART #	DESCRIPTION	COMMENTS	QTY.
	065187	BRAKE ASSEMBLY, SUPER UP/DOWN		1
19	062511	Shaft, Up/Down Brake LT70 3/4"		1
20	062513	Plate, Brake Mount		1
21	065190	Plate, Super Up/Down Brake Mount		1
	065907	Brake Assembly, LT40/50/70 Up/Down Replacement		1
22	069519	Brake, Klauber Gearmotor #K01134D300	Available in assemblies only.	1
	F05708-26	Terminal, 3/16" 18-22 Ga Quick Male		2
23	F05004-273	Bolt, #8-32 x 2" Socket Head Stainless Steel		2
24	F05005-131	Screw, 1/4-20 x 1/4" Cup Point Socket Set		2
25	F05006-15	Bolt, 5/16-18 x 1/2" Hex Head Grade 5		2
26	F05007-92	Bolt, 3/8-16 x 4" Hex Head Full Thread Grade 5		1
27	F05010-1	Nut, 3/8-16 Hex		3
28	F05010-169	Nut, #8-32 Hex Nylon Lock		2
29	F05011-3	Washer, 3/8" SAE Flat		2
30	F05011-4	Washer, 3/8" Split Lock		1
31	P10688	Bearing, R6-2NSL SRI-2 ABEC-1		1
	069678-S-FR	Diode OR Assembly, Up/Down Brake LT40/50		1

SECTION 7 FEED SYSTEM & TRACK ROLLERS

7.1 Upper Track Rollers And Wipers

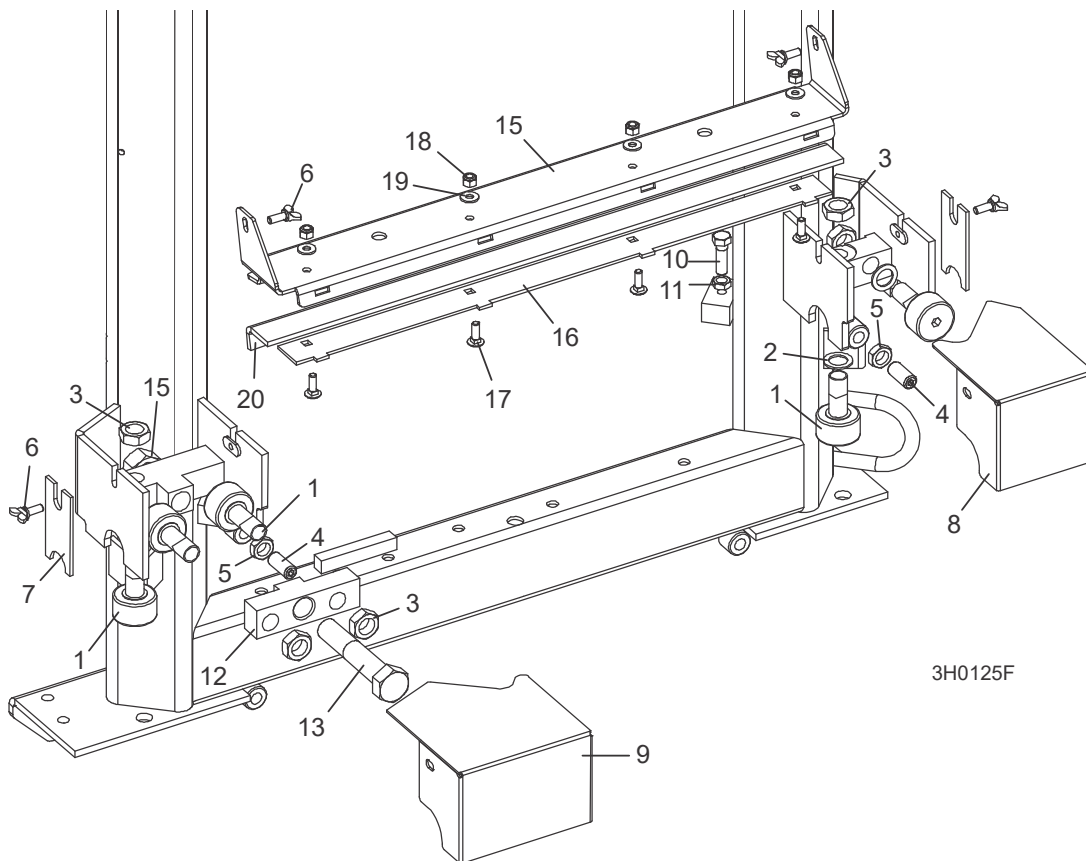

REF	PART #	DESCRIPTION	COMMENTS	QTY.
1	012797	ROLLER, TRACK CAM BEARING		5
2	016510	SHIM, 5/8" X 1" X .062"		2
3	F05010-11	NUT, 5/8-18 HEX JAM		5
4	F05008-5	SCREW, 1/2-13 X 1 1/4" OVAL POINT SET		2
5	F05010-31	NUT, 1/2-13 HEX JAM		2
6	F05005-64	SCREW, 1/4-20 X 5/8" THUMB		4
7	M04113	WIPER, PLASTIC TRACK		2
8	012999	HOUSING, UPPER TRACK ROLLER REAR		1
9	016285	HOUSING, UPPER TRACK ROLLER FRONT		1
10	F05007-2	BOLT, 3/8-16 X 1 1/4" HEX HEAD		2
11	F05010-29	NUT, 3/8-16 HEX JAM		2
12	016501	BLOCK, UPPER ROLLER PIVOT		1
13	F05013-3	BOLT, 3/4-10 X 4" HEX HEAD GRADE 5		1
14	F05010-80	NUT, 3/4-10 SELF LOCKING		1
	110612	COVER ASSEMBLY, LT40 TRACK		1
15	110609	Cover, Middle Track, LT40	Available in assemblies only.	1
16	110611	Retainer, Felt Oiler	Available in assemblies only.	1
17	F05005-113	Bolt, 1/4-20x3/4 Carriage		4
18	F05010-69	Nut, 1/4-20 Nylock		4
19	F05011-11	Washer, 1/4 SAE Flat		4
20	S09915	Felt, Middle Track Oiler LT40/50/70		1

7.2 Power Feed Assembly

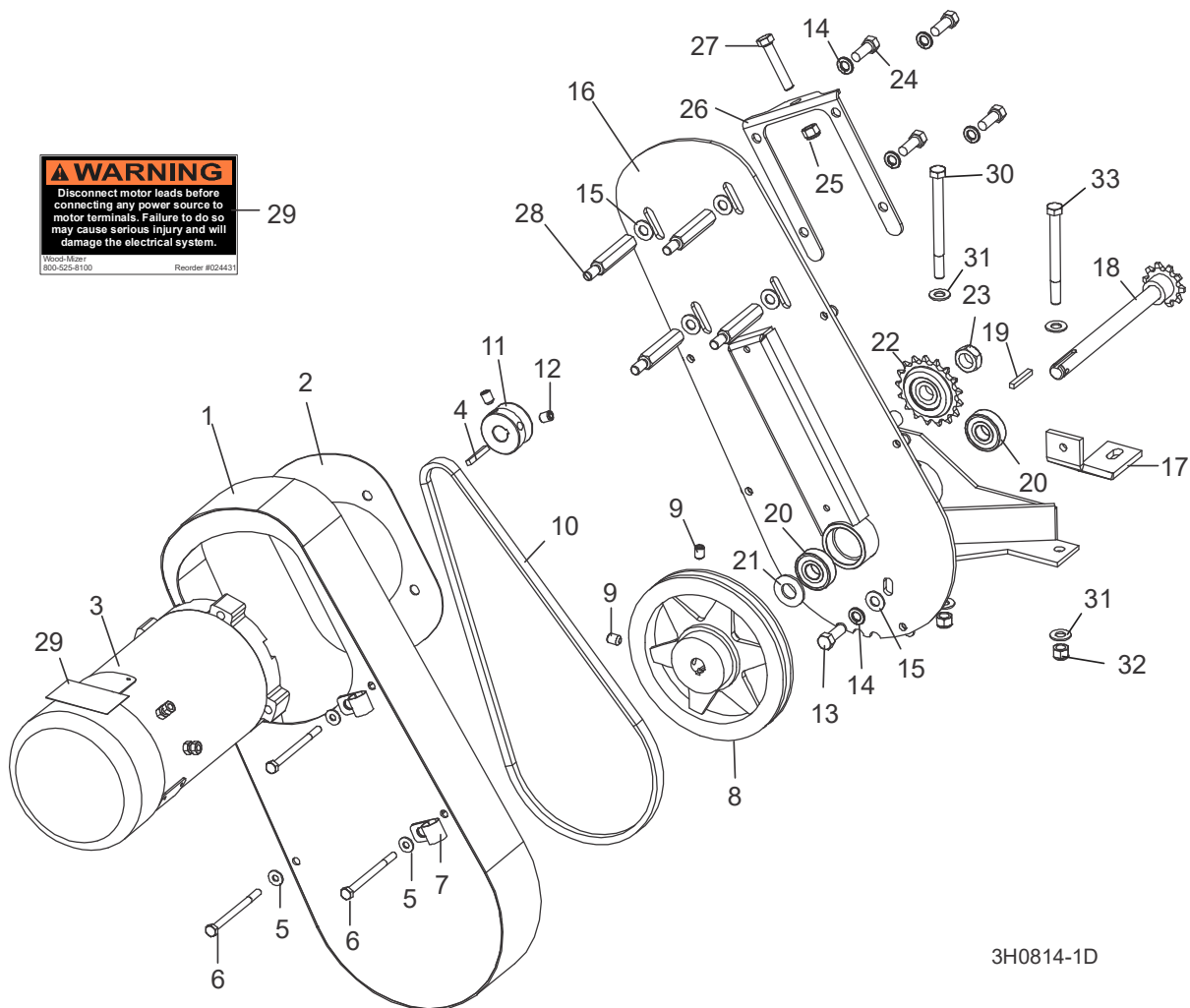

REF	PART #	DESCRIPTION	COMMENTS	QTY.
	015125	POWER FEED ASSEMBLY		1
1	015126	Cover Weldment, Top Power Feed		1
2	015133	Plate, Power Feed Motor		1
3	024169	Motor, 3/4HP Power Feed Painted		1
	024167	Brush Kit, Leeson 3/4HP Motor (Includes 2 Brushes and 2 Springs)		1
	016087	Fan, 3/4 HP Leeson Motor Replacement		1
	061146	Guard, Motor Fan Leeson 3/4HP		1
4	S31027	Key, 3/16" Square x 1" Long		1
5	F05011-11	Washer, 1/4" SAE Flat		4
6	F05005-54	Bolt, 1/4-20 X 3 1/2" Hex Head Grade 2		4
7	010748	Clamp, 5/8" EMT Coated		2
8	016088	Sheave, AK71 x 5/8" Power Feed (200ft./min.)	To increase feed return rate to 220 ft./min. replace with AK64 sheave 016114 and AX35 belt 015175 (replaces kit 016085). Kit 016070, AL84 x 5/8" Sheave 016115 and AX38 Belt 016068 to reduce feed return rate to 183 ft./min. no longer available.	1
9	F05006-32	Screw, 5/16-18 x 3/4" Cup Point Set		2

REF	PART #	DESCRIPTION	COMMENTS	QTY.
10	016083	Belt, AX36 (200ft./min.)	To increase feed return rate to 220 ft./min. replace with AK64 sheave 016114 and AX35 belt 015175 (replaces kit 016085). Kit 016070, AL84 x 5/8" Sheave 016115 and AX38 Belt 016068 to reduce feed return rate to 183 ft./min. no longer available.	1
11	015135	Sheave, 1 3/4" Feed Motor		1
12	F05007-12	Screw, 3/8"-16 x 1/2" Cup Point Set		2
13	F05007-7	Bolt, 3/8-16 x 1" Hex Head		1
14	F05011-4	Washer, 3/8" Split Lock		5
15	F05011-3	Washer, 3/8" Flat		5
16	015162	Bracket, Power Feed Mount		1
17	015132	Brace, Power Feed Mounting		1
	016066	Shaft Assembly, Power Feed with Key		1
18	015129	Shaft Weldment, Power Feed	Available in assemblies only.	1
19	016108	Key, 3/16" Square x 1 3/8" Long		1
20	P06030-1	Bearing, 5/8" 6203-2NSL		2
21	F05011-19	Washer, 5/8" x 15/16" x .094" Nylon		1
22	016366	Sprocket, #40/41 Idler 17T 5/8" ID w/Bearing		1
23	F05010-96	Nut, 5/8-11 Nylon Lock Jam		1
24	F05007-27	Bolt, 3/8-16 x 3/4" Hex Head		4
25	F05010-10	Nut, 3/8-16 Hex Nylon Lock		1
26	015134	Plate, Belt Tensioner		1
27	F05007-16	Bolt, 3/8-16 x 2" Full Thread Hex Head		1
28	015136	Spacer, Power Feed Motor		4
29	024431	Decal, Disconnect Motor Leads Warning		1
30	F05007-35	BOLT, 3/8-16 X 4 1/2" HEX HEAD		1
31	F05011-3	WASHER, 3/8" SAE FLAT		4
32	F05010-10	NUT, 3/8-16 HEX NYLON LOCK		2
33	F05007-4	BOLT, 3/8-16 X 4" FULL THREAD HEX HEAD TAP GRADE 5		1

7.3 Feed Chain/Stop

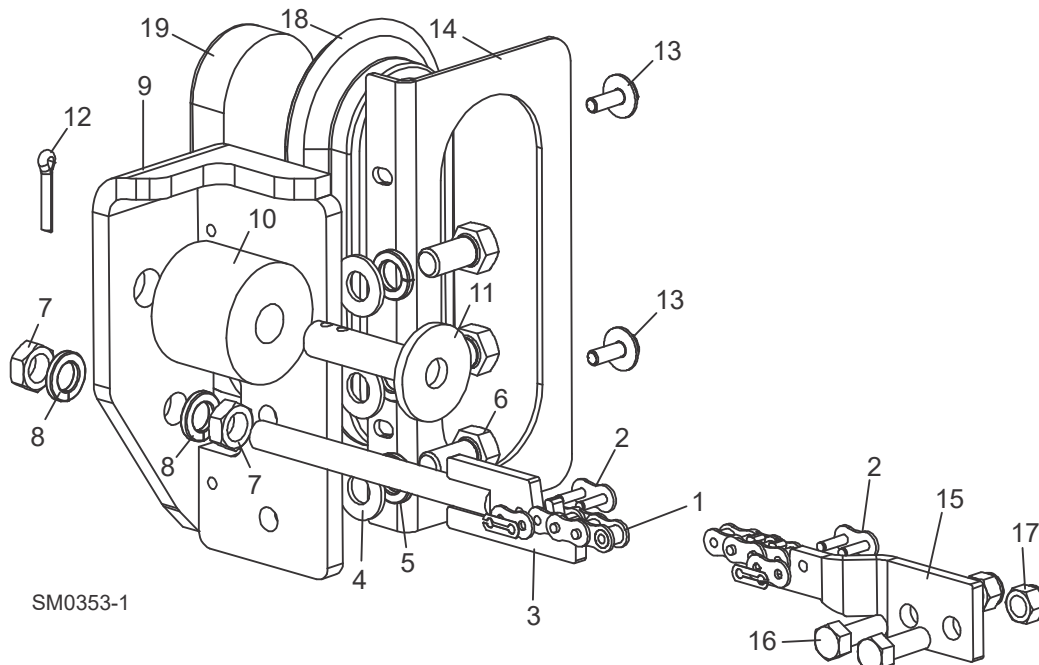

REF	PART #	DESCRIPTION	COMMENTS	QTY.
1	014745	CHAIN, #40 X 267.5" LT40 FEED		1
2	P04200	LINK, #40 MASTER		2
3	015721	TENSIONER WELDMENT, POWER FEED CHAIN		1
4	F05011-2	WASHER, 1/2" SAE FLAT		3
5	F05011-9	WASHER, 1/2" SPLIT LOCK		3
6	F05008-128	BOLT, 1/2-13 X 1" HEX HEAD GRADE 8		3
7	F05010-16	NUT, 1/2-20 HEX JAM		2
8	F05011-9	WASHER, 1/2" SPLIT LOCK		2
9	006686	BRACKET WELDMENT, REAR FEED STOP		1
	K09630	STOP KIT, RUBBER CARRIAGE		2
10	P12165	Stop, Rubber Carriage		1
11	W09293	Pin, Rubber Carriage Stop		1
12	F05012-21	Pin, 3/16" X 1" Cotter		1
13	F05005-134	BOLT, 1/4-20 X 3/4" WITH CONICAL WASHER		1
14	057822	PLATE, BED TUBE END W/LIGHT MOUNT		1
15	015008	BRACKET, FRONT FEED CHAIN MOUNT		1
16	F05007-87	BOLT, 3/8-16 X 1" HEX HEAD GRADE 5		2
17	F05010-10	NUT, 3/8-16 HEX NYLON LOCK		2
18	006688	GROMMET, 6 1/2" LIGHT MOUNTING		1
19	006391	LIGHT, 8 DIODE LED TAIL		1

7.4 Lower Track Rollers

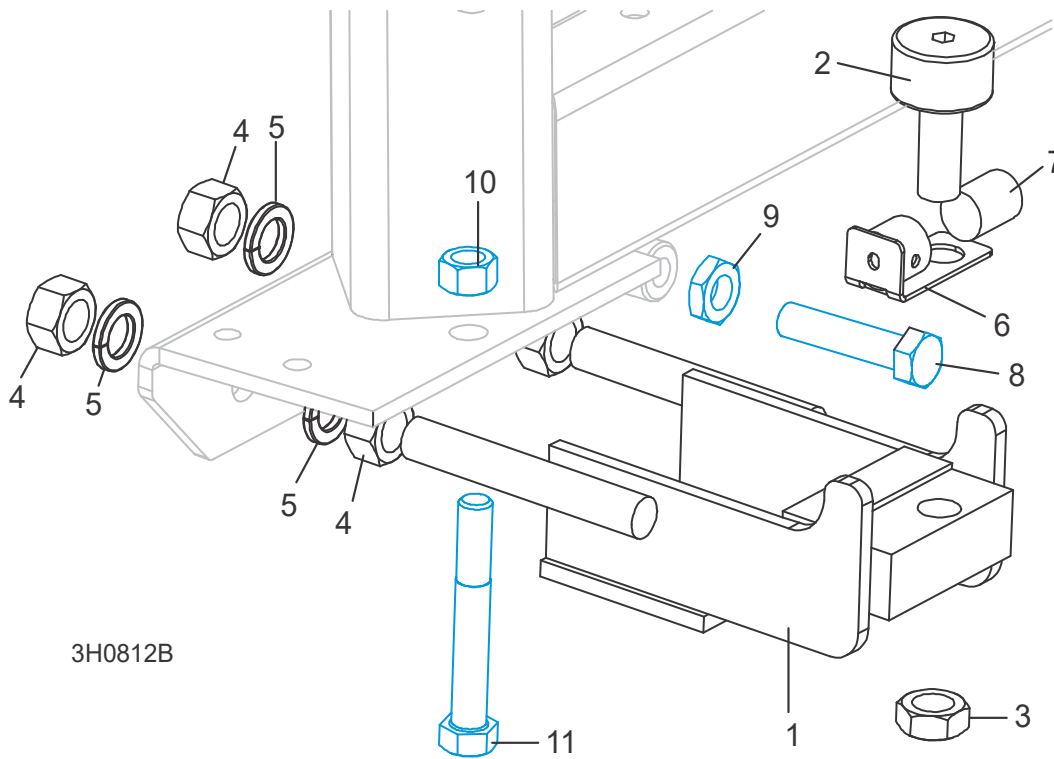

REF	PART #	DESCRIPTION	COMMENTS	QTY.
	012995	ROLLER ASSEMBLY, LOWER TRACK		2
1	012982	Bracket, Lower Track Roller Mounting	Available in assemblies only.	1
2	012797	Roller, Track Cam Bearing		1
3	F05010-11	Nut, 5/8-18 Hex Jam		1
4	F05010-5	Nut, 5/8-11 Hex		4
5	F05011-118	Washer, 5/8" Split Lock Grade 8		4
6	033374	Bracket Weldment, Lower Track Roller Wiper		1
7	033375	Wiper, Round Gray Felt		1
8	F05008-2	BOLT, 1/2-13 X 2 1/4" HEX HEAD FULL THREAD		2
9	F05010-31	NUT, 1/2-13 HEX JAM		2
10	F05010-3	NUT, 1/2-13 HEX LOCK		2
11	F05008-61	BOLT, 1/2-13 X 3 1/2" HEX HEAD GRADE 5		2

SECTION 8 BED FRAME ASSEMBLY

8.1 Bed Rail Assembly, Front And Rear

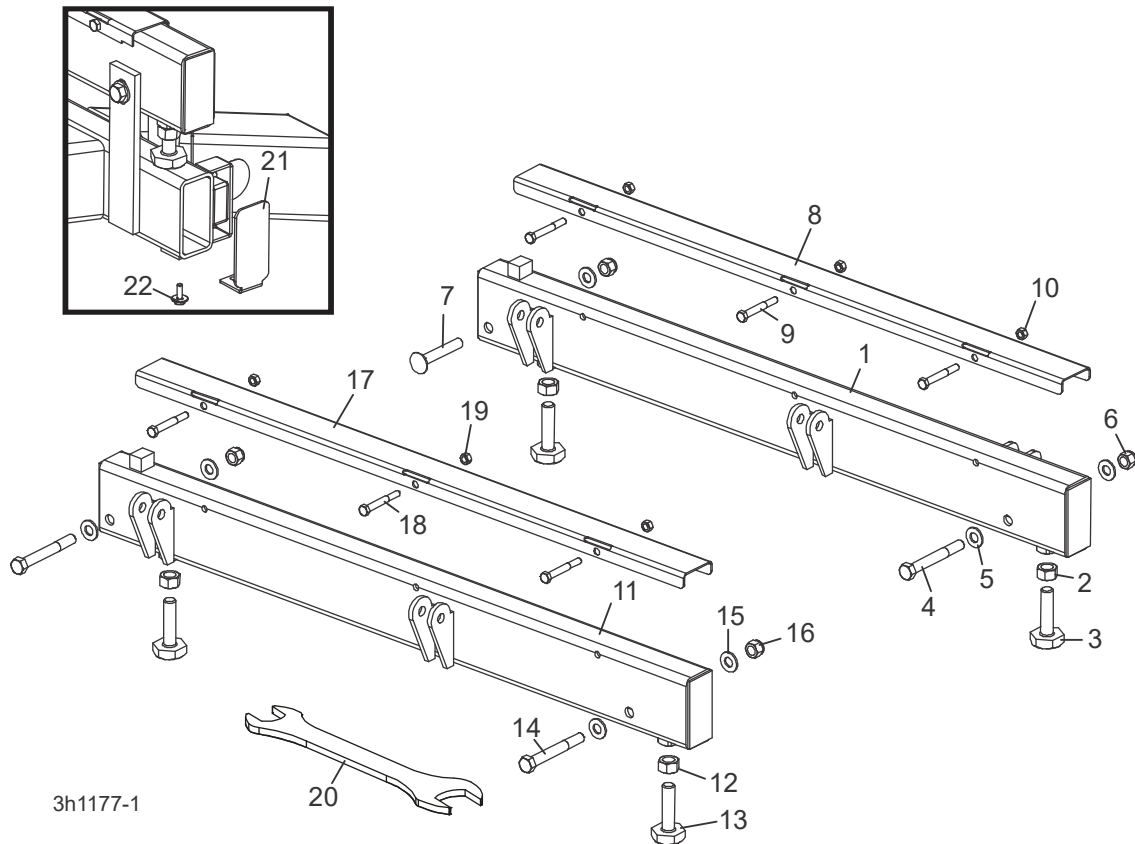

3h1177-1

REF	PART #	DESCRIPTION	COMMENTS	QTY.
	003298	BED RAIL ASSEMBLY, REAR PAINTED (LT50 BED 4)		1
1	034547	Tube Weldment, Bed Rail 4		1
2	F05010-5	Nut, 5/8-11 Hex		2
3	S13006	Bolt, Bed Rail Adjustment		2
4	F05008-78	Bolt, 1/2-13 X 4" Hex Head		1
5	F05011-2	Washer, 1/2" SAE Flat		3
6	F05010-8	Nut, 1/2-13 Nylon Lock		2
7	F05008-94	Bolt, 1/2-13 x 3 1/2" Carriage		1
	079144	Cover Kit, Front/Rear Bed Rail SS		1
8	016898	Cover, Stainless Steel Bed Rail		1
9	F05006-10	Bolt, 5/16-18 X 2 1/2" Hex Head		3
10	F05010-6	Nut, 5/16-18 Hex Lock		3
		Hydraulic Toe Board Parts ()	(See Section 9.10)	
	034548	BED RAIL ASSEMBLY, FRONT PAINTED (LT60/70 BED 1)		1
11	034544	Tube Weldment, Bed Rail 1		1
12	F05010-5	Nut, 5/8-11 Hex		2
13	S13006	Bolt, Bed Rail Adjustment		2
14	F05008-78	Bolt, 1/2-13 X 4" Hex Head		2
15	F05011-2	Washer, 1/2" SAE Flat		4

REF	PART #	DESCRIPTION	COMMENTS	QTY.
16	F05010-8	Nut, 1/2-13 Nylon Lock		2
	079144	Cover Kit, Front/Rear Bed Rail SS		1
17	016898	Cover, Stainless Steel Bed Rail		1
18	F05006-10	Bolt, 5/16-18 X 2 1/2" Hex Head		3
19	F05010-6	Nut, 5/16-18 Hex Lock		3
		Hydraulic Toe Board Parts ()	(See Section 9.10)	
20	015970	WRENCH, BED RAIL ADJUSTMENT	OPTIONAL	1
21	038843	CAP, BED RAIL REMOVABLE END		2
22	F05005-134	BOLT, 1/4-20 X 3/4" W/CONICAL WASHER HEAD		2

8.2 Bed Rail Assembly, Middle Front

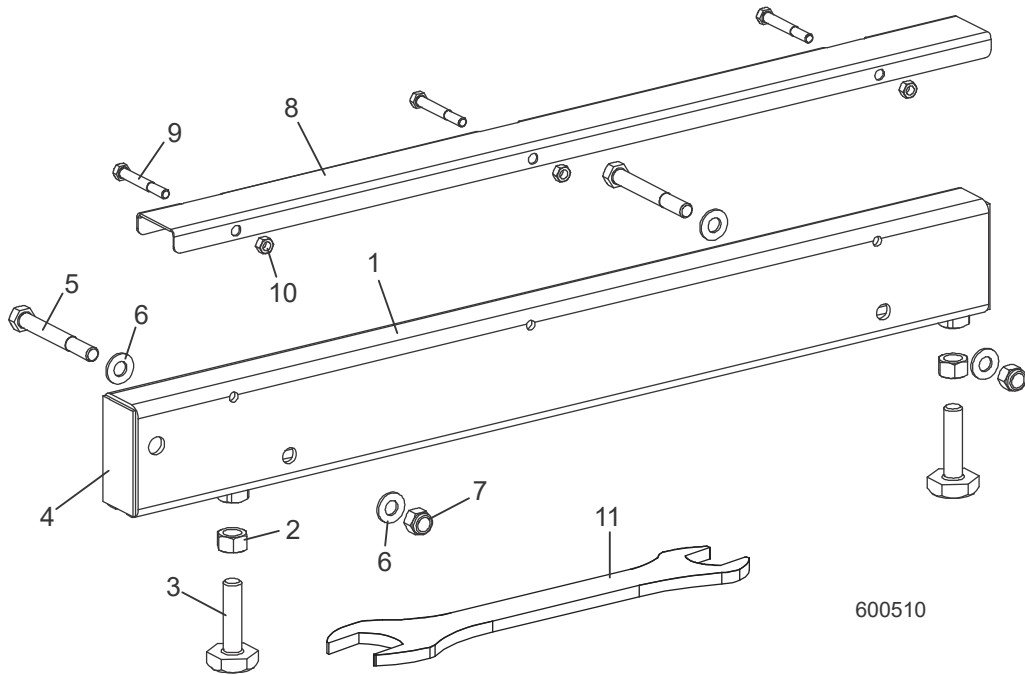

REF	PART #	DESCRIPTION	COMMENTS	QTY.
	034549	BED RAIL ASSEMBLY, FRONT MIDDLE (LT60/70 BED 2)		1
1	034545	Bed Rail Tube, Short	Available in assemblies only.	1
2	F05010-5	Nut, 5/8-11 Hex		2
3	S13006	Bolt, Bed Rail Adjustment		2
4	S04058	Plate, Bed Rail End Cap	Available in assemblies only.	2
5	F05008-78	Bolt, 1/2-13 X 4" Hex Head Grade 5		2
6	F05011-2	Washer, 1/2" SAE Flat		4
7	F05010-8	Nut, 1/2-13 Nylon Lock		2
	A09956	Cover Assembly, Stainless Steel Bed Rail (Long)		1
8	S09944	Cover, Stainless Steel Bed Rail	Available in assemblies only.	1
9	F05006-10	Bolt, 5/16-18 X 2 1/2" Hex Head		3
10	F05010-6	Nut, 5/16-18 Hex Lock		3
11	015970	WRENCH, BED RAIL ADJUSTMENT		1

8.3 Bed Rail Assembly, Middle Rear

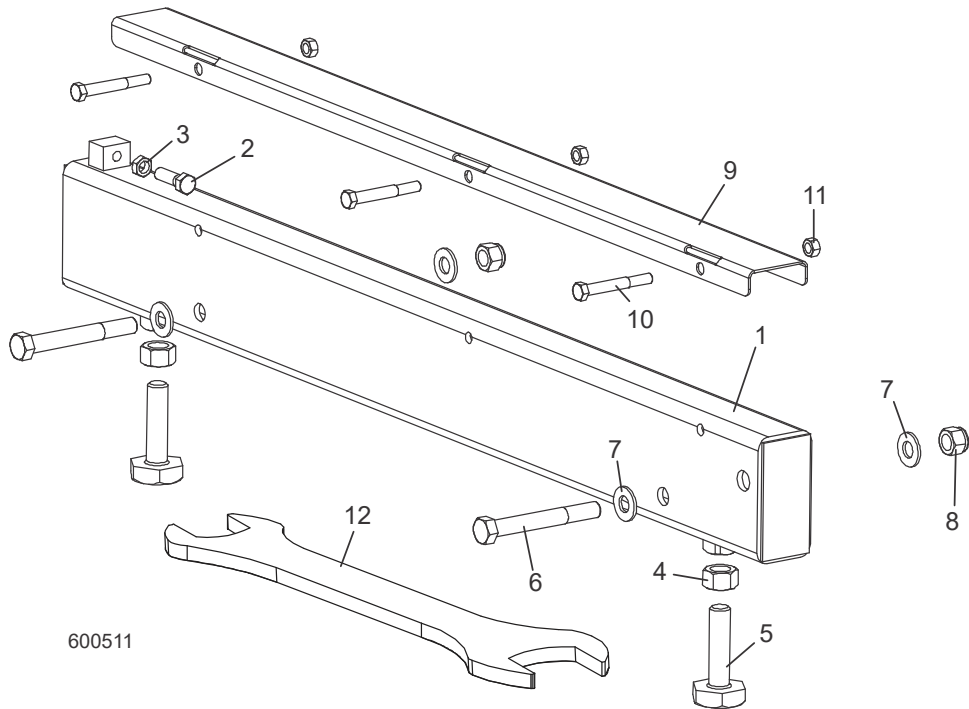

REF	PART #	DESCRIPTION	COMMENTS	QTY.
	034550	BED RAIL ASSEMBLY, REAR MIDDLE PAINTED (LT60/70 BED 3)		1
1	034546	Tube Weldment, Bed Rail 3		1
2	F05007-2	Screw, 3/8-16x1 1/4 HHC		1
3	F05010-29	Nut, 3/8-16 Hex Jam		1
4	F05010-5	Nut, 5/8-11 Hex		2
5	S13006	Bolt, Bed Rail Adjustment		2
6	F05008-78	Bolt, 1/2-13 X 4" Hex Head Grade 5		2
7	F05011-2	Washer, 1/2" SAE Flat		4
8	F05010-8	Nut, 1/2-13 Nylon Lock		2
	A09956	Cover Assembly, Stainless Steel Bed Rail (Long)		1
9	S09944	Cover, Stainless Steel Bed Rail	Available in assemblies only.	1
10	F05006-10	Bolt, 5/16-18 X 2 1/2" Hex Head		3
11	F05010-6	Nut, 5/16-18 Hex Lock		3
12	015970	WRENCH, BED RAIL ADJUSTMENT		1

8.4 Fine Adjustable Legs Overview

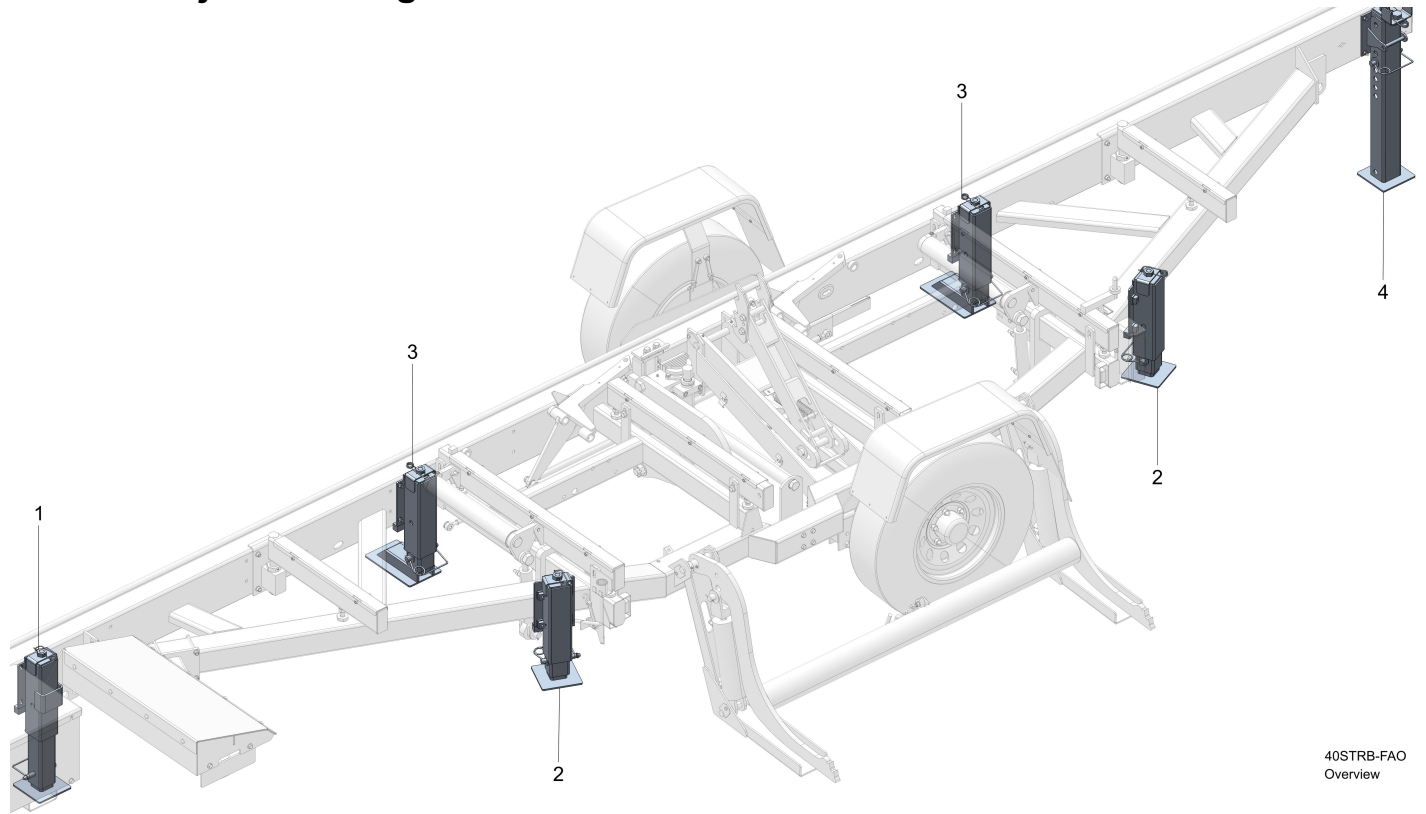

REF	PART #	DESCRIPTION	COMMENTS	QTY.
1	003944	Leg Assembly, Adj. Outrigger Front	See Section 8.5 FAO Outrigger, Front	1
2	056781	Leg Assembly, Loading Side Adjustable	See Section 8.6 FAO Outrigger, Loading Side	2
3	056787	Leg Assembly, Adj Outrigger Offset	See Section 8.7 FAO Outrigger, Offset Leg	2
4	056791	Leg Assembly, Rear Adj. Outrigger	See Section 8.8 FAO Outrigger, Rear	1
			See Form #2540 for Stationary Legs	
			See Form #2541 for Adjustable Legs	

8.5 FAO Outrigger, Front

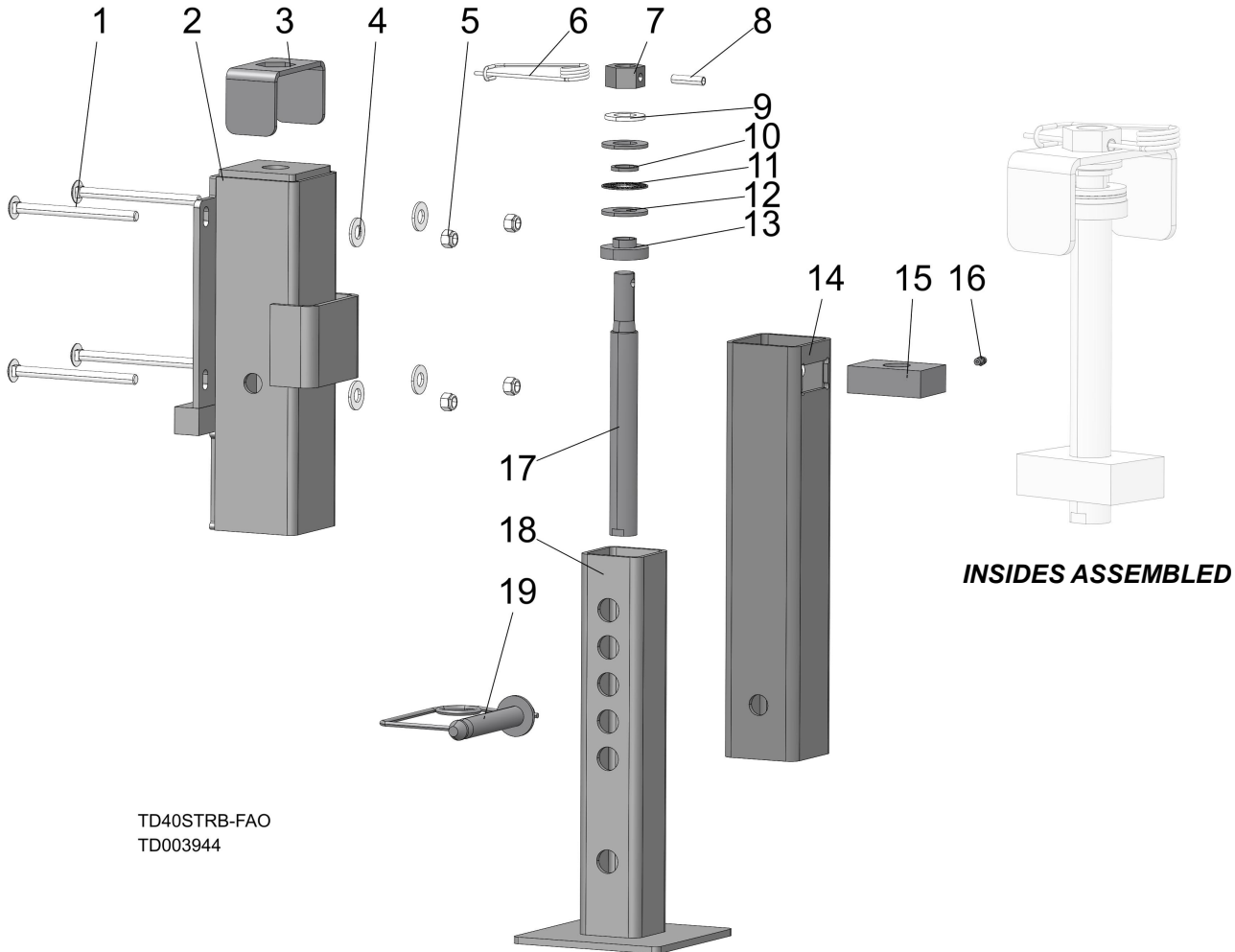

TD40STRB-FAO
TD003944

REF	PART #	DESCRIPTION	COMMENTS	QTY.
1	F05007-113	Bolt, 3/8-16x5 Carriage		4
2	003943	Wldmnt, Front Adj Outrigger Mount		1
3	059577	Bracket, Adjustable Outrigger Lock		1
4	F05011-2	Washer, 1/2 SAE Flat		4
5	F05010-10	Nut, 3/8-16 Hex Nyl Lock		4
6	F05012-162	Pin, Locking Wire 1/8dia x 2-13/16		1
7	056774	Nut, Adjustable Outrigger Hex		1
8	F05012-127	Pin, 5/16x1 1/4 Roll		1
9	F05011-62	Washer, 3/4 SAE Flat		1
10	039641	Seal, Outrigger Acme Screw		1
	039639	Assy, Adj. Outrigger Thrust Bearing		1
11	039637	Bearing, Needle-Roller Thrust		1
12	039638	Washer, Thrust Bearing		2
13	039645	Sleeve, Outrigger Screw		1
14	003981	Tube, 3x3x15 1/4 Outrigger Guide		1
15	039636	Nut, Adj. Outrigger Long Acme		1
16	P05060	Fitting, 1/4-28 Grease		1
17	039642	Screw, 1-5 ACME Adj. Outrigger Long		1
18	056783	Wldmnt, Adjustable Outrigger Base		1
19	056817	Pin, Adj Outrigger Locking		1

8.6 FAO Outrigger, Loading Side

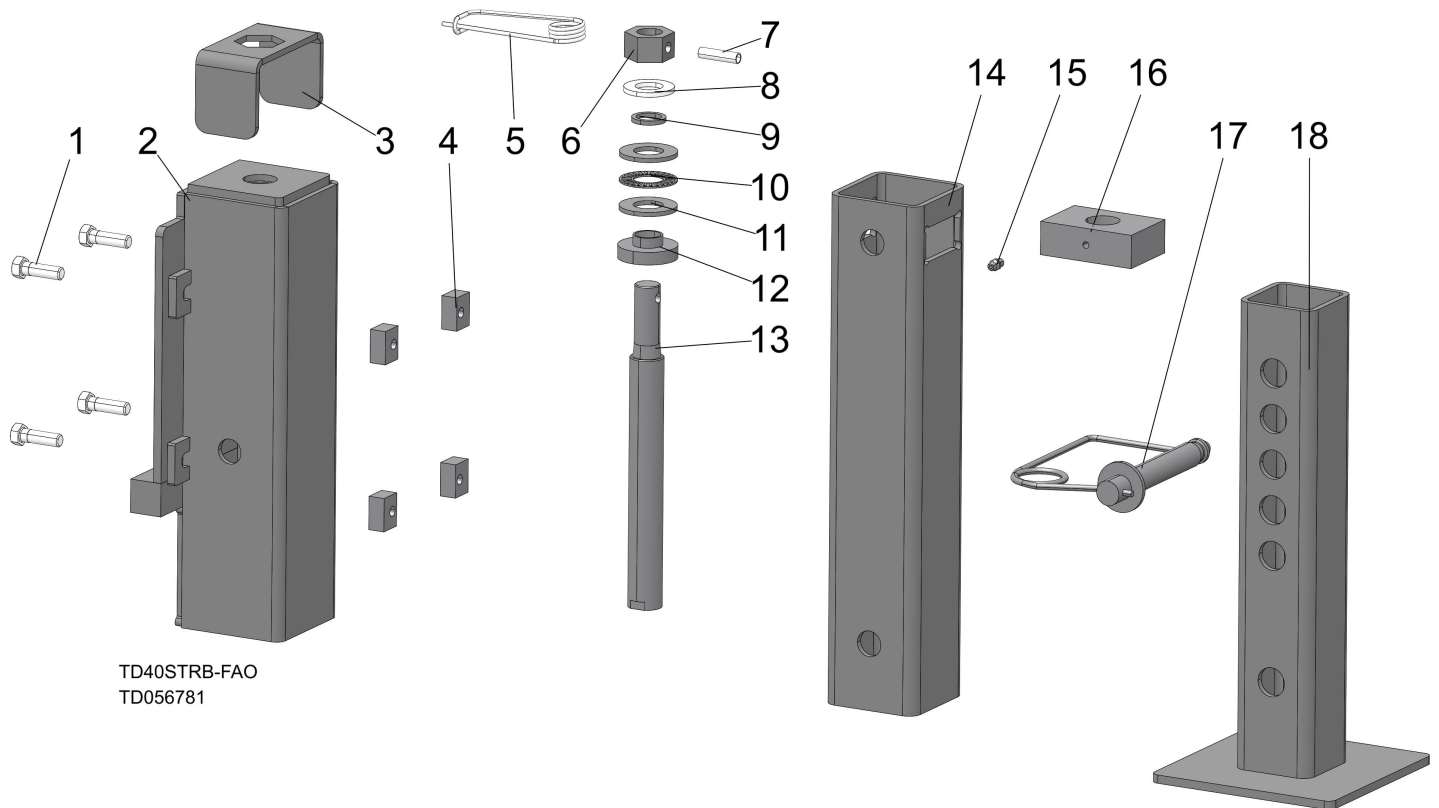

REF	PART #	DESCRIPTION	COMMENTS	QTY.
1	F05007-2	Bolt, 3/8-16x1 1/4 HH Gr2		4
2	056780	Wldmnt, Loading Side Adj Outrigger Mnt		1
3	059577	Bracket, Adjustable Outrigger Lock		1
4	056826	Nut, Loading Side Adj Outrigger Mnt		4
5	F05012-162	Pin, Locking Wire 1/8dia x 2-13/16		1
6	056774	Nut, Adjustable Outrigger Hex		1
7	F05012-127	Pin, 5/16x1 1/4 Roll		1
8	F05011-62	Washer, 3/4 SAE Flat		1
9	039641	Seal, Outrigger Acme Screw		1
	039639	Assy, Adj. Outrigger Thrust Bearing		1
10	039637	Bearing, Needle-Roller Thrust		1
11	039638	Washer, Thrust Bearing		2
12	039645	Sleeve, Outrigger Screw		1
13	039642	Screw, 1-5 ACME Adj. Outrigger Long		1
14	003981	Tube, 3x3x15 1/4 Outrigger Guide		1
15	P05060	Fitting, 1/4-28 Grease		1
16	039636	Nut, Adj. Outrigger Long Acme		1
17	056817	Pin, Adj Outrigger Locking		1
18	056783	Wldmnt, Adjustable Outrigger Base		1

8.7 FAO Outrigger, Offset Leg

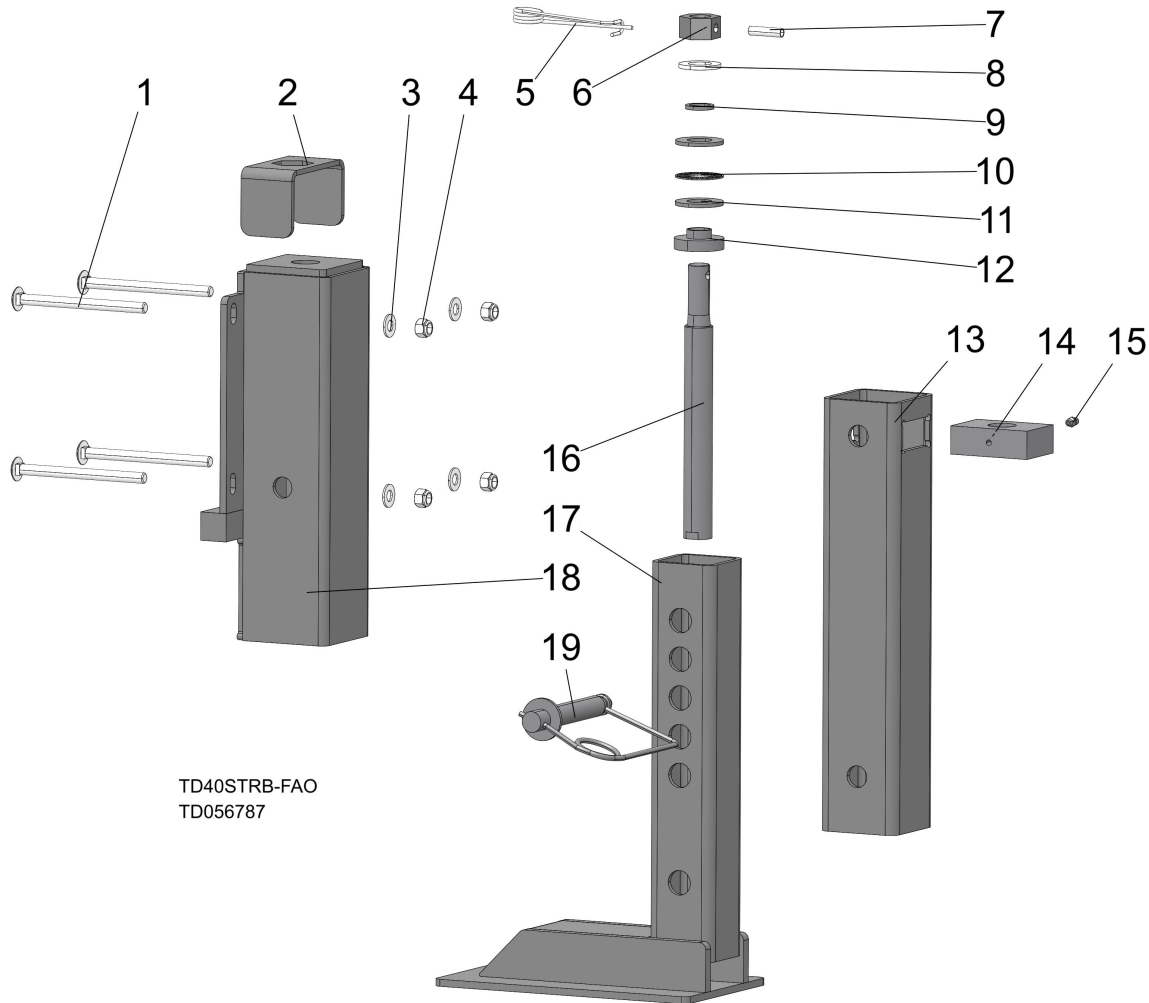

TD40STRB-FAO
TD056787

REF	PART #	DESCRIPTION	COMMENTS	QTY.
1	F05007-113	Bolt, 3/8-16x5 Carriage		4
2	003943	Wldmnt, Front Adj Outrigger Mount		1
3	059577	Bracket, Adjustable Outrigger Lock		1
4	F05011-2	Washer, 1/2 SAE Flat		4
5	F05010-10	Nut, 3/8-16 Hex Nyl Lock		4
6	F05012-162	Pin, Locking Wire 1/8dia x 2-13/16		1
7	056774	Nut, Adjustable Outrigger Hex		1
8	F05012-127	Pin, 5/16x1 1/4 Roll		1
9	039645	Sleeve, Outrigger Screw		1
10	F05011-62	Washer, 3/4 SAE Flat		1
11	039641	Seal, Outrigger Acme Screw		1
	039639	Assy, Adj. Outrigger Thrust Bearing		1
12	039637	Bearing, Needle-Roller Thrust		1
13	039638	Washer, Thrust Bearing		2
14	003981	Tube, 3x3x15 1/4 Outrigger Guide		1
15	039636	Nut, Adj. Outrigger Long Acme		1
16	P05060	Fitting, 1/4-28 Grease		1
17	039642	Screw, 1-5 ACME Adj. Outrigger Long		1
18	056783	Wldmnt, Adjustable Outrigger Base		1
19	056817	Pin, Adj Outrigger Locking		1

8.8 FAO Outrigger, Rear

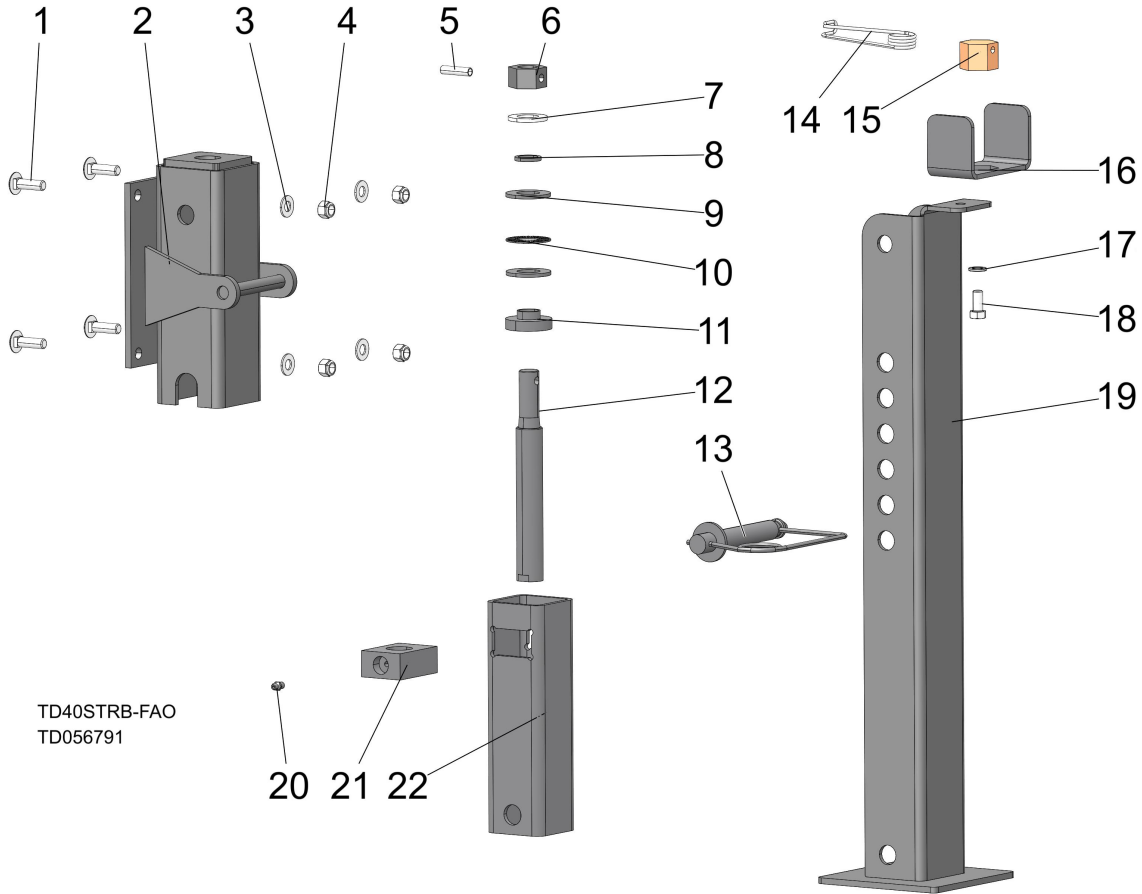

TD40STRB-FAO
TD056791

REF	PART #	DESCRIPTION	COMMENTS	QTY.
1	F05007-11	Bolt, 3/8-16x1 1/4 Carriage		4
2	056815	Wldmnt, Rear Adj Outrigger Mount		1
3	F05011-3	Washer, 3/8 Flat SAE		4
4	F05010-10	Nut, 3/8-16 Hex Nyl Lock		4
5	F05012-127	Pin, 5/16x1 1/4 Roll		1
6	056774	Nut, Adjustable Outrigger Hex		1
7	F05011-62	Washer, 3/4 SAE Flat		1
8	039641	Seal, Outrigger Acme Screw		1
	039639	Assy, Adj. Outrigger Thrust Bearing		1
9	039638	Washer, Thrust Bearing		2
10	039637	Bearing, Needle-Roller Thrust		1
11	039645	Sleeve, Outrigger Screw		1
12	056818	Screw, 1-5 ACME Adj. Outrigger Short		1
13	056817	Pin, Adj Outrigger Locking		1
14	F05012-162	Pin, Locking Wire 1/8dia x 2-13/16		1
15	110560	Nut, FAO Outrigger Lock		1
16	059577	Bracket, Adjustable Outrigger Lock		1
17	F05011-4	Washer, 3/8 Split Lock		1
18	F05007-118	Bolt, 3/8-16x3/4 HH Gr5		1
19	056816	Leg Wldmnt, Rear Outrigger Adj		1
20	P05060	Fitting, 1/4-28 Grease		1
21	056823	Nut, Adj Outrigger Short ACME		1
22	056795	Tube, Rear Adj Outrigger Guide		1

8.9 Board Return Table Assembly

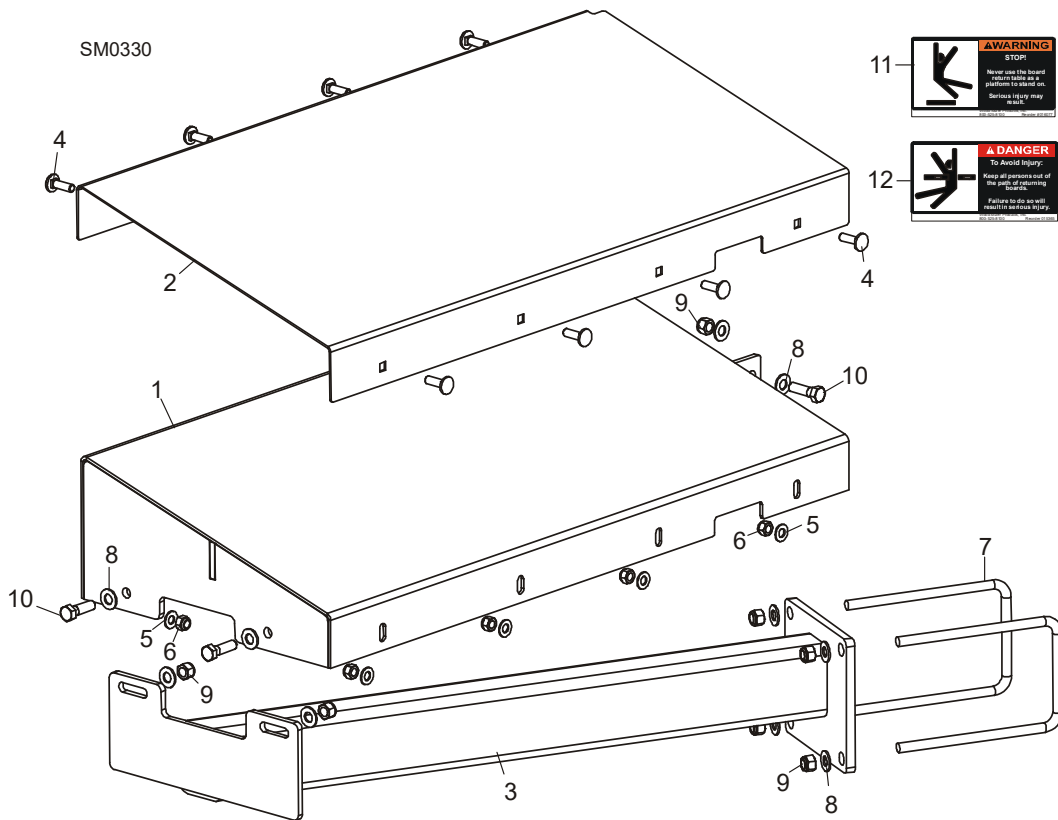

REF	PART #	DESCRIPTION	COMMENTS	QTY.
	003264	TABLE ASSEMBLY, BOARD RETURN		1
	003270	TABLE ASSEMBLY, BOARD RETURN ()		1
1	055515	Table Weldment, Board Return		1
2	003259	Cover, Board Return Table		1
3	055533	Mount Weldment, Board Return Table		1
	038992	Mount Weldment, Board Return Table ()		1
4	F05006-9	Bolt, 5/16-18 x 1" Carriage Head		8
5	F05011-17	Washer, 5/16" SAE Flat		8
6	F05010-58	Nut, 5/16-18 Nylon Lock		8
7	003207	Bolt, 3/8-16 x 4" x 5" 'U'		2
8	F05011-3	Washer, 3/8" SAE Flat		10
9	F05010-10	Nut, 3/8-16 Hex Nylon Lock		7
10	F05007-123	Bolt, 3/8-16 x 1 1/4" Hex Head Grade 5		3
11	016077	Decal, Board Return Table Warning		1
12	015365	Decal, Board Return Danger		1

8.10 Pivot Bed Rail Assembly

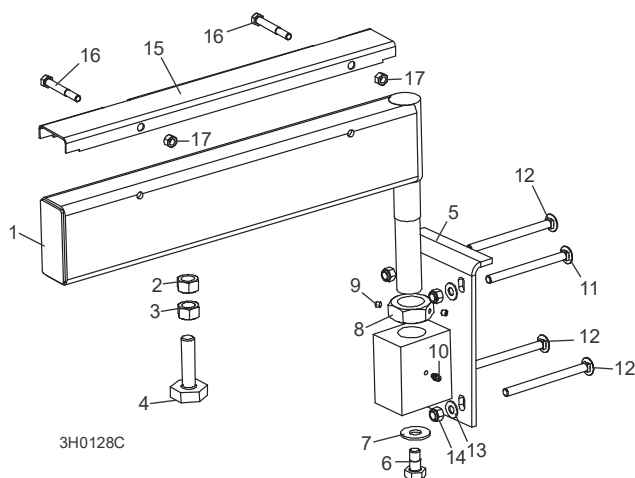

REF	PART #	DESCRIPTION	COMMENTS	QTY.
	A13015	PIVOT BED RAIL ASSEMBLY ()		
	012993	PIVOT BED RAIL ASSEMBLY ()		2
1	W13014	Pivot Bed Rail Weldment ()	Available in assemblies only.	1
	012992	Pivot Bed Rail Weldment ()	Available in assemblies only.	1
2	F05010-84	Nut, 5/8-11 Pilot Weld		2
3	F05010-5	Nut, 5/8-11 Hex		2
4	S13006	Bolt, Bed Rail Adjustment		2
5	W13090	Bracket, Pivot Rail Mounting		1
6	F05008-50	Bolt, 1/2-13 x 1" Hex Head Grade 2		1
7	F05011-52	Washer, 9/16" SAE Flat		1
8	S13016	Nut, Pivot Rail Adjustment		1
9	F05005-42	Screw, 1/4-28 x 1/4" Brass Tip Set		2
10	P04107	Fitting, 3/16" Grease		1
11	F05007-114	BOLT, 3/8-16 X 4 3/4" CARRIAGE HEAD		2
12	F05007-113	BOLT, 3/8-16 X 5" CARRIAGE HEAD		6
13	F05011-3	WASHER, 3/8" SAE FLAT		8
14	F05010-10	NUT, 3/8-16 NYLON LOCK		8
	017710	COVER KIT, PIVOT RAIL STAINLESS STEEL ()		2
	015926	COVER KIT, PIVOT RAIL STAINLESS STEEL ()		2
15	S13012	Cover, Stainless Steel Pivot Bed Rail ()		1
	012994	Cover, Stainless Steel Pivot Bed Rail ()		1
16	F05006-10	Bolt, 5/16-18 X 2 1/2" Hex Head		2
17	F05010-6	Nut, 5/16-18 Hex Lock		2
	015970	WRENCH, BED RAIL ADJUSTMENT	(See Section 8.1)	1

8.11 Safety Chain Assembly

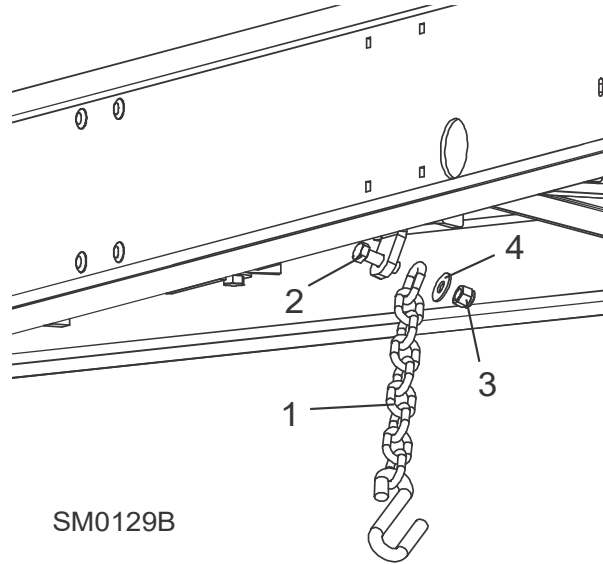

REF	PART #	DESCRIPTION	COMMENTS	QTY.
1	107972	CHAIN, 15 INCH SAFETY		1
2	F05008-33	BOLT, 1/2-13X1 1/2 HEX HEAD GRADE 5		1
3	F05010-8	NUT, 1/2-13 NYLON HEX LOCK		1
4	F05011-35	WASHER, 7/16 STANDARD FLAT		1

8.12 Saw Head Rest Pin Assembly

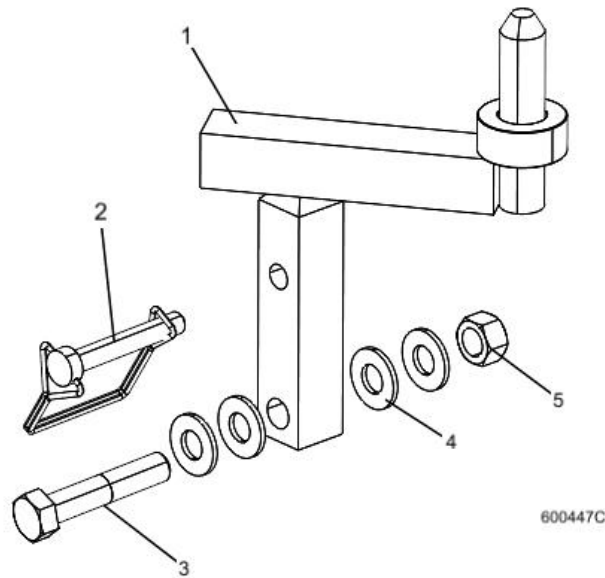

REF	PART #	DESCRIPTION	COMMENTS	QTY.
	079485	Pin Assy, Rest, 40/50		
	079511	Pin Assy, Rest, 40/50 Hyd Wide		
1	014102	Pin Weldment, C-Frame Rest 96 Hyd		1
	079510	Pin Wldmt, Rest, 40/50 Hyd Wide		1
2	014151	Pin, 3/8x2 1/4 Sq Wire Lock		1
3	F05008-74	Bolt, 1/2-13 x 2 1/2" Hex Head Grade 5	F05008-74 was F05008-10; two washers added after 5/14/2021, ECN 37840.	1
4	F05011-2	Washer, 1/2 SAE Flat		4
5	F05010-3	Nut, 1/2-13 Swaged Hex		1

8.13 Bed Frame Decals

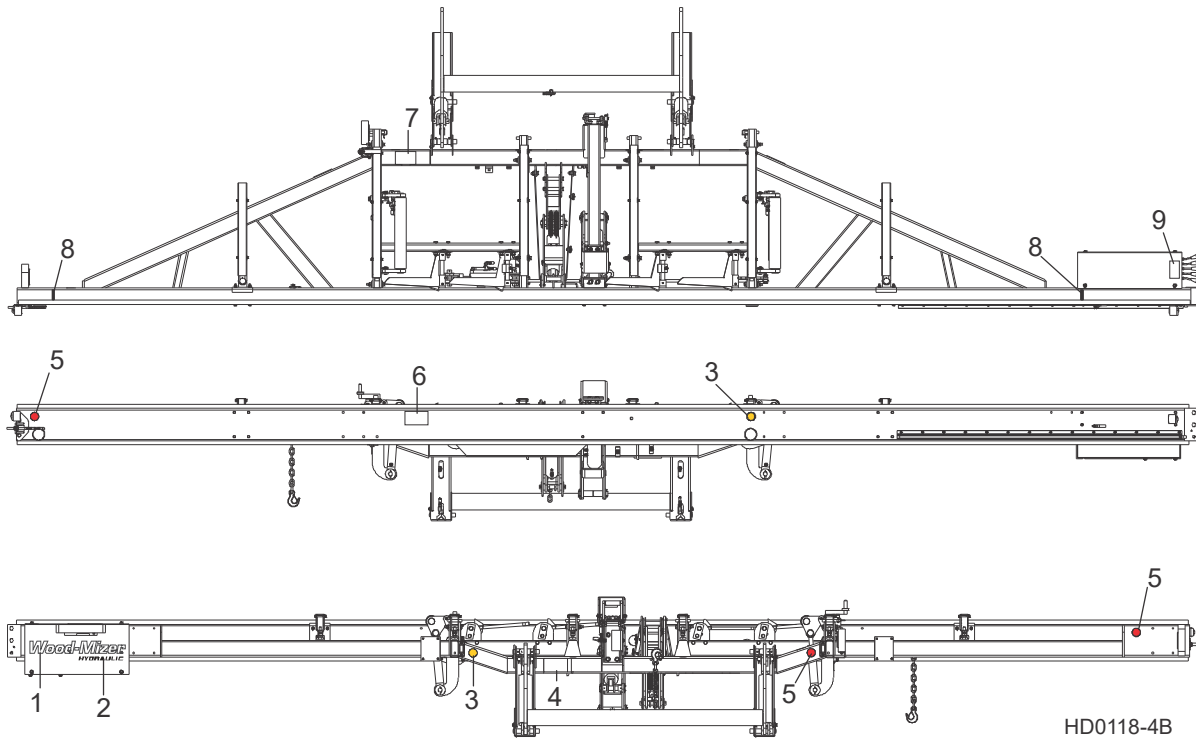

HD0118-4B

REF	PART #	DESCRIPTION	COMMENTS	QTY.
1	065034	DECAL, WHITE WOOD-MIZER EURO LOGO		1
2	065035	DECAL, HYDRAULIC EURO LOGO BLACK STD.		1
3	P07453	DECAL, AMBER REFLECTIVE 2" ROUND		2
4	S09851	DECAL, KEEP AWAY DANGER		1
5	P07452	DECAL, RED REFLECTIVE 2" ROUND		3
6	P10287	DECAL, PINCH POINT DANGER		1
7	S12581	DECAL, SAW HEAD REST CAUTION		1
8	S12051	DECAL, LOG LIMIT STRIPE		2
9	P12961	DECAL, KEEP AWAY HYDRAULIC WARNING		1

8.14 Board Outfeed Table (Optional)

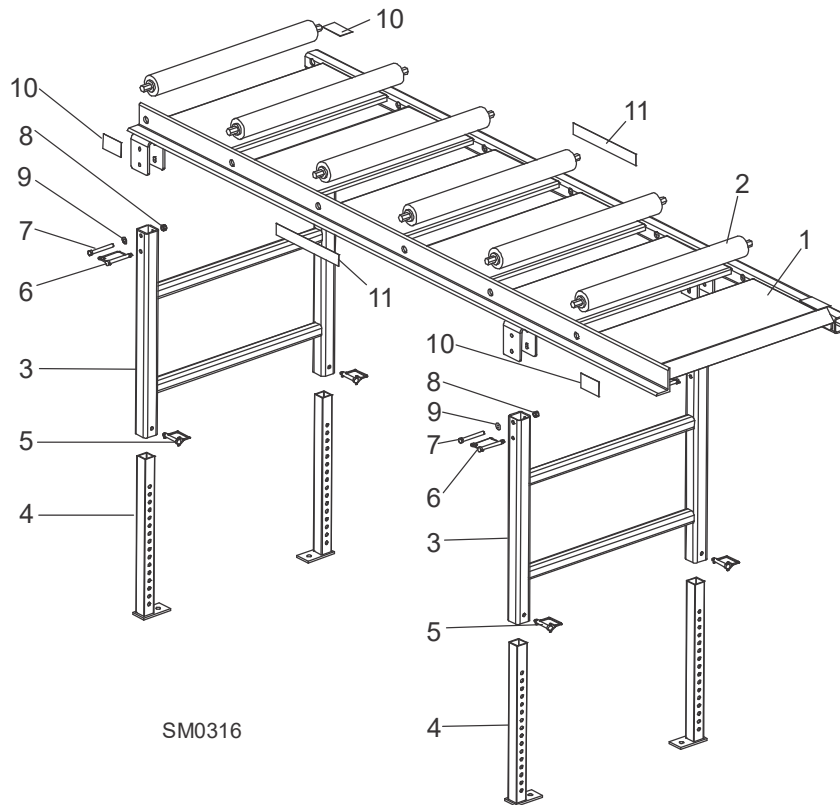

REF	PART #	DESCRIPTION	COMMENTS	QTY.
	016652	TABLE ASSEMBLY, BOARD OUTFEED		1
1	016606	Table Weldment, Board Outfeed		1
2	038167	Roller, 2 1/2" x 25"		6
3	016609	Mount Weldment, Outfeed Table Leg		2
4	016651	Leg Weldment, Outfeed Table		4
5	014151	Pin, 3/8" x 2 1/4" Square Wire Lock		4
6	016677	Pin, Snap - Coil Tension		4
7	F05004-123	Bolt, 3/8-16x3 1/2 HH Gr5		4
8	F05010-222	Nut, 3/8-16 Flanged Hex Nylock		4
9	F05011-3	Washer, 3/8 Flat SAE		4
10	S12641	Decal, Hand Pinch Point Warning		4
11	015882	Decal, Wood-Mizer Logo 10.25"		2

SECTION 9 BED HYDRAULIC SYSTEM

9.1 Hydraulic Hoses

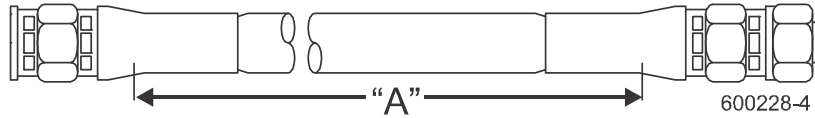

ID	Color Code	LENGTH "A"	Application (NOTE: See Hydraulic Information Section in Operator's Manual for Hydraulic Schematics)	PART #
H1	Purple	219"	1/4" Rear Toe Board Top	079000-219
H2	Black	219"	1/4" Rear Toe Board Base	079000-219
H3	Yellow	117"	1/4" Front Toe Board Top	079000-117
H4	Gray	117"	1/4" Front Toe Board Base	079000-117
H5	Green	204"	1/4" Clamp Up/Down Top	079000-204
H6	Yellow	193"	1/4" Clamp Up/Down Base	079000-194
H7	Red	178"	3/8" Loading Arm Base	079001-178
H8	Blue	178"	3/8" Loading Arm Top	079001-178
H9	Orange	65"	3/8" Side Support Base	079001-65
H10	Plain	73"	3/8" Side Support Top	079001-73
H11	Orange	177"	3/8" Clamp In/Out Base	079001-177
H12	White	151"	3/8" Clamp In/Out Top	079001-151
H13	Green	38"	3/8" Loading Arm Branch Top	079001-38
H14	Green	77"	3/8" Loading Arm Branch Top	079001-77
H15	Yellow	81"	3/8" Loading Arm Branch Base	079001-81
H16	Yellow	43"	3/8" Loading Arm Branch Base	079001-43
H17	Plain	181"	3/8" Log Turner Base	079001-181
H18	Pink	181"	3/8" Log Turner Top	079001-181
H19	Purple	177"	3/8" Log Turner Motor (Nearest Frame)	079001-177
H20	Black	180"	3/8" Log Turner Motor (Furthest from Frame)	079001-180
H21	Plain	15"	1/4" Pump To Valve (two hoses)	057964
H22	Plain	6 1/2"	3/8" Gauge To Valve	079001-6.5

9.2 Hydraulic Control Box

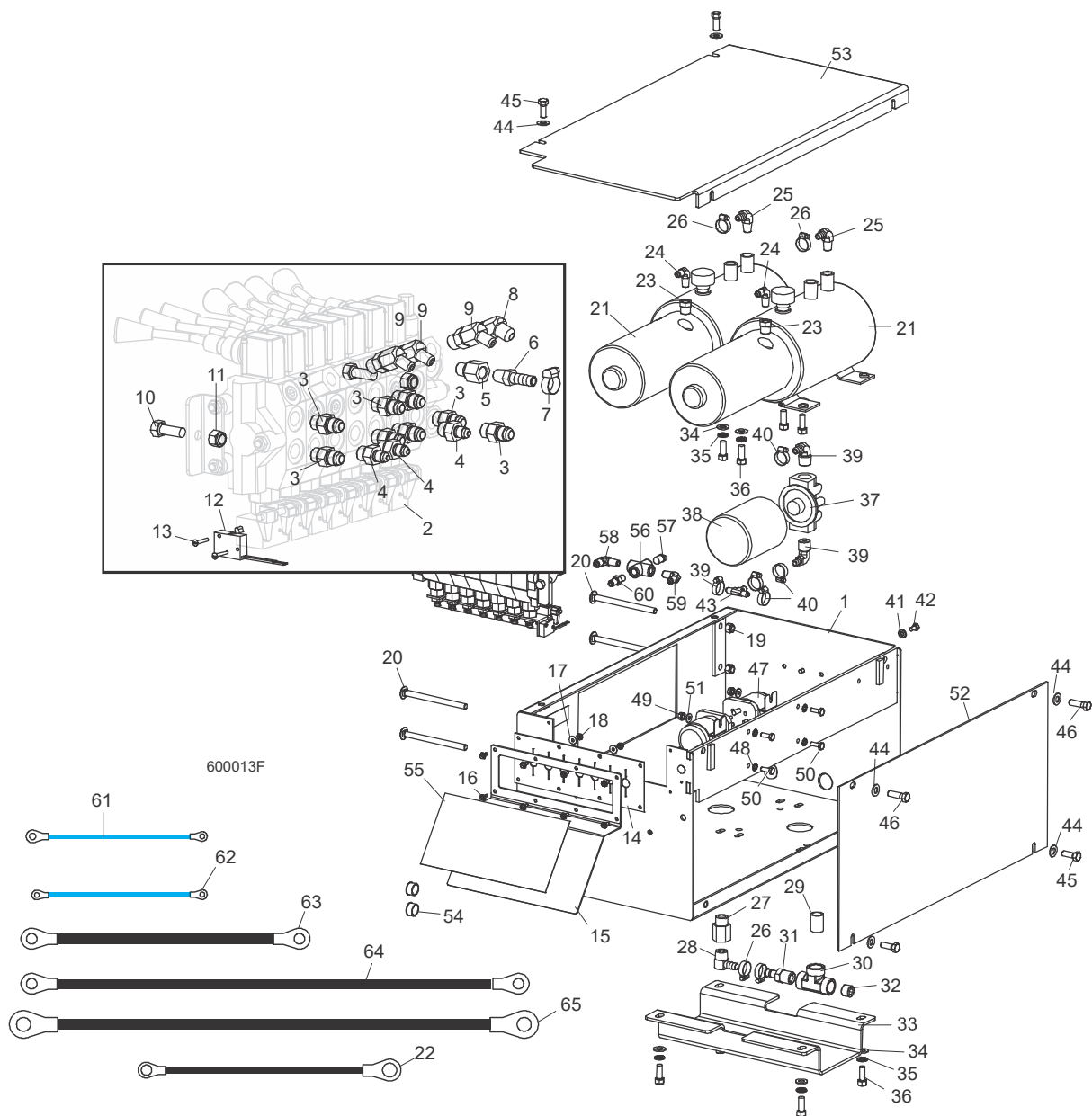

REF	PART #	DESCRIPTION	COMMENTS	QTY.
	017649	BOX ASSEMBLY, HYDRAULIC CONTROL		1
1	034383	Box Weldment, Hydraulic Control		1
	034533	Valve Assembly, 7-Section Hydraulic		1
2	034451	Valve, 7-Section Hydraulic		1
3	014687	Fitting, 3/8" O-Ring x 3/8" JIC		8
4	P26284	Fitting, 1/4" JIC x 3/8" O-Ring		3
5	014686	Fitting, #6 SAE x 1/4" NPT Female		1
6	014685	Fitting, 1/4" NPT x 3/8" Hose Barb		1
7	P12739	Clamp, 11/16" Hose		1
8	015489	Fitting, #6 SAE 45° Elbow		1
9	015488	Fitting, #4 SAE x #6 SAE 45° Elbow		3
10	F05007-7	Bolt, 3/8-16 x 1" Hex Head		2

REF	PART #	DESCRIPTION	COMMENTS	QTY.
11	F05010-10	Nut, 3/8-16 Hex Nylon Lock		2
12	024198	Switch, Hydraulic Valve Lever		1
13	F05004-13	Screw, #4-40 x 3/4" Slotted Head		2
14	034202	Seal, 7-Handle Valve Rubber		1
15	033999	Plate, 7-Handle Decal		1
16	F05015-7	Screw, #10-24 x 1/2" Self-Tapping		8
17	F05011-18	Washer, #10 SAE Flat		2
18	F05010-14	Nut, #10-24 Hex Self-Locking		2
19	F05010-10	Nut, 3/8-16 Hex Nylon Lock		4
20	F05007-113	Bolt, 3/8-16 x 5" Carriage Head		4
	034534	Pump Assembly, LT60/70 DC Hydraulic		1
21	061764	Pump Kit, Hydraulic w/Motor		2
	016199	Pump, Hydraulic Replacement Mon-arch Model #12070		1
	052807	Motor Kit, Hydraulic Replacement		1
	038683	Motor, 12 VDC Hydraulic Pump #08714 (Iskra)	Available in assemblies only.	1
	038682	Brush Kit, 4-Valve Hydraulic Pump Motor #08658-I (Iskra)		1
	P12513	Bearing, Base Motor #02318		1
22	052806	Wire Assembly, Motor Brush Ground		1
	P12817	Cap, Hydraulic Pump Vented Fill #03171		1
	P10198	O-Ring, Hydraulic Pump/Reservoir #02352		1
	P10315	Seal, Hydraulic Pump/Motor #02330		1
23	015490	Fitting, 3/8" NPT x 1/4" NPT Reducer		2
24	P09142	Fitting, 1/4" NPT x 1/4" JIC Elbow		2
25	P12708	Fitting, 3/8" NPT x 3/8" Hose Barb Elbow		2
26	P12739	Clamp, 11/16" Hose		4
27	015995	Fitting, 1/2" NPT x 1/2" NPT Adapter		1
28	015997	Fitting, 1/2" NPT x 1/2" Hose Barb Elbow		1
29	016795	Fitting, 1/2" NPT Close Brass Nipple		1
30	016793	Fitting, 1/2" NPT Female Tee		1
31	016794	Fitting, 1/2" NPT Male x 1/2" Hose Barb		1
32	P26258	Fitting, 1/2" NPT Pipe Plug		1
33	015992	Guard, Crossover Hose		1
34	F05011-3	Washer, 3/8" SAE Flat		8
35	F05011-4	Washer, 3/8" Split Lock		8
36	F05007-7	Bolt, 3/8-16 x 1" Hex Head		8
37	P22683	Manifold, Hydraulic Filter w/Cartridge		1
38	P20301	Filter, S28 Hydraulic Cartridge		1
39	P12707	Fitting, 1/2" NPT x 3/8" Hose Barb Elbow		2
40	P12739	Clamp, 11/16" Hose Clamp		2
41	F05011-14	Washer, 1/4" Split Lock		2
42	F05005-15	Bolt, 1/4-20 x 1/2" Hex Head		2
43	015485	Fitting, 3/8" Hose Barb Tee		1
44	F05011-3	Washer, 3/8" SAE Flat		6

REF	PART #	DESCRIPTION	COMMENTS	QTY.
45	F05007-87	Bolt, 3/8-16 x 1" Hex Head Grade 5		4
46	F05007-2	Bolt, 3/8-16 x 1 1/4" Hex Head		2
47	016371	Solenoid Kit, 200A 12V SPST Hydraulic Motor		2
	015470	Solenoid, 200A 12V SPST Cont. Duty	Available in assemblies only.	1
	015426	Diode Assembly, Solenoid Coil Chassis Gnd		1
48	F05011-37	Washer, 1/4" External Lock		4
49	F05010-9	Nut, 1/4-20 Hex Self-Locking		4
50	F05005-1	Bolt, 1/4-20 x 3/4" Hex Head Full Thread		4
51	F05011-11	Washer, 1/4" SAE Flat		4
52	015227	Plate, Hydraulic Control Box Side		1
53	015228	Plate, Hydraulic Control Box Top		1
54	P04137	Grommet, 5/8" Wire		2
55	017669	Decal, Hydraulic Control Lever		1
56	P22311	Fitting, 1/4" NPT Cross		1
57	P05498	Plug, 1/4" NPT Pipe		1
58	015491	Fitting, 3/8" JIC x 1/4" NPT Elbow		1
59	P09142	Fitting, 1/4" NPT x 1/4" JIC Male Elbow		1
60	P09143	Fitting, 1/4" NPT x 1/4" JIC Male		1
	036303	Hose, 3/8" x 6 1/2" Hydraulic w/Fittings		1
	036292	Hose, 1/4" x 15" Hydraulic w/Fittings		2
61	036315	WIRE ASSEMBLY, 14 GA X 4" #10 & 5/16" RING TERMINALS		
62	036314	WIRE ASSEMBLY, 14 GA X 4" #10 RING TERMINALS		1
63	036311	CABLE ASSEMBLY, 1 GA X 6" HYDRAULIC PUMP TO SOLENOID		1
64	036310	CABLE ASSEMBLY, 1 GA X 16" HYDRAULIC PUMP TO SOLENOID		1
65	036312	CABLE ASSEMBLY, 1 GA X 16" HYDRAULIC PUMP GROUND		2
	F05011-36	WASHER, 3/8" STAR EXTERNAL		3

9.3 Hydraulic Power Supply Strip

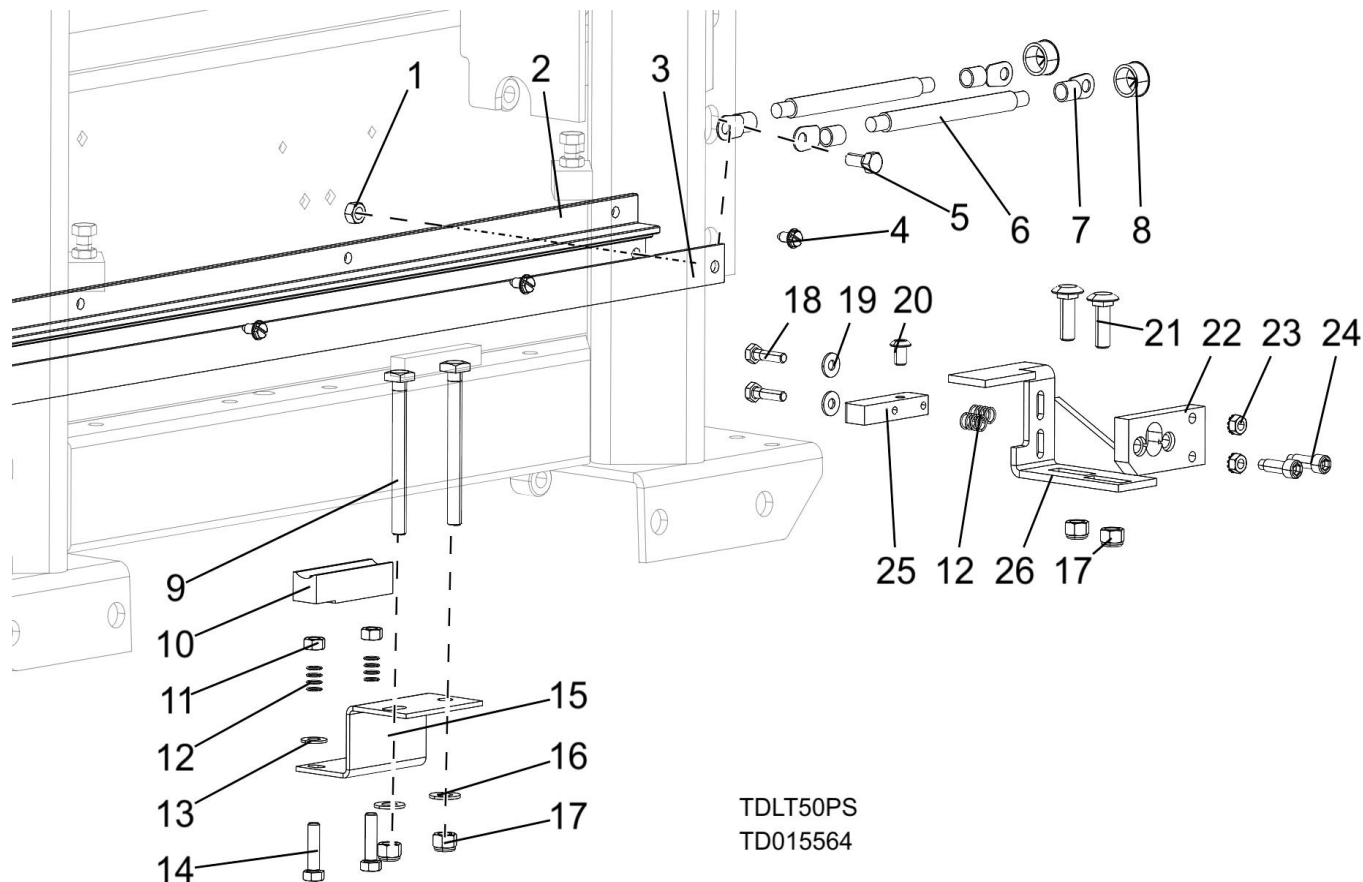

TDLT50PS
TD015564

REF	PART #	DESCRIPTION	COMMENTS	QTY.
	015564	STRIP ASSEMBLY, SUPER CONTACT		1
1	F05010-86	Nut, 5/16-18 Nyl Lock Hex		1
2	P11976	Housing, Contact Strip		1
3	S10075	Strip, 1/8x1x69 13/16 CU		1
4	F05015-1	Bolt, 1/4-20x1/2 SI HH		8
5	F05006-45	Bolt, 5/16-18x3/4 HH Moulded Blk		1
	052161	Cable Assembly, 1AWG		2
6	R01971	Cable, 1AWG SO Welding, Black		1
7	F05092-16	Terminal, 5/16 1-2Ga Ring NI Loose		2
8	P04137	Grommet, 5/8 Wire		2
	R01950-8	Tubing, 3/4 Heat Shrink W/Adhesive ID	Not Shown	.33ft
	016797	GROUND ASSY, FLOATING CONTACT		1
9	F05007-175	Bolt, 3/8-16x4 Square Head		2
10	015264	Block, Exten. Hyd Ground Contact		1
11	F05010-17	Nut, 5/16-18 Hex		2
12	P10077	Spring, .42x.59x.042 Comp		4
13	F05011-17	Washer, 5/16 SAE Flat		2

9 **Bed Hydraulic System**
Hydraulic Power Supply Strip

REF	PART #	DESCRIPTION	COMMENTS	QTY.
14	F05006-93	Bolt, 5/16-18x1-1/4 HH FT Gr5		2
15	016792	Plate, HPS Ground Contact Mount		1
16	F05011-3	Washer, 3/8 Flat SAE		2
17	F05010-10	Nut, 3/8-16 Hex Nyl Lock		4
	017671	CONTACT ASSY, POSITIVE HYD POWER (97+)		1
18	F05005-38	Screw, 1/4-20x1 HHC		2
19	F05011-11	Washer, 1/4 SAE Flat		2
20	F05006-20	Screw, 5/16-18x1/2 SBH		1
21	F05007-11	Bolt, 3/8-16x1 1/4 Carriage		2
22	S10072	Plate, 1/2 Nyl Insulator Contact		1
23	F05010-9	Nut, 1/4-20 Keps		2
24	F05006-143	Bolt, 5/16x3/4 Shoulder (1/4-20 Thread)		2
25	015253	Button, Hot Contact 1997		1
26	015324	Plate Wdmt, Hot Contact		1
27	015564	Strip Assy, Super Contact		1

9.4 Hydraulic Log Loader

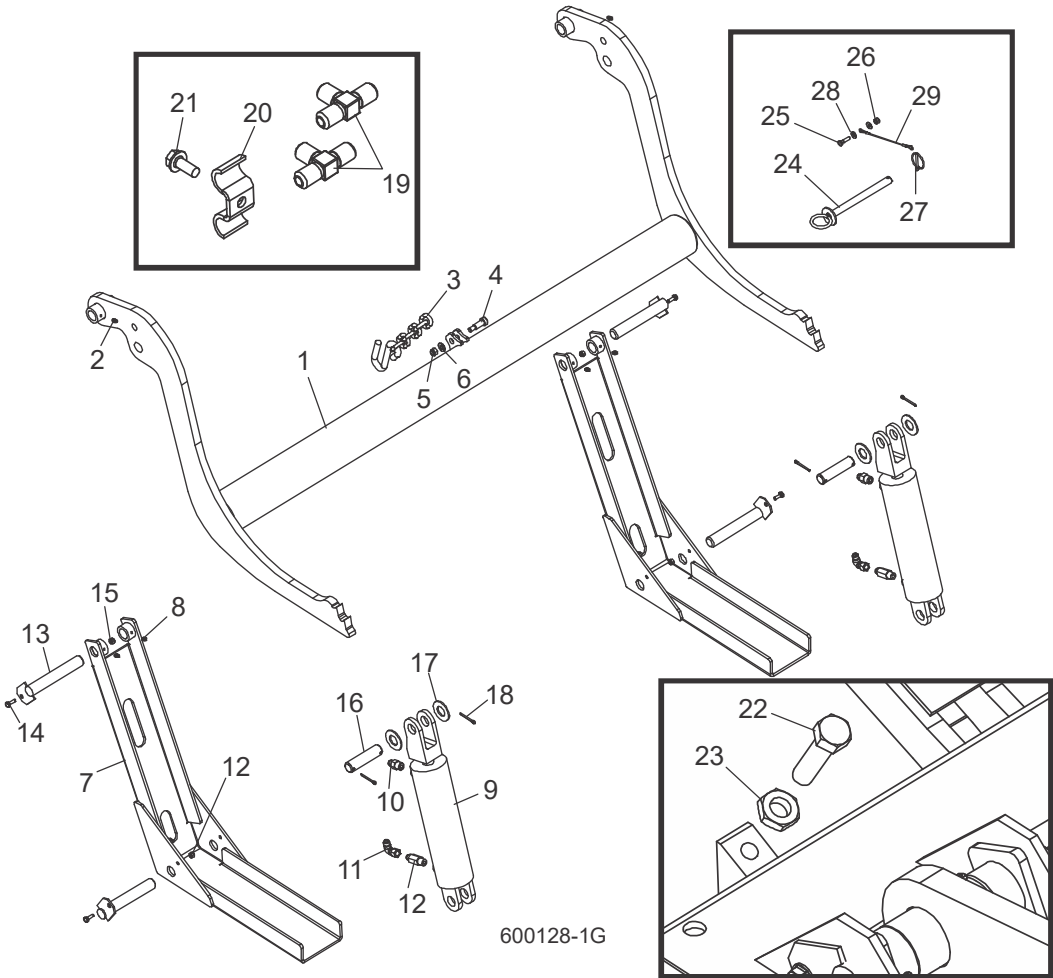

600128-1G

REF	PART #	DESCRIPTION	COMMENTS	QTY.
	034539	LOADER ASSEMBLY, HYDRAULIC LOG		1
	036416	Arm Assembly, Hydraulic Log Loading		1
1	110372	Arm Weldment, Log Loading		1
2	P04107	Fitting, 3/16" Grease		2
3	110472	Chain, 12-1/2 Inch Safety		1
4	F05008-146	Bolt, 1/2 x 1 Shoulder Socket		1
5	F05010-10	Nut, 3/8-16 Hex Nyloc		1
6	F05011-3	Washer, 3/8 Flat SAE		1
7	W09444	Channel, Hydraulic Log Loading Foot		2
8	P04107	Fitting, 3/16" Grease		4
	038735	Cylinder Assembly, Hydraulic Log Loader		2
9	042754	Cylinder, 8" X 3" Hydraulic (3/8" NPT Ports)		1
	P12956	Seal Kit, 8" x 3" Hydraulic Cylinder		1
10	016819	Fitting, 3/8" NPT x 3/8" JIC Male Connector		1
11	042756	Fitting, 3/8" JIC 90° Swivel Elbow		1
12	038734	Fitting, 3/8NPT 6.5GPM Velocity Fuse		1
13	W09446	Pin, Loading Arm Mount		4
14	F05005-1	Bolt, 1/4-20 x 3/4" Hex Head Full Thread		4

9 **Bed Hydraulic System**
Hydraulic Log Loader

REF	PART #	DESCRIPTION	COMMENTS	QTY.
15	F05010-69	Nut, 1/4-20 Hex Lock		4
16	S09251	Pin, Loading Arm Cylinder Mount		2
17	F05011-28	Washer, 1" SAE Flat		4
18	F05012-23	Pin, 3/16" X 1 1/2" Cotter		4
19	015487	Fitting, 3/8" JIC Union 'T'		1
20	016041	Clamp, 3/8" Hydraulic Hose		6
21	F05006-102	Bolt, 5/16-18 X 3/4" Hex Head Grade 5		6
22	F05008-7	BOLT, 1/2-13 X 3" HEX HEAD FULL THREAD GRADE 5		2
23	F05010-31	NUT, 1/2-13 JAM		2
	074208	ARM LOCK ASSEMBLY, LT70 WIDE LOADING (LT70 WIDE HEAD ONLY)		1
24	036692	Pin Weldment, Arm Support		1
25	F05005-101	Bolt, 1/4-20 x 1" Hex Head Grade 5		1
26	F05010-69	Nut, 1/4-20 Nylock		1
27	017604	Pin, Lynch 3/16" w/Chain		1
28	F05011-11	Washer, 1/4" SAE Flat		2
29	016090	Cable, 3/32" Dia. Board Return		1
	074207	LINK, 1/2" THEADED CHAIN QUICK (LT70 WIDE HEAD ONLY)		1

9.5 Hydraulic Log Turner

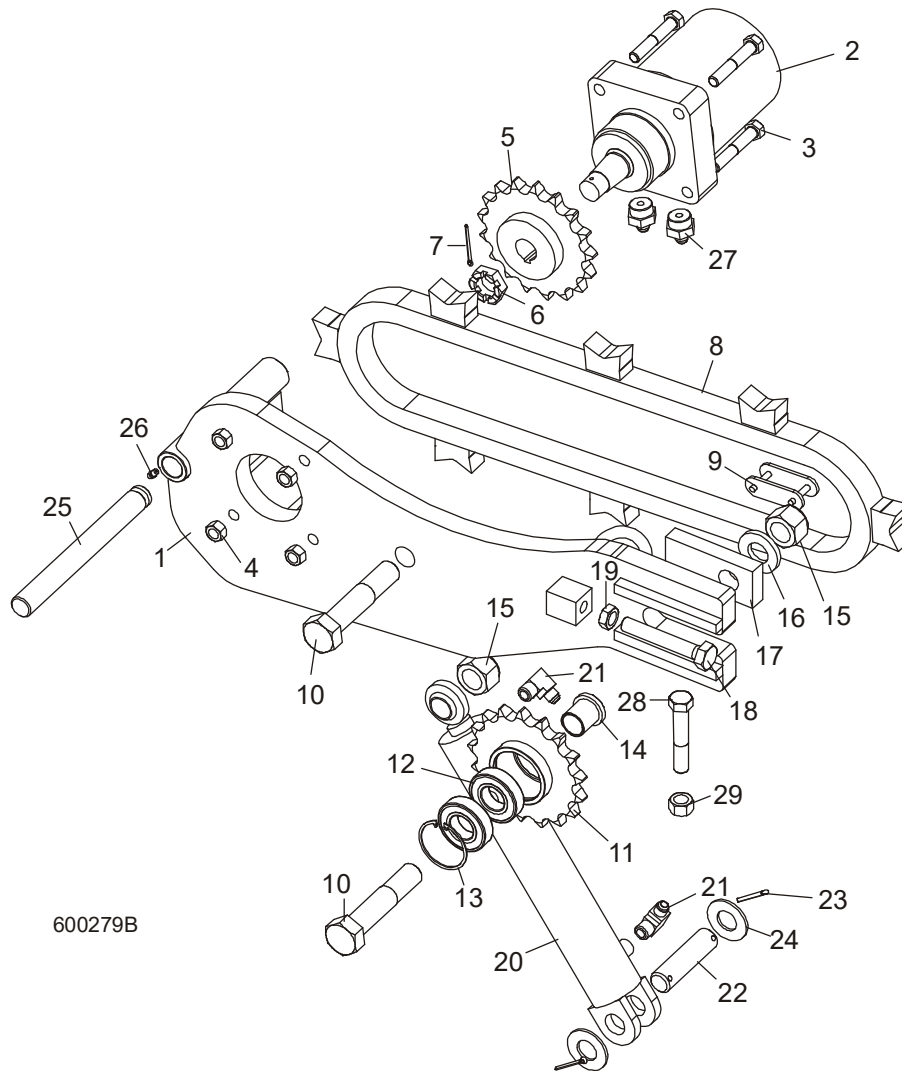

600279B

REF	PART #	DESCRIPTION	COMMENTS	QTY.
	006095	ARM ASSEMBLY, HYDRAULIC LOG TURNER		1
1	006471	Arm Weldment, Hydraulic Log Turner		1
2	007331	Motor, Hydraulic Log Turner		1
	061427	Kit, Seal Rebuild		1
3	F05008-23	Bolt, 1/2-13 x 3" Hex Head Grade 5		4
4	F05010-3	Nut, 1/2-13 Hex Lock		4
5	042192	Sprocket Weldment, Log Turner Drive		1
6	018741-2	Nut, Hydraulic Motor Castle		1
7	F05012-43	Pin, 1/8" x 1 3/4" Cotter		1
8	006097	Chain Weldment, Log Turner		1
9	016796	Link, #2080H Master		1
10	F05004-132	Bolt, 1-8 x 5" Hex Head Grade 8		2
	042193	Sprocket Assembly, Idler		1
11	042191	Sprocket Weldment, Idler		1
12	P11035	Bearing, 6206 25 Idler		2
13	F04254-12	Ring, 62mm #472 DIN Inside Retaining		1

9 **Bed Hydraulic System**
Hydraulic Log Turner

REF	PART #	DESCRIPTION	COMMENTS	QTY.
14	042187	Spacer, Idler Sprocket		2
15	F05010-109	Nut, 1-8 Hex Lock		2
16	038749	Washer, 1" ID x 2" OD x 1/4"		1
17	042188	Plate, Log Turner Chain Tensioner		1
18	F05009-31	Bolt, 5/8-11 x 4" Hex Head Full Thread Grade 5		1
19	F05010-82	Nut, 5/8-11 Hex Jam		1
20	128113	Cylinder, 2" x 10" Welded Rod End Hydraulic	128113 replaced 034267 per ECN 37500 on 6/24/2020. Cylinder may have a vendor # of either 322009 or 322896. The 322009 uses seal kit # 061364; 322896 uses seal kit # 128258.	1
21	016820	Fitting, 3/8" NPT x 3/8" JIC 90° Elbow		2
22	S09251	Pin, 1" x 3.88"		1
23	F05012-23	Pin, 3/16" x 1 1/2" Cotter		2
24	F05011-28	Washer, 1" SAE Flat		2
25	006722	Rod, Grooved Turner Mount		1
26	P05060	Fitting, 1/4-28 Grease		1
27	017640	Fitting, #10 SAE x 3/8" JIC Straight		2
28	F05009-16	BOLT, 5/8-18 X 3 1/2" HEX HEAD BOLT FULL THREAD		1
29	F05010-50	NUT, 5/8-18 HEX		1

9.6 Hydraulic Log Side Supports (Front)

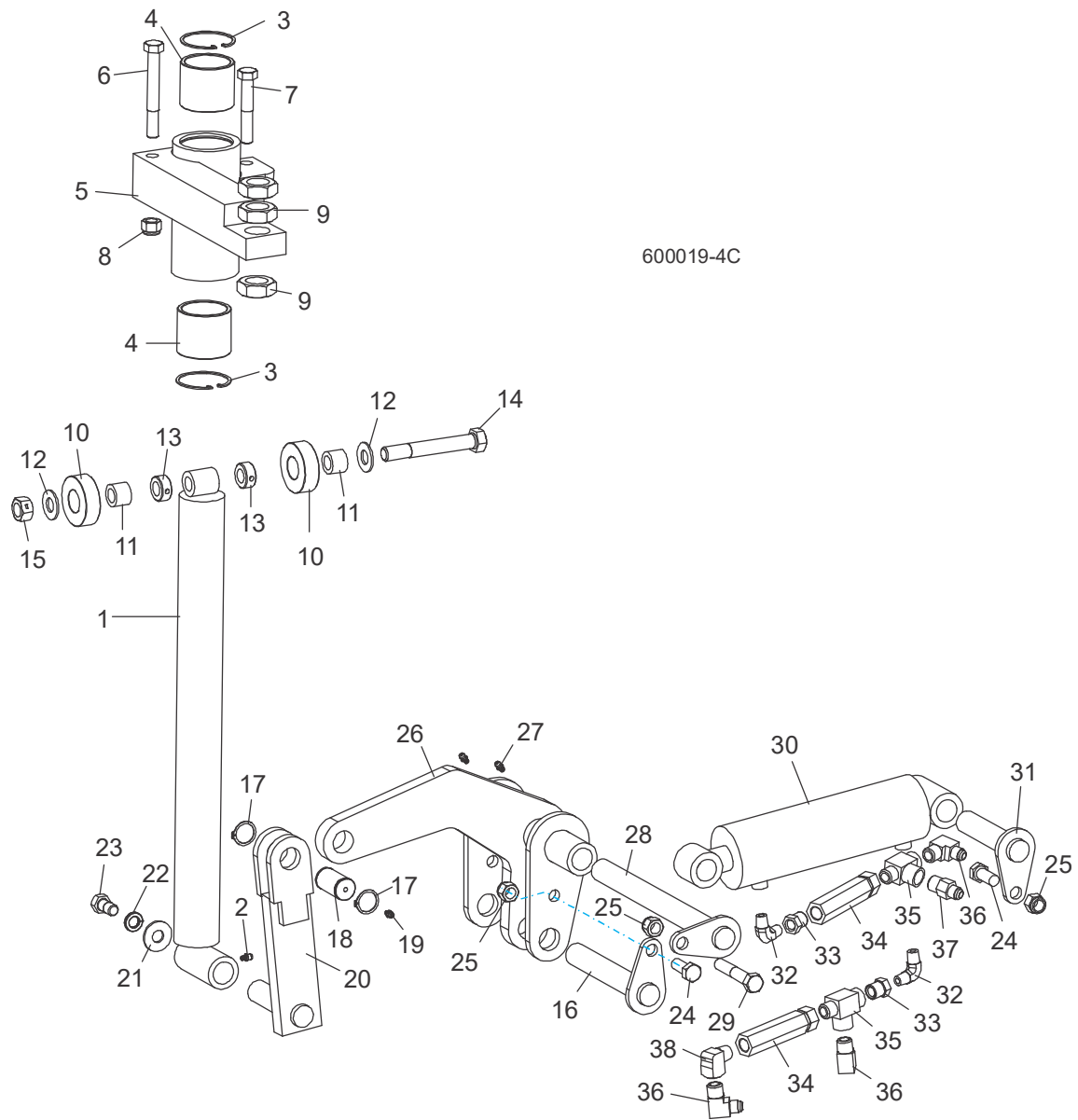

REF	PART #	DESCRIPTION	COMMENTS	QTY.
	034732	SUPPORT ASSEMBLY, VERTICAL HYDRAULIC SIDE		1
1	034704	Rod Weldment, Vertical Side Support		1
2	P04107	Fitting, 3/16" Straight Grease		1
3	F04254-12	Ring, 62mm Din #472 Inside Retaining		2
4	042262	Bushing, Side Support		2
5	034703	Mount Weldment, Vertical Side Support		1
6	F05008-78	Bolt, 1/2-13 x 4" Hex Head Grade 5		1
7	F05008-23	Bolt, 1/2-13 x 3" Hex Head Grade 5		1
8	F05010-8	Nut, 1/2-13 Hex Nylon Lock		2
9	F05010-118	Nut, 1-14 Hex Jam		3
	034733	Roller Kit, Side Support		1
10	016561	Roller, Side Support		2
11	016560	Bushing, 5/8" x 1" x 3/4" Bronze		2

9 **Bed Hydraulic System**
Hydraulic Log Side Supports (Front)

REF	PART #	DESCRIPTION	COMMENTS	QTY.
12	F05011-5	Washer, 5/8" SAE Flat		2
13	P05035	Collar, 5/8" Lock		2
14	F05009-10	Bolt, 5/8-11 x 4 1/2" Hex Head Grade 5		1
15	F05010-4	Nut, 5/8-11 Hex Lock		1
16	106880	PIN WELDMENT, 6-5/16" PIVOT		1
	036053	Pin Assembly, Side Support Pivot		1
17	F04254-15	Ring, 1" 3100-100 Outside Retaining		2
18	034718	Pin, Grooved Pivot	Available in assemblies only.	1
19	P04107	Fitting, 3/16" Straight Grease		1
20	034711	PUSHER WELDMENT, LOWER SIDE SUPPORT		1
21	F05011-52	WASHER, 9/16" SAE FLAT		1
22	F05011-9	WASHER, 1/2" SPLIT LOCK		1
23	F05008-50	BOLT, 1/2-13 X 1" HEX HEAD		1
24	F05008-37	BOLT, 1/2"-13 X 1 1/4" HEX HEAD GRADE 5		2
25	F05010-8	NUT, 1/2-13 HEX NYLON LOCK		3
26	106868	ARM WELDMENT, SIDE SUPPORT FRONT LIFT		1
27	P04107	FITTING, 3/16" STRAIGHT GREASE		2
28	034728	PIN WELDMENT, 10 7/8" PIVOT		1
29	F05008-23	BOLT, 1/2-13 X 3" HEX HEAD GRADE 5		1
30	034736	CYLINDER, 2 1/2" X 6" X 1/4" NPT PORT HYDRAULIC		1
31	034726	PIN WELDMENT, 4 3/8" PIVOT		1
32	P09140	Fitting, 1/4" NPT Male Pipe Elbow		2
33	015490	Fitting, 3/8" NPT x 1/4" NPT Reducer		2
34	015484	valve, Side Support Sequence		2
35	016822	Fitting, 3/8" NPT Male Run Tee		2
36	016820	Fitting, 3/8" NpT x 3/8" JIC Elbow		3
37	016819	Fitting, 3/8" NPT x 3/8" JIC Connector		1
38	P05759	Fitting, 3/8" NPT Street Elbow		1

9.7 Hydraulic Log Side Supports (Rear)

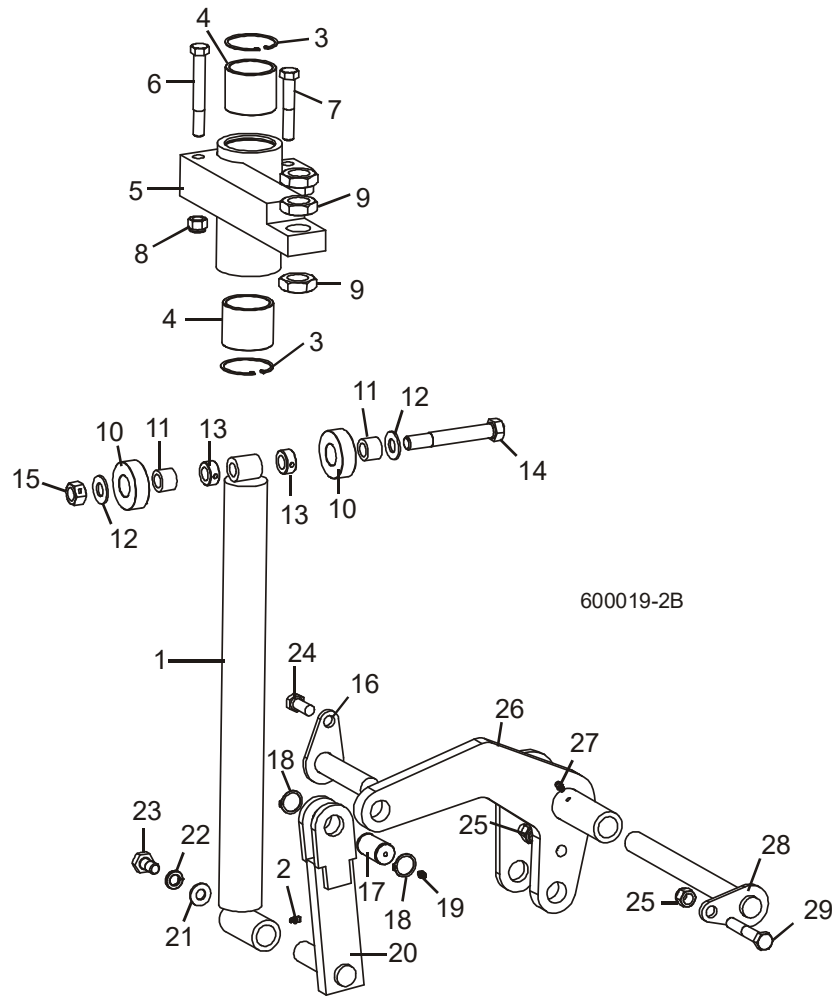

REF	PART #	DESCRIPTION	COMMENTS	QTY.
	034732	SUPPORT ASSEMBLY, VERTICAL HYDRAULIC SIDE		1
1	034704	Rod Weldment, Vertical Side Support		1
2	P04107	Fitting, 3/16" Straight Grease		1
3	F04254-12	Ring, 62mm Din #472 Inside Retaining		2
4	042262	Bushing, Side Support		2
5	034703	Mount Weldment, Vertical Side Support		1
6	F05008-78	Bolt, 1/2-13 x 4" Hex Head Grade 5		1
7	F05008-23	Bolt, 1/2-13 x 3" Hex Head Grade 5		1
8	F05010-8	Nut, 1/2-13 Hex Nylon Lock		2
9	F05010-118	Nut, 1-14 Hex Jam		3
	034733	Roller Kit, Side Support		1
10	016561	Roller, Side Support		2
11	016560	Bushing, 5/8" x 1" x 3/4" Bronze		2
12	F05011-5	Washer, 5/8" SAE Flat		2
13	P05035	Collar, 5/8" Lock		2
14	F05009-10	Bolt, 5/8-11 x 4 1/2" Hex Head Grade 5		1
15	F05010-4	Nut, 5/8-11 Hex Lock		1
16	034726	PIN WELDMENT, 4 3/8" PIVOT		1

9 **Bed Hydraulic System**
Hydraulic Log Side Supports (Rear)

REF	PART #	DESCRIPTION	COMMENTS	QTY.
	036053	PIN ASSEMBLY, SIDE SUPPORT PIVOT		1
17	034718	Pin, Grooved Pivot	Available in assemblies only.	1
18	F04254-15	Ring, 1" 3100-100 Outside Retaining		2
19	P04107	Fitting, 3/16" Straight Grease		1
20	034711	PUSHER WELDMENT, LOWER SIDE SUPPORT		1
21	F05011-52	WASHER, 9/16" SAE FLAT		1
22	F05011-9	WASHER, 1/2" SPLIT LOCK		1
23	F05008-50	BOLT, 1/2-13 X 1" HEX HEAD		1
24	F05008-37	BOLT, 1/2"-13 X 1 1/4" HEX HEAD GRADE 5		2
25	F05010-8	NUT, 1/2-13 HEX NYLON LOCK		2
26	034716	ARM WELDMENT, VERTICAL SIDE SUPPORT REAR LIFT		1
27	P04107	FITTING, 3/16" STRAIGHT GREASE		1
28	034728	PIN WELDMENT, 10 7/8" PIVOT		1
29	F05008-23	BOLT, 1/2-13 X 3" HEX HEAD GRADE 5		1

9.8 Hydraulic Log Side Supports (Link)

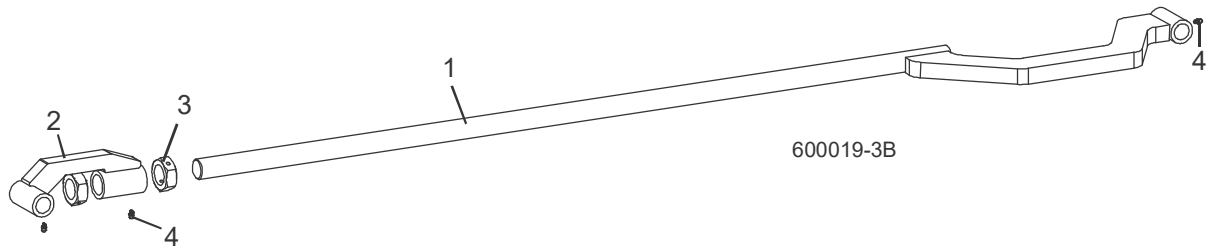

REF	PART #	DESCRIPTION	COMMENTS	QTY.
1	034725	ROD WELDMENT, SIDE SUPPORT LINK		1
2	106869	ARM WELDMENT, SIDE SUPPORT LINK		1
3	F05010-100	NUT, 1 1/4"-12 HEX JAM		2
4	P04107	FITTING, 3/16" STRAIGHT GREASE		3

9.9 Hydraulic Log Clamp

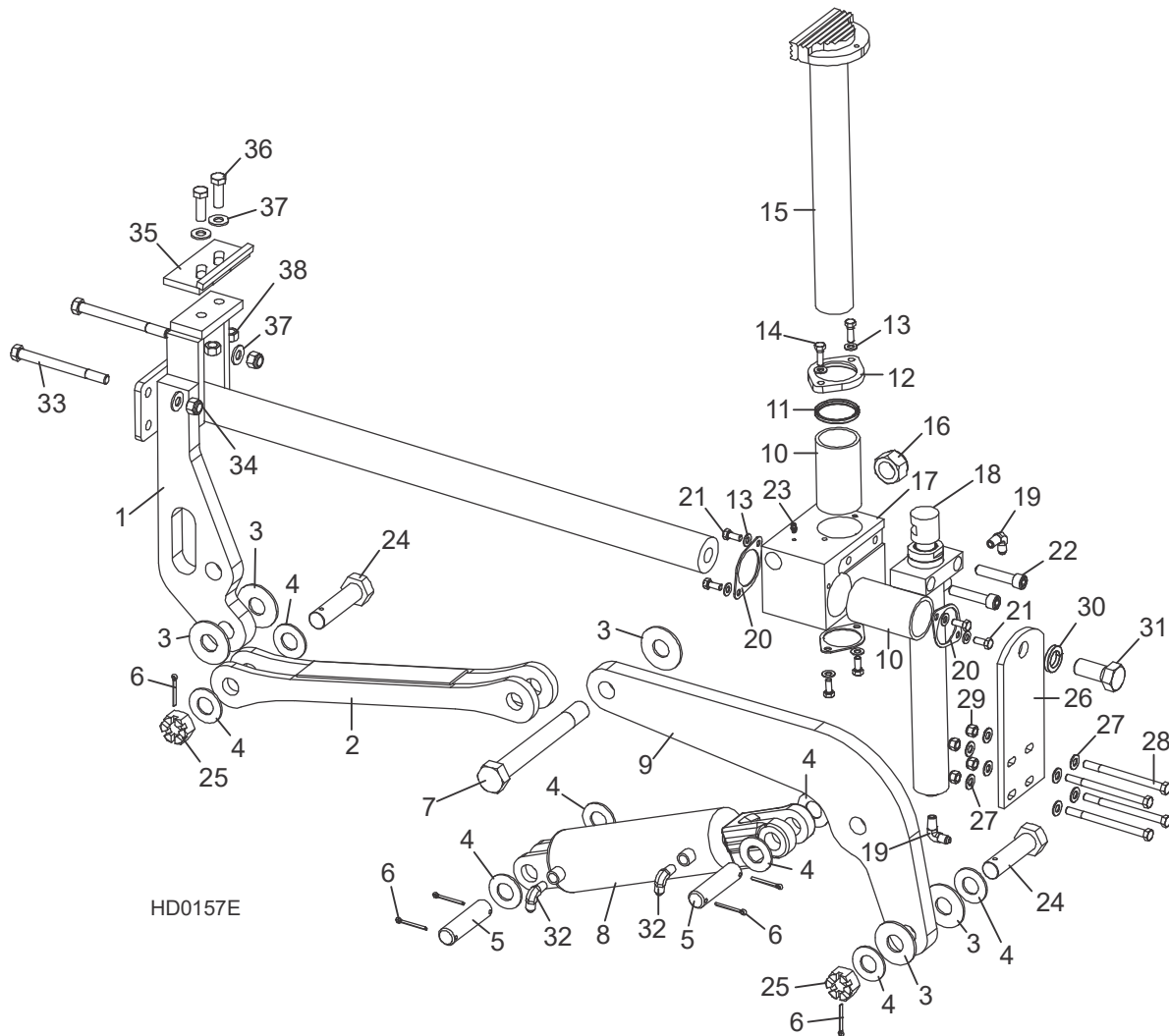

REF	PART #	DESCRIPTION	COMMENTS	QTY.
	017264	CLAMP ASSEMBLY, HYDRAULIC 2-PLANE		1
1	017265	Mount Weldment, Hydraulic Clamp Slide		1
2	017267	Link Weldment, Hydraulic Clamp		1
3	015057	Washer, 1/8" x 2 1/2" Hardened		5
4	F05011-28	Washer, 1" SAE Flat		8
5	S09251	Pin, 1" x 3.88"		2
6	F05012-23	Pin, 3/16" x 1 1/2" Cotter		6
7	015049	Bolt, 1-14 x 8 1/2" Hex Head Grade 8		1
8	017275	Cylinder, 3" x 7" Hydraulic		1
	061365	Seal kit for Bailey Cyl. 017275		
	P12956	Seal Kit, Hydraulic Cylinder	P129956 used for J-D Cyl. (Identify by notched gland retaining nut)	1
9	017274	Arm, Clamp Pivot		1
10	015088	Bushing, Clamp Slide		2
	017271	Wiper Assembly, Vertical Clamp Rod		1
11	017273	Wiper, Vertical Clamp Rod		1
12	017272	Flange, Vertical Clamp Rod Wiper		1

REF	PART #	DESCRIPTION	COMMENTS	QTY.
13	F05011-17	Washer, 5/16" SAE Flat		8
14	F05006-1	Bolt, 5/16-18 x 1" Hex Head		2
15	015043	Clamp Weldment, Vertical		1
16	F05010-141	Nut, 1-14 Nylon Lock		1
17	017270	Block, Hydraulic Clamp Slide		1
18	015050	Cylinder Weldment, Vertical Clamp Hydraulic		1
	061435	Seal kit for 1" Bailey Cyl. 015050	Used on Bailey Cyl. after 8/19	1
	016204	Seal Kit, Hydraulic Cylinder		1
	016204-1009	Instruction Sheet, Vertical Clamp Seal Replacement		1
19	074543	Fitting, 4SAE-4JIC 90° Elbow	Fitting, 1/4" NPT x 1/4" JIC Elbow P09142 was replace with 074543 as of 11/6/2020, per ECN 37711.	2
20	017242	Retainer, Clamp Bushing		3
21	F05006-5	Bolt, 5/16-18 x 3/4" Hex Head		6
22	F05008-39	Bolt, 1/2-13 x 2 1/2" Socket Head		2
23	P04107	Fitting, 3/16" Straight Grease		1
24	015072	Bolt, 1-14 x 3 3/4" Hex Head Grade 8 w/Hole		2
25	F05010-163	Nut, 1-14 Slotted Hex		2
26	015068	Plate, Log Clamp Mount		1
27	F05011-3	Washer, 3/8" SAE Flat		8
28	F05007-5	Bolt, 3/8-16 x 5" Hex Head		4
29	F05010-10	Nut, 3/8-16 Hex Nylon Lock		4
30	F05011-46	Washer, 7/8" Split Lock		1
31	F05014-2	Bolt, 7/8-14 x 2" Hex Head Grade 5		1
32	015491	Fitting, 1/4" NPT - 3/8" JIC Elbow		2
33	F05008-28	Bolt, 1/2-13 x 5 1/2" Hex Head Grade 5		2
34	F05010-8	Nut, 1/2-13 Hex Nylon Lock		2
	K09485	Clamp Stop Kit, Hydraulic Log		1
35	W09404	Plate, Clamp Stop		1
36	F05008-33	Bolt, 1/2-13 X 1 1/2" Hex Head Grade 5		2
37	F05011-2	Washer, 1/2" SAE Flat		2
38	F05010-3	Nut, 1/2-13 Hex Lock		2

9.10 Hydraulic Toe Board

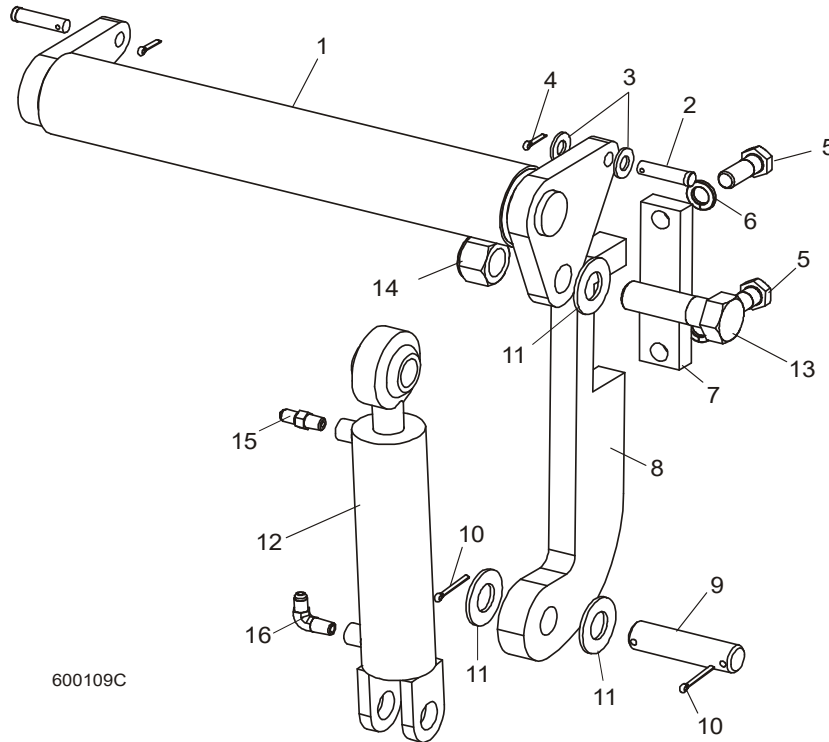

REF	PART #	DESCRIPTION	COMMENTS	QTY.
1	074842	TOE BOARD ASSEMBLY, HYDRAULIC		2
2	F05012-82	PIN, 1/2-1 3/4 CLEVIS		4
3	F05011-2	WASHER, 1/2" SAE FLAT		4
4	F05012-3	PIN, 1/8 X 3/4" COTTER		4
5	F05009-33	BOLT, 5/8-11 X 1 3/4" HEX HEAD		4
6	F05011-27	WASHER, 5/8" SPLIT LOCK		4
7	S13023	PLATE, HYDRAULIC TOEBOARD MOUNT		2
8	S13022	BRACKET, HYDRAULIC TOEBOARD MOUNT		2
9	S09251	PIN, CYLINDER MOUNT		2
10	F05012-23	PIN, 3/16" X 1 1/2" COTTER		4
11	F05011-28	WASHER, 1" SAE FLAT		6
12	014482	CYLINDER, 1 1/2" X 6" HYDRAULIC TOE BOARD		2
	014547	Seal Kit, 1 1/2" x 6" Hydraulic Cylinder		1
13	F05009-51	BOLT, 1-8 X 3 1/4" HEX HEAD GRADE 5		2
14	F05010-109	NUT, 1-8 HEX NYLON LOCK		2
15	P09143	FITTING, 1/4" NPT X 1/4" JIC MALE		2
16	P09142	FITTING, 1/4" NPT X 1/4" JIC MALE ELBOW		2

SECTION 10 MISCELLANEOUS

10.1 Replacement Manuals



REF	DESCRIPTION (◆ Indicates Parts Available In Assemblies Only)	PART #	QTY.
Wood-Mizer Product Information			
1	ALL-PRODUCTS CATALOG	PS750	1
Basic Sawmill Manuals			
2	TRU-SHARP BLADE HANDBOOK	M600	1
3	WOOD-MIZER GENERAL INFORMATION	M601	1
4	LT50HD OPERATOR'S MANUAL	M1661	1
5	LT50HD-WR WIRELESS OPERATOR'S MANUAL	M1663	1
6	LT50HD PARTS MANUAL	M1660	1
7	LT50HD-WR WIRELESS PARTS MANUAL	M1662	1
Power Option Manuals			
8	E25 MOTOR OPTION MANUAL	M772	1
9	G38 ENGINE OPTION MANUAL	M1305	1
10	D47 ENGINE OPTION MANUAL	M1584	1
11	D51 ENGINE OPTION MANUAL	M1163	1
Trailer Option Manuals			
12	ELECTRIC BRAKE TRAILER OPTION	M796	1
13	SURGE BRAKE TRAILER OPTION	M794	1
14	SUPER ELECTRIC BRAKE TRAILER OPTION	M797	1
15	SUPER SURGE BRAKE TRAILER OPTION	M795	1
Miscellaneous Option Manuals			
16	SHINGLE/LAPSIDER OPTION MANUAL	M621	1
17	OPERATOR'S SEAT OPTION MANUAL	M613	1
18	RESAW ATTACHMENT OPTION MANUAL	M263	1
19	BED EXTENSION OPTION MANUAL	M294	1
20	MKII DEBARKER ATTACHMENT OPTION MANUAL	M546	1
21	ACCUSET 2 OPTION MANUAL	M1517	1
22	LASER SIGHT OPTION MANUAL	M679	1
23	AUTOCLUTCH OPTION MANUAL	M883	1
24	LUBE-MIZER OPTION MANUAL	M885	1
25	LATHE-MIZER OPTION MANUAL	M1337	1
Electrical Diagrams			
26	G38 SUPER ELECTRICAL INFORMATION	M1306	1
27	G38-WR WIRELESS ELECTRICAL INFORMATION	M1555	1

28	E25 ELECTRICAL INFORMATION	M863	1
29	E25-WR WIRELESS ELECTRICAL INFORMATION	M1554	1
30	D47 ELECTRICAL INFORMATION	M1585	1
31	D47-WR WIRELESS ELECTRICAL INFORMATION	M1587	1
32	D51 ELECTRICAL INFORMATION	M1164	1
33	D51-WR WIRELESS ELECTRICAL INFORMATION	M1553	1