

LubeMizer (Remote)Option

Safety, Installation,
Operation, & Parts Manuals

LMS-HPR (Installed Remote)	rev. A.00-E.00
LMS-RA (Boxed Remote)	rev. A.00-E.00

Safety is our #1 concern!

December 1999

Form #930



WARNING! Read and understand this manual before using this machine.

California

Proposition 65 Warning



WARNING: Breathing gas/diesel engine exhaust exposes you to chemicals known to the State of California to cause cancer and birth defects or other reproductive harm.

Always start and operate the engine in a well-ventilated area.
If in an enclosed area, vent the exhaust to the outside.
Do not modify or tamper with the exhaust system.
Do not idle the engine except as necessary.

For more information go to www.P65warnings.ca.gov.



WARNING: Drilling, sawing, sanding or machining wood products can expose you to wood dust, a substance known to the State of California to cause cancer. Avoid inhaling wood dust or use a dust mask or other safeguards for personal protection.

For more information go to www.P65Warnings.ca.gov/wood.

Active Patents assigned to Wood-Mizer, LLC

Wood-Mizer, LLC has received patents that protect our inventions which are a result of a dedication to research, innovation, development, and design. Learn more at: woodmizer.com/patents

©2024 Wood-Mizer LLC

Printed in the United States of America, all rights reserved. No part of this manual may be reproduced in any form by any photographic, electronic, mechanical or other means or used in any information storage and retrieval system without written permission from

Wood-Mizer, LLC
8180 West 10th Street
Indianapolis, Indiana 46214

SECTION 1 LUBEMIZER INSTALLATION

1.1 Remote Power Box Installation 1-1
 Rev. E.00+ Only 1-1
 Rev. A.00 - D.01 Only 1-2
 1.2 Control Box Installation 1-3
 Rev. E.00+ Only 1-3
 1.3 Pump Installation And Wiring (All LT30/LT40 Sawmills)..... 1-4
 1.4 Pump Installation And Wiring (LX450 Sawmills) 1-6
 1.5 Bottle Conversion and Hose Installation (LT30/LT40 Sawmills) 1-7
 1.6 Hose Line Installation (LX450 Sawmills) 1-8
 1.7 Finishing Steps 1-8

SECTION 2 OPERATION

2.1 The LubeMizer System 2-1
 2.2 Lube Additives 2-1

SECTION 3 MAINTENANCE

SECTION 4 REPLACEMENT PARTS

4.1 Pump Assembly (LMS-HP/LMS-A) 4-1
 4.2 Pump Assembly (LMS-LX)..... 4-3
 4.3 Filter Assembly (LMS-HP/LMS-A) 4-4
 4.4 Filter Assembly (LMS-LX) 4-5
 4.5 Blade Guide Block Assembly (LMS-A Only) 4-6
 4.6 Control Box Assembly 4-7
 LMS-A Rev A.00+
 LMS-RA Rev. E.00+
 LMS-LX Rev A.00+ 4-7

SECTION 5 ELECTRICAL INFORMATION

5.1 Electrical Components 5-1
 5.2 Electrical Wiring Diagram (Control Circuit) 5-2
 Rev. E.00+ 5-2
 Rev. A.00 - D.01 5-3

SECTION 1 LUBEMIZER INSTALLATION

1.1 Remote Power Box Installation

Rev. E.00+ Only

See the table below for sawmill application. Sawmills built after 9/04 are pre-wired for LubeMizer installation and require no wiring modifications. Sawmills built prior to 9/04 must be modified to accommodate Rev. E.00 and newer LubeMizer options.

Sawmill Model	Modification Required (See instructions below)	No Modification Required (Skip to next section)
LT40HD Remote	Rev. H4.00 - J8.03	J9.00+
LT30HD Super Remote LT40HD Super Remote	Rev. H4.00 - J7.08	J8.00+

Remote Power Box Modification

1. Raise the saw head to access the battery box. Turn the key to the OFF (#0) position and remove the key.
2. Remove the two wing nuts and flat washers holding the battery box lid to the battery box.
3. Lift and remove the battery box lid. Remove the negative (-) battery post terminal clamp.

Refer to the appropriate wiring diagram while performing the wiring steps below.

4. Locate red wire #19 inside the remote power box where it is connected to a T-tap terminal.
5. Unplug wire #19 from the terminal and cut the terminal from the end of the wire.
6. Locate black wire #20 inside the remote power box where it is connect to a T-tap terminal.
7. Unplug wire #20 from the terminal and cut the terminal from the end of the wire.
8. Strip 1/4" of insulation from the end of each wire.
9. Disconnect the harness from the connector labeled "J2".

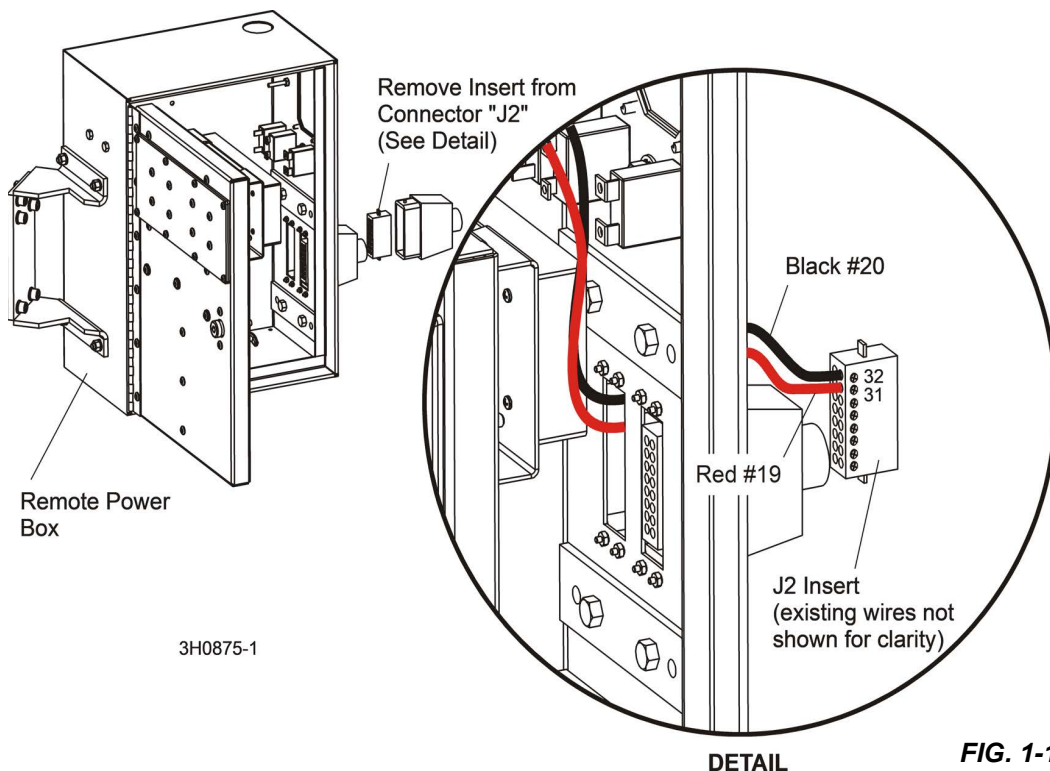

FIG. 1-1

10. Unscrew the 16-pin insert from the connector.
11. Insert red wire #19 to connector socket #31 and tighten the screw at the side of the insert.
12. Insert black wire #20 to connector socket #32 and tighten the screw at the side of the insert.
13. Reinstall the insert to the connector.
14. Reconnect the harness to the connector.

15. Proceed to Control Box Wiring Instructions ([See Section 1.2](#)).

Rev. A.00 - D.01 Only

This revision LubeMizer is designed to install to the remote power box on sawmills built before 9/04.

⚠ DANGER! The key switch should be off, the key removed and the negative battery cable disconnected as stated below. The incoming power supply of electric-powered sawmills should be disconnected and locked out. Failure to do so will result in serious injury or death.

NOTICE Avoid pinch and pivot points, unnecessary wire bending and open spaces where the wire could get caught by a log, etc. If you have any questions, call Wood-Mizer customer service.

1. Raise the saw head to access the battery box. Turn the key to the OFF (#0) position and remove the key.
2. Remove the two wing nuts and flat washers holding the battery box lid to the battery box.
3. Lift and remove the battery box lid. Remove the negative (-) battery post terminal clamp.
4. Remove the existing side panel from the remote power box. After wiring is completed, the provided control panel will be installed in its place.
5. Install the provided timer to the inside of the control box as shown.
6. Use the existing hardware as shown.

Refer to the appropriate wiring diagram while performing the wiring steps below.

1. Locate red wire #19 inside the remote power box where it is connected to a T-tap terminal.
2. Unplug wire #19 from the terminal and plug red lube wire #250 in its place.
3. Connect red lube wire #251 to wire #19.
4. Locate black wire #20 inside the remote power box where it is connect to a T-tap terminal.
5. Unplug wire #20 from the terminal and plug black lube wire #259 in its place.
6. Connect blue lube wire #257 to wire #20.
7. Using the existing mounting bolts, secure the control panel to the side of the remote power box.

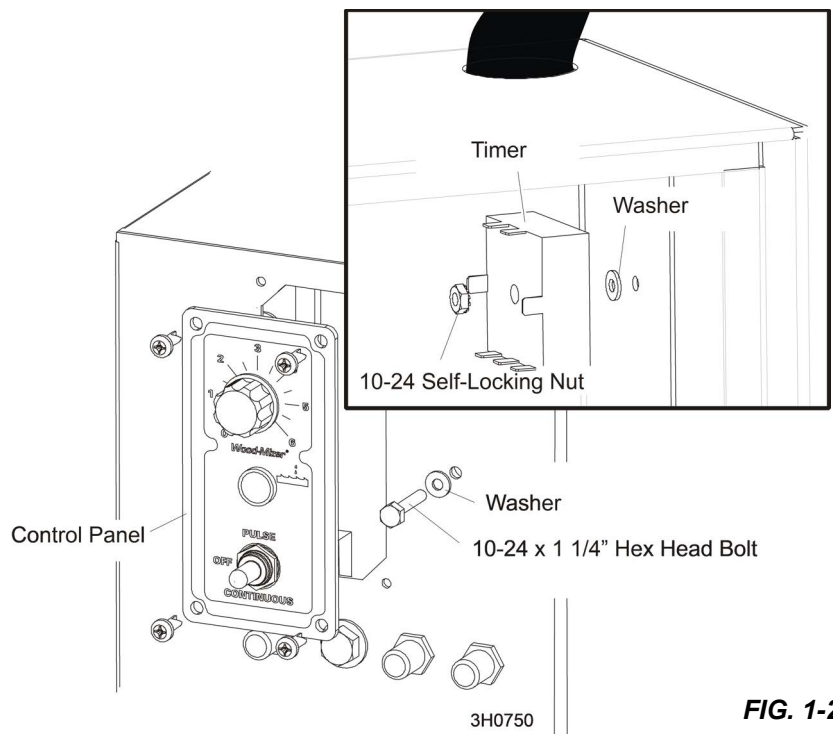

FIG. 1-2



STOP! You have completed Control Box Wiring. Proceed to Section 1.3 Pump Installation And Wiring (All LT30/LT40 Sawmills).

1.2 Control Box Installation

Rev. E.00+ Only:



DANGER! The key switch should still be off, the key removed and the negative battery cable disconnected as stated at the beginning of this section. The incoming power supply of electric-powered sawmills should be disconnected and locked out. Failure to do so will result in serious injury or death.

NOTICE Avoid pinch and pivot points, unnecessary wire bending and open spaces where the wire could get caught by a log, etc. If you have any questions, call Wood-Mizer customer service.

1. Remove the rear panel assembly from the control box.
2. Remove the left control box side panel from the sawmill control box.
3. Position the LubeMizer control near the opening and connect as described below.

After wiring, the lube control assembly will be secured in place.

Refer to the appropriate wiring diagram while performing the wiring steps below.

1. Connect the red LubeMizer wire #250 to the short red wire connected to terminal #3 of the power feed drum switch.
2. Connect red LubeMizer wire #251 to red sawmill control harness wire #19 (clear #41 on sawmills before 9/04).
3. Connect blue LubeMizer wire #257 to black sawmill control harness wire #20 (black #42 on sawmills before 9/04).
4. Connect black LubeMizer wire #259 to the ground stud terminal in the control box.
5. Using the existing mounting bolts, install the lube control assembly to the sawmill control box.
6. Replace the rear control box panel.

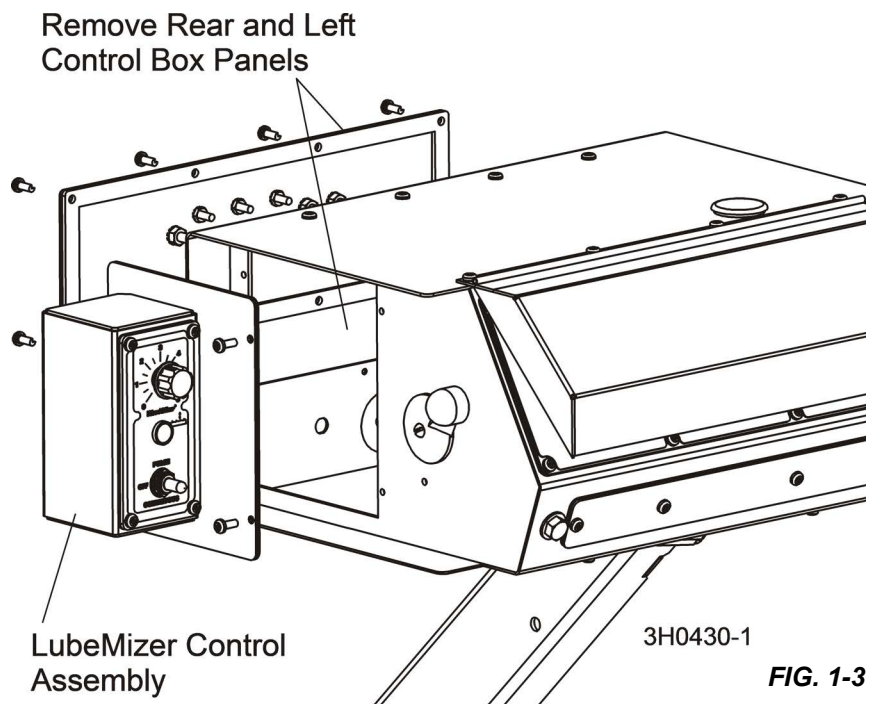

1.3 Pump Installation And Wiring (All LT30/LT40 Sawmills)

NOTE: See [See Section 1.4](#) for the LX450 mill pump installation and wiring instructions.

1. Remove the drive pulley guard from the sawmill as shown in FIG.1-4.

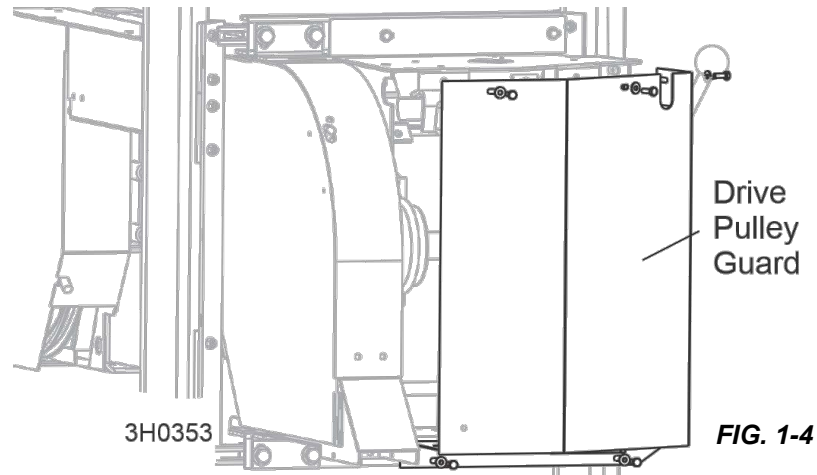

2. Remove the drive-side blade housing cover from the sawmill as shown in FIG.1-5.
3. Remove all 3/8" water lube hose from the mill.
4. Remove the water bottle and fuel tank from the mill and set aside.

5. **For Super Mills Only:**

- a. Disconnect the red and black sawmill harness wires from the existing water solenoid valve.
- b. Remove the valve from the mill.

NOTE: This step also applies to Standard mill owners who have installed Water Solenoid Valve Kit 016141.

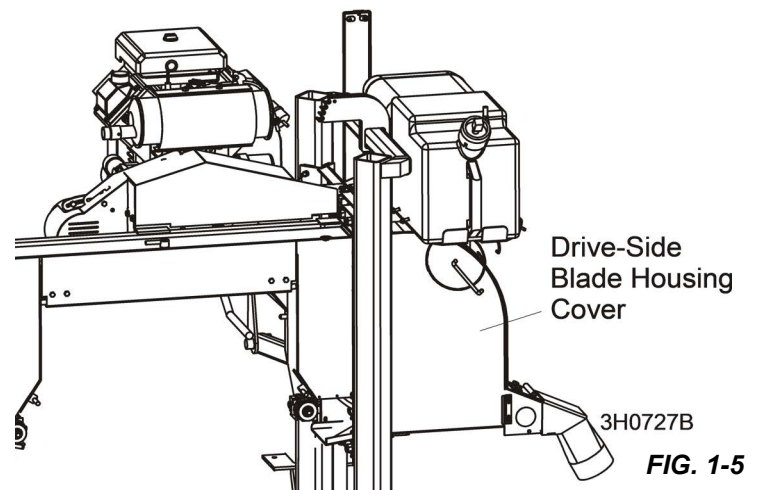

If the sawmill is not equipped with a water solenoid valve, the wires for the LubeMizer option are stored underneath the water tank tray.

- c. Locate wires #19 and #20 and remove any electrical tape to expose the terminals on the end of the wires.
6. Install the lube pump assembly to the mill as shown using the existing fuel/water mounting plate bolts and nuts.

NOTE: On older revision mills, the front bolt will be shorter. Replace this shorter bolt with the supplied longer, 1/4-20 x 3/4" bolt.

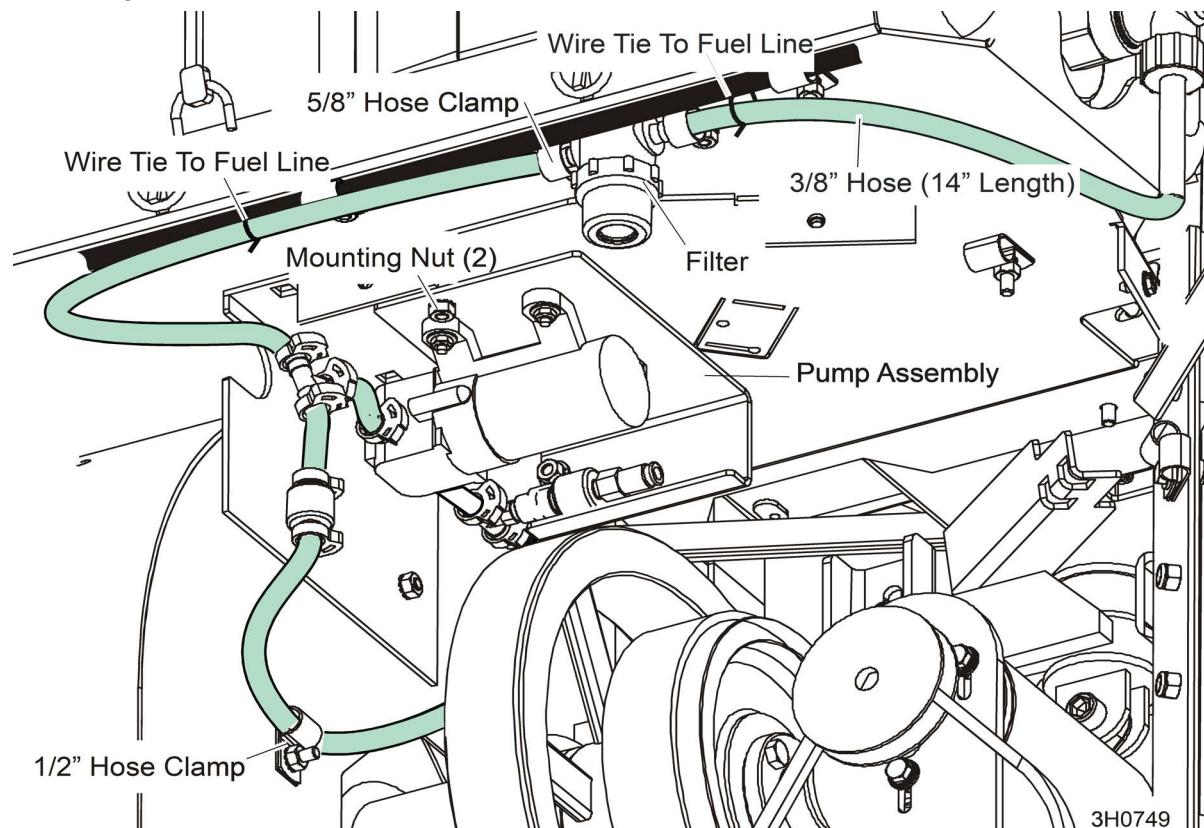
**FIG. 1-6**

7. Use the provided 1/4-20 x 3/4" hex head bolt and 1/4-20 self locking nut to secure the 1/2" hose clamp to the back of the blade housing as shown.

NOTE: Older revision mills do not have a hole in this location. Locate and drill one 9/32" hole as shown in FIG. 1-8. Be sure to unbolt the main fuel line hose clamps shown in FIG. 1-6 and move the fuel line hose out of the way before drilling.

8. Install the provided 14" length of 3/8" lube hose and the provided 5/8" hose clamp to the filter.
9. Using the provided 1/4-20 carriage bolts and 1/4-20 locking nuts, secure the 5/8" hose clamps on either side of the filter in place.
10. Be sure to install the carriage bolts from the top.

NOTE: Older revision mills do not have holes in this location. Locate and drill two 3/8" diameter holes in the as shown in FIG. 1-8.

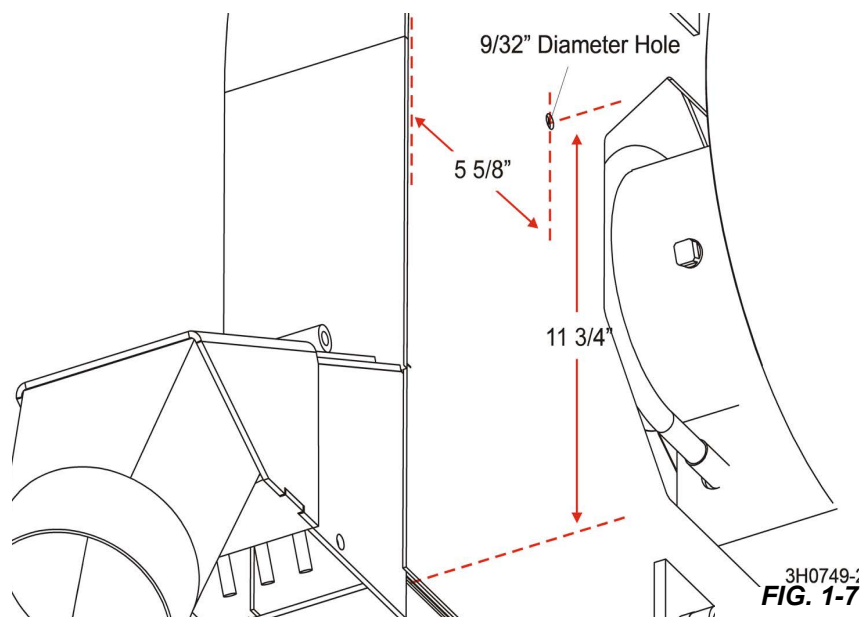
**FIG. 1-7**

11. Connect the remaining end of the 3/8" lube hose to the water bottle.
12. Use wire ties as necessary to secure the lube hose out of the way of moving sawmill components.



DANGER! Be sure the engine is off or the electricity locked out. Failure to do so will result in serious injury of death.

NOTICE Avoid pinch and pivot points, unnecessary wire bending and open spaces where the wire could get caught by a log, etc. If you have any questions, call Wood-Mizer customer service.

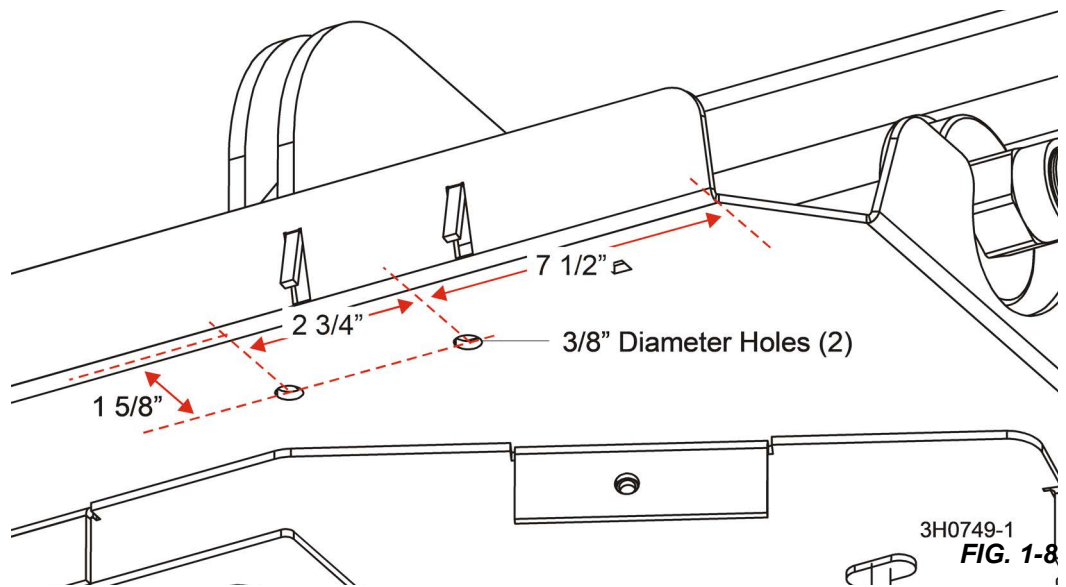

3H0749-1
 FIG. 1-8

13. Connect black sawmill harness wire #20 to the black pump harness wire.
14. Connect red sawmill harness wire #19 to the red pump harness wire.
15. After making all wire connections, use the provided wire ties to secure the wires out of the way.

1.4 Pump Installation And Wiring (LX450 Sawmills)

1. Remove all 3/8" water lube hoses from the mill.
2. Remove the fuel tank from the mill and set aside.
3. Disconnect the red and black sawmill harness wires from the existing water solenoid valve.
4. Remove the valve from the mill.
5. Install the lube pump assembly to the mill using the provided bolts and nuts.



DANGER! Be sure the engine is off or the electricity locked out. Failure to do so will result in serious injury of death.

NOTICE Avoid pinch and pivot points, unnecessary wire bending and open spaces where the wire could get caught by a log, etc. If you have any questions, call Wood-Mizer customer service.

6. Connect black sawmill harness wire #20 to the black pump harness wire.
7. Connect red sawmill harness wire #19 to the red pump harness wire.
8. After making all wire connections, use the provided wire ties to secure the wires out of the way.

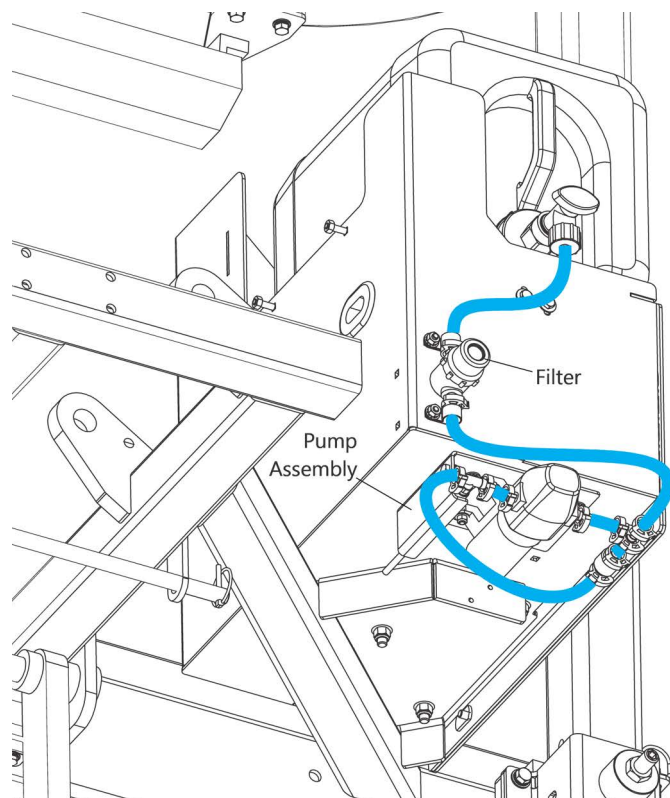

LX0077-2
 FIG. 1-9

1.5 Bottle Conversion and Hose Installation (LT30/LT40 Sawmills)

1. Reinstall the bottle to the mill.
2. Reinstall the fuel bottle. If necessary, resecure the fuel line hose clamps.
3. Remove the entire blade guide roller and block assembly from the sawmill.
4. **Sawmills equipped with Roller-Only blade guides:** Remove the roller from the block and install it to the provided lube blade guide block assembly.
5. Wrap the threads of the provided fittings, nozzles and plug with teflon tape (pipe tape) and install the components to the blade guide block as shown in FIG. 1-10. (An extra nozzle is provided for service replacement.)
6. **Sawmills equipped with Roller-Only blade guides:** Install the lube block assembly to the mill.
7. Orient the nozzles so that oil flow is directed on the blade.
8. Locate the provided 1/4" hose. Insert one end to the pump valve as shown in FIG. 1-10.
9. Route the hose through 1/2" hose clamp.
10. Continue routing through the grommet in the motor mount and connect the remaining end to the fitting on the block assembly.
11. Use wire ties to secure the hose near the motor mount and again at the block assembly as shown in FIG. 1-11.

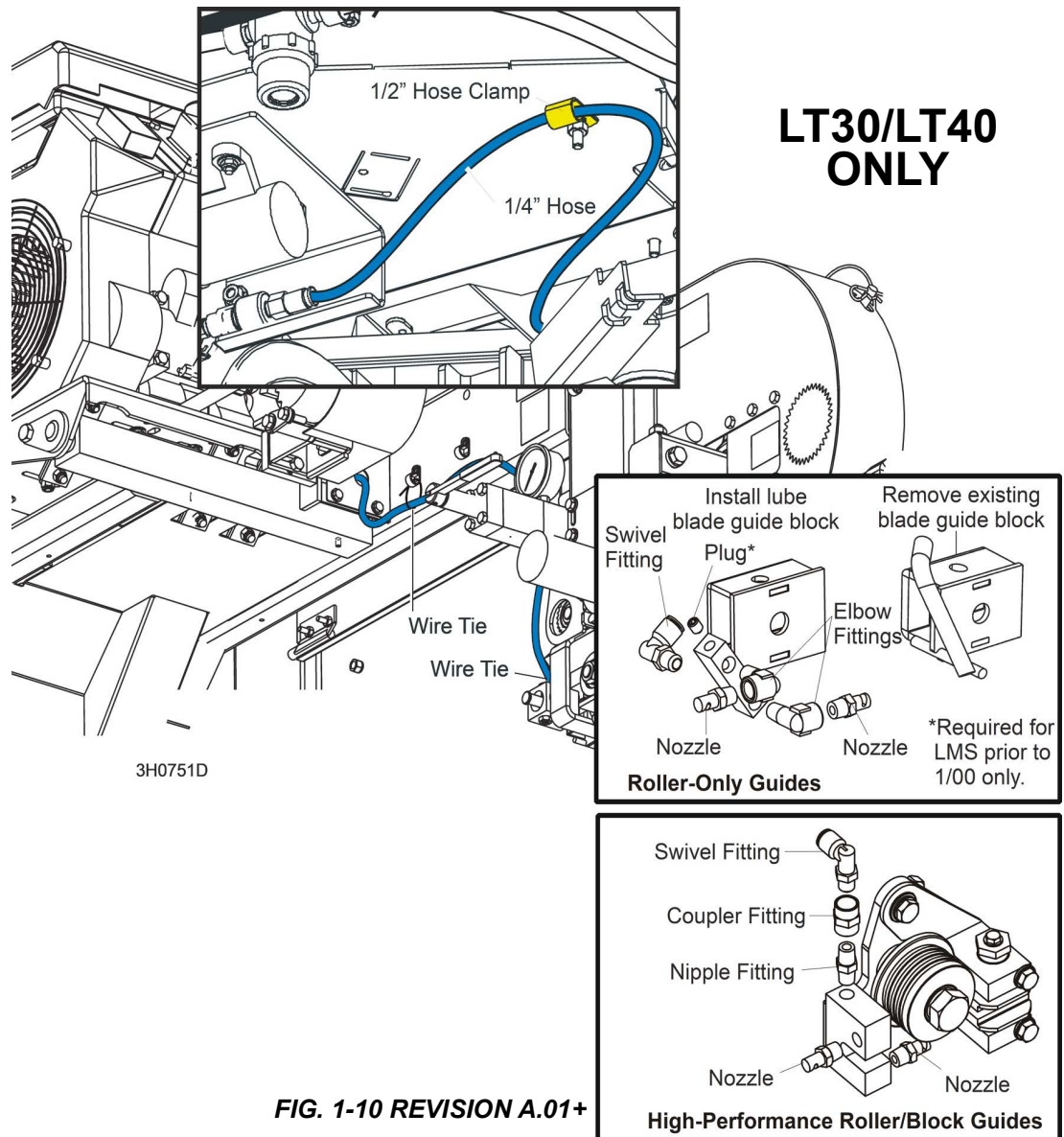

FIG. 1-10 REVISION A.01+

1.6 Hose Line Installation (LX450 Sawmills)

1. Reinstall the fuel tank; if necessary, resecure the fuel line hose clamps.
2. Locate the provided 1/4" hose.
3. Insert one end to the pump valve as shown in FIG. 1-11.
4. Route the hose and connect the remaining end to the fitting on the block assembly.

1.7 Finishing Steps



DANGER! Make sure all guards and covers are in place and secured before operating or towing the sawmill. Failure to do so may result in serious injury.

Be sure the blade housing and pulley covers are in place and secure. Use the safety retainer pin and cable to fasten blade housing covers.

1. **LT30/LT40 Only:** Reinstall the drive side blade housing cover and left pan cover.
2. Reconnect the negative battery terminal cable and replace the battery box cover.
3. Align the inner blade guide assembly as instructed in the alignment section of your Wood-Mizer Operator's Manual.

After blade guide alignment, be sure to check the scale indicator to make sure it is adjusted properly (procedure also found in the alignment section of your Wood-Mizer Operator's Manual).

4. Fill the water lube bottle with clean water.

Avoid using water that might contain foreign substances such as algae, dirt, or minerals that can damage the pump or clog the check valves.

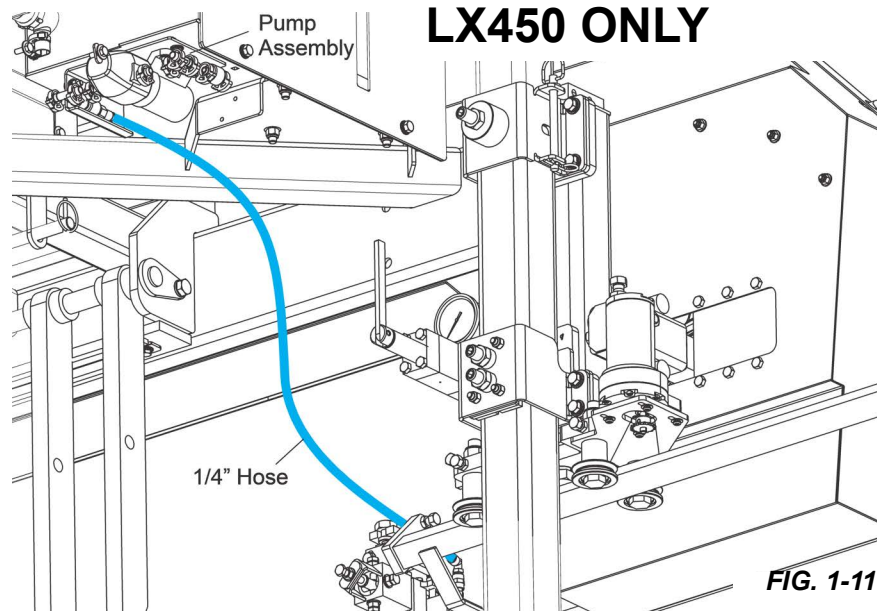

FIG. 1-11

SECTION 2 OPERATION

2.1 The LubeMizer System

The LubeMizer system utilizes an automatic valve to activate the lubricant flow only when the saw carriage is moving forward. The LubeMizer control box adjusts the volume of lubricant for various wood types. The LubeMizer option uses less lubricant, helping to reduce lubricant/sawdust mess and waste, and to prevent stained boards.

Usual flow will be between 0.07 and 2.5 gallons (2.6 - 9.5 liters) per hour.

START THE SELF-PRIMING SYSTEM

1. Open the water lube bottle valve all the way.
2. Turn the sawmill control box key to the ACC or ON position.
3. Turn the lube control switch to PULSE¹ and set the lube dial to the desired flow rate.
4. Use the lowest setting that successfully eliminates pitch buildup.

NOTE: Softwood applications will usually require more lubricant than hardwood applications.

5. Cut the log as normal.

SHUT OFF THE LUBE

1. Turn the lube control switch to OFF.
2. Close the lube bottle valve all the way.

NOTE: If you are sawing or storing the sawmill in freezing temperatures, use windshield washer fluid to help prevent the water from freezing ([See Section 2.2](#)).

CAUTION! Add windshield washer fluid to the water tank and prime as recommended when sawing or storing the sawmill in below-freezing temperatures. Use windshield washer fluid with a freezing point of at least -20°F (-29°C). Failure to do so will cause damage to the LubeMizer system may result.

2.2 Lube Additives

For further benefits, add 12oz. of Wood-Mizer Lube Additive to a 5 gallon jug of water. Wood-Mizer Lube Additive significantly reduces resin buildup on the blade. It helps to reduce heat buildup, wavy cuts, and blade noise. This biodegradable and environmentally friendly pre-mix includes a water softener additive for hard water.

WARNING! Use ONLY water, Wood-Mizer Lube Additive or windshield washer fluid with the water lube accessory. Never use flammable fuels or liquids such as diesel fuel. If these types of liquids are necessary to clean the blade, remove it and clean with a rag. Failure to do so can damage the equipment and may result in serious injury or death.

Use windshield washer fluid as an antifreeze to prevent the water from freezing and damaging the LubeMizer system. See the chart below for recommended mixture levels depending on the temperature where you are sawing or storing the sawmill.

Run the LubeMizer system on the "Continuous" setting for 30 seconds after adding the windshield washer fluid to the system. This will insure the water throughout the system will not freeze and damage the check valves.

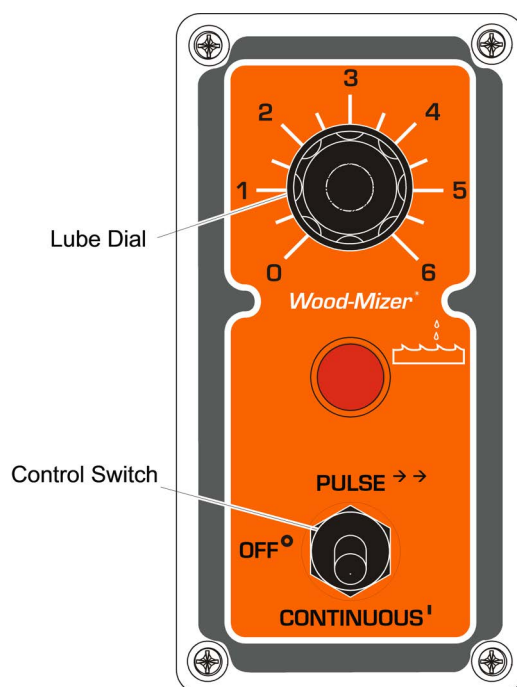

FIG. 2-1

¹. Pulse is suitable for most cutting applications. CONTINUOUS delivers a steady stream of lubricant and should be used only for heavy pitch buildup or occasional blade cleaning.



CAUTION! Add windshield washer fluid to the water tank and prime as recommended when sawing or storing the sawmill in below-freezing temperatures. Use windshield washer fluid with a freezing point of at least -20°F (-29°C). Failure to do so may cause damage to the LubeMizer system.

Ratio WWF:Water to fill 5 Gal. tank	Freezing Point Of Solution	
	(°F)	(°C)
5:0	-22	-30
4:1	-3	-19
3:2	7	-14
2.5:2.5	13	-10
1:4	24	-4
0:5	32	0

TABLE 2-1

SECTION 3 MAINTENANCE



DANGER! On electric mills, hazardous voltage inside the disconnect box, starter box, and at the electric motor can cause shock, burns, or death. Disconnect and lock out power supply before performing service! Follow all applicable electrical codes.

DANGER! Make sure all electrical installation, service and/or maintenance work is performed by a qualified electrician and is in accordance with applicable electrical codes. Failure to do so will result in serious injury or death.

DANGER! Before performing any service to this equipment, turn the key to the OFF position, remove the key, and disconnect the battery ground terminal. Failure to do so will result in serious injury or death.

CLEAN THE LUBE FILTER.

1. Make sure the lube control is in the OFF position and the lube bottle valve is closed all the way.
2. Unscrew the filter reservoir and flush with water.
3. Remove the cylindrical mesh filter and gently flush with water.

REPLACE THE FILTER AND RESERVOIR

1. Periodically check lube hoses and lines for buildup.
2. Remove and flush with water as needed.
3. Periodically check the blade guide bracket nozzles for buildup.
4. Remove and flush with water as needed.

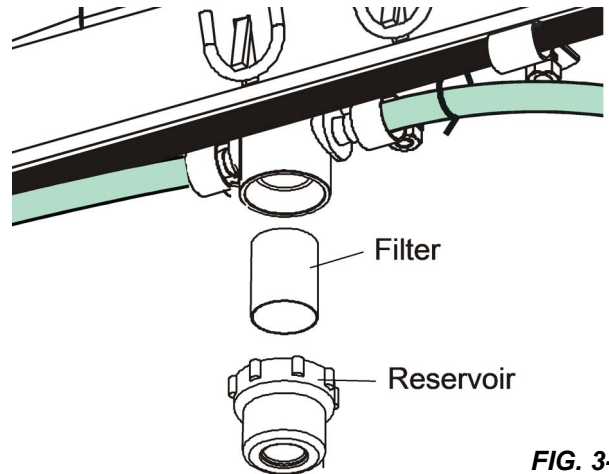
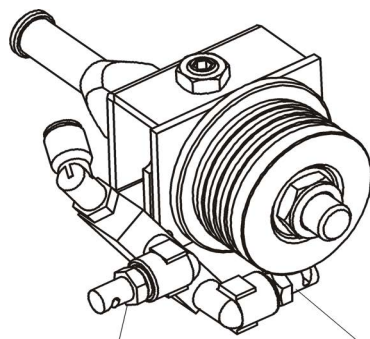

FIG. 3-1



Nozzle

Nozzle

REVISION A.00 3H0753

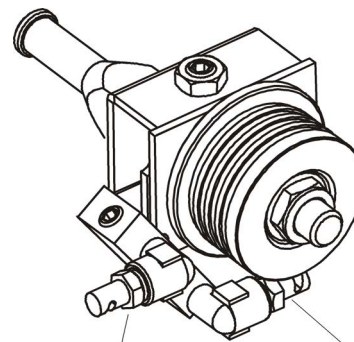

Nozzle

Nozzle

FIG. 3-2 REVISION A.01+

SECTION 4 REPLACEMENT PARTS

4.1 Pump Assembly (LMS-HP/LMS-A)

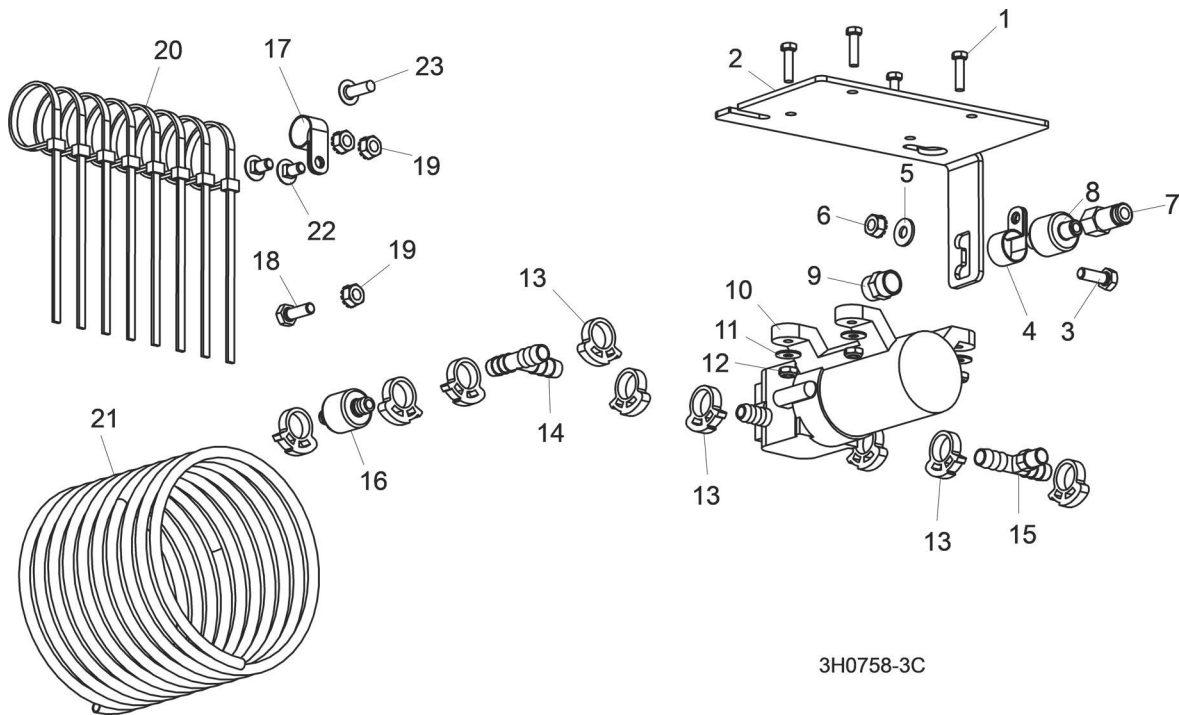

REF	PART #	DESCRIPTION	COMMENTS	QTY.
1	F05004-167	BOLT, #10-24 X 3/4" UNSLOTTED HEX HEAD		4
2	130780	PLATE, PUMP MOUNTING	ECN:37797:130780 Was 033494 .	1
3	F05005-1	BOLT, 1/4-20 X 3/4" HEX HEAD FULL THREAD	Replaces F05005-15 1/4-20 x 1/2" Hex Head Bolt originally supplied prior to 11/99. Longer bolt easier to assemble.	1
4	010748	CLAMP, 1/2" EMT COATED		1
5	F05011-11	WASHER, 1/4" SAE FLAT		1
6	F05010-9	NUT, 1/4-20 SELF LOCKING		1
7	033450	FITTING, 1/4" TUBE X 1/8" NPT MALE AIR		1
8	033449	VALVE, 1/8" NPT 3PSI CHECK		1
9	P05748	FITTING, 1/8" FPT COUPLING		1
10	033492	PUMP ASSEMBLY, PRESSURE LUBE		1
	033442	Head Kit, Pressure Lube Pump		1
	024123	Diode Assembly, Inductive Kick Protection	Added Rev. C.00 to protect power feed control circuit. Use kit 050805 to retrofit earlier revisions.	1
	074750	Fitting, Pump 12VDC Feed		1
11	F05011-18	WASHER, #10 SAE FLAT		4
12	F05010-160	NUT, #10-24 HEX SELF LOCKING		4
13	016845	CLAMP, SINGLE SNAP GRIP #38	Replaces 033453 clamps originally supplied prior to Rev. D.01. Hoses replaced with fiber-reinforced hose to eliminate kinking.	9
14	033451	FITTING, 3/8" BARB TEE CONNECTOR		1

REF	PART #	DESCRIPTION	COMMENTS	QTY.
15	033452	FITTING, 3/8" X 1/8" NPT MALE BRANCH TEE		1
16	033448	VALVE, 3/8" BARB 6 PSI CHECK		1
17	010748	CLAMP, 5/8" EMT COATED		1
18	F05005-1	SCREW, 1/4-20 X 3/4" FULL THREAD HEX HEAD CAP		1
19	F05010-9	NUT, 1/4-20 SELF LOCKING		1
20	F05089-3	TIE WRAP, 3/16 X 5 1/2" UV BLACK		7
21	033456	HOSE, 1/4" OD X 8.5'	Hose length changed from 5' to 8.5' 7/05 to accommodate LT70 model. Cut hose to length as necessary.	1
22	F05005-33	BOLT, 1/4-20 X 1/2" CARRIAGE		2
23	F05005-138	SCREW, 1/4-20 X 3/4" PHILLIPS ROUND HEAD		1
	107942	HOSE, 1/4ODX50 (LX450 ONLY)		1
	F05005-113	BOLT, 1/4-20X3/4 CARRIAGE	(LX450 ONLY)	4

4.2 Pump Assembly (LMS-LX)

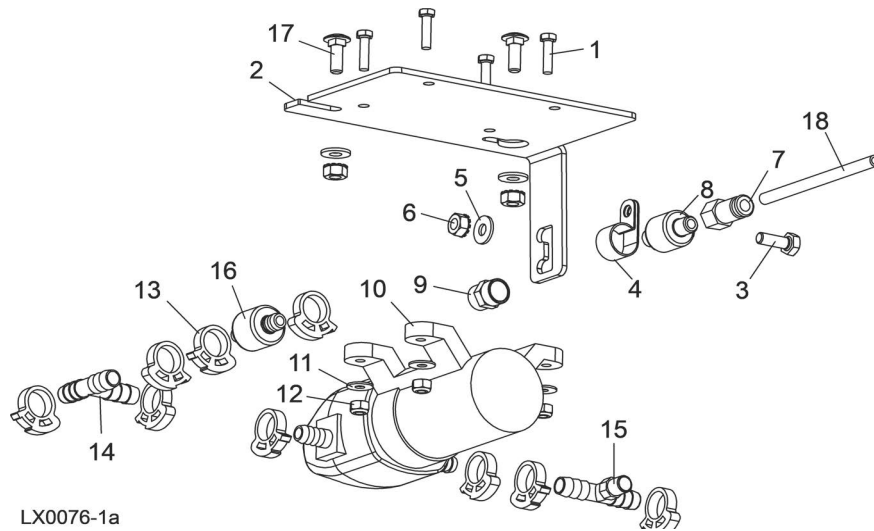

REF	PART #	DESCRIPTION	COMMENTS	QTY.
1	F05004-167	BOLT, #10-24 X 3/4" UNSLOTTED HEX HEAD		4
2	130780	PLATE, PUMP MOUNTING	ECN:37797:130780 Was 033494.	1
3	F05005-1	BOLT, 1/4-20 X 3/4" HEX HEAD FULL THREAD		1
4	010748	CLAMP, 1/2" EMT COATED		1
5	F05011-11	WASHER, 1/4" SAE FLAT		3
6	F05010-9	NUT, 1/4-20 SELF LOCKING		3
7	033450	FITTING, 1/4" TUBE X 1/8" NPT MALE AIR		1
8	033449	VALVE, 1/8" NPT 3PSI CHECK		1
9	P05748	FITTING, 1/8" FPT COUPLING		1
10	033492	PUMP ASSEMBLY, PRESSURE LUBE		1
	033442	Head Kit, Pressure Lube Pump		1
	024123	Diode Assembly, Inductive Kick Protection		1
	074750	Fitting, Pump 12VDC Feed		1
11	F05011-18	WASHER, #10 SAE FLAT		4
12	F05010-160	NUT, #10-24 HEX SELF LOCKING		4
13	016845	CLAMP, SINGLE SNAP GRIP #38		9
14	033451	FITTING, 3/8" BARB TEE CONNECTOR		1
15	033452	FITTING, 3/8" X 1/8" NPT MALE BRANCH TEE		1
16	033448	VALVE, 3/8" BARB 6 PSI CHECK		1
17	F05005-113	BOLT, 1/4-20X3/4 CARRIAGE		4
18	107942	HOSE, 1/4ODX50		1

4.3 Filter Assembly (LMS-HP/LMS-A)

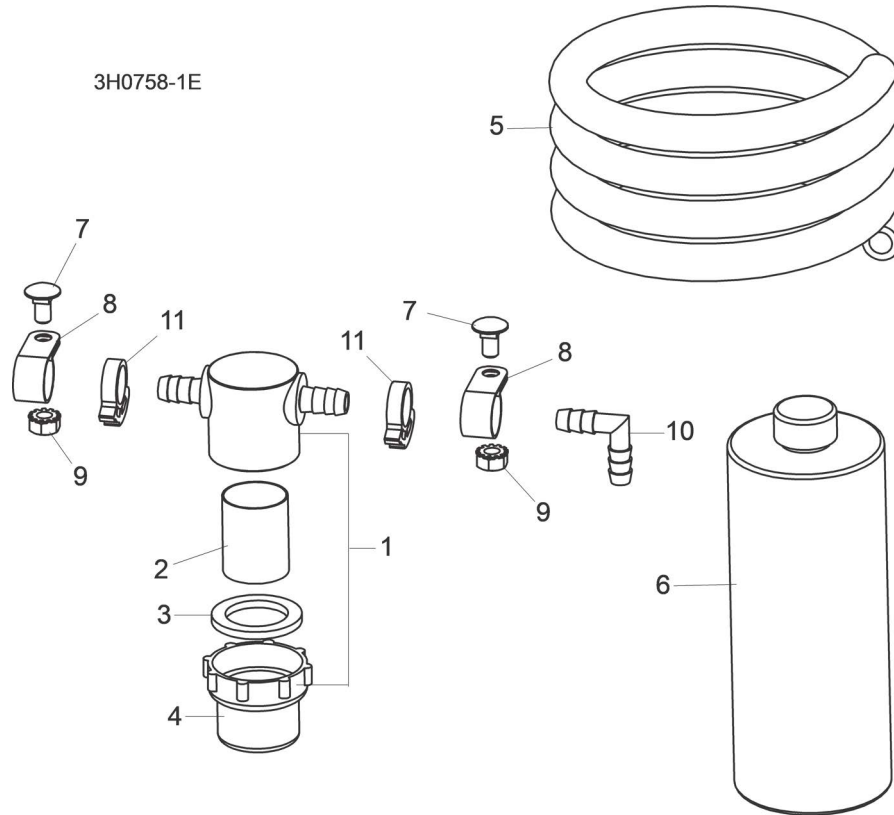

REF	PART #	DESCRIPTION	COMMENTS	QTY.
1	033447	FILTER, PRESSURE LUBE		1
2	033441	Screen Kit, Mesh Filter		1
3	061768	Gasket, Filter Bowl		1
4	003198	Bowl, LubeMizer Filter Replacement		1
5	033455	HOSE, 3/8" X 9/16" X 14"	Hoses changed to fiber-reinforced hose to eliminate kinking (Rev. D.01). Requires nine clamps 016845 to retrofit previous revisions.	1
	033446	HOSE, 3/8" X 9/16" X 4'		1
6	ADD-1	LUBRICANT, 4-PAK 60 OZ. BOTTLES LUBEMIZER	Single 60 oz. bottle 039422 no longer available. Use 4-pak 60 oz. bottle ADD-1.	1
7	F05005-33	BOLT, 1/4-20 X 1/2" CARRIAGE		2
8	010748	CLAMP, 5/8" EMT COATED		2
9	F05010-9	NUT, 1/4-20 SELF-LOCKING		2
10	028420	FITTING, 3/8" HOSE BARB ELBOW	Elbow fitting added Rev. A.02 to eliminate kink in hose between filter and 'T' fitting.	1
11	016845	CLAMP, SINGLE SNAP GRIP #38		2

4.4 Filter Assembly (LMS-LX)

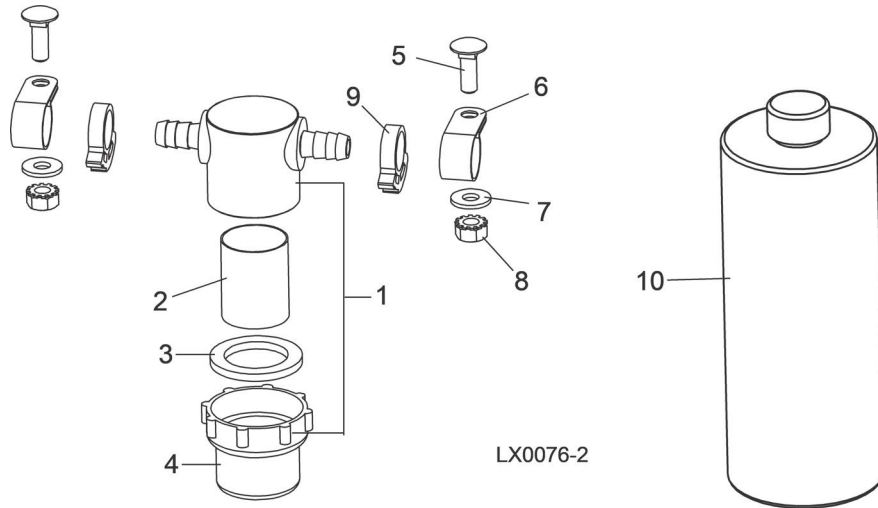

REF	PART #	DESCRIPTION	COMMENTS	QTY.
1	033447	FILTER, PRESSURE LUBE		1
2	033441	Screen Kit, Mesh Filter		1
3	061768	Gasket, Filter Bowl		1
4	003198	Bowl, LubeMizer Filter Replacement		1
5	F05005-113	BOLT, 1/4-20 X 3/4 CARRIAGE		2
6	010748	CLAMP, 5/8" EMT COATED		2
7	F05011-11	WASHER, 1/4 SAE FLAT		2
8	F05010-9	NUT, 1/4-20 SELF-LOCKING		2
9	016845	CLAMP, SINGLE SNAP GRIP #38		2
10	ADD-1	LUBRICANT, 4-PAK 60 OZ. BOTTLES LUBEM-IZER		1

4.5 Blade Guide Block Assembly (LMS-A Only)

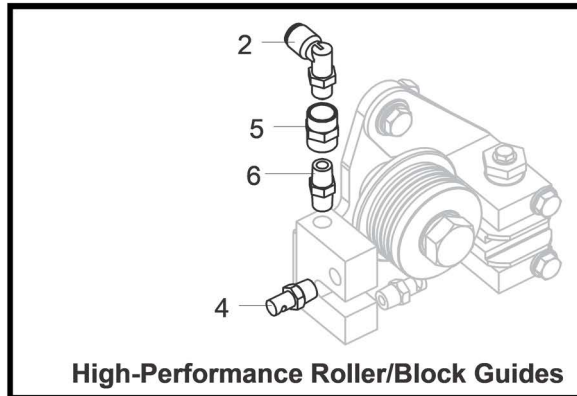
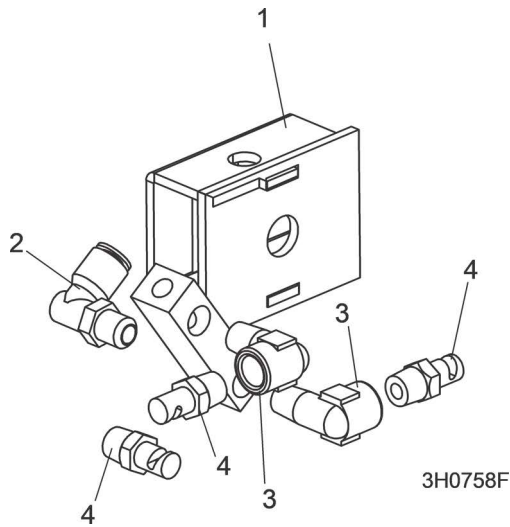

REF	PART #	DESCRIPTION	COMMENTS	QTY.
	003271	GUIDE KIT, PRESSURE LUBE		1
1	033464	Block Weldment, Pressure Lube		1
2	P09736	Fitting, 90° Elbow 1/8" MPT 1/4" Tube Swivel		1
3	033440	Fitting, 1/8" NPT Street Elbow Long		2
4	033479	Nozzle, Blade Lube Spray		3
	P09206	FITTING, 1/16" NPT PLUG	Plug removed 1/00. Hole is now plugged by weld.	1
5	P05748	FITTING, 1/8" FPT COUPLING	Added 4/08 for High-Performance block/roller guide configurations to improve hose routing.	1
6	P02764	FITTING, 1/8" DRY SEAL NIPPLE		1

4.6 Control Box Assembly

LMS-A Rev A.00+
LMS-RA Rev. E.00+
LMS-LX Rev A.00+

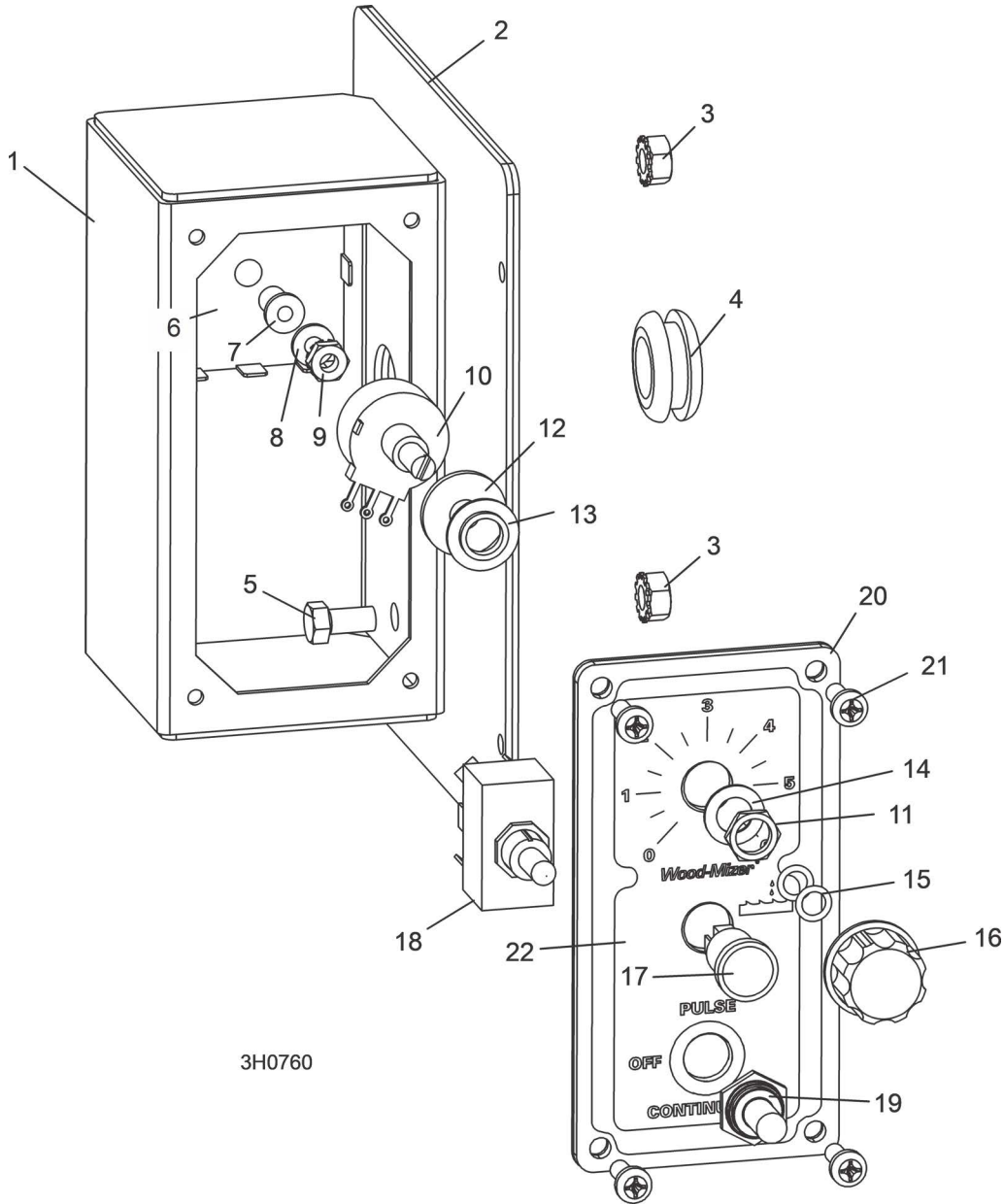

REF	PART #	DESCRIPTION	COMMENTS	QTY.
	025017	CONTROL ASSEMBLY, LMS REPLACEMENT	Replacement Kit 025017 is the service kit for 033480 Control Assembly	1
1	033481	Control Box Weldment, LubeMizer		1
2	033495	Panel Weldment, Side	Available in assemblies only.	1
	015274	Gasket, Side Panel	Available in assemblies only.	1
3	F05010-9	Nut, 1/4-20 Self Locking		2
4	033475	Grommet, 5/8" ID x 3/16" Rubber		1
5	F05005-15	Bolt, 1/4-20 x 1/2" Hex Head		2

4 Replacement Parts

Control Box Assembly

REF	PART #	DESCRIPTION	COMMENTS	QTY.
6	024530	Timer, Repeat Cycle 12VDC 1A .2 - 60 sec		1
7	024409	Insulator, Nylon Screw #10 1/2"		1
8	F05011-41	Washer, #8 SAE Flat		1
9	F05010-14	Nut, #10-24 Self Locking		1
	024590	Potentiometer Assembly, 500K 2W 10% CP Panel Mount w/Wires		1
10	N/A	Potentiometer	Available in assemblies only.	1
11	N/A	Nut	Available in assemblies only.	1
12	F05011-16	Washer, 5/16" Standard Flat		1
13	033454	Washer, 3/8" ID x 3/4" OD Nylon Shoulder		1
14	033444	Washer, 3/8" ID x 5/8" OD x .032 Thick Nylon		1
15	033476	O-Ring, 7/32" ID #009		2
16	033478	Knob, 1/4" ID Fluted Round Plastic		1
17	E20483	Light, Green 12V .187 Tabs		1
18	024588	Switch, 15A Toggle		1
19	024589	Boot, Toggle Switch Sealing		1
20	033487	Plate, Control Panel Lube	Available in assemblies only.	1
	033488	Gasket, LubeMizer	Available in assemblies only.	1
21	F05015-17	Bolt, #10-24 x 1/2" Pan Head		4
22	033498	Decal, LubeMilzer Control Panel	Available in assemblies only.	1
	024555	Fuseholder, 3-20A ATC In-Line w/Cover		2
	024150-2	Fuse, 2A ATO Blade Lt Grey		1
	024150-4	Fuse, 4A ATO Blade Pink		1

SECTION 5 ELECTRICAL INFORMATION

5.1 Electrical Components

Component	Wood-Mizer Part No.	Description
D1	024123 ¹	Diode Assembly, Inductive Kick Protection
F1	024555	Fuseholder, In-Line 3-20 Amp ATC w/Cover
	024150-2	Fuse, 2 Amp ATO Blade Light Grey
F2	024555	Fuseholder, In-Line 3-20 Amp ATC w/Cover
	024150-4	Fuse, 4 Amp ATO Blade Pink
L1	E20483	Light, Green 12V .187 Tabs
P1	033492	Pump Assembly, LubeMizer (Includes D1)
R1	024591	Resistor Assembly, 47K Yellow Lube Timer
SW1	024588	Switch, 15 Amp Toggle
T1	024530	Timer, Repeat Cycle 12VDC 1A .2-60 Seconds
VR1	024590	Potentiometer Assembly, 500K 2W 10% CP Panel Mount

¹ Added Rev. C.00 to protect power feed control circuit. Use kit 050805 to retrofit earlier revisions.

5.2 Electrical Wiring Diagram (Control Circuit)

Rev. E.00+

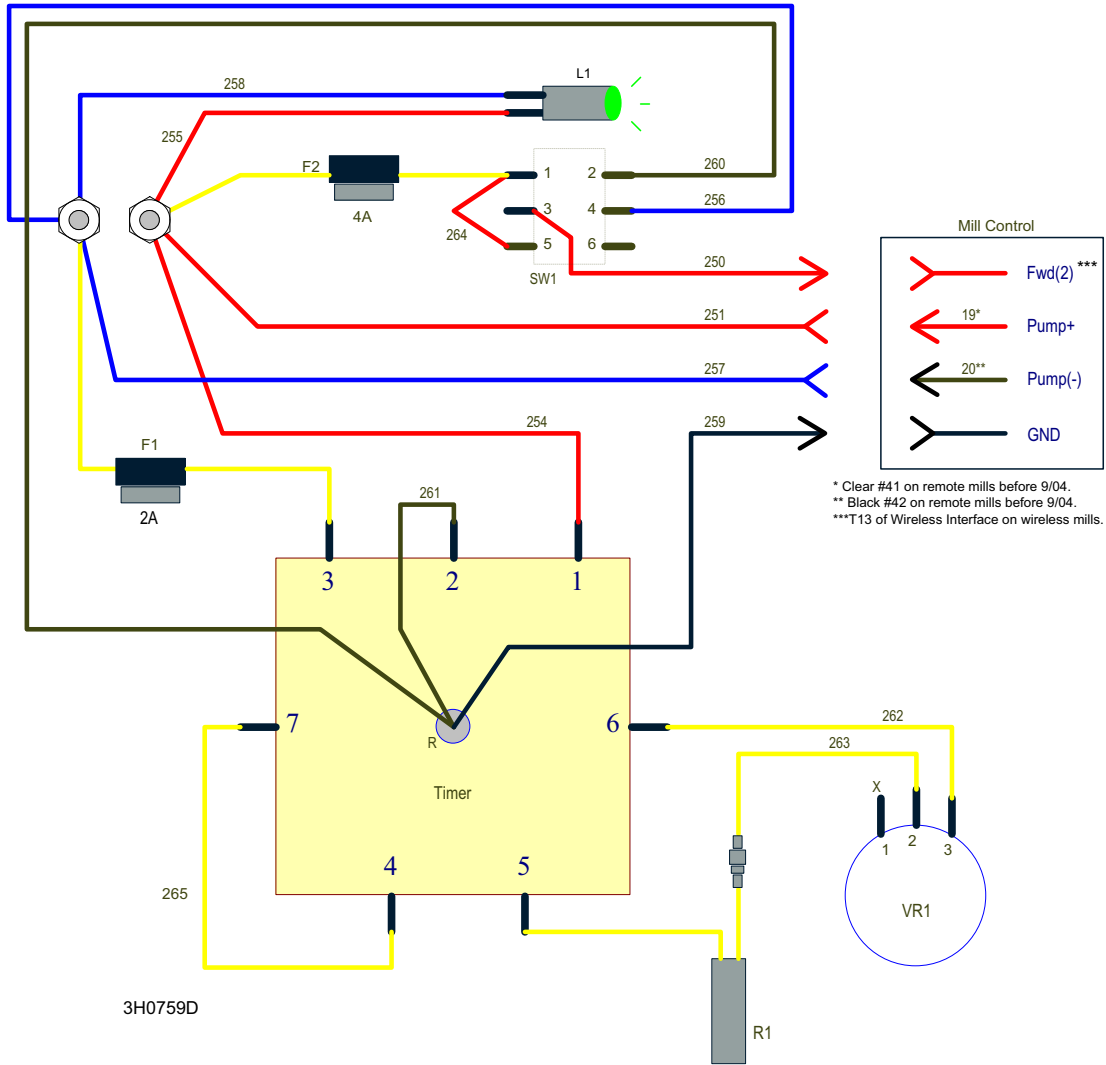

FIG. 5-1

Rev. A.00 - D.01

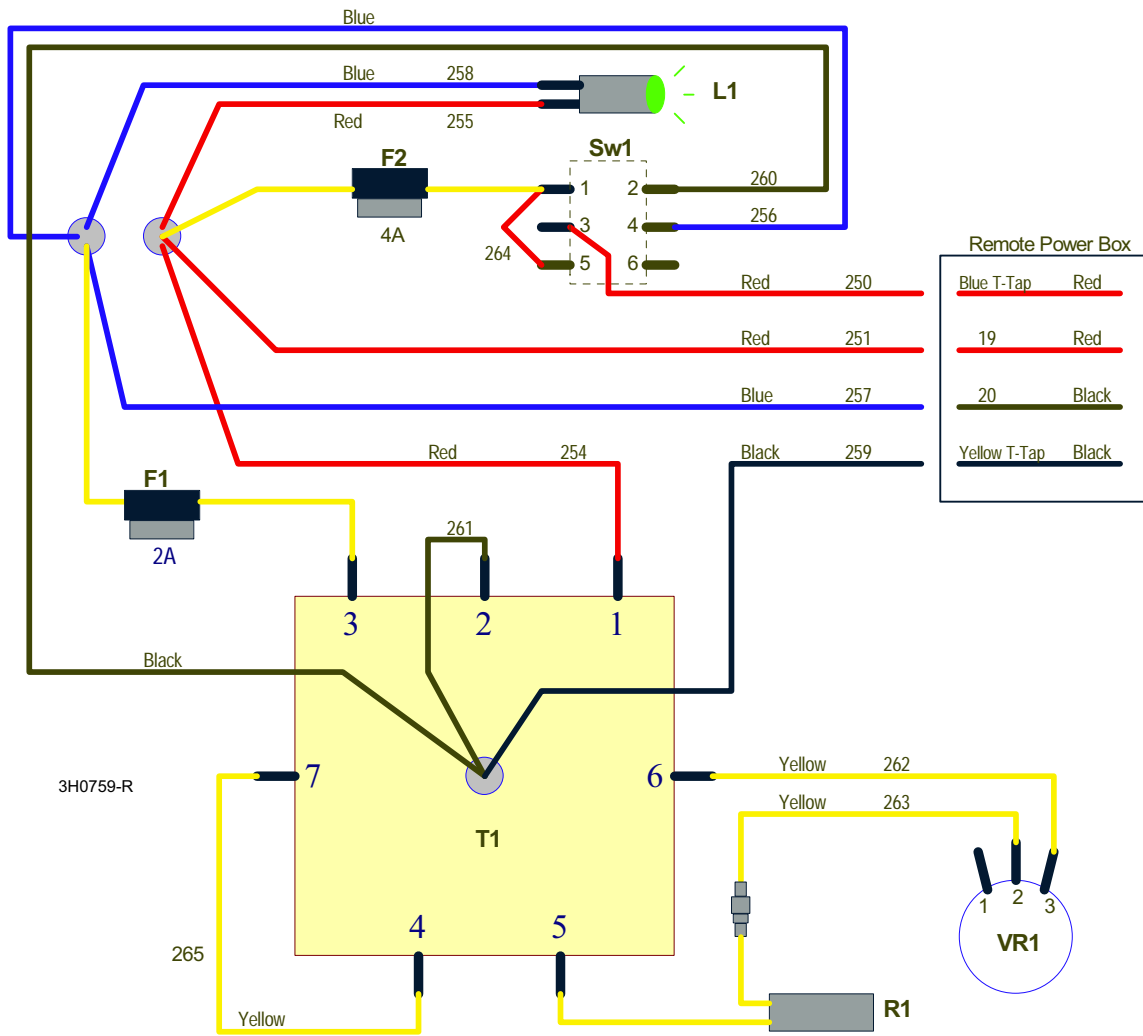

FIG. 5-2