

Debarker Option

Safety, Installation, Operation, Maintenance & Parts Manual

MKII for DC LT60/70 rev. A.00 - B.03



Safety is our #1 concern! Read and understand all safety information and instructions before operating, setting up or maintaining this machine.

January 2002

Form #1060

California
Proposition 65 Warning



WARNING: Breathing gas/diesel engine exhaust exposes you to chemicals known to the State of California to cause cancer and birth defects or other reproductive harm.

- Always start and operate the engine in a well-ventilated area.
- If in an enclosed area, vent the exhaust to the outside.
- Do not modify or tamper with the exhaust system.
- Do not idle the engine except as necessary.

For more information go to **www.P65warnings.ca.gov**.



WARNING: Drilling, sawing, sanding or machining wood products can expose you to wood dust, a substance known to the State of California to cause cancer. Avoid inhaling wood dust or use a dust mask or other safeguards for personal protection.

For more information go to **www.P65Warnings.ca.gov/wood**.

©2019

Printed in the United States of America, all rights reserved. No part of this manual may be reproduced in any form by any photographic, electronic, mechanical or other means or used in any information storage and retrieval system without written permission from

Wood-Mizer
8180 West 10th Street
Indianapolis, Indiana 46214

Table of Contents

Section-Page

SECTION 1	SAFETY	1-1
1.1	Installation and Maintenance.....	1-1
1.2	Operation and Towing.....	1-2
SECTION 2	DEBARKER INSTALLATION	2-1
2.1	Debarker Installation	2-2
2.2	Harness Installation	2-6
2.3	Control Component Installation (Non-Remote Mills)	2-9
2.4	Control Component Installation (Remote Mills).....	2-16
SECTION 3	ALIGNMENT	3-1
SECTION 4	OPERATION AND MAINTENANCE	4-1
4.1	Locking Pin Operation	4-1
4.2	Control Overview	4-2
4.3	Operation	4-4
4.4	Maintenance	4-6
4.5	Troubleshooting.....	4-8
SECTION 5	ELECTRICAL INFORMATION	5-1
5.1	Electrical Symbol Diagram (Non-Remote).....	5-1
5.2	Electrical Symbol Diagram (Remote)	5-2
5.3	Electrical Component List.....	5-3
5.4	Electrical Wiring Diagram (non-Remote Sawmills)	5-4
	<i>LT60HD/70HDRev. B3.00+</i>	<i>5-4</i>
	<i>LT60HD/70HDRev. A4.00 - B2.00</i>	<i>5-5</i>
	<i>LT60HD/70HDRev. A1.00 - A3.03</i>	<i>5-6</i>
5.5	Electrical Wiring Diagram (Remote Sawmills)	5-7
	<i>LT70HD RemoteRev. B3.00+</i>	<i>5-7</i>
	<i>LT70HD RemoteRev. A4.00 - B2.00</i>	<i>5-9</i>
	<i>LT70HD RemoteRev. A1.00 - A3.03</i>	<i>5-11</i>
5.6	Electrical Wiring Diagram (DC Wireless Sawmills)	5-13
	<i>LT70HD DC WirelessRev. A9.00+.....</i>	<i>5-13</i>
SECTION 6	DEBARKER PARTS	6-1
6.1	Mechanical Assembly	6-1
6.2	Actuator Assembly	6-1
	<i>Rev. A.00</i>	<i>6-1</i>
6.3	Frame Assembly.....	6-2
	<i>Rev. B.00+</i>	<i>6-2</i>
6.4	Frame Assembly.....	6-4
	<i>Rev. A.00</i>	<i>6-4</i>

Table of Contents

Section-Page

6.5	In/Out Motor Drive Assembly.....	6-6
	<i>Rev. B.00+</i>	<i>6-6</i>
6.6	Blade Motor Assembly.....	6-8
6.7	Blade Housing Assembly	6-10
6.8	Spring Rod Assembly.....	6-12
	<i>Rev. B.00+</i>	<i>6-12</i>
6.9	Debarker Control Assembly.....	6-14

INDEX

I

SECTION 1 SAFETY



This symbol calls your attention to instructions concerning your personal safety. Be sure to observe and follow these instructions. This symbol accompanies a signal word. The word **DANGER** indicates an imminently hazardous situation which, if not avoided, will result in death or serious injury. **WARNING** suggests a potentially hazardous situation which, if not avoided, could result in death or serious injury. **CAUTION** refers to potentially hazardous situations which, if not avoided, may result in minor or moderate injury to persons or equipment. Read all safety instructions before operating this equipment and observe all safety warnings!

1.1 Installation and Maintenance



DANGER! On electric mills, hazardous voltage inside the disconnect box, starter box, and at the electric motor can cause shock, burns, or death. Disconnect and lock out power supply before performing debarker installation! Follow all applicable electrical codes.

DANGER! Make sure all electrical installation, service and/or maintenance work is performed by a qualified electrician and is in accordance with applicable electrical codes. Failure to do so will result in serious injury or death.

DANGER! Before performing any service to this equipment, turn the key to the OFF position, remove the key, and disconnect the sawmill battery ground terminal. Failure to do so will result in serious injury or death.



WARNING! Before replacing the debarker blade, move the sawmill blade guide arm in front of the sawmill blade to cover the blade teeth. Failure to do so may result in serious injury or death.

1.2 Operation and Towing



DANGER! Make sure all guards and covers are in place and secured before operating the debarker option. Failure to do so may result in serious injury.

DANGER! Keep all persons out of the path of moving equipment when operating the debarker. Failure to do so will result in serious injury.

DANGER! Always remove the key from the control panel before preparing the debarker for towing. Failure to do so may result in serious injury.



WARNING! Debarker is ON when warning light. DO NOT disconnect the warning light. Doing so may result in serious injury.

WARNING! If the debarker continues to run with the key switch in the OFF position, remove the negative battery terminal from the battery post.

DO NOT continue to operate the mill if the main key switch does not control debarker operation. Doing so could result in serious injury. Call Wood-Mizer customer service for more information.

SECTION 2 DEBARKER INSTALLATION



DANGER! On electric mills, hazardous voltage inside the disconnect box, starter box, and at the electric motor can cause shock, burns, or death. Disconnect and lock out power supply before performing debarker installation! Follow all applicable electrical codes.

DANGER! Before performing any service to this equipment, turn the key to the OFF (0) position, remove the key, and disconnect the sawmill battery ground terminal. Failure to do so will result in serious injury or death.



CAUTION! Due to various design changes and past retrofits and options, you should very carefully look your mill over to determine Debarker compatibility before beginning Debarker installation.

2.1 Debarker Installation



DANGER! Always disengage the blade and shut off the sawmill engine before installing the debarker. Failure to do so will result in serious injury.

IMPORTANT! Sawmills are equipped with pre-drilled Debarker mounting holes. **Verify hole locations before beginning Debarker installation. Proper hole location is imperative for safe and effective Debarker operation.**

See Figure 2-1. The debarker wiring is pre-routed and secured at the debarker mounting location with a guard. Remove the guard and route the wiring through the grommet in the saw head. Note the location of the two debarker mounting holes.

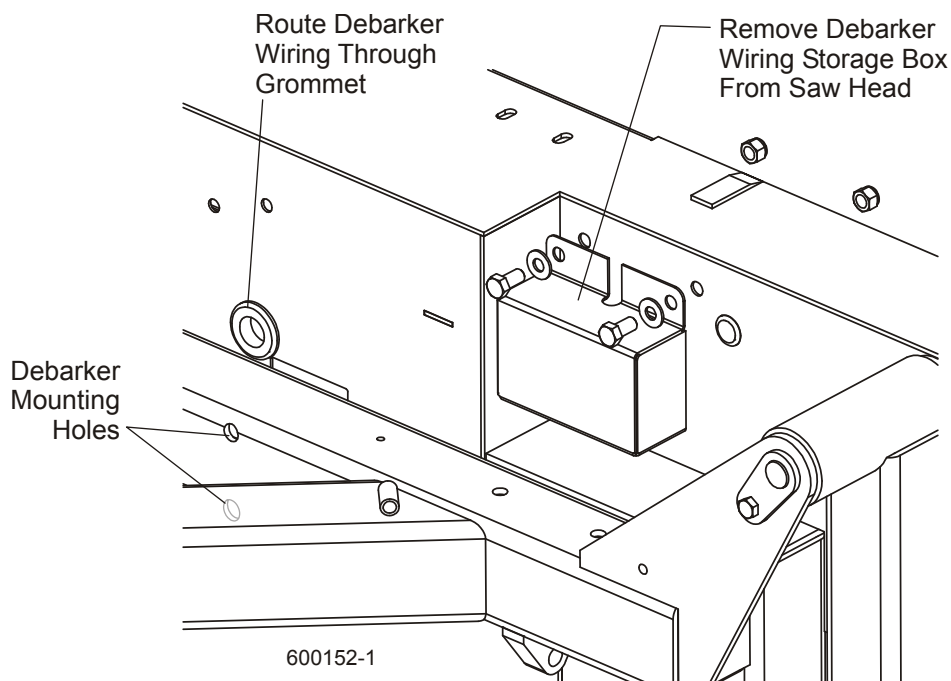

FIG. 2-1

1. Assemble the debarker to the sawmill saw head. Align the mounting block holes and the two debarker mounting holes in the saw head. Use the provided 1/2-13 x 4" hex head bolts and 1/2" split lock washers to secure in place. Make sure the debarker is square to the saw head before tightening.

2. Rev. A.00 Only: Install the actuator assembly to the saw head.

NOTE! The debarker actuator assembly may be replaced with a new gear motor operation assembly to improve performance and durability. Use kit 036304 to upgrade Rev. A.00 debarkers.

Open the left and right blade housing covers. **NOTE:** Make sure the blade is not running and the sawmill engine is shut off before opening the blade housing covers.

Open the middle blade housing cover. Remove the pre-installed bolt and two lock nuts from the debarker actuator assembly.

Align the debarker actuator mounting hole and the hole in the saw head. Insert the bolt through the debarker actuator mounting hole. Use the two lock nuts previously removed to secure the debarker actuator in place. Tighten the mounting bolt and the two lock nuts.

See Figure 2-2.

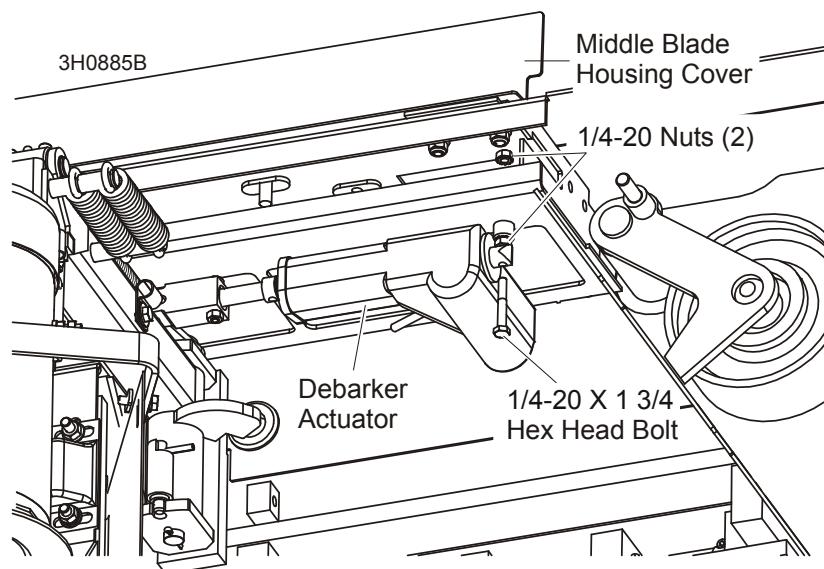

FIG. 2-2

3. Rev. B.00+ Only: Install the spring arm assembly to the saw head.

Open the left blade housing cover. **NOTE:** Make sure the blade is not running and the sawmill engine is shut off before opening the blade housing covers.

Align the debarker spring arm bracket holes and the holes in the saw head. Insert the two

2

Debarker Installation

Debarker Installation

3/8-16 x 1" hex head bolts through the saw head holes and spring arm bracket holes. Use the two flat washers and lock nuts to secure the spring arm in place.

4. Assemble the debarker cutting head to the mount plate on the frame.

Use the four provided 5/16-18 x 3/4" bolts and 5/16" split lock washers to mount the cutting head to the debarker frame. Use the lower set of four holes in the head mounting plate. The upper set of holes are provided in the event the cutting head needs to be adjusted further down than the slotted motor mount holes will allow.

See Figure 2-3.

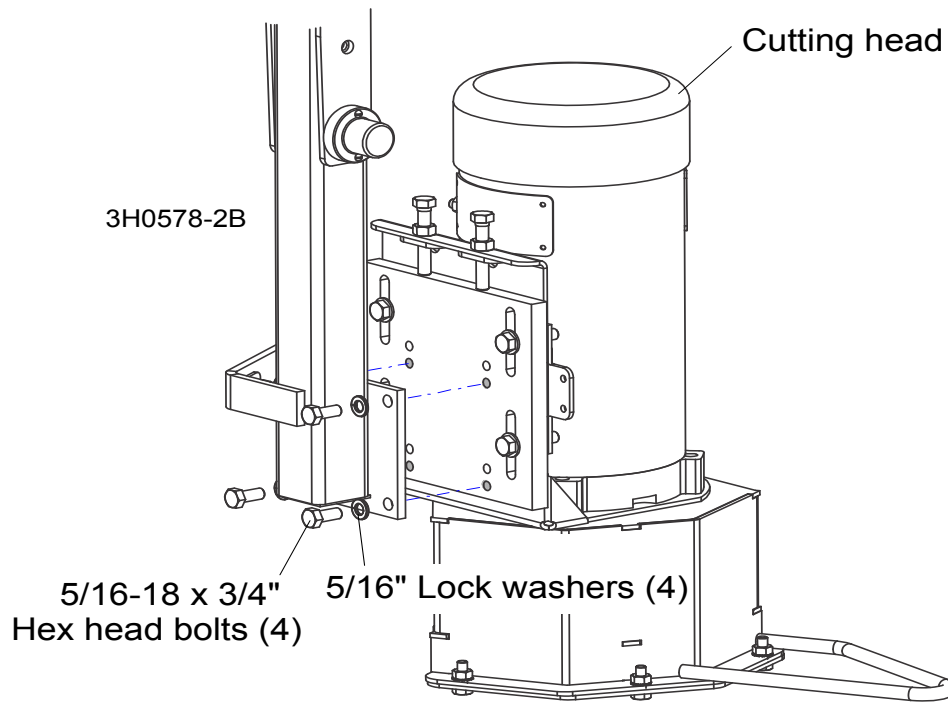

FIG. 2-3

- 5. Install the blade guard bracket and flexible debris guard to the debarker head with two 1/4" flat washers, lock washers, and 1/4-20 x 1" hex head bolts. Be sure the bottom of the debris guard is even with the bottom of the debarker blade.

See Figure 2-4.

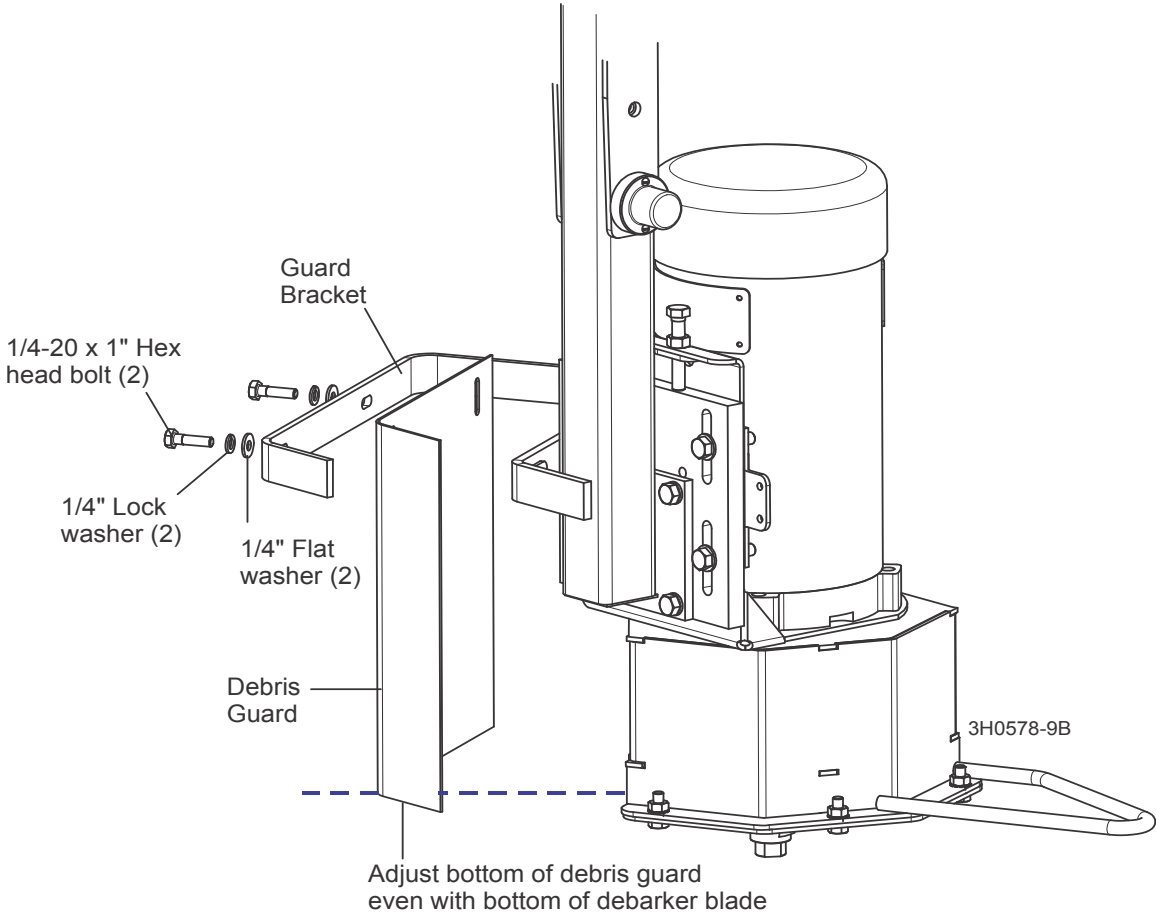

FIG. 2-4

2 Debarker Installation

Harness Installation

2.2 Harness Installation

DANGER! Before performing any service to this equipment, turn the key to the OFF (0) position, remove the key, and disconnect the sawmill battery ground terminal. Failure to do so will result in serious injury or death.



IMPORTANT! Avoid pinch and pivot points, unnecessary wire bending and open spaces where the wire could get caught by a log, etc. If you have any questions, call Wood-Mizer customer service.

1. Route the harnesses through the saw head frame hole as shown. Continue routing the long blade motor wire harness (large wires/ring terminals) along the debarker frame through the three cable clamps.

See Figure 2-5.

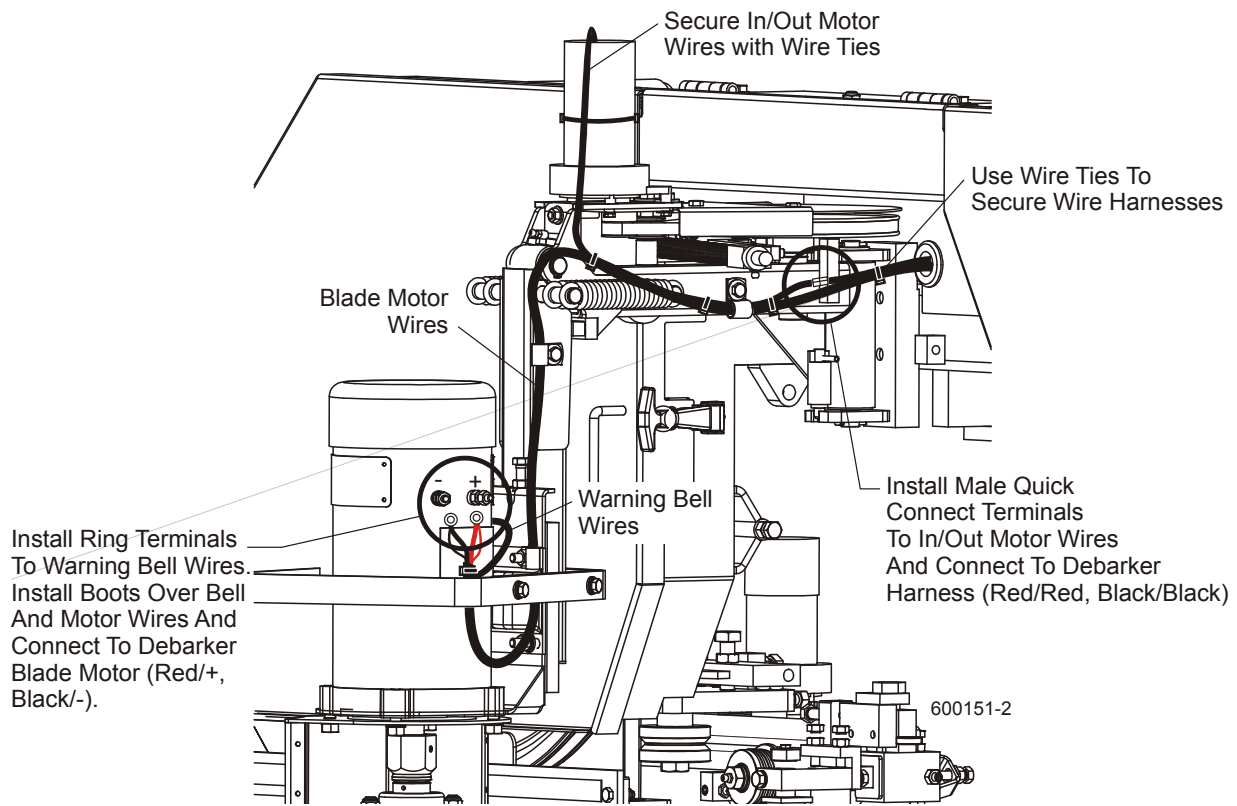

FIG. 2-5

- 2. Cut the conduit of the in/out motor wire harness to expose the quick connect terminals. Remove the rubber cap from the in/out motor and install the removed conduit around the in/out motor wires. Route the wires down the side of the in/out motor, through the cable clamp, to the quick connects. Be sure to leave slack in the harness to avoid kinking and bending as the debarker moves in and out. Replace the motor cap and secure the harness to the in/out motor by connecting two wire ties together and wrapping around the motor.
- 3. Cut the in/out motor wires and install the provided male quick connect terminals to each wire. Connect the black in/out motor wire to the black harness wire and the red in/out motor wire to the red harness wire. Pull the conduit over the terminal connection and secure the harness to the blade motor harness with wire ties.
- 4. Install the provided short piece of conduit to the warning bell wires. Route the harness behind the debarker blade motor, along the blade motor harness.
- 5. Secure the warning bell wires to the motor harness with a wire tie approximately 3" from the motor terminals as shown.

See Figure 2-6.

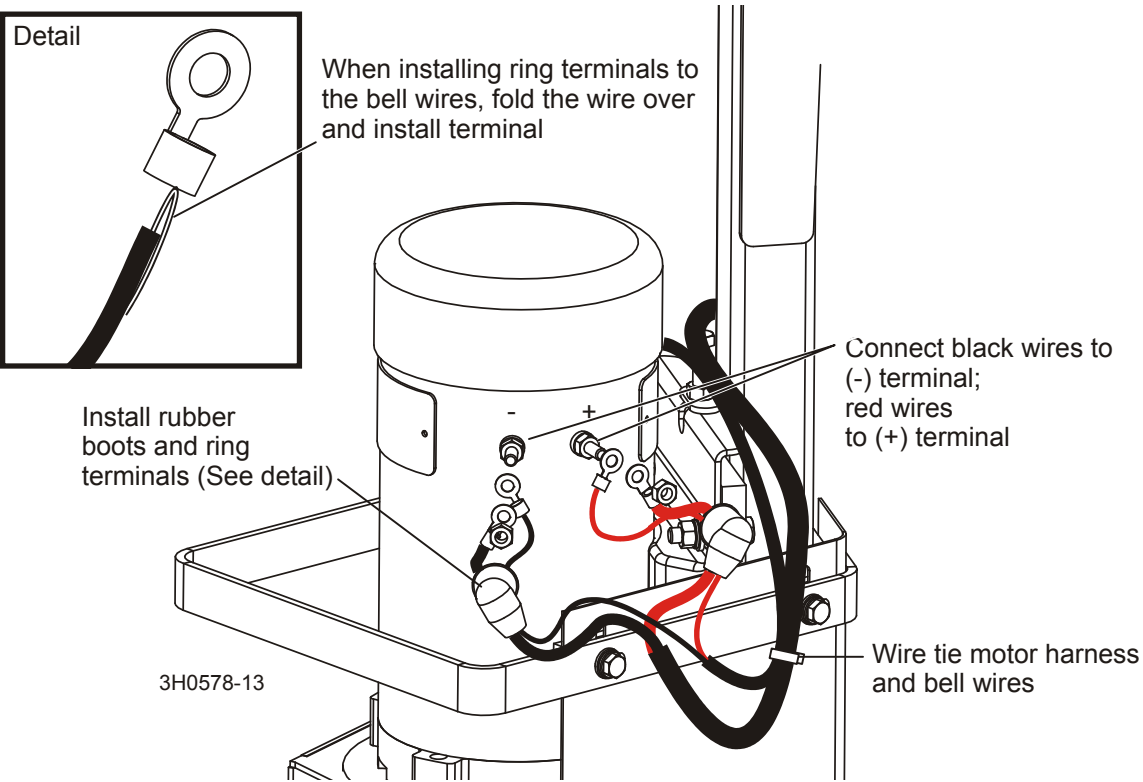

FIG. 2-6

2

Debarker Installation

Harness Installation

6. Remove the top nuts from each of the motor terminals.
7. Route the black motor wires from the motor and bell harnesses through one of the provided rubber boots. Strip the end of the black warning bell wire and install a 1/4" 14-16 gauge ring terminal. To install the 14-16 gauge ring terminal, fold the stripped end of the wire over the insulation, install the ring terminal and crimp in place.
8. Connect the black motor and bell wires to the negative (-) motor terminal. Replace the terminal nut to secure the wires.



IMPORTANT! Make sure that the ring terminals do not touch the motor body.

9. Route the red motor and bell wires through one of the provided rubber boots. Strip the end of the red warning bell wire and install a 1/4" 14-16 gauge ring terminal. To install the 14-16 gauge ring terminal, fold the stripped end of the wire over the insulation, install the ring terminal and crimp in place.
10. Connect the red motor and bell wires to the positive (+) motor terminal. Replace the terminal nut to secure the wires.



IMPORTANT! Make sure that the ring terminals do not touch the motor body.

11. Slide the rubber boots over the motor terminal posts to protect the connections.

2.3 Control Component Installation (Non-Remote Mills)



DANGER! On electric mills, hazardous voltage inside the disconnect box, starter box, and at the electric motor can cause shock, burns, or death. Disconnect and lock out power! Follow all applicable electrical codes.

DANGER! Before performing any service to this equipment, turn the key to the OFF (0) position, remove the key, and disconnect the sawmill battery ground terminal. Failure to do so will result in serious injury or death.

[See Section 2.4](#) if assembling the Debarker option to a sawmill equipped with the remote operation option. [See SECTION 5](#) for the appropriate wiring diagram to aid in installation.

1. Remove the side, front and rear panels (leave wire connections) from the control box.
2. Locate the solenoid mounting studs in the control box. Place the solenoid on the mounting studs and place the diode assembly ring terminal over one of the studs. Use the two 1/4-20 self-locking nuts provided to secure in place.

See Figure 2-7.

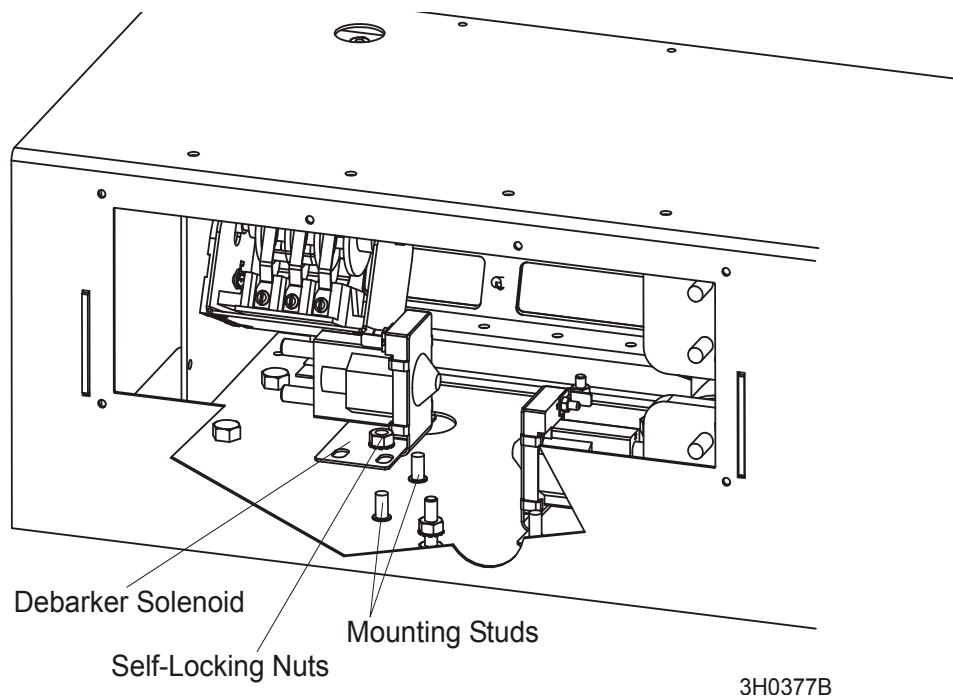

FIG. 2-7

2

Debarker Installation

Control Component Installation (Non-Remote Mills)

3. Remove the two small bolts and nuts and the one large bolt and nut from the back of the control box.
4. Locate the bundle of wires on the floor of the sawmill control box. Make sure the large black #24 wire is connected to the rear ground stud. Connect the large red #23 wire to the empty terminal on the provided 70 amp breaker. Do not overtighten this connection. Overtightening could cause component breakage.
5. Install the 70 amp breaker and rubber boot to the large hole on the back of the control box. Be sure the breaker terminals do not touch any other components or wires inside the control box.
6. Install the provided 15 amp breaker to the two small holes in the back of the control box (position the breaker so the reset tab is near the rear opening of the control box). Use the existing screws and nuts (removed earlier) to secure in place.

See Figure 2-8.

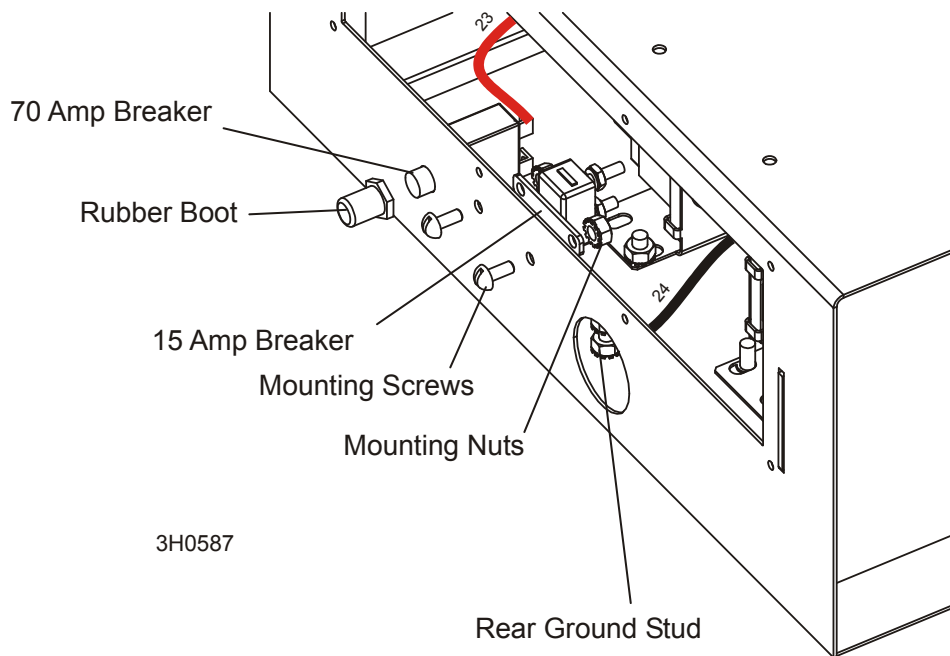

FIG. 2-8 LT60HD/70HD (BEFORE 9/04)

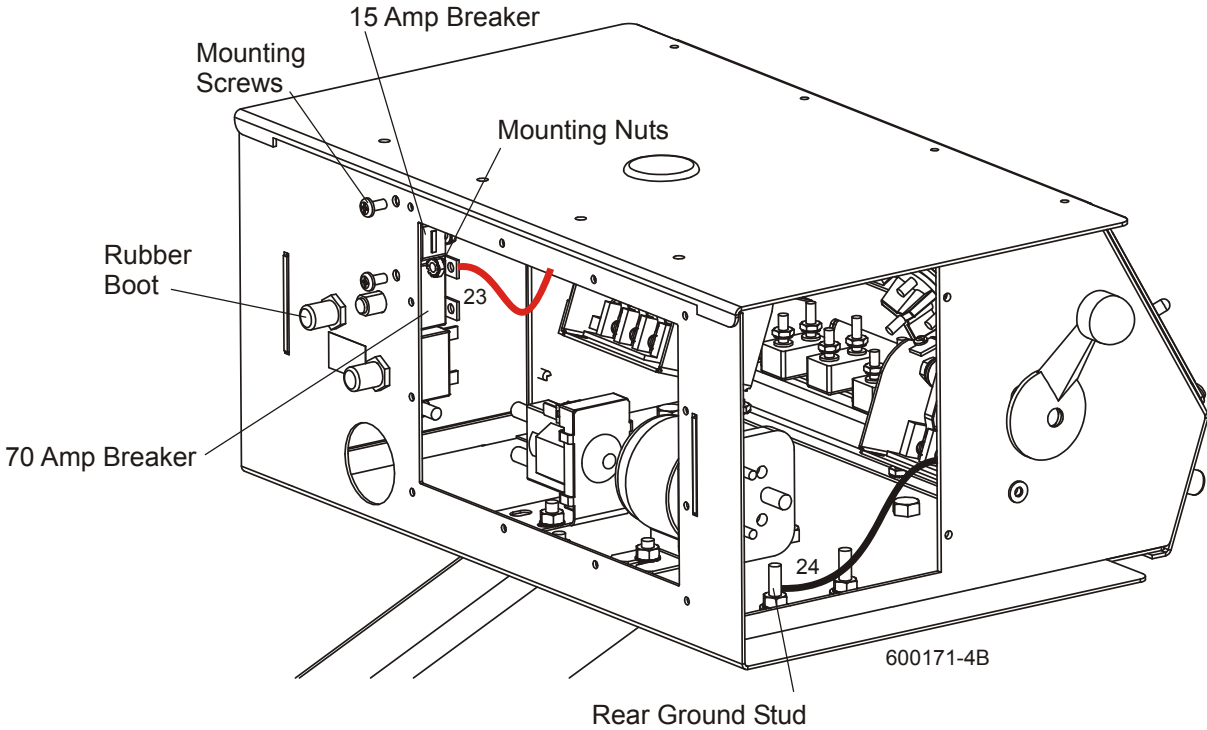

FIG. 2-8 LT60HD/70HD(AFTER 9/04)

2

Debarker Installation

Control Component Installation (Non-Remote Mills)

7. Using the back side of the front panel for a guideline, cut out holes in the front panel lexan decal for the debarker switches. Install the provided toggle switches, 1/16" nylon washers, and rubber boots in place as shown.

See Figure 2-9.

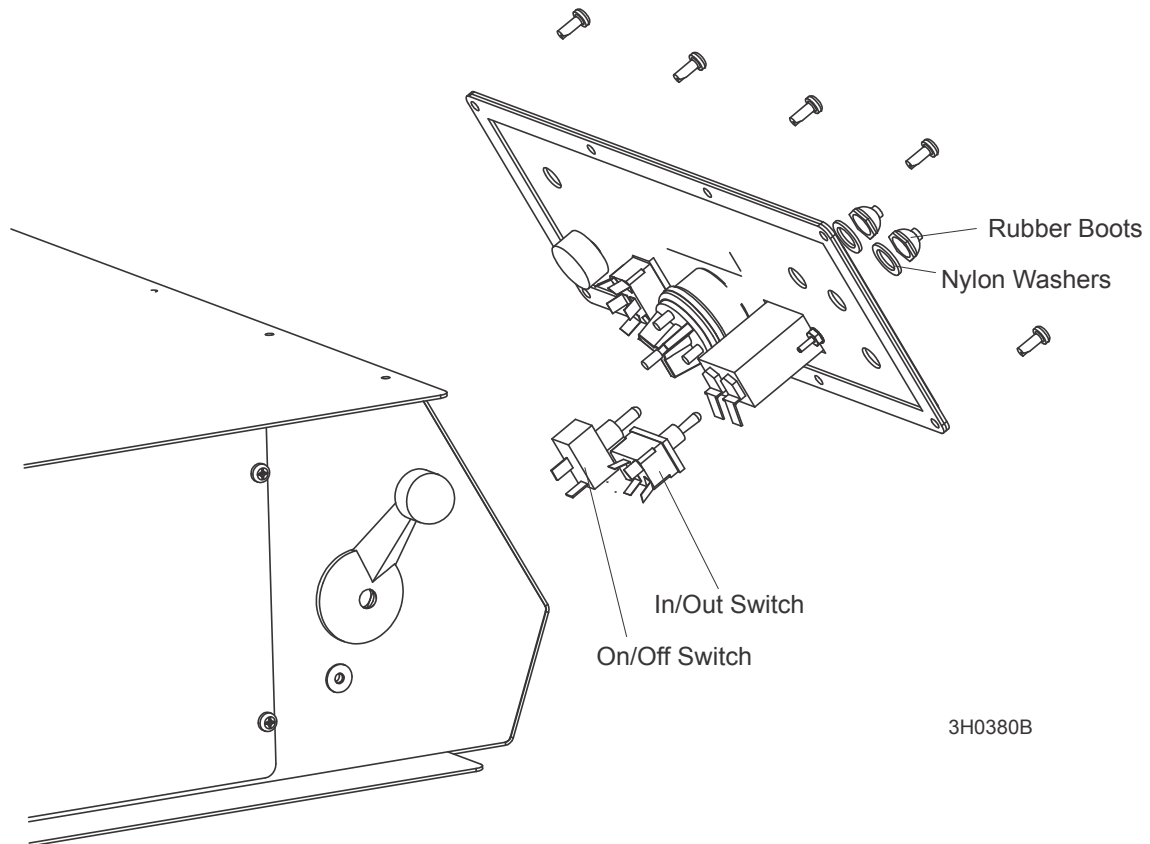

FIG. 2-9

8. Connect the red #205 wire from the 15 amp breaker to the ACC post on the key switch.
9. Make sure the red #206 wire from the 15 amp breaker to the debarker in/out switch is connected.
10. Connect the red #202 wire from the debarker solenoid to the DBKR terminal on the LED board. **NOTE:** If the control box is not equipped with the LED board, remove the red #202 wire from the debarker solenoid.
11. Make sure the red #201 wire from the small terminal on the debarker solenoid to the debarker on/off switch is connected.
12. Connect the red #203 wire from debarker solenoid to the BAT post of the key switch.
13. Make sure the red #204 wire from the bottom debarker solenoid terminal to the 70 Amp breaker is connected.

See Figure 2-10. Box housing removed for clarity. Only wires referred to above are shown.

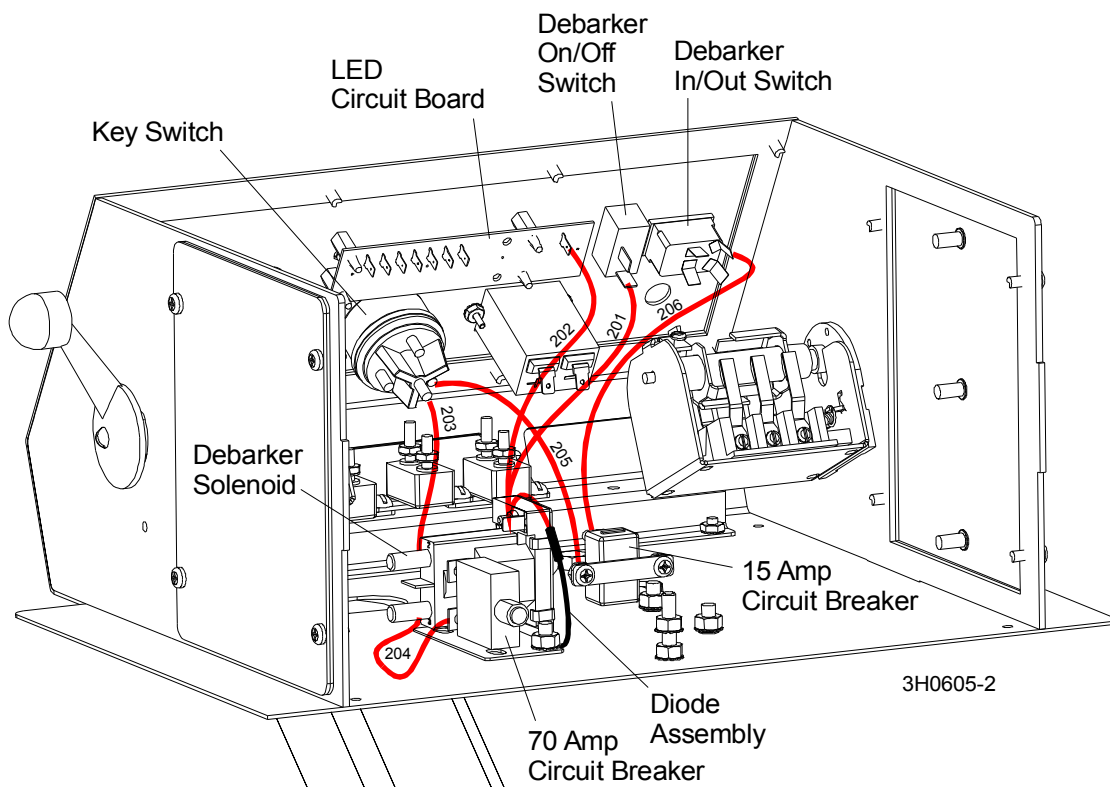

FIG. 2-10

2

Debarker Installation

Control Component Installation (Non-Remote Mills)

14. Connect the red #200 wire from the debarker on/off switch to the sawmill control:

LT60HD/70HD Wireless Models: Connect red wire #200 to the existing short red wire connected to terminal #T13 of the wireless interface control board. Use the provided #10 screw, washer and lock nut to connect the wires. Wrap the connection with the provided piece of rubber tubing and secure with a tie wrap.

LT60HD/70HD Models between 9/04 and 12/08: Connect red wire #200 to the existing short red wire connected to terminal #3 of the power feed drum switch. Use the provided #10 screw, washer and lock nut to connect the wires. Wrap the connection with the provided piece of rubber tubing and secure with a tie wrap.

All LT60HD/70HD Models before 9/04 and after 1/09: Connect red wire #200 to terminal #2 of the power feed drum switch. **NOTE:** Some sawmills are equipped with a short red wire connected to terminal #2 of the power feed drum switch. If so, connect debarker wire #200 to the end of the short wire with the provided #10 screw, washer and lock nut. Wrap the connection with the provided piece of rubber tubing and secure with a tie wrap. If no short wire exists, connect debarker wire #200 directly to power feed drum switch terminal #2.

See Figure 2-11.

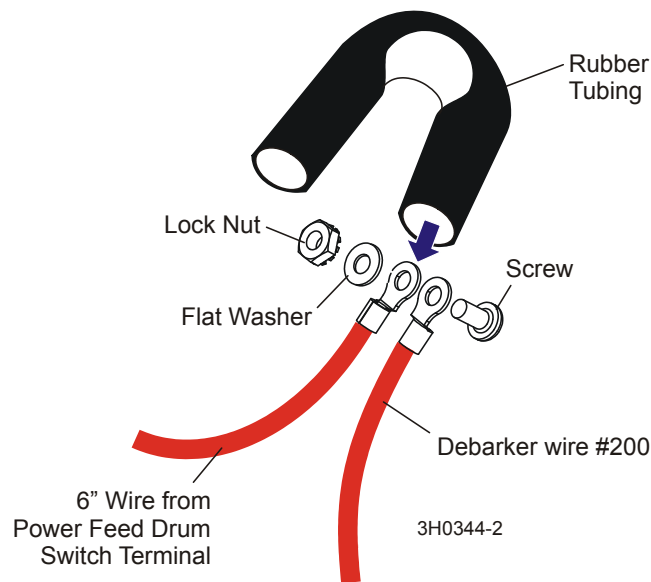

FIG. 2-11

15. Connect the black #207 wire from the debarker in/out switch to the rear ground stud.
16. Locate the bundle of wires on the floor of the sawmill control box. Make sure the debarker in/out switch is oriented horizontally as shown.
17. Connect the small red #21 wire to the debarker in/out switch bottom left terminal.
18. Connect the small black #22 wire to the debarker in/out switch top left terminal.

See Figure 2-12. Box housing removed for clarity. Only wires referred to above are shown.

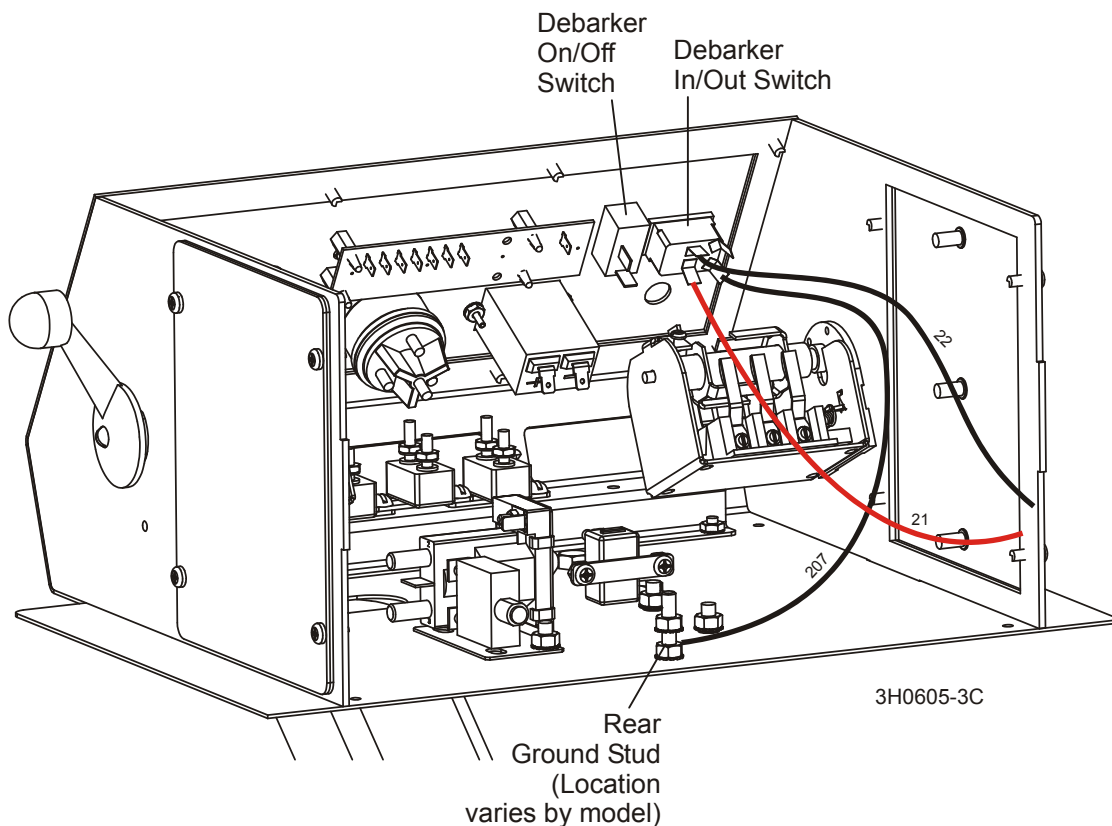

FIG. 2-12

19. Reinstall the front and rear panels, side panel, and control box top cover to the control box.

2.4 Control Component Installation (Remote Mills)



DANGER! On electric mills, hazardous voltage inside the disconnect box, starter box, and at the electric motor can cause shock, burns, or death. Disconnect and lock out power! Follow all applicable electrical codes.

DANGER! Before performing any service to this equipment, turn the key to the OFF (0) position, remove the key, and disconnect the sawmill battery ground terminal. Failure to do so will result in serious injury or death.

[See Section 2.3](#) if assembling the Debarker option to a sawmill not equipped with the remote operation option. [See SECTION 5](#) for a complete wiring diagram to aid in installation.

Remote Power Box Component Installation

See **Figure 2-13**.

1. Open the remote power junction box door.
2. Install the debarker solenoid next to the existing solenoid with the two bolts and nuts provided in the bottom of the box. Place the diode ring terminal over one of the solenoid mounting bolts before securing with the nuts.
3. Locate the large red #23 wire in the remote power box and connect it to the empty terminal on the provided 70 Amp breaker. Do not overtighten this connection. Overtightening could cause component breakage.
4. Remove the bolt and nut from the hole in the side of the remote power box and install the 70 Amp breaker and rubber boot to the hole. Be sure the breaker terminals do not touch any other components or wires inside the control box.
5. Make sure the large black #24 wire is connected to the side ground stud.
6. Locate the small red #33 wire from connector J1 terminal #16. Connect it to the small, top terminal on the debarker solenoid.
7. Connect large red #203 wire from the large bottom terminal of the debarker solenoid to the accessory solenoid:

100A Solenoid before 5/03: Connect red wire #203 to the large bottom terminal.

200A Solenoid after 5/03: Connect red wire #203 to the large terminal closest to the debarker solenoid.

Only wires referred to above are shown.

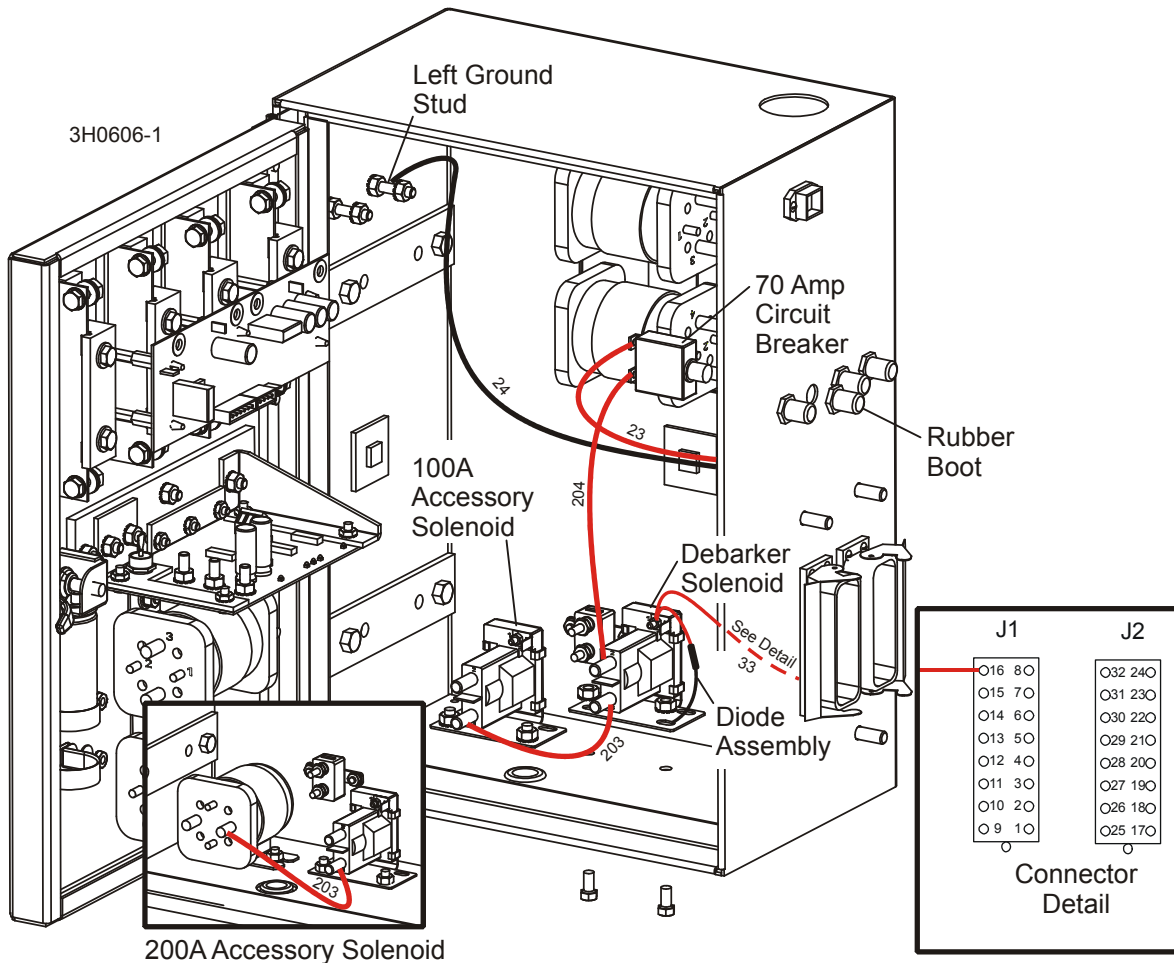

FIG. 2-13

- Close the remote power box door. Engage the door latch and tighten with a hex key to properly seal the box.

2

Debarker Installation

Control Component Installation (Remote Mills)

Sawmill Control Box Component Installation

9. Remove the rear panel from the sawmill control box (leave wire connections).
10. Remove the two small bolts and nuts from the back of the control box.
11. Install the provided 15 Amp breaker to the two small holes in the back of the control box (reset tab up). Replace the screws and nuts to secure the breaker to the back panel.

See Figure 2-14.

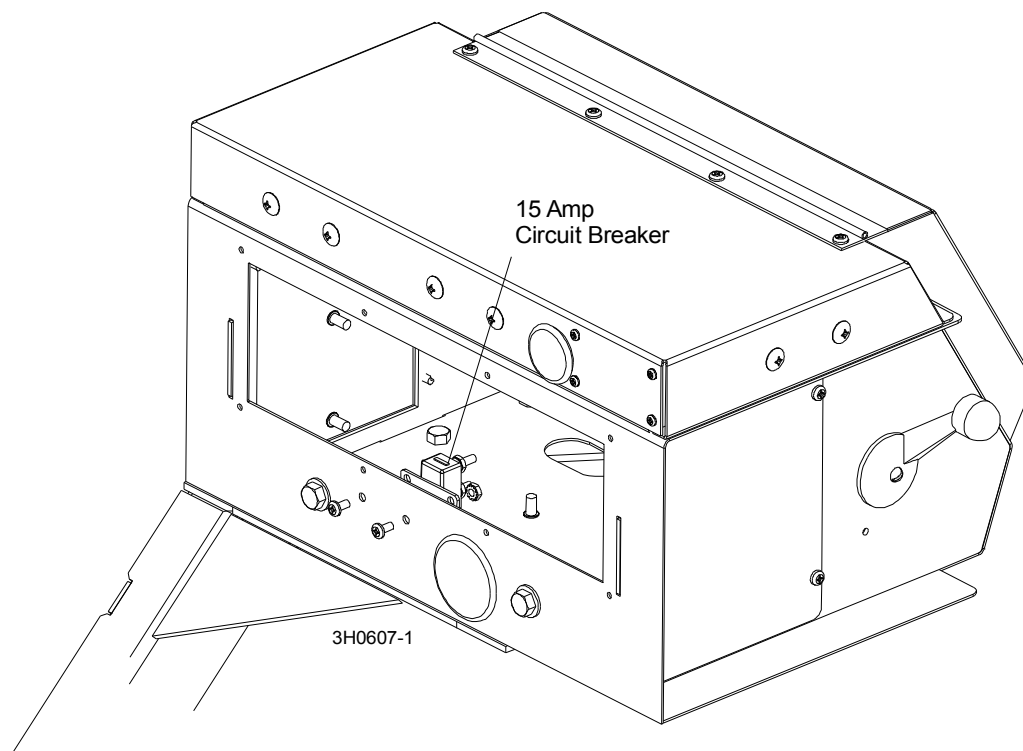

FIG. 2-14

12. Using the back side of the front panel for a guideline, cut out holes in the front panel lexan decal for the debarker switches. Install the provided toggle switches, 1/16" nylon washers, and rubber boots in place as shown.

See Figure 2-15.

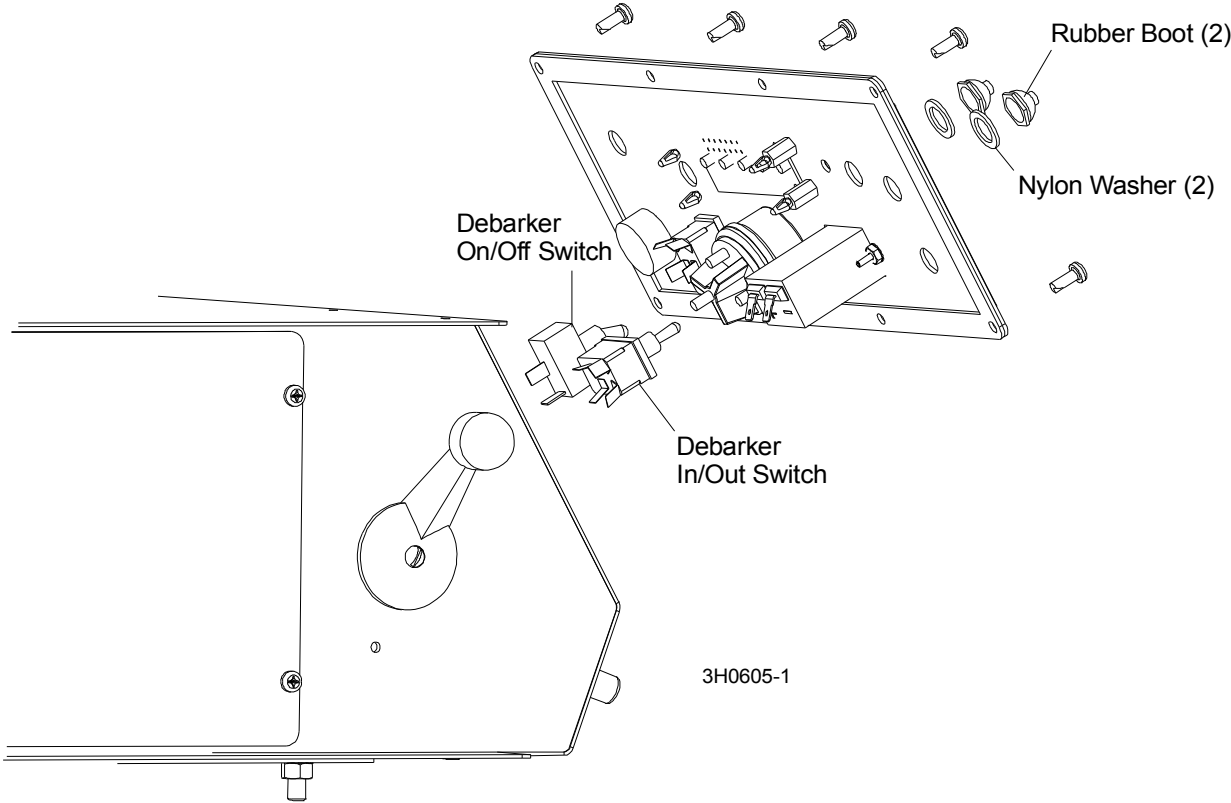

FIG. 2-15

2

Debarker Installation

Control Component Installation (Remote Mills)

13. Connect the red #205 wire from the 15 Amp breaker to the ACC post on the key switch.
14. Make sure the red #206 wire from the 15 Amp breaker to the debarker in/out switch is connected.
15. Connect the red #208 wire from the debarker on/off switch to the DBKR terminal on the LED board. **NOTE:** If the control box is not equipped with the LED board, remove the red #208 wire from the debarker on/of switch.

See Figure 2-16. Box housing removed for clarity. Only wires referred to above are shown.

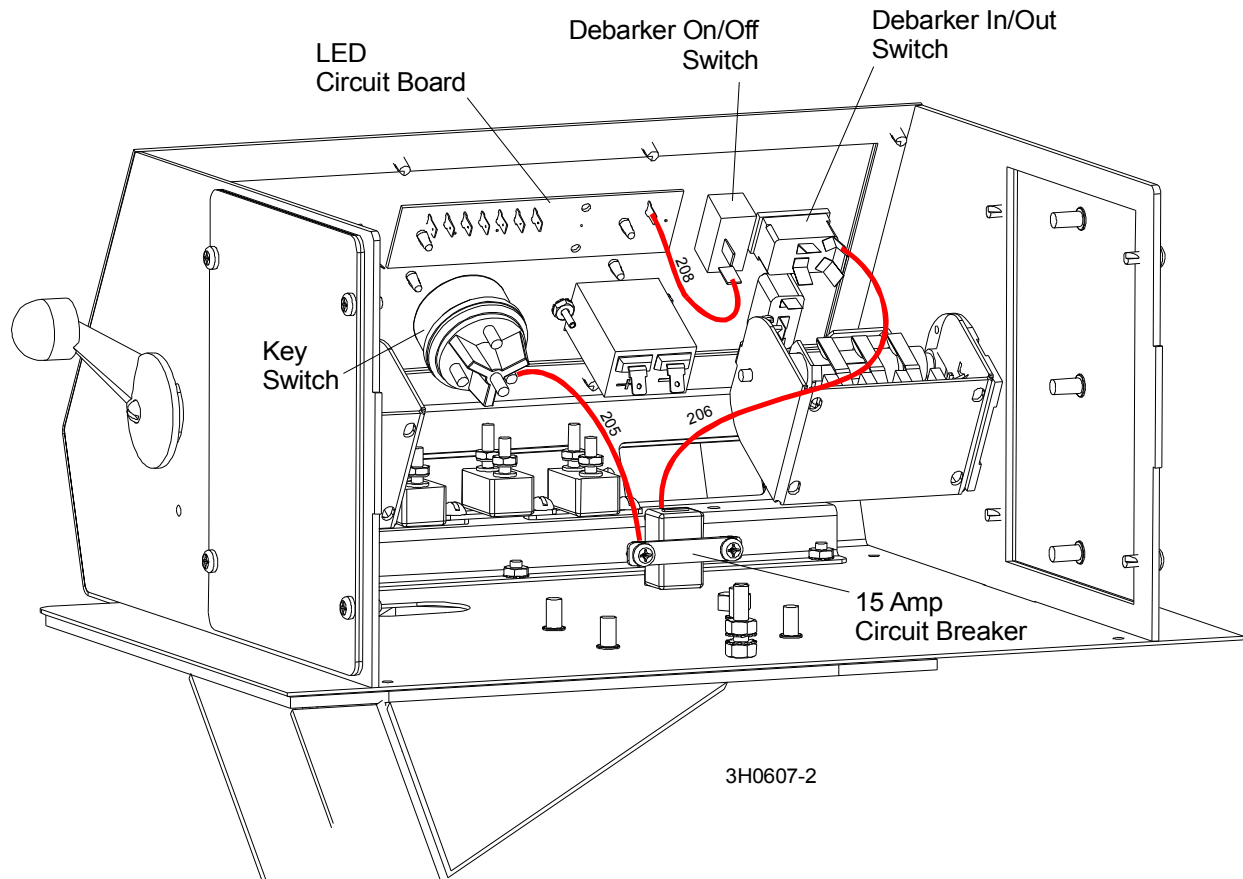

FIG. 2-16

16. Connect the red #200 wire from the debarker on/off switch to the power feed drum switch.

LT60HD/70HD Models after 9/04: Connect red wire #200 to the existing short red wire connected to terminal #3 of the power feed drum switch. Use the provided #10 screw, washer and lock nut to connect the wires. Wrap the connection with the provided piece of rubber tubing and secure with a tie wrap.

All LT60HD/70HD Models before 9/04: Connect red wire #200 to terminal #2 of the power feed drum switch. **NOTE:** Some sawmills are equipped with a short red wire connected to terminal #2 of the power feed drum switch. If so, connect debarker wire #200 to the end of the short wire with the provided #10 screw, washer and lock nut. Wrap the connection with the provided piece of rubber tubing and secure with a tie wrap. If no short wire exists, connect debarker wire #200 directly to power feed drum switch terminal #2.

See Figure 2-17.

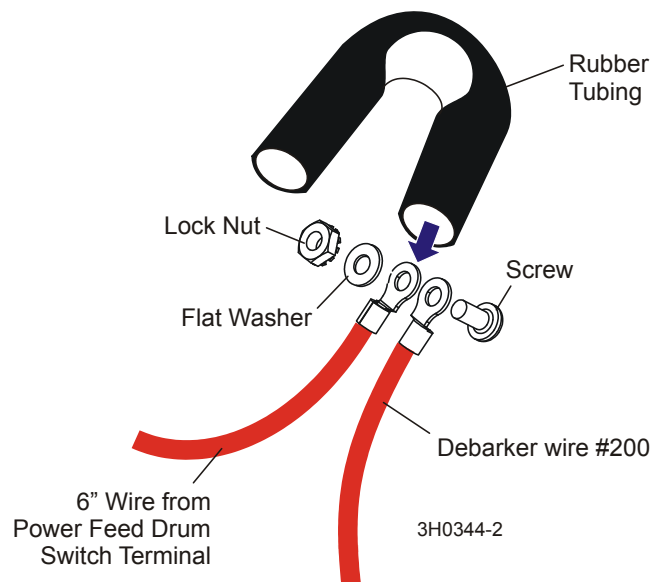

FIG. 2-17

2

Debarker Installation

Control Component Installation (Remote Mills)

17. Connect the black #207 wire from the debarker in/out switch to the rear ground stud.
18. Locate the bundle of wires on the floor of the sawmill control box. Make sure the debarker in/out switch is oriented horizontally as shown.
19. Connect the small red #21 wire to the debarker in/out switch bottom left terminal.
20. Connect the small black #22 wire to the debarker in/out switch top left terminal.
21. Connect the small red #33 wire to the male terminal extension on the debarker on/off switch bottom terminal.
22. Reinstall the control box panels.

See Figure 2-18.

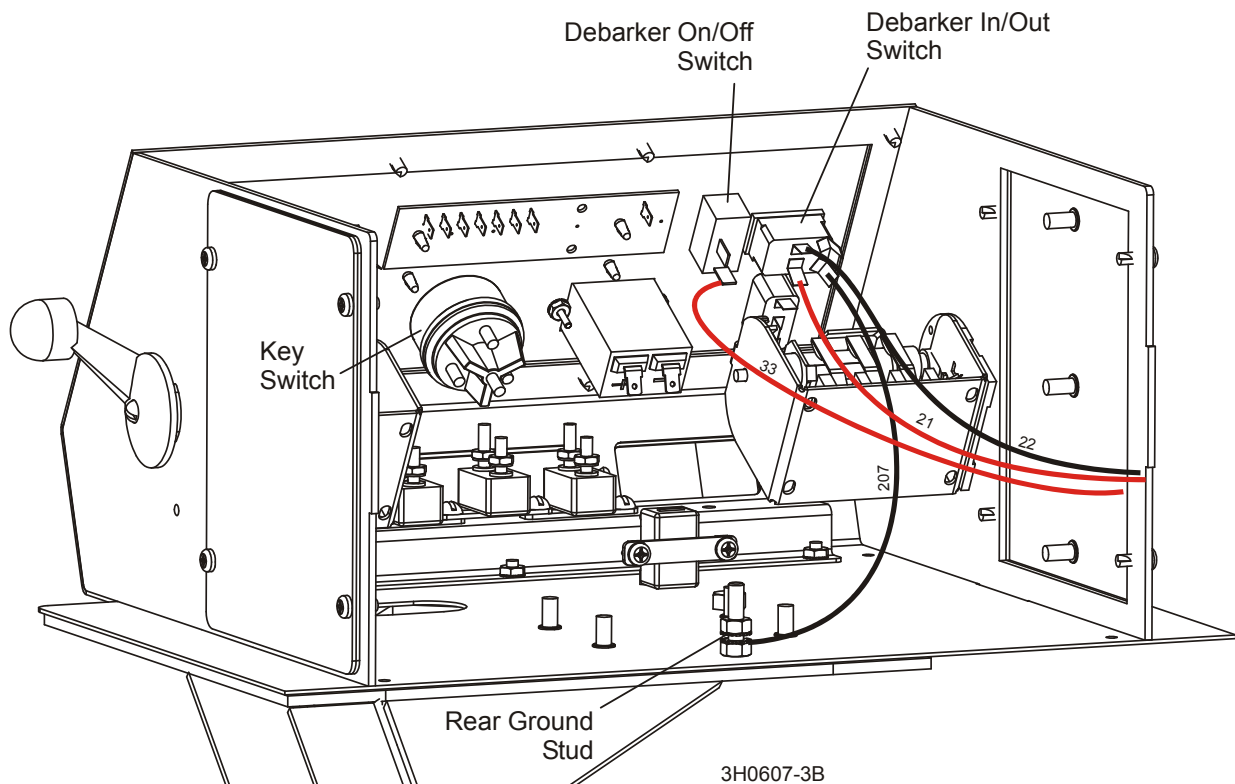

FIG. 2-18

SECTION 3 ALIGNMENT

⚠ DANGER! Before performing any service to this equipment, turn the key to the OFF (0) position and remove the key. Failure to do so will result in serious injury or death.

The debarker blade should be aligned to the sawmill blade to insure proper operation. The debarker blade should be parallel with and aligned vertically with the sawmill blade.

1. Turn the key to ACC (3) and use the debarker in/out switch to move the debarker all the way in. Turn the key to OFF (0) and remove the key. This will prevent the debarker from being turned on while performing alignment procedures.
2. Check the squareness of the debarker with the sawmill blade. Adjust the debarker mounts if necessary until the debarker is square with the sawmill blade.

Loosen the bottom debarker mounting bolt and loosen the jam nuts on the adjustment bolts. Turn the adjustment bolts as necessary until the debarker is square with the sawmill blade. Retighten the jam nuts and bottom debarker mounting bolt.

See Figure 3-1.

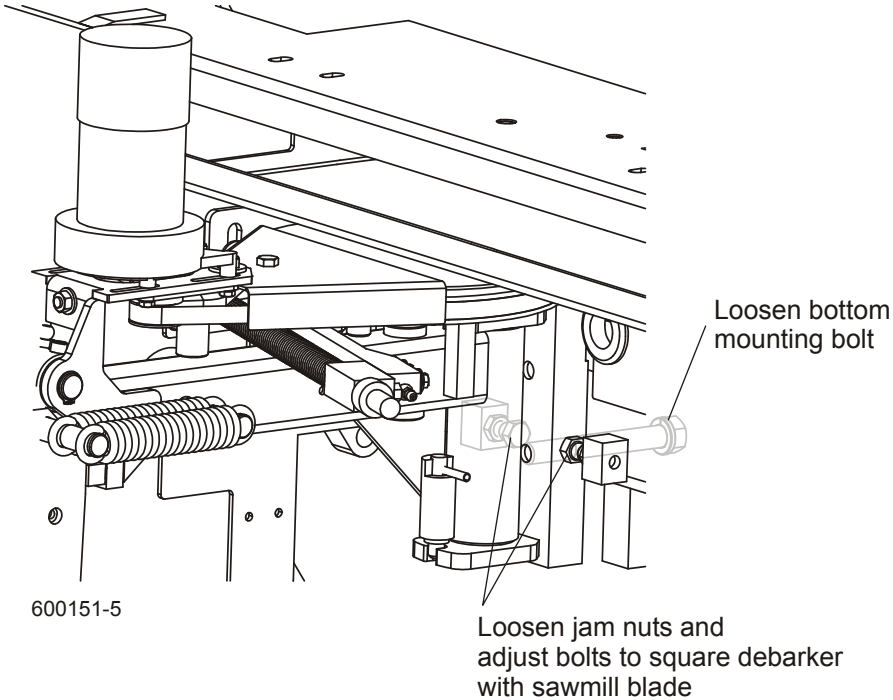

FIG. 3-1

3

Debarker Installation

- Clip the blade guide alignment tool to the sawmill blade. Make sure the tool lies flat on the blade and does not contact a tooth that could cause it to angle.

See Figure 3-2.

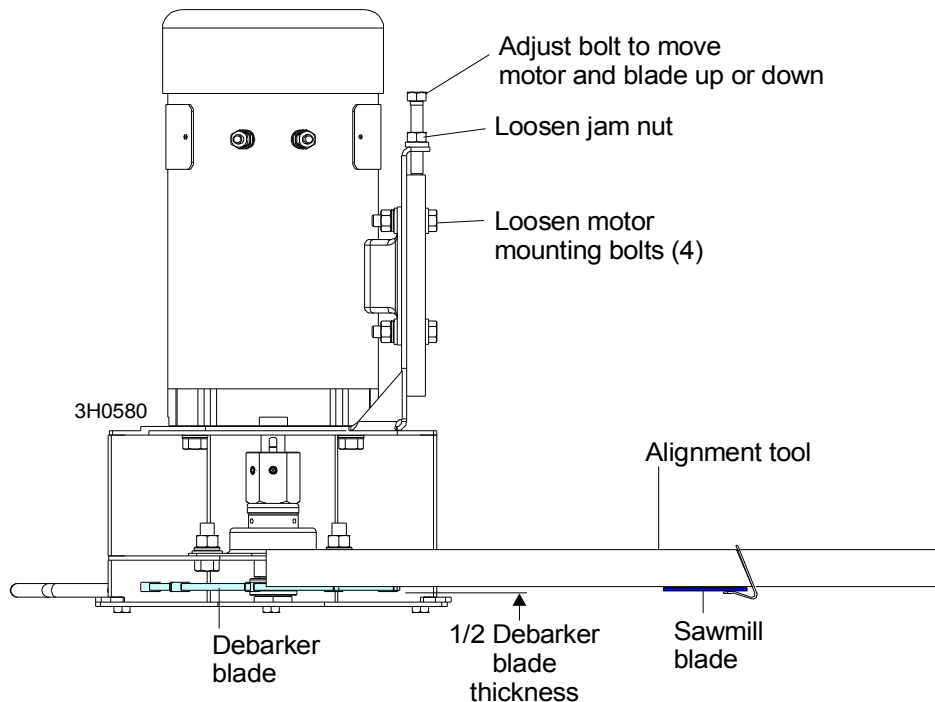

FIG. 3-2

- Check the height of the debarker blade against the alignment tool. The bottom edge of the tool should align with the center of the debarker blade.

To adjust the blade up or down, loosen the four blade motor mount bolts. Loosen the jam nut on the adjustment bolt. Turn the adjustment bolt clockwise to push the motor and blade down. Turn the adjustment bolt counterclockwise and slide the motor up to raise the motor and blade. Retighten the adjustment bolt jam nut and four motor mount bolts.

- Insert the key and use the debarker in/out switch to move the debarker all the way out. Turn the key to OFF (0) and remove the key.
- Move the blade guide alignment tool on the sawmill blade and check the position of the debarker blade against the tool. If the debarker blade is not centered with the tool, readjust the debarker mounting bolts to adjust the debarker assembly parallel to the blade.

- 7. If the debarker blade tends to climb during use, this indicates the blade is tilted up. Remove the shim located at the pivot arm stop to tilt the debarker blade down. Remove the two stop block mounting screws, remove shim and replace the stop block and mounting screws.

See Figure 3-3.

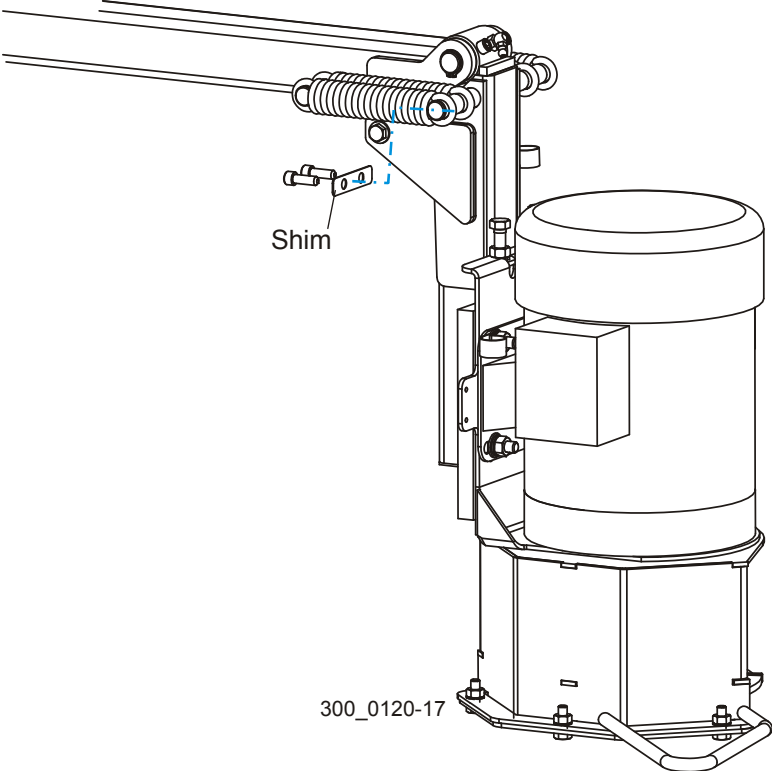

FIG. 3-3

3 Debarker Installation

SECTION 4 OPERATION AND MAINTENANCE

4.1 Locking Pin Operation

See Figure 4-1. The debarker is equipped with a locking pin located where the debarker frame pivots in the mounting blocks. One hole location is provided for the locking pin. Turn the locking pin to the right to lock the debarker in place when towing the sawmill. Turn the locking pin to the left to unlock the debarker while the debarking is required during sawing.

Before operating the debarker, make sure the locking pin is secured in its travel position. Turn the key switch to OFF (0) and remove the key. Pull the debarker out to relieve pressure on the locking pin. Pull the pin up and rotate so the small roll pin is aligned with the disengaged position. Release the locking pin.

Before towing the sawmill, lock the debarker in the travel position. Turn the key switch to ACC (3) and use the debarker in/out switch to move the debarker all the way in. Turn the key to OFF (0) and remove the key. Push the debarker in until the travel position hole aligns with the locking pin. Pull the pin up and rotate until the small roll pin is aligned with the travel position slot. Release the locking pin.

To move the debarker out of the way during sawing, turn the key switch to ACC (3) and use the debarker in/out switch to move the debarker all the way out.

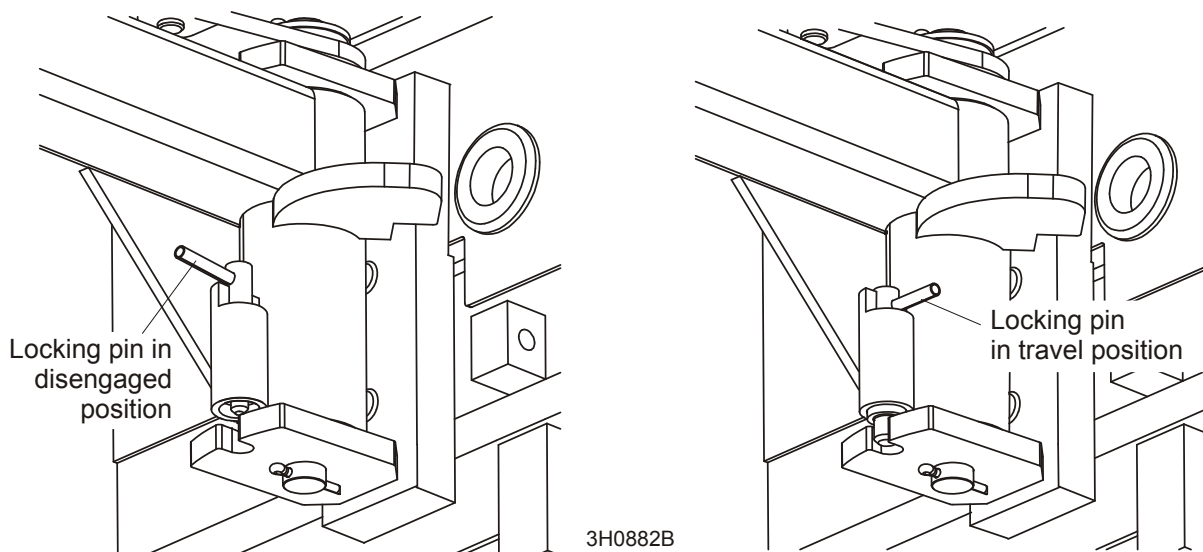

FIG. 4-1

4.2 Control Overview

The Debarker Option allows you to remove bark from logs ahead of the bandsaw blade. This prevents the bandsaw blade from contacting dirt, sand, or other debris in the bark that can dull the blade.

See **Figure 4-2**. The debarker control includes two toggle switches, an indicator light, and circuit breakers with manual reset.

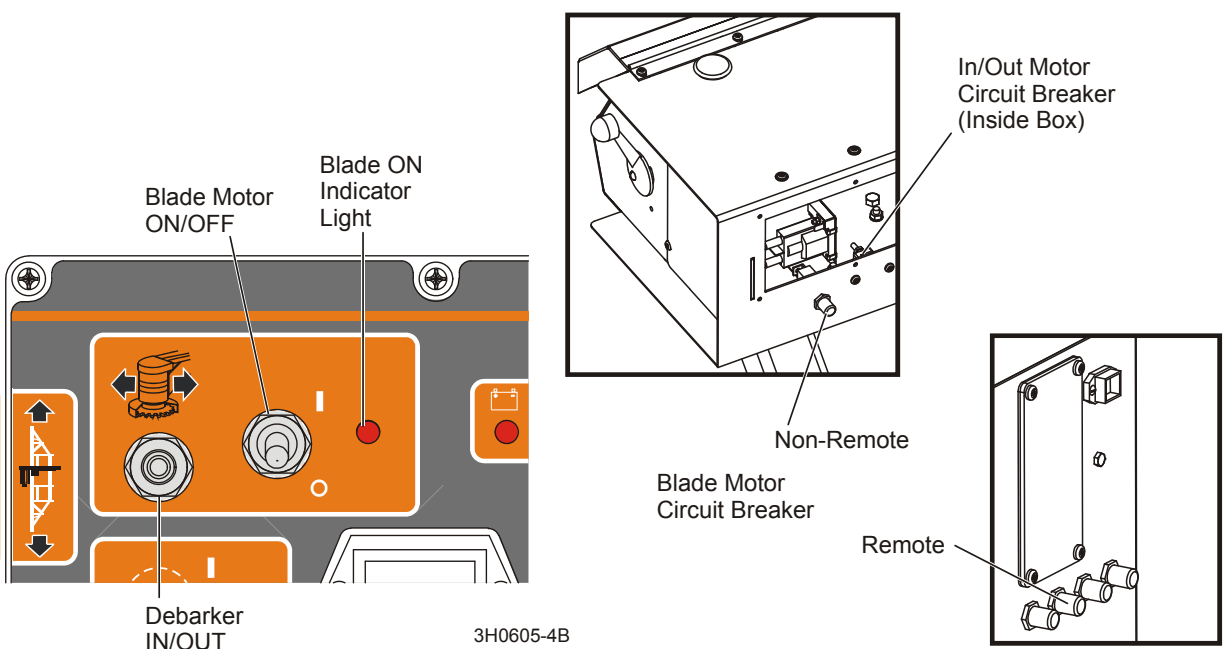

FIG. 4-2

- The Debarker IN/OUT toggle switch controls the debarker in/out motor to move the debarker cutting head toward or away from the log. The sawmill key switch must be on before the in/out function can be performed. **NOTE:** The distance between the debarker blade and the side support with the cutting head all the way in is 6" (150mm) for the sawmill equipped with the standard head and 12" (300mm) for the sawmill equipped with the wide head.
- The Blade Motor ON/OFF toggle switch turns the blade motor on to start the debarker blade. The sawmill key switch must be on and the sawmill power feed drum switch must be activated in the forward direction before the blade motor can be turned on.
- The Blade ON indicator light comes on whenever the debarker blade motor is on.

- **Non-Remote Sawmills:** The blade motor circuit breaker can be reset by pushing the boot-covered tab on the back of the control box.
- **Remote Sawmills:** The blade motor circuit breaker can be reset by pushing the boot-covered tab on the side of the remote power box.

4.3 Operation



DANGER! Make sure all guards and covers are in place and secured before operating the debarker option. Failure to do so may result in serious injury.

DANGER! Keep all persons out of the path of moving equipment when operating the debarker. Failure to do so will result in serious injury.

1. Remove the blade motor cover before operating the debarker.
2. Make sure the warning light is on when the debarker is turned on.



WARNING! Debarker is ON when warning light is on. DO NOT disconnect the warning light. Doing so may result in serious injury.

3. Use the in/out switch on the control box to pivot the debarker all the way out.



4. Move the sawmill carriage forward and pivot the debarker in until the front fence engages with the end/side of the log.
5. Turn the debarker on/off switch to ON (1).



6. Proceed with cutting. The actuator will keep the debarker against the side of the log. Depending on log shape, you may have to pivot the debarker in and out for smooth cutting.



NOTE: The debarker can continuously remove up to approximately 1" of material from the log; no motor cool down time is required. Slower feed rates may be required for optimal debarker operation.

7. Once the carriage is past the end of the log, pivot the debarker away from the log. Return the carriage.



IMPORTANT! Should the carriage be returned before the debarker has been pivoted out of the way of the log, the debarker is designed to pivot upwards. If this happens, continue to **SLOWLY** return the carriage; or stop, pivot the debarker out and then return the carriage. **DO NOT** move the carriage forward while the debarker is contacting the log without the blade spinning.

8. When done sawing and ready to store or transport the sawmill, replace the debarker blade motor cover. Place the debarker in its travel position before towing the sawmill ([See Section 4.1](#)).

4.4 Maintenance



DANGER! Before performing any service to this equipment, turn the key to the OFF (0) position and remove the key. Failure to do so will result in serious injury or death.

1. Lubricate the pivot joint with a NLGI #2 grade lithium grease every 40 hours of operation.

See Figure 4-3.

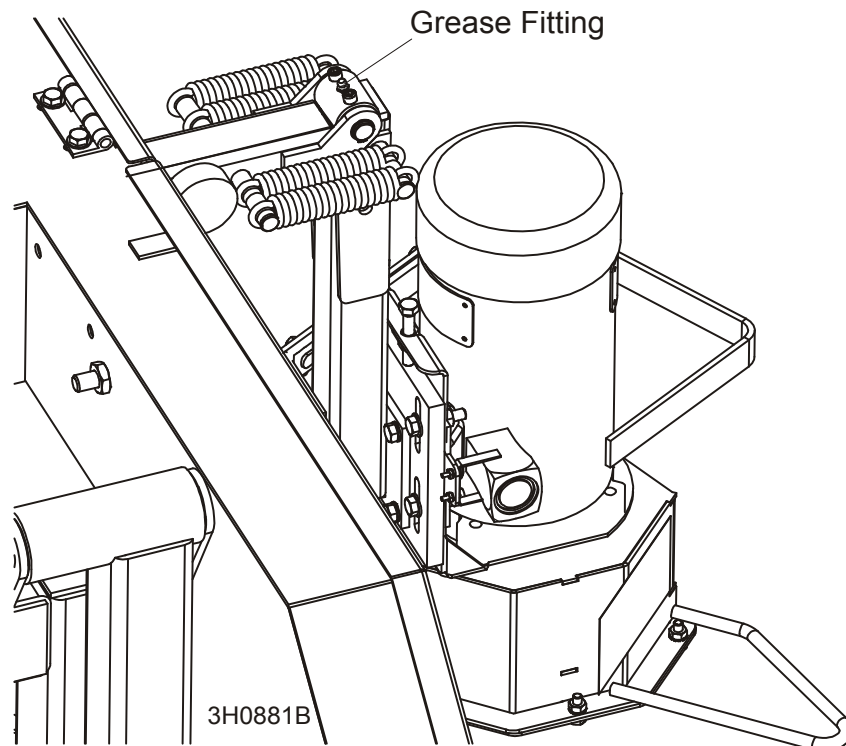

FIG. 4-3

2. Periodically check the flexible guard. Adjust the guard up or down so the bottom is even with the bottom of the debarker blade. Replace the guard as needed.
3. Lubricate the spring rod daily with Automatic Transmission Fluid (ATF) such as Dexron III.

NOTE: Debarkers before 11/06 had a grease fitting to lubricate the spring rod with grease. Use ATF rather than grease to lubricate the arm.

4. Periodically check the debarker blade. Align or replace as needed.



WARNING! Before replacing the debarker blade, move the sawmill blade guide arm in front of the sawmill blade to cover the blade teeth. Failure to do so may result in serious injury or death.

To replace the debarker blade, remove the lower blade guard plate. Place one wrench on the blade arbor, above the blade bearing. Place the other wrench on the lower bolt and rotate clockwise (bolt has left-hand threads). Remove the bolt and washer. Remove the blade and spacer.

Reinstall the spacer with the new blade. Reinstall the bolt and washer and turn counter-clockwise to tighten to 35 foot-pounds (± 5). Reinstall the blade guard plate.



CAUTION! Tighten the blade bolt manually. Using power-assisted tools may result in over-torquing and damage to the bolt.

4.5 Troubleshooting



DANGER! Before performing any service to this equipment, turn the key to the OFF (0) position, remove the key, and disconnect the sawmill battery ground terminal. Failure to do so will result in serious injury or death.

PROBLEM	CAUSE	SOLUTION
70 amp circuit breaker tripping	Wood or bark jammed in blade guard	Turn key to OFF position, remove key. Remove wood or bark from blade guard
	Pivot pin is binding.	Inspect for bind by moving debarker head to full in position. Turn key to OFF position, remove key. Pull arm to full out position by hand. If available, use a weight scale to pull arm to full out position. Should not have more than 12 pounds of resistance to pull out. Ensure pivot pin has been greased properly. Check pivot clamps for correct installation. Loosen pivot clamp bolts slightly, check for reduced binding
	Ring terminal of red wire touching debarker motor housing at motor	Move terminal away from motor housing. Reset circuit breaker and retest.
Light comes on, but debarker motor and warning light do not operate	Circuit breaker weak from repeated tripping.	Replace circuit breaker
	Circuit breaker tripped	Reset circuit breaker.
Debarker shuts off, but the circuit breaker is not tripped.	Bad ignition wire connection	Check ignition wire connection outside and inside of debarker control box.
	Intermittent key switch	Replace key switch
	Other loose wiring connection	Check wiring connections inside control box.
Debarker will not shut off.	Solenoid is stuck closed.	Replace solenoid.
IN/OUT Motor does not move IN or OUT	Drive belt too loose	Tighten enough to allow movement. DO NOT OVER-TIGHTEN.
	Switch not working properly	Check wiring to switch for loose connections. If wiring looks OK, replace switch.
	Torsion spring too tight	Loosen the spring tensioning nut (part #10) until the last few threads of the retainer bushing are engaged by the nylon in the nut.

SECTION 5 ELECTRICAL INFORMATION

5.1 Electrical Symbol Diagram (Non-Remote)

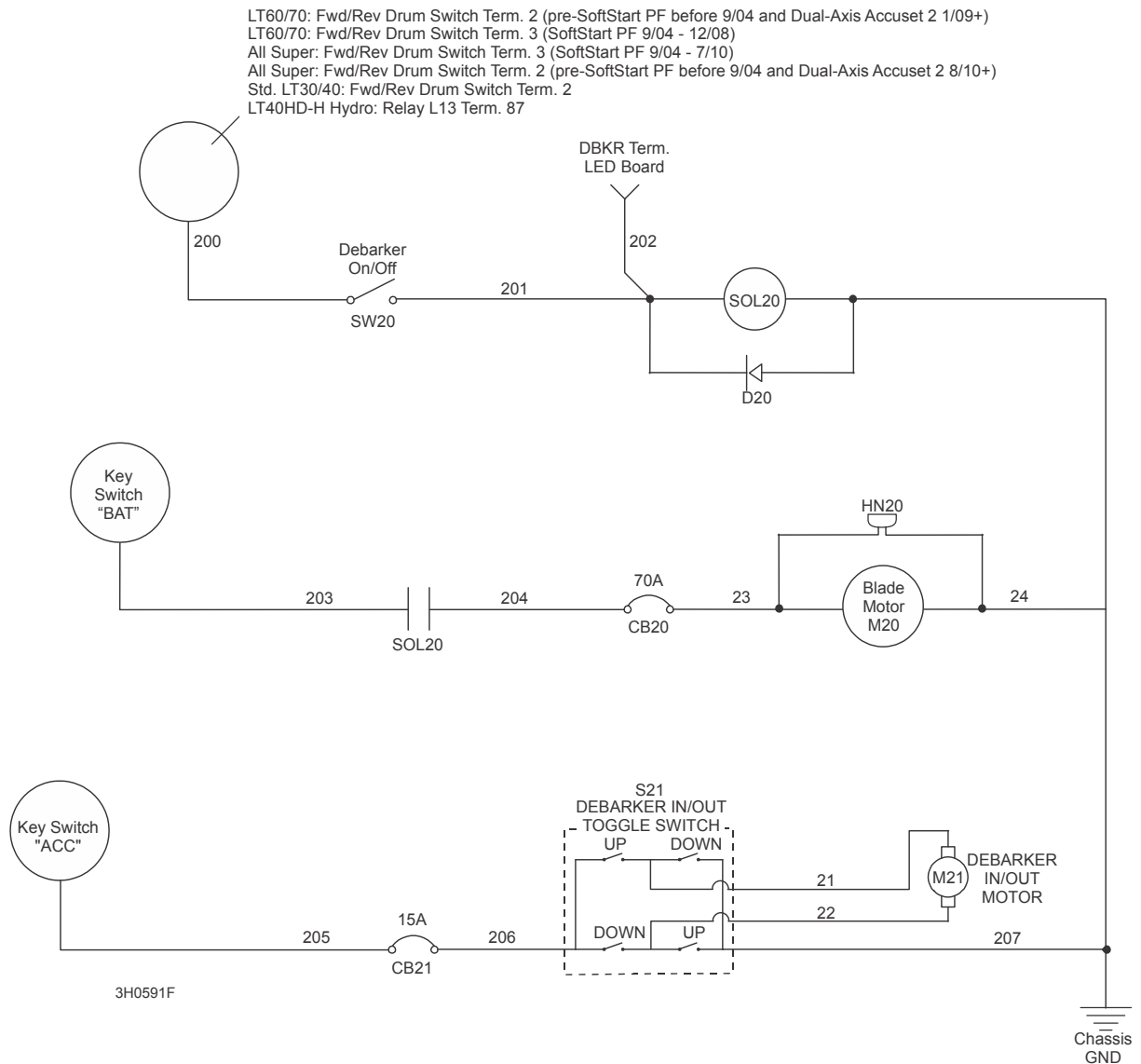

FIG. 5-1 NON-REMOTE SAWMILL

5.2 Electrical Symbol Diagram (Remote)

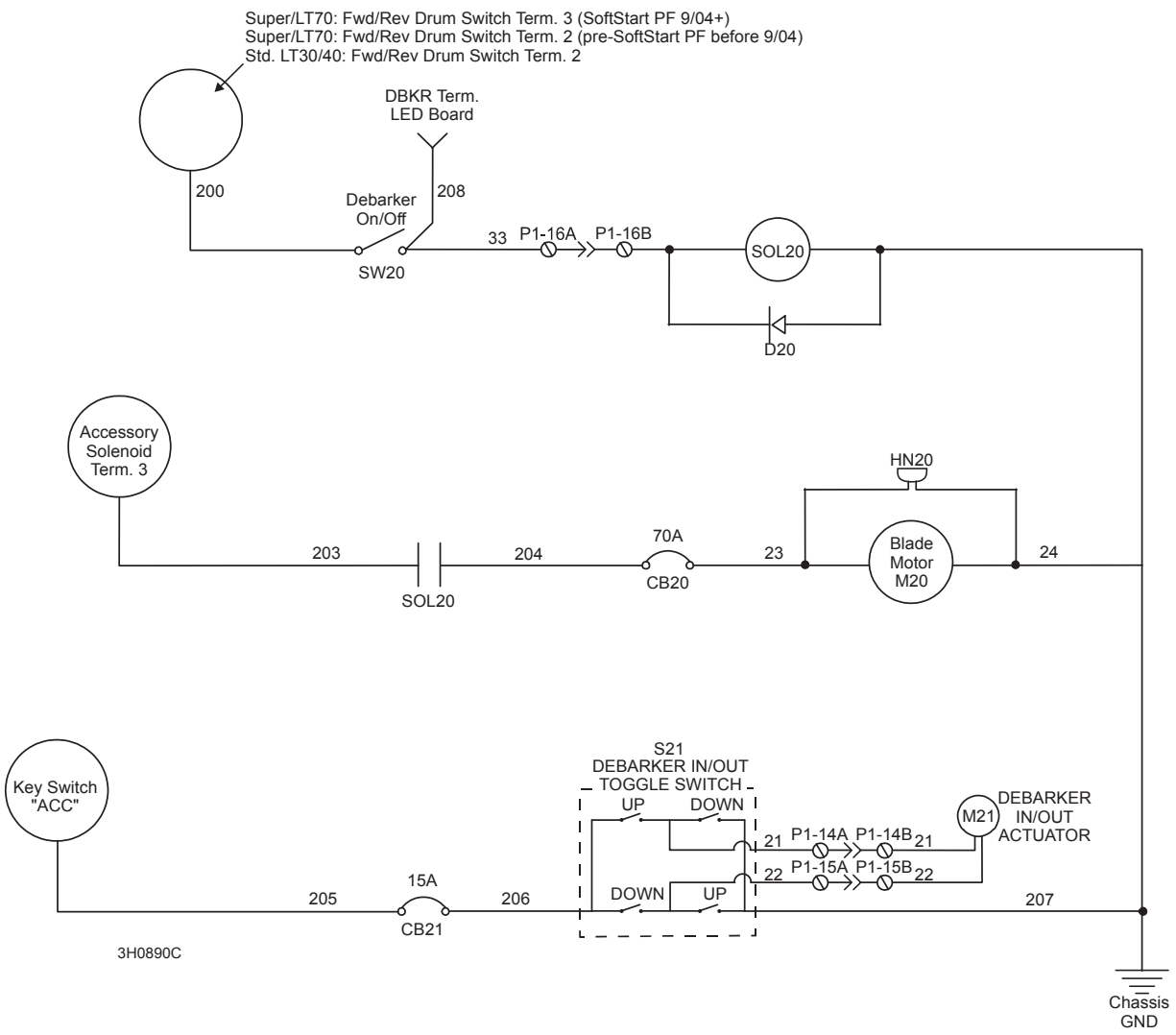

FIG. 5-2 REMOTE SAWMILL

5.3 Electrical Component List

ID	Wood-Mizer Part No.	Description
CB20	015527	Breaker, 70 A Manual Reset Panel Mount Circuit
CB21	E20430	Breaker, 15 Amp
D20	015426	Diode Assembly, Solenoid Coil Chassis
HN20	073555	Light Assembly, Debarker ON Warning Strobe
HN20	021137	Horn, Debarker ON Warning (Prior to Rev. C.05+)
	069431 ¹	Horn Assembly, DCS Debarker ON Warning (Debarker Equipped with Horn Only)
M20	023688	Motor, 12 V DC 3/4HP TEFC W/Base 7/8" Dia. Shaft
M21	P09698-1 ²	Motor, 53:1 Gear
	053421 ¹	Motor Assembly, DCS Blade Guide Debarker In/Out
	034487 ²	Actuator, Linear E050 4 Stroke
SOL20	016372	Solenoid, 12V 100A Cont Duty GND Coil
SW20	P03027	Switch, Toggle
SW21	024200	Switch, DPDT Toggle

¹ Optional components for DCS version of the LT70HD Remote.

² Gear Motor supplied after Rev. B.00. Actuator supplied on Rev. A.00 no longer available. Upgrade actuator with new swing arm retrofit 036304.

5.4 Electrical Wiring Diagram (non-Remote Sawmills)

LT60HD/70HD

Rev. B3.00+

This diagram applies to non-Remote LT60HD/70HD model sawmills built after 1/09 with dual-axis Accuset 2 system.

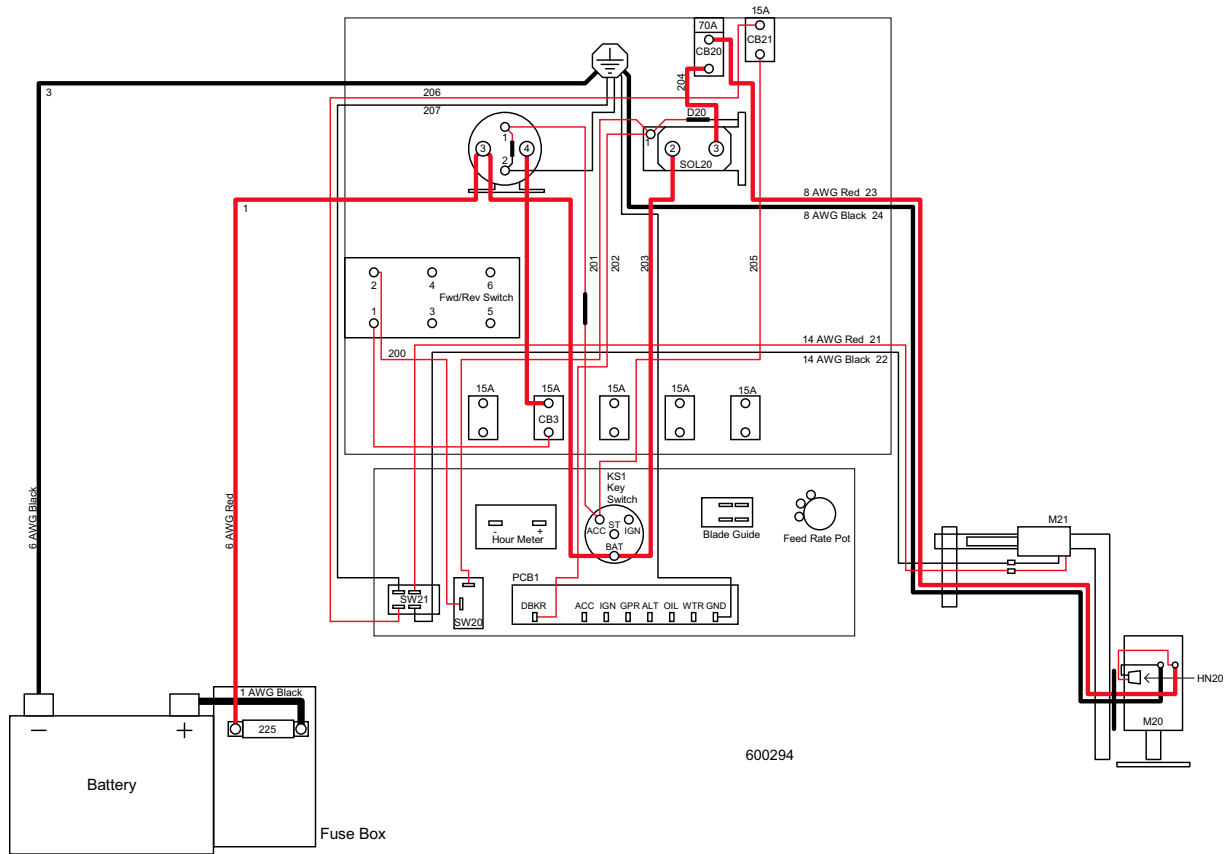

FIG. 5-3

5 **Electrical Information**
LT60HD/70HD Rev. A4.00 - B2.00

LT60HD/70HD Rev. A4.00 - B2.00

This diagram applies to non-Remote LT60HD/70HD model sawmills built between 9/04 and 12/08 with softstart power feed system.

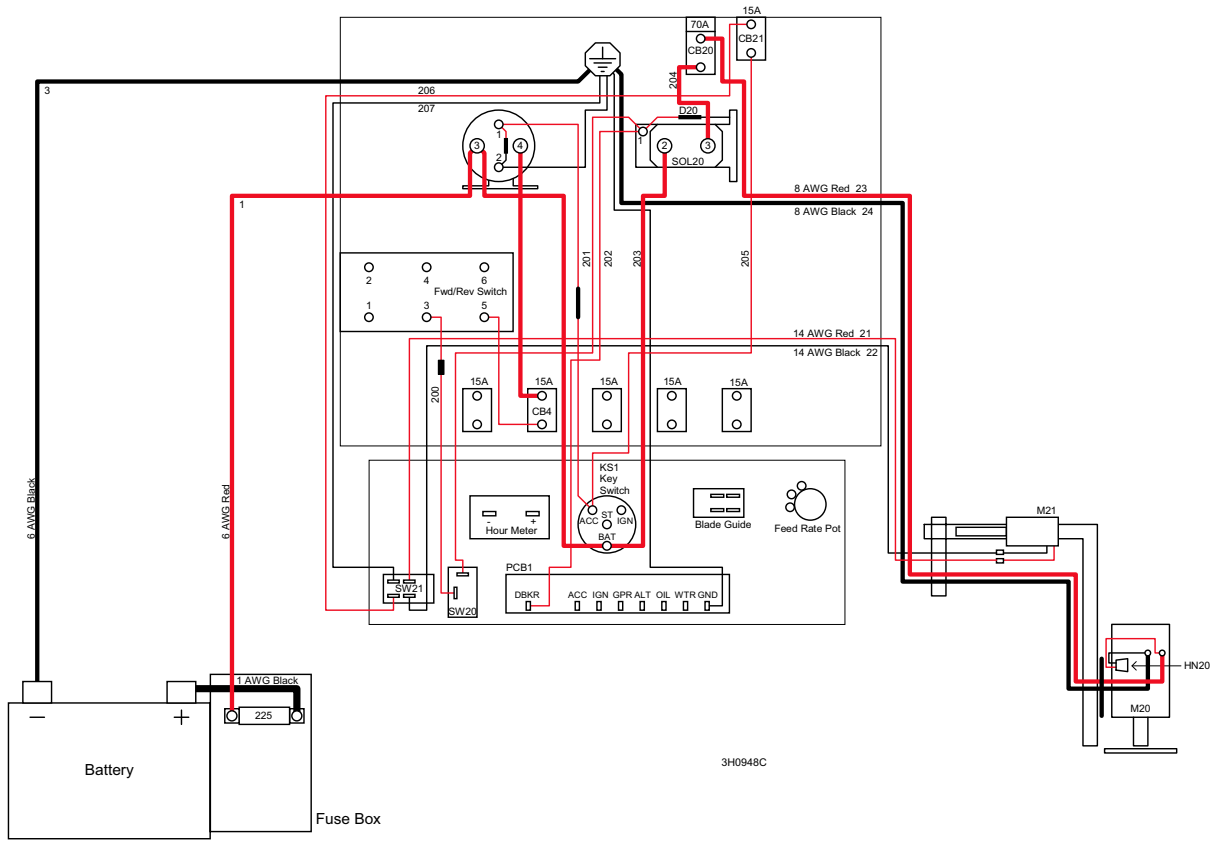

FIG. 5-4

LT60HD/70HD

Rev. A1.00 - A3.03

This diagram applies to non-Remote LT60HD/70HD model sawmills built before 9/04.

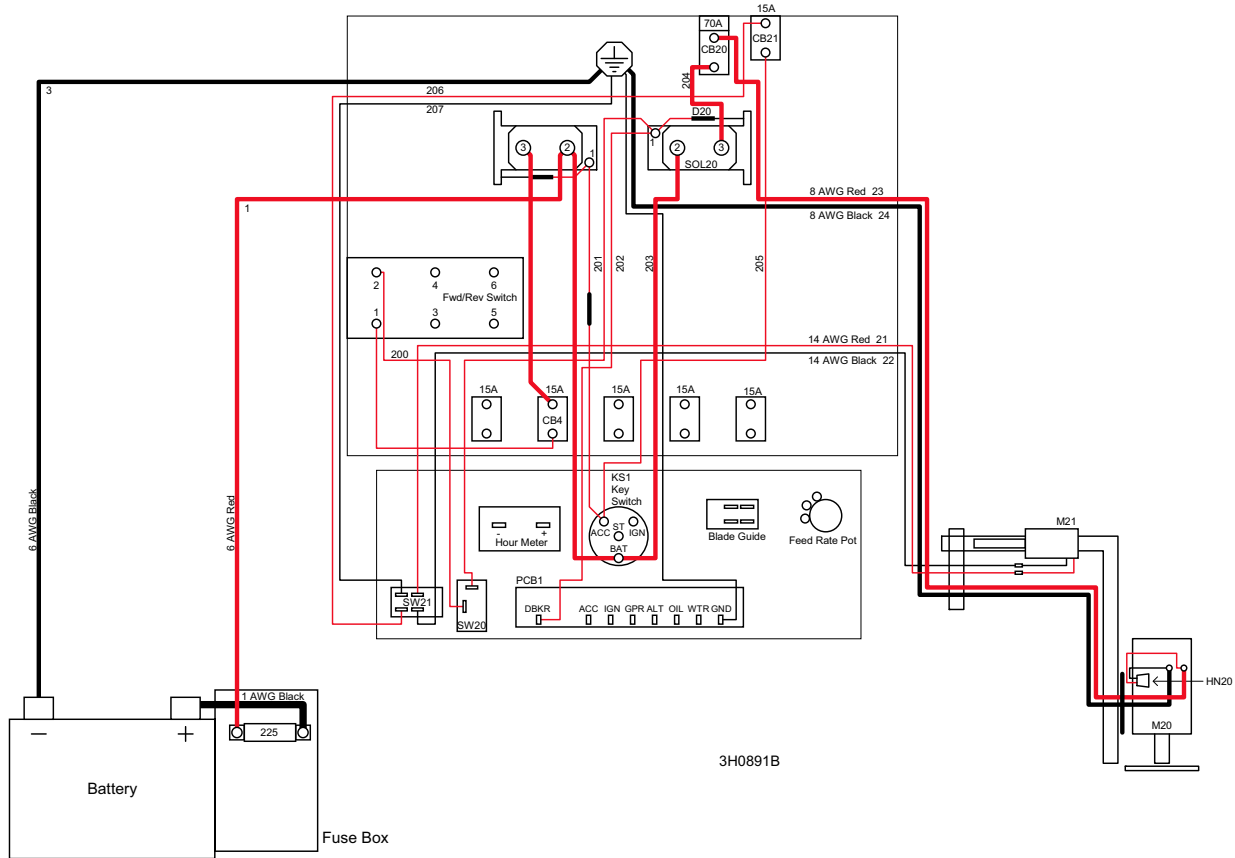

FIG. 5-5

5 Electrical Information

Electrical Wiring Diagram (Remote Sawmills)

5.5 Electrical Wiring Diagram (Remote Sawmills)

LT70HD Remote *Rev. B3.00+*

This diagram applies to Remote LT70HD model sawmills built after 1/09 with dual-axis Accuset 2 system.

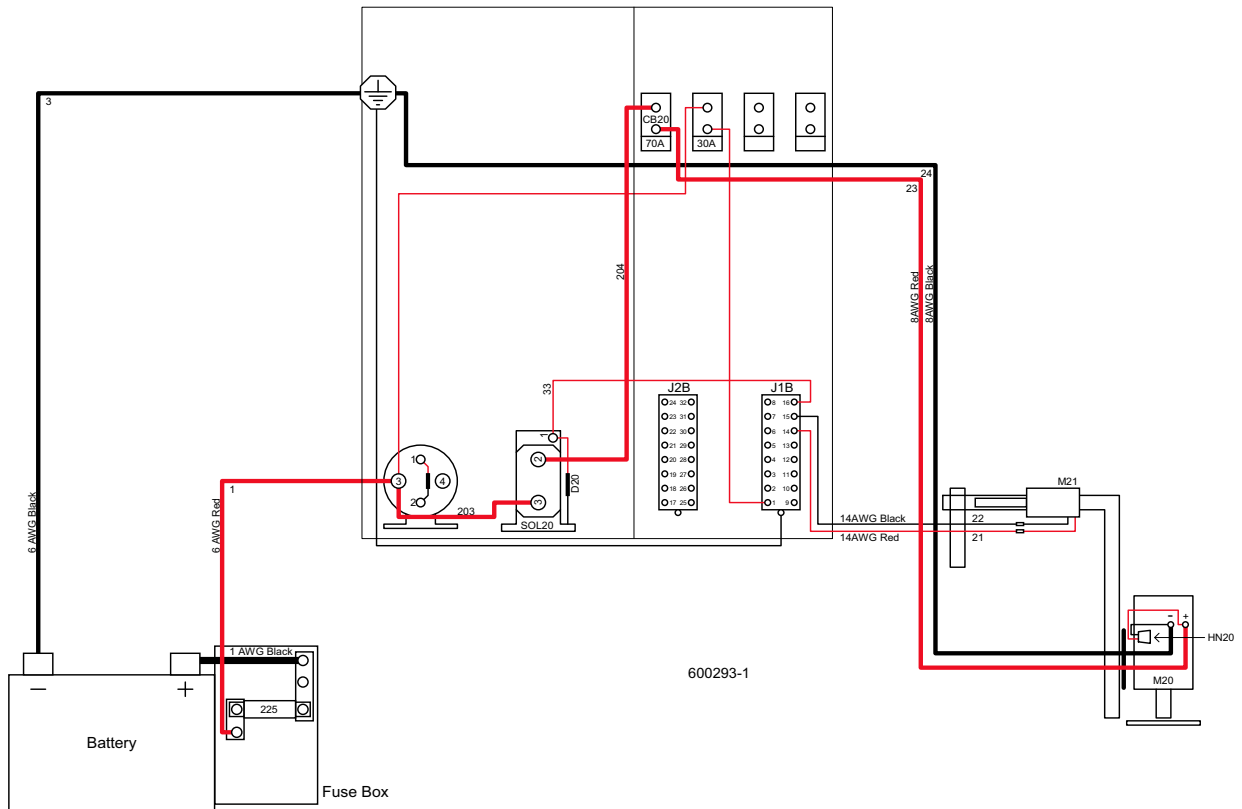

FIG. 5-6 (PAGE 1 OF 2)

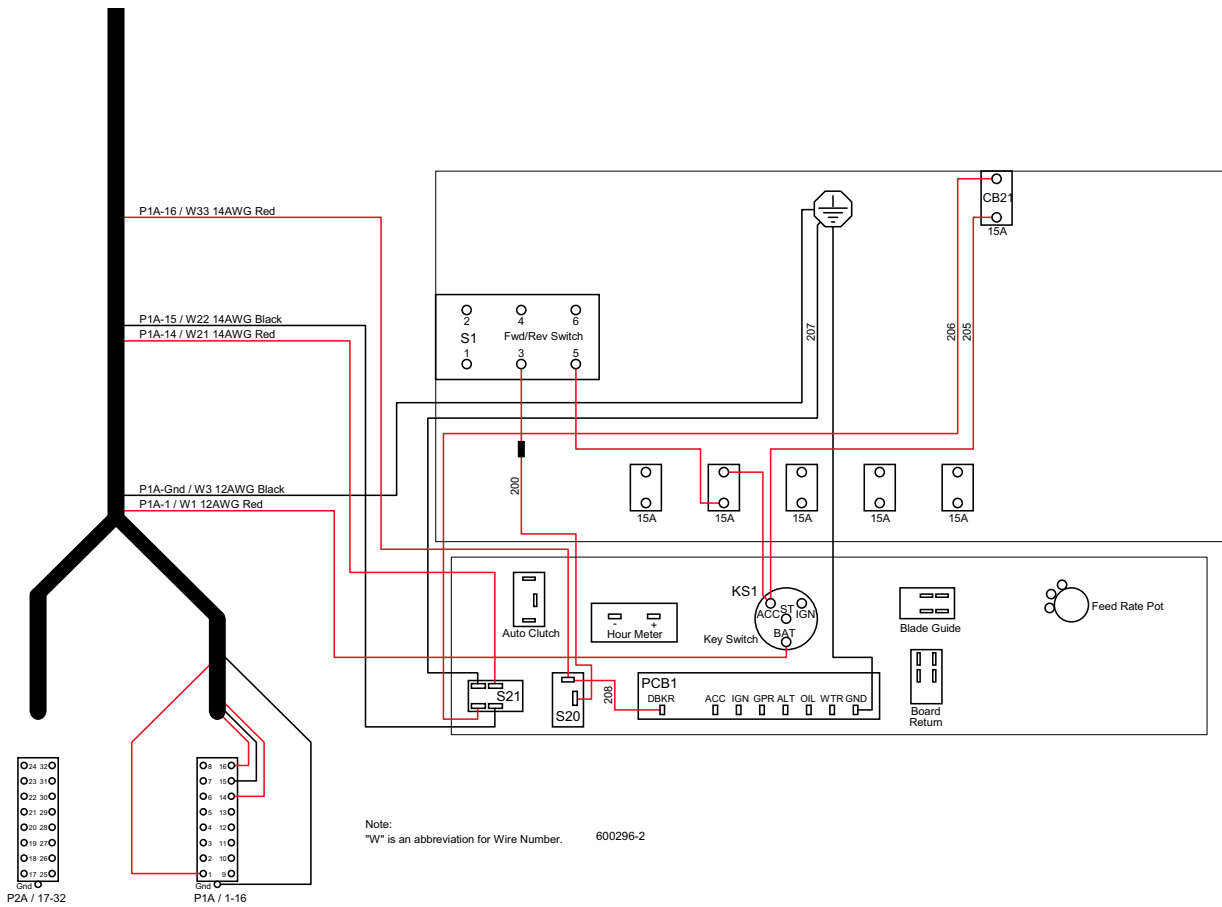

FIG. 5-7 (PAGE 2 OF 2)

This diagram applies to Remote model sawmills built after 1/09 with dual-axis Accuset 2 system.

LT70HD Remote Rev. A4.00 - B2.00

This diagram applies to Remote LT70HD model sawmills built between 9/04 and 12/08 with softstart power feed system.

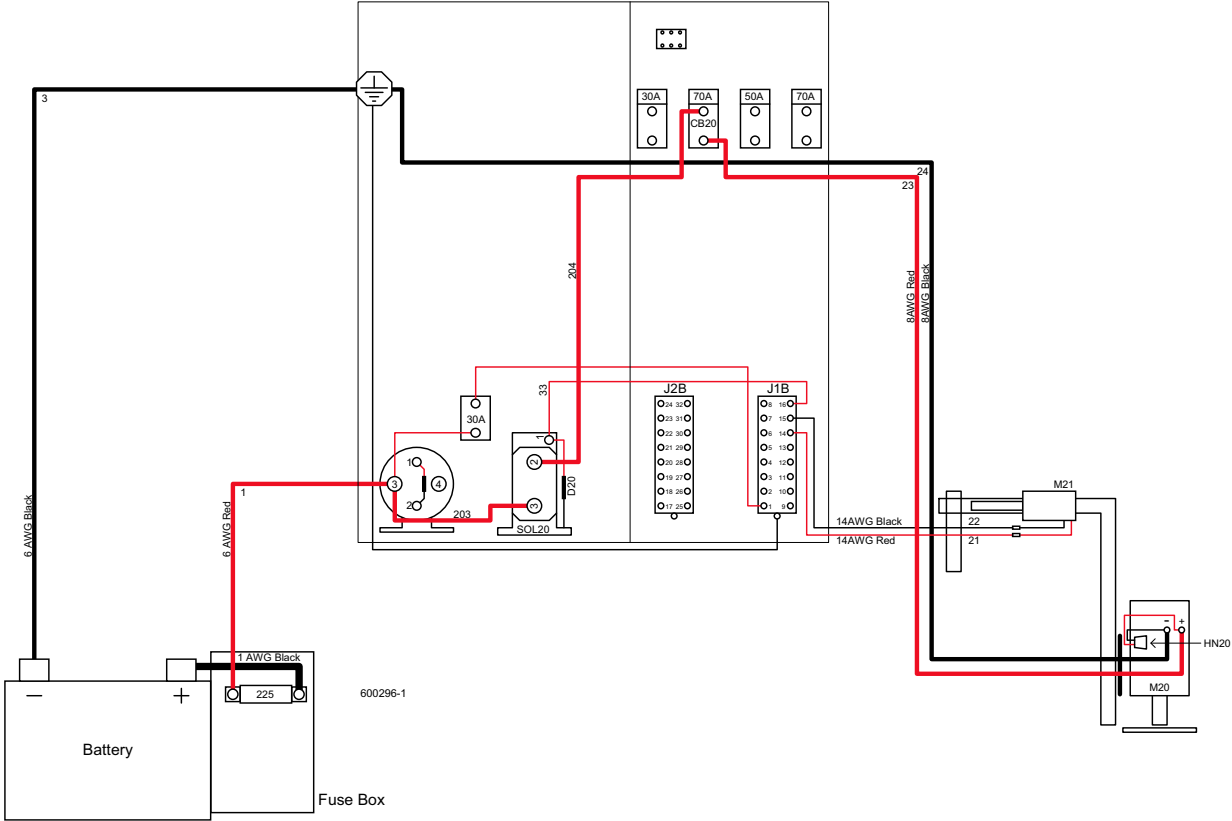

FIG. 5-8 (PAGE 1 OF 2)

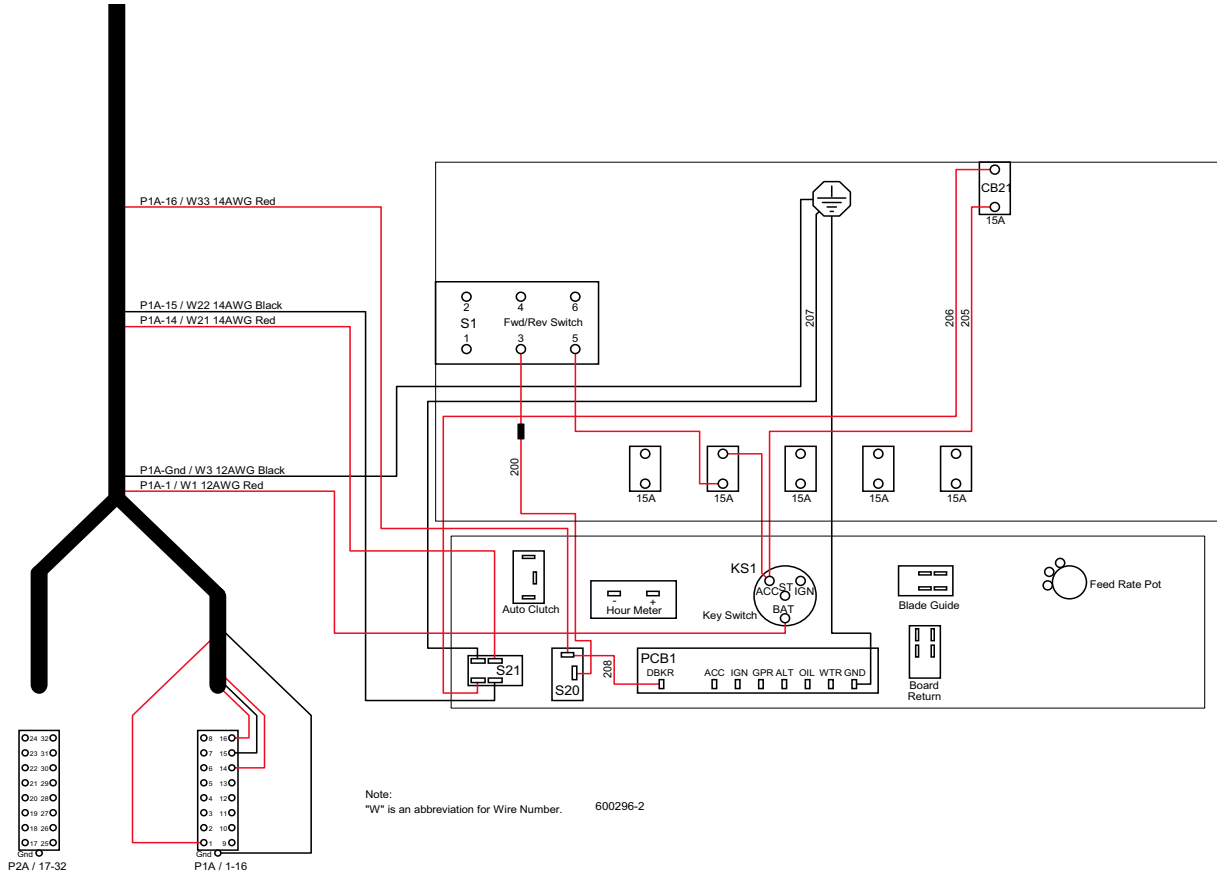

FIG. 5-9 (PAGE 2 OF 2)

5 **Electrical Information**
LT70HD Remote Rev. A1.00 - A3.03

LT70HD Remote

Rev. A1.00 - A3.03

This diagram applies to Remote LT70HD model sawmills built before 9/04.

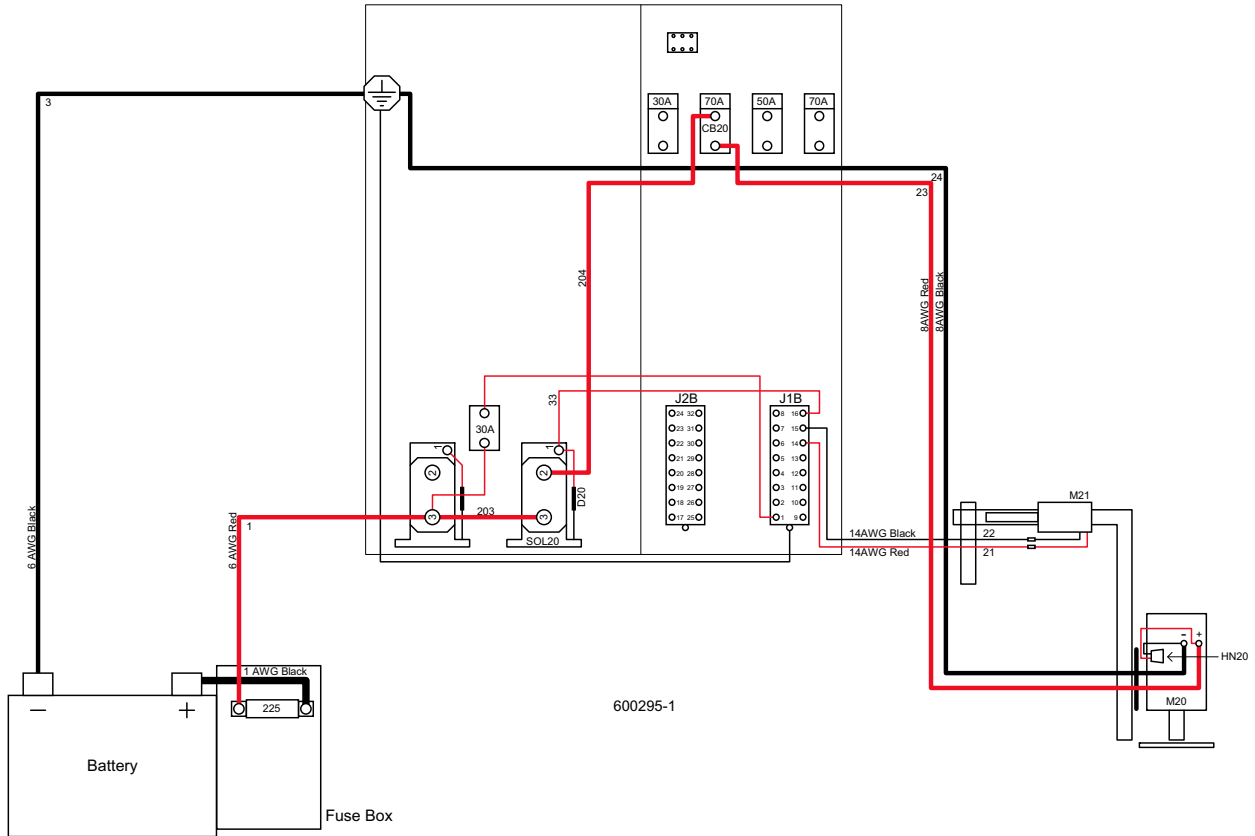

FIG. 5-10 (PAGE 1 OF 2)

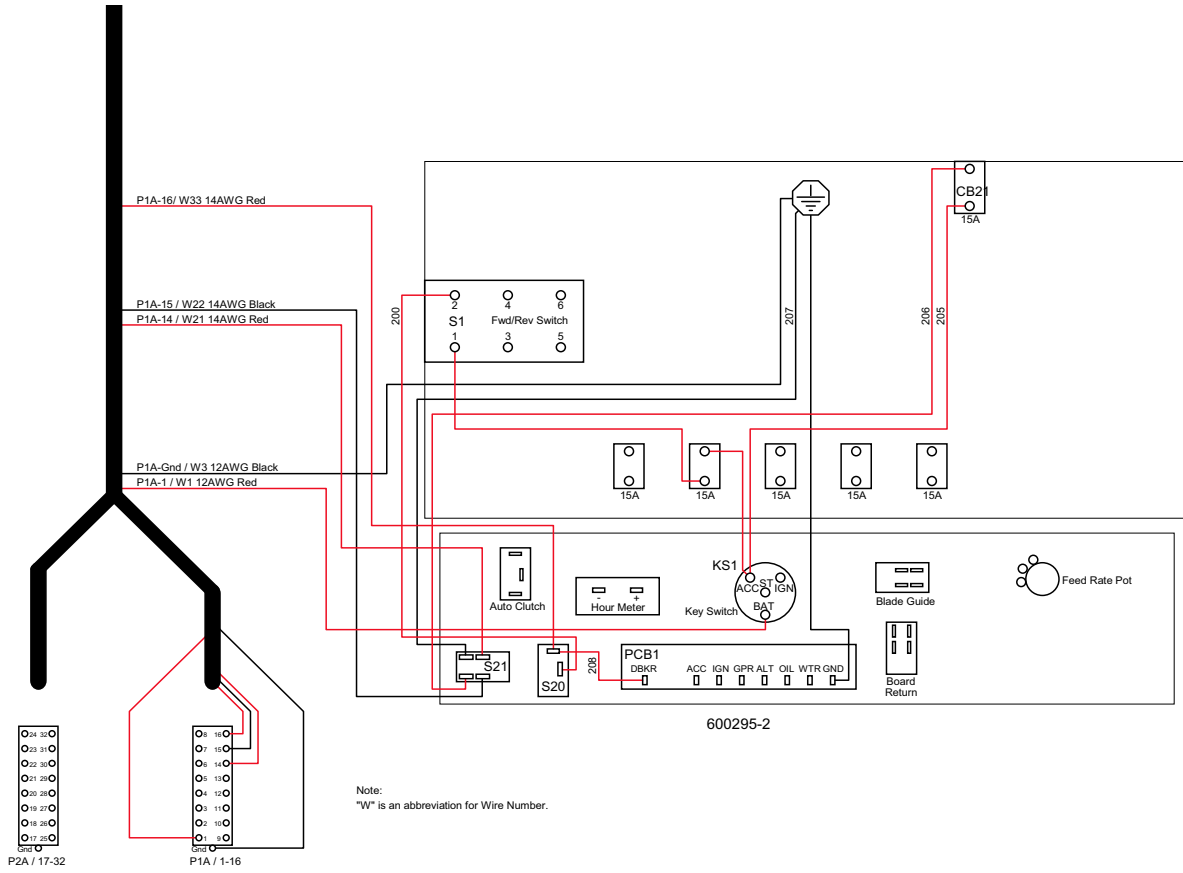

FIG. 5-11 (PAGE 2 OF 2)

5 Electrical Information

Electrical Wiring Diagram (DC Wireless Sawmills)

5.6 Electrical Wiring Diagram (DC Wireless Sawmills)

LT70HD DC Wireless Rev. A9.00+

This diagram applies to Wireless LT70HD DC model sawmills.

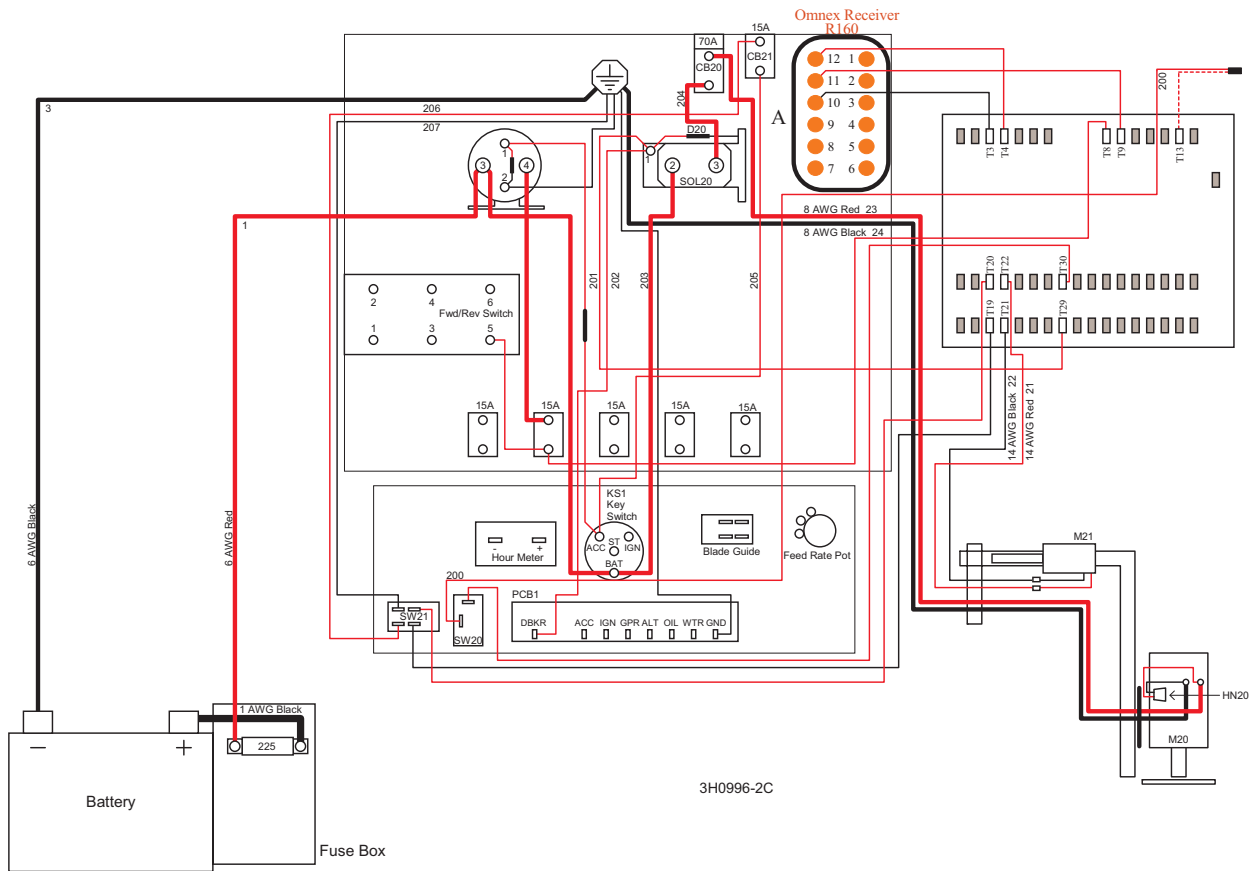
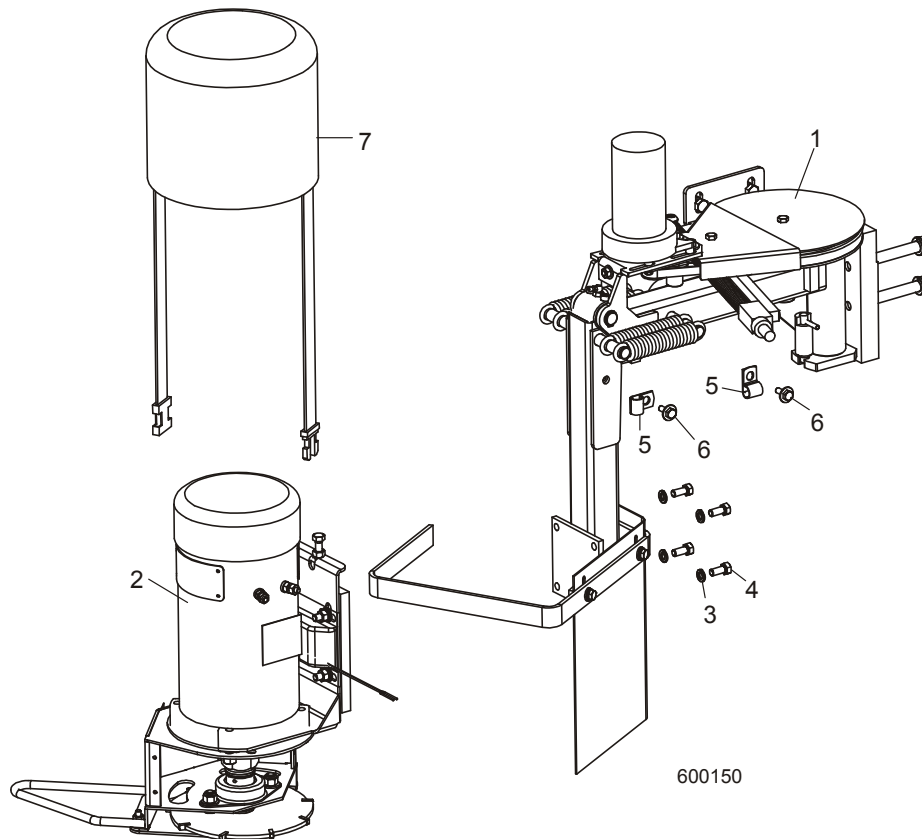

FIG. 5-12

SECTION 6 DEBARKER PARTS

6.1 Mechanical Assembly



REF	DESCRIPTION (◆ Indicates Parts Available In Assemblies Only)	PART #	QTY.
For field installation of existing sawmills, order the mechanical assembly below plus the appropriate control kit (See Section 6.9):			
	MECHANICAL ASSEMBLY, LT60HD/70HD DC MKII DEBARKER (BOXED)	017714	1
1	Frame Parts (See Section 6.3)		
2	Cutter Head Parts (See Section 6.6)		
3	Washer, 5/16" Split Lock	F05011-13	4
4	Bolt, 5/16-18 x 3/4" Hex Head	F05006-5	4
5	Clamp, 1/2" EMT Coated	P07584	2
6	Bolt, 1/4-20 x 3/4" Hex Head w/Conical Washer Head	F05005-134	2
7	Cover, 3/4HP Leeson Motor	015761	1

5 Replacement Parts

6.2 Actuator Assembly

Rev. A.00

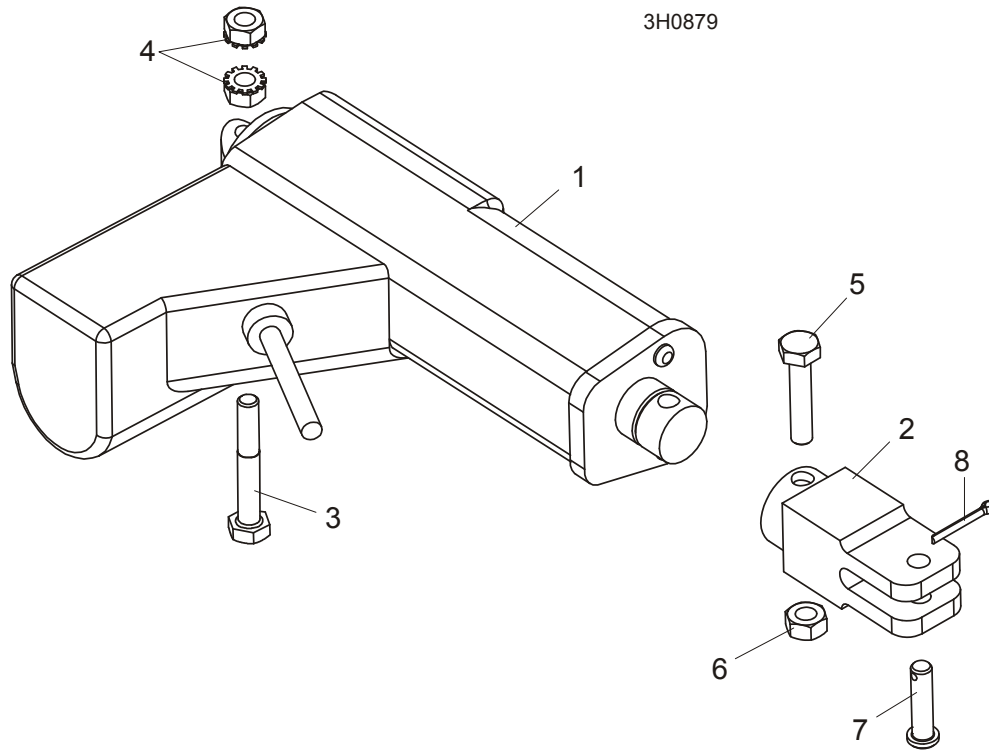

REF	DESCRIPTION (◆ Indicates Parts Available In Assemblies Only)	PART #	QTY.	
1	ACTUATOR ASSEMBLY, LINEAR DEBARKER LT70	050417 ¹	1	◆
2	CLEVIS, ACTUATOR DEBARKER	034569	1	
3	BOLT, 1/4-20 X 1 3/4 HEX HEAD GR2	F05005-4	1	
4	NUT, 1/4-20 KEPS	F05010-9	2	
5	BOLT, 1/4-20 X 1 1/4 HEX HEAD	F05005-3	1	
6	NUT, 1/4-20 SWAGED	F05010-21	1	
7	PIN, 1/4 X 1 CLEVIS	F05012-69	1	
8	PIN, 3/32 X 3/4 COTTER	F05012-9	1	

¹ Actuator assembly replaced with new frame arm with in/out gear motor to improve performance and durability ([See Section 6.3](#)). Use kit 036304 to retrofit Rev. A.00 Debarkers.

6.3 Frame Assembly

Rev. B.00+

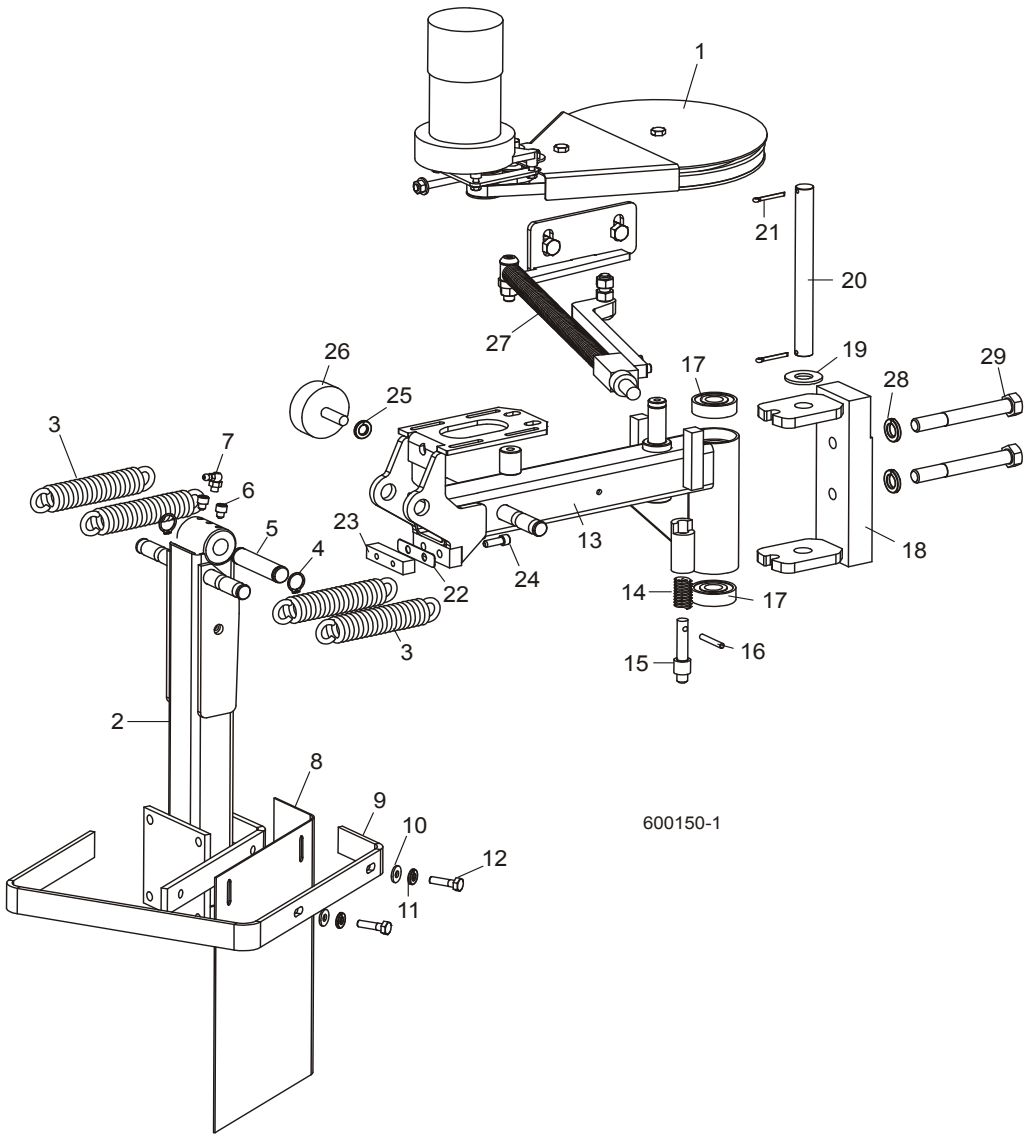

REF	DESCRIPTION (◆ Indicates Parts Available In Assemblies Only)	PART #	QTY.
	ARM ASSEMBLY, LT60/70 DEBARKER SWING	046030	1
1	Debarker In/Out Motor Parts (See Section 6.5)		
2	Frame Weldment, Lower LT60 Debarker	034365	1
3	Spring, Debarker Arm	021185	4
4	Ring, 5/8" Outer Retaining	F04254-2	2
5	Pin, Debarker Pivot	023646	1
6	Screw, 1/4-28 x 1/4" Socket Head	F05005-106	2

6

Debarker Parts*Frame Assembly*

7	Fitting, 1/4-28 90° Grease	P04108	1	
8	Guard, Debarker Flex	021232	1	
9	Guard, Debarker	021231	1	
10	Washer, 1/4" SAE Flat	F05011-11	2	
11	Washer, 1/4" Split Lock	F05011-14	2	
12	Bolt, 1/4-20 x 1" Hex Head	F05005-38	2	
	Frame Assembly, LT70 Debarker Upper	046031	1	
13	Frame Weldment, Debarker Upper	046032 ¹	1	
14	Spring, .58" OD x 1 1/2"	021243	1	
15	Pin, Debarker Lock	034814	1	
16	Pin, 3/16" x 1 1/4" Roll	F05012-16	1	
17	Bearing, 5/8" x 1.7548" x .4724"	P06030-1	2	
18	Mount Weldment, Debarker Pivot	046033	1	
19	Washer, 5/8" SAE Flat	F05011-5	1	
20	Pin, Debarker Pivot	046034	1	
21	Pin, 1/8" x 1" Cotter	F05012-1	2	
22	Shim, Pivot Stop	046045	1	
23	Block, Pivot Stop	046044	1	
24	Bolt, 1/4-20 x 1" Socket Head	F05005-89 ²	2	
25	Washer, 3/8" Split Lock	F05011-4	1	
26	Bumper, Rubber	034175	1	
27	Spring Arm Parts (See Section 6.8)			
28	Washer, 1/2" Split Lock	F05011-9	2	
29	Bolt, 1/2-13 x 4" Hex Head Grade 5	F05008-78	2	

¹ Frame Weldment 046032 modified Rev. B.02. Boss added to prevent lock pin from rotating during operation.

² Part corrected 12/08 (was F05005-26).

6.4 Frame Assembly

Rev. A.00

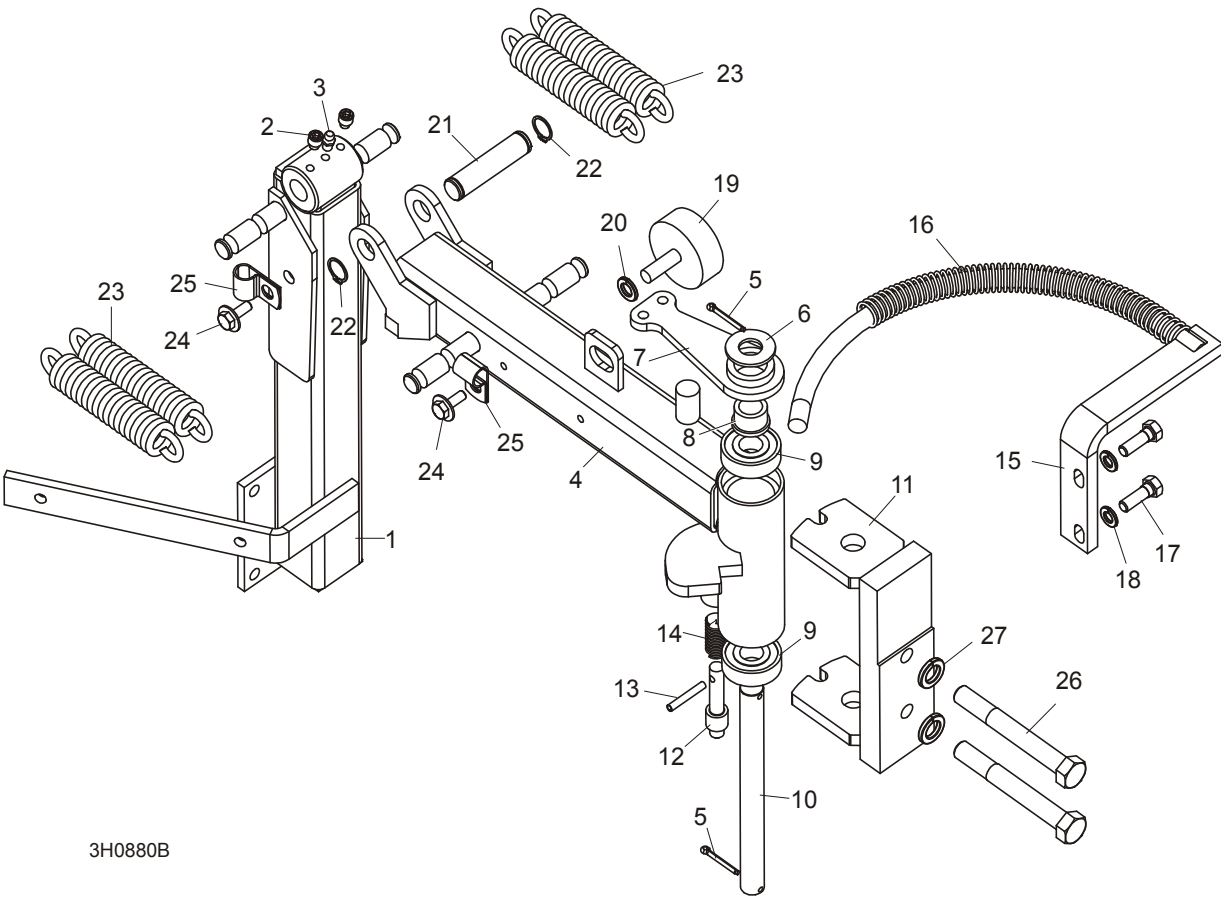

3H0880B

REF	DESCRIPTION (◆ Indicates Parts Available In Assemblies Only)	PART #	QTY.	
1	ARM WELDMENT, LOWER LT70 DEBARKER	034365	1	
2	SCREW, 1/4-28 X 1/4" SHC BO	F05005-106	2	
3	FITTING, 1/4-28 GREASE	P05060	1	
	ARM ASSEMBLY, UPPER LT70 DEBARKER	034399 ¹	1	◆
4	Arm Weldment, Swing Upper	034364	1	
5	Pin, 1/8 x 1" Cotter	F05012-1	2	
6	Washer, 5/8" SAE Flat	F05011-5	1	
7	Arm Weldment, Pivot Debarker	034483	1	
8	Bushing, 5/8" x 7/8" x 1/2" Bronz	P05135	1	
9	Bearing, 5/8" x 1.7548" x .4724"	P06030-1	2	
10	Pin, Pivot 5/8 x 7 3/16"	034304	1	
11	Mount Weldment, Debarker Pivot	034398	1	

6

Debarker Parts*Frame Assembly*

12	Pin, LT15 Lock	016053	1	
13	Pin, 3/16 x 1 1/4" Roll	F05012-16	1	
14	Spring, .58 OD x 1 1/8"	021243	1	
15	Guide, Spring Return Debarker	034847	1	
16	Spring, 3/4 O.D.x.08 Wire x 15 1/2 Lg.	034846	1	
17	Bolt, 5/16-18 x 1" HH Gr2	F05006-1	2	
18	Washer, 5/16" Split Lock	F05011-13	2	
19	BUMPER, TABLE	034175	1	
20	WASHER, 3/8" SPLIT	F05011-4	1	
21	PIN, PIVOT	023646	1	
22	RING, 5/8" OR 5100-62	F04254-2	2	
23	SPRING, DEBARKER ARM	021185	4	
24	BOLT, 1/4-20 X 3/4" W/CONICAL WASHER	F05005-134	2	
25	CLAMP, 1/2" EMT COATED	P07584	2	
26	BOLT, 1/2-13 X 4" HHB GR5 ZINC	F05008-78	2	
27	WASHER, 1/2" SPLIT LOCK	F05011-9	2	

¹ Arm assembly with In/Out gear motor replaces actuator driven arm ([See Section 6.3](#)). Use kit 036304 to retrofit Rev. A.00 Debark-ers.

6.5 In/Out Motor Drive Assembly

Rev. B.00+

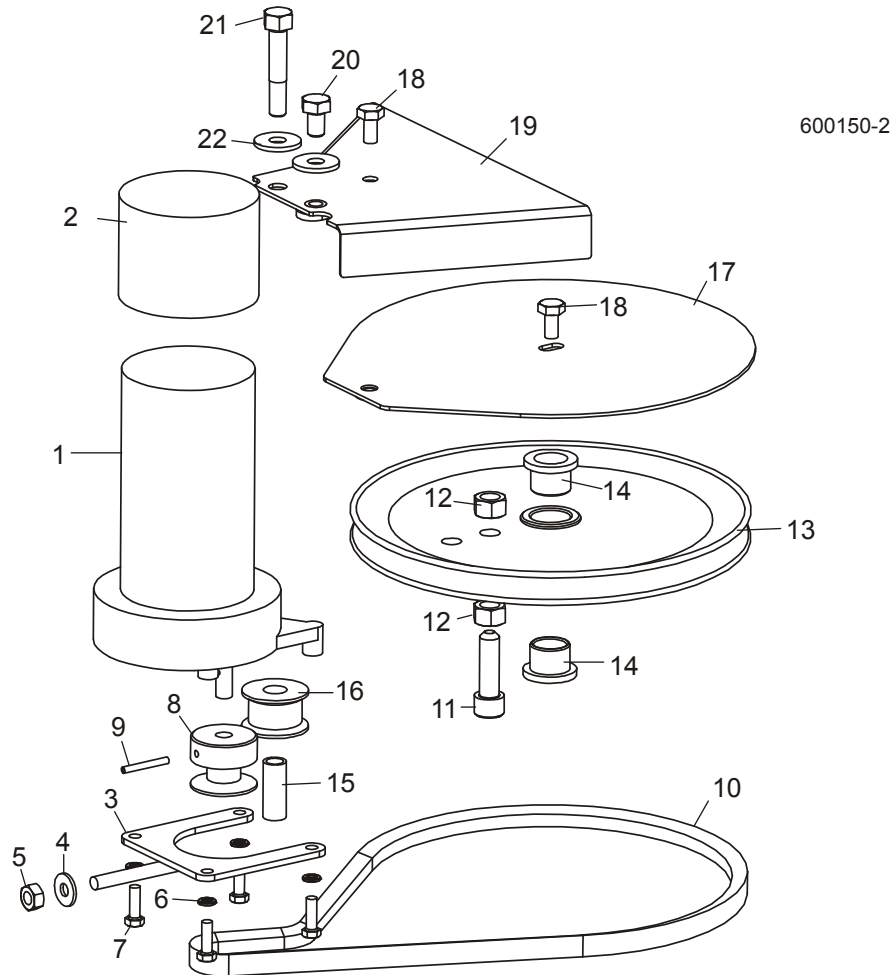

REF	DESCRIPTION (◆ Indicates Parts Available In Assemblies Only)	PART #	QTY.
1	MOTOR, CURRENT APPLICATIONS 1/30HP 12VDC GEAR	079214 ¹	1
	Gear Kit, Gear Motor Replacement	061232	1
	Brush Kit, Gear Motor Replacement	061234	1
	Shaft Kit, Gear Motor Replacement	061233	1
2	BOOT, GEAR MOTOR WEATHER	023720	1
3	TENSIONER WELDMENT, GEAR MOTOR	023637	1
4	WASHER, 1/4" SAE FLAT	F05011-11	1
5	NUT, 1/4-20 HEX LOCK	F05010-21	1
6	WASHER, #10 SPLIT LOCK	F05011-20	4
7	BOLT, #10-32 X 5/8" HEX HEAD	F05004-152	4
8	PULLEY, DEBARKER IN/OUT MOTOR	016181	1
9	PIN, 1/8" X 1" ROLL	F05012-34	1

6

Debarker Parts*In/Out Motor Drive Assembly*

10	BELT, AX29	046039	1	
11	BOLT, 3/8-16 1 1/4" SOCKET HEAD	F05007-150	1	
12	NUT, 3/8-16 HEX LOCK	F05010-25	2	
13	PULLEY, DEBARKER IN/OUT DRIVE	023634	1	
14	BUSHING, FLANGED BRONZE	021203	2	
15	SPACER, .322" ID X .44 OD X 1.10" LONG	046040	1	
16	GUIDE, BELT IDLER	S09999	1	
17	GUARD WELDMENT, DEBARKER BELT	046049	1	
18	BOLT, 1/4-20 X 1/2" HEX HEAD	F05005-15	2	
19	GUARD WELDMENT, DEBARKER PULLEY	046050	1	
20	BOLT, 5/16-18 X 1/2" HEX HEAD GRADE 5	F05006-15	1	
21	BOLT, 5/16-18 X 1 3/4" HEX HEAD	F05009-70	1	
22	WASHER, 5/16" STANDARD FLAT	F05011-16	2	

¹ Replaced P09698-1 1/30 HP 62RPM 12VDC 53:1 Gear Motor with P12756 End Housing, P12569 Gear Kit, P12800 Brush Kit and 009695 Shaft Kit (Rev. C.06).

6.6 Blade Motor Assembly

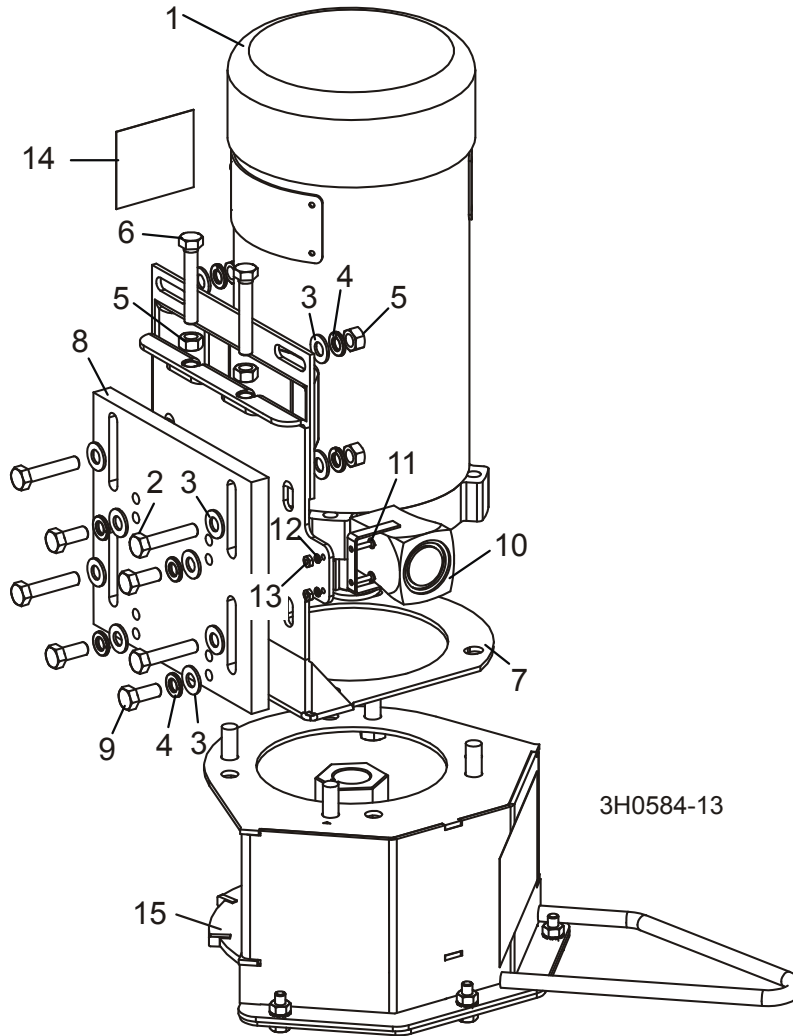

REF	DESCRIPTION (◆ Indicates Parts Available In Assemblies Only)	PART #	QTY.
	HEAD ASSEMBLY, MKII DEBARKER CUTTING	023618	1
1	Motor, 3/4HP 12VDC TEFC Electric (7/8" Dia. Shaft)	023688	1
	Brush Kit, Leeson 3/4HP Motor (Includes 2 Brushes and 2 Springs)	024167	1
	Fan, 3/4 HP Leeson Motor Replacement	016087	1
	Guard, Motor Fan	047998	1
	Key, 3/16" Square x 1 3/8" Long	016108	1
2	Bolt, 5/16-18 x 1 1/2" Hex Head Full Thread	F05006-2	4
3	Washer, 5/16" SAE Flat	F05011-17	8
4	Washer, 5/16" Split Lock	F05011-13	8
5	Nut, 5/16-18 Hex	F05010-17	6
6	Bolt, 5/16-18 x 2" Hex Head Full Thread	F05006-13	2

6**Debarker Parts***Blade Motor Assembly*

7	Bracket Weldment, Debarker Blade Motor Adjustable	023622	1	
8	Plate, Debarker Blade Motor Mount	023620	1	
9	Bolt, 5/16-18 x 3/4" Hex Head Grade 2	F05006-5	4	
10	Horn, Debarker On Warning	021137	1	
11	Screw, #4-40 x 1/2" Slotted Head	F05004-14	2	
12	Washer, #4 Split Lock	F05011-21	2	
13	Nut, #4-40 Hex	F05010-43	2	
14	Decal, Disconnect Motor Leads Warning	024431	1	
15	Blade/Mandrel Parts (See Section 6.7)			

6.7 Blade Housing Assembly

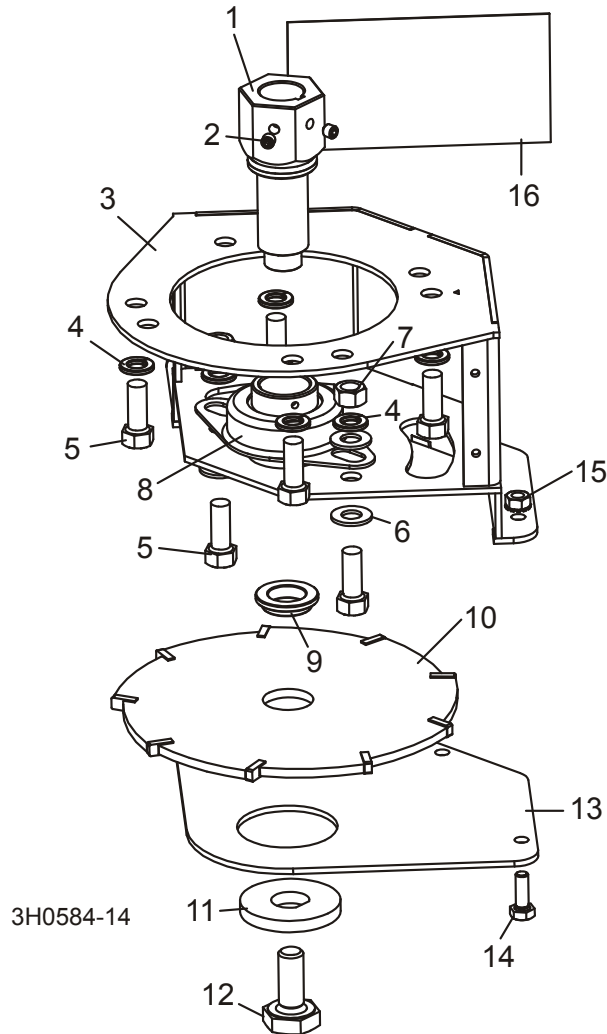

REF	DESCRIPTION (◆ Indicates Parts Available In Assemblies Only)	PART #	QTY.
1	MANDREL, DEBARKER BLADE (7/8" DIA.)	016122	1
2	SCREW, 1/4-28 X 1/4" CUP POINT SOCKET SET	F05005-105	2
3	HOUSING WELDMENT, DEBARKER BLADE	023628	1
4	WASHER, 3/8" SPLIT LOCK	F05011-4	6
5	BOLT, 3/8-16 X 1" HEX HEAD	F05007-7	6
6	WASHER, 3/8" SAE FLAT	F05011-3	4
7	NUT, 3/8-16 HEX	F05010-1	2
8	BEARING, 1" FLANGED MOUNT	023541	1
9	BUSHING, DEBARKER BLADE SPACER	023632	1

6**Debarker Parts***Blade Housing Assembly*

10	BLADE, DEBARKER 7" DIA.	021236	1	
	BLADE, DEBARKER 7" DIA. W/1/2" INSERTS (OPTIONAL - PURCHASED SEPARATELY)	065852	1	
11	WASHER, DEBARKER BLADE LOCK	023737	1	
12	BOLT, 1/2-20 X 1 1/4" HEX HEAD SPECIAL	023547	1	
13	PLATE, DEBARKER BLADE HOUSING BOTTOM	023629	1	
14	BOLT, 1/4-20 X 3/4" HEX HEAD FULL THREAD	F05005-1	3	
15	NUT, 1/4-20 SELF-LOCKING HEX	F05010-9	3	
16	DECAL, DEBARKER HORN DANGER	021172	1	

6.8 Spring Rod Assembly

Rev. B.00+

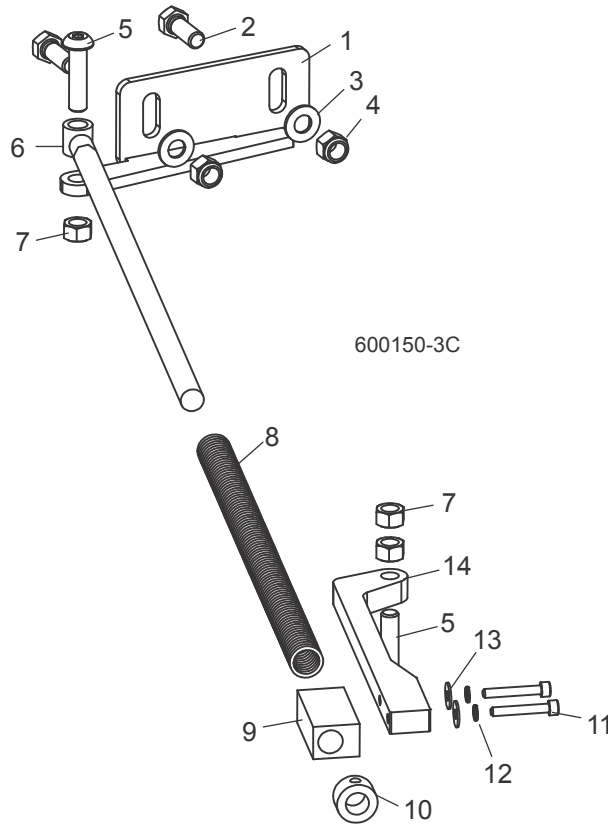

REF	DESCRIPTION (◆ Indicates Parts Available In Assemblies Only)	PART #	QTY.	
1	BRACKET, SPRING ROD MOUNT	045858	1	
2	BOLT, 3/8-16 X 1" HEX HEAD GRADE 5	F05007-87	2	
3	WASHER, 3/8" SAE FLAT	F05011-3	2	
4	NUT, 3/8-16 HEX NYLON LOCK	F05010-10	2	
5	BOLT, 3/8-16 X 1 1/4" SOCKET HEAD	F05007-150 ¹	2	
6	ROD WELDMENT, LT60 DEBARKER SPRING	045852 ²	1	
7	NUT, 3/8-16 HEX LOCK	F05010-25	3	
8	SPRING, .72" OD X 19 1/2" X .08 WIRE	023631	1	
9	BLOCK, SPRING ROD SLIDE	045854 ³	1	
10	COLLAR, 1/2" SHAFT	014820 ⁴	1	
11	BOLT, #10-24 X 1 1/4" SOCKET HEAD	F05004-31 ⁵	2	
12	WASHER, #10 SPLIT LOCK	F05011-20 ³	2	

6 Debarker Parts

Spring Rod Assembly

13	WASHER, #10 SAE FLAT	F05011-18 ³	2	
14	ARM, SLIDE BLOCK MOUNT	046064 ³	1	

¹ Part corrected 12/08 (was F05007-196).

² Rod material changed to chrome to reduce wear and improve sliding performance (Rev. B.03).

³ Grease Fitting P04108 removed 11/06. Lubricate spring rod daily with Automatic Transmission Fluid (ATF) such as Dexron III. Slide Block 045854 modified to improve durability. Mount Arm 046064 modified to relocate grease fitting to avoid interference with spring. Straight Grease Fitting P05060 replaced with 90° Grease Fitting P04108. Fasteners F05004-19, F05011-20 & F05011-18 replace F05004-43 to accommodate thicker slide block (Rev. B.01). See [Form #1161](#) for retrofit instructions.

⁴ Replaces P22315 originally supplied before 5/04 (duplicate parts).

⁵ Socket Head Bolts F05004-31 replace Hex Head Bolts F05004-19 used prior to Rev. B.02 to improve durability.

6.9 Debarker Control Assembly

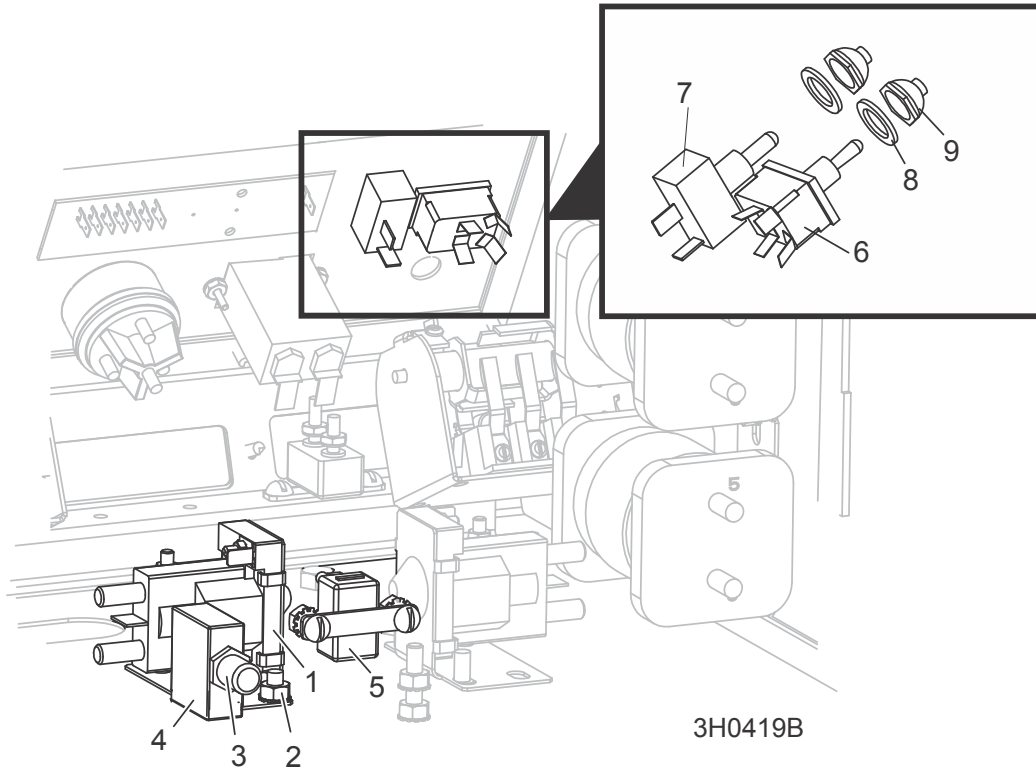

REF	DESCRIPTION (◆ Indicates Parts Available In Assemblies Only)	PART #	QTY.	
	CONTROL ASSEMBLY, DEBARKER (NON-REMOTE)	023676	1	
	CONTROL ASSEMBLY, DEBARKER (REMOTE)	023677	1	
1	Solenoid Kit, Accessory	016372 ¹	1	
	Solenoid, 100A 12V Cont. Duty GND	P10449	1	◆
	Diode Assembly, Solenoid Coil Chassis GND	015426	1	
2	Nut, 1/4-20 Self Locking	F05010-9	2	
3	Boot, Circuit Breaker	021253	1	
4	Breaker, 70 Amp Manual Reset Panel Mount	015527	1	
5	Breaker, 15 Amp Manual Reset	E20430	1	
6	Switch, DPDT Toggle Return Center Screw Terminal	024200	1	
7	Switch, SPST Toggle Quick Connect	P03027	1	
8	Washer, 1/2 x 3/4 x 1/16" Nylon	P05251-1	2	
9	Boot, Toggle Switch	P02575	2	

¹ Solenoid Kit 016372 replaces Solenoid P10449. Kit includes solenoid and replacement instructions. Diode Wire Assembly 015426 added to Solenoid Kit 016372 (8/04).

INDEX

A

alignment 3-1

E

electrical information 5-1
 component list 5-3
 symbol diagram (non-remote) 5-1
 symbol diagram (remote) 5-2
 wiring diagrams (non-remote) 5-4
 wiring diagrams (remote) 5-7
 wiring diagrams (wireless) 5-13

I

installation 2-1
 control components (remote) 2-16
 control components (standard) 2-9
 debarker 2-2

M

maintenance 4-6

O

operation 4-4
 control overview 4-2
 locking pin 4-1

R

replacement parts 6-1
 blade housing 6-10
 blade motor & horn 6-8
 control 6-14
 frame 6-2, 6-4
 in/out motor 6-6
 mechanical assembly 6-1
 spring arm 6-12

S

safety 1-1
 installation & maintenance 1-1
 operation & towing 1-2

T

troubleshooting 4-8
