

G20 Engine

Safety, Operation, Maintenance & Parts Manual

1982 LT40

rev. A0 - Q



Safety is our #1 concern! Read and understand all safety information and instructions before operating, setting up or maintaining this machine.

December 1996

Form #664

Table of Contents

Section-Page

SECTION 1	SAFETY & GENERAL INFORMATION	1-1
1.1	Refueling	1-1
1.2	Engine Operation.....	1-1
1.3	Battery Handling	1-2
SECTION 2	OPERATION	2-1
SECTION 3	MAINTENANCE	3-1
3.1	Air Filter & Pre-Cleaner.....	3-2
3.2	Engine Oil & Filter.....	3-3
3.3	Air Cooling System.....	3-4
3.4	Fuel Filter	3-5
3.5	Battery	3-6
3.6	Alternator Belt.....	3-7
3.7	Drive Belt Adjustment.....	3-8
3.8	Miscellaneous Maintenance	3-9
SECTION 4	REPLACEMENT PARTS	4-1
4.1	How To Use The Parts List.....	4-1
4.2	Sample Assembly	4-1
4.3	Fuel Tank/Tray Assembly	4-2
4.4	Motor Mount Assembly	4-4
4.5	Engine Assembly (Onan P220G).....	4-6
	<i>LT40 Rev. P - Q</i>	
4.6	Engine Assembly (Onan B48G).....	4-9
	<i>LT40 Rev. AO - N</i>	
4.7	Alternator Assembly (Onan P220G).....	4-12
	<i>LT40 Rev P - Q Retrofit</i>	
4.8	Alternator Assembly (Onan B48G).....	4-14
	<i>LT40 Rev AO - N Retrofit</i>	
SECTION 5	ELECTRICAL INFORMATION	5-1
5.1	Electrical Symbol Diagram, LT40 G20.....	5-1
5.2	Electrical Components, LT40 G20.....	5-2
5.3	Battery Specifications, LT40 G20.....	5-3
5.4	Wiring Diagram, LT40 G20.....	5-4

SECTION 1 SAFETY & GENERAL INFORMATION



This symbol calls your attention to instructions concerning your personal safety. Be sure to observe and follow these instructions. This symbol accompanies a signal word. The word **DANGER** refers to hazards that can cause death or serious, irreversible personal injury. The word **WARNING** suggests a safety hazard that can cause personal injury. **CAUTION** refers to hazards that can cause damage to the equipment or property only.

Read all safety instructions before operating this equipment and observe all safety warnings! Read the manufacturer's operation manual and observe any additional safety warnings applicable to the specific make and model you have purchased.

1.1 Refueling



WARNING! Store gasoline away from sawdust and other flammable materials.

WARNING! Do not store gasoline near hot or burning materials.

WARNING! Do not smoke near gasoline storage tank or during refueling.

1.2 Engine Operation



DANGER! Do not operate engine in enclosed areas. Carbon Monoxide poisoning may occur.

DANGER! Do not operate engine without proper and operational spark arrester/muffler.



WARNING! The engine exhaust from this product contains chemicals known to the State of California to cause cancer, birth defects or other reproductive harm.

1.3 Battery Handling



WARNING! Batteries can explode when charging or boosting. Always wear eye protection.

WARNING! Keep cigarettes, flames or sparks away from battery.

WARNING! Charge the battery in a well-ventilated area. Do not attempt to charge a frozen battery.

SECTION 2 OPERATION

2.1 Starting The Engine

To start the engine:

Turn the key switch on the control panel to the START position and release.

If the engine needs choking to start, pull the choke wire out until the engine starts. Push the choke wire in after the engine starts.

For more information, see the engine manufacturer's operation manual.

If the fuel tank was recently filled or replaced, squeeze the primer bulb once or twice before trying to start the engine. **NOTE:** If pumping problems are experienced, make sure the out-flow end of the hose line is connected to the fuel pump. If pumping problems are still experienced, hold the primer bulb in a vertical position while squeezing. This allows the fuel check valve to operate properly.



WARNING! Do not start the engine when the clutch/brake lever is in the engaged (down) position. Always be sure the blade is disengaged and all persons are away from the blade before starting the engine.

WARNING! Make sure the carriage fwd/rev switch is in the neutral position before turning the key switch to the ON or ACC position. This will prevent unintended carriage movement.

2 **Operation** *Starting The Engine*

SECTION 3 MAINTENANCE



IMPORTANT! The Wood-Mizer maintenance schedule takes into account the specific use of engines in the Wood-Mizer sawmill. Therefore, the schedule may require certain procedures be performed at different time intervals than found in the engine manufacturer's manuals. Refer to the manufacturer's manual if you need more information on how to perform a procedure or on the engine itself.



This symbol identifies the interval (hours of operation) which each maintenance procedure should be performed. "AR" signifies maintenance procedures which should be performed as required.

3.1 Air Filter & Pre-Cleaner

4

Service the pre-cleaner every four hours of operation. Service by gently shaking excess sawdust and debris from the foam piece.

8

Clean the air filter (air cleaner element) and pre-cleaner (element wrapper) every eight hours of operation. See the engine manual for further instructions.

200

Replace the air filter (cleaner) every 200 hours of operation.

2000

Replace the pre-cleaner (element wrapper) every 2000 hours of operation.

3.2 Engine Oil & Filter



Check the oil level every 8 hours of operation. Add oil as necessary. See the engine manual for oil viscosity and grade recommendations.



IMPORTANT! During initial break-in, change the oil and the oil filter after the first 5 hours and every 50 hours thereafter. Continue to check oil level every 8 hours of operation and refill as necessary.



3.3 Air Cooling System



Wash the engine or brush off sawdust and debris every 50 hours of operation. Clean the spark arresters, breather pipe, cylinder head and cylinder cooling fins. Remove any dust, dirt or oil. See engine manual for further instructions.

3.4 Fuel Filter



Replace the fuel filter every 100 hours of operation.

3.5 Battery



Check the battery electrolyte level every 50 hours of operation. See manufacturer's manual for instructions.



WARNING! Batteries contain explosive gases. Always wear eye protection and keep face away when charging or boosting battery. Charge battery in well-ventilated area. Keep battery away from hot or burning materials. Avoid spilling electrolyte when handling.

3.6 Alternator Belt

NOTE: External alternators were added to Onan engines after 4/89. Retrofit kits are available so the alternator can be fitted to Onan engines on sawmills built before 4/89. Retrofitting the engine with the external alternator is recommended for hydraulic sawmills or sawmills operating in environments where it is difficult to keep the battery charged.

Adjust the alternator belt as needed. Check the alternator belt for tension and wear when the battery is not charging properly or when the alternator belt is squealing. To tighten the belt, remove the belt cover and loosen the adjustment bolt and lock washer. Pivot the alternator away from the motor until the belt has 3/16" (5 mm) deflection with a 5 lb. deflection force. Retighten the adjustment bolt and replace the belt cover.

See Figure 3-1.

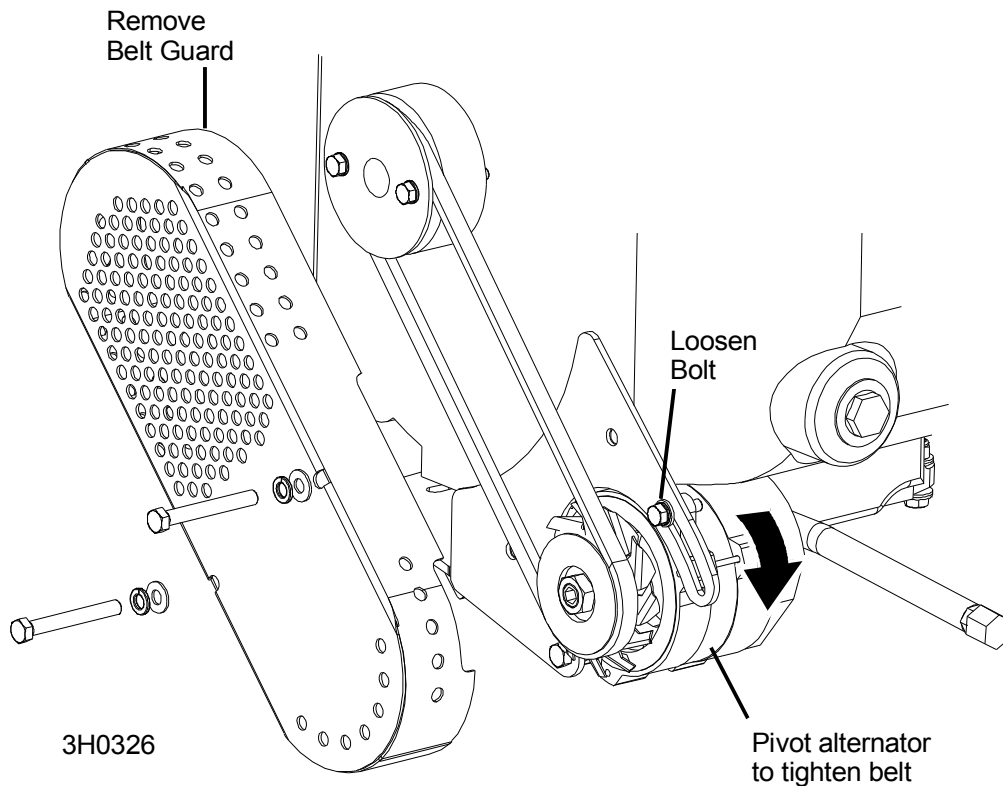

FIG. 3-1

3.7 Drive Belt Adjustment

50

See Figure 3-2. Check the drive belt tension after the first 20 hours, and every 50 hours thereafter. The drive belt should have 7/16" (11 mm) deflection with a 14 lb. deflection force. To adjust the drive belt, loosen the bottom adjustment nut and tighten the top adjustment nut.

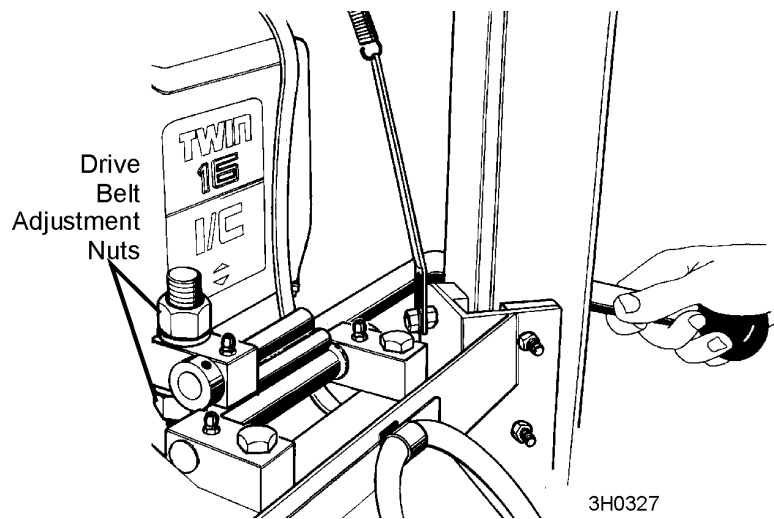

FIG. 3-2

AR

Periodically check all belts for wear. Replace any damaged or worn belts as needed.

3.8 Miscellaneous Maintenance

50

Clean and inspect the spark arresters every 50 hours of operation. Replace if damaged.

100

Inspect the spark plugs every 100 hour of operation. Remove any deposits and adjust gap if necessary. See engine manual for further information.

100

B48 models only: Check breaker points every 100 hours of operation.

200

B48 models only: Replace the points and condensor every 200 hours of operation. See engine manual for further information.

200

B48 models only: Adjust the valve clearance every 200 hours of operation. See engine manual for further details.

400

B48 models only: Clean carbon and lead deposits from the cylinder head every 400 hours of operation. See engine manual for further details.

1000

P220 models only: Adjust the valve clearance every 1000 hours of operation. See engine manual for further details.

1000

P220 models only: Clean carbon and lead deposits from the cylinder head every 1000 hours of operation. See engine manual for further details.

SECTION 4 REPLACEMENT PARTS

4.1 How To Use The Parts List

- Use the table of contents or the index to locate the assembly that contains the part you need.
- Go to the appropriate section and locate the part in the illustration.
- Use the number pointing to the part to locate the correct part number and description in the table.
- Parts shown indented under another part are included with that part.
- Parts marked with a diamond (◆) are only available in the assembly listed above the part.

See the sample table below. Sample Part #A01111 includes part F02222-2 and subassembly A03333. Subassembly A03333 includes part S04444-4 and subassembly K05555. The diamond (◆) indicates that S04444-4 is not available except in subassembly A03333. Subassembly K05555 includes parts M06666 and F07777-77. The diamond (◆) indicates M06666 is not available except in subassembly K05555.

4.2 Sample Assembly				
REF	DESCRIPTION (◆ Indicates Parts Available In Assemblies Only)	PART #	QTY.	
	SAMPLE ASSEMBLY, COMPLETE (INCLUDES ALL INDENTED PARTS BELOW)	A01111	1	
1	Sample Part	F02222-22	1	
	Sample Subassembly (Includes All Indented Parts Below)	A03333	1	
2	Sample Part (◆ Indicates Part Is Only Available With A03333)	S04444-4	1	◆
	Sample Subassembly (Includes All Indented Parts Below)	K05555	1	
3	Sample Part (◆ Indicates Part Is Only Available With K05555)	M06666	2	◆
4	Sample Part	F07777-77	1	

To Order Parts:

- From the continental U.S., call **1-800-525-8100** to order parts. Have your customer number, vehicle identification number, and part numbers ready when you call.
- From other international locations, contact the Wood-Mizer distributor in your area for parts.

4

Replacement Parts

Fuel Tank/Tray Assembly

4.3 Fuel Tank/Tray Assembly				
REF	DESCRIPTION (◆ Indicates Parts Available In Assemblies Only)	PART #	QTY.	
	TANK ASSEMBLY, 3-GALLON RED GASOLINE	A07578 ¹	1	◆
1	Tank, 3-Gallon Red Fuel	P07463 ¹	1	◆
2	Fitting, Male Disconnect	P07830 ²	1	◆
	TRAY ASSEMBLY, FUEL TANK	A07438 ³	1	◆
3	Tray, Fuel Tank	S07515 ³	1	◆
4	Strap, 20" Rubber	P11668 ⁴	2	
5	Bolt, 1/4-20 X 1" Carriage Head	F05005-34	2	
6	Nut, 1/4-20 Hex Lock	F05010-21	2	
	HOSE, FUEL LINE WITH PRIMER BULB	014497 ⁵	1	
	Bulb Kit, Fuel Primer Replacement	014496 ⁵	1	
7	Bulb, Fuel Primer	014481	1	◆
	Clamp, 7/32 - 1/2 Hose	P649 ⁵	2	
	Instruction Sheet, Fuel Primer Bulb Replacement	014496-590	1	
	Hose, 1/4" ID Fuel	P642 ⁵	6.5 Ft	
	Clamp, 7/32 - 1/2 Hose	P649 ⁵	2	
8	FITTING, 1/4" NPT FEMALE DISCONNECT	P07831 ²	1	◆
9	O-RING KIT, METAL DISCONNECT FITTINGS	P07832 ⁶	1	

¹ 3-Gallon fuel tank A07578 replaced by A12285 5-Gallon tank. IUpgrade requires two P11258 24" rubber straps and one P12176 Male Disconnect Fitting sold separately. Requires modification of existing tray or replacement with larger tank tray A09692.

² Metal Disconnect fittings P07830 and P07831 replaced with plastic fittings P12175 & P12176. Replacement of fittings also requires qty. 1 hose clamp (P649).

³ A07438 tray assembly obsolete. Use A09692 tray assembly. A09692 also required if tank upgraded to 5-Gallon tank. Use existing rubber straps or purchase two P11668 20" straps sold separately so secure original Unistream 3-Gallon tank.

⁴ P11668 20" rubber strap replaces M07464 strap originally supplied.

⁵ Fuel Line Assembly w/Primer Bulb replaces P10083 originally supplied. UV-resistant primer bulb kit 014496 available separately. Fuel Line P642 replaces R01890-1 originally supplied. Hose Clamp P649 replaces plastic clamp P12374 previously supplied.

⁶ Includes O-rings for male and female metal fittings. Fittings may be replaced with plastic fittings P12175 & P12176.

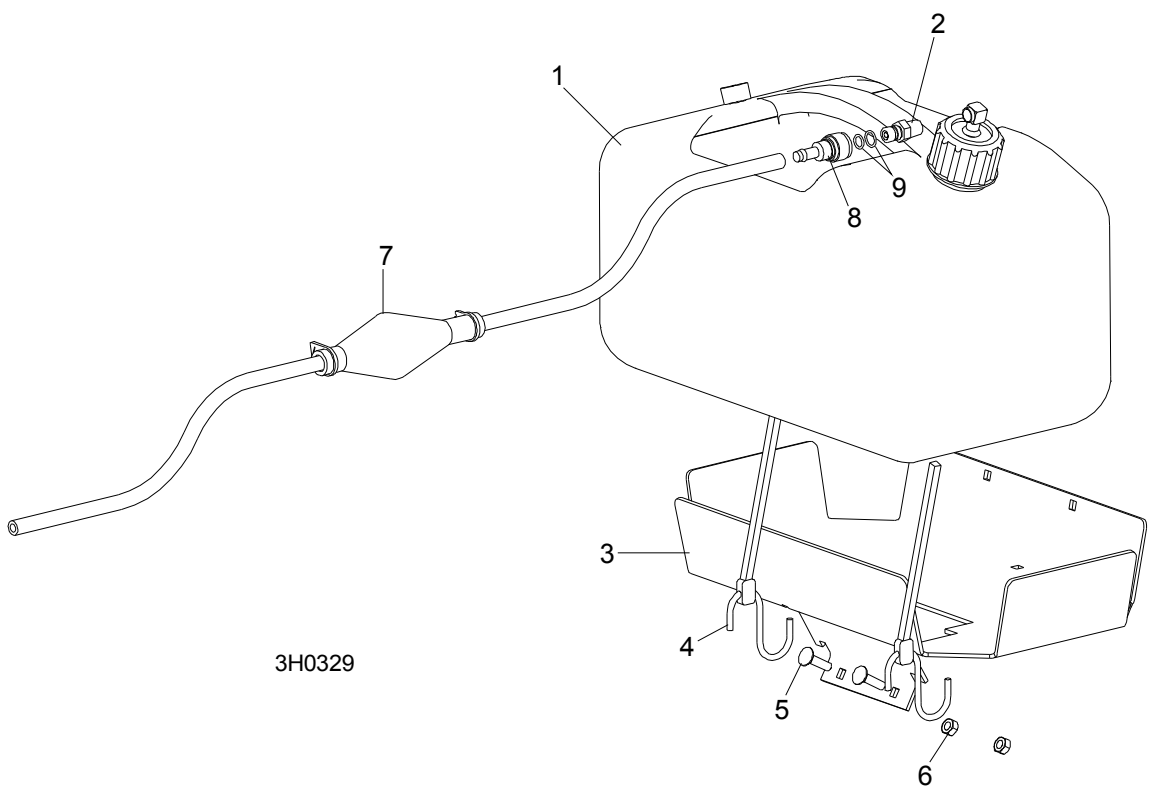

FIG. 4-1

4

Replacement Parts*Motor Mount Assembly*

4.4 Motor Mount Assembly				
REF	DESCRIPTION (◆ Indicates Parts Available In Assemblies Only)	PART #	QTY.	
1	PLATE, MOTOR MOUNT	W09543 ¹	1	
	BUSHING ASSEMBLY, MOTOR MOUNT PIVOT	A04127 ²	2	◆
2	Bushing, Rubber Motor Mount Pivot	P12164	1	
3	Spacer, Motor Mount Pivot	P05041	1	
4	PLATE, MOTOR MOUNT PIVOT BUSHING	S04403	2	
5	BOLT, 5/16-18 X 2 1/2" 'U'	P05039	2	
6	NUT, 5/16-18 HEX LOCK	F05010-6	2	
7	NUT, 1/2-13 NYLON LOCK	F05010-8	2	
8	PLATE, BRAKE STRAP CLAMP	S04195	1	
9	BOLT, 1/2-13 X 1 1/2" HEX HEAD	F05008-3	2	
10	BRACKET, MOTOR MOUNT HANGER	W05028	1	
11	BRACKET, MOTOR MOUNT ADJUSTABLE CLUTCH	W05025	1	
12	SPACER, MOTOR MOUNT BUSHING	S07396	2	
13	BUSHING, RUBBER MOTOR MOUNT	P05032	2	
14	PLATE, MOTOR MOUNT WASHER	S05031	1	
15	WASHER, 1/2" SPLIT LOCK	F05011-9	2	
16	NUT, 1/2-13 HEX LOCK	F05010-3	2	
17	GUARD, ENGINE BRUSH	W09498 ³	1	

¹ Replaces W04404 & W04388 Motor Mount originally used with B48 Onan engine.

² A04127 no longer available. Purchase individual component parts P12164 and P05041.

³ Used on engines without external alternator before 4/89.

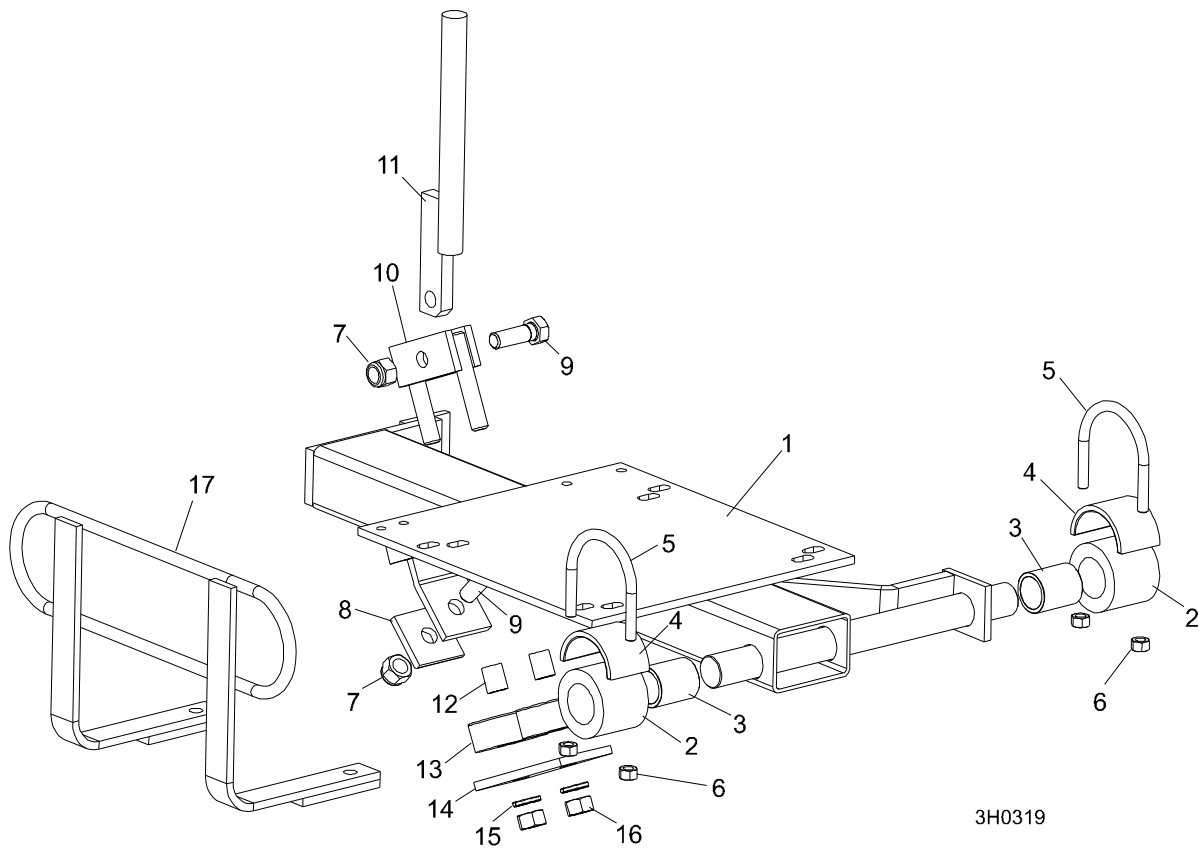

FIG. 4-2

4

Replacement Parts

Engine Assembly (Onan P220G)

4.5 Engine Assembly (Onan P220G)				
LT40		Rev. P - Q		
REF	DESCRIPTION (◆ Indicates Parts Available In Assemblies Only)	PART #	QTY.	
	ENGINE ASSEMBLY, 20HP ONAN P220G	A09500 ¹	1	◆
1	Engine, 20Hp Onan P220G (See Form #202 for complete list of engine parts)	P09499 ¹	1	◆
2	Filter, Onan 20/24Hp Air	P07566	1	
3	Pre-Cleaner, Onan 20/24Hp Air	P07961	1	
4	Plug, Onan Spark (Champion #RS17YX)	P06819	2	
5	Filter, Onan Oil	P09881 ²	1	
6	Pump, Onan Fuel	P07978	1	
7	Filter, In-Line Fuel	P07570	1	
8	Starter Motor, Onan	P06830	1	
9	Muffler with Spark Arrestor, Double-Manifold	P07833 ³	2	◆
	Bolt, Spark Arrestor Mounting	P09458 ³	2	◆
10	Clamp, 20hp Onan Muffler	P07834 ³	2	◆
11	Manifold, Onan 20Hp Exhaust Left (Shown)	W09019 ³	1	◆
	Manifold, Onan 20hp Exhaust Right	W09020 ³	1	◆
12	Coil, Onan Ignition	055005 ⁴	1	
13	Regulator, Onan 35 Amp	P09679 ⁵	1	
14	Spring, Onan Governor	P04497	1	
	Carburetor Kit, Onan Repair 146-0500	P06826 ⁶	1	
	Bracket Assembly, Onan P220 Throttle Mount	A07477	1	
15	Bracket, Throttle Adjustment	S07479	1	◆
16	Bracket, Throttle Mount	S07478	1	◆
17	Washer, Throttle Bracket	S07481	2	◆
18	Bolt, 1/4-20 x 3/4" Hex Head	F05005-1	1	
19	Nut, 1/4-20 Hex Lock	F05010-21	2	
20	Spacer, Throttle Bracket	S07480	1	
21	Nut, #10-24 Hex Self-Locking	F05010-14	1	
22	Screw, #10-24 x 1" Socket Head Cap	F05004-2	1	
23	Spring, Onan Throttle	P07482	1	
24	Link, Onan Throttle	S09539	1	
25	Wire, Onan Choke	S07485	1	
26	Hose, 7" Oil Drain	P10082 ⁷	1	
27	Cap, Oil Drain 3/8" Pipe	P04332	1	
	Oil, 10W30 Type CD	L04869-1	.5 Gal	◆
28	Pulley, 2-Groove 2BK34H Motor	P04853	1	
29	Key, 1/4" x 1/4" x 1 11/16"	S04124 ⁸	1	
30	Bushing, 1 1/8" Split Taper	P04306	1	
31	BELT, 2BX70 DRIVE	P04857-2 ⁹	1	

32	BOLT, 3/8-16 X 2" HEX HEAD GRADE 2	F05007-16	2	
33	BOLT, 3/8-16 X 1 1/2" HEX HEAD	F05007-3	2	
34	WASHER, 3/8" SAE FLAT	F05011-3	8	
35	NUT, 3/8-16 HEX NYLON LOCK	F05010-10	4	

¹ Onan P224G engine replaces P220G originally supplied. Replace engine with A10184 24hp engine assembly (requires external alternator kit K10024).

² P09881 oil filter replaces P07569 originally supplied. New filter includes hex cap for easier filter changes.

³ Muffler parts obsolete (discontinued by vendor). Upgrade to single-manifold type using kit K12747 which includes muffler P12505, spark arrestor P12506 and exhaust tube P12507.

⁴ Coil kit P06827 no longer available from vendor. If replacing original coil, order mount parts: Screw 055000, Nut 055001, Screw 055002, Clamp 055003 & Bracket 055004 in addition to Coil 055005. If coil is mounted on top of manifold, order coil 055005 only.

⁵ Regulator replaced with external alternator after 4/89. Engine may be retrofitted with alternator to eliminate battery charging problems. [See Section 4.7.](#)

⁶ Includes screw and plug package, gasket package, float valve, idle adjust needle and spring, mounting gaskets, and idle limit cap.

⁷ P10082 flexible oil drain replaces M04935 pipe drain originally supplied until 7/89.

⁸ 1-11/16" key replaces 1 1/4" or 2" key originally supplied.

⁹ One double belt P04857-2 replaces two single belts P04857 originally supplied.

4 Replacement Parts Engine Assembly (Onan P220G)

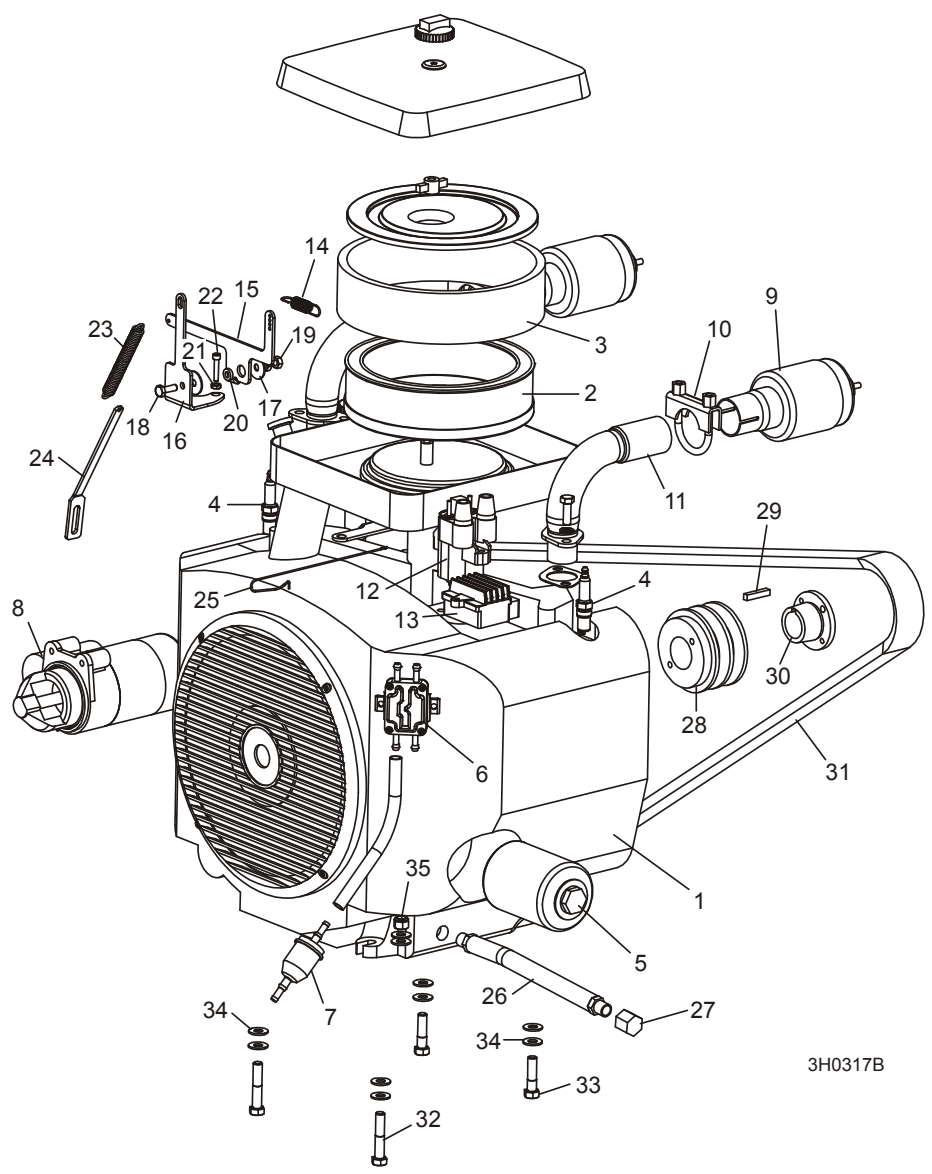

FIG. 4-3

4.6 Engine Assembly (Onan B48G)				
<i>LT40</i>		<i>Rev. AO - N</i>		
REF	DESCRIPTION (◆ Indicates Parts Available In Assemblies Only)	PART #	QTY.	◆
	ENGINE ASSEMBLY, 20HP ONAN B48G	A07455 ¹	1	◆
1	Engine, 20Hp Onan B48G (See Form #202 for complete list of engine parts)	P04656 ¹	1	◆
2	Filter, Onan 20/24Hp Air	P07566	1	
3	Pre-Cleaner, Onan 20/24Hp Air	P07961	1	
4	Plug, Onan Spark (Champion #RS17YX)	P06819	2	
5	Filter, Onan Oil	P09881 ²	1	
6	Pump, Onan Fuel	P07978	1	
7	Filter, In-Line Fuel	P07570	1	
8	Muffler with Spark Arrester, Double-Manifold	P07833 ³	2	◆
	Bolt, Spark Arrestor Mounting	P09458 ³	2	◆
9	Clamp, 20hp Onan Muffler	P07834 ³	2	◆
10	Manifold, Onan 20Hp Exhaust Left (Shown)	W09019 ³	1	◆
	Manifold, Onan 20hp Exhaust Right	W09020 ³	1	◆
11	Coil, Onan Ignition	P10358	1	
12	Regulator, Onan 20 Amp	P07932 ⁴	1	
13	Spring, Onan Governor	P04497	1	
	Bracket Assembly, Onan P220 Throttle Mount	A07477	1	
14	Bracket, Throttle Adjustment	S07479	1	◆
15	Bracket, Throttle Mount	S07478	1	◆
16	Washer, Throttle Bracket	S07481	2	◆
17	Bolt, 1/4-20 x 3/4" Hex Head	F05005-1	1	
18	Nut, 1/4-20 Hex Lock	F05010-21	2	
19	Spacer, Throttle Bracket	S07480	1	
20	Nut, #10-24 Hex Self-Locking	F05010-14	1	
21	Screw, #10-24 x 1" Socket Head Cap	F05004-2	1	
22	Spring, Onan Throttle	P07482	1	
23	Link, Onan Throttle	S09539	1	
24	Wire, Onan Choke	S07485	1	
25	Hose, 7" Oil Drain	P10082 ⁵	1	
26	Cap, Oil Drain 3/8" Pipe	P04332	1	
	Oil, 10W30 Type CD	L04869-1	.5 Gal	◆
27	Pulley, 2-Groove 2BK34H Motor	P04853	1	
28	Key, 1/4" x 1/4" x 1 11/16"	S04124 ⁶	1	
29	Bushing, 1 1/8" Split Taper	P04306	1	
30	BELT, 2BX70 DRIVE	P04857-2 ⁷	1	
31	BOLT, 3/8-16 X 2" HEX HEAD GRADE 2	F05007-16	2	
32	BOLT, 3/8-16 X 1 1/2" HEX HEAD	F05007-3	2	
33	WASHER, 3/8" SAE FLAT	F05011-3	8	

4

Replacement Parts

Engine Assembly (Onan B48G)

34	NUT, 3/8-16 HEX NYLON LOCK	F05010-10	4	
----	----------------------------	-----------	---	--

¹ Onan P224G engine replaces B48G originally supplied. Replace engine with A10184 24hp engine assembly (requires external alternator kit K10024).

² P09881 oil filter replaces P07569 originally supplied. New filter includes hex cap for easier filter changes.

³ Muffler parts obsolete (discontinued by vendor). Upgrade to single-manifold type using kit K12747 which includes muffler P12505, spark arrestor P12506 and exhaust tube P12507.

⁴ Regulator replaced with external alternator after 4/89. Engine may be retrofitted with alternator to eliminate battery charging problems. [See Section 4.7.](#)

⁵ P10082 flexible oil drain replaces M04935 pipe drain originally supplied until 7/89.

⁶ 1-11/16" key replaces 1 1/4" or 2" key originally supplied.

⁷ One double belt P04857-2 replaces two single belts P04857 originally supplied.

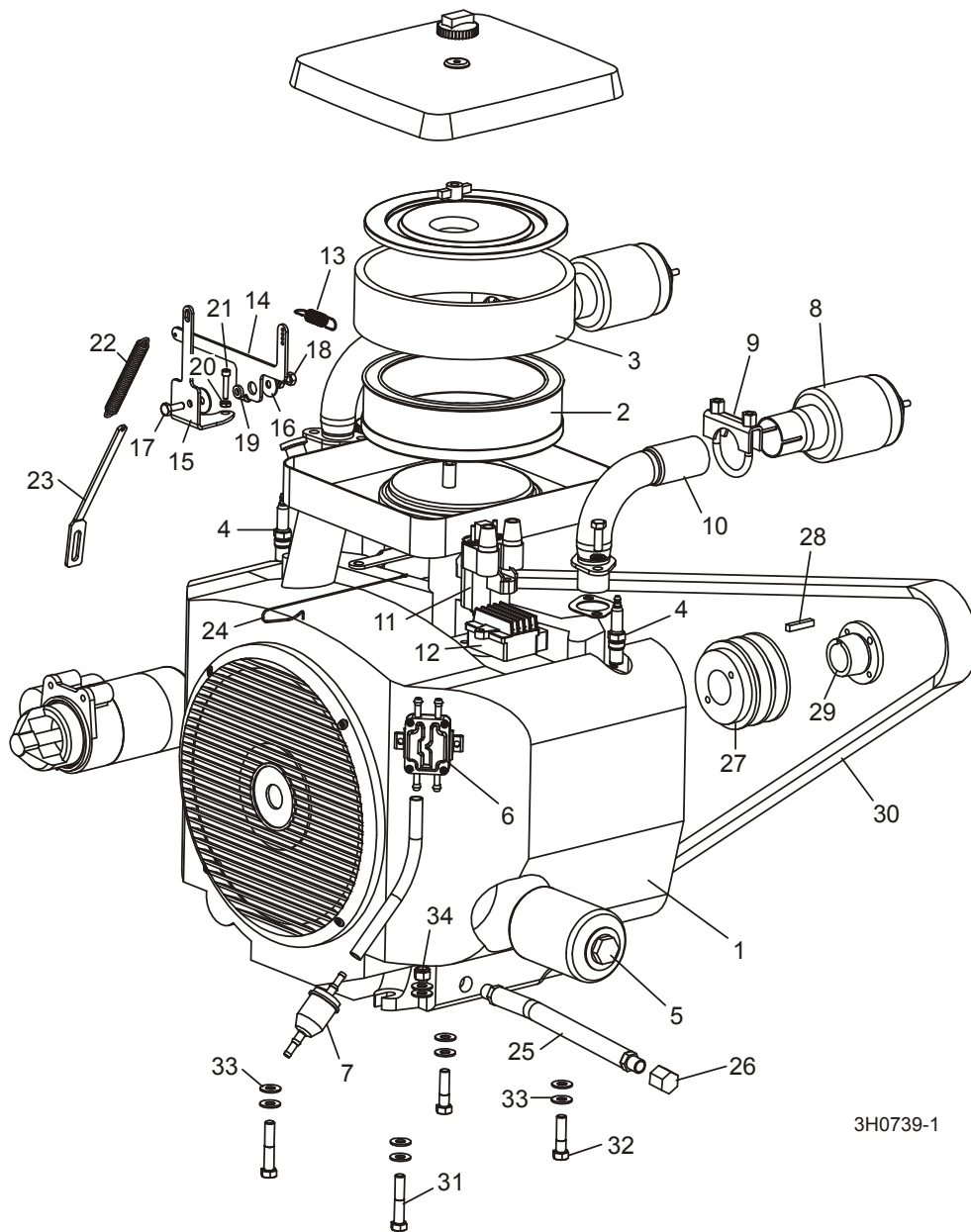

FIG. 4-4

4

Replacement Parts

Alternator Assembly (Onan P220G)

4.7 Alternator Assembly (Onan P220G)				
LT40		Rev P - Q Retrofit		
REF	DESCRIPTION (◆ Indicates Parts Available In Assemblies Only)	PART #	QTY.	
	ALTERNATOR RETROFIT, ONAN P220G	K10024 ¹	1	
	Alternator Assembly, P220G Retrofit	A10036-N	1	◆
1	Pulley, Engine Alternator Drive	S10021 ²	1	
2	Washer, 5/16" Split Lock	F05011-13	2	
3	Bolt, 5/16-18 x 2 1/2" Hex Head	F05006-10	2	
4	Bracket, Alternator Mount	W10269 ³	1	
	Alternator Kit, 105 Amp W/Brace	K12801 ³	1	
5	Alternator, 105A 12V	050287 ³	1	
6	Bracket, Alternator Brace	W12761 ⁴	1	
7	Bolt, 3/8-16 x 5 1/2" Hex Head Full Thread	F05007-34 ⁴	1	
8	Nut, 3/8-16 Hex Nylon Lock	F05010-10	1	
9	Bolt, M8 X 1.25" X 1" Hex Head Full Thread	F05004-40	1	
10	Washer, 5/16" Split Lock	F05011-13	1	
11	Pulley, Alternator Belt	P03806	1	
12	Bolt, M8 X 1.25" X 1" Hex Head Full Thread	F05004-40	1	
13	Washer, 5/16" Split Lock	F05011-13	1	
14	Washer, 5/16" SAE Flat	F05011-17	1	
15	Belt, 15335 Alternator	P10013	1	
16	Guard, Alternator Belt	W10042	1	
17	Washer, 3/8" SAE Flat	F05011-3	2	
18	Washer, 3/8" Split Lock	F05011-4	2	
19	Bolt, 3/8-16 x 3" Hex Head Full Thread	F05007-1	2	
	Hose, Flexible Oil Drain	P10039	1	
	Harness, Upper Wire	A10034	1	
	Harness, Lower Wire	A10030	1	
	Bag Assembly, Alternator Retrofit	A10152	1	
	Instruction Sheet, Alternator Retrofit	K10024-234	1	
	WIRE ASSEMBLY, 61/105 AMP ALTERNATOR PLUG	015969	1	

¹ Alternator retrofit available for P220 engines before 4/89.

² S10021 replaces S10021-W. Part number change only.

³ 105A Alternator 050287 replaces 61A alternator P03804 originally supplied (no longer available from vendor). Requires replacement of mounting bracket (W10269). Existing brackets can be modified to accept 105A alternator by grinding enough material (approx. 1/16" - 1/8") from the bottom of the mounting plates to clear the larger alternator body.

⁴ Brace added to reinforce alternator after 8/94. 5 1/2" Bolt F05007-34 replaces F05007-1 3/8-16 x 3" Hex Head Bolt.

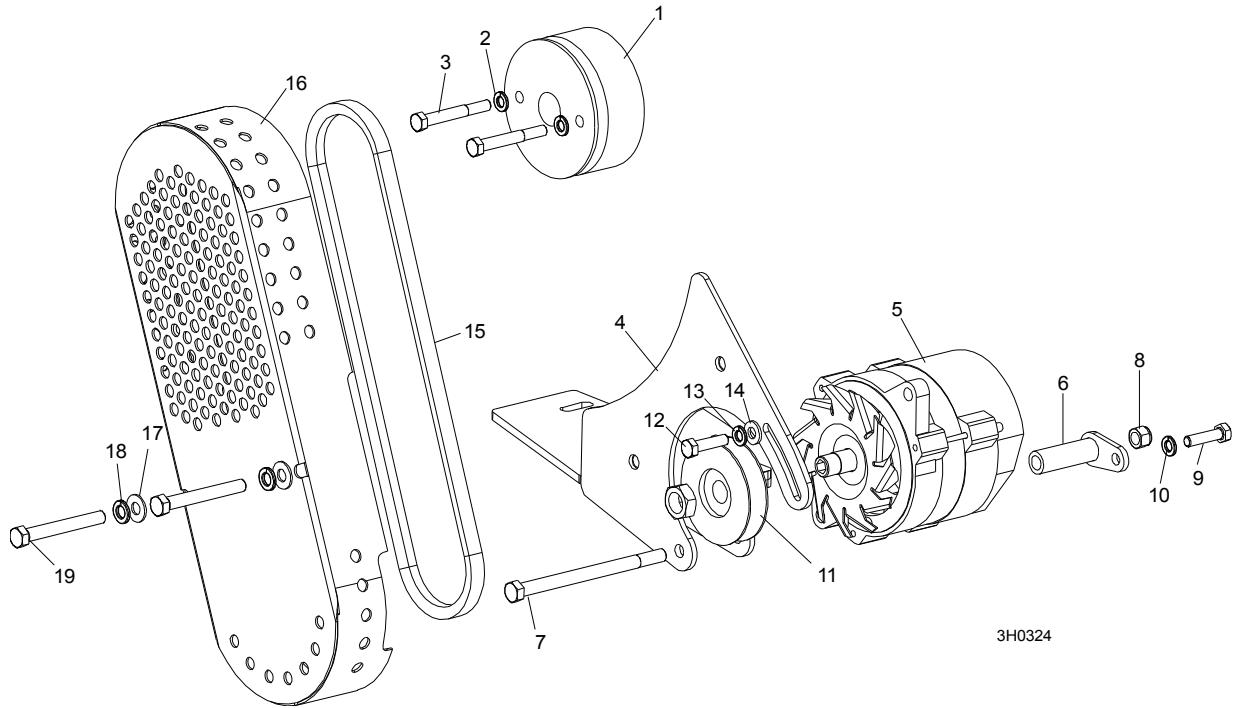

FIG. 4-5

4

Replacement Parts

Alternator Assembly (Onan B48G)

4.8 Alternator Assembly (Onan B48G)				
LT40		Rev AO - N Retrofit		
REF	DESCRIPTION (◆ Indicates Parts Available In Assemblies Only)	PART #	QTY.	
	ALTERNATOR RETROFIT, ONAN B48G	K10025 ¹	1	
	Alternator Assembly, B48G Retrofit	A10037-N	1	◆
1	Pulley, Engine Alternator Drive	S09961 ²	1	
2	Washer, 5/16" Split Lock	F05011-13	2	
3	Bolt, 5/16-18 x 1 1/2" Hex Head	F05006-2	2	
4	Bracket, Alternator Mount	W10023 ³	1	
	Alternator Kit, 105 Amp W/Brace	K12801 ³	1	
5	Alternator, 105A 12V	050287 ³	1	
6	Bracket, Alternator Brace	W12761 ⁴	1	
7	Bolt, 3/8-16 x 5 1/2" Hex Head Full Thread	F05007-34 ⁴	1	
8	Nut, 3/8-16 Hex Nylon Lock	F05010-10	1	
9	Bolt, M8 X 1.25" X 1" Hex Head Full Thread	F05004-40	1	
10	Washer, 5/16" Split Lock	F05011-13	1	
11	Pulley, Alternator Belt	P03806	1	
12	Bolt, M8 X 1.25" X 1" Hex Head Full Thread	F05004-40	1	
13	Washer, 5/16" Split Lock	F05011-13	1	
14	Washer, 5/16" SAE Flat	F05011-17	1	
15	Belt, 15335 Alternator	P10013	1	
16	Guard, Alternator Belt	W09992	1	
17	Washer, 3/8" SAE Flat	F05011-3	2	
18	Washer, 3/8" Split Lock	F05011-4	2	
19	Bolt, 3/8-16 x 3" Hex Head Full Thread	F05007-1	2	
	Hose, Flexible Oil Drain	P10039	1	
	Harness, Upper Wire	A10034	1	
	Harness, Lower Wire	A10030	1	
	Bag Assembly, Alternator Retrofit	A10152	1	
	Instruction Sheet, Alternator Retrofit	K10025-234	1	
	WIRE ASSEMBLY, 61/105 AMP ALTERNATOR PLUG	015969	1	

¹ Alternator retrofit available for B48 engines before 4/89.

² S09961 replaces S09961-W. Part number change only.

³ 105A Alternator 050287 replaces 61A alternator P03804 originally supplied (no longer available from vendor). Requires replacement of mounting bracket (W10023). Existing brackets can be modified to accept 105A alternator by grinding enough material (approx. 1/16" - 1/8") from the bottom of the mounting plates to clear the larger alternator body.

⁴ Brace added to reinforce alternator after 8/94. 5 1/2" Bolt F05007-34 replaces F05007-1 3/8-16 x 3" Hex Head Bolt.

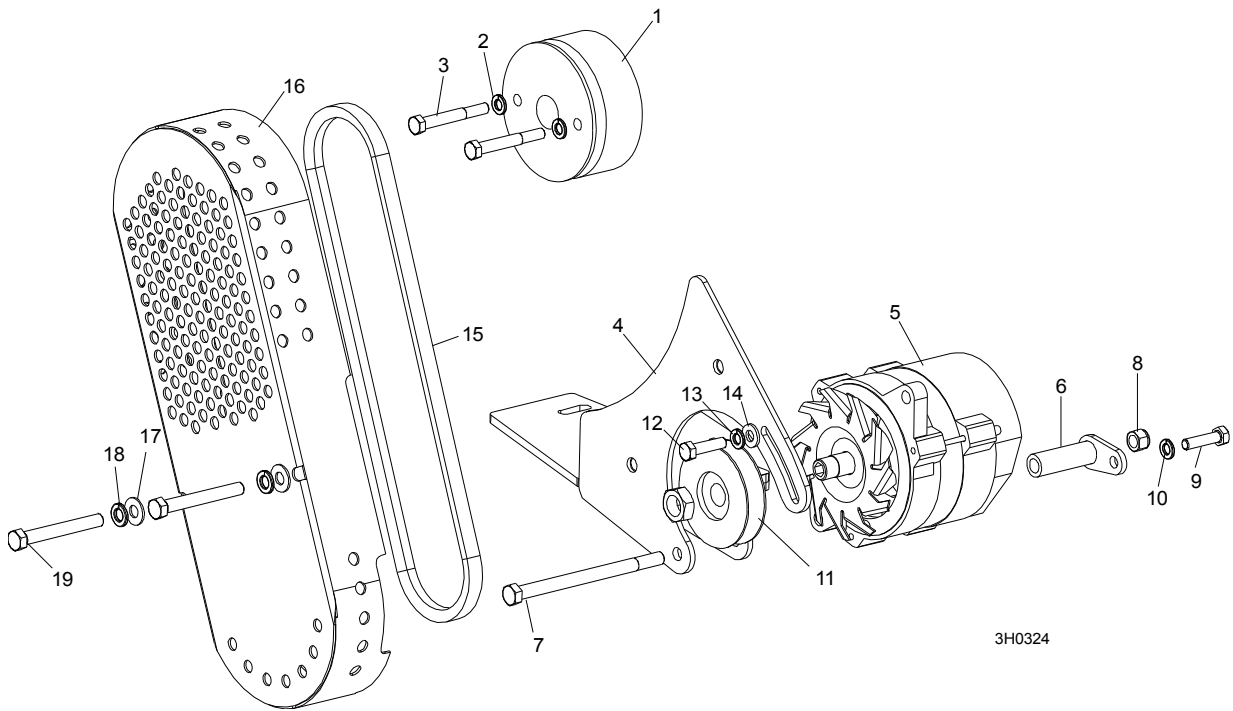

FIG. 4-6

Form #202

Onan Engine Service Parts (● indicates part is applicable to specified model)

Description	WM Part No.	Onan Part No.	18HP P218G	20HP B48G	20HP P220G	24HP T260G	24HP P224G
Cap, Crankcase Breather	P06828	123-0954	●	N/A	●	●	●
Carburetor, Onan	P06825	146-0662	146-659	146-0495 (Spec B-C) 146-0660 (Spec D+)	146-0660	●	●
Carburetor Kit, Onan Repair	P06826	146-0500	● (Spec A-F) 146-0657 (Spec G+)	146-0292 (Spec B-C) 146-0356 (Spec D+)	● (Spec A-F)	●	● (Spec A-F) 146-0657 (Spec G+)
Cleaner, Onan 4C Carburetor	014385	326-5278	●	●	●	●	●
Clip, Onan Linkage #004	P09580	518-0004	●	●	●	●	●
Clip, Onan Linkage #406	P09581	518-0406	●	●	●	●	●
Coil, Onan Ignition	P10358	166-0772	N/A	●	N/A	● (Spec A-E)	N/A
Coil, Onan Ignition (Electronic)	055005 ^a	166-0820	●	N/A	●	● (Spec F+)	●
Condenser, Onan Elec. Ignition	P06820	312-0256	●	N/A	●	312-0255 (Spec F+)	●
Condenser, Kit w/Points	K12503	160-1183/312-0246	N/A	●	N/A	● (Spec A-E)	N/A
Filter, Onan Air	P07566	140-2628-01	●	●	●	●	●
Filter, Onan Air Pre-Cleaning	P07961	140-1496-01	●	●	●	●	●
Filter, Onan Inline Fuel	P07570	149-2206-01	●	●	●	●	●
Filter, Onan Oil	P09881	122-0469	●	●	●	●	●
Gasket Kit, Complete Engine	P06815	168-0191	168-0187	168-0187	168-0187	●	●
Gasket Kit, B48/P218/P220 Decarbon	014629	168-0189	●	●	●	N/A	N/A
Gasket Kit, T260/P224 Decarbon	P06822	168-0190	N/A	N/A	N/A	●	●
Gasket Kit, T260/P224 Valve Adjust	014604	110-3575/154-2219/ 154-2747 (2 ea)	N/A	N/A	N/A	●	●
Jet, P218 High Altitude Carburetor	014630	146-0652	●	N/A	N/A	N/A	N/A
Jet P224 High Altitude Carburetor	014631	146-0695	N/A	N/A	N/A	N/A	●
Jet, Onan Carburetor Idle	P09624	146-0426	●	146-0337	●	●	● (Spec A-G)
Plug, RS17YC Spark	P06819	167-0272	●	●	●	●	●
Pump, Onan Fuel	P07978	149-1982	●	●	●	●	149-2187-02
Regulator, 20 Amp	P07932	191-2106	●	●	●	N/A	N/A
Regulator, 35 Amp	P09679	191-1847	N/A	N/A	N/A	●	N/A
Spring, Onan Governor	P04497	150-1214	●	●	●	N/A	●
Spring, Onan Governor (T260)	014610	150-1831	N/A	N/A	N/A	●	N/A

Spring, Onan Governor Rod	014311	N/A	N/A	N/A	N/A	N/A	●
Spring, Onan Governor Surge	014541	150-1755	N/A	N/A	N/A	150-2550	●
Starter, Onan Engine	P06830	191-1949-04	●	191-1567	●	191-1949-01	●

^a Coil kit P06827 (541-0523) no longer available from vendor. If replacing original coil, order mount parts: Screw 055000, Nut 055001, Screw 055002, Clamp 055003 & Bracket 055004 in addition to Coil 055005. If coil is mounted on top of manifold, order coil 055005 only.

SECTION 5 ELECTRICAL INFORMATION

5.1 Electrical Symbol Diagram, LT40 G20

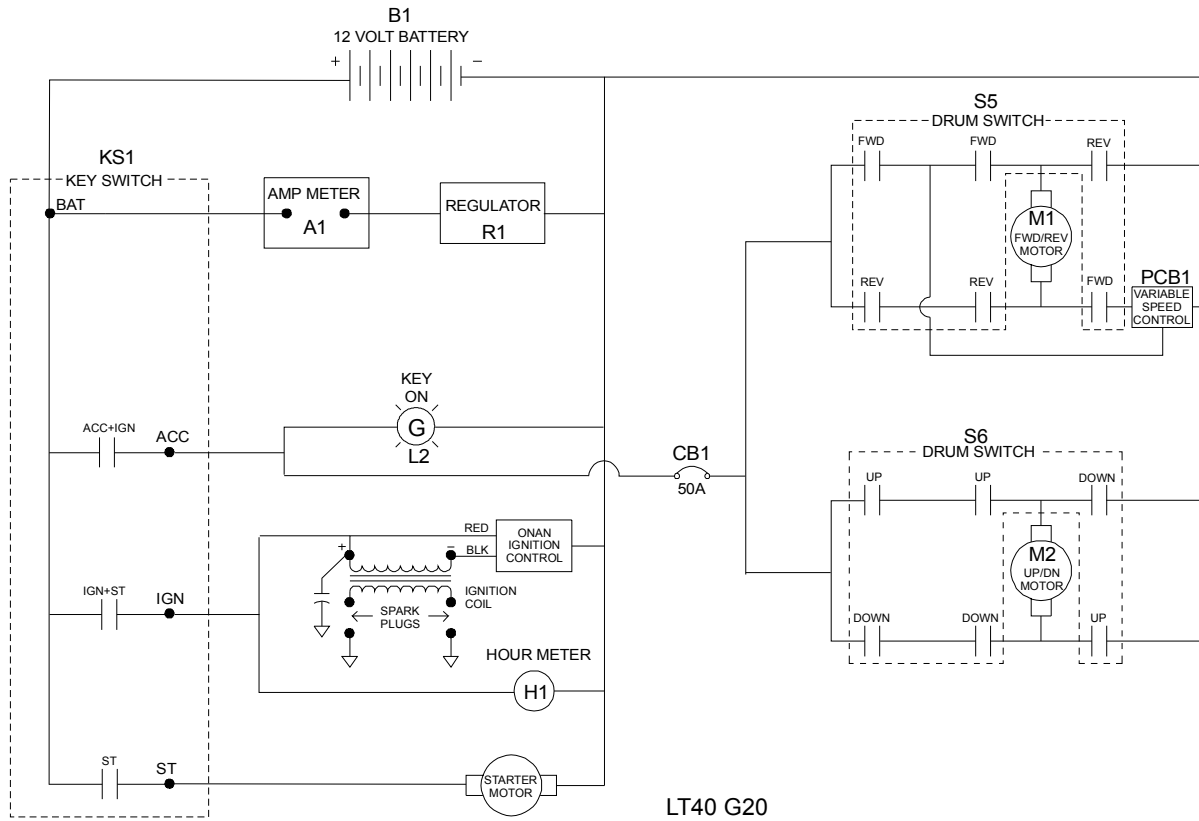

LT40 G20

300102

FIG. 5-1

5.2 Electrical Components, LT40 G20

Component	Manufacturer Part No.	Manufacturer	Wood-Mizer Part No.	Description
A1			P04270	Amp Meter
B1	93ET-DRY	Deka	P04325	Battery, 12 Volt (See Section 5.3)
CB1	30056-50	Cole-Hersee	A04706	Circuit Breaker, 50 Amp, 12 Volt Auto Reset
H1	T40 Series	ENM Corp.	P09631	Hour Meter, 12 Volt, Low Power T40 Series
KS1	121801	General	P04350	Key Switch, 4-position (Accessory, Off, Ignition, Start)
L1	2129	General	P20436	Light, Green Indicator, For Key Switch In Acc Or Ign Position
M1	A07974	Wood-Mizer	A07974	Motor, 12 Volt Power Feed
M2	N/A	Leeson ¹	A04367	Motor, 12 Volt Up/Down
PCB1	A07800-W	Wood-Mizer	A07800-W	Control Assembly, Pre-92 Power Feed (includes items below & S5 Drum Switch)
	A07751	Wood-Mizer	A07751	Circuit Board, Pre-92 Power Feed
	A06963	Wood-Mizer	A06963	Module Assembly, MOSFET Power
	024756	Wood-Mizer	024756	Diode Assembly, Pre-92 Power Feed
	A07793	Wood-Mizer	A07793	Potentiometer, Power Feed
	P06257	Davies Molding	2300CK	Knob, Speed Control
R1	191-1847	Onan	P09679	Regulator, Onan 35 Amp
S5	2601-AG2-S14	Square D	A07799 ²	Drum Switch, Power Feed Fwd/Reverse Motor
S6	2601-AG2-S13	Square D	A11758 ³	Drum Switch, Up/Down Motor

¹ Replaces Leeson motor #S.I. 2917-A (10/01) and Owosso motor #PV-28147Q originally supplied (12/00).

² Replaces M04237 Dayton drum switch originally supplied until 1/91.

³ Replaces A04705 Dayton drum switch w/spring originally supplied until 1/91. Replacement spring P04020 still available for old drum switch.

5.3 Battery Specifications, LT40 G20

Group No.	Type No.	Performance Level		Approximate Weight	Maximum Overall Dimensions		
		Cranking Performance	Reserve Capacity	Wet	Length	Width	Height
3ET	93ET-DRY	500CC	120	49.5 lb. (22.45 kg)	19.25 in. (489 mm)	4.25 in. (108 mm)	9.875 in. (251 mm)

TABLE 5-1

5.4 Wiring Diagram, LT40 G20

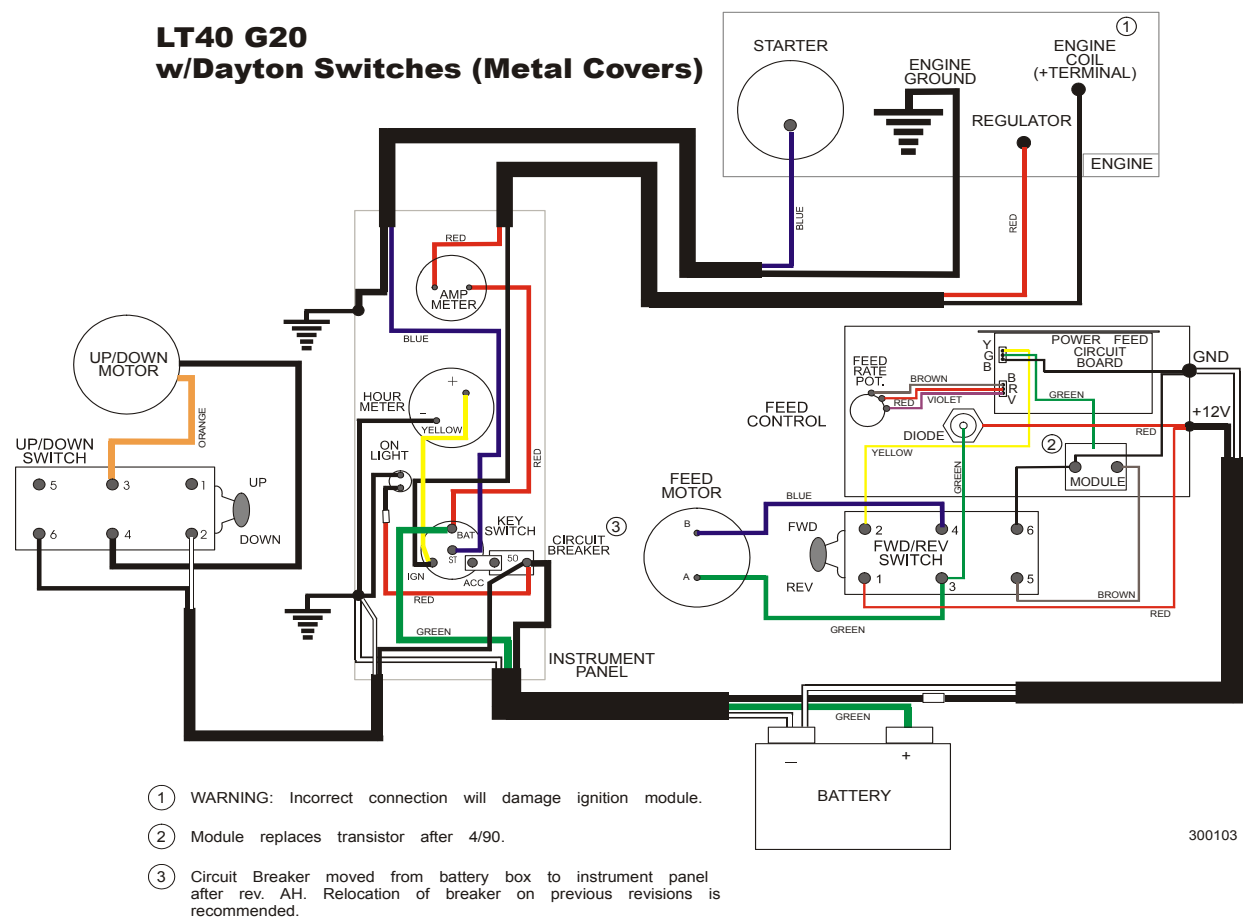

FIG. 5-2

A

air cooling system 3-4

air filter 3-2

alternator belt 3-7

B

battery handling 1-2

battery maintenance 3-6

belt
alternator tension 3-7

E

electrical components (LT30/LT40) 5-2

electrical symbol diagram (LT30/LT40) 5-1

F

fuel filter 3-5

M

maintenance 3-1

miscellaneous maintenance 3-9

O

oil 3-3

oil filter 3-3

P

parts list
how to use 4-1

R

refueling 1-1

replacement parts 4-1

S

safety information 1-1

schematics 5-1

starting 2-1
