

# **G18 Engine**

## **Safety, Operation, Maintenance & Parts Manual**

---

**LT30**  
**LT40**

**rev. J2.00 - J7.04**  
**rev. J3.00 - K3.03**

---



**Safety is our #1 concern!** Read and understand all safety information and instructions before operating, setting up or maintaining this machine.

*January 2004*

*Form #1048*

© **2017**

Printed in the United States of America. All rights reserved. No part of this manual may be reproduced in any form by any photographic, electronic, mechanical or other means or used in any information storage and retrieval system without written permission from

***Wood-Mizer***

8180 West 10th Street  
Indianapolis, Indiana 46214

<b>Table of Contents</b>	<b>Section-Page</b>
<b>ABOUT THIS MANUAL</b>	<b>IV</b>
<b>SECTION 1      OPERATION</b>	<b>1-1</b>
1.1      Starting The Engine.....	1-1
<b>SECTION 2      MAINTENANCE</b>	<b>2-1</b>
2.1      Safety.....	2-1
2.2      Cooling System.....	2-2
2.3      Air Filter & Pre-Cleaner.....	2-3
2.4      Fuel Filter.....	2-4
2.5      Battery.....	2-5
2.6      Alternator Belt.....	2-6
2.7      RPM Adjustments.....	2-7
2.8      Miscellaneous Maintenance.....	2-8
<b>SECTION 3      REPLACEMENT PARTS</b>	<b>3-1</b>
3.1      Fuel Tank.....	3-1
3.2      Engine Mount Assembly.....	3-2
3.3      Engine Assembly.....	3-3
3.4      Alternator Assembly.....	3-5
3.5      Engine Pulley Guards.....	3-7
<b>INDEX</b>	<b>I</b>

## ABOUT THIS MANUAL

This manual is provided as a supplement to the equipment manufacturer's manuals. This manual provides information specific to the use of this equipment on the Wood-Mizer<sup>®</sup> sawmill. Refer to the sawmill operator's manual and manufacturer's manual before attempting to operate this equipment.



**IMPORTANT!** Read the sawmill operator's manual and engine manufacturer's manual for instructions and safety precautions before operating this equipment.

The information and instructions given in this manual do not amend or extend the limited warranties for the equipment given at the time of purchase.

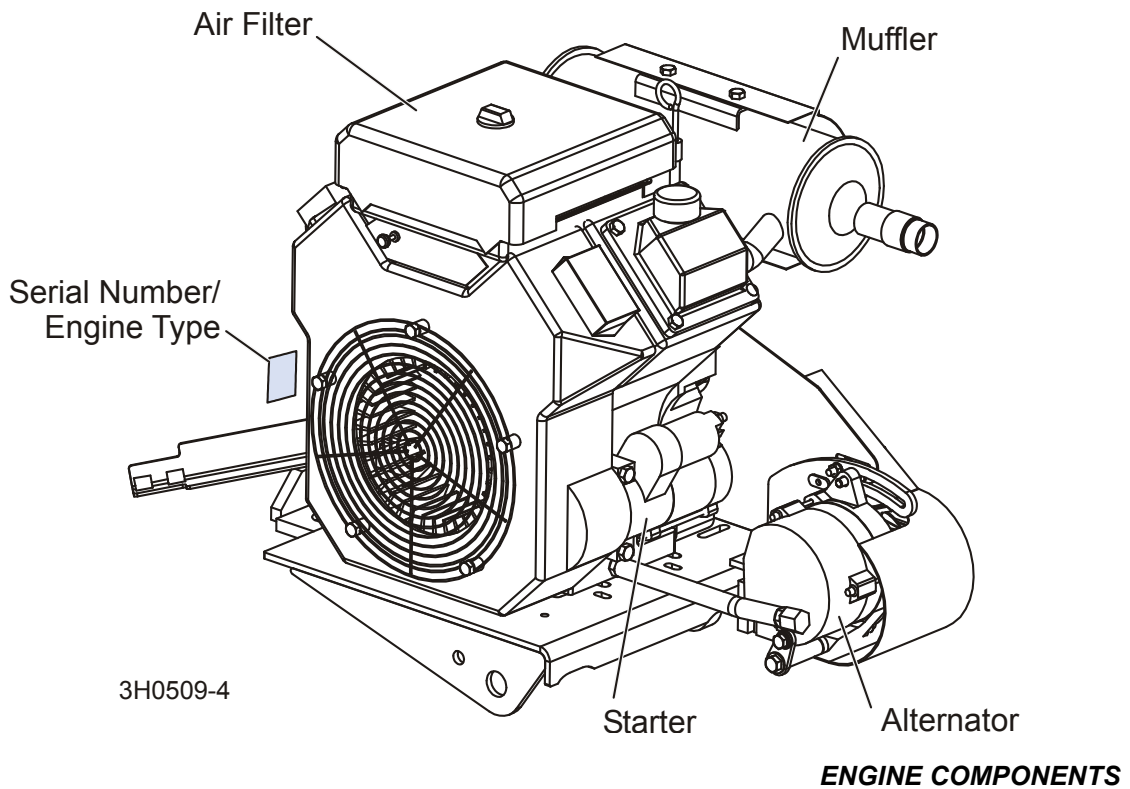





## SECTION 1 OPERATION

### 1.1 Starting The Engine

#### Engine Control Lights

See Figure 1-1. The following indicator lights are located on the sawmill control panel.

-  *Alternator Charge Indicator:* Lights up if the alternator is not charging the battery.  

-  *Key Switch Indicator:* Lights up when the key is in either the on or accessory (#1 or #3) position.  

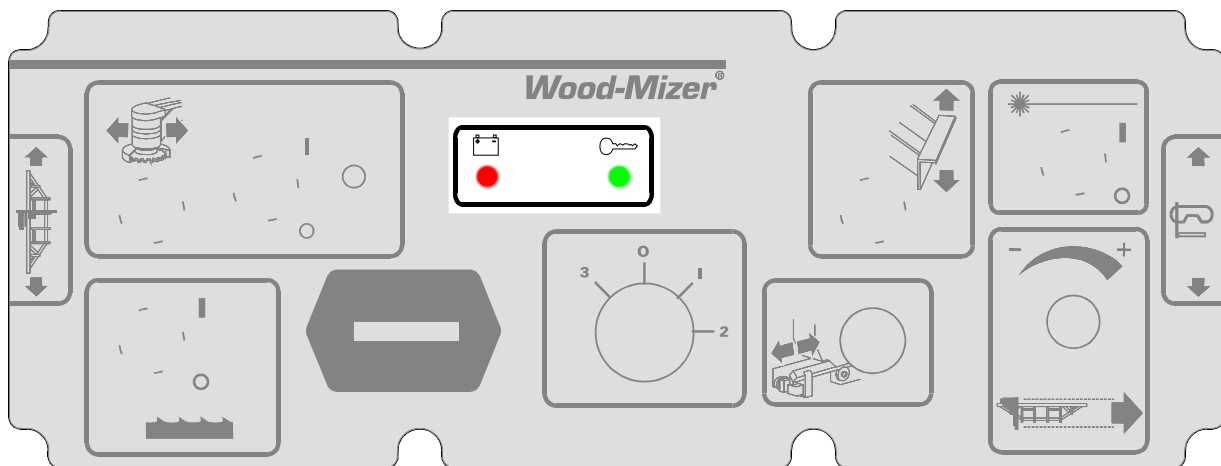

FIG. 1-1

#### Engine Start



**DANGER!** Always be sure the blade is disengaged and all persons are out of the path of the blade before starting the engine. Failure to do so will result in serious injury.

**DANGER!** Operate your engine/machine only in well ventilated areas. The exhaust gases of your engine can cause nausea, delirium and potentially death unless adequate ventilation is present.

**DANGER!** Never operate an engine with a fuel or oil leak. The leaking fuel or oil could potentially come in contact with hot surfaces and ignite into flames.



**WARNING!** Be sure the power feed switch is in the neutral position before turning the key switch to the on (#1) or accessory (#3) position. This prevents accidental carriage movement, which may cause serious injury or death.

**WARNING!** Do not operate engine without proper and operational spark arrester/muffler. Sparks emitted from the engine exhaust could ignite surrounding materials, causing serious injury or death.

Turn the key switch to the start (#2) position and release.

If the engine needs choking to start, pull the choke cable out until the engine starts. Push the choke wire in after the engine starts.

For more information, see the engine manufacturer's operation manual.

If the fuel tank was recently filled or replaced, squeeze the primer bulb once or twice before trying to start the engine. **NOTE:** If pumping problems are experienced, make sure the out-flow end of the hose line is connected to the fuel filter. If pumping problems are still experienced, hold the primer bulb in a vertical position while squeezing. This allows the fuel check valve to operate properly.

**NOTE:** When the clutch handle is engaged, an accelerator pump is activated which supplies fuel to the engine carburetor. To avoid flooding the carburetor and possibly fouling the spark plugs, do not engage the clutch lever repeatedly without the engine running.

### **Engine Shutoff**

Turn the key switch to the off (#0) position.

## SECTION 2 MAINTENANCE

Refer to the manufacturer's manual for maintenance intervals and procedures unless otherwise instructed in this manual. Follow the manufacturer's recommendations for dusty conditions.



**IMPORTANT!** This manual only provides information about additional procedures or procedures to be performed at different time intervals than found in the manufacturer's manuals. Refer to the manufacturer's manual for complete maintenance instructions.

### 2.1 Safety

Use caution when performing maintenance or service to the engine.



**DANGER!** Always be aware of and take proper protective measures against rotating shafts, pulleys, fans, etc. Always stay a safe distance from rotating members and make sure that loose clothing or long hair does not engage rotating members resulting in possible injury.

**DANGER!** Engine components can become very hot during operation. Avoid contact with any part of a hot engine. The exhaust components of your engine are especially hot during and following operation. Contact with hot engine components can cause serious burns. Therefore, never touch or perform service functions on a hot engine. Allow the engine to cool sufficiently before beginning any service function.



**WARNING!** Remove the blade before performing any engine service. Failure to do so may result in serious injury.

**WARNING!** Always wear proper and necessary safety equipment when performing service functions. Proper safety equipment includes eye protection, breathing protection, hand protection and foot protection.



**This symbol** identifies the interval (hours of operation) at which each maintenance procedure should be performed. "AR" signifies maintenance procedures which should be performed as required.

## 2.2 Cooling System

50

Wash the engine or brush off sawdust and debris every 50 hours of operation. Clean the grass screen, cooling fins, and external surfaces. Remove any dust, dirt or oil. See engine manual for further instructions.



## 2.3 Air Filter & Pre-Cleaner



**WARNING!** Always wear proper and necessary safety equipment when performing service functions. Proper safety equipment includes eye protection, breathing protection, hand protection and foot protection.



Service the pre-cleaner every four hours of operation. Service by gently shaking excess sawdust and debris from the foam piece.



Clean the air filter (air cleaner element) and pre-cleaner (element wrapper) every eight hours of operation. See the engine manual for further instructions.



Replace the air filter (cleaner) every 200 hours of operation.



Replace the pre-cleaner (element wrapper) every 2000 hours of operation.

## 2.4 Fuel Filter



Replace the fuel filter every 100 hours of operation or as required for engine performance.

## 2.5 Battery



Check the battery electrolyte level every 50 hours of operation. See manufacturer's manual for instructions.



**DANGER!** Batteries expel explosive gases. Keep sparks, flames, burning cigarettes, or other ignition sources away at all times. Always wear safety goggles and a face shield when working near batteries. Failure to do so will cause serious injury.<sup>1</sup>



**WARNING!** Battery posts, terminals and related accessories contain lead and lead compounds, chemicals known to the State of California to cause cancer and reproductive harm. Wash hands after handling.

---

1. Battery Council International, copyright 1987

## 2.6 Alternator Belt



Adjust the alternator belt as needed. Check the alternator belt for tension and wear when battery is not charging properly or when the alternator belt is squealing. To tighten the belt, loosen the adjustment bolt and lock washer. Pivot the alternator away from the motor until the belt has 3/16" (5 mm) deflection with a 5 lb. deflection force. Retighten the adjustment bolt.

See Figure 2-1.

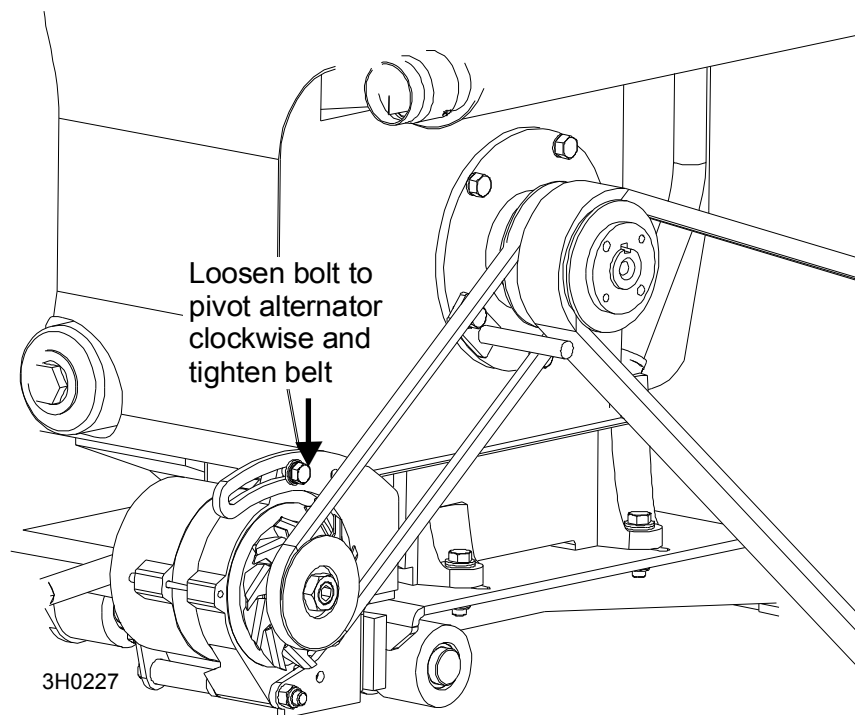

**FIG. 2-1**

## 2.7 RPM Adjustments



**WARNING!** Remove the blade before performing any engine service. Failure to do so may result in serious injury.



Check the RPM with a tachometer after the first 20 hours of operation and every 200 hours thereafter.

See Table 2-1.

Engine	High End RPM	Low End RPM
G18	3750	1800

TABLE 2-1

Before checking the RPM, make sure belt and brake strap tensions are correct (See Sawmill Maintenance). Also check oil, fuel, and coolant levels.

Make sure the throttle cable does not affect the engine RPM when the clutch handle is disengaged. Make sure the cable is not bent or kinked. Check that the cable spring, cable guide, cable, and throttle brackets are aligned. **NOTE:** It is important that the above components are aligned. Proper alignment allows any slack in the cable (when engine is idling) to slide down into the cable spring. This maintains free operation of the cable and prevents the cable from kinking. Make sure the shoulder bolt does not rub against the crankcase vent tube.

1. Start the engine to measure the low-end RPM.
2. Refer to the engine manual to adjust the low-end RPM.
3. Engage the clutch handle to throttle the engine and measure the high-end RPM. The high-end RPM is factory-set at 3750. Readjust the throttle cable if necessary to increase or reduce the high-end engine speed.

The throttle cable should be tensioned just enough so that the engine revs as soon as the clutch/brake handle is engaged. **NOTE:** A properly adjusted throttle will extend the cable spring 1/4" to 3/8" (6.4 - 9.5 mm) when running and have a slight amount of slack in the cable when idling.

## 2.8 Miscellaneous Maintenance

50

Clean and inspect the spark arresters every 50 hours of operation. Replace if damaged.

100

Inspect the spark plugs every 100 hours of operation. Remove any deposits and adjust gap if necessary. See engine manual for further information.



**CAUTION!** Do not remove the plug wire to check for electrical spark. Damage to the ignition circuit will result.

## SECTION 3 REPLACEMENT PARTS

### 3.1 Fuel Tank

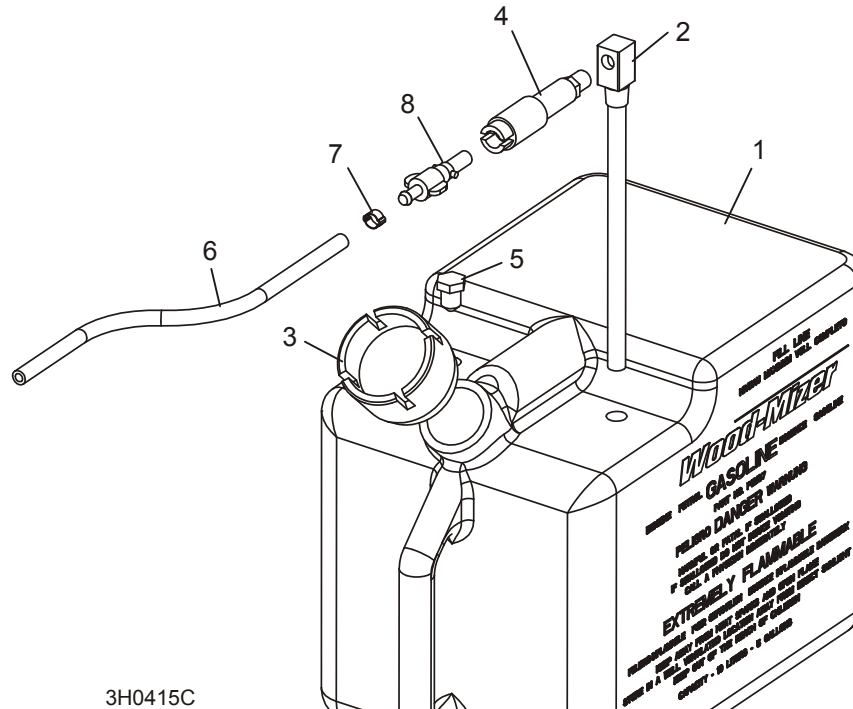

REF	DESCRIPTION (◆ Indicates Parts Available In Assemblies Only)	PART #	QTY.	
	<b>TANK ASSEMBLY, 5-GALLON RED GASOLINE</b>	A12285	1	
1	Tank, 5-Gallon Red Fuel	P12167	1	◆
2	Pickup, 9" Fuel	P12172	1	
3	Cap, 3 or 5-Gallon Fuel Tank	P09683	1	
4	Fitting, 1/4" NPT Plastic Female Disconnect	P12175	1	
5	Fitting, 3/8" NPT Hex Plug	P10367 <sup>1</sup>	1	
6	<b>HOSE, 1/4" ID FUEL</b>	P642	6.5 Ft	
7	<b>CLAMP, 7/32 - 1/2 HOSE</b>	P649	2	
8	<b>FITTING, 1/4" NPT PLASTIC MALE DISCONNECT</b>	P12176 <sup>2</sup>	1	

<sup>1</sup> Plug fitting P10367 added 11/03. Hole added to fuel tank to accommodate return line for fuel injected engines.

<sup>2</sup> Replacement requires qty. 1 hose clamp (P649).

# 3 Replacement Parts

## Engine Mount Assembly

### 3.2 Engine Mount Assembly

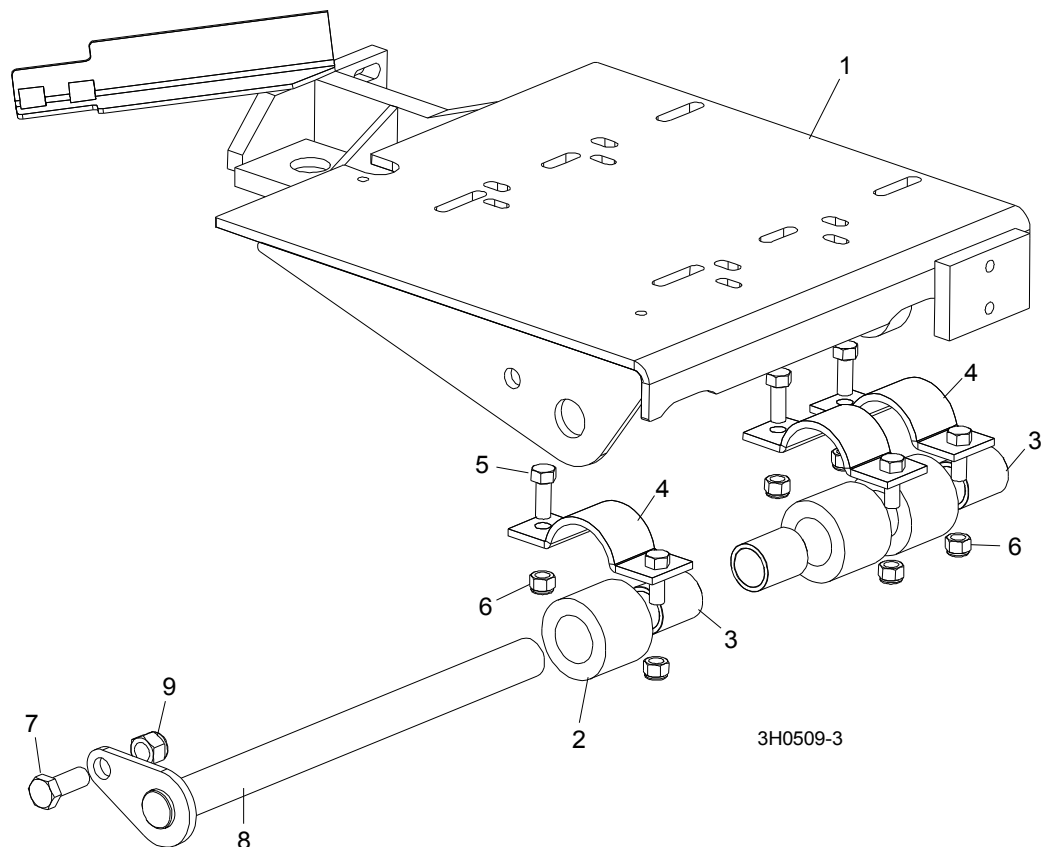

REF	DESCRIPTION (◆ Indicates Parts Available In Assemblies Only)	PART #	QTY.	
	<b>MOUNT KIT, KOHLER ENGINE</b>	016319	1	
1	Mount Weldment, Kohler Engine	014514	1	◆
	<b>BUSHING ASSEMBLY, MOTOR MOUNT</b>	016380	3	
2	Bushing, 2" OD x 2"	016378	1	◆
3	Bearing, 1" x 1 1/4" x 2"	016379	1	◆
4	<b>CLAMP WELDMENT , MOTOR MOUNT PIVOT BUSHING</b>	014540	3	
5	<b>BOLT, 3/8-16 X 1" HEX HEAD</b>	F05007-7	3	
6	<b>NUT, 3/8-16 HEX NYLON LOCK</b>	F05010-10	6	
7	<b>BOLT, 1/2-13 X 1 1/4" HEX HEAD GRADE 5</b>	F05008-37	1	
8	<b>PIN WELDMENT, ENGINE MOUNT PIVOT</b>	014154	1	
9	<b>NUT, 1/2-13 NYLON LOCK</b>	F05010-8	1	



### 3.3 Engine Assembly

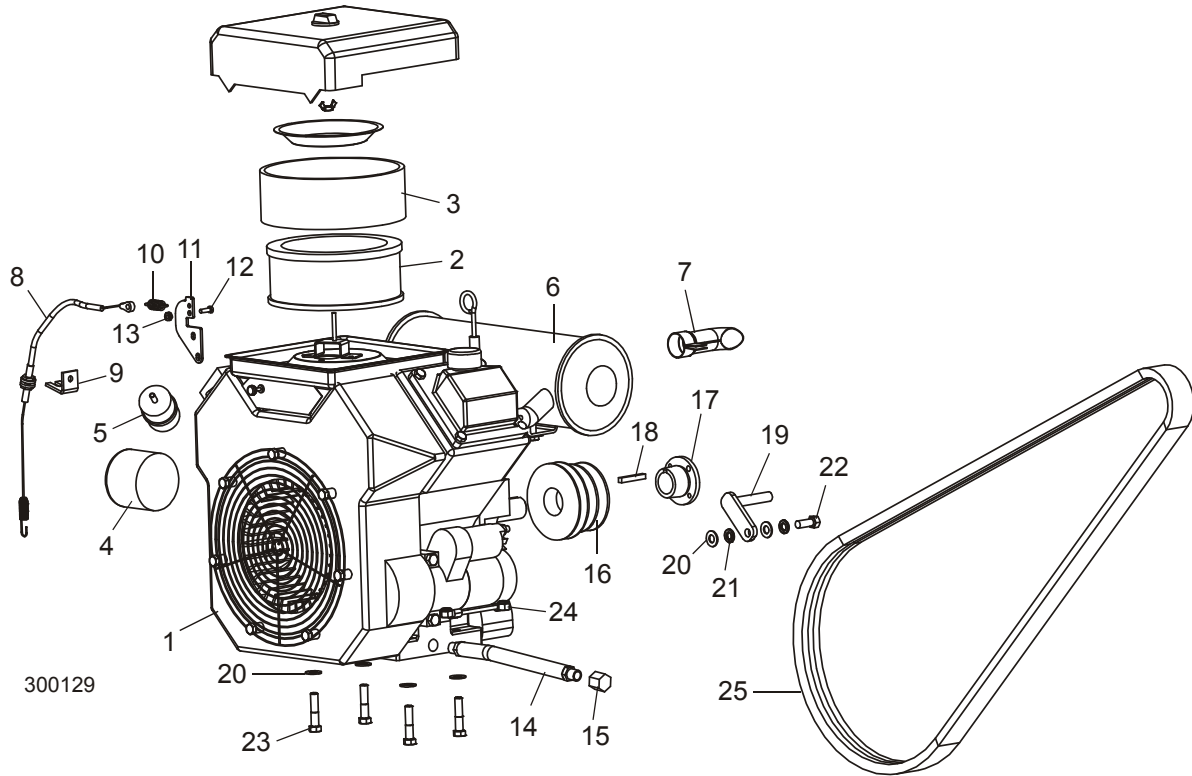

REF	DESCRIPTION (◆ Indicates Parts Available In Assemblies Only)	PART #	QTY.	
	<b>COVER, ENGINE</b>	P12393	1	
	<b>ENGINE ASSEMBLY, 18HP KOHLER</b>	017622	1	
1	Engine, 18HP Kohler #PA62590	016899	1	◆
2	Filter, Kohler Air #47-083-03	006907	1	
3	Pre Cleaner, Kohler #24-083-02	006931	1	
	Plug, RC12YC Kohler Spark #12-132-02	P12757	2	
4	Filter, Kohler Oil #52-050-02	014717	1	
5	Filter, Kohler Fuel #24-050-13	P12758 <sup>1</sup>	1	
	Pump, Kohler Fuel #24-393-16S	048391	1	
6	Muffler, Kohler #		1	
7	Arrestor, Kohler 90° Spark #24-18901-S	036684 <sup>2</sup>	1	
8	Cable, 18" Throttle	P12313	1	
	Spring, Throttle	016033	1	
9	Bracket, Throttle Cable Mount	S12312	1	
10	Spring, .5" x .08" x 1 3/8" Extension	015952	1	
11	Bracket, G25 Throttle	015964	1	
12	Bolt, #10-24 x 5/8" Hex Head	F05004-18	1	
13	Nut, #10-24 Self-Locking	F05010-14	1	

# 3

## Replacement Parts

### Engine Assembly

14	Hose, 7" Oil Drain	P10082	1	
15	Cap, Oil Drain 3/8" Pipe	P04332	1	
	Oil, 10W30 Type CD	L04869-1	.5 Gal	◆
16	Bushing, 1 1/8" Split Taper	P04306	1	
17	Pulley, 4" OD 3-Groove	S10435	1	
18	Key, 1/4" x 1/4" x 1 11/16"	S04124	1	
19	<b>BRACKET WELDMENT, DRIVE BELT SUPPORT PAINTED</b>	015963	1	
20	<b>WASHER, 3/8" SAE FLAT</b>	F05011-3	6	
21	<b>WASHER, 3/8" SPLIT LOCK</b>	F05011-4	2	
22	<b>BOLT, 3/8-16 X 1" HEX HEAD</b>	F05007-7	1	
23	<b>BOLT, 3/8-16 X 1 3/4" HEX HEAD</b>	F05007-119	4	
24	<b>NUT, 3/8-16 HEX NYLON LOCK</b>	F05010-10	4	
25	<b>BELT, 2BX71 DRIVE</b>	036163 <sup>3</sup>	1	
	<b>CARB KIT, G18 DE-ICING 24 755 64S</b>	061326	1	

<sup>1</sup> Kohler #24-050-13 9-12 micron filter replaces #240-050-10 8-10 micron filter originally supplied.

<sup>2</sup> Replaces 016142 straight spark arrestor supplied with engine prior to 11/04.

<sup>3</sup> 036163 Kevlar 2BXF71 belt replaces P12949 2BX71 belt supplied prior to 9/03. Kevlar belt reduces stretch and provides greater range of adjustment.

### 3.4 Alternator Assembly

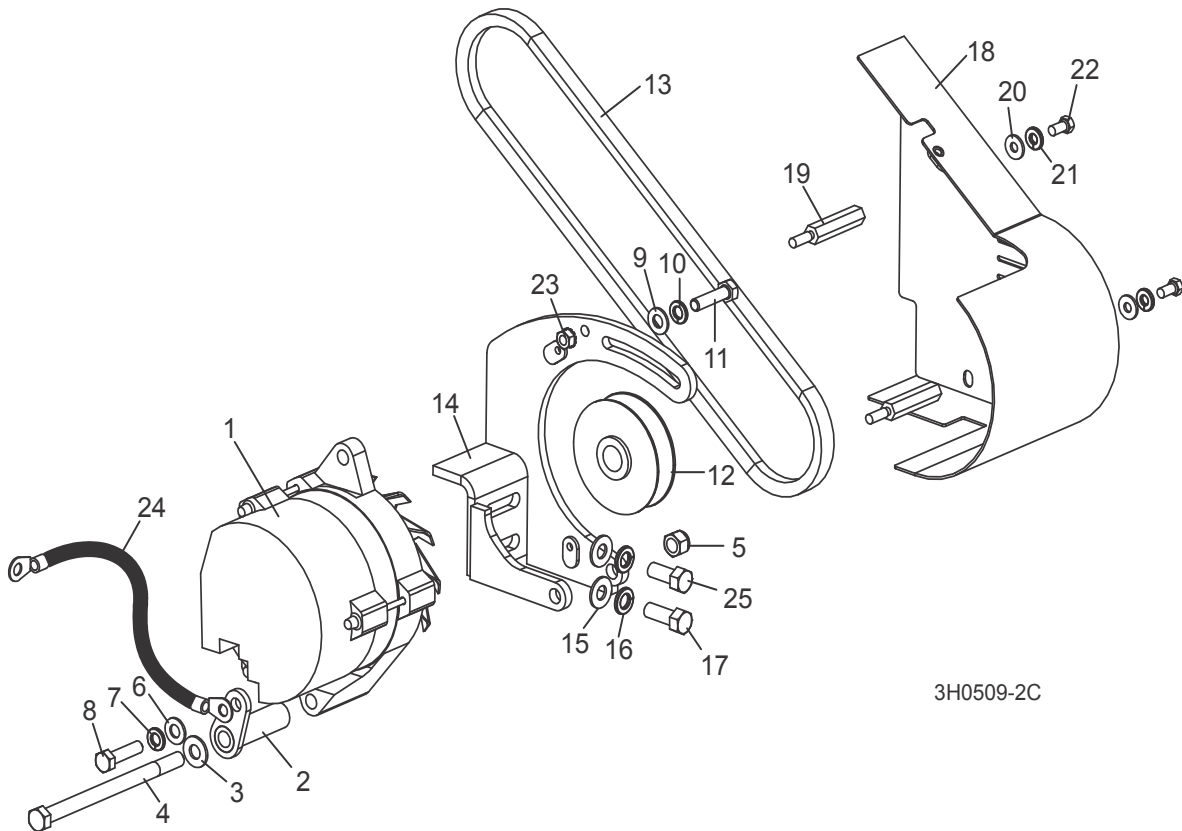

3H0509-2C

REF	DESCRIPTION (◆ Indicates Parts Available In Assemblies Only)	PART #	QTY.
1	ALTERNATOR, 12V 105A	050287	1
2	BRACE, ALTERNATOR	W12761	1
3	WASHER, 3/8" SAE FLAT	F05011-3	1
4	BOLT, 3/8-16 X 5 1/2" HEX HEAD FULL THREAD	F05007-34	1
5	NUT, 3/8-16 HEX NYLON LOCK	F05010-10	1
6	WASHER, 5/16" SAE FLAT	F05011-17	1
7	WASHER, 5/16" SPLIT LOCK	F05011-13	1
8	BOLT, M8 X 1.25" X 1" HEX HEAD FULL THREAD	F05004-40	1
9	WASHER, 5/16" SAE FLAT	F05011-17	1
10	WASHER, 5/16" SPLIT LOCK	F05011-13	1
11	BOLT, M8 X 1.25" X 1" HEX HEAD FULL THREAD	F05004-40	1
12	PULLEY, ALTERNATOR	P03806	1
13	BELT, A33 ALTERNATOR	P11542	1
	WIRE ASSEMBLY, G25 ALTERNATOR/STARTER	024308	1
	WIRE ASSEMBLY, 61/105 AMP ALTERNATOR PLUG	015969	1
14	BRACKET, ALTERNATOR MOUNT	014509	1
15	WASHER, 3/8" SAE FLAT	F05011-3	2
16	WASHER, 3/8" SPLIT LOCK	F05011-4	2

**3****Replacement Parts***Alternator Assembly*

---

17	<b>BOLT, 3/8-16 X 1" HEX HEAD</b>	F05007-7	2	
18	<b>GUARD, ALTERNATOR BELT</b>	014499	1	
19	<b>STANDOFF, 1/4-20 X 1 7/8"</b>	015957	2	
20	<b>WASHER, 1/4" SAE FLAT</b>	F05011-11	2	
21	<b>WASHER, 1/4" SPLIT LOCK</b>	F05011-14	2	
22	<b>BOLT, 1/4-20 X 1/2" HEX HEAD</b>	F05005-15	2	
23	<b>NUT, 1/4-20 SELF-LOCKING HEX</b>	F05010-9	1	
24	<b>WIRE ASSEMBLY, GROUND JUMPER</b>	017770 <sup>1</sup>	1	

<sup>1</sup> Jumper wire added to improve ground contact (LT30 Rev. J3.00, LT40 Rev. J4.00).

### 3.5 Engine Pulley Guards

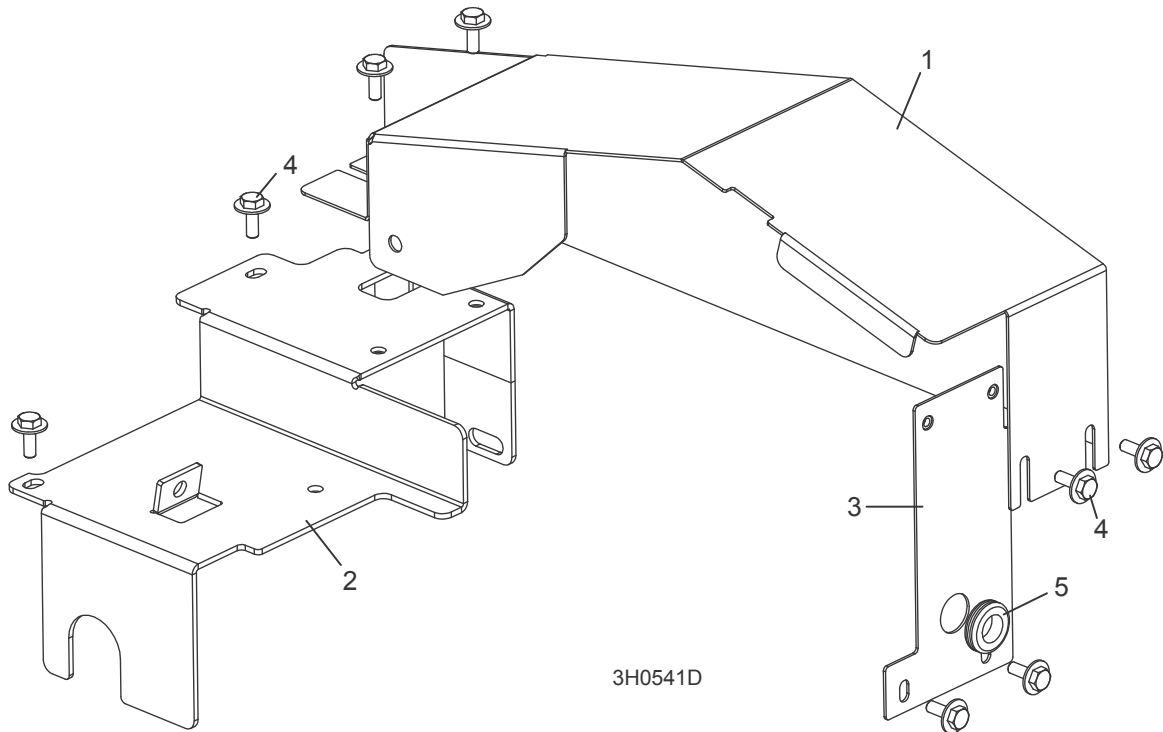

REF	DESCRIPTION (◆ Indicates Parts Available In Assemblies Only)	PART #	QTY.
1	GUARD WELDMENT, KOHLER ENGINE PULLEY	015960	1
2	GUARD, KOHLER SIDE ENGINE PULLEY	015962	1
3	GUARD, KOHLER BOTTOM ENGINE PULLEY	015961	1
4	BOLT, 1/4-20 X 3/4" HEX HEAD WITH CONICAL WASHER	F05005-134	8
5	GROMMET, 5/8" ID RUBBER	P11764	1

# INDEX

---

## M

maintenance 2-1  
  air cooling system 2-2  
  alternator belt 2-6  
  battery 2-5  
  fuel filter 2-4  
  miscellaneous 2-8  
  RPM adjustments 2-7

---

## P

parts list  
  engine assembly 3-3  
  engine mount assembly 3-2  
  fuel tank 3-1  
  pulley guards 3-7

---

## S

starting 1-1