

# Scierie Wood-Mizer®

## Manuel de pièces

---

LT40HD Super

rev. K4.02

---



**La sûreté est notre souci principal!** Lisez et comprenez toutes les informations et instructions de sûreté avant d'actionner, installer ou mettre en opération cette machine.

#536-5

**California**  
Proposition 65 Warning



**WARNING:** Breathing gas/diesel engine exhaust exposes you to chemicals known to the State of California to cause cancer and birth defects or other reproductive harm.

- Always start and operate the engine in a well-ventilated area.
- If in an enclosed area, vent the exhaust to the outside.
- Do not modify or tamper with the exhaust system.
- Do not idle the engine except as necessary.

For more information go to **[www.P65warnings.ca.gov](http://www.P65warnings.ca.gov)**.



**WARNING:** Drilling, sawing, sanding or machining wood products can expose you to wood dust, a substance known to the State of California to cause cancer. Avoid inhaling wood dust or use a dust mask or other safeguards for personal protection.

For more information go to **[www.P65Warnings.ca.gov/wood](http://www.P65Warnings.ca.gov/wood)**.

**Active Patents assigned to Wood-Mizer, LLC**

Wood-Mizer, LLC has received patents that protect our inventions which are a result of a dedication to research, innovation, development, and design. Learn more at: [woodmizer.com/patents](http://woodmizer.com/patents)

**©2022 Wood-Mizer LLC**

Printed in the United States of America, all rights reserved. No part of this manual may be reproduced in any form by any photographic, electronic, mechanical or other means or used in any information storage and retrieval system without written permission from

**Wood-Mizer, LLC**  
**8180 West 10th Street**  
**Indianapolis, Indiana 46214**

<b>PARTIE 1</b>	<b>SYSTÈMES DE GUIDAGE DE LAME</b>	<b>1-1</b>
1.1	Guidage De Lame, Côté Poulie Folle.....	1-1
1.2	Guidage De Lame, Côté Entraînement.....	1-3
1.3	Système D'entraînement De Bras De Guidage.....	1-7
1.4	Bras de Guidage de Lame.....	1-8
<b>PARTIE 2</b>	<b>POULIES ET TENDEUR</b>	<b>2-1</b>
2.1	Système D'entraînement De Lame .....	2-1
2.2	Poulie Folle.....	2-2
2.3	Tendeur Hydraulique De Lame .....	2-3
<b>PARTIE 3</b>	<b>TÊTE DE SCIE</b>	<b>3-1</b>
3.1	Vis Anti-Vibration.....	3-1
3.2	Valve Du Contrôle De Lubrification.....	3-2
3.3	Clutch Pivot.....	3-3
3.4	Fixation d'embrayage .....	3-4
3.5	Système De Freinage.....	3-5
3.6	Éjecteur De Planches.....	3-6
3.7	Système De Lubrification (Gas).....	3-8
3.8	Système De Lubrification (Diesel & Electric) .....	3-9
3.9	Étiquettes D'avertissement .....	3-10
3.10	Couvercles De Carters De Lame .....	3-11
3.11	Couvercles De Carters De Courroies .....	3-12
3.12	Chute À Bran De Scie .....	3-13
3.13	Boîte De Filage De L'écorceuse Et Obturateurs.....	3-14
<b>PARTIE 4</b>	<b>SYSTÈME DE COMMANDE ET BATTERIE</b>	<b>4-1</b>
4.1	Système De Commande .....	4-1
4.2	Systeme De Commande (Tier4 Seulement) .....	4-3
4.3	Commutateurs.....	4-5
4.4	Disjoncteurs.....	4-6
4.5	Panneau De Commande .....	4-7
4.6	Panneau De Commande (Tier4 Seulement) .....	4-9
4.7	Boîte De Batterie .....	4-10
4.8	Boîte De Fusibles .....	4-11
<b>PARTIE 5</b>	<b>SYSTÈME DE MONTÉE</b>	<b>5-1</b>
5.1	Fixation De La Tête De Sciage .....	5-1
5.2	Indicateur De Hauteur Et Règles De Débitage.....	5-2
5.3	Chaînes Et Pignons De Montée.....	5-3
5.4	Moteur De Montée .....	5-4
5.5	Système D'entraînement De Montée .....	5-5

<b>PARTIE 6</b>	<b>SYSTÈME D'ENTRAÎNEMENT ET PALIERS</b>	<b>6-1</b>
6.1	Paliers de Rail Supérieur et Grattoirs .....	6-1
6.2	Système D'entraînement .....	6-3
6.3	Chaîne D'entraînement Et Butoir .....	6-5
6.4	Paliers De Rail Inférieur .....	6-6
<b>PARTIE 7</b>	<b>BÂTI DE LA SCIE</b>	<b>7-1</b>
7.1	Rails Avant Et Arrière Du Banc De Grume .....	7-1
7.2	Rail Centre-avant Du Banc De Grume .....	7-2
7.3	Rail Centre-arrière Du Banc De Grume .....	7-3
7.4	Appuis Fixes .....	7-4
7.5	Table D'éjecteur De Planches .....	7-5
7.6	Support De Grume Mobile .....	7-6
7.7	Chaîne De Sécurité .....	7-7
7.8	Attache De La Tête De Scie .....	7-8
7.9	Étiquettes D'avertissement .....	7-9
7.10	Table De Planches (Optionnel) .....	7-10
<b>PARTIE 8</b>	<b>SYSTÈME HYDRAULIQUE</b>	<b>8-1</b>
8.1	Boîte De Commande Des Hydrauliques.....	8-1
8.2	Plaque De Contact Hydraulique Et Bornes .....	8-3
8.3	Chargeuse Hydraulique .....	8-4
8.4	Tourne-bille Hydraulique .....	8-6
8.5	Cales Hydrauliques (Avant/Arrière).....	8-7
8.6	Cales Hydrauliques (Centre) .....	8-8
8.7	Serre Hydraulique.....	8-9
8.8	Niveleur De Grume Hydraulique .....	8-10

## PARTIE 1 SYSTÈMES DE GUIDAGE DE LAME

### 1.1 Guidage De Lame, Côté Poulie Folle

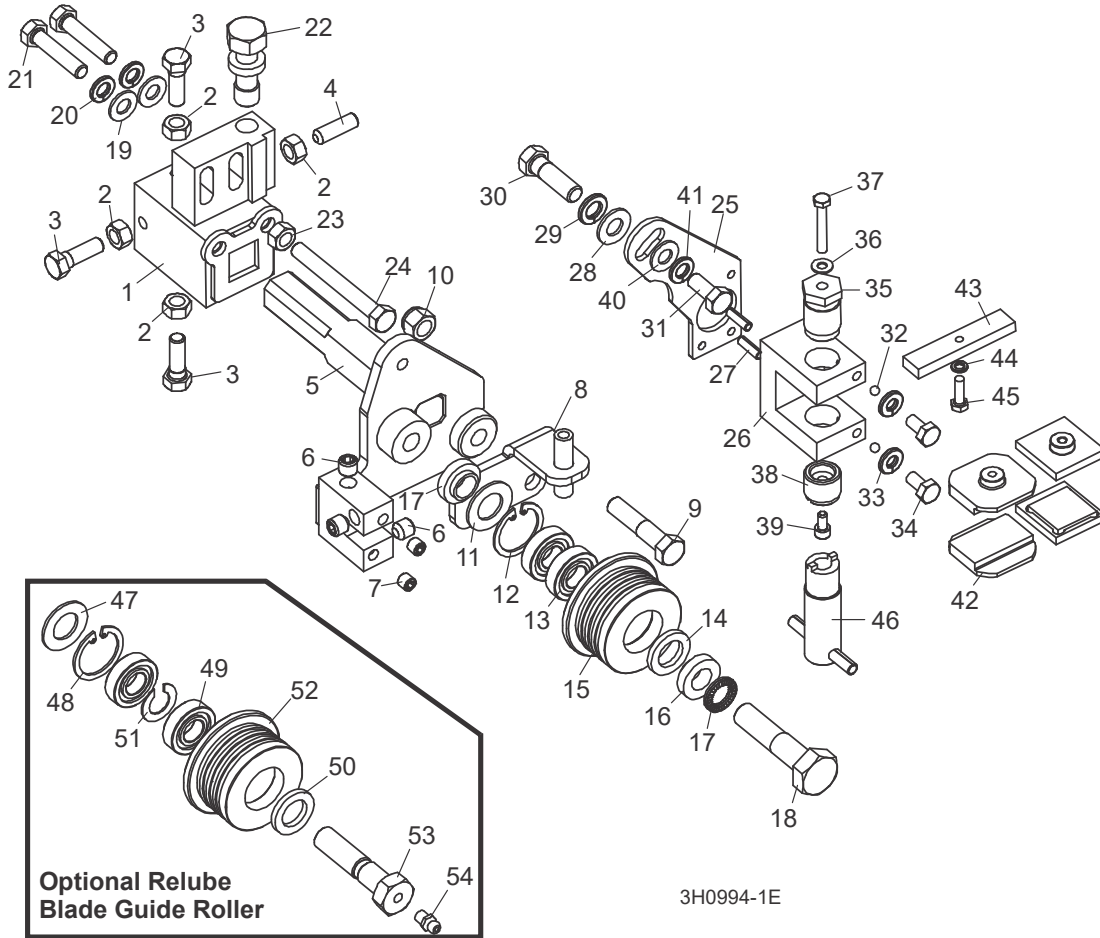

REF	PART #	QTY.
1-24	003992	1
1-4	003920	1
1	-----	1
2	F05010-17	4
3	F05006-88	3
4	F05006-122	1
5	003924	1
6	P30127	3
7	007734	2
8	006322	1
9	F05007-78	1

10	F05010-10	1
11-15	A04925	1
11-14	K07079	1
11	P04252	1
12	F04254-1	1
13	-----	2
14	P06455	1
15	S04250	1
16	S04253	2
17	F05011-125	1
18	F05008-10	1
19	F05011-17	2

20	F05011-13	2
21	F05006-76	2
22	035656	1
23	F05010-17	1
24	F05006-136	1
25-46	006325	1
25-41	003928 <sup>1</sup>	1
25	003915	1
26	003909	1
27	F05012-22	2
28	F05011-3	1
29	F05011-4	1

**1****Systèmes De Guidage De Lame**  
*Guidage De Lame, Côté Poulie Folle*

<b>30</b>	F05007-123	1
<b>31</b>	F05006-102	1
<b>32</b>	003914	2
<b>33</b>	F05011-14	2
<b>34</b>	F05005-15	2
<b>35</b>	003994	1
<b>36</b>	042867	1
<b>37</b>	F05004-240	1
<b>38</b>	044057	1
<b>39</b>	F05004-200	1
<b>40</b>	F05011-17	1
<b>41</b>	F05011-13	1
<b>42</b>	052355 <sup>2</sup>	2
	036347 <sup>3</sup>	2
<b>43</b>	035799	1
<b>44</b>	F05011-20	1
<b>45</b>	F05004-152	1
<b>46</b>	044064	1
	035248	1
	<a href="#">(Voir Partie 1.2)</a>	
<b>47-52</b>	016568	1
<b>47-51</b>	057407	1
<b>47</b>	P04252	1
<b>48</b>	F04254-1	1
<b>49</b>	015975	2
<b>50</b>	P06455	1
<b>51</b>	035411	1
<b>52</b>	035426	1
<b>53</b>	036161	1
<b>54</b>	P05060	1

<sup>1</sup> Optionelle.

<sup>2</sup> Std. 1 1/4" lame.

<sup>3</sup> Optionelle 1 1/4" lame.

## 1.2 Guidage De Lame, Côté Entraînement

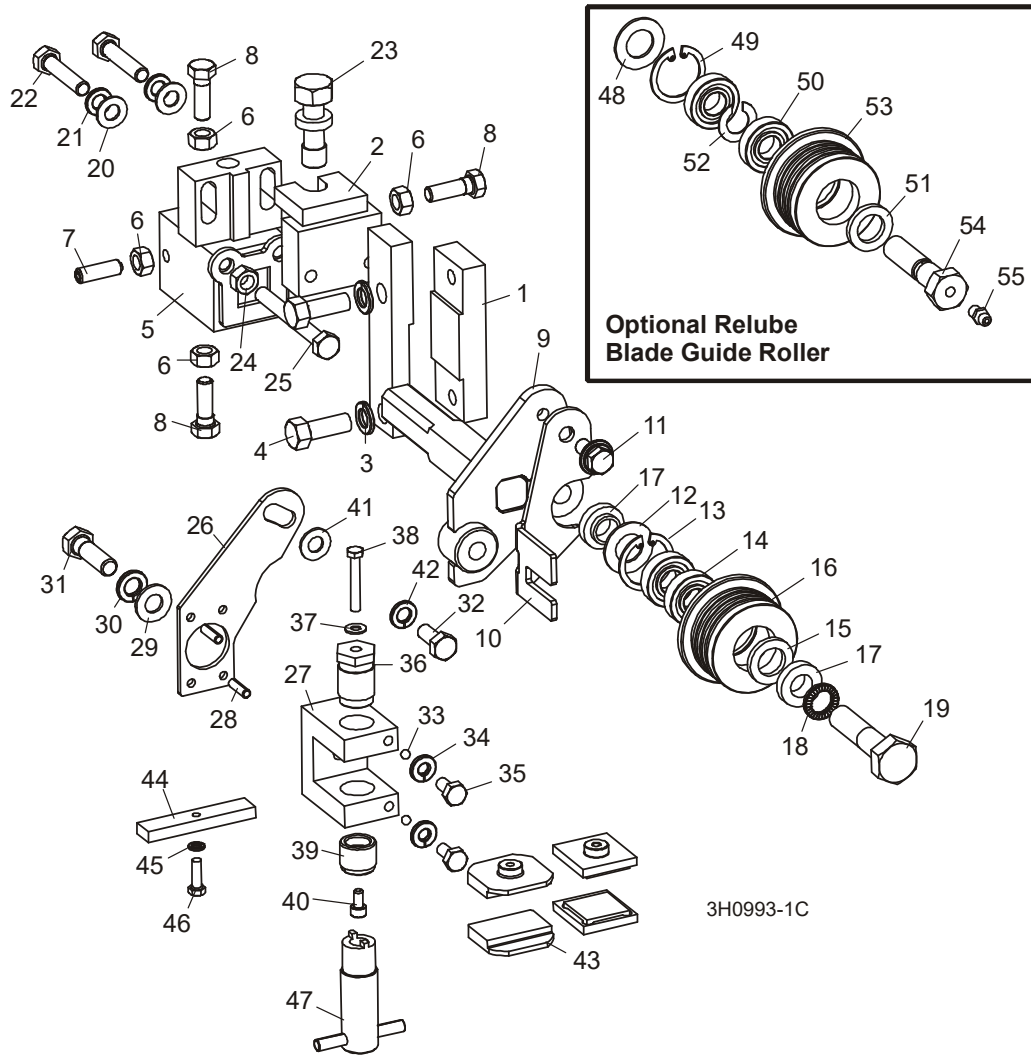

REF	PART #	QTY.
1	016548	1
2	003964	1
3	F05011-4	2
4	F05007-7	2
1-25	003905	1
5-8	003910	1
5	-----	1
6	F05010-17	4
7	F05006-122	1
8	F05006-88	3
9	003913	1

10	003916	1
11	F05006-101	1
12-16	A04925	1
12-15	K07079	1
12	P04252	1
13	F04254-1	1
14	-----	2
15	P06455	1
16	-----	1
17	S04253	2
18	F05011-125	1
19	F05008-10	1

20	F05011-17	2
21	F05011-13	2
22	F05006-76	2
23	035656	1
24	F05010-17	1
25	F05006-16	1
26-45	006325 <sup>1</sup>	1
26-40	003927	1
26	003915	1
27	003909	1
28	F05012-22	2
29	F05011-3	1

# 1

## Systèmes De Guidage De Lame

### Guidage De Lame, Côté Entraînement

30	F05011-4	1
31	F05007-123	1
32	F05006-101	1
33	003914	2
34	F05011-14	2
35	F05005-15	2
36	003994	1
37	042867	1
38	F05004-240	1
39	044057	1
40	F05004-200	1
41	052355 <sup>2</sup>	2
	036347 <sup>3</sup>	2
42	035799	1
43	F05011-20	1
44	F05004-152	1
45	044064	1
	<a href="#">(Voir Partie 1.1)</a>	
46-51	016568	1
46-50	057407	1
46	P04252	1
47	F04254-1	1
48	-----	2
49	P06455	1
50	035411	1
51	-----	1
52	036161	1
53	P05060	1

- 1 Optionelle.  
 2 Std. 1 1/4" lame.  
 3 Optionelle 1 1/4" lame.

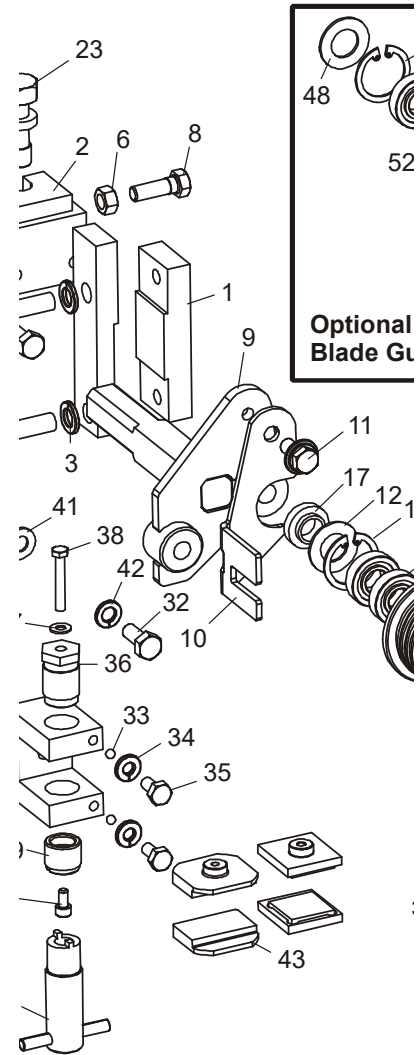

REF	DESCRIPTION (◆ Indicates Parts Available In Assemblies Only)	PART #	QTY.
1	BLOCK, BOLT ON BLADE GUIDE MOUNT	016548	1
2	BRACKET WELDMENT, INNER BLADE GUIDE MOUNT	003964	1
3	WASHER, 3/8" SPLIT LOCK	F05011-4	2
4	BOLT, 3/8-16 X 1" HEX HEAD	F05007-7	2
	GUIDE ASSEMBLY, DRIVE SIDE BLADE ROLLER	003905	1
	Block Assembly, Blade Guide Mount	003910	1
5	Block Weldment, Blade Guide Mount	003911	1
6	Nut, 5/16-18 Hex	F05010-17	4
7	Screw, 5/16-18 x 1" Socket Head Flat Point Stainless Steel Set	F05006-122	1
8	Bolt, 5/16-18 x 1" Hex Head Stainless Steel	F05006-88	3
9	Shaft Weldment, Drive Side Guide	003913	1
10	Plate, Blade Guide Deflector	003916	1
11	Bolt, 5/16-18 x 3/4" Hex Head w/Flat & Lock Washer	F05006-101	1



	Roller Assembly, Blade Guide (standard)	A04925	1	
	Bearing Kit, Blade Guide Rebuild	K07079	1	
12	Washer, 5/8" White Felt	P04252	1	
13	Ring, 1 1/8" Interior Retaining	F04254-1	1	
14	Bearing, R8-2RS Blade Guide	015975	2	◆
15	Washer, 5/8" Gray Felt	P06455	1	
	Screw, 1/4-28 x 1/4" Socket Head Cup Point Set Black Oxide	F05005-105	1	
	Instruction Sheet, Blade Guide Rebuild	057407-1507	1	
16	Roller, Flanged Blade Guide	S04250	1	◆
	Instruction Sheet, Blade Guide Roller Replacement	A04925-364	1	
17	Spacer, Blade Guide	S04253	2	
18	Washer, 1/2" Nord-Lock	F05011-125	1	
19	Bolt, 1/2-13 x 2 1/4" Hex Head Grade 5	F05008-10	1	
20	Washer, 5/16" SAE Flat	F05011-17	2	
21	Washer, 5/16" Split Lock	F05011-13	2	
22	Bolt, 5/16-18 x 1 1/2" Hex Head	F05006-76	2	
23	Bolt, Blade Guide Vertical Adjustment	035656	1	
24	Nut, 5/16-18 Hex	F05010-17	1	
25	Bolt, 5/16-18 x 2 3/4" Hex Head Full Thread	F05006-136	1	
	<b>GUIDE KIT, HIGH-PERFORMANCE BLADE GUIDE (OPTIONAL)</b>			
	Block Assembly, Drive Side Blade Guide	003927	1	
26	Plate, Block Tilt Adjustment	003915	1	
27	Block, Guide Block Mount	003909	1	
28	Pin, 3/16" x 5/8" Roll	F05012-22	2	
29	Washer, 3/8" SAE Flat	F05011-3	1	
30	Washer, 3/8" Split Lock	F05011-4	1	
31	Bolt, 3/8-16 x 1 1/4" Hex Head Grade 5	F05007-123	1	
32	Bolt, 5/16-18 x 3/4" Hex Head	F05006-102	1	
33	Ball, 3/16" Dia. Nylon	003914	2	
34	Washer, 1/4" Split Lock	F05011-14	2	
35	Bolt, 1/4-20 x 1/2" Hex Head	F05005-15	2	
36	Bolt, Blade Guide Block Mount	003994	1	
37	Washer, #10 Brass	042867	1	
38	Bolt, #10-32 x 1 1/4" Hex Head Stainless Steel	F05004-240	1	
39	Screw, Lower Block Adjustment	044057	1	
40	Screw, #10-32 x 3/8" Socket Head Stainless Steel	F05004-200	1	
41	Washer, 5/16" SAE Flat	F05011-17	1	
42	Washer, 5/16" Split Lock	F05011-13	1	
43	Block, Blade Guide Wear (Standard for 1 1/4" Blades)	052355 <sup>2</sup>	2	
	Block Assembly, 1" Sq. EZ-Glide Wear	036347 <sup>2</sup>	2	
44	Block, Blade Guide Alignment	035799	1	
45	Washer, #10 Split Lock	F05011-20	1	
46	Screw, #10-32 x 5/8" Hex Head	F05004-152	1	

## 1

## Systèmes De Guidage De Lame

### Guidage De Lame, Côté Entraînement

47	Adjustment Tool, Lower Guide Block	044064	1	
	Shim, .008" Blade Guide Block Spacer	035248	1	
	Idle Side Blade Guide Parts ( <a href="#">Voir Partie 2.1</a> )			
	<b>ROLLER ASSEMBLY, BLADE GUIDE RELUBE (OPTIONAL)</b>	016568	1	
	Bearing Kit, Relube Blade Guide Rebuild	057407	1	
48	Washer, 5/8" White Felt	P04252	1	
49	Ring, 1 1/8" Interior Retaining	F04254-1	1	
50	Bearing, R8-2RS Blade Guide	015975 <sup>3</sup>	2	◆
51	Washer, 5/8" Gray Felt	P06455	1	
52	Spacer, Blade Guide Bearing	035411	1	
	Instruction Sheet, Blade Guide Rebuild	057407-1507	1	
53	Roller, Flanged Blade Guide (Relube)	035426	1	◆
	Instruction Sheet, Blade Guide Roller Replacement	A04925-364	1	
54	<b>BOLT, BLADE GUIDE ROLLER (RELUBE ONLY)</b>	036161	1	
55	<b>FITTING, 1/4-28 GREASE (RELUBE ONLY)</b>	P05060	1	

<sup>1</sup> High-Performance Blade Guide Kit requires LMS blade lube system. Use kit 006325 to upgrade both drive and idle side blade guides to High-Performance. If sawmill not already equipped with LMS, add kit LMS-A.

<sup>2</sup> 052355 blocks for use with 1 1/4" blade provided as standard equipment. EZ-Glide blocks 036347 are available for customers who prefer this block.

<sup>3</sup> Bearing must be modified for use with relube roller assemblies. Remove one seal from each bearing, place open sides facing each other and place spacer 035411 between bearings.

### 1.3 Système D'entraînement De Bras De Guidage

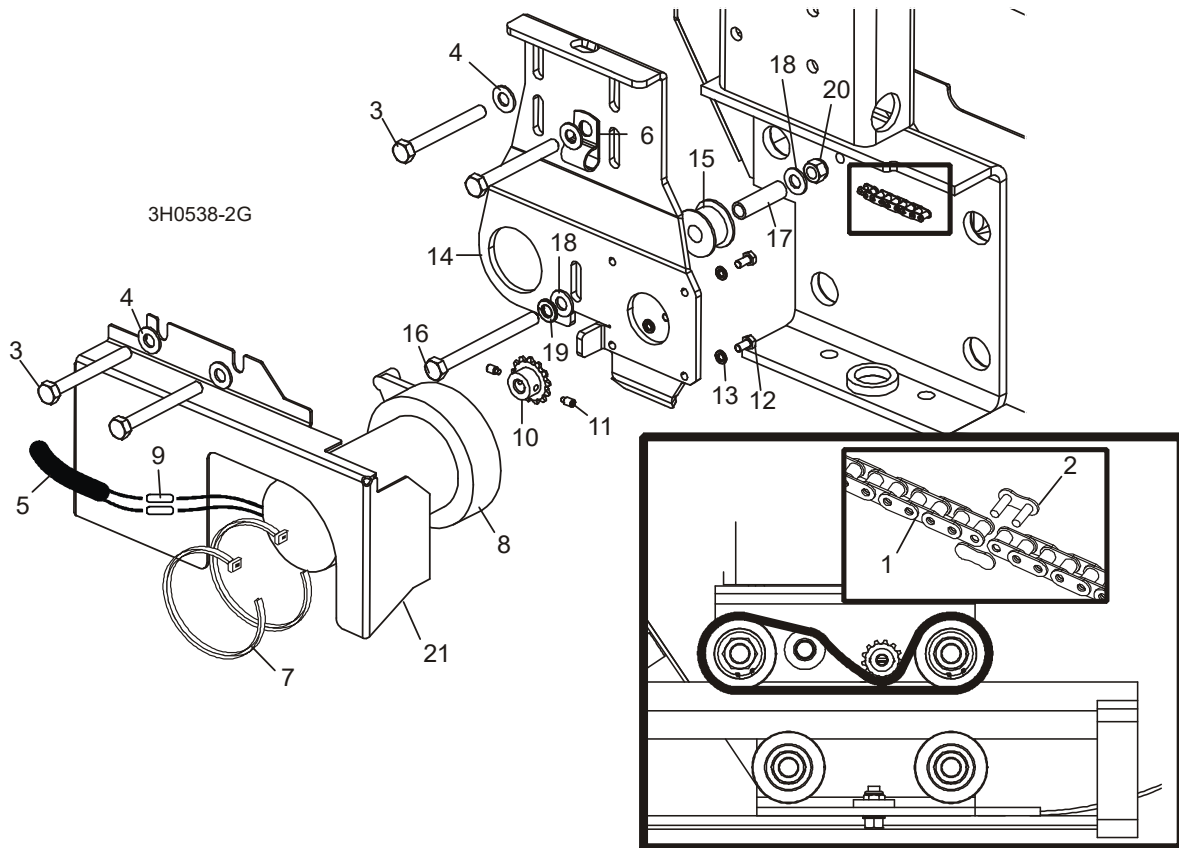

REF	PART #	QTY.
1	P09984	1
2	P09983	1
3	F05006-28	4
4	F05011-17	4
5	R01897	2.5ft
6	P07584	2
7	F05089-1	2
8-20	015989	1
8-13	079215	1
8	079214	1
	061232	1
	061234	1
	061233	1
9	F04875-1	2
10-11	P09970	1

11	F05004-274	2
12	F05004-60	4
13	F05011-20	4
14	015939	1
15	S09999	1
16	F05006-3	1
17	S09996-W	1
18	F05011-17	2
19	F05011-13	1
20	F05010-58	1
21	S11617	1

### 1.4 Bras de Guidage de Lame

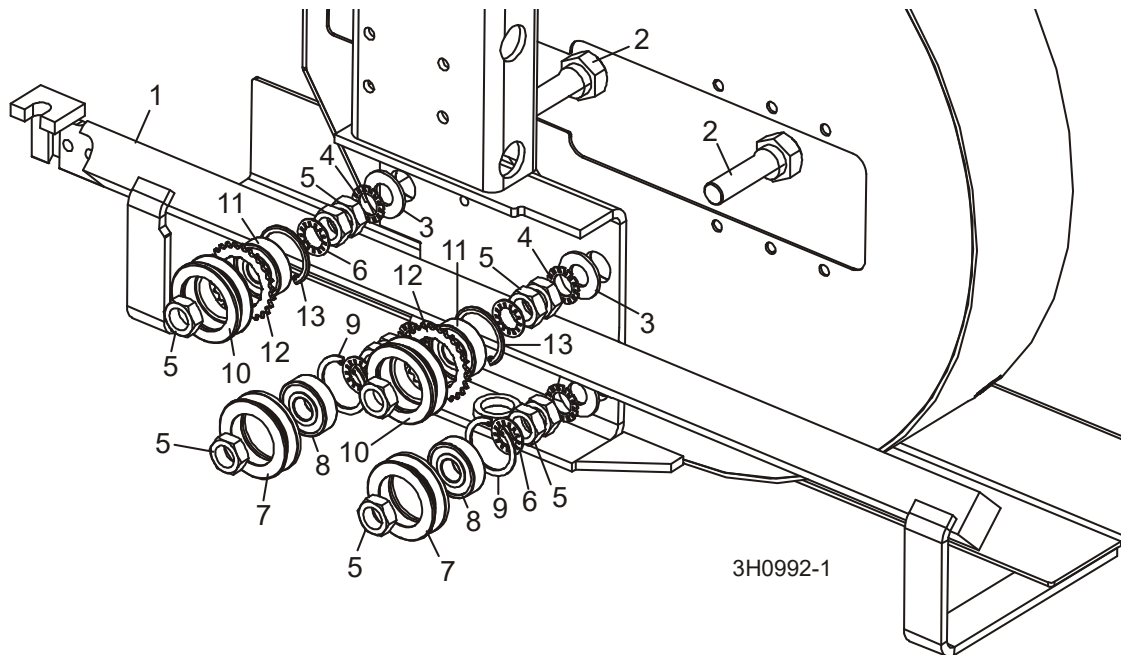

REF	PART #	QTY.
1	003972	1
1	007040 (Wide)	1
2	W09067	4
3	F05011-5	4
4	F05011-26	4
5	F05010-11	12
6	F05011-25	8
7-9	A09059	2
7	S07989	1
8	P06030-1	1
9	F04254-8	1
10-13	A09932	2
10	S09930	1
11	P06030-1	1
12	S09931	1
13	F04254-8	1

## PARTIE 2 POULIES ET TENDEUR

### 2.1 Système D'entraînement De Lame

LT30HD D35/D36  
 LT40HD D35/D36/G38

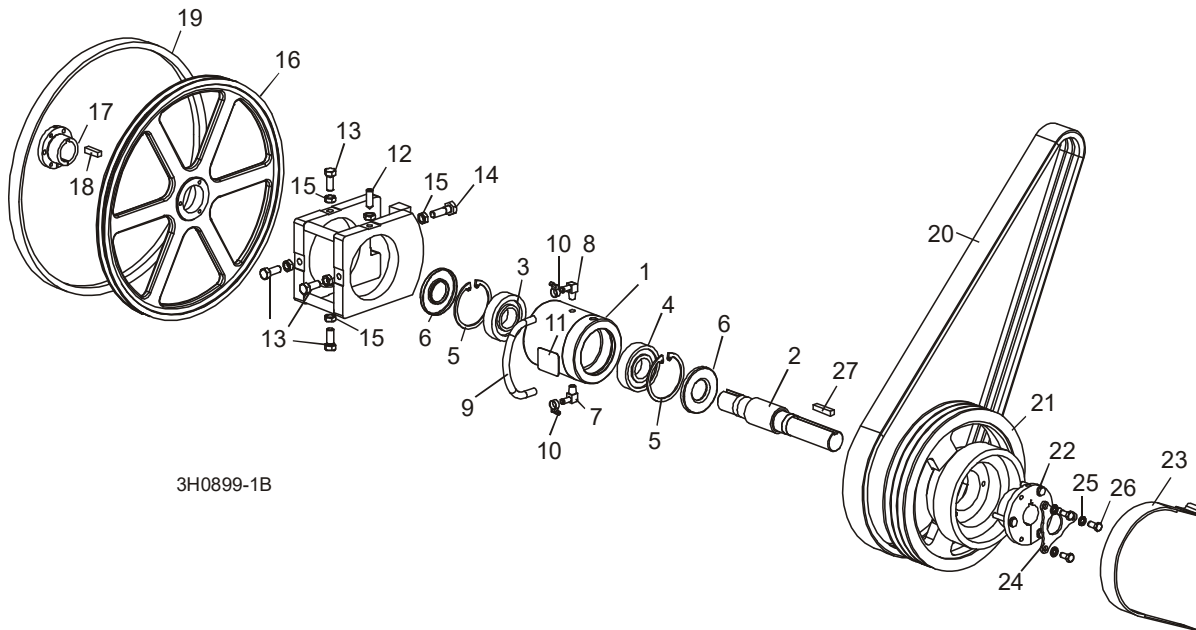

3H0899-1B

REF	PART #	QTY.
1-11	016393	1
1-6	-----	1
1	-----	1
2	-----	1
3	-----	1
4	-----	1
5	F04254-17	2
6	P10206	2
7	016330	1
8	016331	1
9	016394	1
10	P649	2
11	017470	1
12	F05004-170	1
13	F05008-108	4
14	F05008-49	1
15	F05010-16	6

16-18	014562	1
16	016284	1
17	016270	1
18	S12892	1
19	P04185	1
20	046571 <sup>1</sup>	1
	006672 <sup>2</sup>	1
21	016531	1
22	016532	1
23	014391	1
24	017953	1
25	F05011-4	3
26	F05007-27	3
27	014693	1

<sup>1</sup> D35/D36  
<sup>2</sup> G38

## 2.2 Système D'entraînement De Lame

**LT40HD G28**

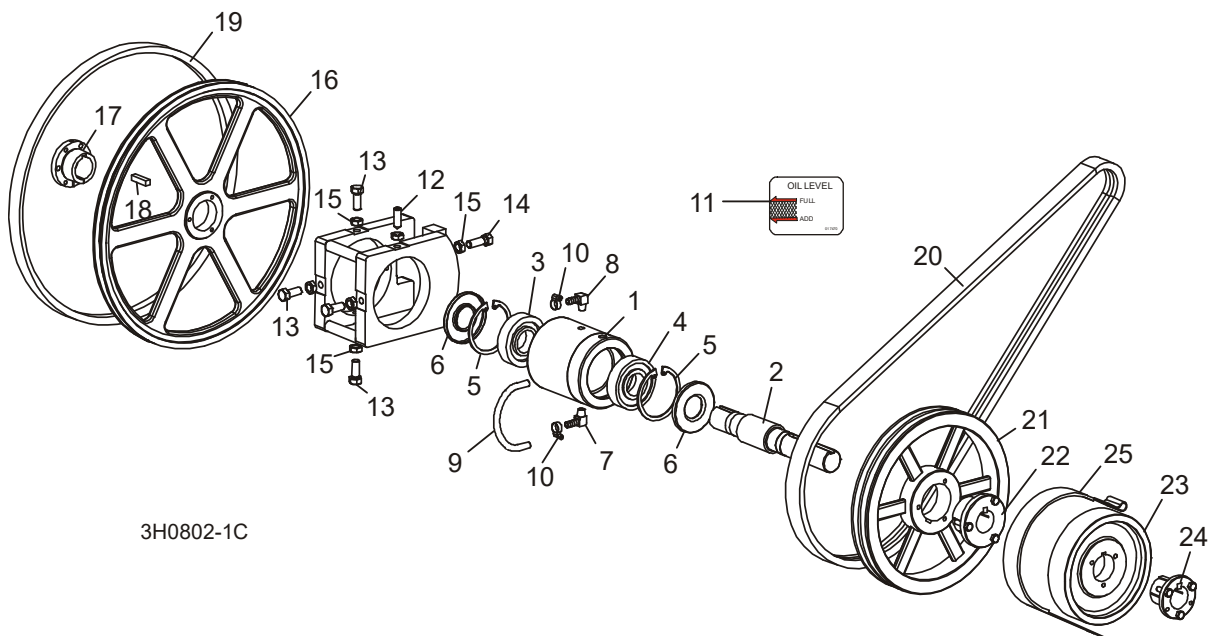

3H0802-1C

REF	PART #	QTY.
1-11	016393	1
1-6	-----	1
1	-----	1
2	-----	1
3	-----	1
4	-----	1
5	F04254-17	2
6	P10206	2
7	016330	1
8	016331	1
9	016394	1
10	P649	2
11	017470	1
12	F05004-170	1
13	F05008-108	4
14	F05008-49	1
15	F05010-16	6
16-18	014562	1
16	016284	1
17	016270	1
18	S12892	1

19	P04185	1
20	036163	1
21-22	014692	1
21	-----	1
22	014690	1
23	014000	1
24	014003	1
25	014391	1

### 2.3 Poulie Folle

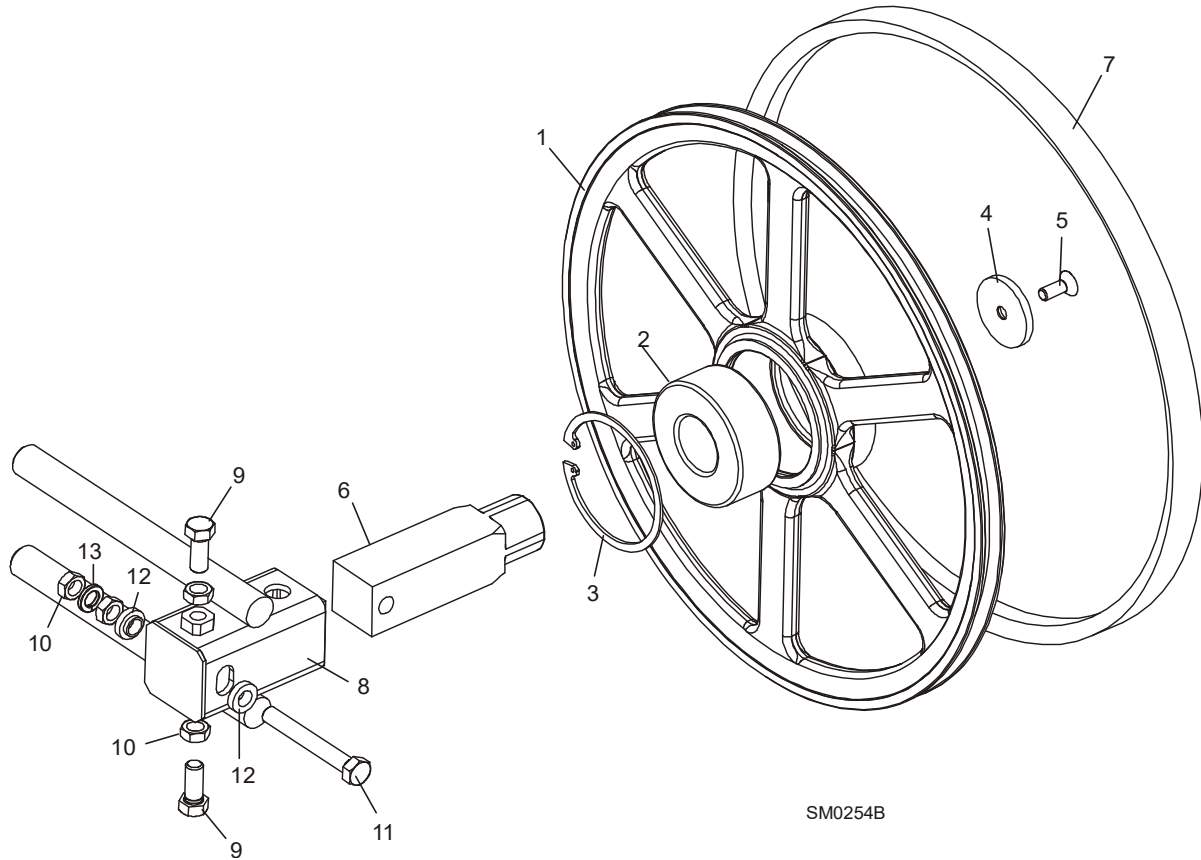

SM0254B

REF	PART #	QTY.
1-3	016120	1
1	----	1
2	016014	1
3	F04254-28	1
4-6	016441	1
4	016397	1
5	F05007-64	1
6	016398	1
7	P04185	1
8	016103	1
9	F05008-53	2
10	F05010-16	4
11	F05008-111	1
12	S04253	2
13	F05011-9	1

## 2.4 Tendeur Hydraulique De Lame

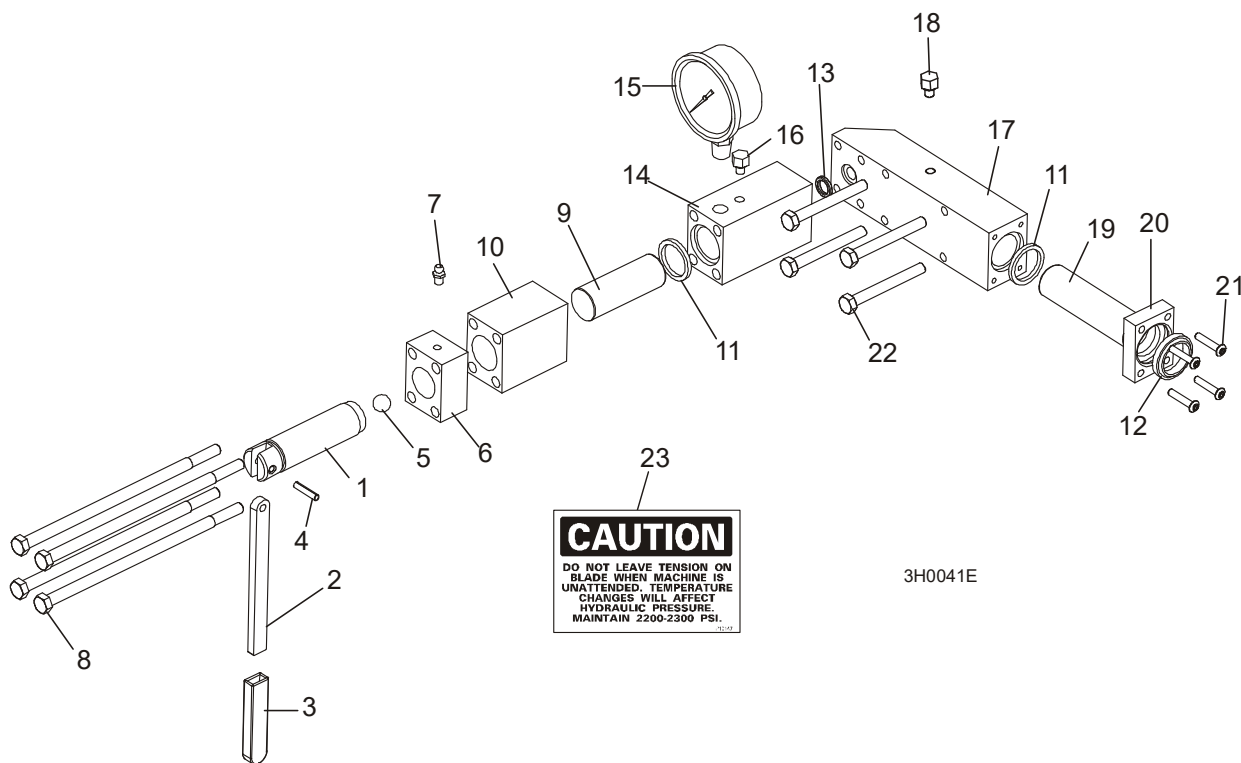

REF	PART #	QTY.
1-22	A10136	1
1-7	A12294	1
1	S10056	1
2	S08174	1
3	P08072	1
4	F05012-19	1
5	P02720	1
6	-----	1
7	P05060	1
8	F05006-43	4
9	S10060	1
10	S10061	1
5, 11-13	003224	1
5	P02720	1
11	P10051	2
12	P10053	1
13	P10377	1

14	S10140	1
15	P10052	1
16	P10065	1
17-18	016329	1
17	-----	1
18	P10065	1
19	S10059	1
20	S10089	1
21	F05004-43	4
22	F05006-28	4
23	P10147	1



## PARTIE 3 TÊTE DE SCIE

### 3.1 Vis Anti-Vibration

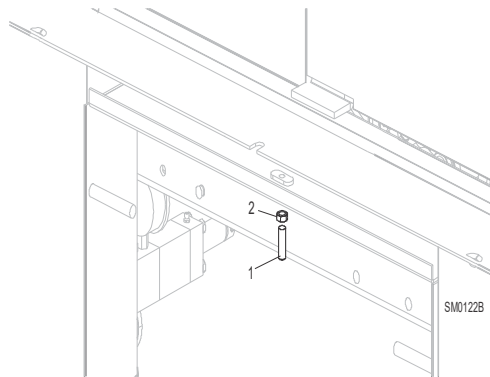

REF	PART #	QTY.
1	F05007-18	1
2	F05010-29	1

# 3 Tête De Scie

## Valve Du Contrôle De Lubrification

### 3.2 Valve Du Contrôle De Lubrification

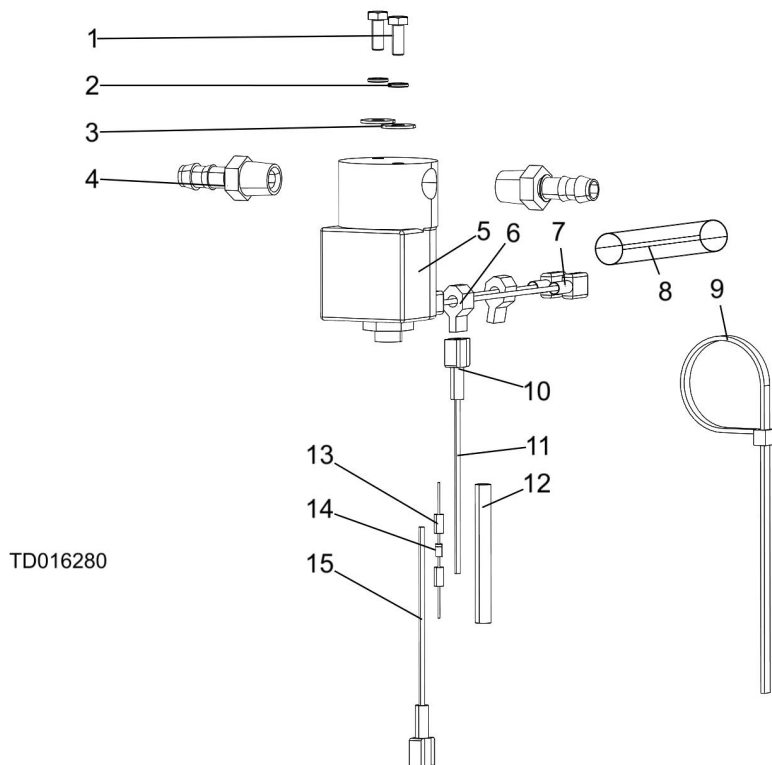

REF	PART #	QTY.
	016280	
1	F05004-60	2
2	F05011-20	2
3	F05011-18	2
4	P04682	2
	133071	1
5	016140	1
6	F04875-13	2
7	F05708-21R	2
8	R02374	1
9	F05089-3	1
	024123	1
10	F05708-22R	2
11	R01915-3_3	1
12	R01950-4_2_14	1
13	024032	2
14	E05909	1
15	R01915-0_3	1

**4** Saw Head  
Clutch Pivot

**4.3 Clutch Pivot**

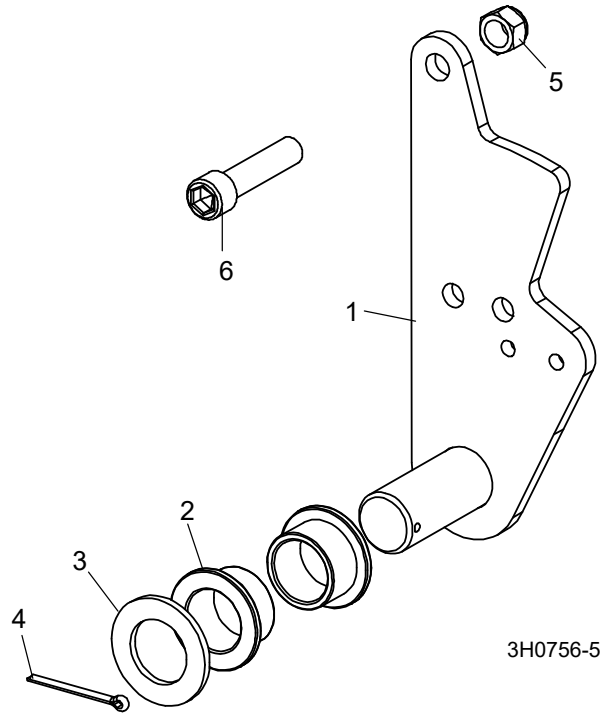

REF	DESCRIPTION (◆ Indicates Parts Available In Assemblies Only)	PART #	QTY.	
1	PLATE WELDMENT, CLUTCH PIVOT	016296	1	
2	BUSHING, CLUTCH/BRAKE PIVOT	P737	2	
3	WASHER, CLUTCH/BRAKE PIVOT	P116	1	
4	PIN, 1/8" X 1 1/2" COTTER	F05012-49	1	
5	NUT, 7/16-20 HEX NYLON LOCK	F05010-83	1	
6	BOLT, 7/16-20 X 2" SOCKET HEAD	F05007-120	1	

### 3.4 Fixation d'embrayage

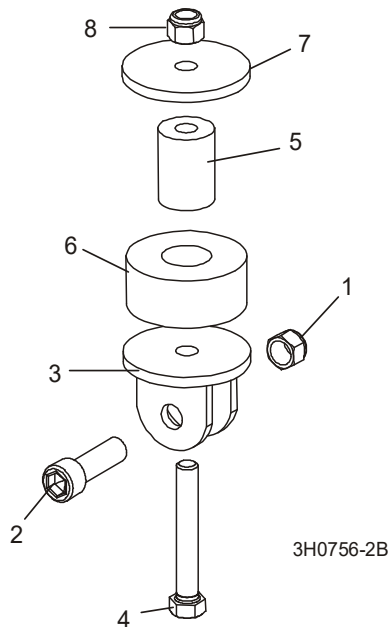

REF	PART #	QTY.
1	F05010-83	1
2	F05007-55	1
3	W12411	1
4	F05007-157	1
5	016316	1
6	P05032	1
7	021276	1
8	F05010-10	1

### 3.5 Système De Freinage

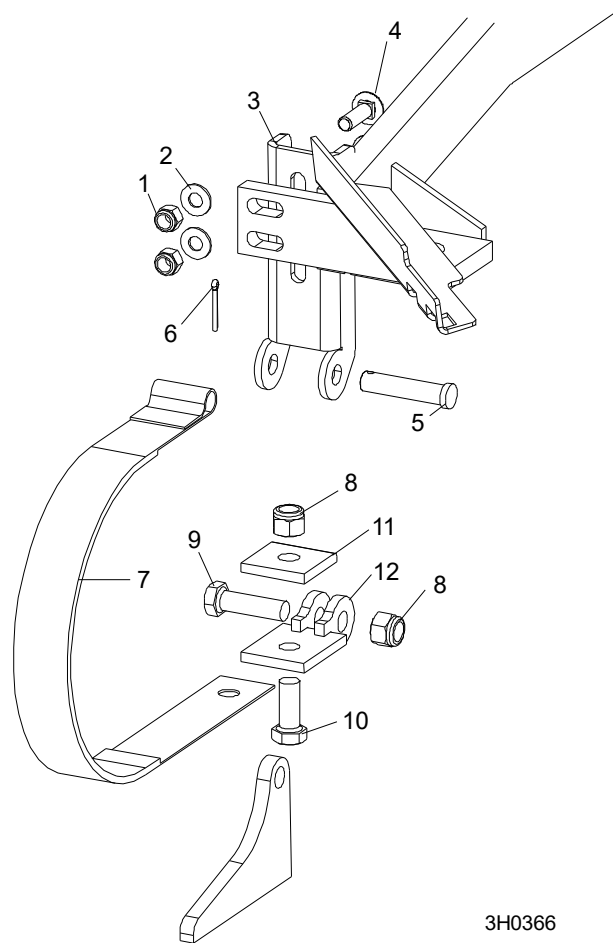

3H0366

REF	PART #	QTY.
1-12	014441	1
1	F05010-10	2
2	F05011-3	2
3	014395	1
4	F05007-127	2
5	F05012-81	1
6	F05012-1	1
7	014391	1
8	F05010-8	2
9	F05008-88	1
10	F05008-37	1
11	S04195	1
12	014392	1

### 3.13 Éjecteur De Planches (Optionnel)

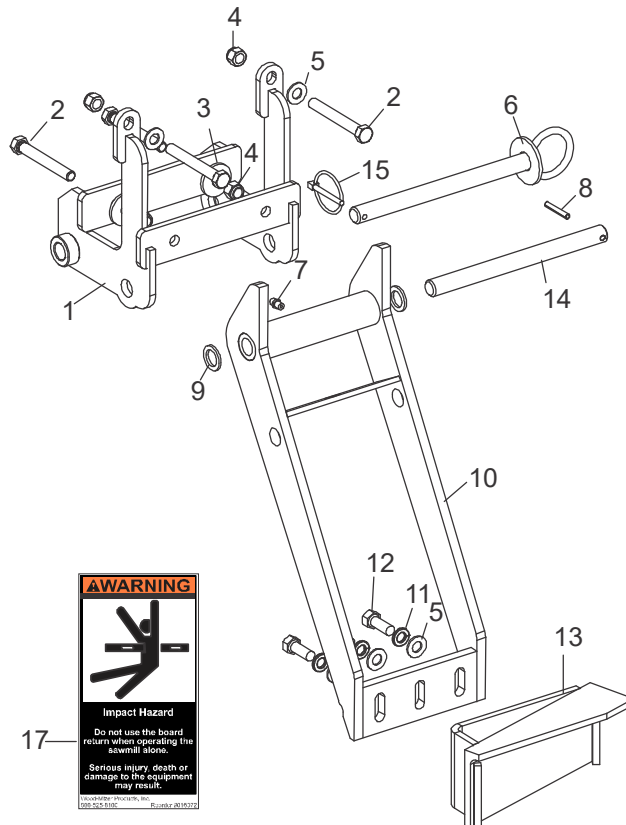
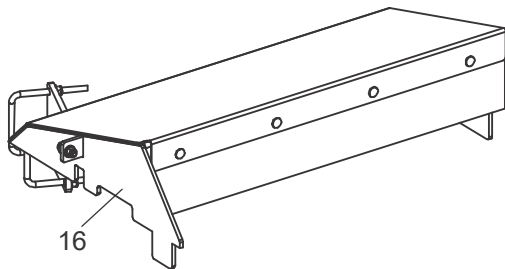
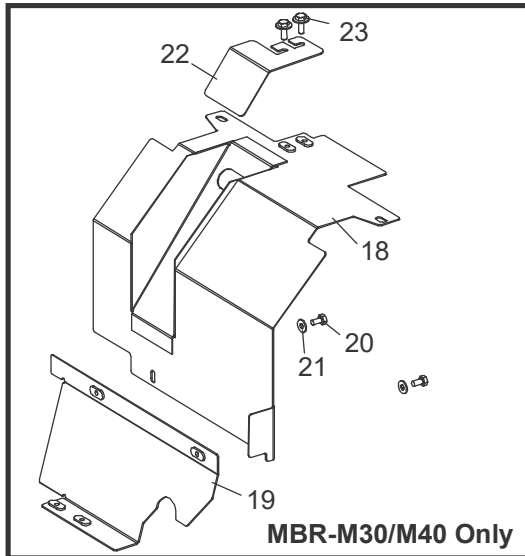

REF	PART #	QTY.
1-21	MBR-M30 <sup>1</sup>	1
	MBR-M40 <sup>2</sup>	1
1-21	MBR-A30 <sup>3</sup>	1
	MBR-A40 <sup>4</sup>	1
1-15	036693	1
1	036691	1
2	F05007-1	4
3	015336	2
4	F05010-10	4
5	F05011-3	5
6	036692	1
7	P05060	1
8	F05012-16	1
9	F05011-19	2

10	015210	1
11	F05011-4	3
12	F05007-7	3
13	015652	1
14	015225	1
15	017604	1
16	<a href="#">Voir Partie 7.10</a>	
17	016072-5	1
<b>Manual Seulement:</b>		
18	015657	1
19	015678	1
20	F05005-15	2
21	F05011-11	2

<sup>1</sup> LT30 Manual  
<sup>2</sup> LT40 Manual

<sup>3</sup> LT30 (L'option de l'embrayage automatique)  
<sup>4</sup> LT40 (L'option de l'embrayage automatique)

### 3.6 Système De Lubrification (Gas)

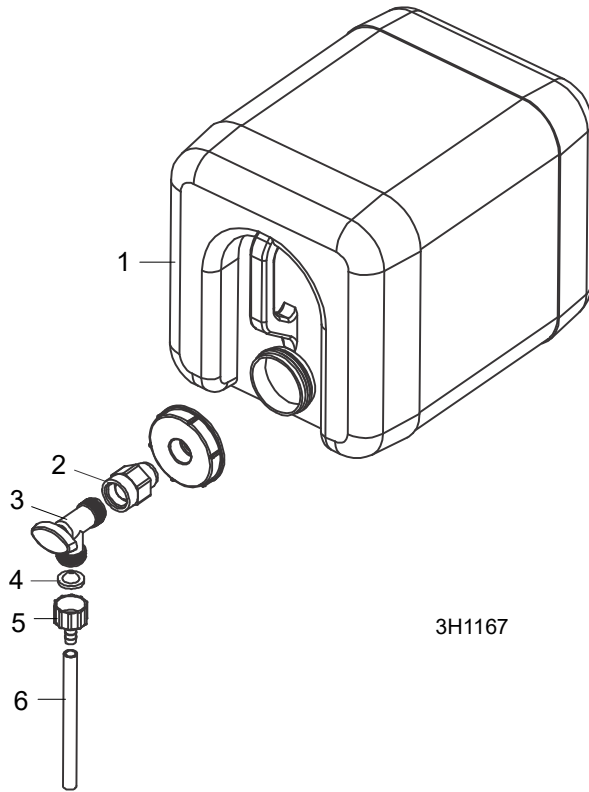

REF	PART #	QTY.
1	014642	1
2	014636	1
3	014100	1

4	016086	1
5	014113	1
6	R01885	7 ft.
	CBOTTLE	1

### 3.7 Système De Lubrification (Diesel & Electric)

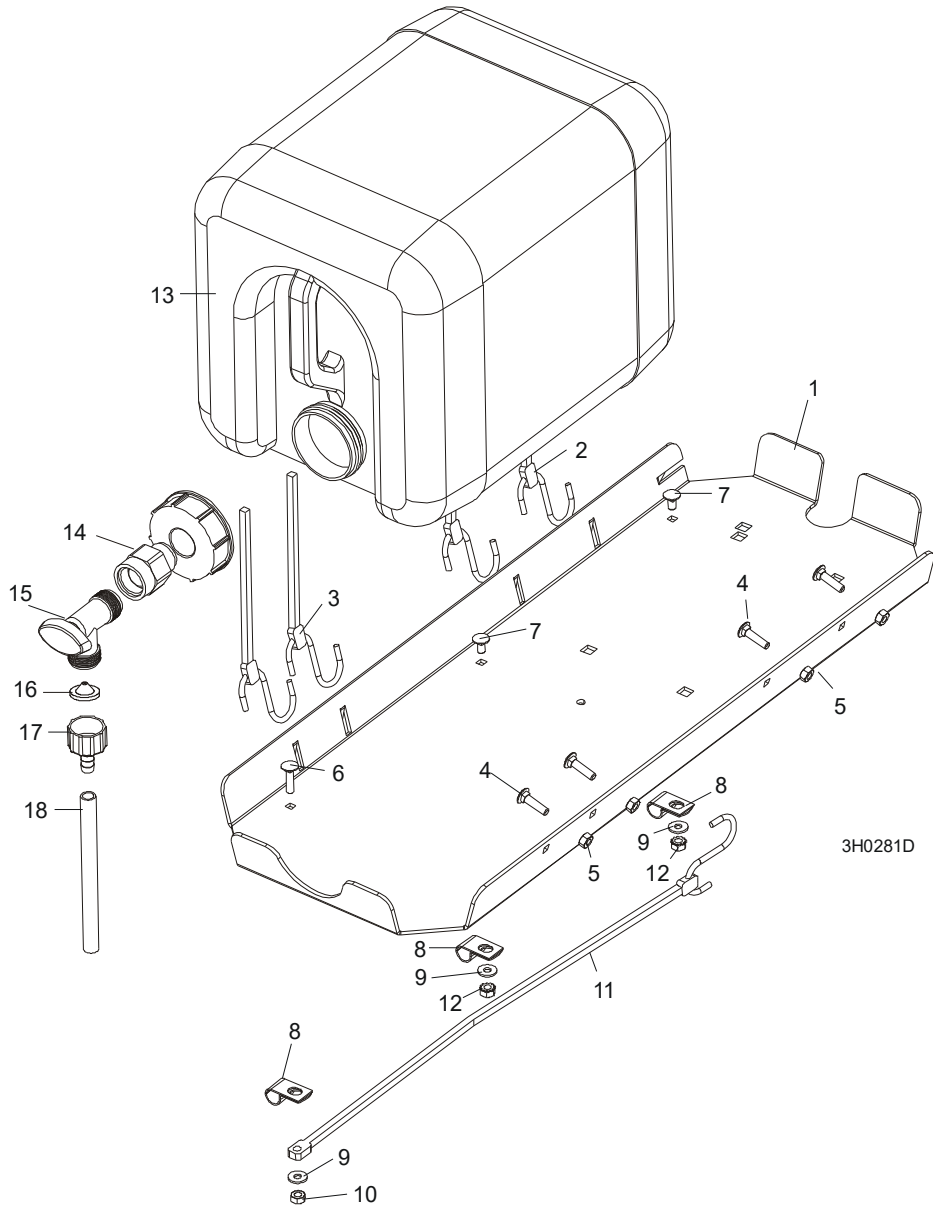

REF	PART #	QTY.
1-5	A11685	1
1	S11684	1
2	P11258	2
3	P11668	2
4	F05005-34	4
5	F05010-21	4

6	F05005-34	1
7	F05005-33	2
8	P07584	3
9	F05011-11	3
10	F05010-21	1
11	P07461	1
12	F05010-9	2
13	014642	1

14	014636	1
15	014100	1
16	016086	1
17	014113	1
18	R01885	7 ft.



### 3.8 Étiquettes D'avertissement

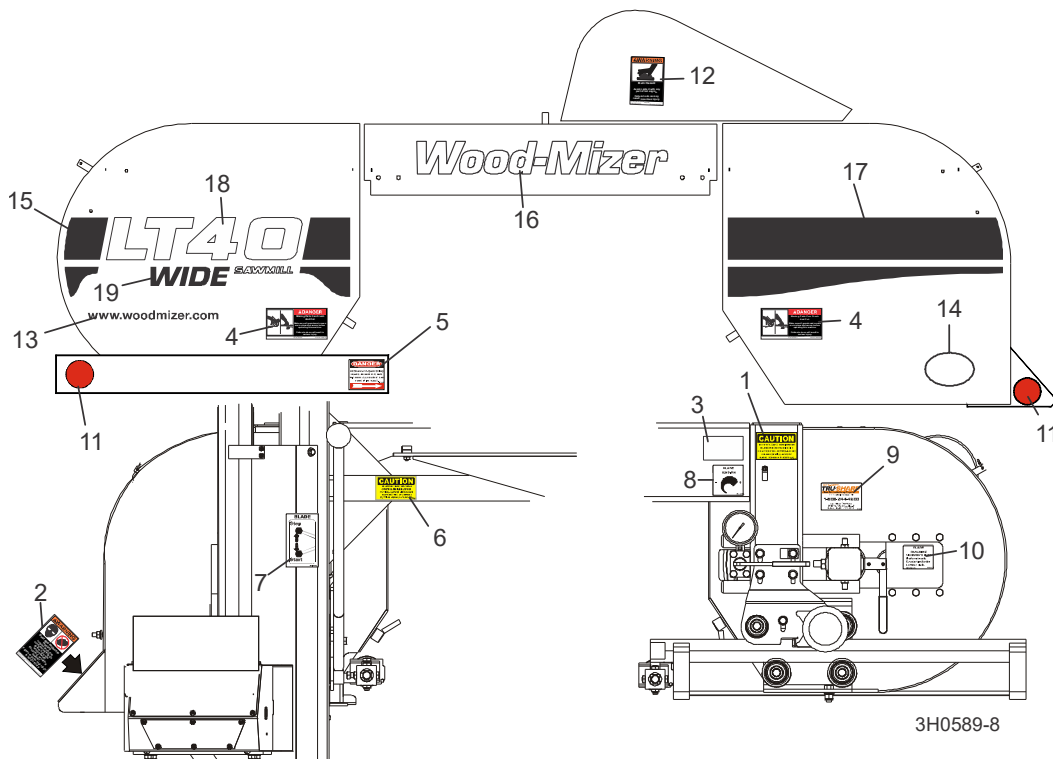

REF	PART #	QTY.
1	P10147	1
2	P11754	1
3	P12373	1
4	033254	2
5	S11752	1
6	S11762	1
7	P11779	1
8	P11790	1
9	P12879	1
10	P11789	1
11	P07452	2
12	014419	1
13	003235	1
14	065582	1
15	065023	1
16	065025	1
17	065026	1
18	065024	1
19	074335	1

### 3.9 Couvercles De Carters De Lame

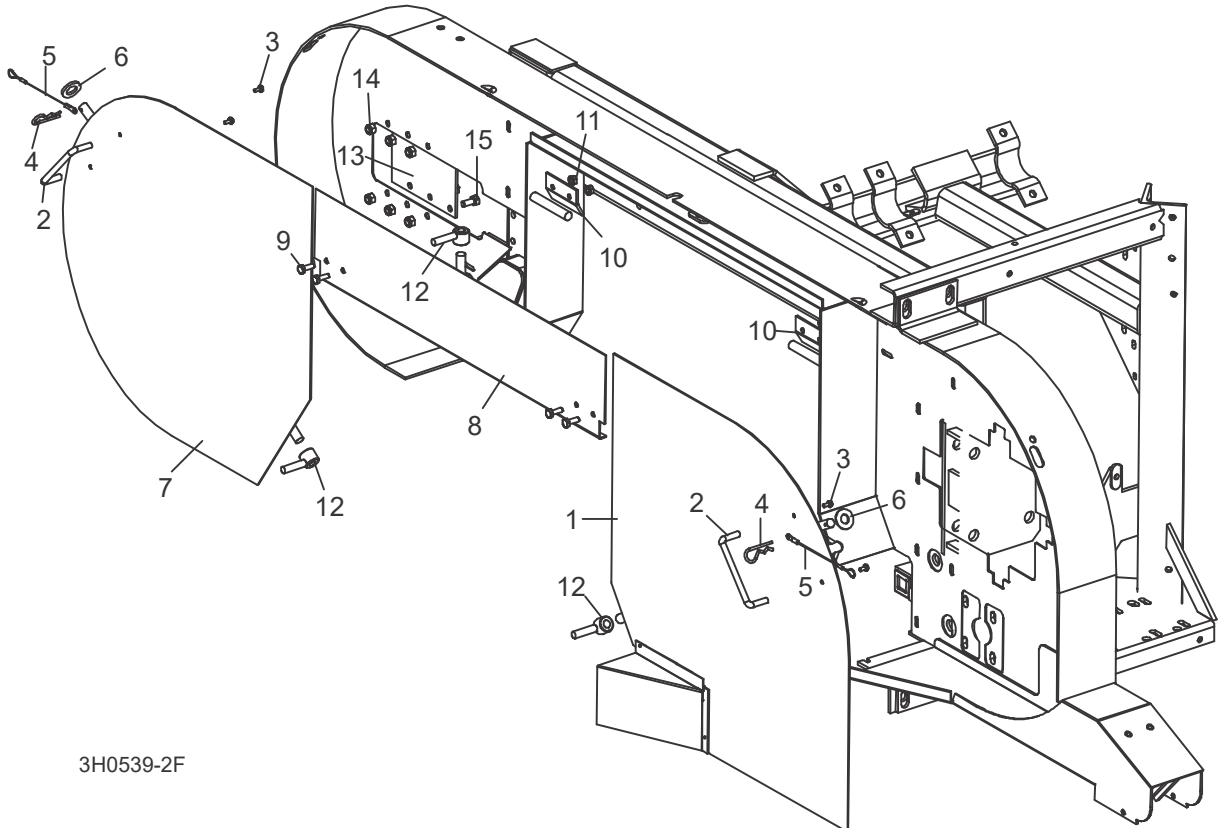

3H0539-2F

REF	PART #	QTY.
1-8	015937	1
1	----	1
2	P08065	1
3	F05015-8	2
4-5	A12812	1
4	P05059	1
5	016030	1
6	F05011-87	1

2-5, 6-7	A09419	1
7	----	1
2	P08065	1
3	F05015-8	2
	A12812	1
4	P05059	1
5	016030	1
8	F05011-87	1
8	W07409	1

8	079509 (Wide)	1
9	F05005-1	18
10	S07522	2
11	F05010-9	4
12	021145	3
13	S04433	1
14	F05010-58	6
15	F05006-5	6

### 3.10 Couvercles De Carters De Courroies

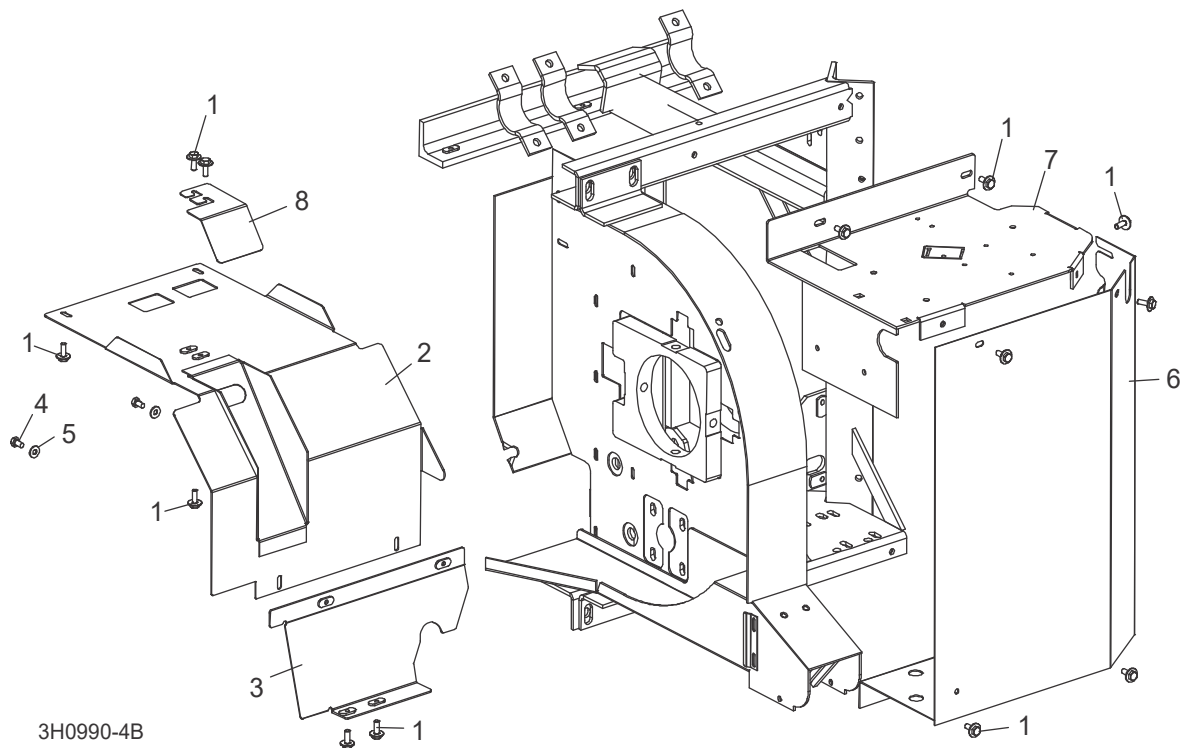

REF	PART #	QTY.
1	F05005-134	11
2	006028	1
3	006025	1
4	F05005-15	2
5	F05011-11	2
6	059596	1
7	059599	1
8	074752	1

### 3.11 Chute À Bran De Scie

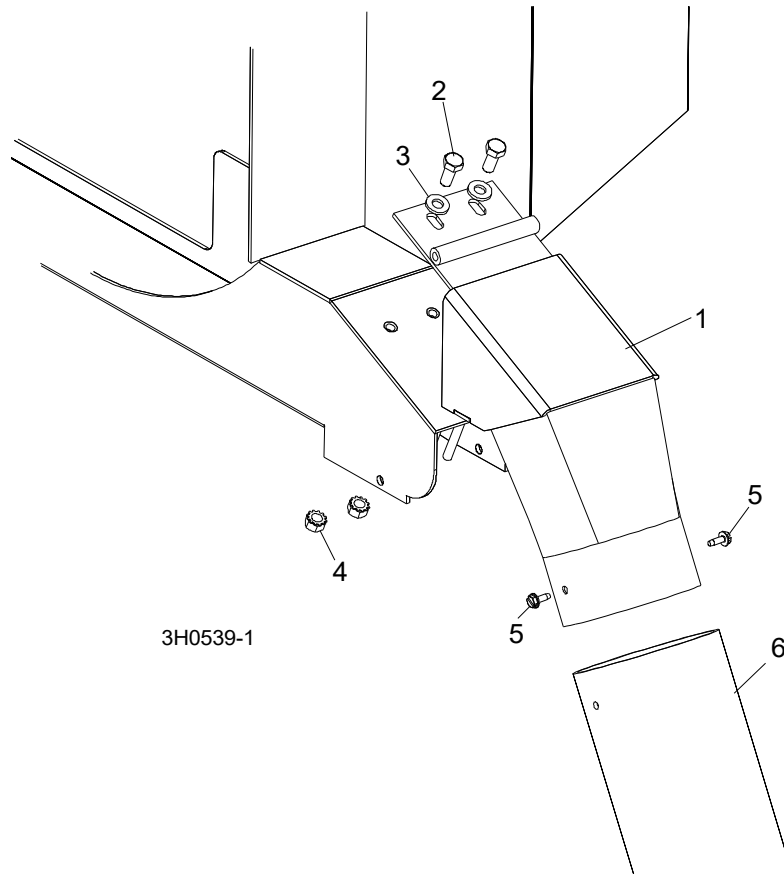

REF	PART #	QTY.
1	015466	1
2	F05006-5	2
3	F05011-17	2
4	F05010-20	2
5	F05015-7	2
6	016727	1

### 3.12 Boîte De Filage De L'écorceuse Et Obturateurs

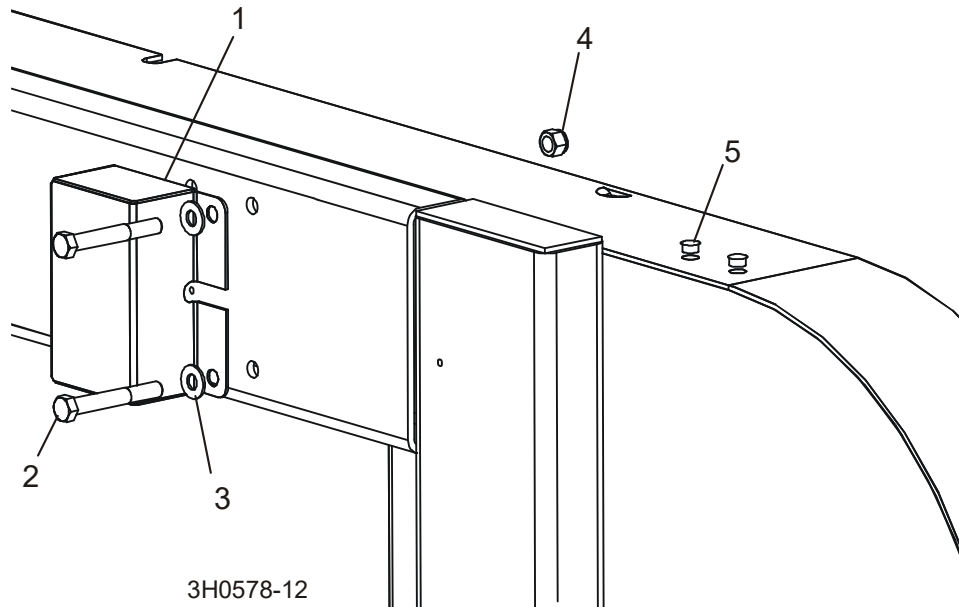

REF	PART #	QTY.
1	023616	1
2	F05007-29	2
3	F05011-3	2
4	F05010-10	2
5	014537	2

# 4 Système De Commande Et Batterie

## PARTIE 4 SYSTÈME DE COMMANDE ET BATTERIE

### 4.1 Système De Commande

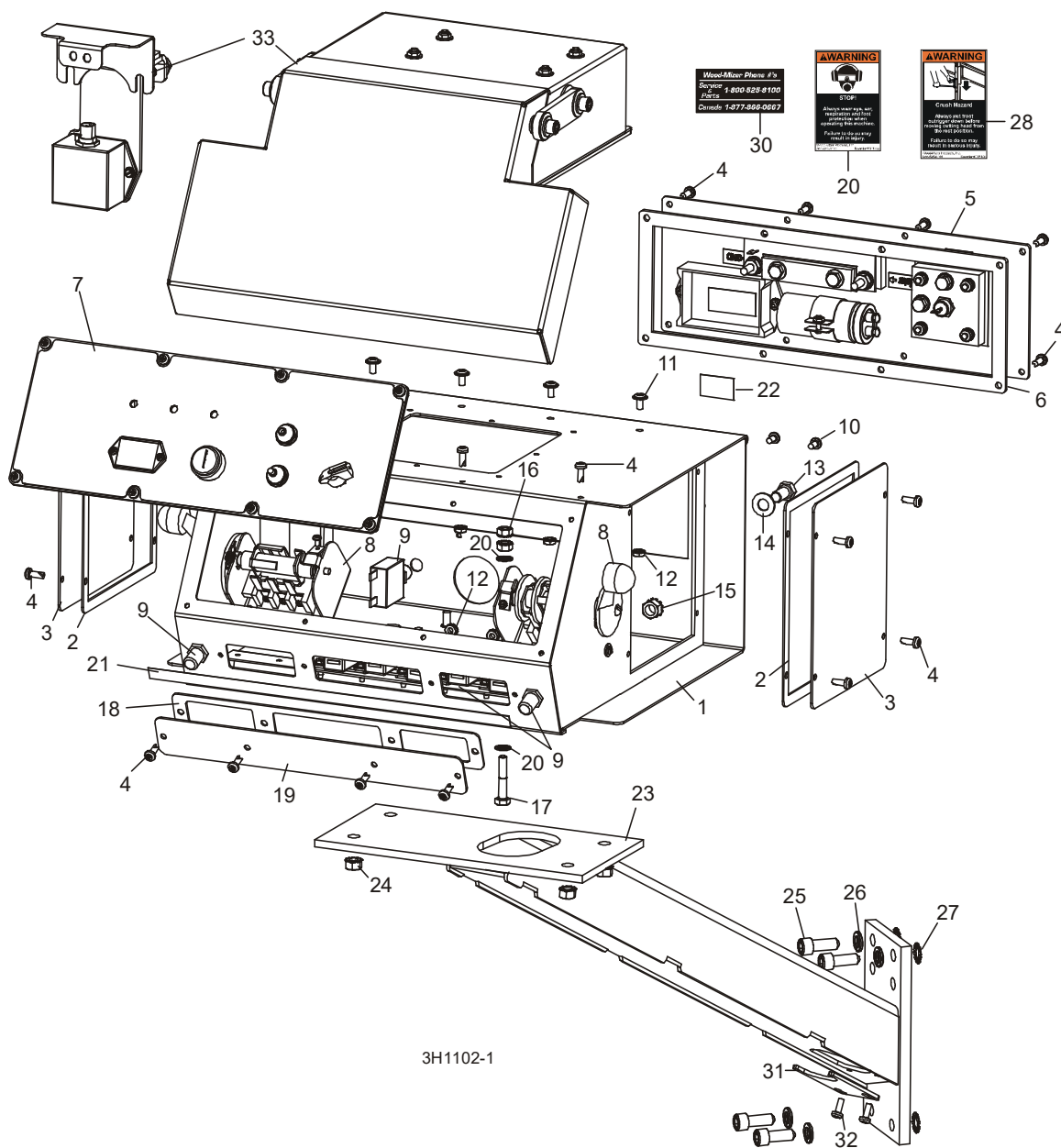

REF	PART #	QTY.
	015764	1
	036352	1

	069534	1
	069323	1
	069321	1
	069322 <sup>1</sup>	1
<b>1</b>	016135	1
<b>2</b>	F05015-17	24
<b>3</b>	015274	2
<b>4</b>	006473	2
<b>5</b>	024458	1
	024396-1	1
	052294	1
	024387	1
	051571	1
	052363	1
<b>6</b>	015278	1
<b>7</b>		
<b>8</b>		
<b>9</b>		
<b>10</b>	F05004-3	2
<b>11</b>	F05004-148	4
<b>12</b>	F05010-14	6
<b>13</b>	F05007-27	1
<b>14</b>	F05011-3	1
<b>15</b>	F05010-19	1
<b>16</b>	F05010-9	2
<b>17</b>	F05005-181	1
<b>18</b>	015266	1
<b>19</b>	015376	1
<b>20</b>	F05011-69	2
<b>21</b>	069349	1
<b>22</b>	024366	1
<b>23</b>	015236	1
<b>24</b>	F05010-20	4
<b>25</b>	F05007-52	4
<b>26</b>	F05011-4	4
<b>27</b>	F05011-36	4
<b>28</b>	015400	1
<b>29</b>	S11753	1
<b>30</b>	S12117	1
<b>31</b>	036381	1
<b>32</b>	F05015-17	2
<b>33</b>		

<sup>1</sup> Replaced with D35 Tier4 Control Box Assembly for the U.S. only (Rev. K7.00+). See Section Control Assembly (D35 Tier4 Only).

# 4 Control & Battery Boxes

## 4.2 Systeme De Commande (Tier4 Seulement)

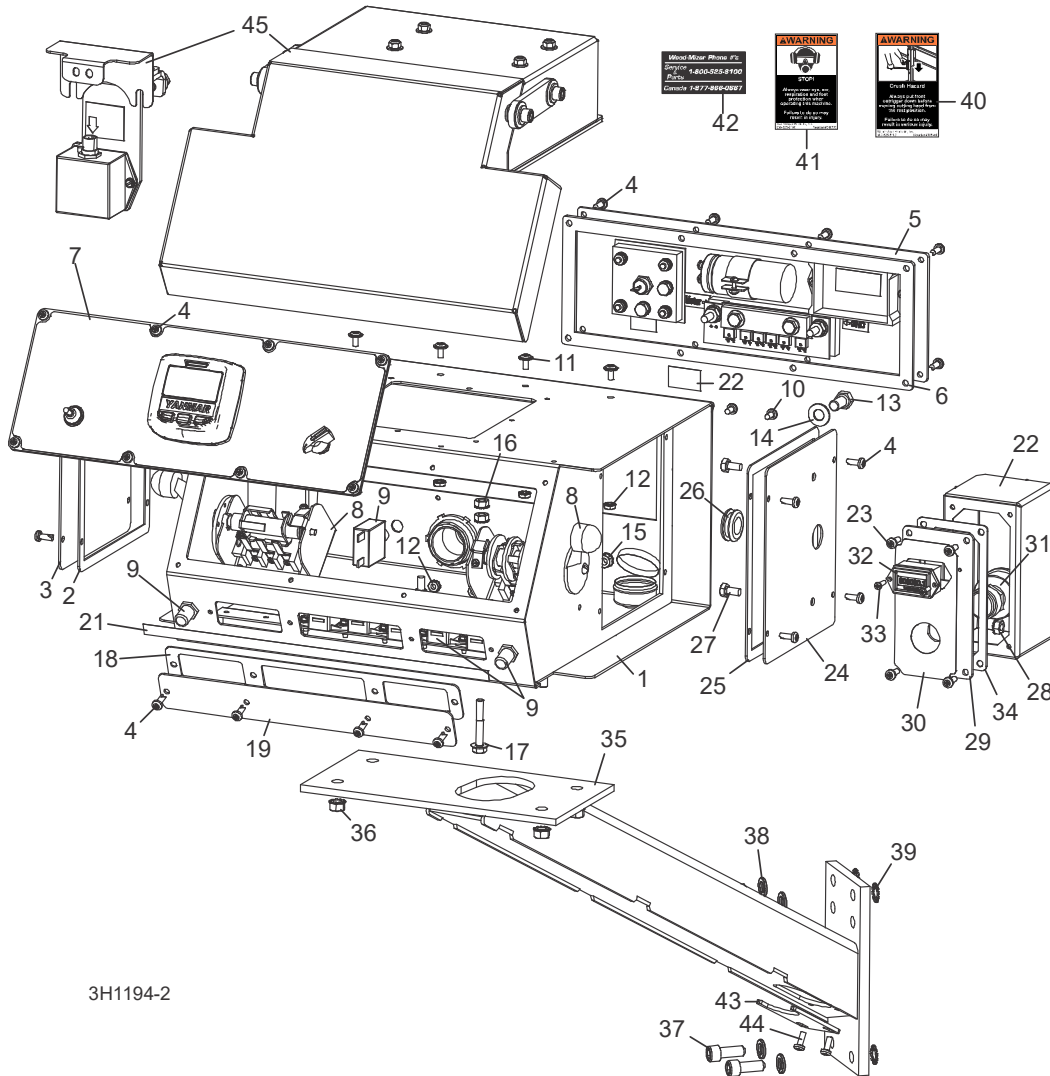

3H1194-2

REF	PART #	QTY.	
	015764	1	
	036352	1	
	073608	1	
1	016135	1	◆
2	F05015-17	24	
3	015274	2	
4	006473	2	
5	024458	1	
	024396-2	1	
	052294	1	
	024387	1	

	052365	1	
	052363	1	
6	015278	1	
7			
8			
9			
10	F05004-3	2	
11	F05004-148	4	
12	F05010-14	6	
13	F05007-27	1	
14	F05011-3	1	
15	F05010-19	1	

16	F05010-9	2	
17	F05005-181	1	
18	015266	1	
19	015376	1	
20	069349	1	
21	024366	1	
	073603	1	
22	078426	1	
23	F05015-17	4	
24	033495	1	
25	015274	1	
26	033475	1	



<b>27</b>	F05005-15	2	
<b>28</b>	F05010-9	2	
	073597	1	
<b>29</b>	073598	1	
<b>30</b>	073594	1	
<b>31</b>	P04350	1	
<b>32</b>	015401	1	
<b>33</b>	F05015-28	2	

<b>34</b>	033488	1	
<b>35</b>	015236	1	
<b>36</b>	F05010-20	4	
<b>37</b>	F05007-52	4	
<b>38</b>	F05011-4	4	
<b>39</b>	F05011-36	4	
<b>40</b>	015400	1	
<b>41</b>	S11753	1	

<b>42</b>	S12117	1	
<b>43</b>	036381	1	
<b>44</b>	F05015-17	2	
<b>45</b>			

**4.3 Commutateurs**

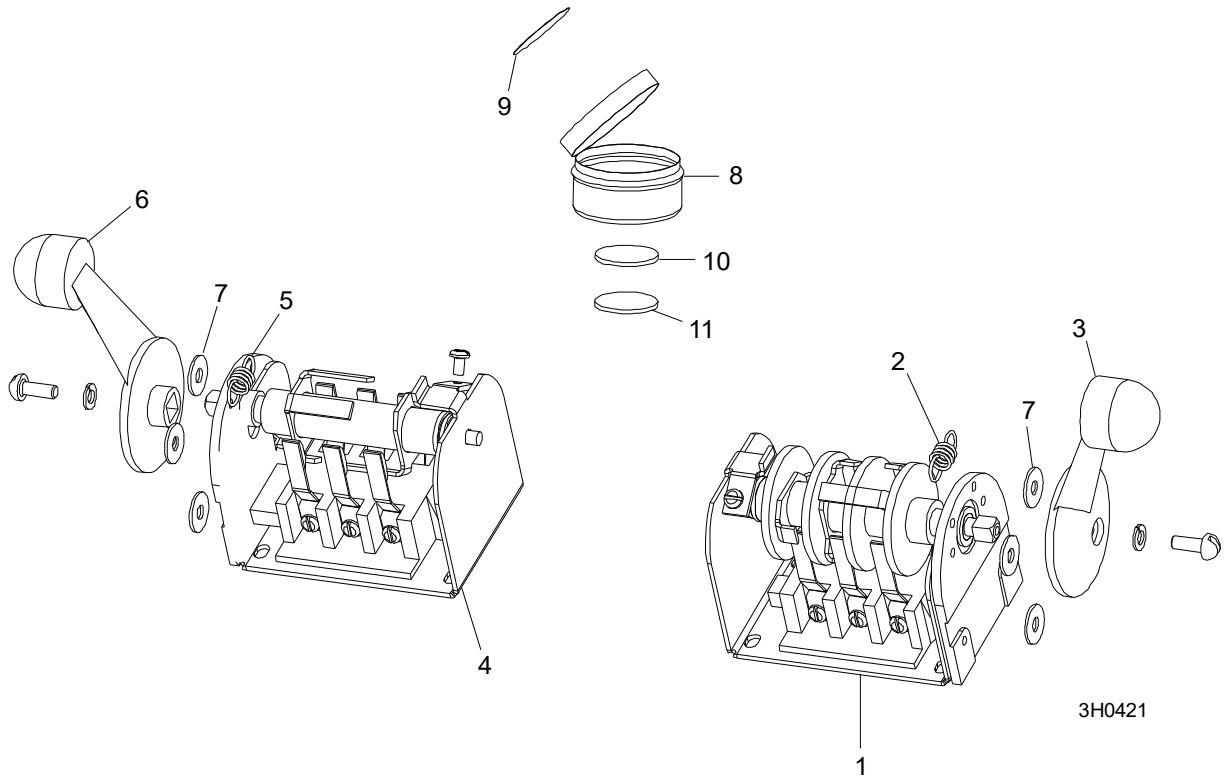

REF	PART #	QTY.
1-3	E20440	1
1	-----	1
2	P12570	1
3	P12500	1
4-6	E20439	1

4	-----	1
5	P12570	1
6	P12500	1
7	F05011-41	6
9-12	A20463	1
8	-----	1

9	P20467	1
10	-----	1
11	-----	1

## 4.4 Disjoncteurs

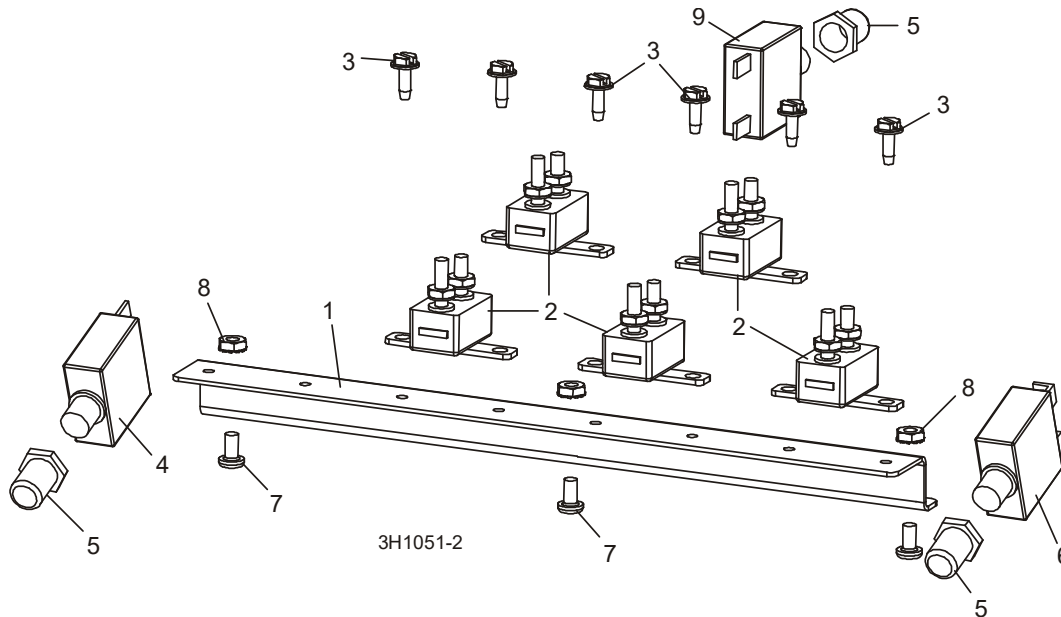

REF	PART #	QTY.
1-3	015621	1
1	052826	1
2	E20430	5

3	F05015-7	6
4	051981	1
5	021253	3
6	021256	1

7	F05004-3	3
8	F05010-14	3
9	024246	1

# 4 Systeme De Commande Et Batterie

## Panneau De Commande

### 4.5 Panneau De Commande

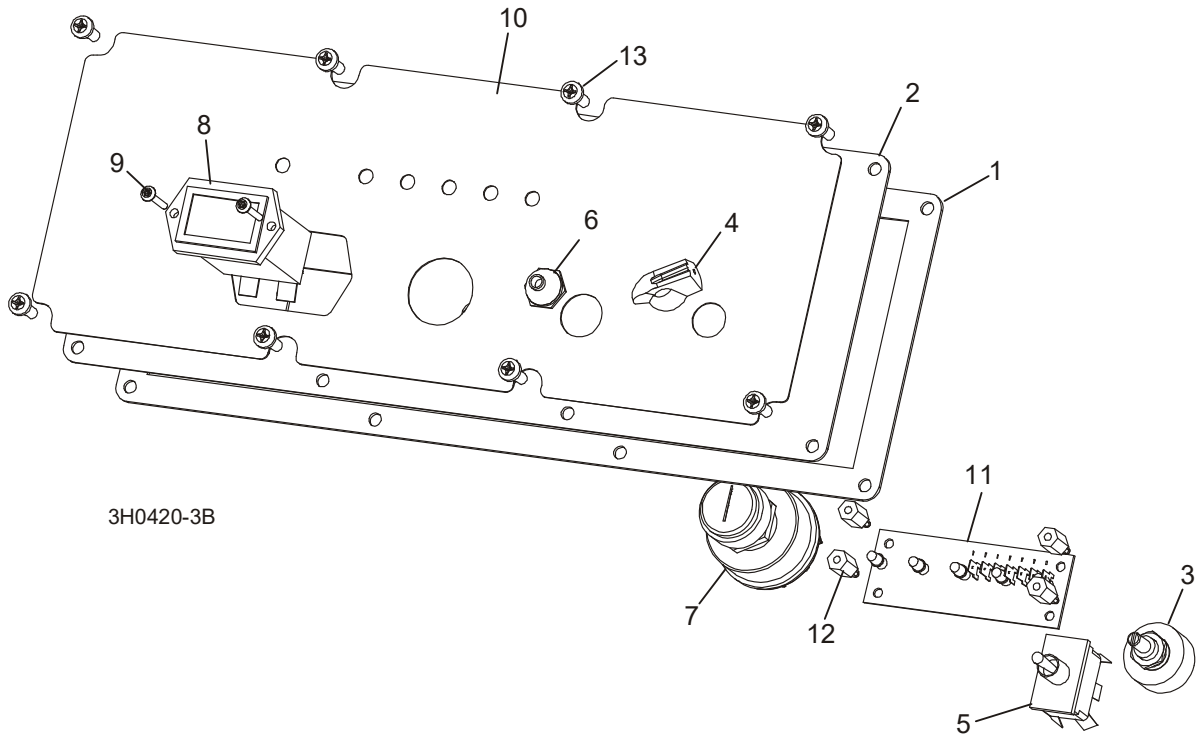

REF	PART #	QTY.	
	024210	1	
	024211	1	
1	015270	1	
2	015302	1	
3	024450-1	1	
4	P06257	1	
5	024200	1	
6	P02575	1	
7	P04350	1	
8	015401	1	
9	F05015-28	2	
10	015271	1	
	015269	1	
11	015416	1	
	015409	1	
12	023147	4	
13	F05015-17	8	

	069531	1	
	069305	1	
	069303		
	069304	1	
	050399	1	
	024402	1	
	050679	1	
	050678	1	
	R02374	41 in.	
	R02374	42 in.	

**4** Control & Battery Boxes  
*Panneau De Commande (Tier4 Seulement)*

**4.6 Panneau De Commande (Tier4 Seulement)**

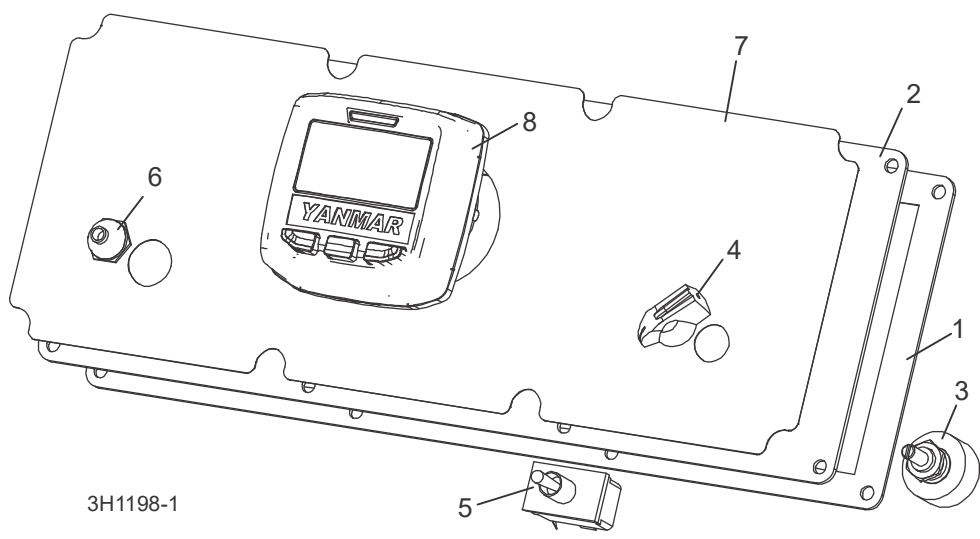

REF	PART #	QTY.	
	073610	1	
1	015270	1	
2	011298	1	
3	024450	1	
4	P06257	1	
5	024200	1	
6	P02575	1	
7	073593	1	
8	073601	1	
	073609	1	
	050399	1	
	024402	1	
	073619	1	
	R02374	41 in.	
	R02374	42 in.	

## 4.7 Boîte De Batterie

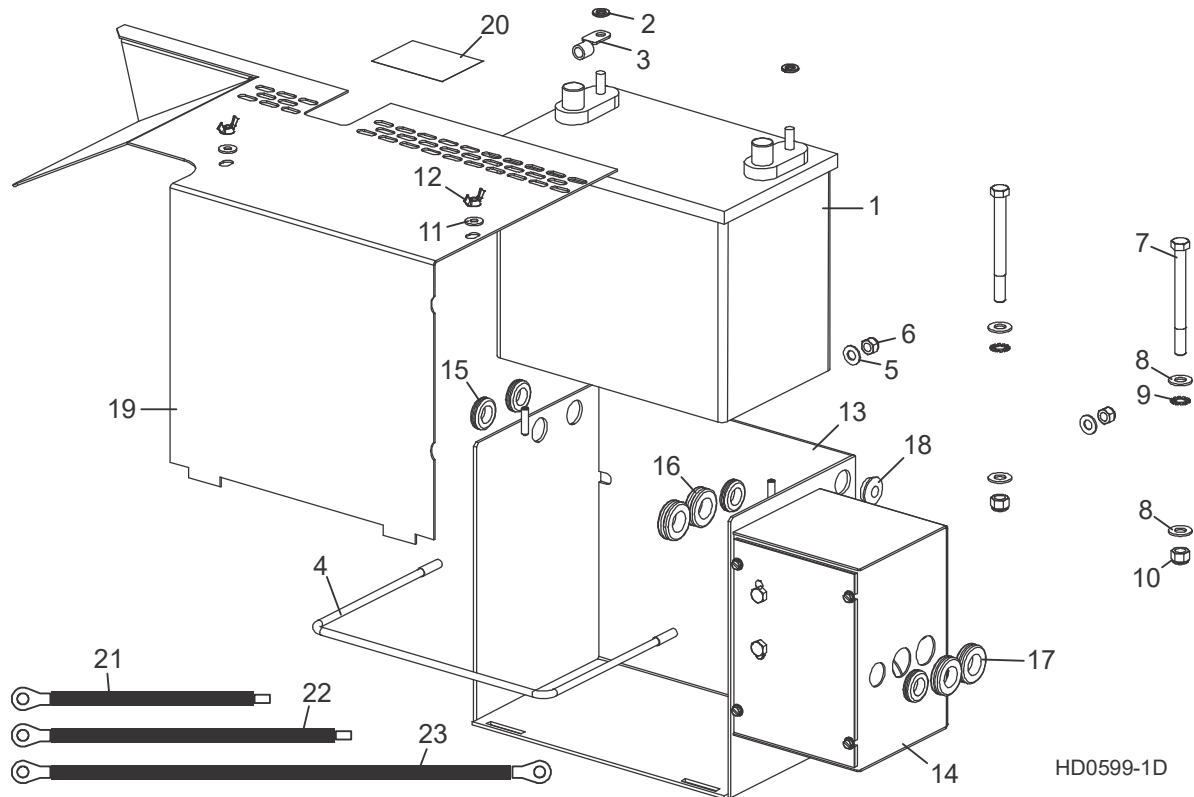

REF	PART NUMBER	QTY.
1	P12315	1
2-18	015471	1
2	F05011-13	2
3	F05092-16	1
4	P09790	1
5	F05011-17	2
6	F05010-58	2
7	F05007-4	2
8	F05011-3	2
9	F05011-36	2
10	F05010-10	2
11	F05011-11	2
12	F05010-13	2
13	015472	1
14	<a href="#">Voir Partie 4.8</a> <a href="#">Voir Partie 8.2</a>	
15	P11764	4

16	074198	2
17	074199	2
18	052496	1
19	015774	1
20	014774	1
21	036308	1
22	036309	1
23	036306	1

# 4 Système De Commande Et Batterie

## Boîte De Fusibles

### 4.8 Boîte De Fusibles

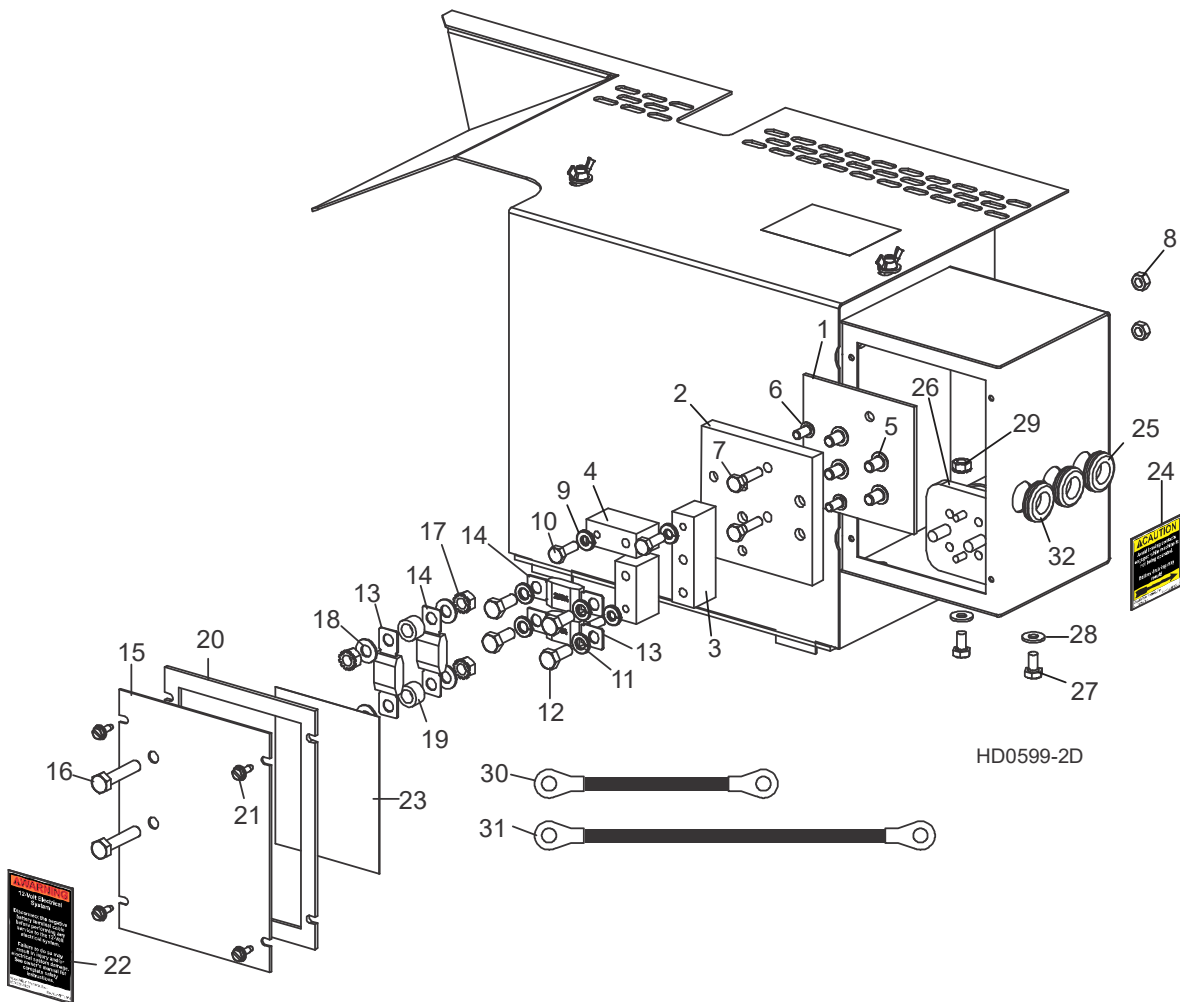

REF	PART #	QTY.
1-12	006795	1
1	056999	1
2	-----	1
3	056996	1
4	056998	2
5	F05006-20	4
6	F05005-59	2
7	F05005-101	2
8	F05010-21	2
9	F05011-14	3
10	F05005-123	3
11	F05011-13	4

12	F05006-102	4
13	052370-150	2
14	053339	2
16-20	006853	1
15	006851	1
16	F05006-2	2
17	F05010-20	4
18	F05011-17	4
19	055323	2
20	050283	1
21	F05015-7	4
22	P10364-5	1
23	006867	1

24	P12960-5	1
25	074199	2
26	016371	1
27	F05005-15	2
28	F05011-11	2
29	F05010-9	2
30	036305	1
31	036307	1
32	P11764	1



## PARTIE 5 SYSTÈME DE MONTÉE

### 5.1 Fixation De La Tête De Sciage

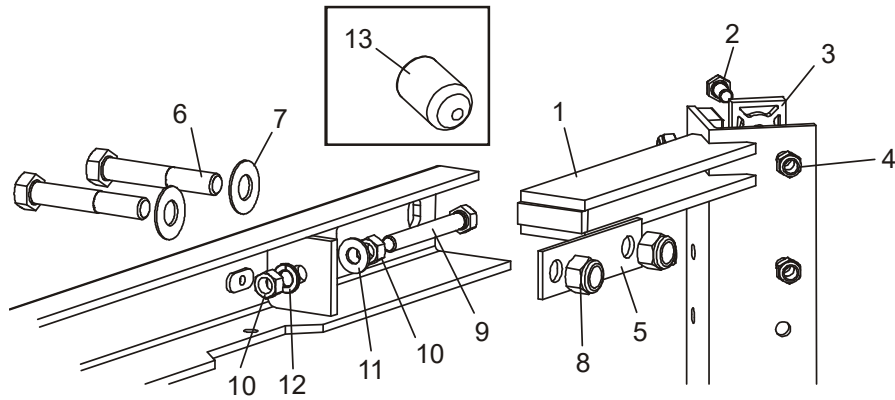

SM0080D

REF	PART #	QTY.
1	W04099	1
2	F05006-5	12
	F05006-93	4
3	M04096	6
	016241	2

4	F05010-58	16
5	S07935	2
6	F05008-61	4
7	F05011-2	4
8	F05010-8	4
9	F05007-17	2

10	F05010-1	4
11	F05011-3	2
12	F05011-4	2
13	017715	3

## 5.2 Indicateur De Hauteur Et Règles De Débitage

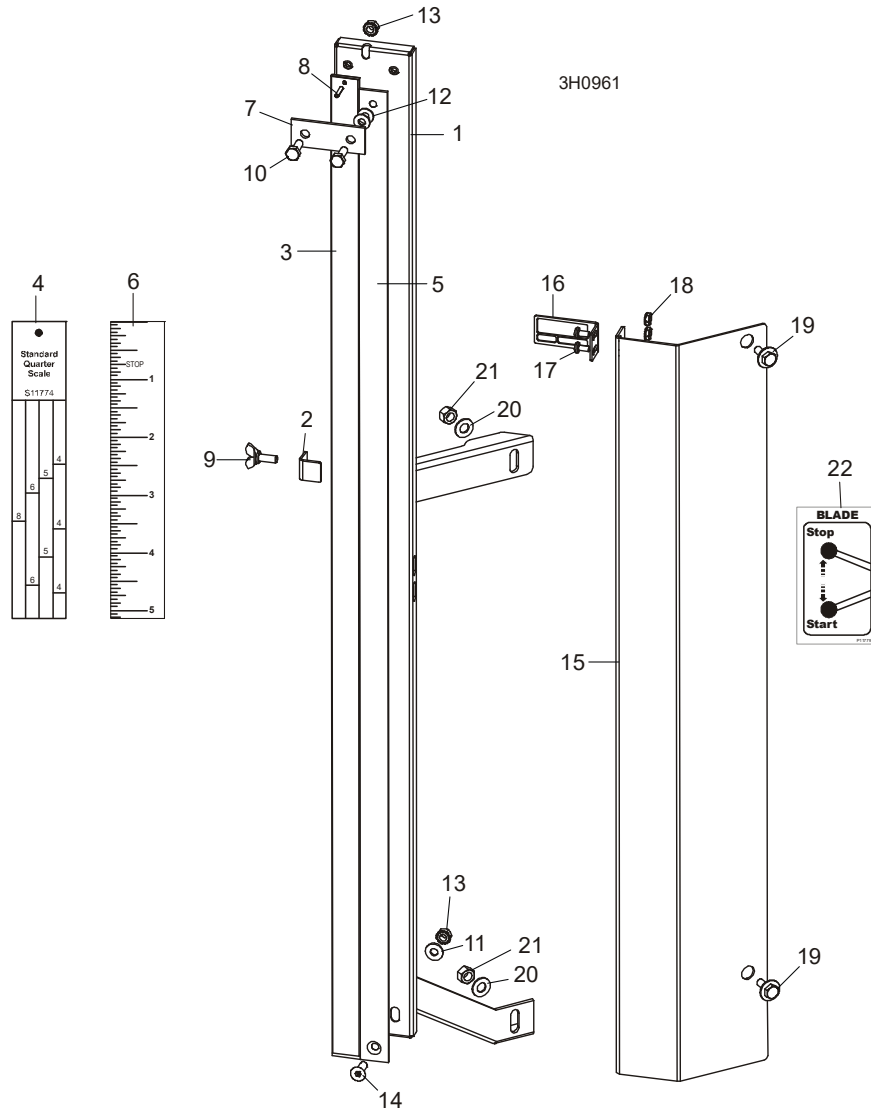

REF	PART #	QTY.
1-21	A12030	1
1-21	----	1
1-14	----	1
1-2	W11996	1
2	036666	1
3-4	S11989	1
4	S11774 <sup>1</sup>	1
	P12819 <sup>2</sup>	1
5-6	S11988	1

6	S11773	1
7	S04805	1
8	F05012-14	1
9	F05005-64	1
10	F05005-1	2
11	F05011-11	1
12	F05011-22	2
13	F05010-9	2
14	F05005-70	1
15-18	038591	1

15	038586	1
16	038585	1
17	F05004-3	2
18	F05010-14	2
19	F05005-134	2
20	F05011-17	2
21	F05010-6	2
22	P11779-5	1

<sup>1</sup> Standard

<sup>2</sup> Pour Bois Dur

### 5.3 Chaînes Et Pignons De Montée

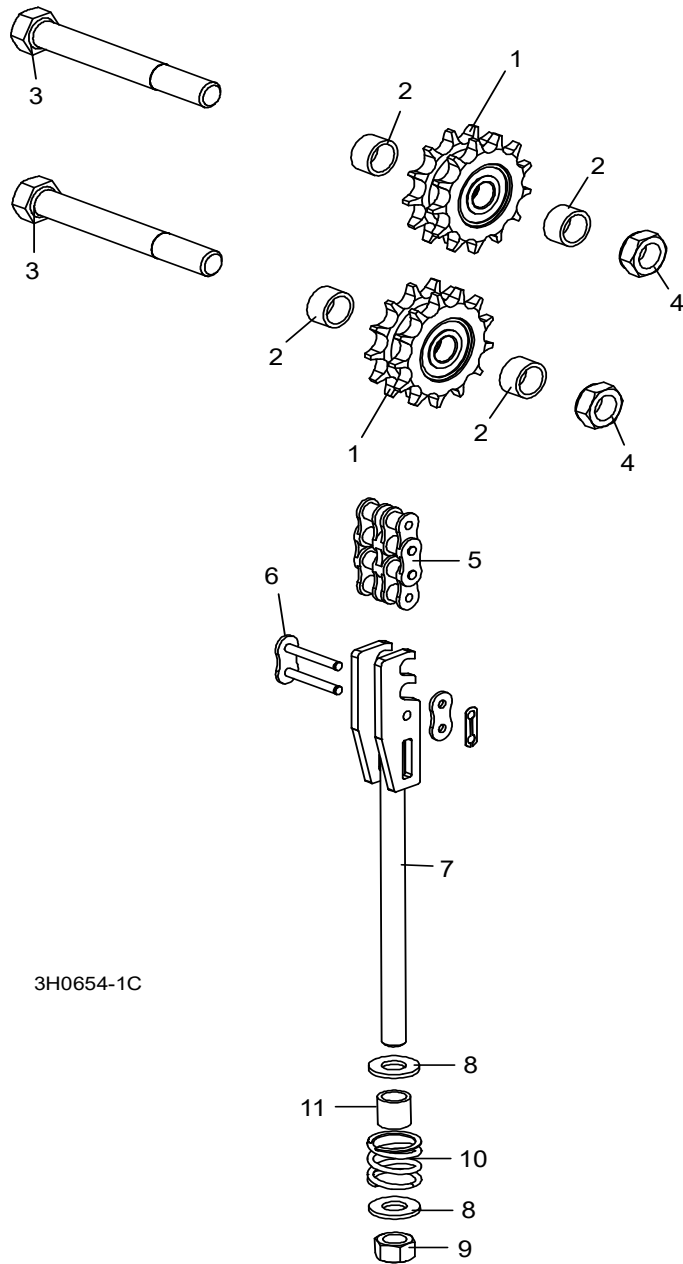

3H0654-1C

REF	PART #	QTY.
1-2	016020	1
1	016019	2
2	016018	4
3	F05009-6	2
4	F05010-96	2

5	015259	1
6	015258	2
7-11	015456	1
7	015188	1
8	F05011-2	2
9	F05010-8	1

10	016516	1
11	016515	1

## 5.4 Moteur De Montée

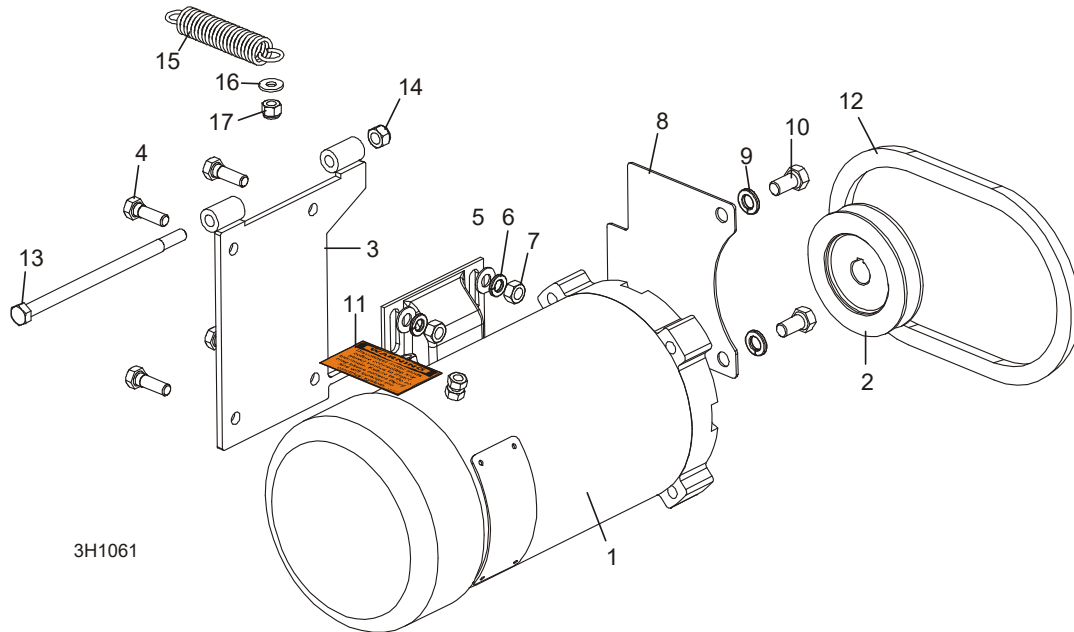

REF	PART #	QTY.
1 - 11	008779	1
1	053682	1
2	008999	1
3	015198	1
4	F05006-1	4
5	F05011-17	4
6	F05011-13	4
7	F05010-17	4
8	015016	1
9	F05011-4	2
10	F05007-27	2
11	024431	1
12	038459	1
13	F05006-73	1
14	F05010-65	1
15	015569	1
16	F05011-11	1
17	F05010-69	1

## 5.5 Système D'entraînement De Montée

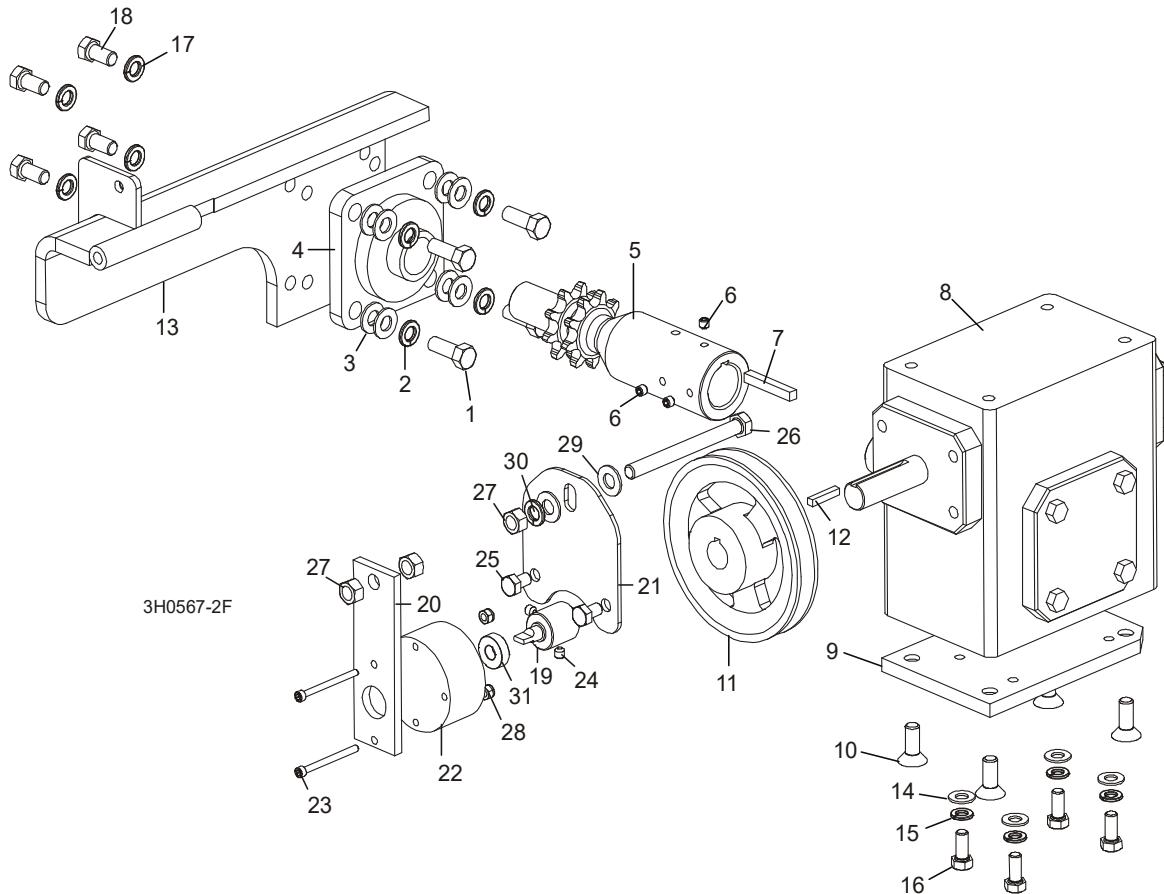

REF	PART #	QTY.
<b>1-13</b>	015176	1
<b>1</b>	F05007-7	4
<b>2</b>	F05011-4	4
<b>3</b>	F05011-3	8
<b>4</b>	014090	1
<b>5-7</b>	016094	1
<b>5</b>	----	1
<b>6</b>	F05005-105	3
<b>7</b>	S04124	1
<b>8</b>	074124	1
<b>9</b>	014158	1
<b>10</b>	F05007-64	4
<b>11</b>	015256	1
<b>12</b>	S31027	1
<b>13</b>	015195	1

<b>14</b>	F05011-17	4
<b>15</b>	F05011-13	4
<b>16</b>	F05006-102	4
<b>17</b>	F05011-4	4
<b>18</b>	F05007-27	4
<b>19-31</b>	065187	1
<b>19</b>	062511	1
<b>20</b>	062513	1
<b>21</b>	065190	1
	065907	1
<b>22</b>	069519	1
	F05708-26	2
<b>23</b>	F05004-273	2
<b>24</b>	F05005-131	2
<b>25</b>	F05006-15	2
<b>26</b>	F05007-92	1

<b>27</b>	F05010-1	3
<b>28</b>	F05010-169	2
<b>29</b>	F05011-3	2
<b>30</b>	F05011-4	1
<b>31</b>	P10688	1

## PARTIE 6 SYSTÈME D'ENTRAÎNEMENT ET PALIERS

### 6.1 Paliers de Rail Superieur et Grattoirs

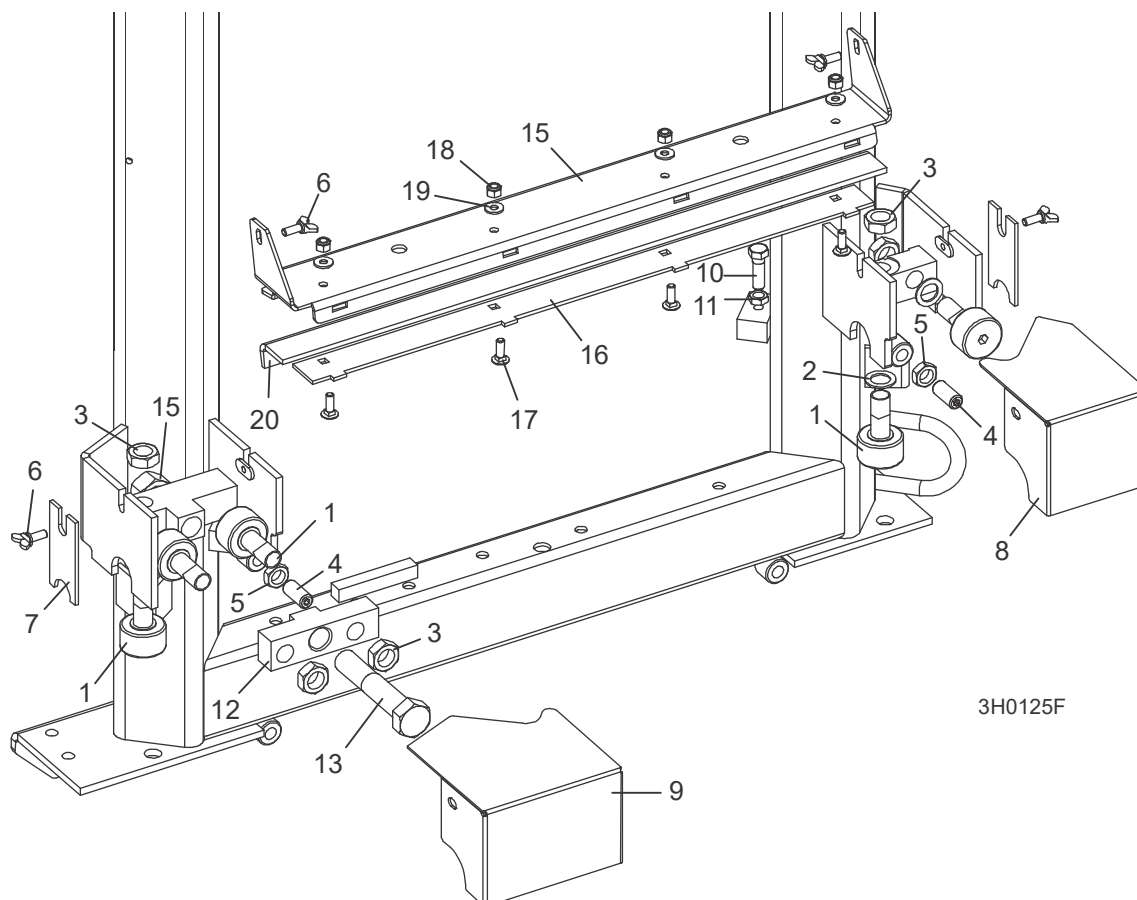

3H0125F

REF	PART #	QTY.
1	012797	5
2	016510	2
3	F05010-11	5
4	F05008-5	2
5	F05010-31	2
6	F05005-64	4
7	M04113	2
8	012999	1
9	016285	1
10	F05007-2	2
11	F05010-29	2
12	016501	1
13	F05013-3	1

## **6** Système D'entraînement Et Paliers

*Paliers de Rail Superieur et Grattoirs*

---

<b>14</b>	F05010-80	1	
	110612	1	
<b>15</b>	110609	1	◆
<b>16</b>	110611	1	◆
<b>17</b>	F05005-113	4	
<b>18</b>	F05010-69	4	
<b>19</b>	F05011-11	4	
<b>20</b>	S09915	1	

## 6.2 Système D'entraînement

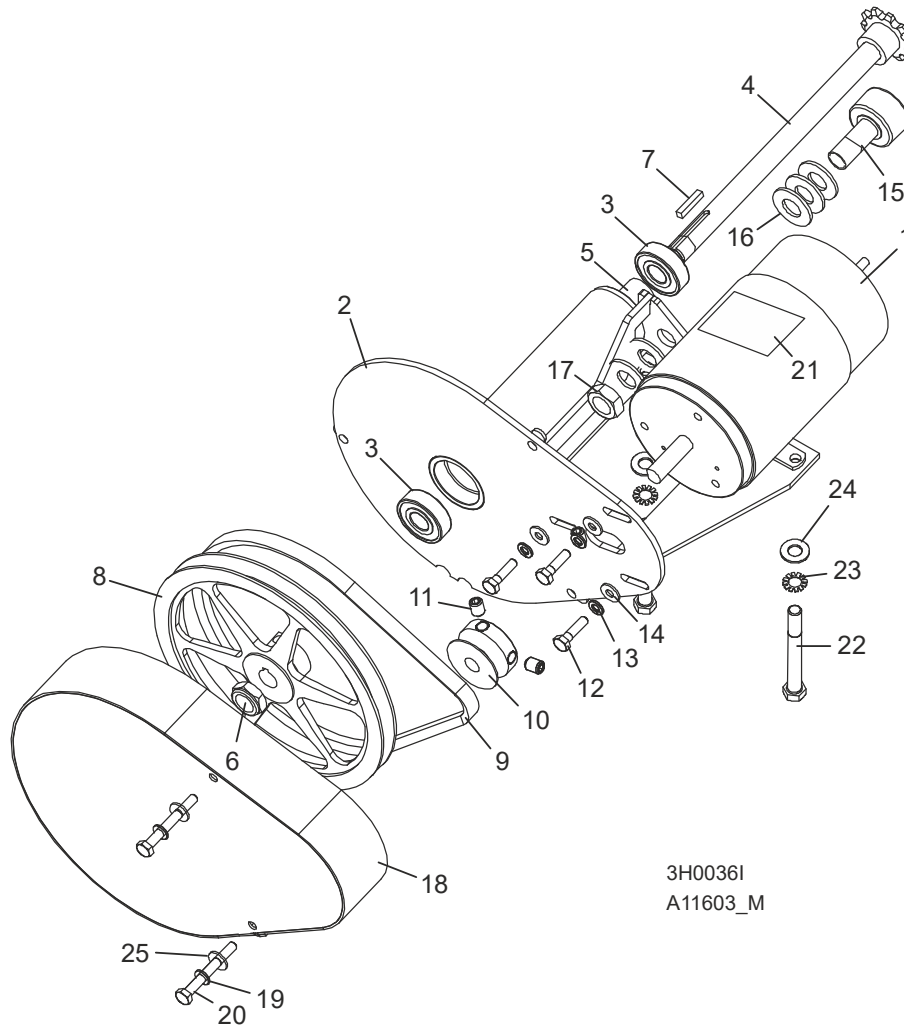

3H0036I  
A11603\_M

REF	PART #	QTY.
<b>1-22</b>	A11603	1
<b>1</b>	006747	1
<b>2</b>	066991	1
<b>3</b>	P06030-1	2
<b>4</b>	079798	1
<b>5</b>	079799	1
<b>6</b>	F05010-101	1
<b>7</b>	S31027	1
<b>8</b>	P04343	1
<b>9</b>	P04031	1
<b>10</b>	S09579	1

<b>11</b>	F05007-12	2
<b>12</b>	F05005-101	3
<b>13</b>	F05011-14	3
<b>14</b>	F05011-11	3
<b>15</b>	012797	1
<b>16</b>	F05011-5	6
<b>17</b>	F05010-11	1
<b>18</b>	W11613	1
<b>19</b>	F05011-14	2
<b>20</b>	F05005-7 <sup>1</sup>	2
<b>21</b>	024431	1
<b>22</b>	F05007-6	2

<b>23</b>	F05011-36	2
<b>24</b>	F05011-3	2
<b>25</b>	F05011-11 <sup>1</sup>	2

<sup>1</sup> ECN 35988:F05005-7 Replaced (2)  
F05005-32, Added (2) F05011-11



### 6.3 Chaîne D'entraînement Et Butoir

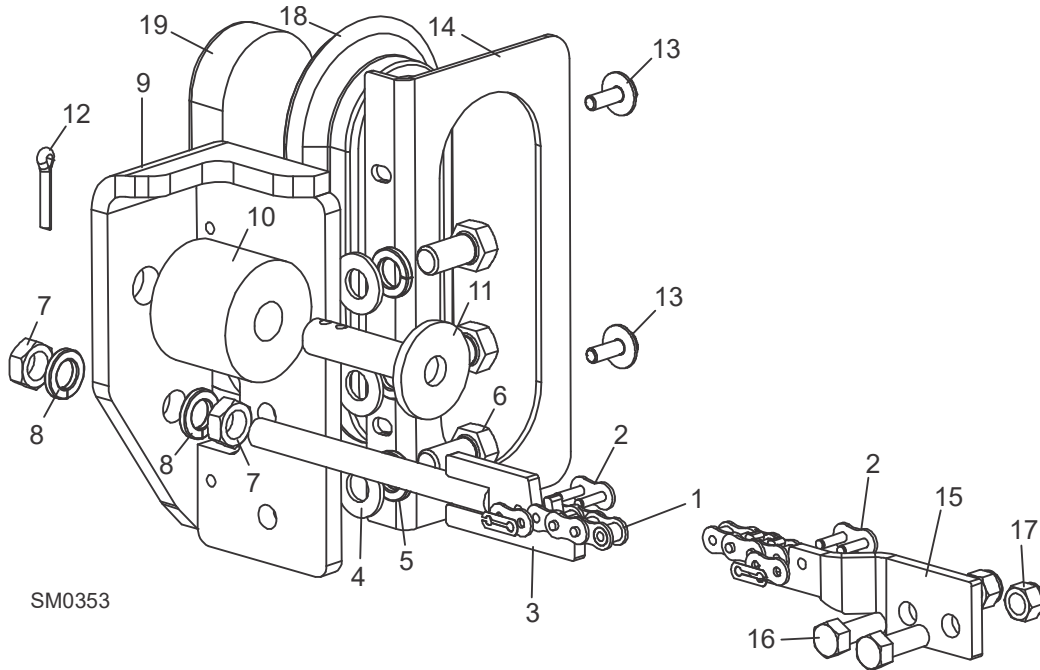

REF	PART #	QTY.
1	014744	1
	014745	1
2	P04200	2
3	015721	1
4	F05011-2	3
5	F05011-9	3
6	F05008-128	3

7	F05010-16	2
8	F05011-9	2
9	006686	1
10-12	K09630	2
10	P12165	1
11	W09293	1
12	F05012-21	1
13	F05005-134	2

14	057882	1
15	015008	1
16	F05007-7	2
17	F05010-10	2
18	006688	1
19	006391	1

## 6.4 Paliers De Rail Inférieur

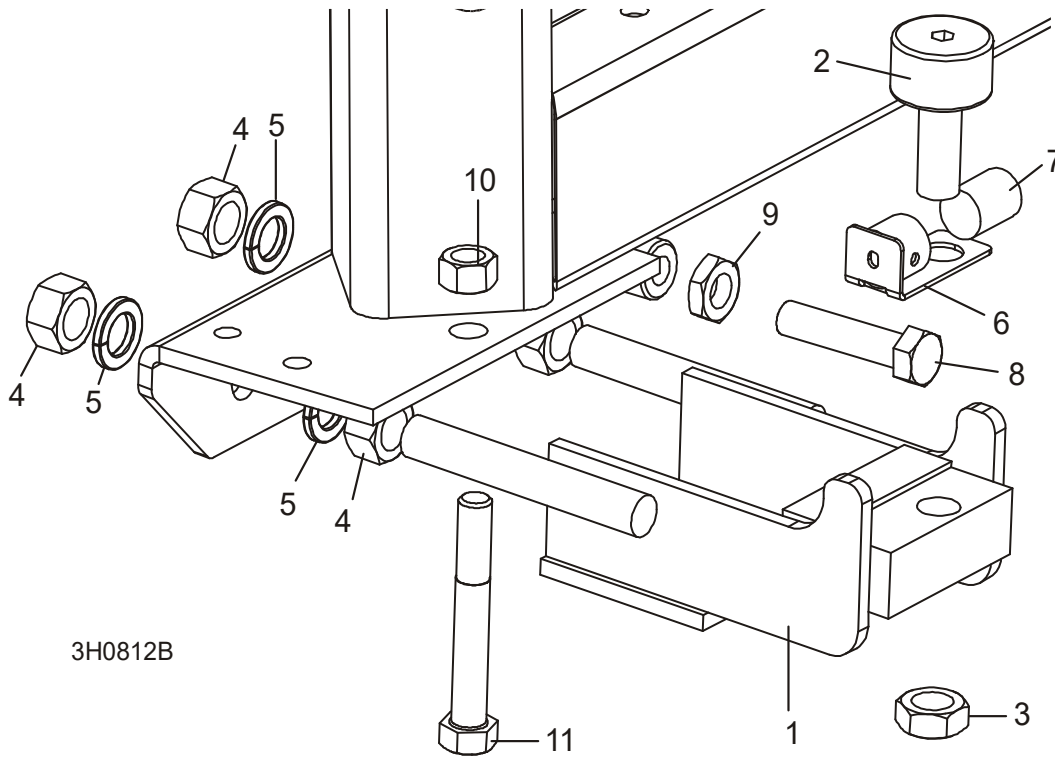

REF	PART #	QTY.
1-7	012995	2
1	----	1
2	012797	1
3	F05010-11	1
4	F05010-5	4
5	F05011-118	4
6	033374	1
7	033375	1
8	F05008-2	2
9	F05010-31	2
10	F05010-3	2
11	F05008-61	2

## PARTIE 7 BÂTI DE LA SCIE

### 7.1 Rails Avant Et Arrière Du Banc De Grume

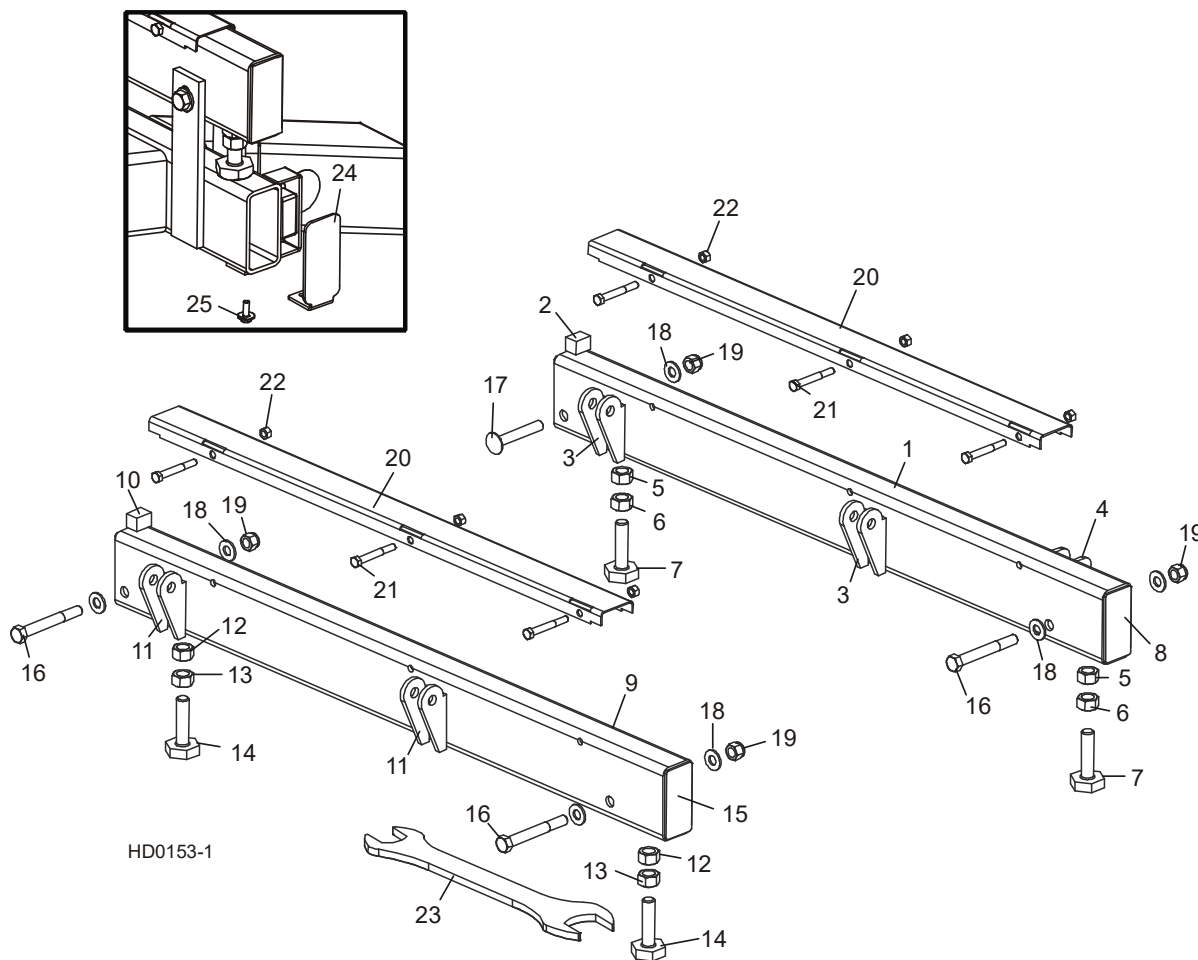

REF	PART #	QTY.
1-8	014467	1
1	-----	1
2	S09034	1
3	-----	4
4	-----	2
5	F05010-84	2
6	F05010-5	2
7	S13006	2
8	-----	2
9-15	014455	1
9	-----	1

10	S09034	1
11	-----	4
12	F05010-84	2
13	F05010-5	2
14	S13006	2
15	-----	2
16	F05008-78	3
17	F05008-94	1
18	F05011-2	7
19	F05010-8	4
20	016898	2
21	F05006-10	6

22	F05010-6	6
23	015970	1
24	038843	2
25	F05005-134	2

## 7.2 Rail Centre-avant Du Banc De Grume

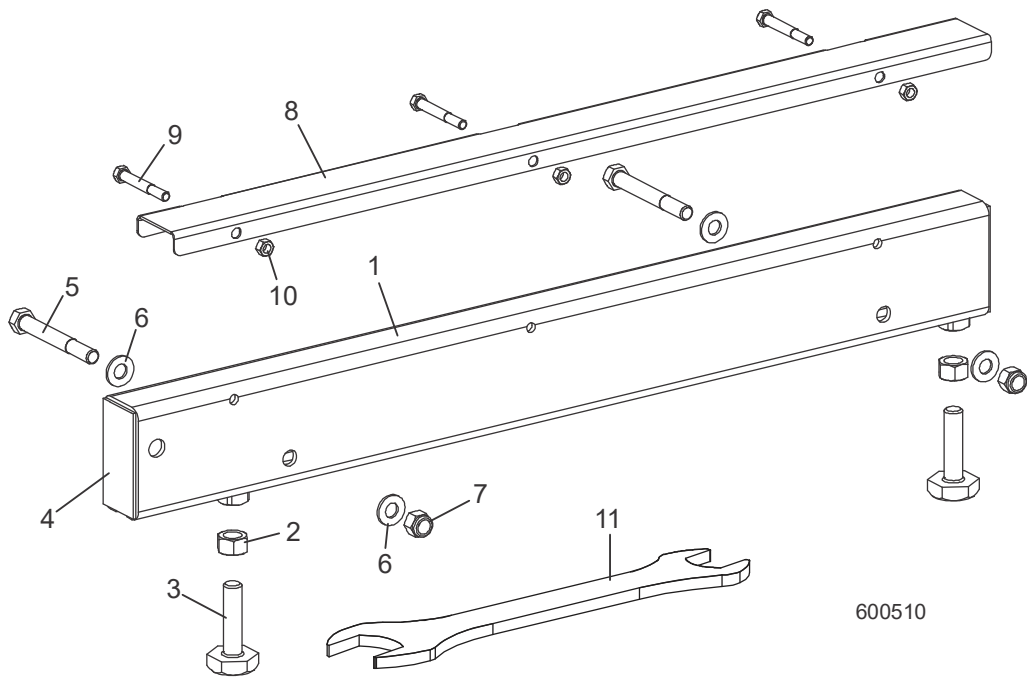

REF	PART #	QTY.
1-10	034549	1
1	034545	1
2	F05010-5	2
3	S13006	2
4	S04058	2
5	F05008-78	2
6	F05011-2	4
7	F05010-8	2
8-10	A09956	1
8	S09944	1
9	F05006-10	3
10	F05010-6	3
11	015970	1

### 7.3 Rail Centre-arrière Du Banc De Grume

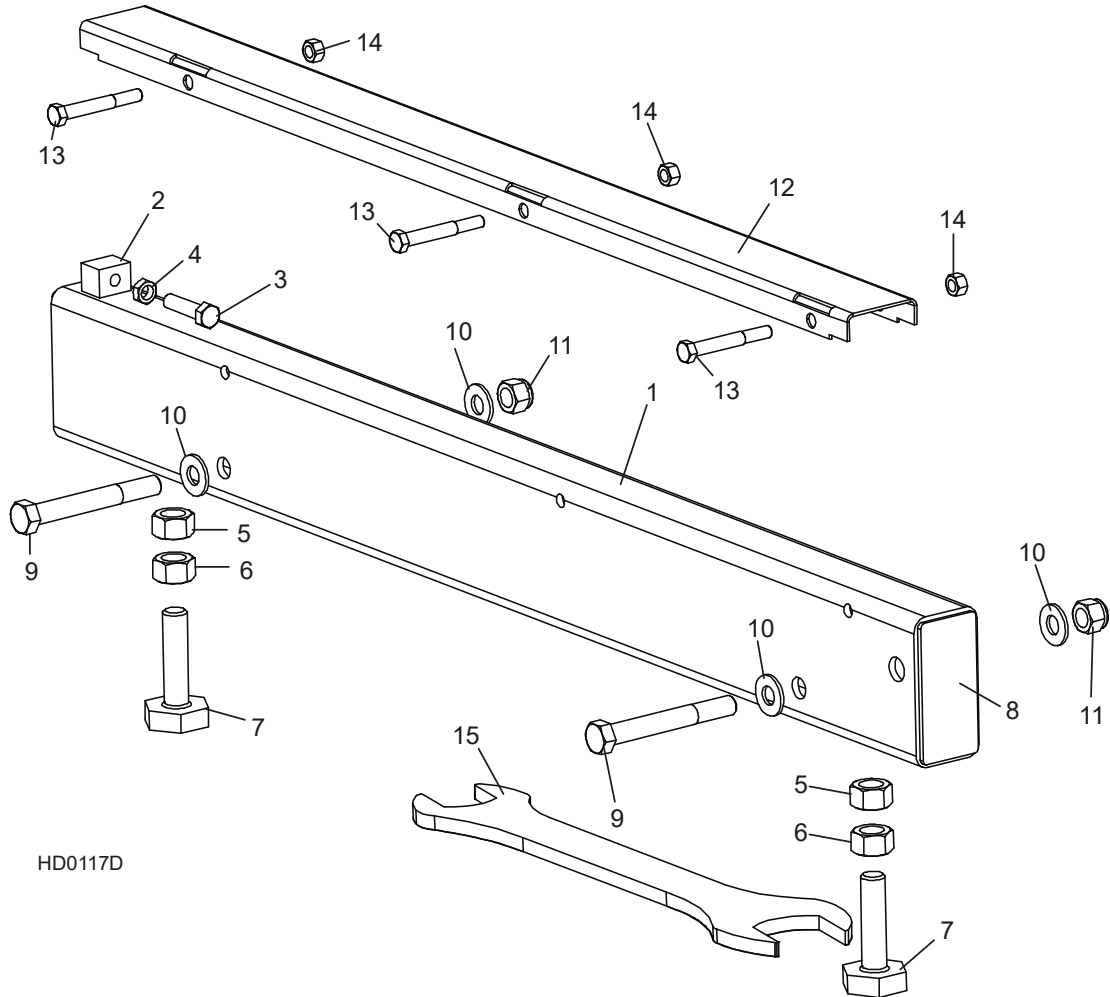

REF	PART #	QTY.
1-8	015757	1
1	014640	1
2	014639	1
3	F05007-17	1
4	F05010-29	1
5	F05010-187	2

6	F05010-5	2
7	S13006	2
8	S04058	1
9	F05008-78	2
10	F05011-2	4
11	F05010-8	2
12-14	A09956	1

12	----	1
13	F05006-10	3
14	F05010-6	3
15	015970	1

## 7.4 Appuis Fixes

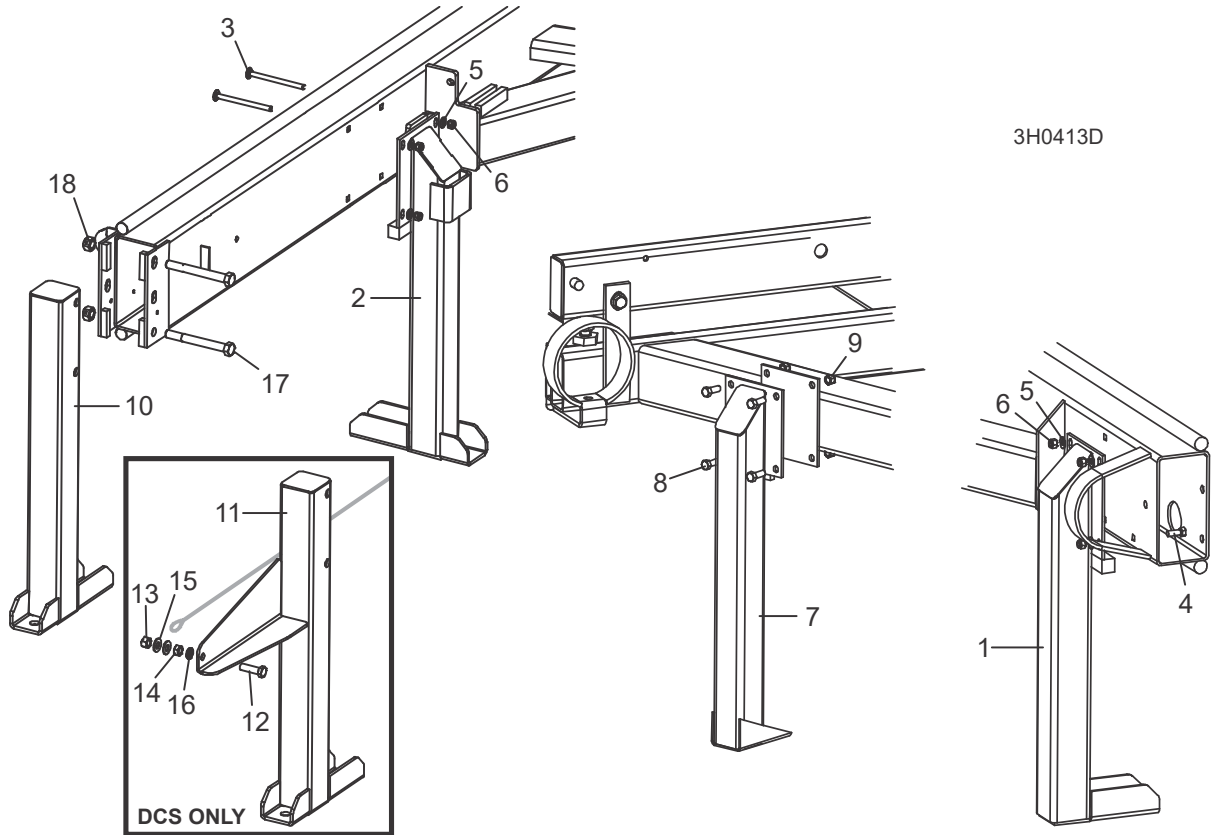

REF	PART #	QTY.
1	W09513	1/3
2	015091	1
3	F05007-113	8/12
4	F05007-2	4
5	F05011-3	8/16
6	F05010-10	8/16
7	W09515	2
8	F05007-2	8
9	F05010-10	8
10	W09517	1
11	F05009-11	2
12	F05010-4	2

### 7.10 Table D'éjecteur De Planches (Optionnel)

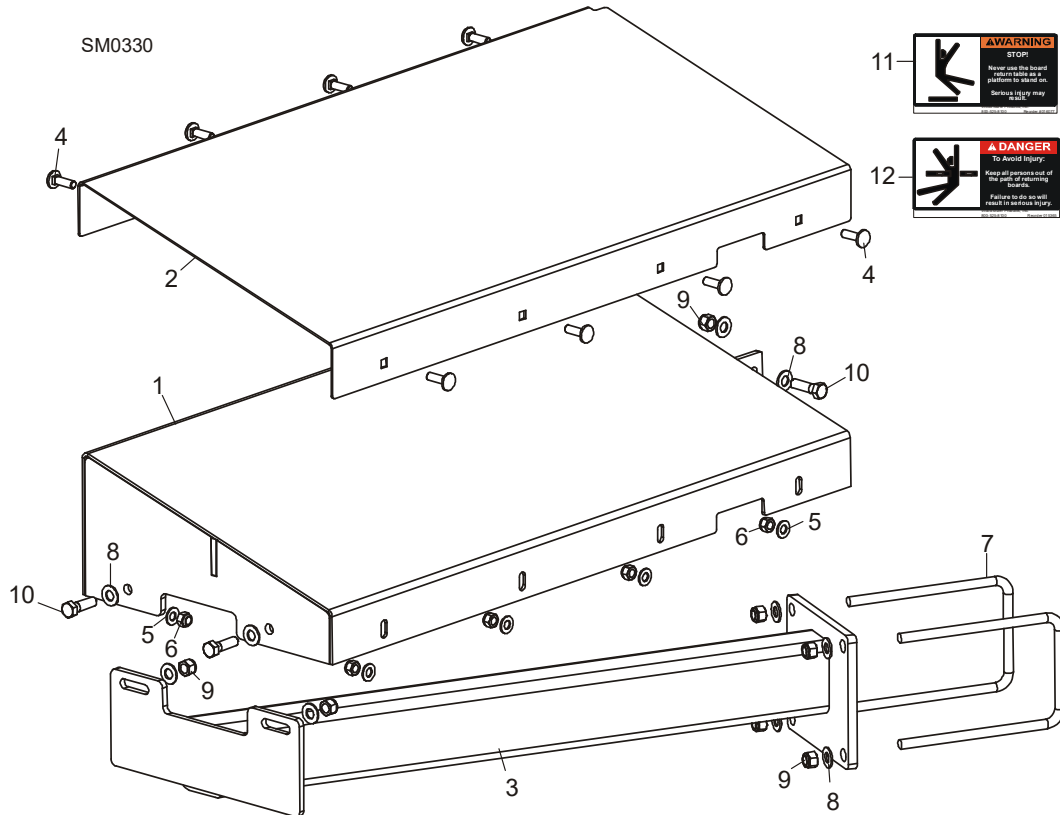

REF	PART #	QTY.
1-12	003264 <sup>1</sup>	1
	003270 <sup>2</sup>	1
1	055515	1
2	003259	1
3	055533 <sup>1</sup>	1
	038992 <sup>2</sup>	1
4	F05006-9	8
5	F05011-17	8
6	F05010-58	8
7	003207	2
8	F05011-3	10
9	F05010-10	7
10	F05007-123	3
11	016077-5	1
12	015365-5	1

<sup>1</sup> LT40

<sup>2</sup> LT30

## 7.5 Support De Grume Mobile

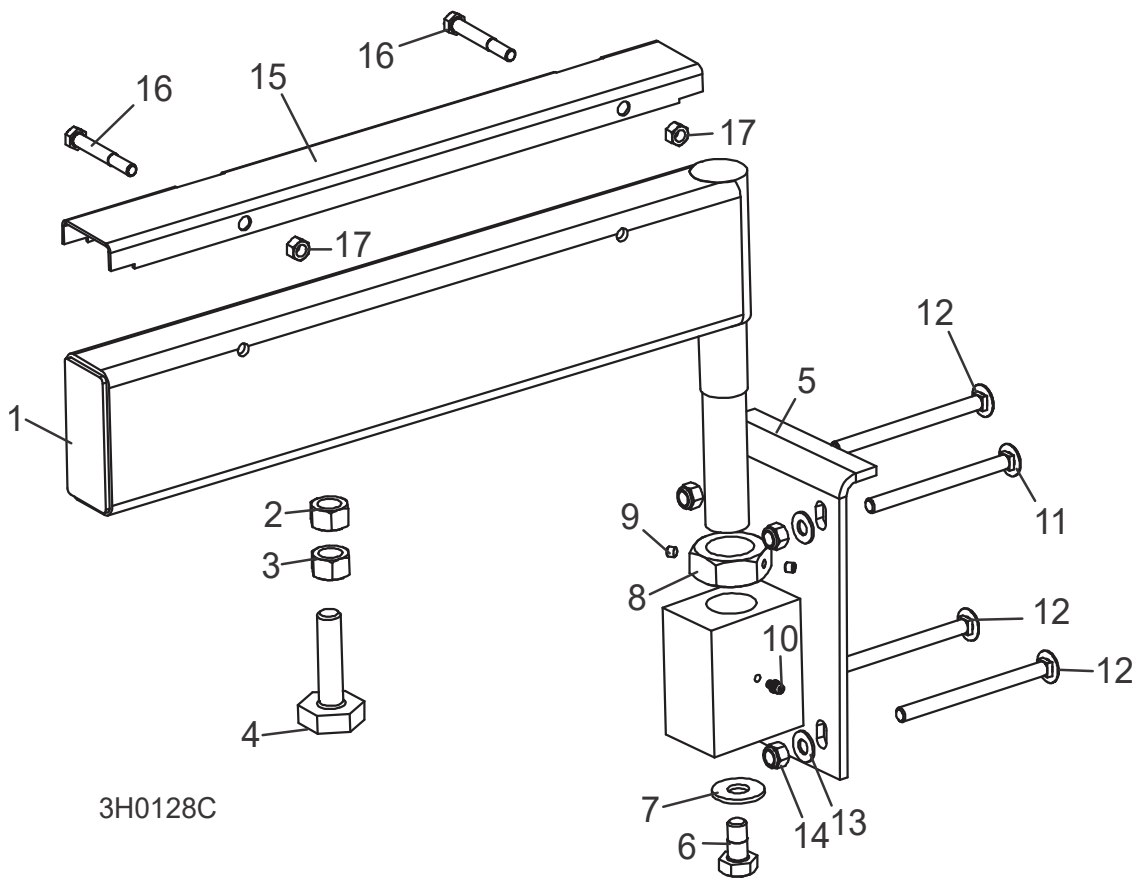

REF	PART #	QTY.
1-10	A13015 <sup>1</sup>	2
	012993 <sup>2</sup>	2
1-4	-----	1
	-----	1
2	F05010-84	2
3	F05010-5	2
4	S13006	2
5	W13090	1
6	F05008-50	1
7	F05011-52	1
8	S13016	1
9	F05005-42	2
10	P04107	1

11	F05007-114	2
12	F05007-113	6
13	F05011-3	8
14	F05010-10	8
15-17	017710 <sup>1</sup>	2
	015926 <sup>2</sup>	2
15	S13012 <sup>1</sup>	1
	012994 <sup>2</sup>	1
16	F05006-10	2
17	F05010-6	2

<sup>1</sup> LT40HD

<sup>2</sup> LT30HD



## 7.7 Chaîne De Sécurité

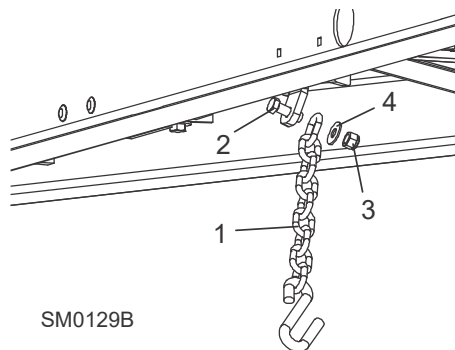

REF	PART #	QTY.
	107972	1
1	F05008-33	1
2	F05010-8	1
3	F05011-35	1

## 7.8 Attache De La Tête De Scie

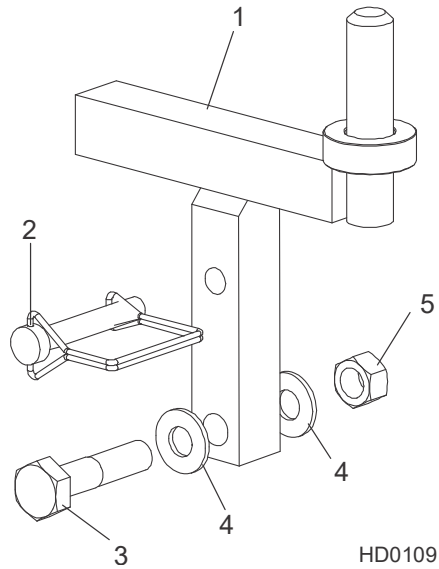

HD0109

REF	PART #	QTY.
1	014102	1
1	079510 (Wide)	1
2	014151	1
3	F05008-10	1
4	F05011-2	2
5	F05010-3	1

## 7.9 Étiquettes D'avertissement

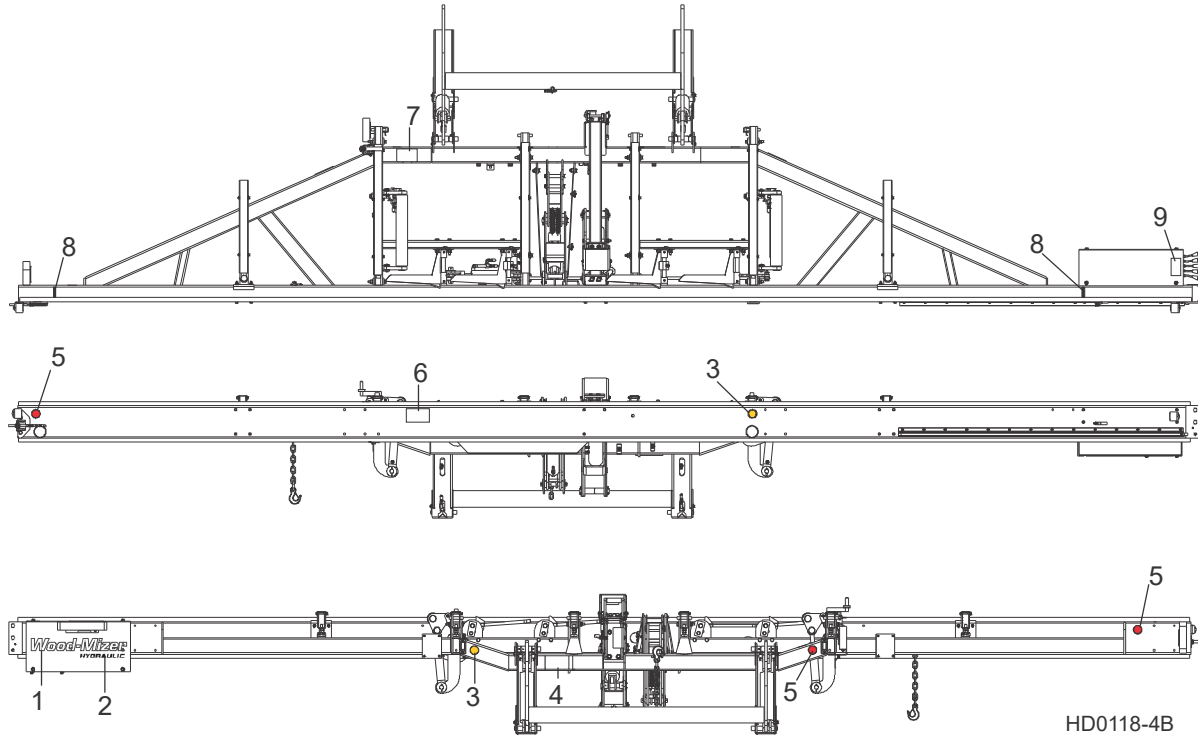

REF	PART #	QTY.
1	065034	1
2	065035	1
3	P07453	2
4	S09851	1
5	P07452	3
6	P10287	1
7	S12581	1
8	S12051	2
9	P12961	1

### 7.11 Table De Planches (Optionnel)

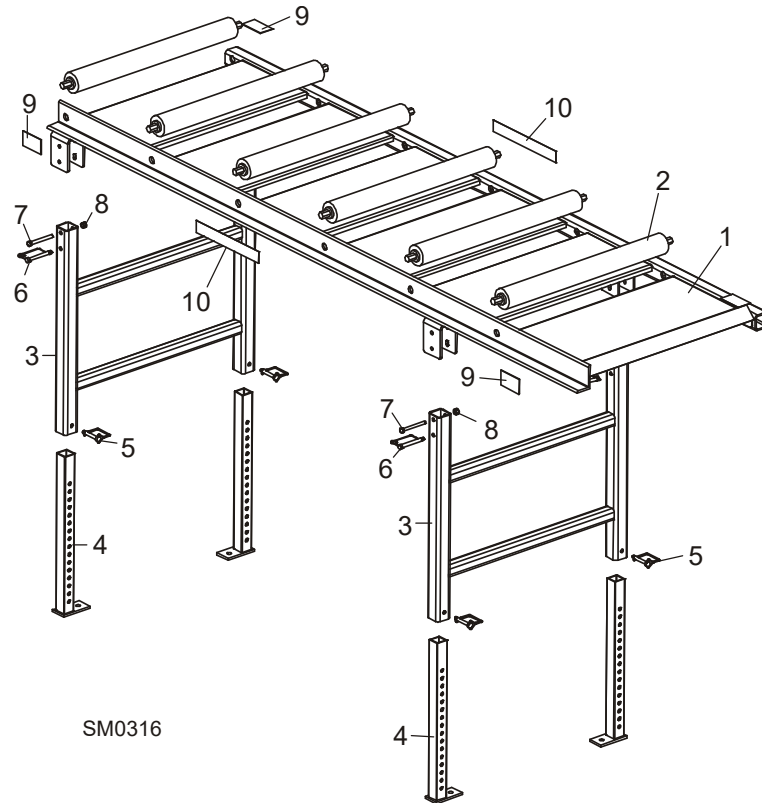

REF	PART #	QTY.
1-10	016652	1
1	016606	1
2	038167	6
3	016609	2
4	016651	4
5	014151	4
6	016677	4
7	F05007-135	4
8	F05010-10	4
9	S12641-5	4
10	016991	2

# PARTIE 8 SYSTEME HYDRAULIQUE

## 8.1 Boîte De Commande Des Hydrauliques

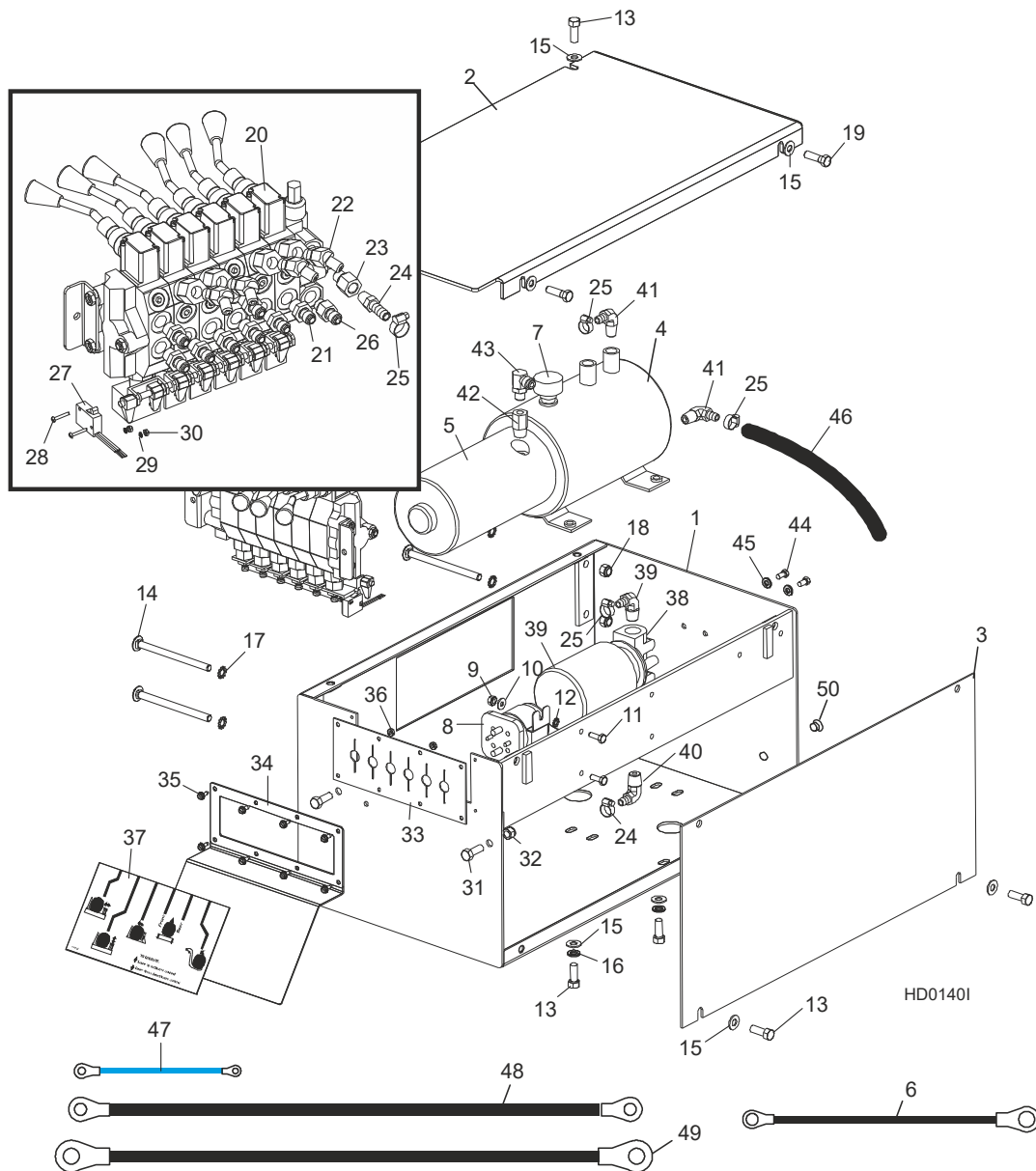

REF	PART #	QTY.
1	015027	1
2	015228	1
3	015227	1

4-7	061764	1
4	016199	1
5-6	052807	1
6	052806	1
7	P12817	1

8	016371	1
9	F05010-9	2
10	F05011-11	2
11	F05005-1	2

12	F05011-37	2
13	F05007-87	8
14	F05007-113	4
15	F05011-3	10
16	F05011-4	4
17	F05011-36	4
18	F05010-10	4
19	F05007-2	2
20	015260	1
21	P26284	8
22	015488	4
23	014686	1
24	014685	1
25	P12739	5
26	P26284	1
27	024198	1
28	F05004-13	2
29	F05011-21	2
30	F05010-43	2
31	F05007-7	2
32	F05010-10	2
33	015079	1
34	015078	1
35	F05015-7	8
36	F05010-14	2
37	015364	1
38-39	P22683	1
39	P20301	1
40	P12707	2
41	P12708	2
42	015490	1
43	P09142	1
44	F05005-15	2
45	F05011-14	2
46	R01892-1	A/R
47	036315	1
48	036310	1
49	036312	1
50	036778 <sup>1</sup>	2

<sup>1</sup> ECN:38166;

## 8.2 Plaque De Contact Hydraulique Et Bornes

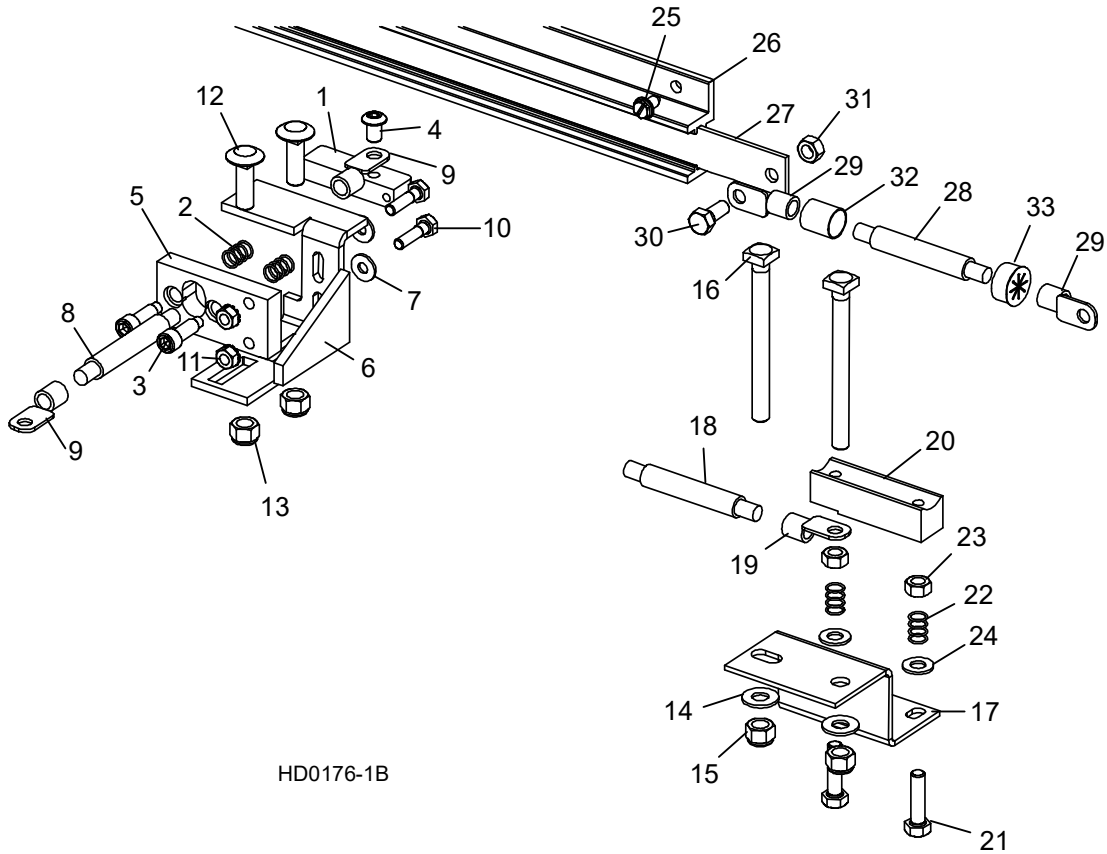

HD0176-1B

REF	PART #	QTY.
1-13	010103	1
1-4	007716	1
1	015253	1
2	P10077	2
3	F05006-143	2
4	F05006-20	1
5	S10072	1
6	015324	1
7	F05011-11	2
8	R01971	Ft
9	F05092-16	2
10	F05005-38	2
11	F05010-9	2
12	F05007-11	2

**8** **Système Hydraulique**  
*Plaque De Contact Hydraulique Et Bornes*

---

<b>13</b>	F05010-10	2
<b>14-24</b>	010104	1
<b>14</b>	F05011-3	2
<b>15</b>	F05010-10	2
<b>16</b>	F05007-175	2
<b>17</b>	016792	1
<b>18-19</b>	036306	1
<b>18</b>	-----	2.2 Ft
<b>19</b>	F05092-16	2
<b>20-23</b>	007717	1
<b>20</b>	015264	1
<b>21</b>	F05008-96	2
<b>22</b>	P10077	2
<b>23</b>	F05010-17	2
<b>24</b>	F05011-17	2
<b>25-33</b>	A11977	1
<b>25</b>	F05015-1	8
<b>26</b>	P11976	1
	A12043-N	1
<b>27</b>	-----	1
<b>28-29</b>	052161	
<b>28</b>	-----	Ft
<b>29</b>	F05092-16	2
<b>30</b>	F05006-45	1
<b>31</b>	F05010-86	1
<b>32</b>	R01950-5	.10 Ft
<b>33</b>	P04137	1



### 8.3 Chargeuse Hydraulique

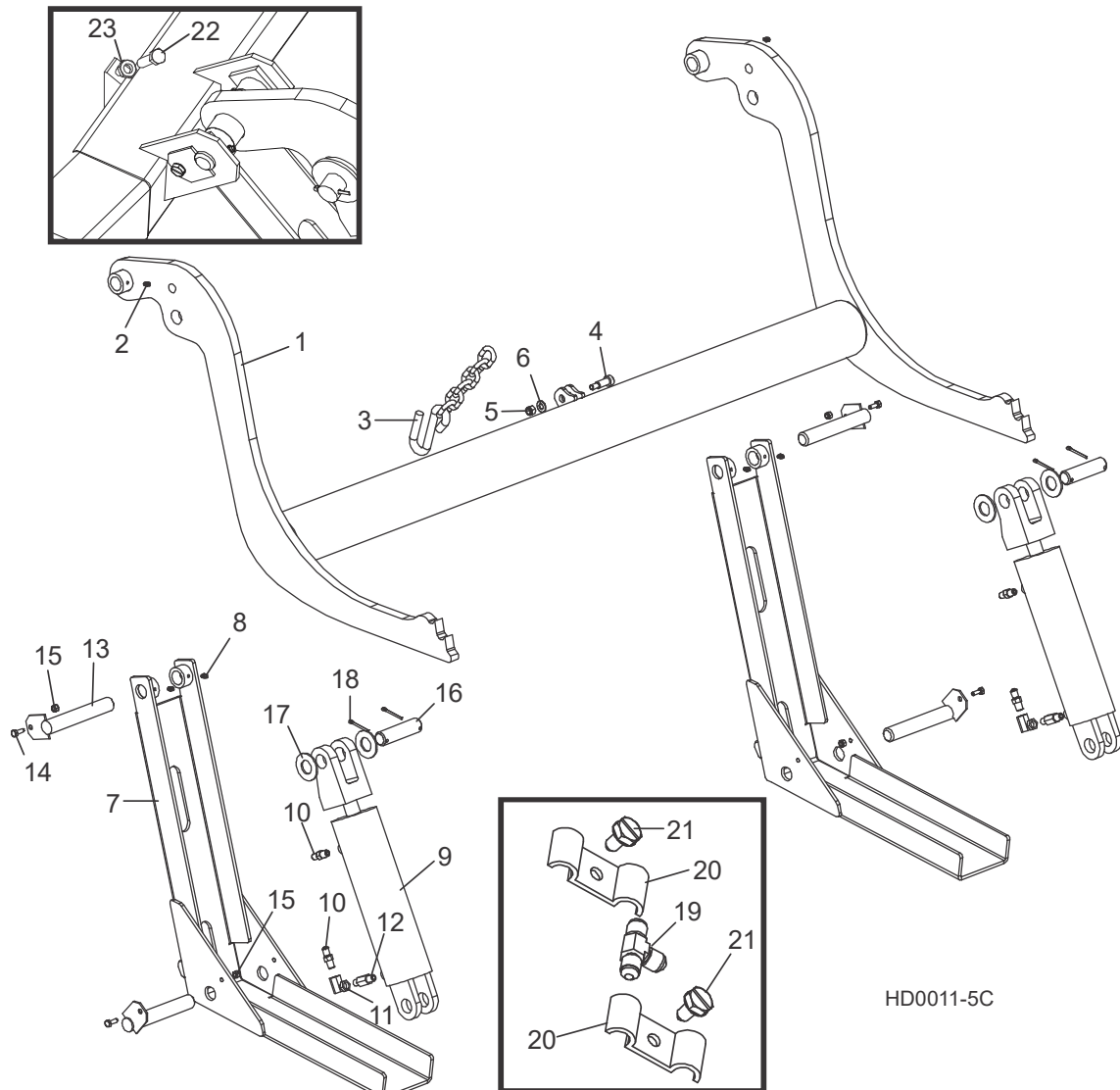

REF	PART #	QTY.	
	LTHDLA-30H	1	
	LTHDLA	1	
	036416	1	
1	110372	1	
2	P04107	2	
3	110472	1	
4	F05008-146	1	
5	F05010-10	1	

<b>6</b>	F05011-3	1	
<b>7</b>	W09444	2	
<b>8</b>	P04107	4	
	A09284	2	◆
<b>9</b>	P12847	1	
	P12956	1	
<b>10</b>	P09143	2	
<b>11</b>	P12199	1	
	015832	1	
<b>12</b>	015750	2	◆
	015832-255	1	
<b>13</b>	W09446	4	
<b>14</b>	F05005-1	4	
<b>15</b>	F05010-69	4	
<b>16</b>	S09251	2	
<b>17</b>	F05011-28	4	
<b>18</b>	F05012-23	4	
<b>19</b>	P09145	2	
<b>20</b>	S09245	6	
<b>21</b>	F05006-102	6	
<b>22</b>	F05008-116	2	
<b>23</b>	F05010-31	2	

## 8.4 Tourne-bille Hydraulique

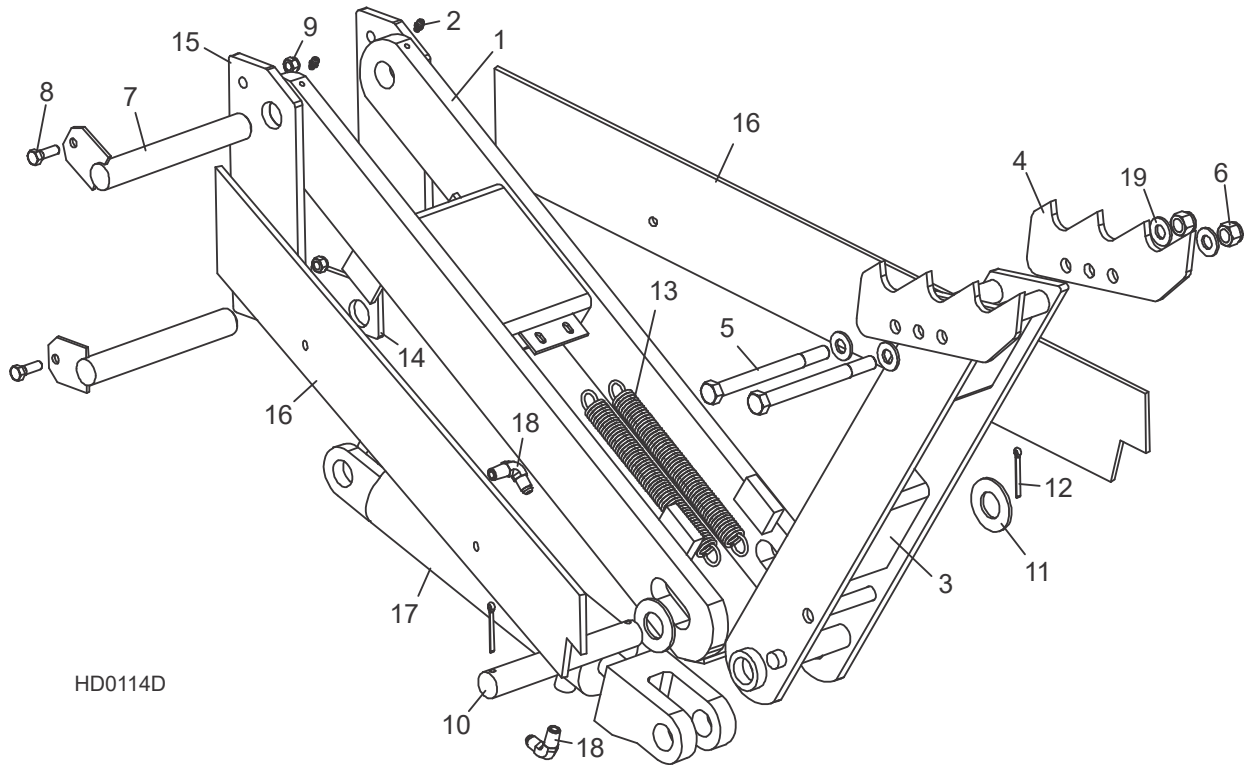

HD0114D

REF	PART #	QTY.
1	015231	1
2	P04107	2
3	015233	1
4	014675	2
5	F05008-28	2
6	F05010-8	2
7	015085	2
8	F05006-1	2
9	F05010-6	2
10	S09246	1
11	F05011-28	2
12	F05012-23	2
13	015718	2
14	S09155	1
15	S09109	2
16	S09605	2
17-18	A09286	1
17	-----	1

18	P09142	2
19	F05011-2	4

### 8.5 Cales Hydrauliques (Avant/Arrière)

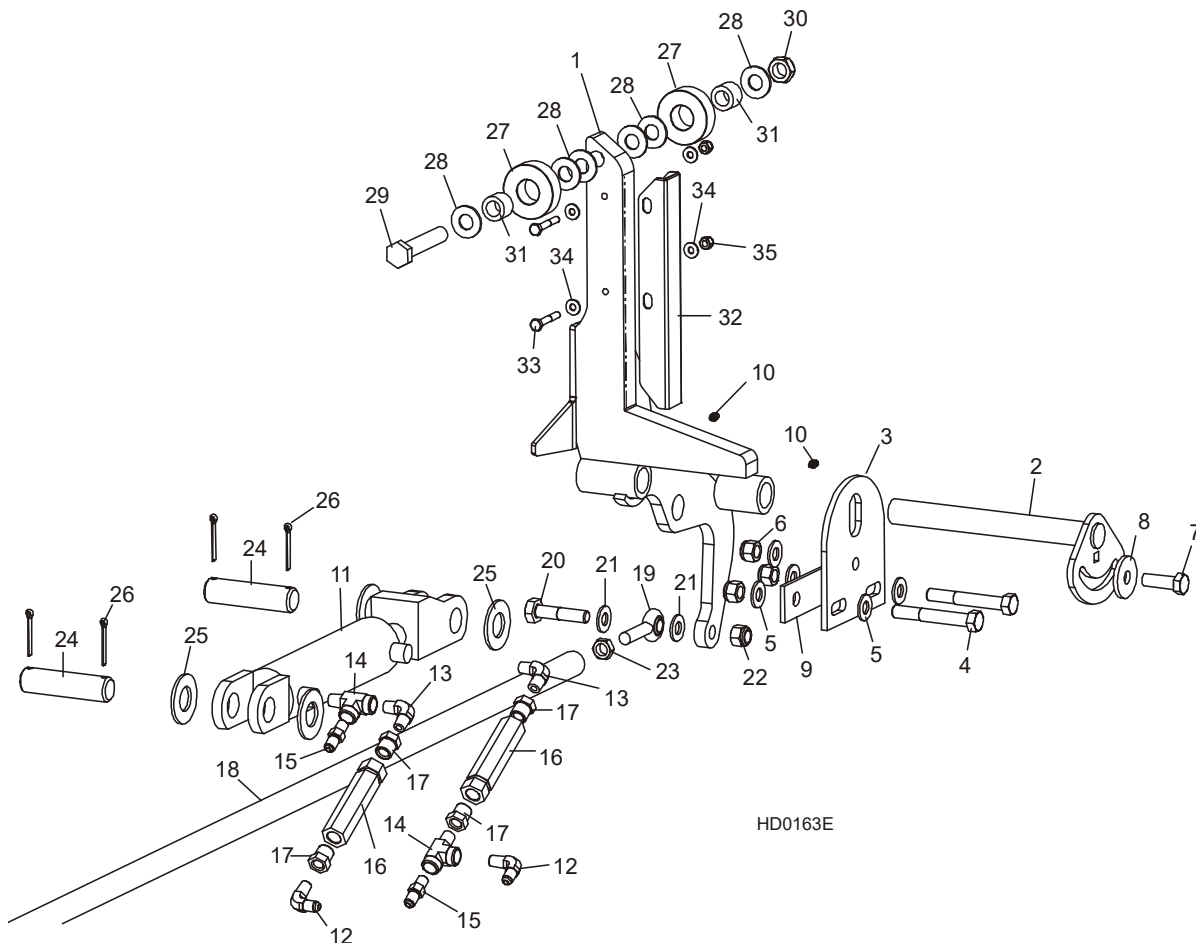

HD0163E

REF	PART #	QTY.
1	W12339	2
2-9	016559	2
2	016544	1
3	016555	1
4	F05008-61	2
5	F05011-2	2
6	F05010-8	3
7	F05008-33	1
8	F05011-2	1
9	016558	1
10	P04107	4
11-17	A09283	1
11	P12845	1
	P12954	1
12	P09142	2

13	P09140	2
14	P09141	2
15	P09143	2
16	015484	2
17	015490	4
18	015026	1
19	P09137	2
20	F05008-10	2
21	F05011-2	4
22	F05010-8	2
23	F05010-16	1
24	S09251	2
25	F05011-28	4
26	F05012-23	4
27-31	016562	2
27	016561	2

28	F05011-5 <sup>1</sup>	6
29	F05009-118	1
30	F05010-96	1
31	016560	2
	F05008-94	1
	016562-526	1
32-35	016798	1
32	016722	4
33	F05005-4	8
34	F05011-11	16
	F05011-5 <sup>1</sup>	4
35	F05010-69	8
	016798-1005	1

<sup>1</sup> Additional 5/8" SAE Flat Washer F05011-5 may be required on each side of side support to provide clearance for optional stainless steel side support guards. Extra washers are included in the stainless steel guard retrofit kit (016798).

## 8.6 Cales Hydrauliques (Centre - Optionnel)

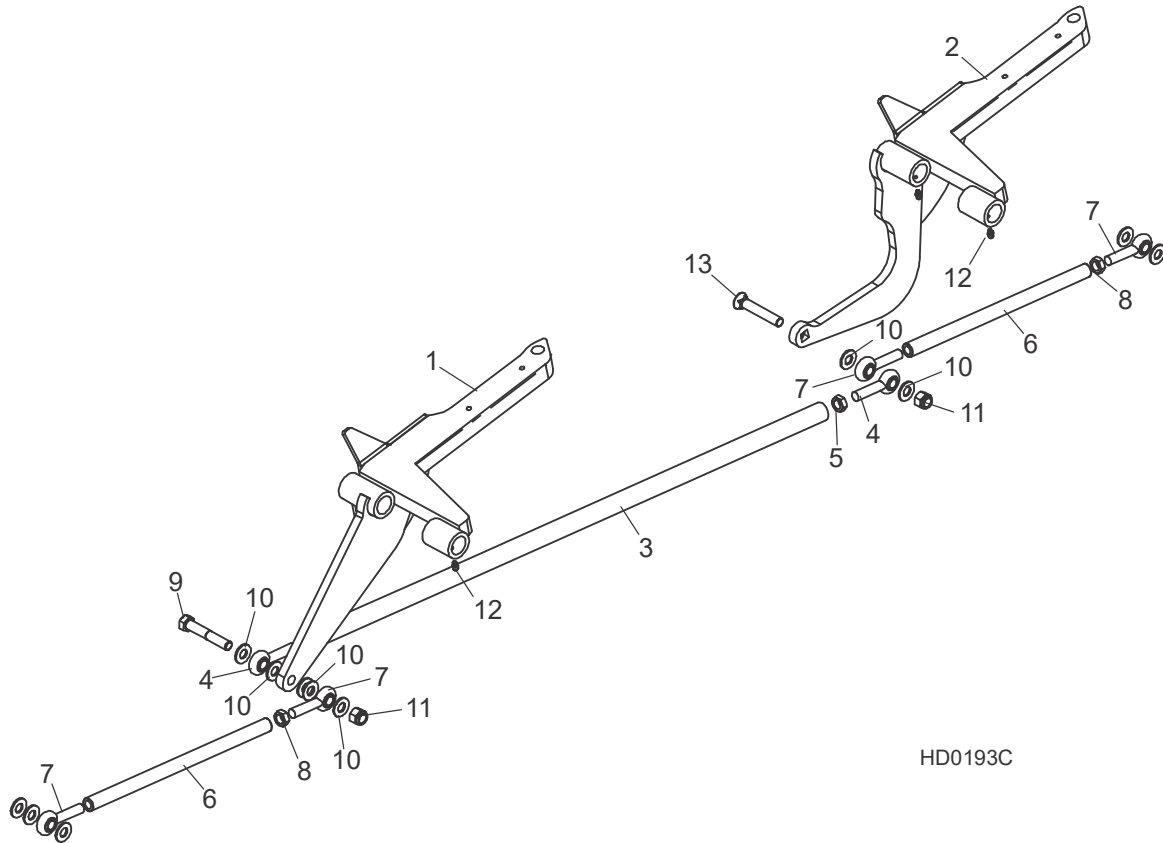

HD0193C

REF	PART #	QTY.
	HSS-A	1
1	048436	1
2	048438	1
3	048537	1
4	P09137	2
5	F05010-16	1
	048247	2
6	048246	1
7	P09137	2
8	F05010-16	1
9	F05008-23	1
10	F05011-2	12
11	F05010-8	2
12	P04107	4
13	F05008-158	1

## 8.7 Serre Hydraulique

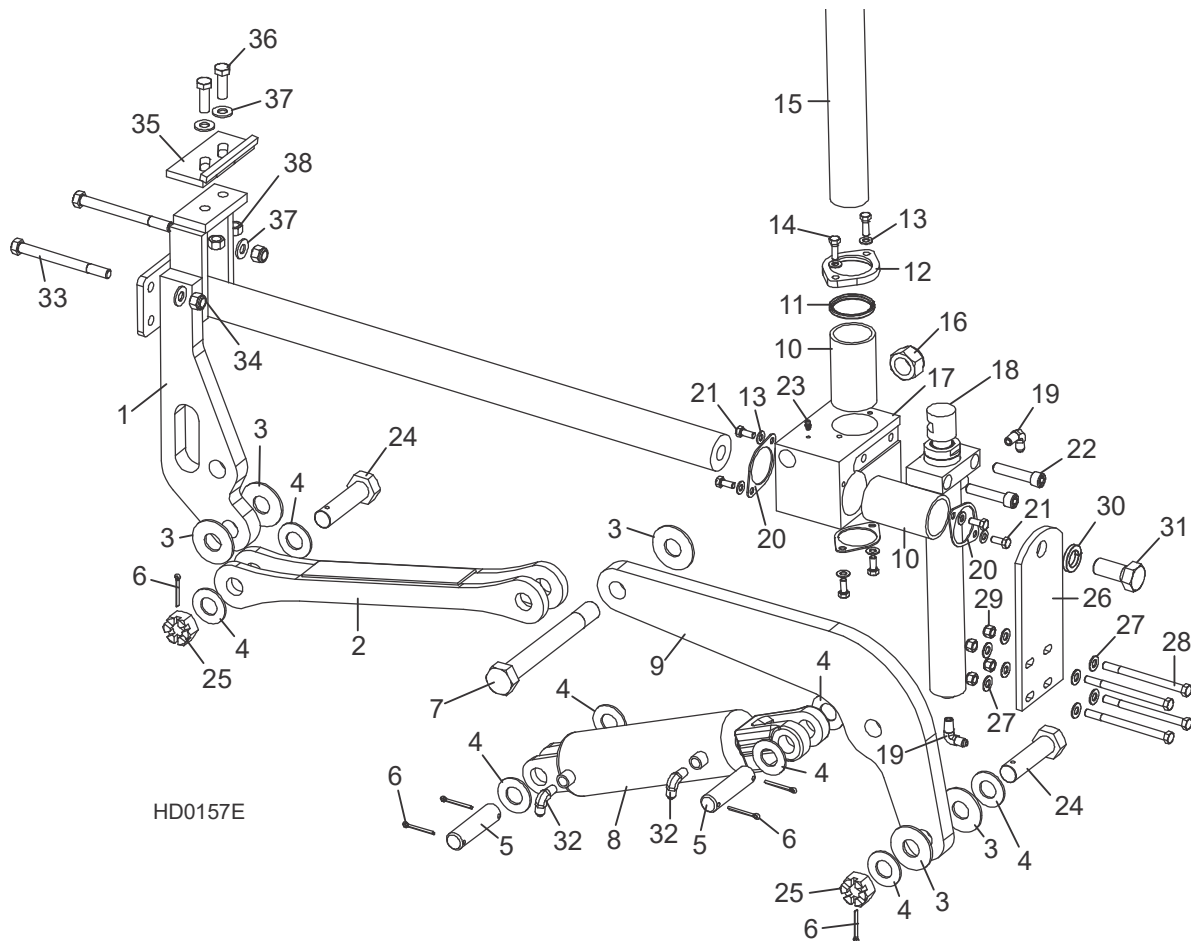

HD0157E

REF	PART #	QTY.
1-38	017264	1
1	017265	1
2	017267	1
3	015057	5
4	F05011-28	8
5	S09251	2
6	F05012-23	6
7	015049	1
8	017275	1
9	017274	1
10	015088	2
11-12	017271	1
11	017273	1
12	017272	1

13	F05011-17	8
14	F05006-1	2
15	015043	1
16	F05010-118	2
17	017270	1
18	015050	1
19	P09142	2
20	017242	3
21	F05006-5	6
22	F05008-39	2
23	P04107	1
24	015072	2
25	F05010-163	2
26	015068	1
27	F05011-3	8

28	F05007-5	4
29	F05010-10	4
30	F05011-46	1
31	F05014-2	1
32	015491	2
33	F05008-28	2
34	F05010-8	2
35-38	K09485	1
35	W09404	1
36	F05008-33	2
37	F05011-2	2
38	F05010-3	2

## 8.8 Niveleur De Grume Hydraulique

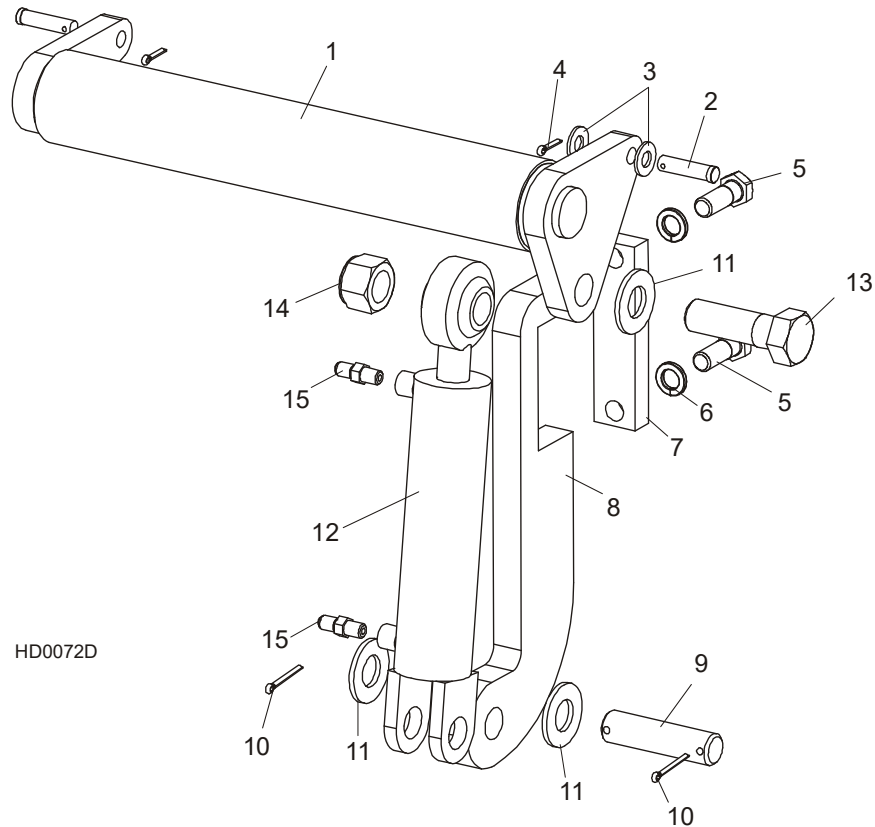

REF	PART #	QTY.
1	074842	2
2	F05012-82	4
3	F05011-2	4
4	F05012-3	4
5	F05009-33	4
6	F05011-27	4
7	S13023	2
8	S13022	2
9	S09251	2
10	F05012-23	4
11	F05011-28	6
12	014482	2
13	F05009-51	2
14	F05010-109	2
15	P09143	4