

Scierie Wood-Mizer®

Manuel de pièces

LT40 Super

rev. J7.19



La sûreté est notre souci principal! Lisez et comprenez toutes les informations et instructions de sûreté avant d'actionner, installer ou mettre en opération cette machine.

#534-5

California

Proposition 65 Warning



WARNING: Breathing gas/diesel engine exhaust exposes you to chemicals known to the State of California to cause cancer and birth defects or other reproductive harm.

Always start and operate the engine in a well-ventilated area.
If in an enclosed area, vent the exhaust to the outside.
Do not modify or tamper with the exhaust system.
Do not idle the engine except as necessary.

For more information go to www.P65warnings.ca.gov.



WARNING: Drilling, sawing, sanding or machining wood products can expose you to wood dust, a substance known to the State of California to cause cancer. Avoid inhaling wood dust or use a dust mask or other safeguards for personal protection.

For more information go to www.P65Warnings.ca.gov/wood.

©2019

Printed in the United States of America, all rights reserved. No part of this manual may be reproduced in any form by any photographic, electronic, mechanical or other means or used in any information storage and retrieval system without written permission from

Wood-Mizer
8180 West 10th Street
Indianapolis, Indiana 46214

PARTIE 1	SYSTÈMES DE GUIDAGE DE LAME	1-1
1.1	Guidage De Lame, Côté Poulie Folle.....	1-1
1.2	Guidage De Lame, Côté Entraînement.....	1-2
1.3	Système D'entraînement De Bras De Guidage.....	1-2
1.4	Bras de Guidage de Lame.....	1-2
PARTIE 2	POULIES ET TENDEUR	2-1
2.1	Système D'entraînement De Lame	2-1
2.2	Poulie Folle.....	2-2
2.3	Tendeur Hydraulique De Lame	2-3
PARTIE 3	TÊTE DE SCIE	3-1
3.1	Vis Anti-Vibration.....	3-1
3.2	Valve Du Contrôle De Lubrification.....	3-2
3.3	Système D'embrayage (D47/D51).....	3-3
3.4	Système D'embrayage (E25)	3-4
3.5	Fixation d'embrayage	3-5
3.6	Système De Freinage.....	3-6
3.7	Éjecteur De Planches.....	3-7
3.8	Système De Lubrification (Gas).....	3-9
3.9	Système De Lubrification (Diesel & Electric)	3-10
3.10	Étiquettes D'avertissement	3-11
3.11	Couvercles De Carters De Lame	3-12
3.12	Couvercles De Carters De Courroies	3-13
3.13	Chute À Bran De Scie	3-14
3.14	Boîte De Filage De L'écorceuse Et Obturateurs.....	3-15
PARTIE 4	SYSTÈME DE COMMANDE ET BATTERIE	4-1
4.1	Système De Commande	4-1
4.2	Commutateurs.....	4-3
4.3	Disjoncteurs	4-4
4.4	Panneau De Commande	4-5
4.5	Boîte De Batterie	4-7
PARTIE 5	SYSTÈME DE MONTÉE	5-1
5.1	Fixation De La Tête De Sciage	5-1
5.2	Indicateur De Hauteur Et Règles De Débitage.....	5-2
5.3	Chaînes Et Pignons De Montée.....	5-3
5.4	Moteur De Montée	5-4
5.5	Système D'entraînement De Montée	5-5

PARTIE 6	SYSTÈME D'ENTRAÎNEMENT ET PALIERS	6-1
6.1	Paliers de Rail Supérieur et Grattoirs	6-1
6.2	Système D'entraînement	6-3
6.3	Chaîne D'entraînement Et Butoir	6-5
6.4	Paliers De Rail Inférieur	6-6
PARTIE 7	BÂTI DE LA SCIE	7-1
7.1	Rails Avant Et Arrière Du Banc De Grume	7-1
7.2	Rail Centre-avant Du Banc De Grume	7-2
7.3	Rail Centre-arrière Du Banc De Grume	7-3
7.4	Appuis Fixes	7-4
7.5	Table D'éjecteur De Planches	7-5
7.6	Support De Grume Mobile	7-6
7.7	Cales À Billes (Non Hydrauliques)	7-7
7.8	Chaîne De Sécurité	7-8
7.9	Étiquettes D'avertissement	7-9
7.10	Serre-bille	7-10
7.11	Rampes De Chargement	7-11
7.12	Table De Planches (Optionnel)	7-12
PARTIE 8	CHARGEUSE & TOURNE-BILLE HYDRAULIQUE (OPTIONNEL)	8-1
8.1	Boîte De Commande Des Hydrauliques	8-1
8.2	Plaque De Contact Hydraulique Et Bornes	8-3
8.3	Chargeuse Hydraulique (Optionnel)	8-4
8.4	Tourne-bille Hydraulique (Optionnel)	8-6
8.5	Cales Hydrauliques (Optionnel)	8-7
8.6	Chargeuse & tourne-bille hydraulique pièces	8-8

PARTIE 1 SYSTÈMES DE GUIDAGE DE LAME

1.1 Guidage De Lame, Côté Poulie Folle

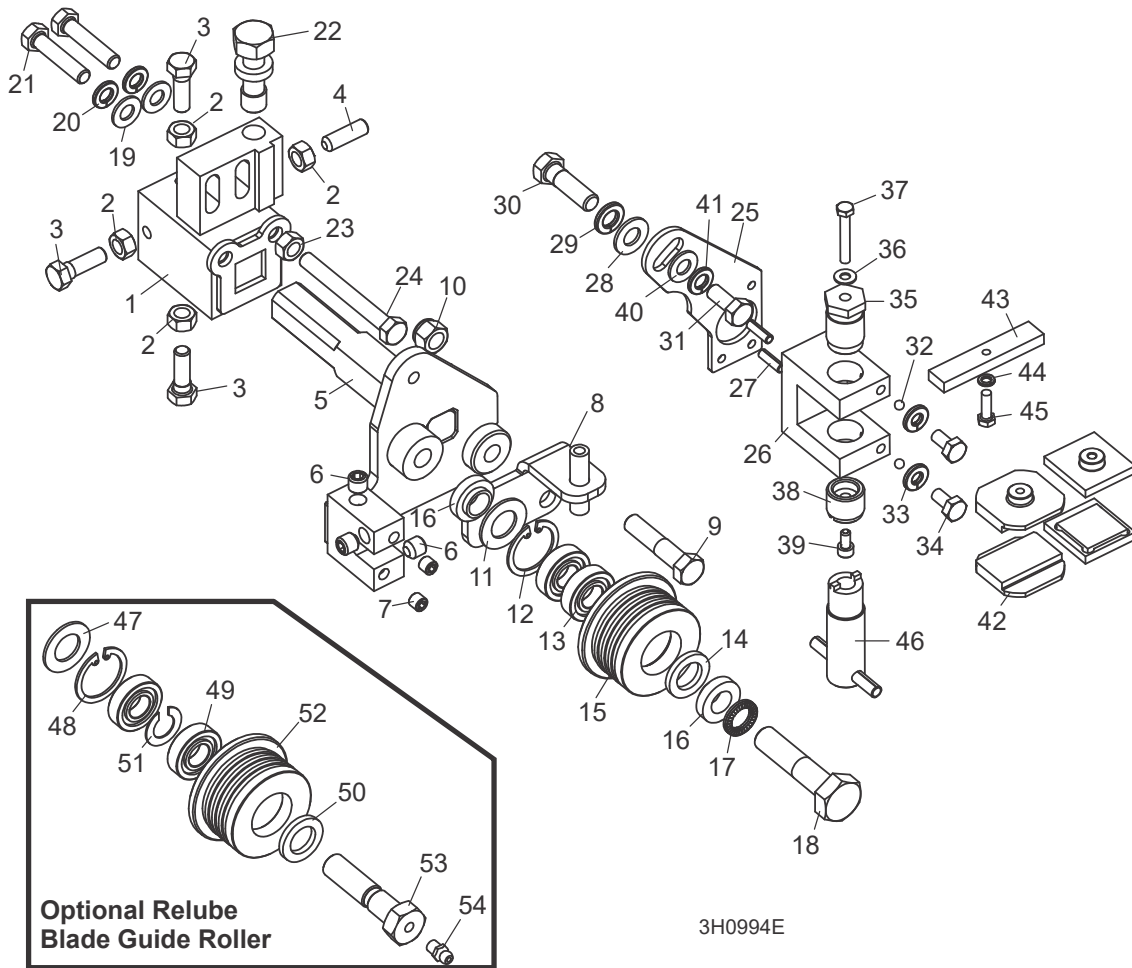

REF	PART #	QTY.
1-24	003992	1
1-4	003920	1
1	-----	1
2	F05010-17	4
3	F05006-88	3
4	F05006-122	1
5	003924	1
6	P30127	3
7	007734	2

8	006322	1
9	F05007-78	1
10	F05010-10	1
11-15	A04925 ¹	1
	014299 ²	1
11-14	K07079	1
11	P04252	1
12	F04254-1	1
13	-----	2
14	P06455	1

15	S04250	1
	014298	1
16	S04253	2
17	F05011-125	1
18	F05008-10	1
19	F05011-17	2
20	F05011-13	2
21	F05006-76	2
22	035656	1
23	F05010-17	1
24	F05006-136	1

1 Systèmes De Guidage De Lame

Guidage De Lame, Côté Poulie Folle

25-46	006325	1
25-41	003928 ³	1
25	003915	1
26	003909	1
27	F05012-22	2
28	F05011-3	1
29	F05011-4	1
30	F05007-123	1
31	F05006-102	1
32	003914	2
33	F05011-14	2
34	F05005-15	2
35	003994	1
36	042867	1
37	F05004-240	1
38	044057	1
39	F05004-200	1
40	F05011-17	1
41	F05011-13	1
42	052355 ⁴	2
	052309 ⁵	2
	036347 ⁶	2
43	035799	1
44	F05011-20	1
45	F05004-152	1
46	044064	1
	035248	1
	<i>(Voir Partie 1.2)</i>	
47-52	016568 ⁷	1
	057405 ⁸	1
47-51	057407	1
47	P04252	1
48	F04254-1	1
49	-----	2
50	P06455	1
51	035411	1
52	035426	1
	057402	1
53	036161	1
54	P05060	1

³ Optionelle.

⁴ Std. 1 1/4" lame.

⁵ Optionelle 1 1/2" lame.

⁶ Optionelle 1 1/4" lame.

⁷ Optionelle 1 1/4" ou 1 1/2" lame.

⁸ Optionelle 1 1/2" lame.

¹ Std. 1 1/4" ou 1 1/2" lame.

² Optionelle 1 1/2" lame.

1.2 Guidage De Lame, Côté Entraînement

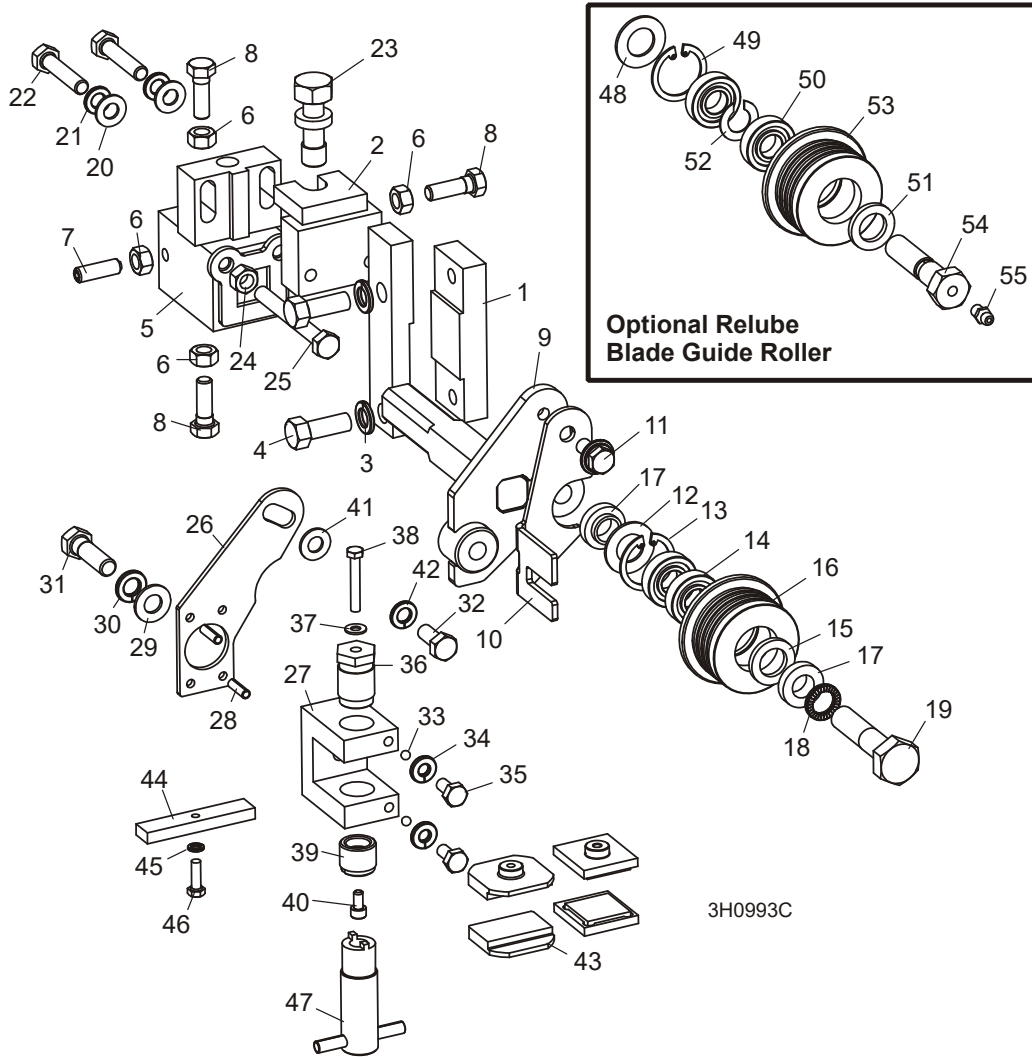

REF	PART #	QTY.
1	016548	1
2	003964	1
3	F05011-4	2
4	F05007-7	2
1-25	003905	1
5-8	003910	1
5	-----	1
6	F05010-17	4
7	F05006-122	1
8	F05006-88	3
9	003913	1

10	003916	1
11	F05006-101	1
12-16	A04925 ¹	1
	014299 ²	1
12-15	K07079	1
12	P04252	1
13	F04254-1	1
14	-----	2
15	P06455	1
16	----- ¹	1
	----- ²	1

17	S04253	2
18	F05011-125	1
19	F05008-10	1
20	F05011-17	2
21	F05011-13	2
22	F05006-76	2
23	035656	1
24	F05010-17	1
25	F05006-16	1
26-45	006325 ³	1
26-40	003927	1
26	003915	1

1

Systèmes De Guidage De Lame

Guidage De Lame, Côté Entraînement

27	003909	1
28	F05012-22	2
29	F05011-3	1
30	F05011-4	1
31	F05007-123	1
32	F05006-101	1
33	003914	2
34	F05011-14	2
35	F05005-15	2
36	003994	1
37	042867	1
38	F05004-240	1
39	044057	1
40	F05004-200	1
41	052355 ⁴	2
	052309 ⁵	2
	036347 ⁶	2
42	035799	1
43	F05011-20	1
44	F05004-152	1
45	044064	1
	(Voir Partie 1.1)	
46-51	016568 ⁷	1
	057405 ⁸	1
46-50	057407	1
46	P04252	1
47	F04254-1	1
48	-----	2
49	P06455	1

50	035411	1
51	-----7	1
	-----8	1
52	036161	1
53	P05060	1

- 1 Std. 1 1/4" ou 1 1/2" lame.
- 2 Optionelle 1 1/2" lame.
- 3 Optionelle.
- 4 Std. 1 1/4" lame.
- 5 Optionelle 1 1/2" lame.
- 6 Optionelle 1 1/4" lame.
- 7 Optionelle 1 1/4" ou 1 1/2" lame.
- 8 Optionelle 1 1/2" lame.

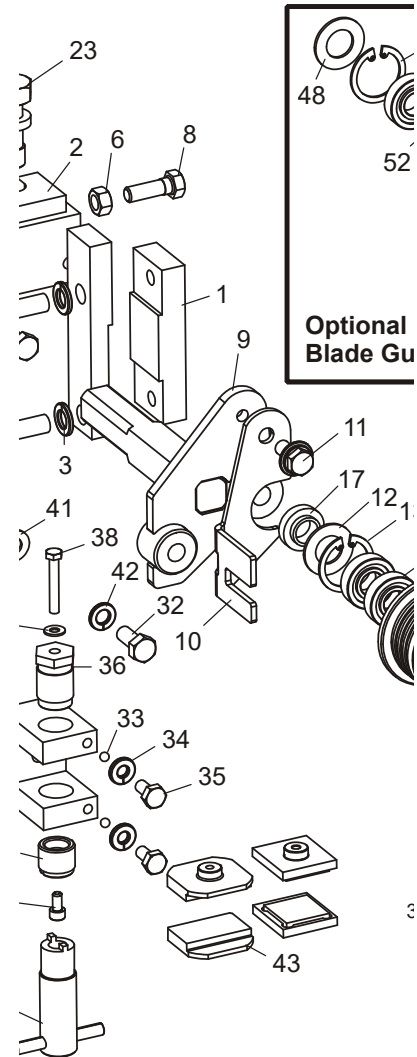

REF	DESCRIPTION (◆ Indicates Parts Available In Assemblies Only)	PART #	QTY.
1	BLOCK, BOLT ON BLADE GUIDE MOUNT	016548	1
2	BRACKET WELDMENT, INNER BLADE GUIDE MOUNT	003964	1
3	WASHER, 3/8" SPLIT LOCK	F05011-4	2
4	BOLT, 3/8-16 X 1" HEX HEAD	F05007-7	2
	GUIDE ASSEMBLY, DRIVE SIDE BLADE ROLLER	003905	1
	Block Assembly, Blade Guide Mount	003910	1
5	Block Weldment, Blade Guide Mount	003911	1
6	Nut, 5/16-18 Hex	F05010-17	4
7	Screw, 5/16-18 x 1" Socket Head Flat Point Stainless Steel Set	F05006-122	1
8	Bolt, 5/16-18 x 1" Hex Head Stainless Steel	F05006-88	3
9	Shaft Weldment, Drive Side Guide	003913	1

10	Plate, Blade Guide Deflector	003916	1	
11	Bolt, 5/16-18 x 3/4" Hex Head w/Flat & Lock Washer	F05006-101	1	
	Roller Assembly, Blade Guide (standard for use with 1 1/4" & 1 1/2" blades)	A04925 ¹	1	
	Roller Assembly, Extended Blade Guide (optional for use with 1 1/2" blades)	014299 ¹	1	
	Bearing Kit, Blade Guide Rebuild	K07079	1	
12	Washer, 5/8" White Felt	P04252	1	
13	Ring, 1 1/8" Interior Retaining	F04254-1	1	
14	Bearing, R8-2RS Blade Guide	015975	2	◆
15	Washer, 5/8" Gray Felt	P06455	1	
	Screw, 1/4-28 x 1/4" Socket Head Cup Point Set Black Oxide	F05005-105	1	
	Instruction Sheet, Blade Guide Rebuild	057407-1507	1	
16	Roller, Flanged Blade Guide (1 1/4" & 1 1/2" blade)	S04250	1	◆
	Roller, Flanged Blade Guide (1 1/2" blade)	014298	1	◆
	Instruction Sheet, Blade Guide Roller Replacement	A04925-364	1	
17	Spacer, Blade Guide	S04253	2	
18	Washer, 1/2" Nord-Lock	F05011-125	1	
19	Bolt, 1/2-13 x 2 1/4" Hex Head Grade 5	F05008-10	1	
20	Washer, 5/16" SAE Flat	F05011-17	2	
21	Washer, 5/16" Split Lock	F05011-13	2	
22	Bolt, 5/16-18 x 1 1/2" Hex Head	F05006-76	2	
23	Bolt, Blade Guide Vertical Adjustment	035656	1	
24	Nut, 5/16-18 Hex	F05010-17	1	
25	Bolt, 5/16-18 x 2 3/4" Hex Head Full Thread	F05006-136	1	
	GUIDE KIT, HIGH-PERFORMANCE BLADE GUIDE (OPTIONAL)	006325 ²	1	
	Block Assembly, Drive Side Blade Guide	003927	1	
26	Plate, Block Tilt Adjustment	003915	1	
27	Block, Guide Block Mount	003909	1	
28	Pin, 3/16" x 5/8" Roll	F05012-22	2	
29	Washer, 3/8" SAE Flat	F05011-3	1	
30	Washer, 3/8" Split Lock	F05011-4	1	
31	Bolt, 3/8-16 x 1 1/4" Hex Head Grade 5	F05007-123	1	
32	Bolt, 5/16-18 x 3/4" Hex Head	F05006-102	1	
33	Ball, 3/16" Dia. Nylon	003914	2	
34	Washer, 1/4" Split Lock	F05011-14	2	
35	Bolt, 1/4-20 x 1/2" Hex Head	F05005-15	2	
36	Bolt, Blade Guide Block Mount	003994	1	
37	Washer, #10 Brass	042867	1	
38	Bolt, #10-32 x 1 1/4" Hex Head Stainless Steel	F05004-240	1	
39	Screw, Lower Block Adjustment	044057	1	
40	Screw, #10-32 x 3/8" Socket Head Stainless Steel	F05004-200	1	
41	Washer, 5/16" SAE Flat	F05011-17	1	
42	Washer, 5/16" Split Lock	F05011-13	1	

43	Block, Blade Guide Wear (Standard for 1 1/4" Blades)	052355 ³	2	
	Block, Blade Guide Wear (Optional for 1 1/2" Blades)	052309 ⁴	2	
	Block Assembly, 1" Sq. EZ-Glide Wear	036347 ⁴	2	
44	Block, Blade Guide Alignment	035799	1	
45	Washer, #10 Split Lock	F05011-20	1	
46	Screw, #10-32 x 5/8" Hex Head	F05004-152	1	
47	Adjustment Tool, Lower Guide Block	044064	1	
	Shim, .008" Blade Guide Block Spacer	035248	1	
Idle Side Blade Guide Parts (Voir Partie 2.1)				
	ROLLER ASSEMBLY, BLADE GUIDE RELUBE (OPTIONAL FOR USE WITH 1 1/4" OR 1 1/2" BLADES)	016568 ¹	1	
	ROLLER ASSEMBLY, EXTENDED BLADE GUIDE RELUBE (OPTIONAL FOR USE WITH 1 1/2" BLADES)	057405 ¹	1	
	Bearing Kit, Relube Blade Guide Rebuild	057407	1	
48	Washer, 5/8" White Felt	P04252	1	
49	Ring, 1 1/8" Interior Retaining	F04254-1	1	
50	Bearing, R8-2RS Blade Guide	015975 ⁴	2	◆
51	Washer, 5/8" Gray Felt	P06455	1	
52	Spacer, Blade Guide Bearing	035411	1	
	Instruction Sheet, Blade Guide Rebuild	057407-1507	1	
53	Roller, Flanged Blade Guide (Relube 1 1/4" & 1 1/2" blade)	035426	1	◆
	Roller, Flanged Blade Guide (Relube 1 1/2" blade)	057402	1	◆
	Instruction Sheet, Blade Guide Roller Replacement	A04925-364	1	
54	BOLT, BLADE GUIDE ROLLER (RELUBE ONLY)	036161	1	
55	FITTING, 1/4-28 GREASE (RELUBE ONLY)	P05060	1	

¹ The sawmill is equipped standard with non-greasable blade guide rollers that can be used with the standard 1 1/4" blade or 1 1/2" blades. Optional extended blade guide rollers are available for use with 1 1/2" blades. The extended rollers may provide more stability during difficult sawing, but will reduce the total amount of times the blade can be reused after sharpening. Use kit 006382 to convert the rollers and guide blocks for both blade guides for 1 1/2" blades. Optional relube versions of each roller configuration are also available.

² High-Performance Blade Guide Kit requires LMS blade lube system. Use kit 006325 to upgrade both drive and idle side blade guides to High-Performance. If sawmill not already equipped with LMS, add kit LMS-A.

³ 052355 blocks for use with 1 1/4" blade provided as standard equipment. 052309 blocks available for optional use with 1 1/2" blades. Use kit 006382 to convert the rollers and guide blocks for both blade guides for 1 1/2" blades. EZ-Glide blocks 036347 are available for customers who prefer this block.

⁴ Bearing must be modified for use with relube roller assemblies. Remove one seal from each bearing, place open sides facing each other and place spacer 035411 between bearings.

1.3 Système D'entraînement De Bras De Guidage

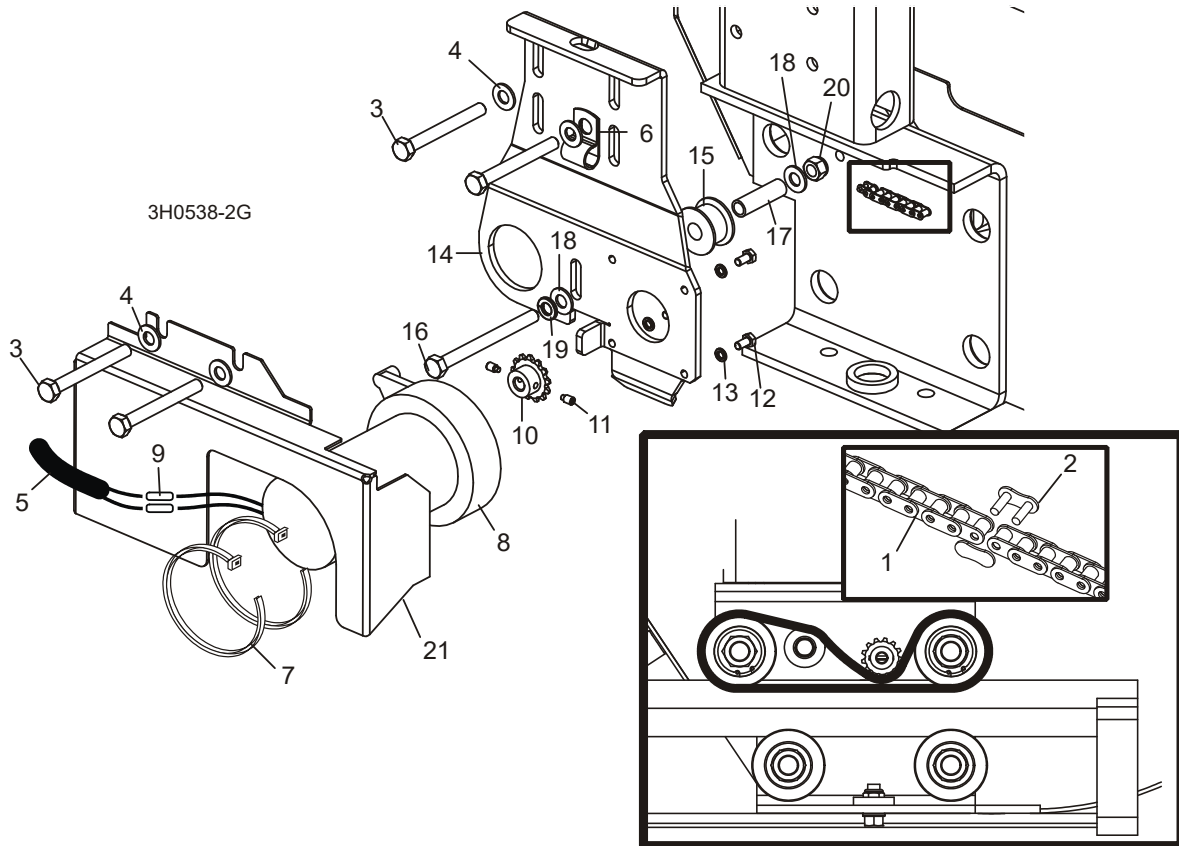

REF	PART #	QTY.
1	P09984	1
2	P09983	1
3	F05006-28	4
4	F05011-17	4
5	R01897	2.5ft
6	P07584	2
7	F05089-1	2
8-20	015989	1
8-13	079215	1
8	079214	1
	061232	1
	061234	1
	061233	1
9	F04875-1	2
10-11	P09970	1

11	F05004-274	2
12	F05004-60	4
13	F05011-20	4
14	015939	1
15	S09999	1
16	F05006-3	1
17	S09996-W	1
18	F05011-17	2
19	F05011-13	1
20	F05010-58	1
21	S11617	1

1.4 Bras de Guidage de Lame

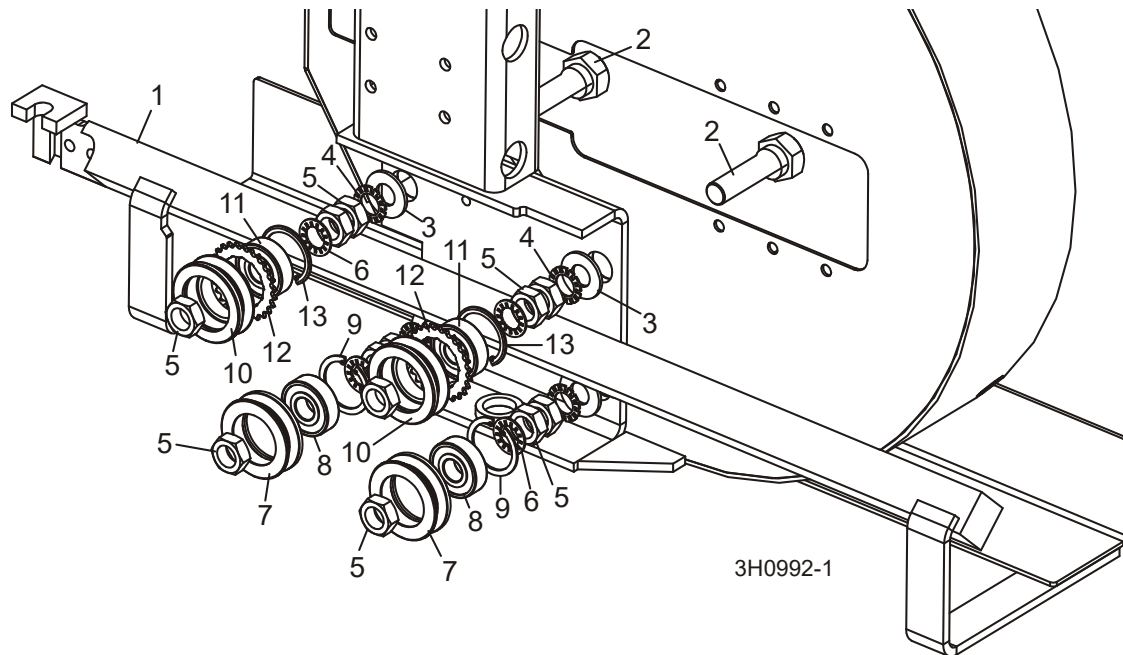

REF	PART #	QTY.
1	003972	1
1	007040 (Wide)	1
2	W09067	4
3	F05011-5	4
4	F05011-26	4
5	F05010-11	12
6	F05011-25	8
7-9	A09059	2
7	S07989	1
8	P06030-1	1
9	F04254-8	1
10-13	A09932	2
10	S09930	1
11	P06030-1	1
12	S09931	1
13	F04254-8	1

PARTIE 2 POULIES ET TENDEUR

2.1 Système D'entraînement De Lame

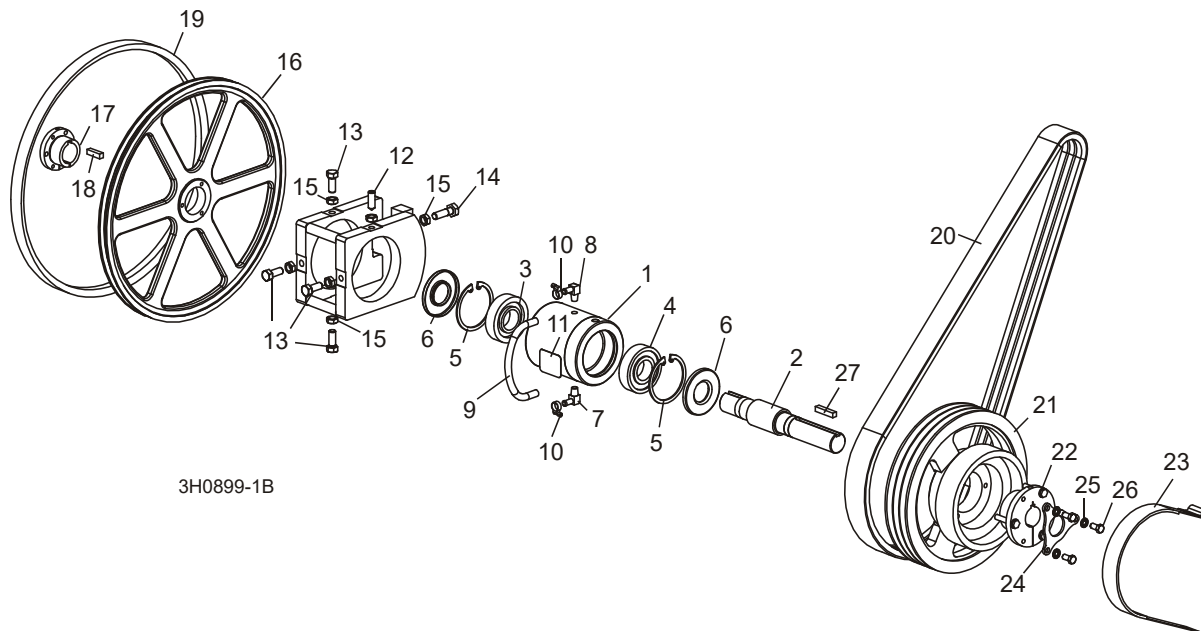

3H0899-1B

REF	PART #	QTY.
1-11	016393	1
1-6	----	1
1	----	1
2	----	1
3	----	1
4	----	1
5	F04254-17	2
6	P10206	2
7	016330	1
8	016331	1
9	016394	1
10	P649	2
11	017470	1
12	F05004-170	1
13	F05008-108	4
14	F05008-49	1
15	F05010-16	6
16-18	014562	1
16	016284	1

17	016270	1
18	S12892	1
19	P04185	1
20	065400 ¹	1
	046571 ²	1
	016557 ³	1
21	016531	1
22	016532	1
23	014391	1
24	017953	1
25	F05011-4	3
26	F05007-27	3
27	014693	1

¹ E25 60Hz

² D47/D51

³ E25 50Hz

2.2 Poulie Folle

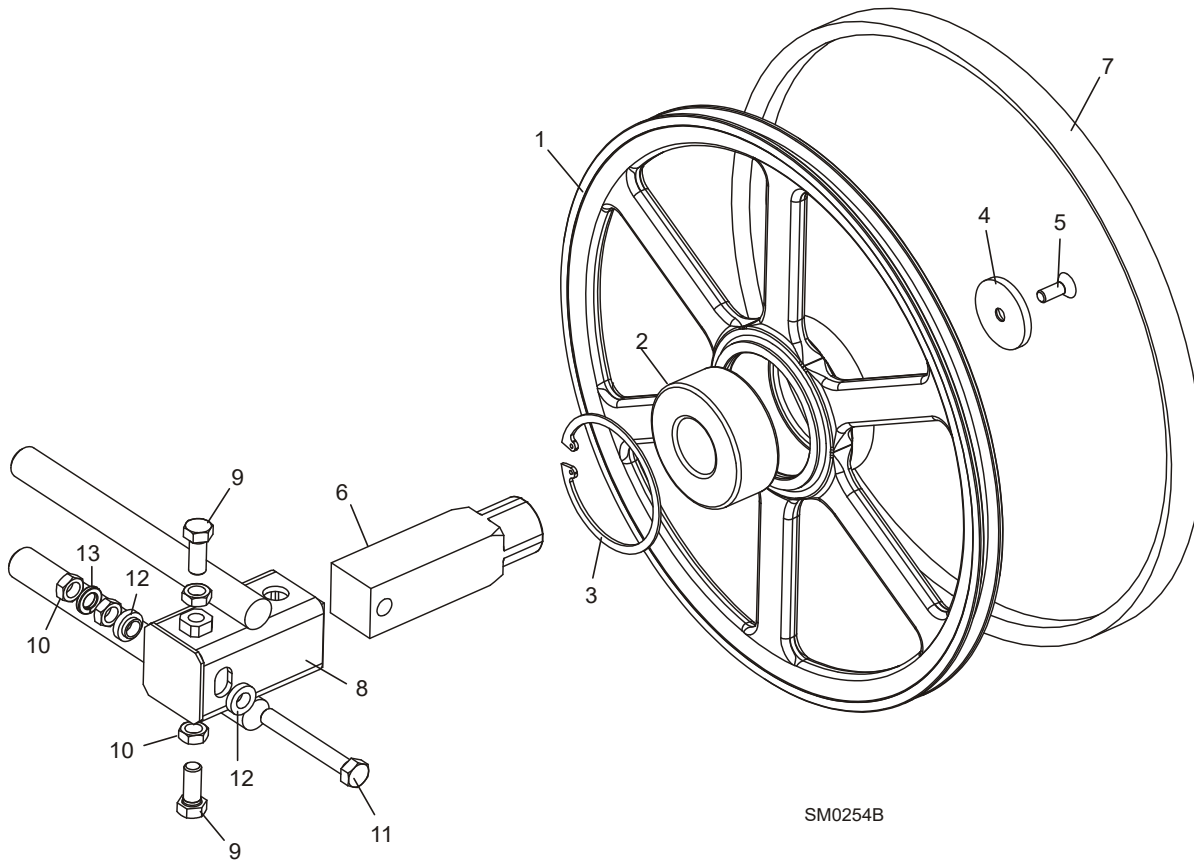

REF	PART #	QTY.
1-3	016120	1
1	----	1
2	016014	1
3	F04254-28	1
4-6	016441	1
4	016397	1
5	F05007-64	1
6	016398	1
7	P04185	1
8	016103	1
9	F05008-53	2
10	F05010-16	4
11	F05008-111	1
12	S04253	2
13	F05011-9	1

2.3 Tendeur Hydraulique De Lame

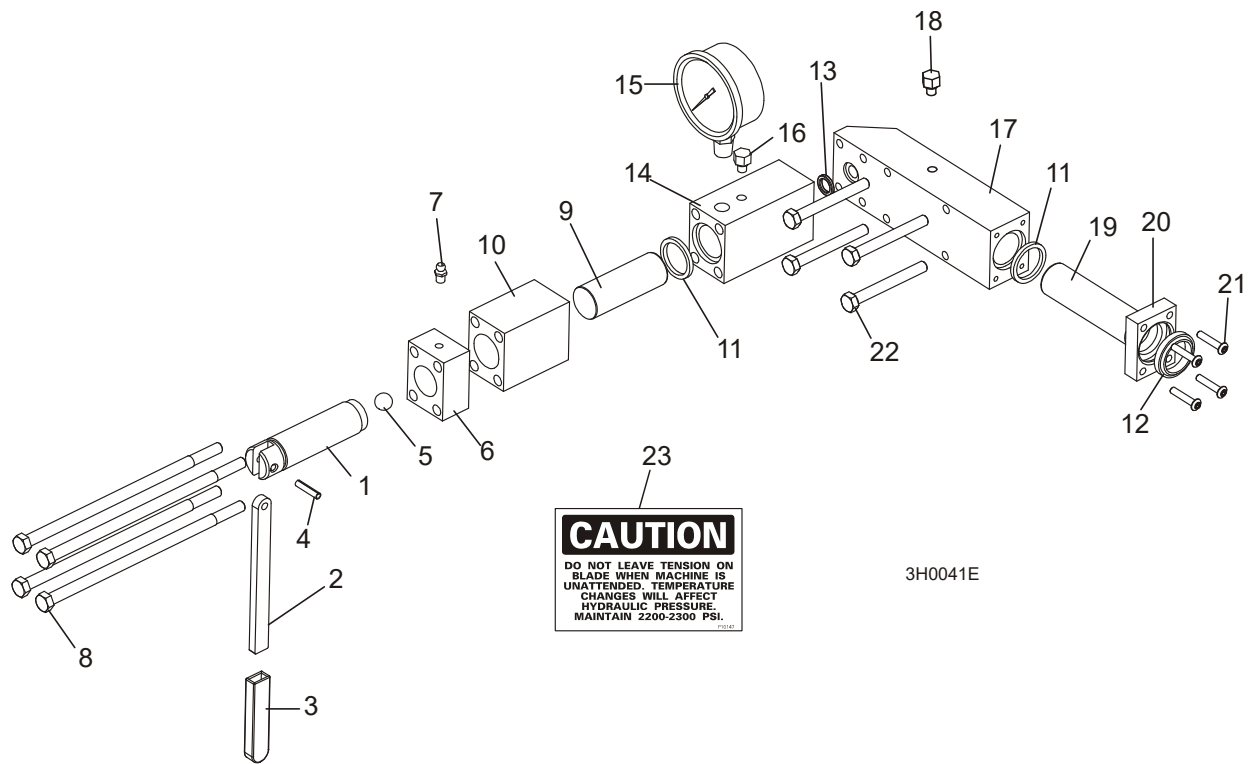

REF	PART #	QTY.
1-22	A10136	1
1-7	A12294	1
1	S10056	1
2	S08174	1
3	P08072	1
4	F05012-19	1
5	P02720	1
6	----	1
7	P05060	1
8	F05006-43	4
9	S10060	1
10	S10061	1
5, 11-13	003224	1
5	P02720	1
11	P10051	2
12	P10053	1
13	P10377	1

14	S10140	1
15	P10052	1
16	P10065	1
17-18	016329	1
17	-----	1
18	P10065	1
19	S10059	1
20	S10089	1
21	F05004-43	4
22	F05006-28	4
23	P10147	1

PARTIE 3 TÊTE DE SCIE

3.1 Vis Anti-Vibration

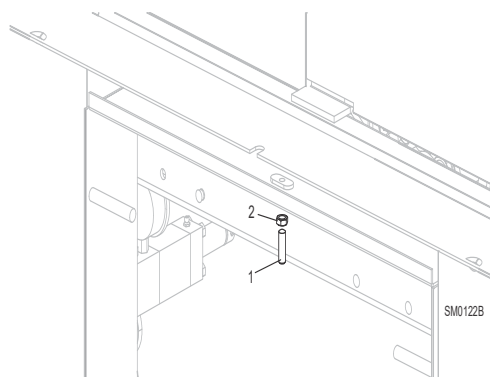

REF	PART #	QTY.
1	F05007-18	1
2	F05010-29	1

3.2 Valve Du Contrôle De Lubrification

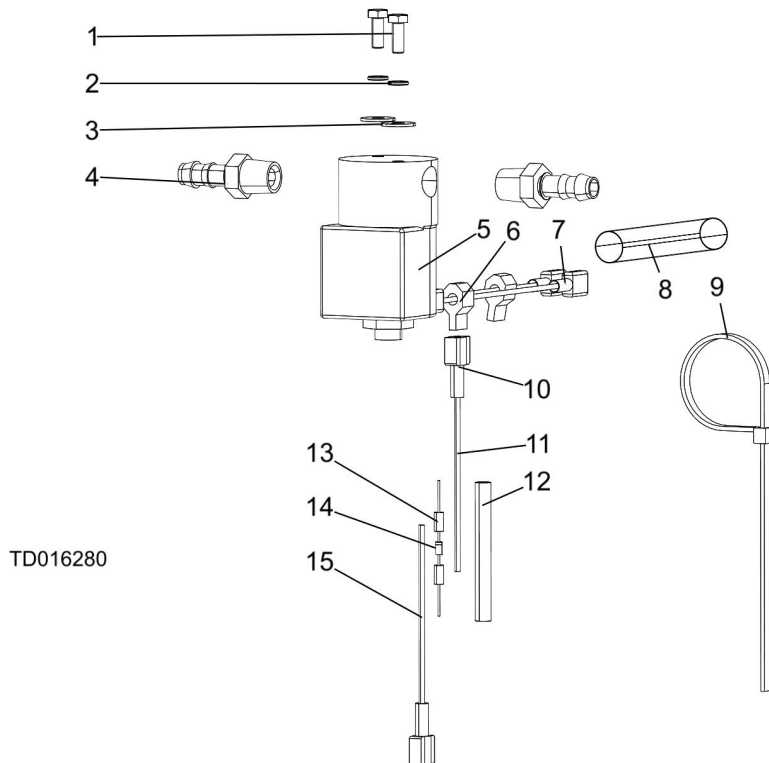

REF	PART #	QTY.
	016280	
1	F05004-60	2
2	F05011-20	2
3	F05011-18	2
4	P04682	2
	133071	1
5	016140	1
6	F04875-13	2
7	F05708-21R	2
8	R02374	1
9	F05089-3	1
	024123	1
10	F05708-22R	2
11	R01915-3_3	1
12	R01950-4_2_14	1
13	024032	2
14	E05909	1
15	R01915-0_3	1

3.3 Système D'embrayage (D47/D51)

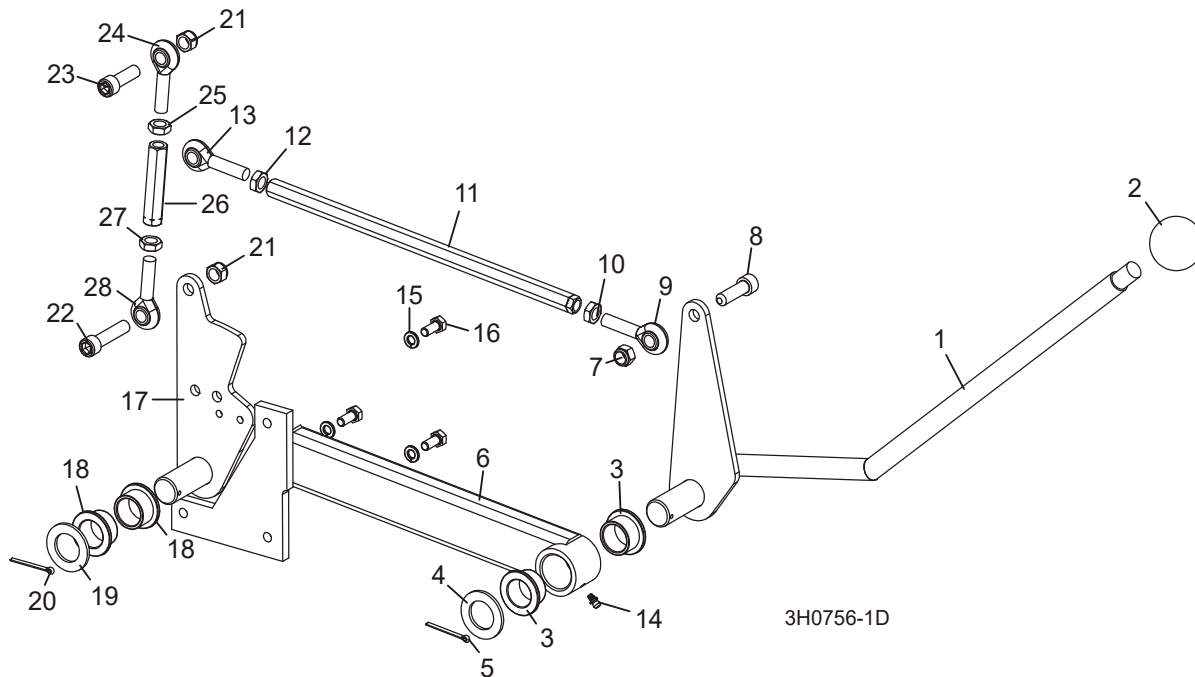

REF	PART #	QTY.
1-14	016317	1
1	-----	1
2	P04211	1
3	P737	2
4	P116	1
5	F05012-49	1
6	015241	1
7	F05010-83	1
8	F05007-55	1
9	P11578	1
10	F05010-87	1
11	015073	1
12	F05010-38	1
13	P11579	1
14	P04107	1
15	F05011-13	3
16	F05006-5	3
17	016296	1
18	P737	2
19	P116	1
20	F05012-49	1

21	F05010-83	2
22	F05007-120	1
23	F05007-55	1
26-28	A11576	1
24	P11579	1
25	F05010-38	1
26	-----	1
27	F05010-87	1
28	P11578	1

3.4 Système D'embrayage (E25)

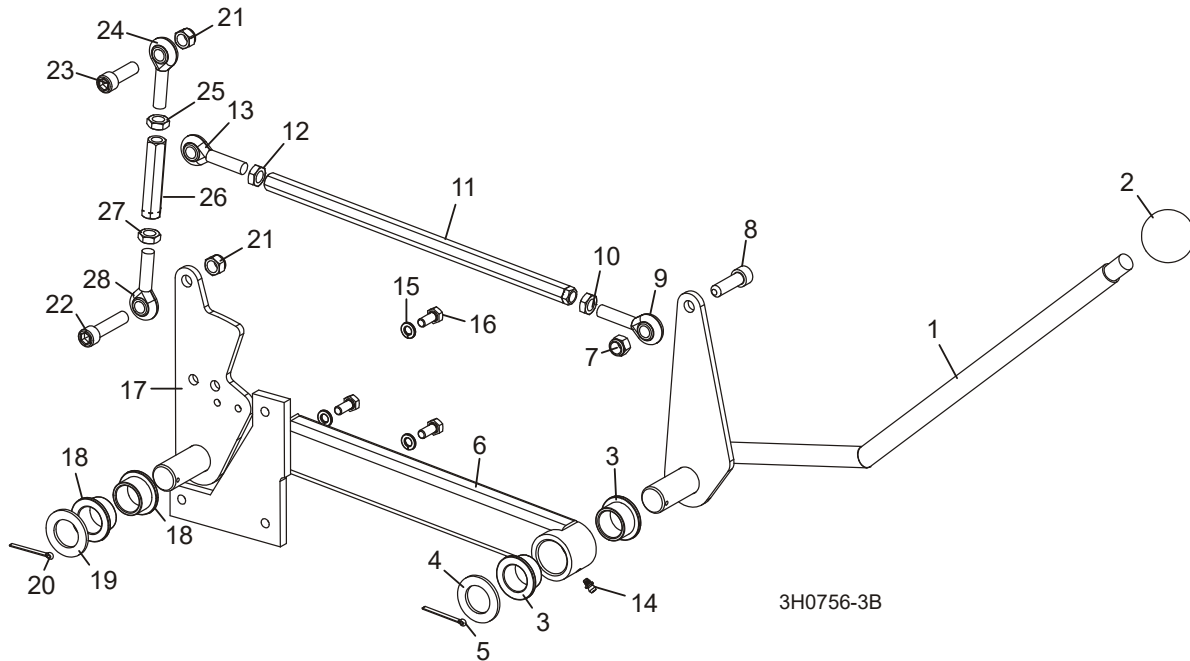

REF	PART #	QTY.
1-14	016317	1
1	-----	1
2	P04211	1
3	P737	2
4	P116	1
5	F05012-49	1
6	015241	1
7	F05010-83	1
8	F05007-55	1
9	P11578	1
10	F05010-87	1
11	015073	1
12	F05010-38	1
13	P11579	1
14	P04107	1
15	F05011-13	3
16	F05006-5	3
17	016296	1
18	P737	2
19	P116	1
20	F05012-49	1

21	F05010-83	2
22	F05007-120	1
23	F05007-55	1
25-29	A12304 ¹	1
	A11576 ²	1
24	P11579	1
25	F05010-38	1
26	-----	1
27	F05010-87	1
28	P11578	1

¹ G38 & 60Hz E25

² 50Hz E25

3.5 Fixation d'embrayage

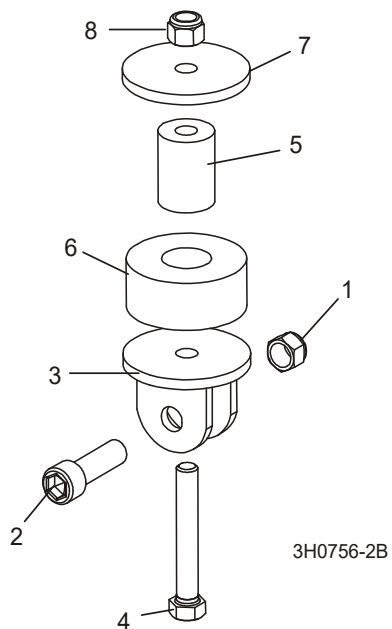

REF	PART #	QTY.
1	F05010-83	1
2	F05007-55	1
3	W12411	1
4	F05007-157	1
5	016316	1
6	P05032	1
7	021276	1
8	F05010-10	1

3.6 Système De Freinage

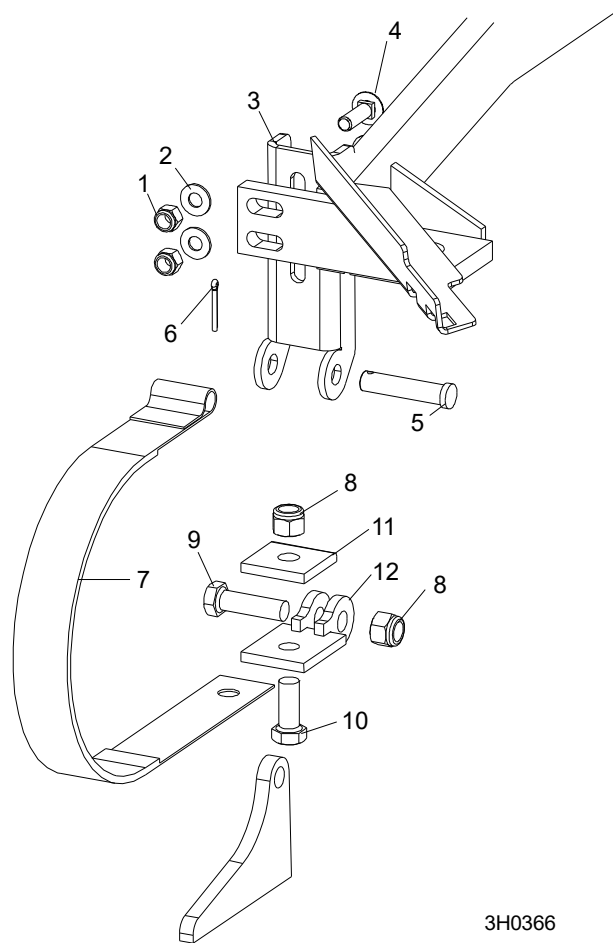

3H0366

REF	PART #	QTY.
1-12	014441	1
1	F05010-10	2
2	F05011-3	2
3	014395	1
4	F05007-127	2
5	F05012-81	1
6	F05012-1	1
7	014391	1
8	F05010-8	2
9	F05008-88	1
10	F05008-37	1
11	S04195	1
12	014392	1

3.7 Éjecteur De Planches

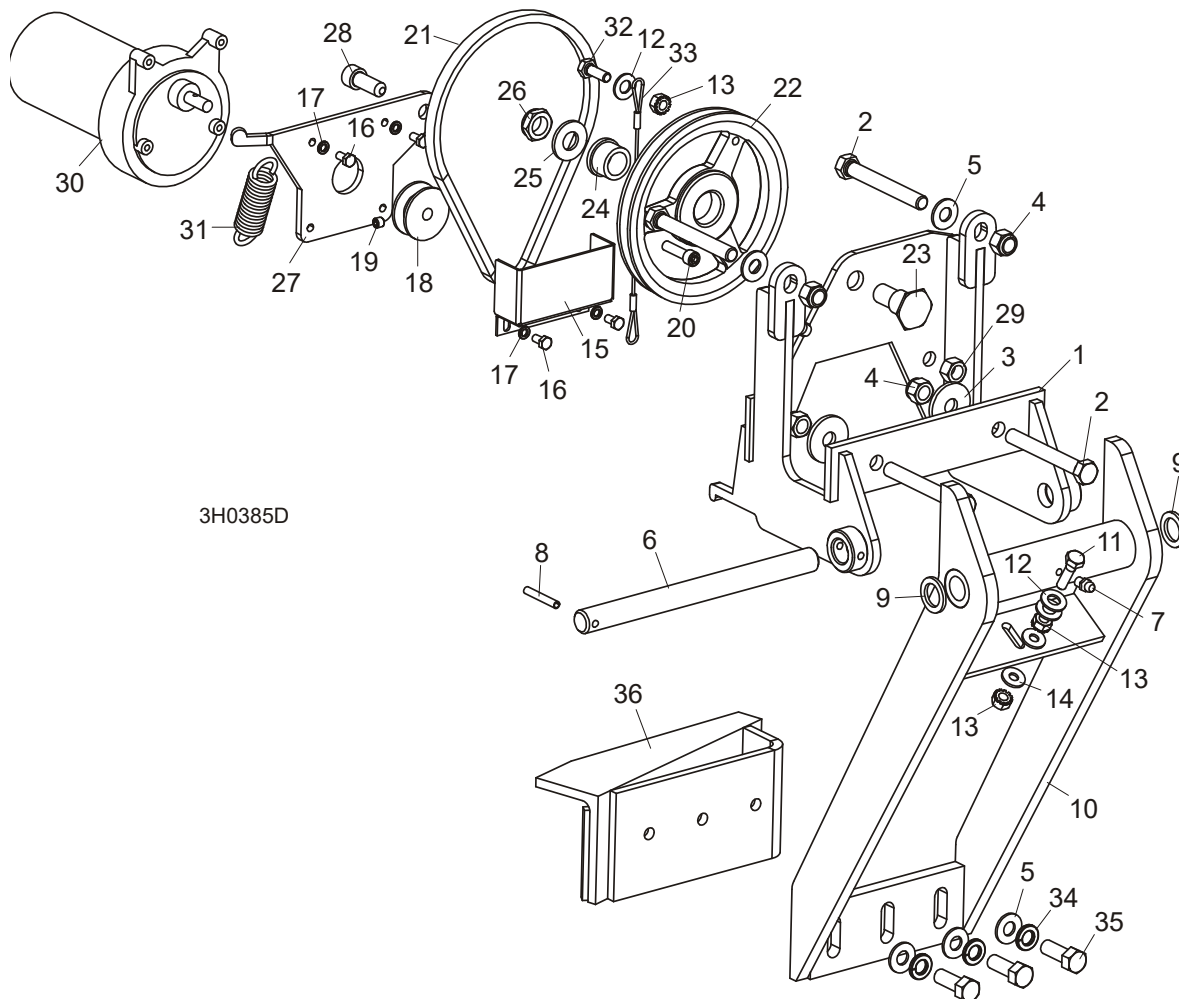

REF	PART #	QTY.
1-36	015209	1
1	015215	1
2	F05007-1	4
3	015336	2
4	F05010-10	4
5	F05011-3	5
6	016272	1
7	P05060	1
8	F05012-16	1
9	F05011-19	2
10	015210	1
11	F05005-1	1

12	F05011-17	3
13	F05010-9	3
14	F05011-11	2
15	015007	1
16	F05004-60	4
17	F05011-20	4
18	015074	1
19	F05005-105	1
20	F05005-89	1
21	015477	1
22	015224	1
23	015221	1
24	P05135	1

25	F05011-2	1
26	F05010-79	1
27	015220	1
28	F05007-52	1
29	F05010-25	1
30	079214	1
	061232	1
	061234	1
	061233	1
31	015479	1
32	F05005-101	1
33	016090	1
34	F05011-4	3

35	F05007-7	3
36	015652	1

3.8 Système De Lubrification (Gas)

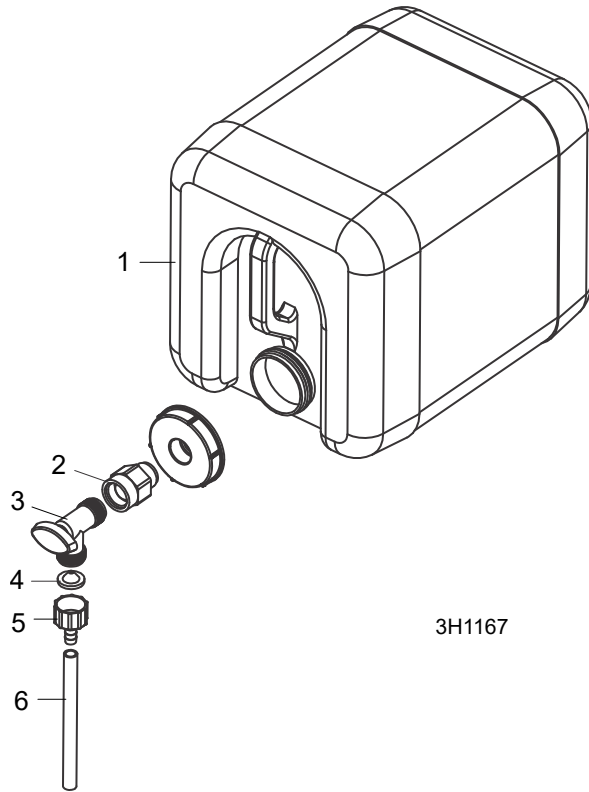

REF	PART #	QTY.
1	014642	1
2	014636	1
3	014100	1
4	016086 ¹	1

5	014113	1
6	R01885	7 ft.
	CBOTTLE	1

¹ Filter recommended for Super models to prevent debris from entering water lube solenoid valve.

3.9 Système De Lubrification (Diesel & Electric)

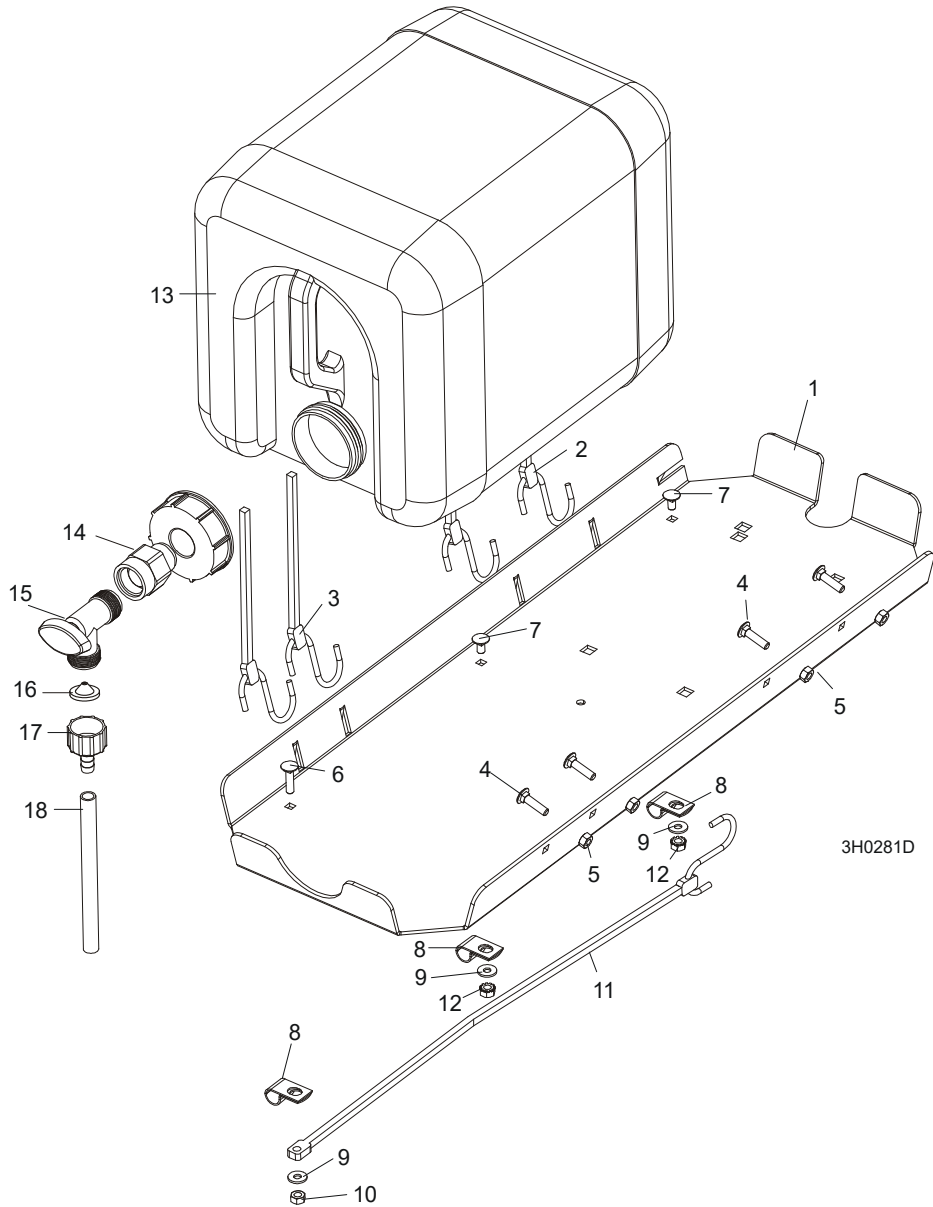

REF	PART #	QTY.
1-5	A11685	1
1	S11684	1
2	P11258	2
3	P11668	2
4	F05005-34	4
5	F05010-21	4

6	F05005-34	1
7	F05005-33	2
8	P07584	3
9	F05011-11	3
10	F05010-21	1
11	P07461	1
12	F05010-9	2
13	014642	1

14	014636	1
15	014100	1
16	016086	1
17	014113	1
18	R01885	7 ft.

3.10 Étiquettes D'avertissement

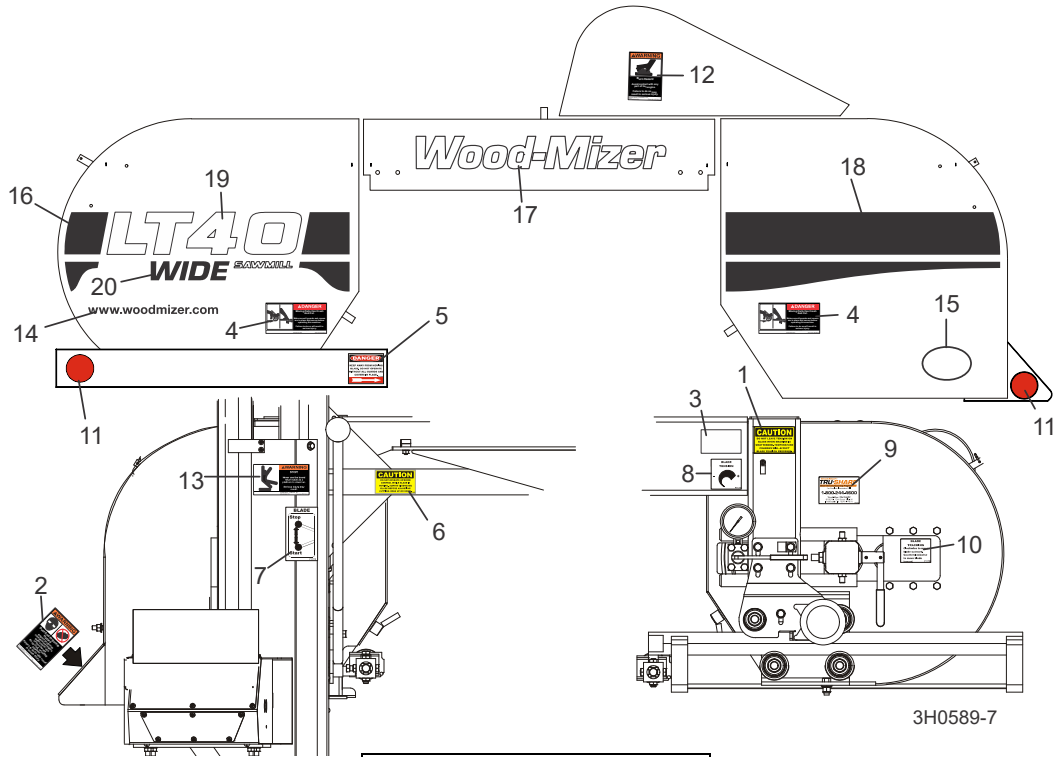

20	074335	1
----	--------	---

REF	PART #	QTY.
1	P10147	1
2	P11754	1
3	P12373	1
4	033254	2
5	S11752	1
6	S11762	1
7	P11779	1
8	P11790	1
9	P12879	1
10	P11789	1
11	P07452	2
12	014419	1
13	016072	1
14	003235	1
15	065582	1
16	065023	1
17	065025	1
18	065026	1
19	065024	1

3.11 Couvercles De Carters De Lame

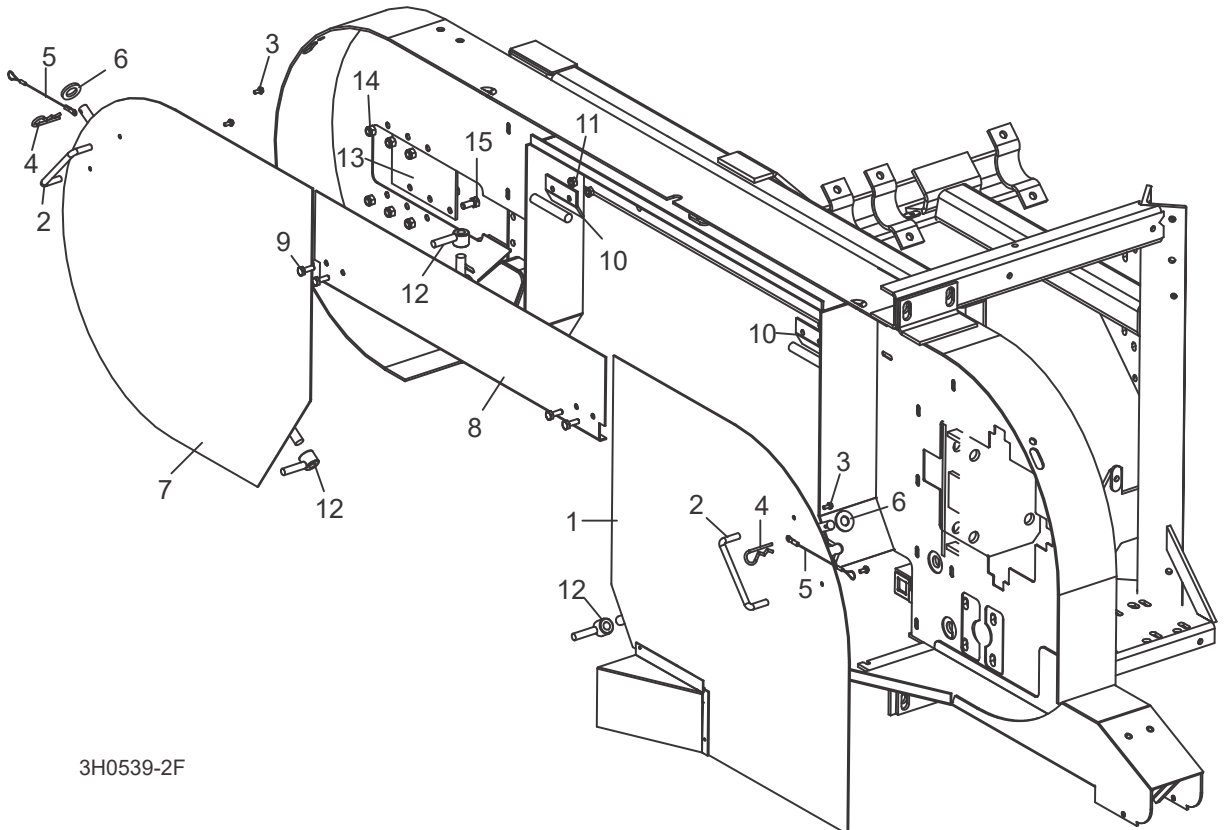

3H0539-2F

REF	PART #	QTY.
1-8	015937	1
1	----	1
2	P08065	1
3	F05015-8	2
4-5	A12812	1
4	P05059	1
5	016030	1
6	F05011-87	1

2-5, 6-7	A09419	1
7	----	1
2	P08065	1
3	F05015-8	2
	A12812	1
4	P05059	1
5	016030	1
8	F05011-87	1
8	W07409	1

8	079509 (Wide)	1
9	F05005-1	18
10	S07522	2
11	F05010-9	4
12	021145	3
13	S04433	1
14	F05010-58	6
15	F05006-5	6

3.12 Couvercles De Carters De Courroies

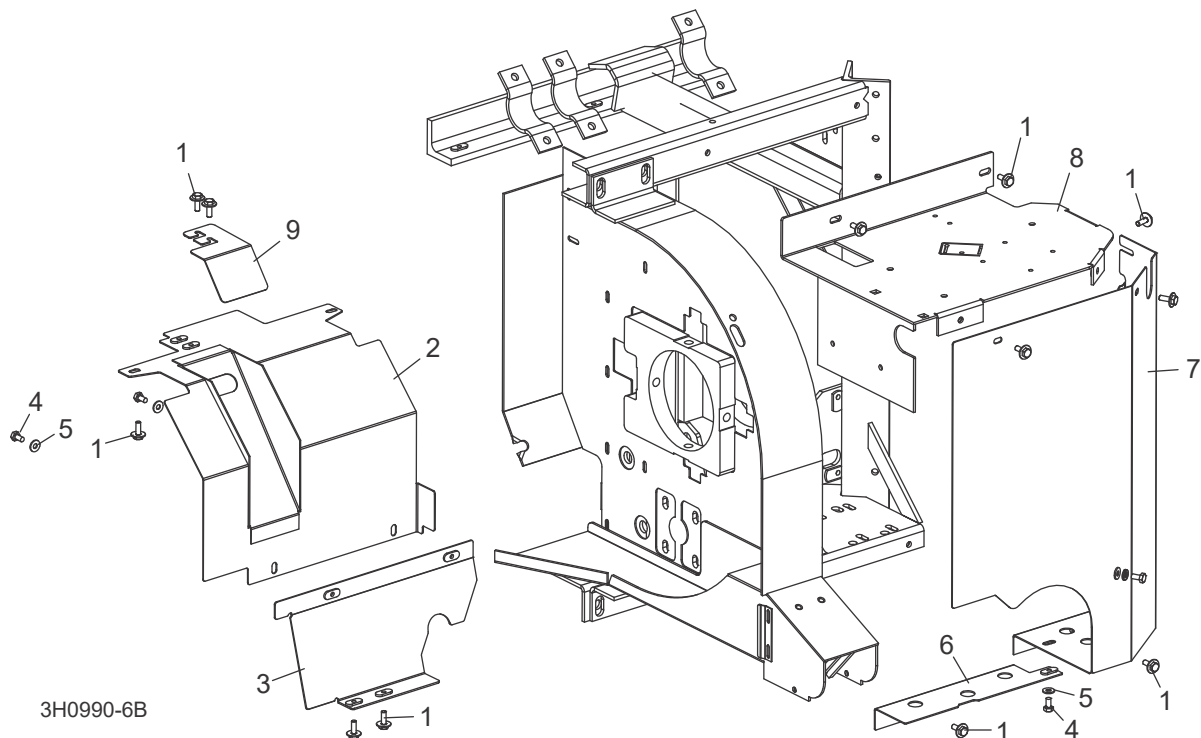

REF	PART #	QTY.
1	F05005-134	13
2	006026	1
3	006025	1
4	F05005-15	3
5	F05011-11	3
6	015654	1
7	008776	1
8	059599	1
9	074752	1

3.13 Chute À Bran De Scie

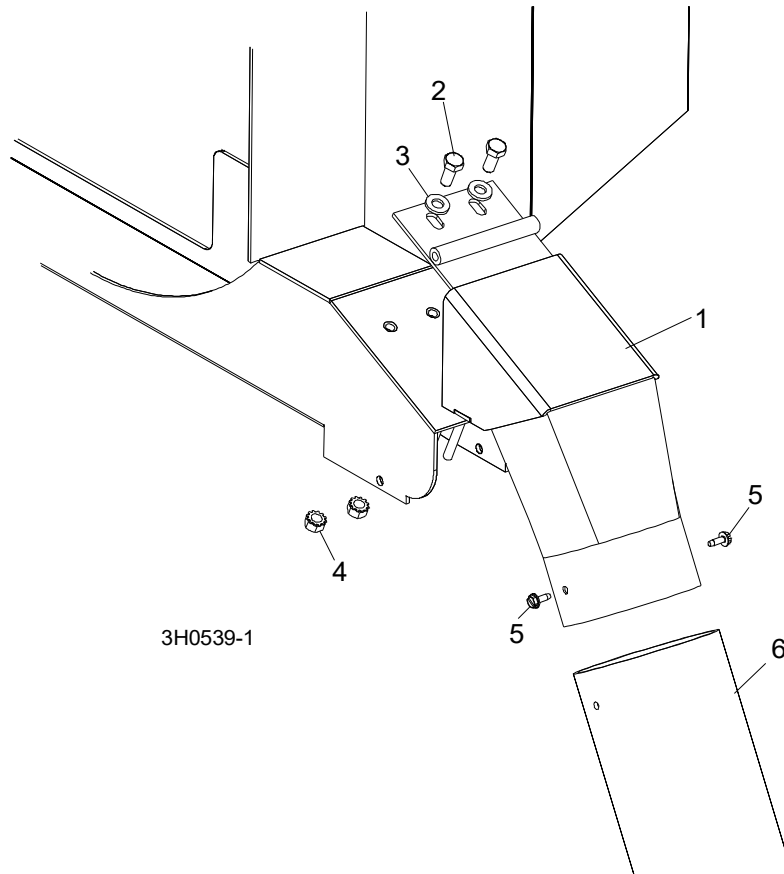

REF	PART #	QTY.
1	015466	1
2	F05006-5	2
3	F05011-17	2
4	F05010-20	2
5	F05015-7	2
6	016727	1

3.14 Boîte De Filage De L'écorceuse Et Obturateurs

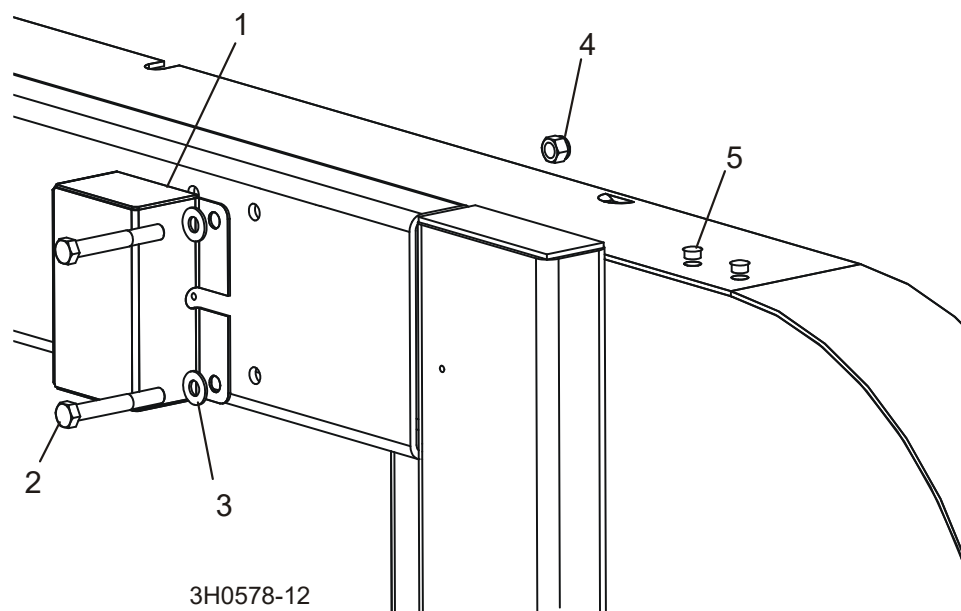

3H0578-12

REF	PART #	QTY.
1	023616	1
2	F05007-29	2
3	F05011-3	2
4	F05010-10	2
5	014537	2

PARTIE 4 SYSTÈME DE COMMANDE ET BATTERIE

4.1 Système De Commande

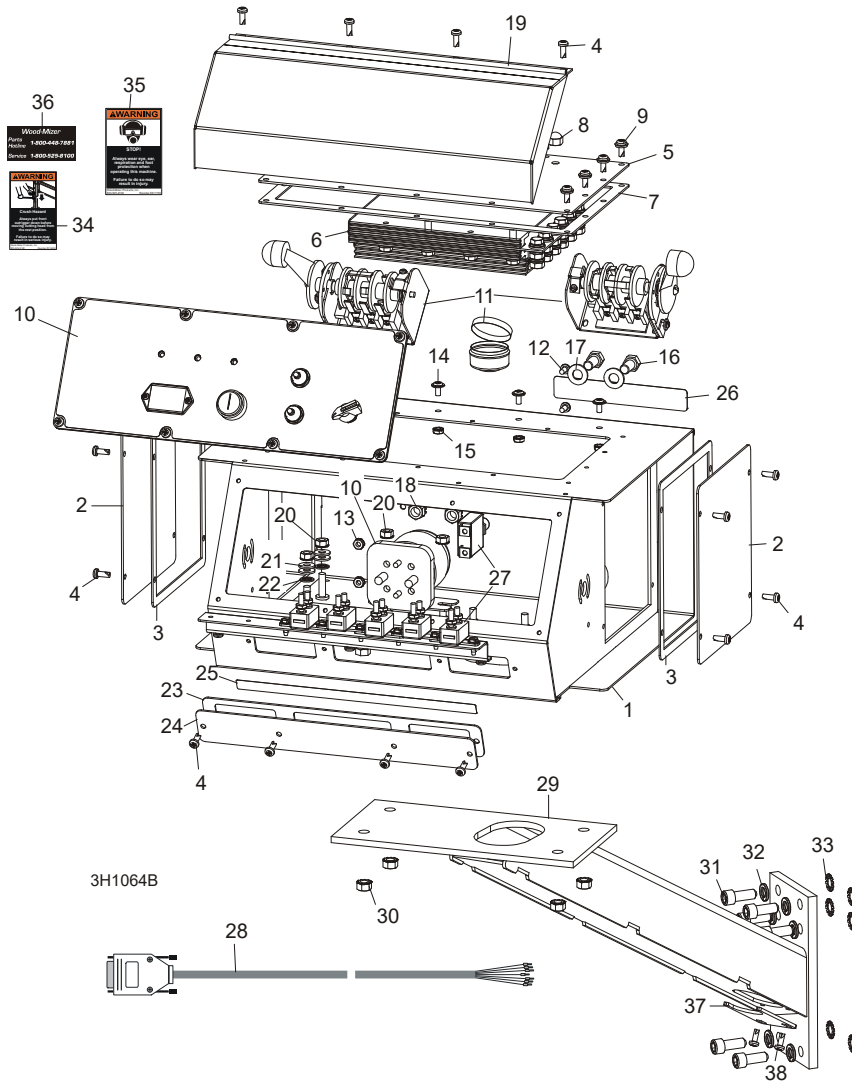

REF	PART #	QTY.
1-28	069426	1
1-28	069422	1
1	-----	1
2	006473	2
3	015274	2
4	F05015-17	16
5-8	069415	1

5	059648	1
6	057821LS-FR	1
7	069413	1
8	F05010-204	4
9	F05004-186	14
10	See Section 4.4	
11	See Section 4.2	
12	F05004-3	2

13	F05010-14	2
14	F05004-148	4
15	F05010-14	4
16	F05007-27	2
17	F05011-3	2
18	F05010-19	2
19	015304	1
20	F05010-9	4

4**Système De Commande Et Batterie**

21	F05011-11	4
22	F05011-69	2
23	015266	1
24	015376	1
25	069412	1
26	069414	1
27	See Section 4.3	
28	053355	1
29	015236	1
30	F05010-20	4
31	F05007-52	6
32	F05011-4	6
33	F05011-36	6
34	015400	1
35	S11753	1
36	S12117	1
37	036381	1
38	F05015-17	2

4.2 Commutateurs

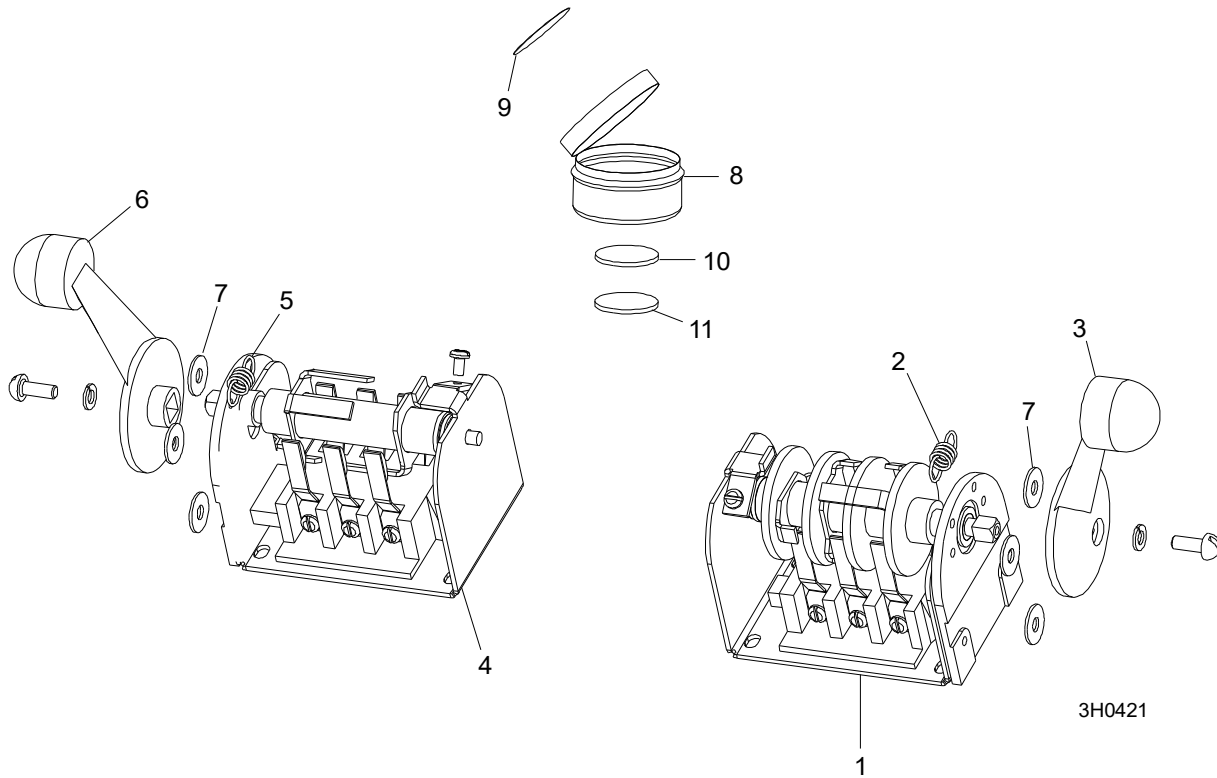

REF	PART #	QTY.
1-3	E20440	1
1	-----	1
2	P12570	1
3	P12500	1
4-6	E20439	1

4	-----	1
5	P12570	1
6	P12500	1
7	F05011-41	6
9-12	A20463	1
8	-----	1

9	P20467	1
10	-----	1
11	-----	1

4.3 Disjoncteurs

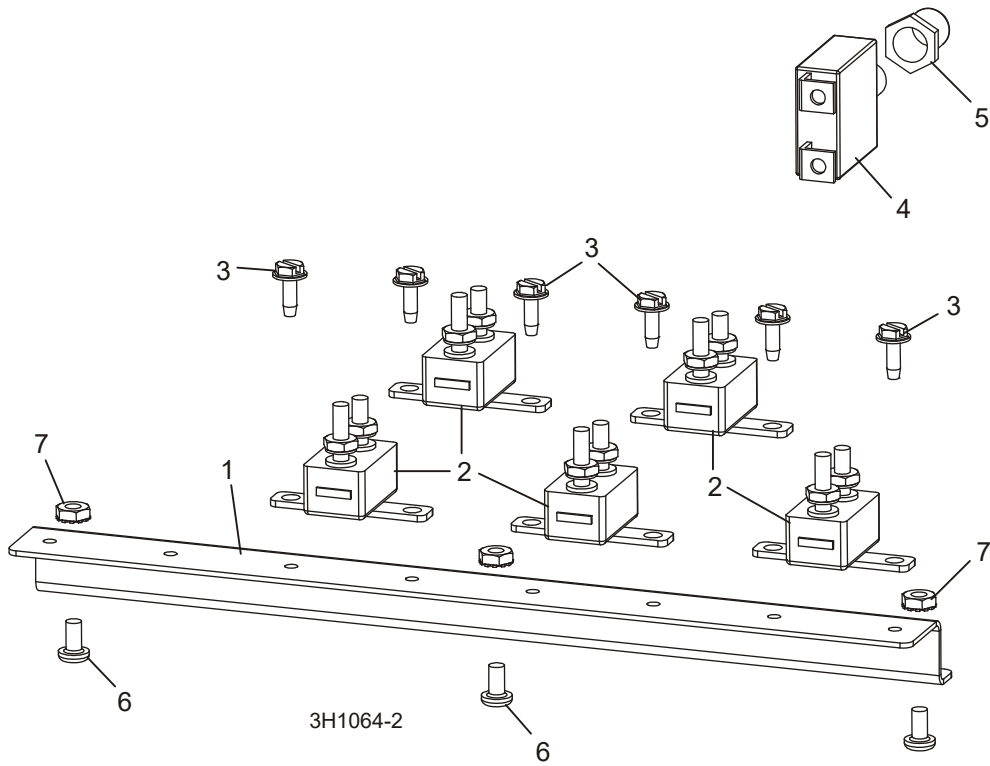

REF	PART #	QTY.
1-3	015621	1
1	052826	1
2	E20430	5
3	F05015-7	6
4	015527	1
5	021253	1
6	F05004-3	3
7	F05010-14	3

4.4 Panneau De Commande

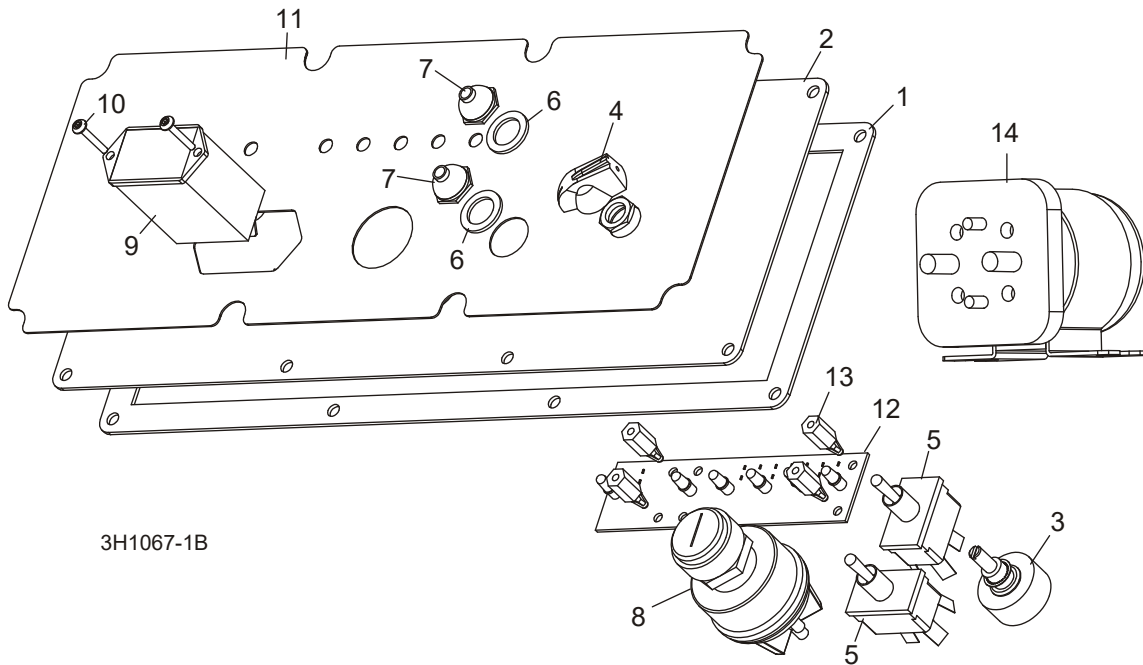

3H1067-1B

REF	PART #	QTY.	
	069417	1	E25
	069416	1	D47
1	015270	1	
2	015302	1	
3	024450-1	1	
4	P06257	1	
5	024200	2	
6	P02575	2	
7	P05251-1	2	
8	P04350	1	
9	015401	1	
10	F05015-28	2	
11	015271	1	E25
	015269	1	D47
12	015416	1	E25
	015409	1	D47
13	023147	4	
14	016371	1	
	015470	1	◆
	015426	1	

4 Systeme De Commande Et Batterie

Panneau De Commande

	069343	1	E25
	069309	1	D47
	050399	1	
	024402	1	
	051872	1	
	R02374	41 in.	
	R02374	42 in.	

4.5 Boîte De Batterie

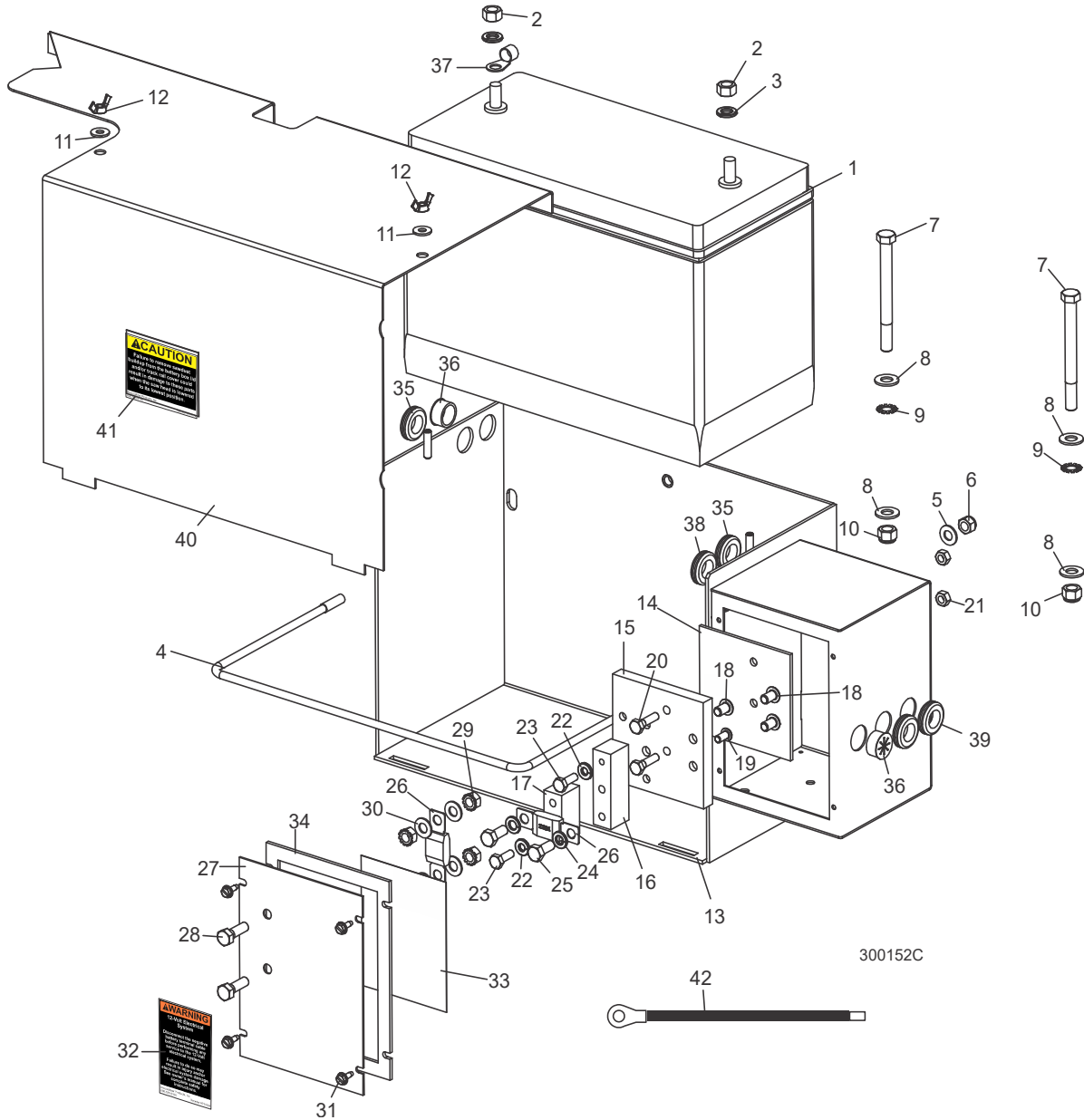

REF	PART NUMBER	QTY.
1	025841	1
2-39	015476	1
2	F05010-1	2
3	F05011-4	2
4	015194	1
5	F05011-17	2

6	F05010-58	2
7	F05007-4	2
8	F05011-3	4
9	F05011-36	2
10	F05010-10	2
11	F05011-11	2
12	F05010-13	2

13	015191	1
14-25	006850	1
14	056999	1
15	056997	1
16	056996	1
17	056998	1
18	F05006-20	3

4**Système De Commande Et Batterie***Boîte De Batterie*

19	F05005-59	1
20	F05005-101	2
21	F05010-21	2
22	F05011-14	2
23	F05005-123	2
24	F05011-13	2
25	F05006-102	2
26	053339	2
27-30	006854	1
27	006851	1
28	F05006-1	2
29	F05010-20	4
30	F05011-17	4
31	F05015-7	4
32	P10364	1
33	006866	1
34	050283	1
35	P11764	5
36	P04137	2
37	F05092-28	2
38	074198	2
39	074199	2
40	015771	1
41	014774	1
42	036308	1

PARTIE 5 SYSTÈME DE MONTÉE

5.1 Fixation De La Tête De Sciage

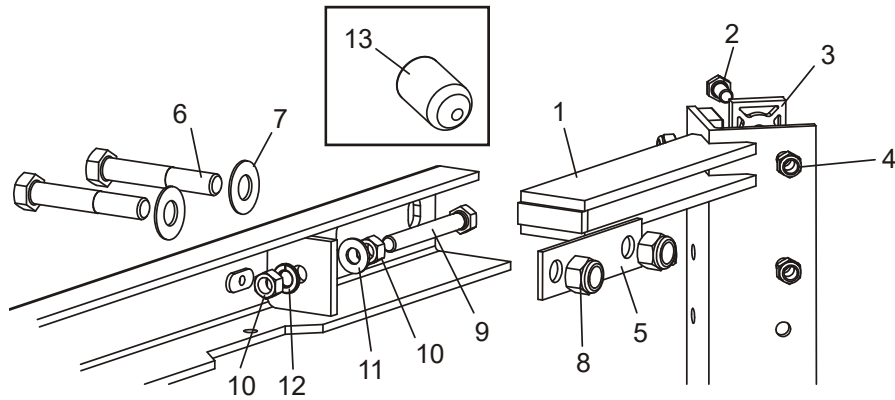

SM0080D

REF	PART #	QTY.
1	W04099	1
2	F05006-5	12
	F05006-93	4
3	M04096	6
	016241	2

4	F05010-58	16
5	S07935	2
6	F05008-61	4
7	F05011-2	4
8	F05010-8	4
9	F05007-17	2

10	F05010-1	4
11	F05011-3	2
12	F05011-4	2
13	017715	3

5.2 Indicateur De Hauteur Et Règles De Débitage

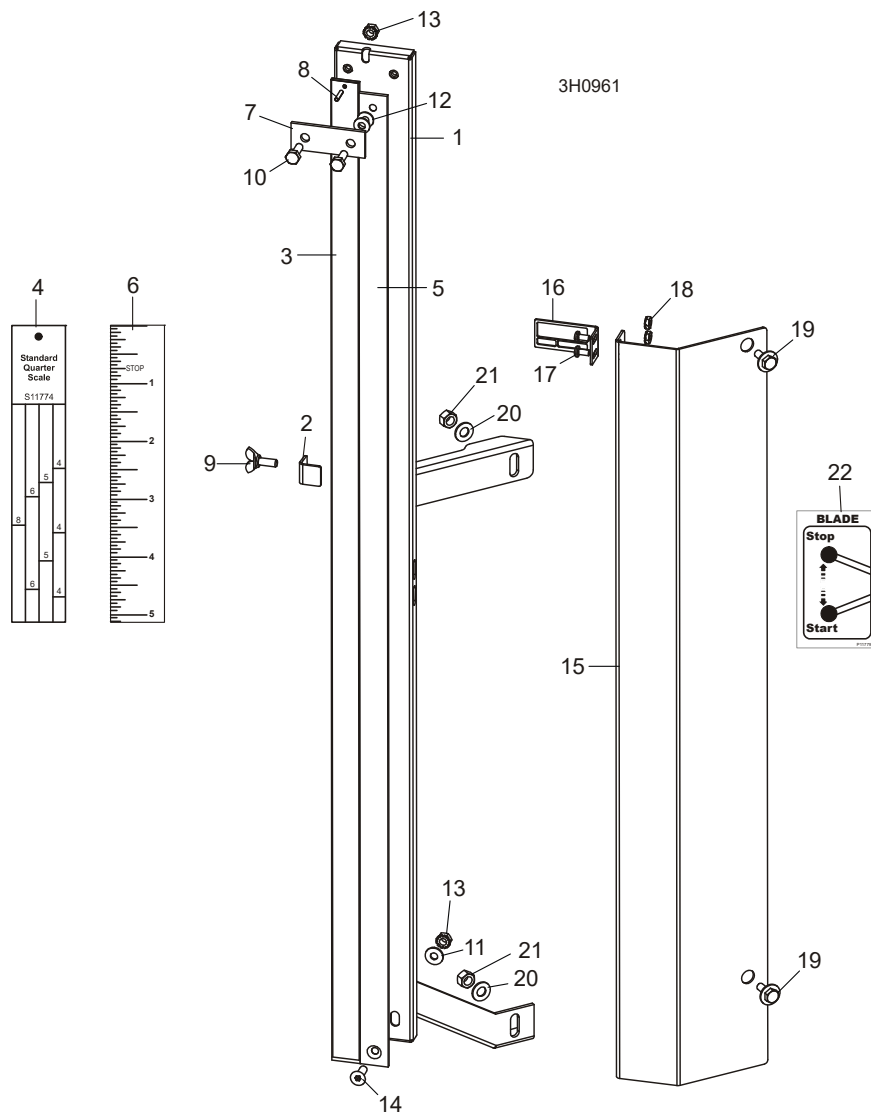

REF	PART #	QTY.
1-21	A12030	1
1-21	-----	1
1-14	-----	1
1-2	W11996	1
2	036666	1
3-4	S11989	1
4	S11774 ¹	1
	P12819 ²	1
5-6	S11988	1

6	S11773	1
7	S04805	1
8	F05012-14	1
9	F05005-64	1
10	F05005-1	2
11	F05011-11	1
12	F05011-22	2
13	F05010-9	2
14	F05005-70	1
15-18	038591	1

15	038586	1
16	038585	1
17	F05004-3	2
18	F05010-14	2
19	F05005-134	2
20	F05011-17	2
21	F05010-6	2
22	P11779-5	1

¹ Standard
² Pour Bois Dur

5.3 Chaînes Et Pignons De Montée

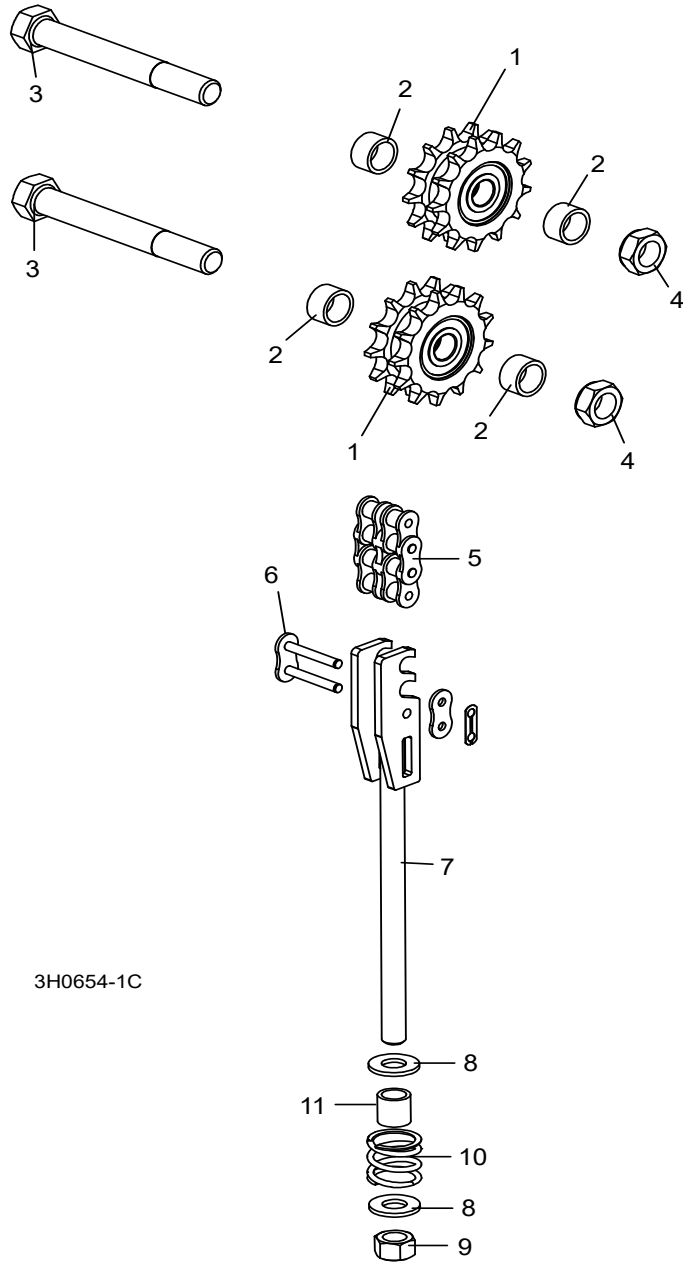

REF	PART #	QTY.
1-2	016020	1
1	016019	2
2	016018	4
3	F05009-6	2
4	F05010-96	2

5	015259	1
6	015258	2
7-11	015456	1
7	015188	1
8	F05011-2	2
9	F05010-8	1

10	016516	1
11	016515	1

5.4 Moteur De Montée

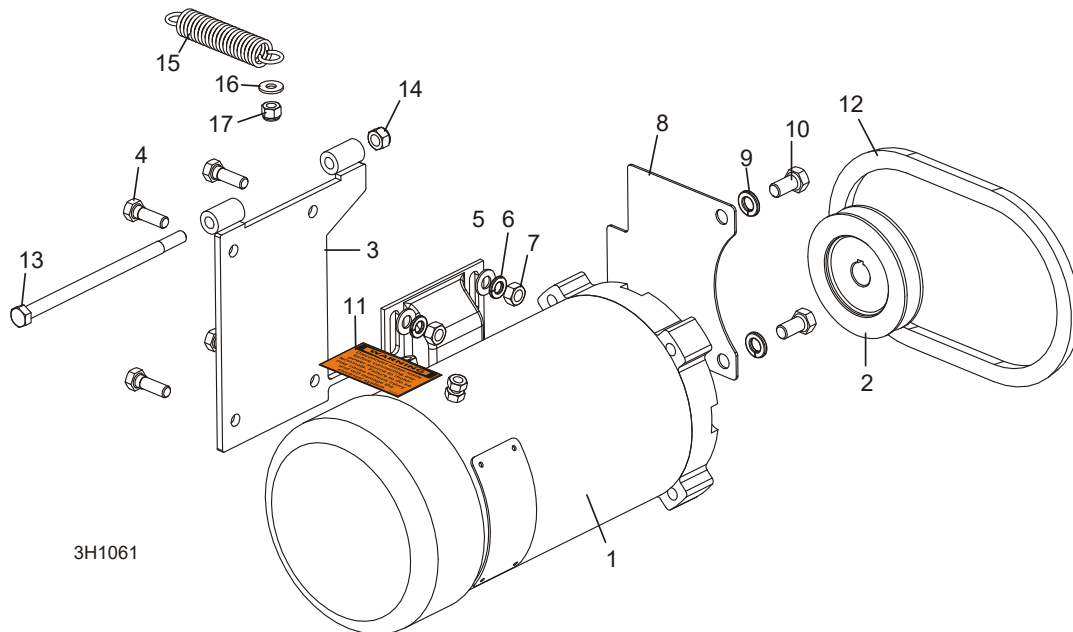

REF	PART #	QTY.
1 - 11	008779	1
1	053682	1
2	008999	1
3	015198	1
4	F05006-1	4
5	F05011-17	4
6	F05011-13	4
7	F05010-17	4
8	015016	1
9	F05011-4	2
10	F05007-27	2
11	024431	1
12	038459	1
13	F05006-73	1
14	F05010-65	1
15	015569	1
16	F05011-11	1
17	F05010-69	1

5.5 Système D'entraînement De Montée

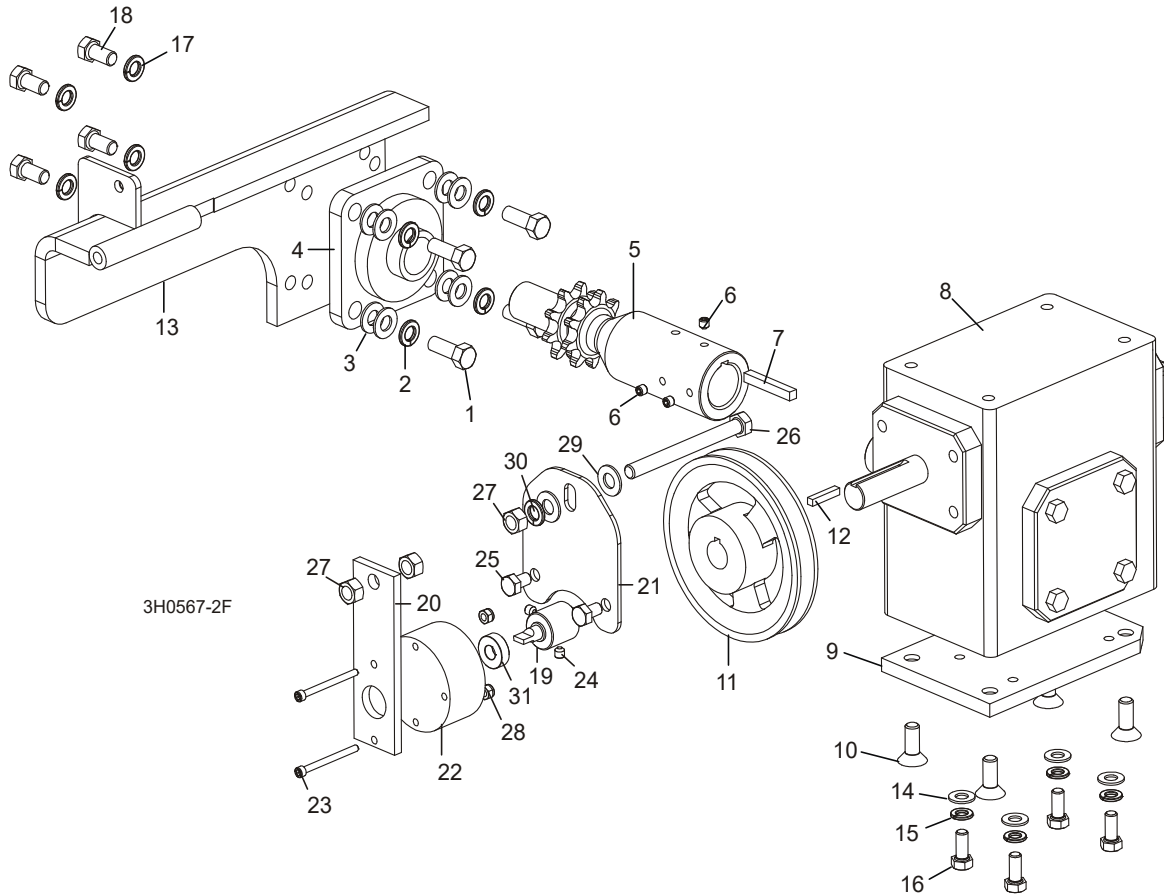

REF	PART #	QTY.
1-13	015176	1
1	F05007-7	4
2	F05011-4	4
3	F05011-3	8
4	014090	1
5-7	016094	1
5	----	1
6	F05005-105	3
7	S04124	1
8	074124	1
9	014158	1
10	F05007-64	4
11	015256	1
12	S31027	1
13	015195	1

14	F05011-17	4
15	F05011-13	4
16	F05006-102	4
17	F05011-4	4
18	F05007-27	4
19-31	065187	1
19	062511	1
20	062513	1
21	065190	1
	065907	1
22	069519	1
	F05708-26	2
23	F05004-273	2
24	F05005-131	2
25	F05006-15	2
26	F05007-92	1

27	F05010-1	3
28	F05010-169	2
29	F05011-3	2
30	F05011-4	1
31	P10688	1

PARTIE 6 SYSTÈME D'ENTRAÎNEMENT ET PALIERS

6.1 Paliers de Rail Superieur et Grattoirs

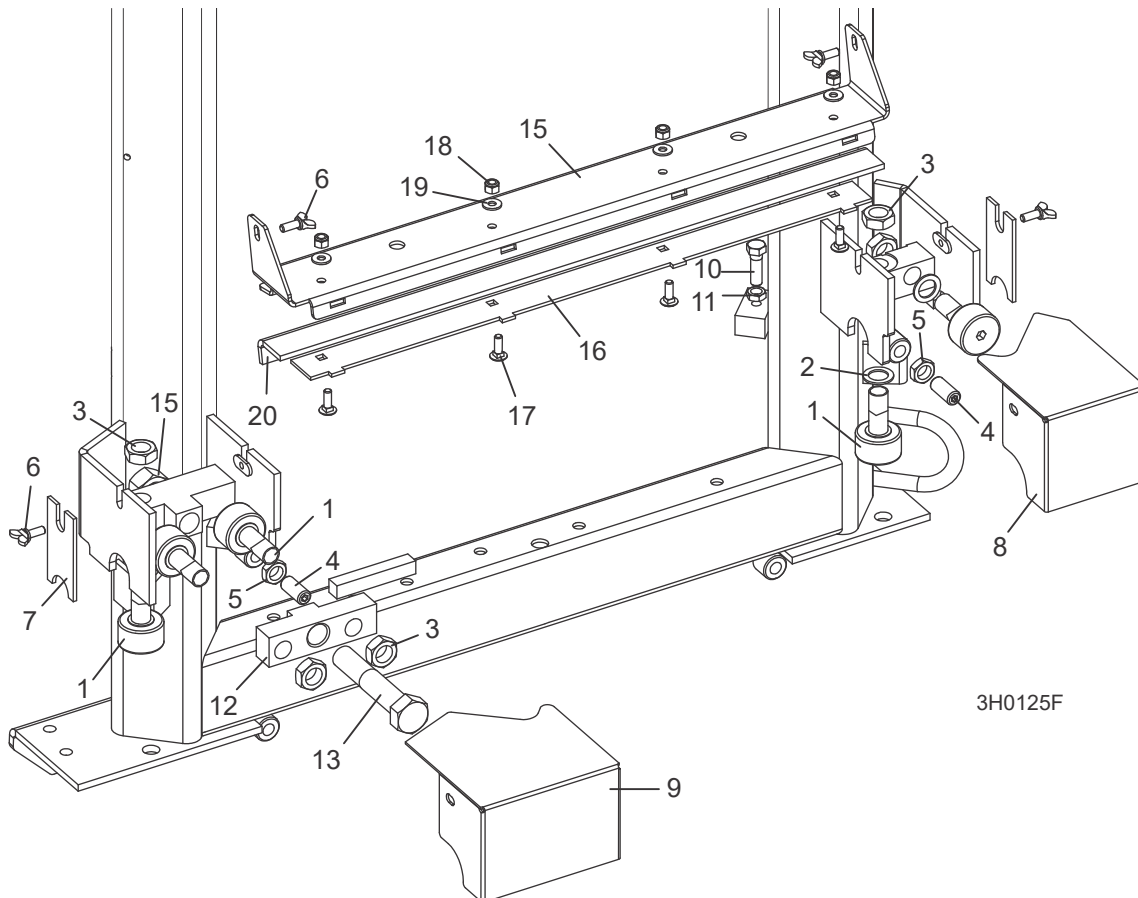

3H0125F

REF	PART #	QTY.
1	012797	5
2	016510	2
3	F05010-11	5
4	F05008-5	2
5	F05010-31	2
6	F05005-64	4
7	M04113	2
8	012999	1
9	016285	1
10	F05007-2	2
11	F05010-29	2
12	016501	1
13	F05013-3	1

14	F05010-80	1	
	110612	1	
15	110609	1	◆
16	110611	1	◆
17	F05005-113	4	
18	F05010-69	4	
19	F05011-11	4	
20	S09915	1	

6 Système D'entraînement Et Paliers

Système D'entraînement

6.2 Système D'entraînement

⚠ WARNING
 Disconnect motor leads before connecting any power source to motor terminals. Failure to do so may cause serious injury and will damage the electrical system.

Wood-Mizer
 800-525-8100 Reorder #024431

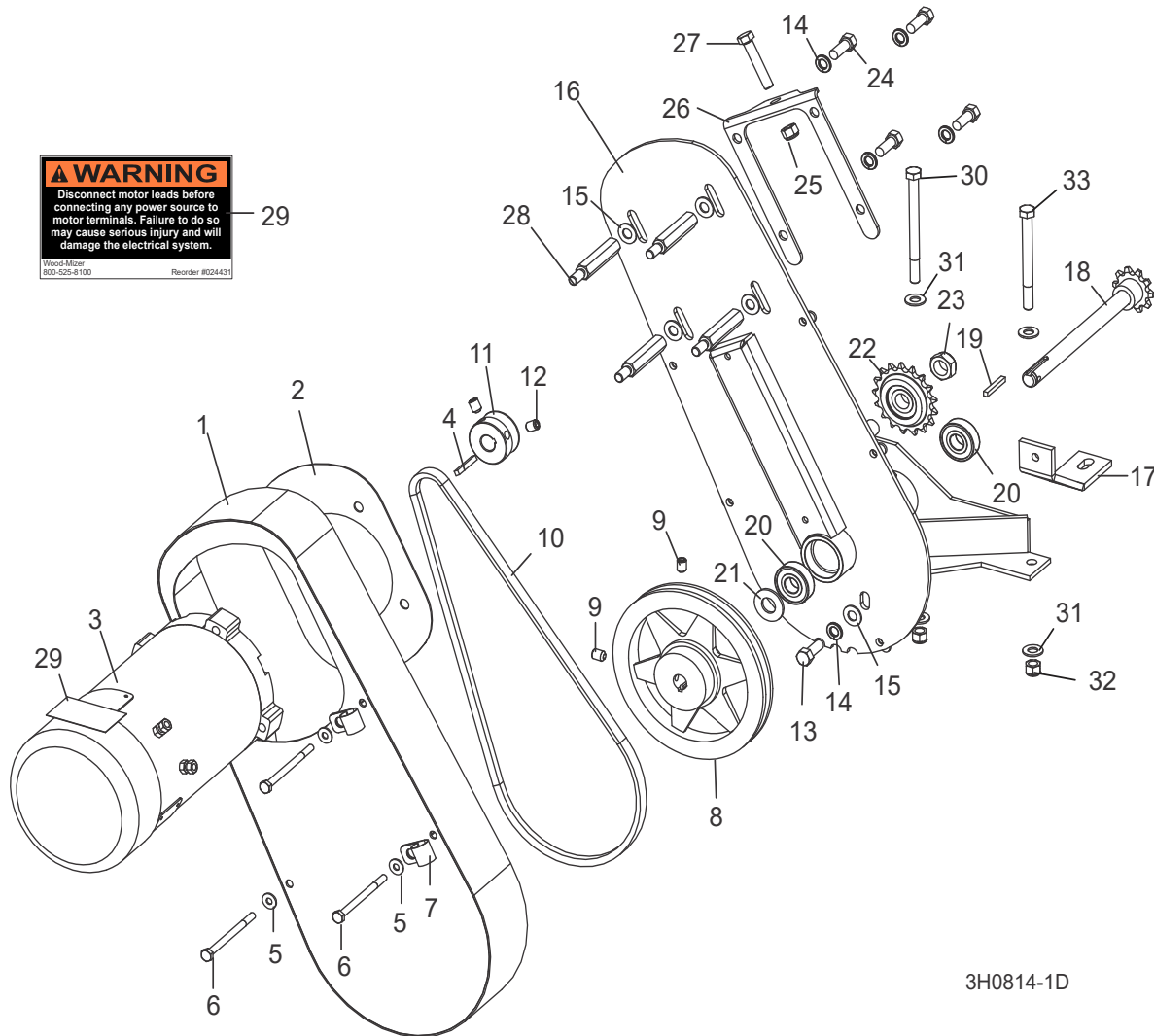

3H0814-1D

REF	PART #	QTY.
1-29	015125	1
1	015126	1
2	015133	1
3	024169	1
4	S31027	1
5	F05011-11	4
6	F05005-54	4
7	010748	2
8-9	016088	1

9	F05006-32	2
10	016083	1
11	015135	1
12	F05007-12	2
13	F05007-7	1
14	F05011-4	5
15	F05011-3	5
16	015162	1
17	015132	1
18-19	016066	1
18	----	1

19	016108	1
20	P06030-1	2
21	F05011-19	1
22	016366	1
23	F05010-96	1
24	F05007-27	4
25	F05010-10	1
26	015134	1
27	F05007-16	1
28	015136	4
29	024431-5	1

30	F05007-35	1
31	F05011-3	4
32	F05010-10	2
33	F05007-4	1

6.3 Chaîne D'entraînement Et Butoir

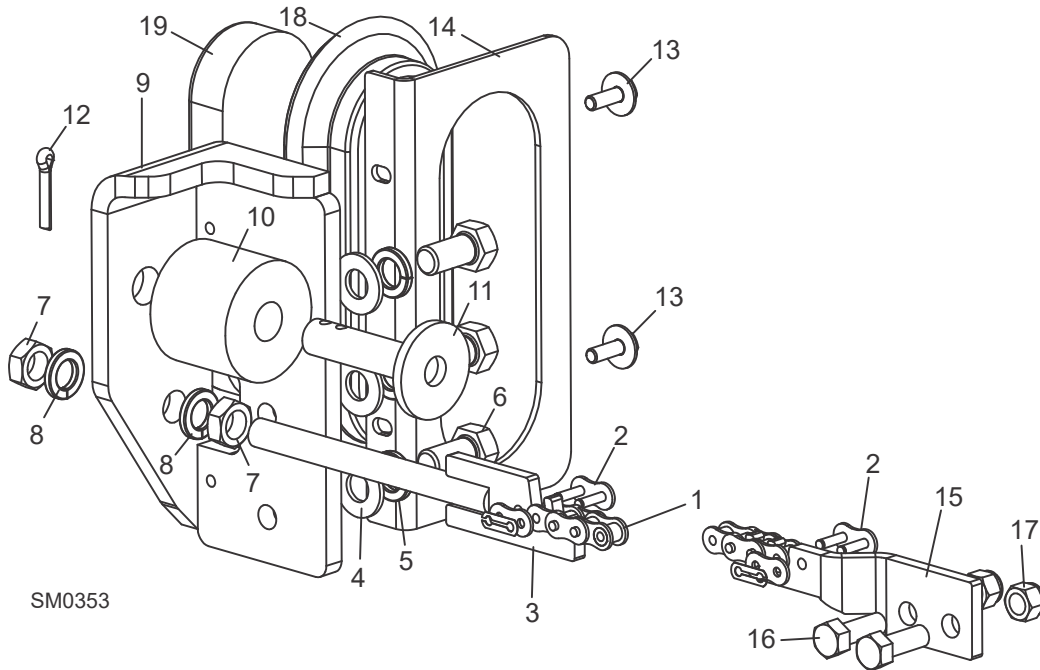

REF	PART #	QTY.
1	014744	1
	014745	1
2	P04200	2
3	015721	1
4	F05011-2	3
5	F05011-9	3
6	F05008-128	3

7	F05010-16	2
8	F05011-9	2
9	006686	1
10-12	K09630	2
10	P12165	1
11	W09293	1
12	F05012-21	1
13	F05005-134	2

14	057882	1
15	015008	1
16	F05007-7	2
17	F05010-10	2
18	006688	1
19	006391	1

6.4 Paliers De Rail Inférieur

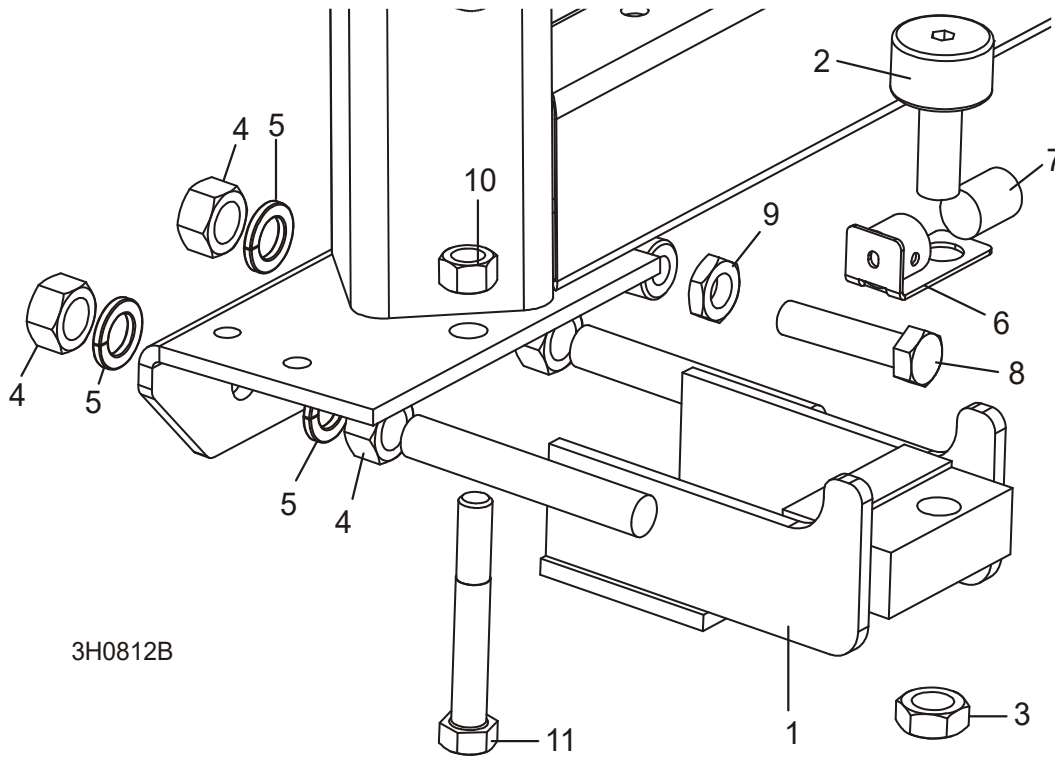

REF	PART #	QTY.
1-7	012995	2
1	----	1
2	012797	1
3	F05010-11	1
4	F05010-5	4
5	F05011-118	4
6	033374	1
7	033375	1
8	F05008-2	2
9	F05010-31	2
10	F05010-3	2
11	F05008-61	2

PARTIE 7 BÂTI DE LA SCIE

7.1 Rails Avant Et Arrière Du Banc De Grume

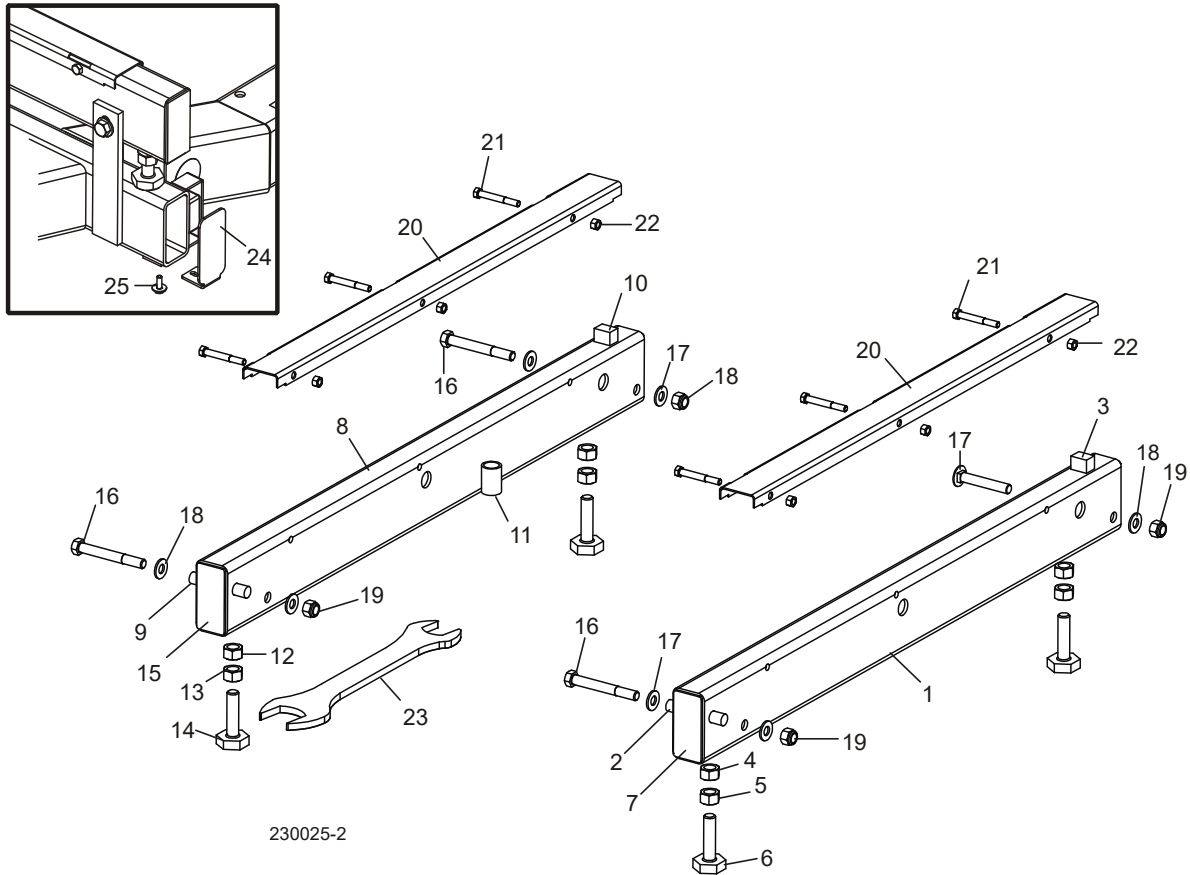

REF	PART #	QTY.
1-7	A09774	1
1	----	1
2	S04030	1
3	S09034	1
4	F05010-84	2
5	F05010-5	2
6	S13006	2
7	----	2
1-15	A09564	1
8	----	1
9	S04030	1
10	S09034	1
11	----	1

12	F05010-84	2
13	F05010-5	2
14	S13006	2
15	----	2
16	F05008-78	3
17	F05008-94	1
18	F05011-2	7
19	F05010-8	4
20	016898	2
21	F05006-10	6
22	F05010-6	6
23	015970	1
24	038843	2
25	F05005-134	2

7.2 Rail Centre-avant Du Banc De Grume

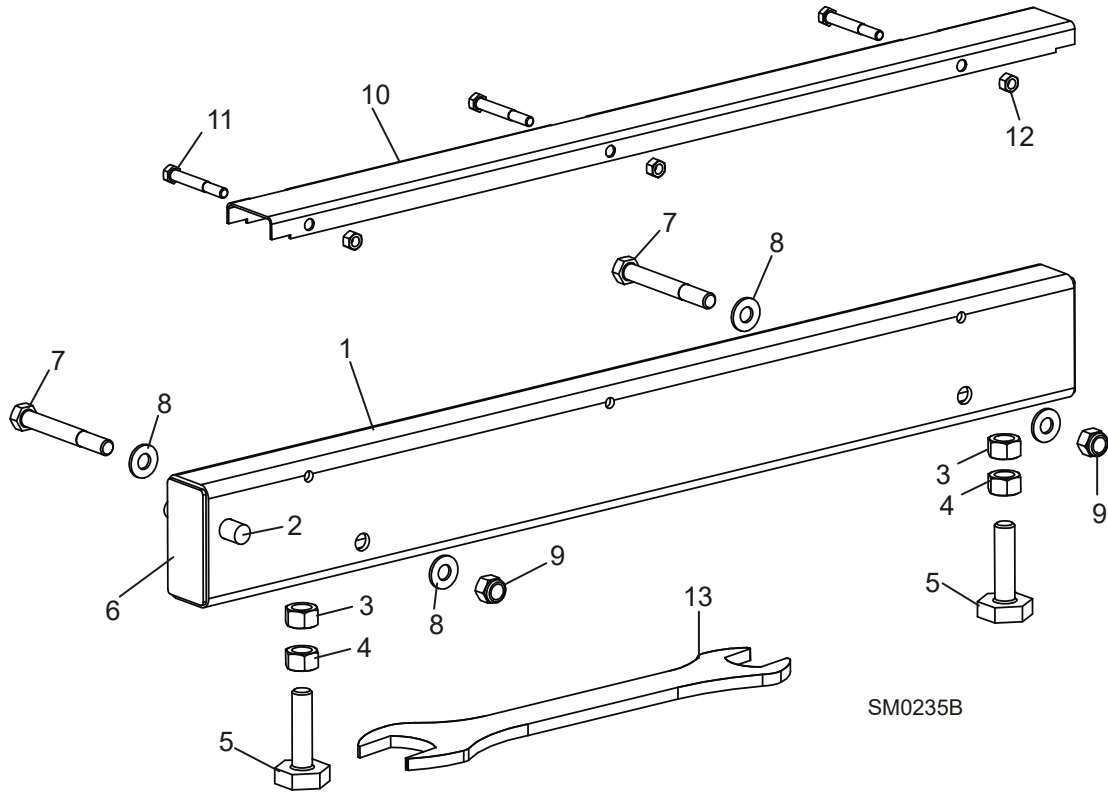

REF	PART #	QTY.
1-6	A09566	1
1	----	1
2	S04030	1
3	F05010-84	2
4	F05010-5	2
5	S13006	2
6	----	2
7	F05008-78	2
8	F05011-2	4
9	F05010-8	2
10-12	A09956	1
10	----	1
11	F05006-10	3
12	F05010-6	3
13	015970	1

7.3 Rail Centre-arrière Du Banc De Grume

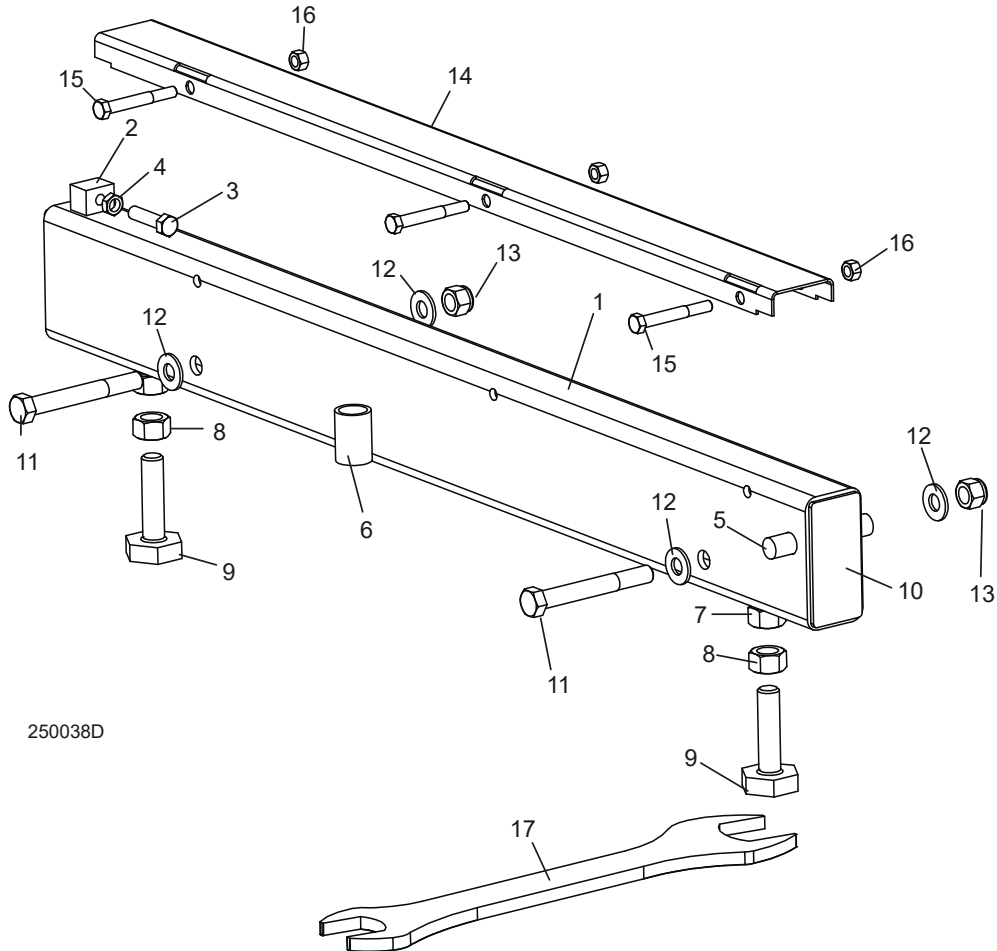

REF	PART #	QTY.
1-10	A09565	1
1	014640	1
2	014639	1
3	F05007-17	1
4	F05010-29	1
5	S04030	1
6	S09334	1
7	F05010-84	2
8	F05010-5	2
9	S13006	2
10	S04058	2
11	F05008-78	2
12	F05011-2	4

13	F05010-8	2
12-14	A09956	1
14	-----	1
15	F05006-10	3
16	F05010-6	3
17	015970	1

7.4 Appuis Fixes

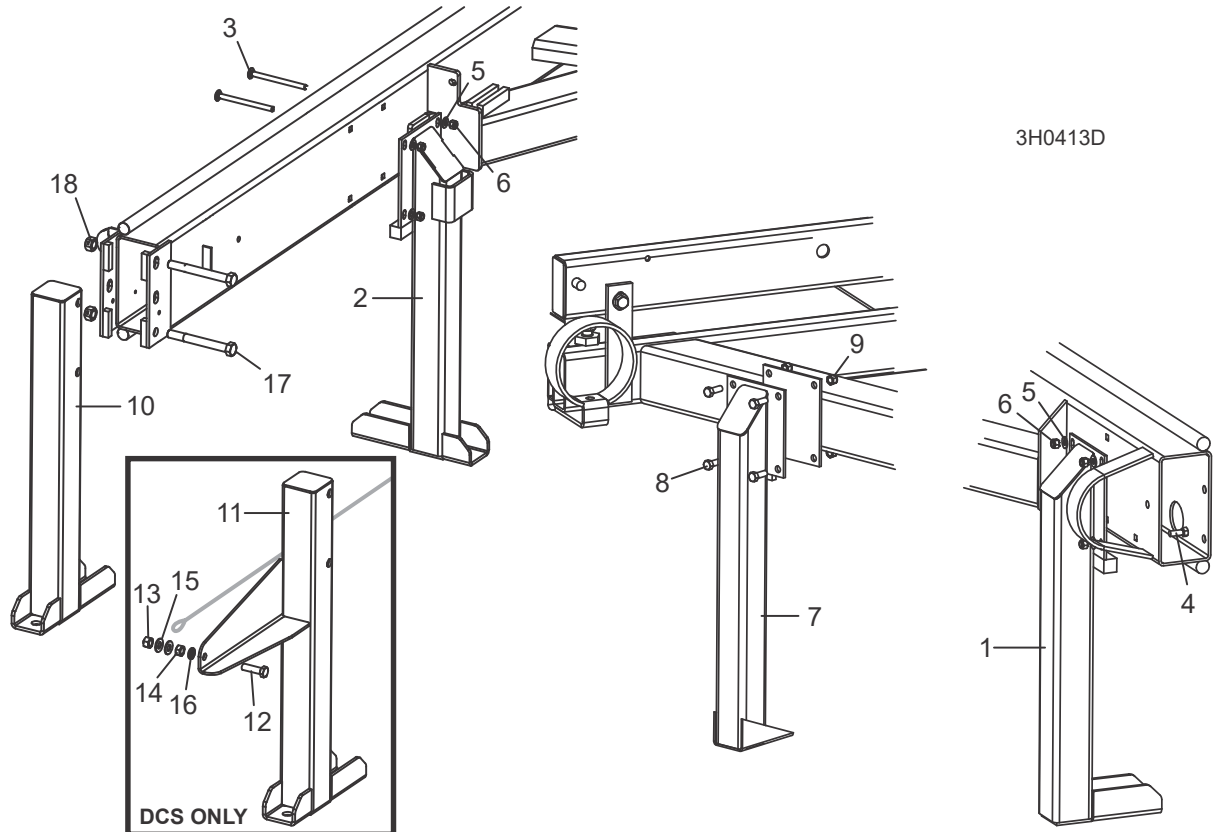

REF	PART #	QTY.
1	W09513	1/3
2	015091	1
3	F05007-113	8/12
4	F05007-2	4
5	F05011-3	8/16
6	F05010-10	8/16
7	W09515	2
8	F05007-2	8
9	F05010-10	8
10	W09517	1
11	F05009-11	2
12	F05010-4	2

7.5 Table D'éjecteur De Planches

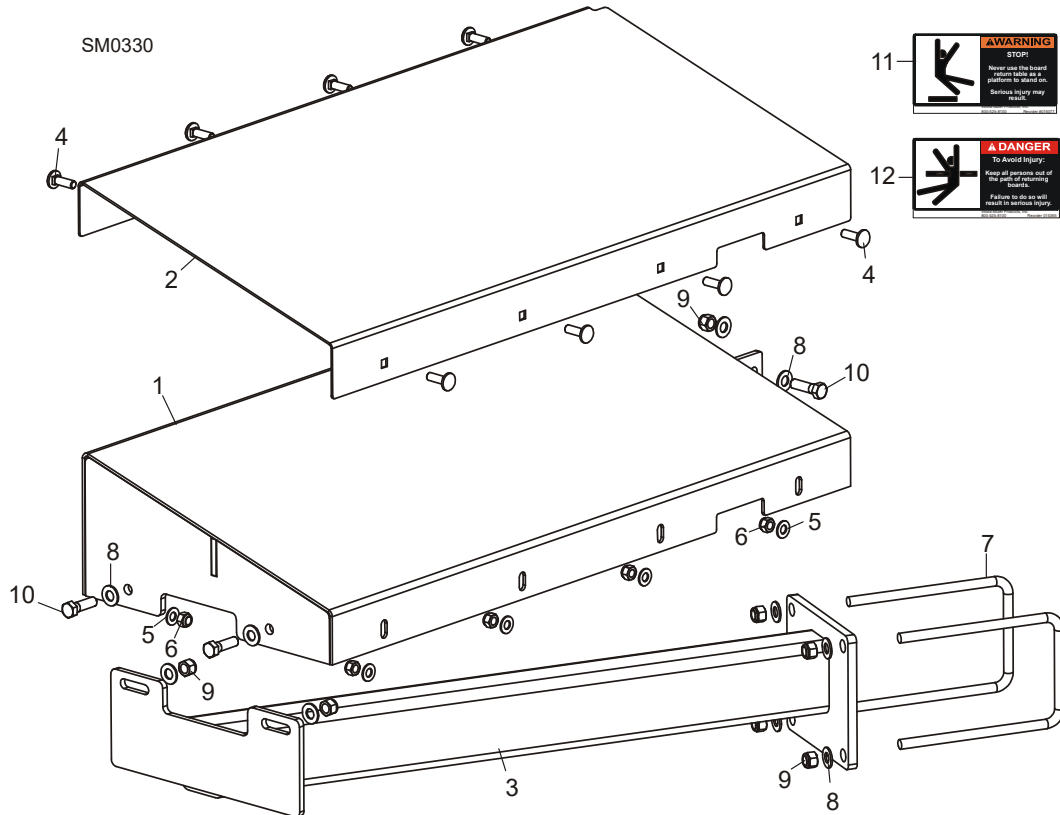

REF	PART #	QTY.
1-12	003264 ¹	1
	003270 ²	1
1	055515	1
2	003259	1
3	055533 ¹	1
	038992 ²	1
4	F05006-9	8
5	F05011-17	8
6	F05010-58	8
7	003207	2
8	F05011-3	10
9	F05010-10	7
10	F05007-123	3
11	016077-5	1
12	015365-5	1

¹ LT40

² LT30

7.6 Support De Grume Mobile

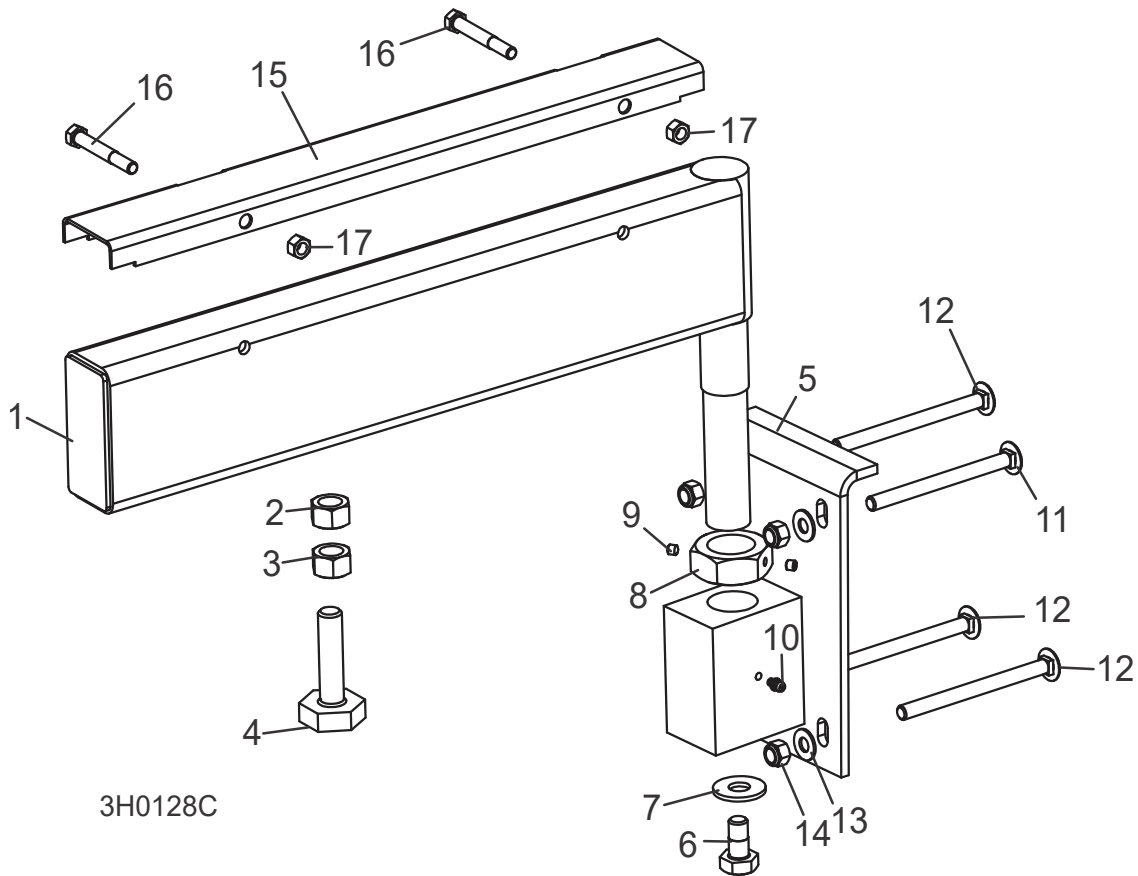

REF	PART #	QTY.
1-10	A13015 ¹	2
	012993 ²	2
1-4	-----	1
	-----	1
2	F05010-84	2
3	F05010-5	2
4	S13006	2
5	W13090	1
6	F05008-50	1
7	F05011-52	1
8	S13016	1
9	F05005-42	2
10	P04107	1

11	F05007-114	2
12	F05007-113	6
13	F05011-3	8
14	F05010-10	8
15-17	017710 ¹	2
	015926 ²	2
15	S13012 ¹	1
	012994 ²	1
16	F05006-10	2
17	F05010-6	2

¹LT40
²LT30

7.7 Cales À Billes (Non Hydrauliques)

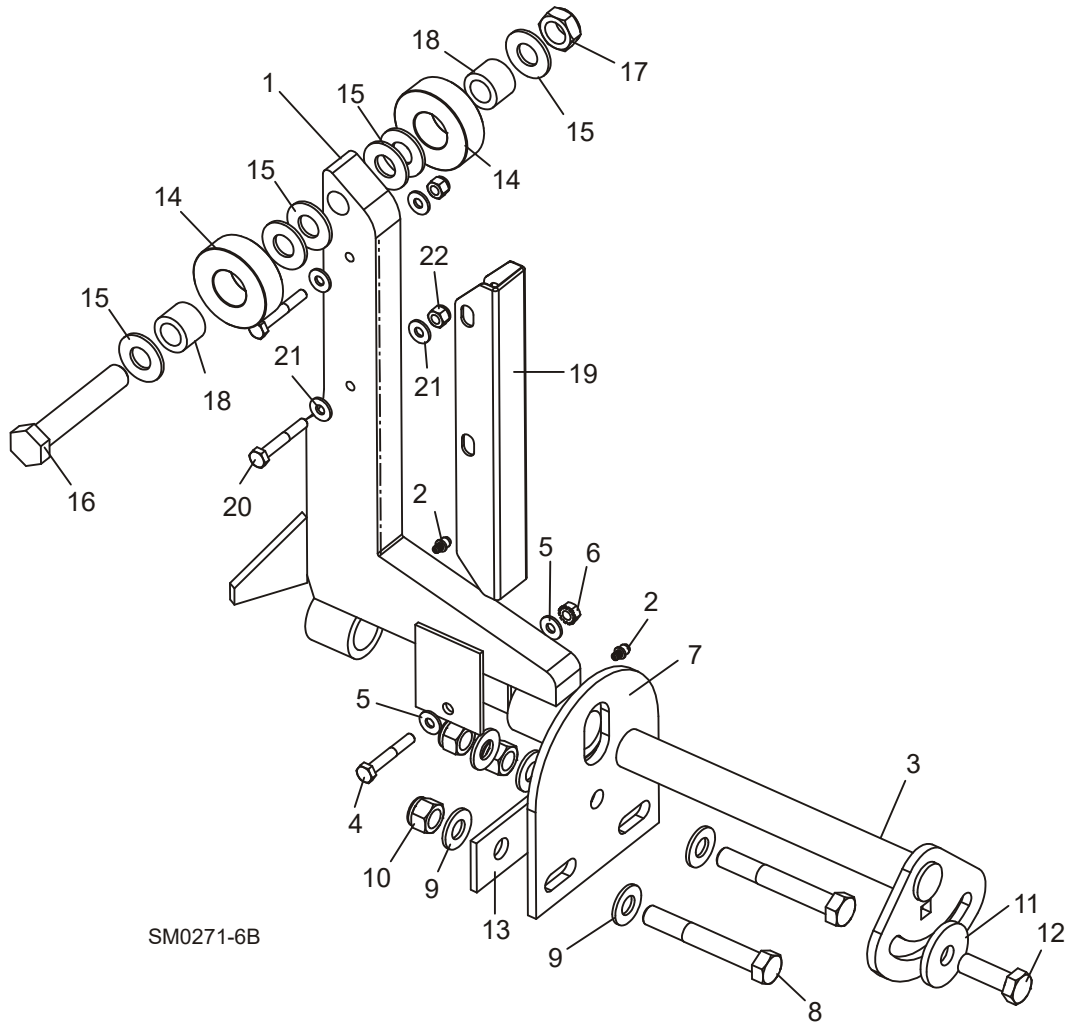

SM0271-6B

REF	PART #	QTY.
1-2	015235	4
2	P04107	2
3-13	016559	4
3	016544	1
4	F05005-4	1
5	F05011-11	2
6	F05010-9	1
7	016555	1
8	F05008-61	2
9	F05011-2	2
10	F05010-8	3

11	014632	1
12	F05008-33	1
13	016558	1
14-18	016562	4
14	016561	2
15	F05011-5	6
16	F05009-118	1
17	F05010-96	1
18	016560	2
19-22	016798	1
19	016722	4
20	F05005-4	8

21	F05011-11	16
22	F05010-69	8

7.8 Chaîne De Sécurité

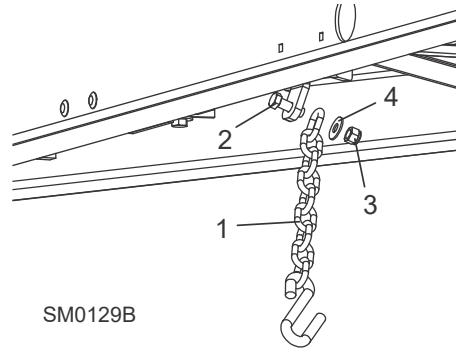

REF	PART #	QTY.
	107972	1
1	F05008-33	1
2	F05010-8	1
3	F05011-35	1

7.9 Étiquettes D'avertissement

7.10 Serre-bille

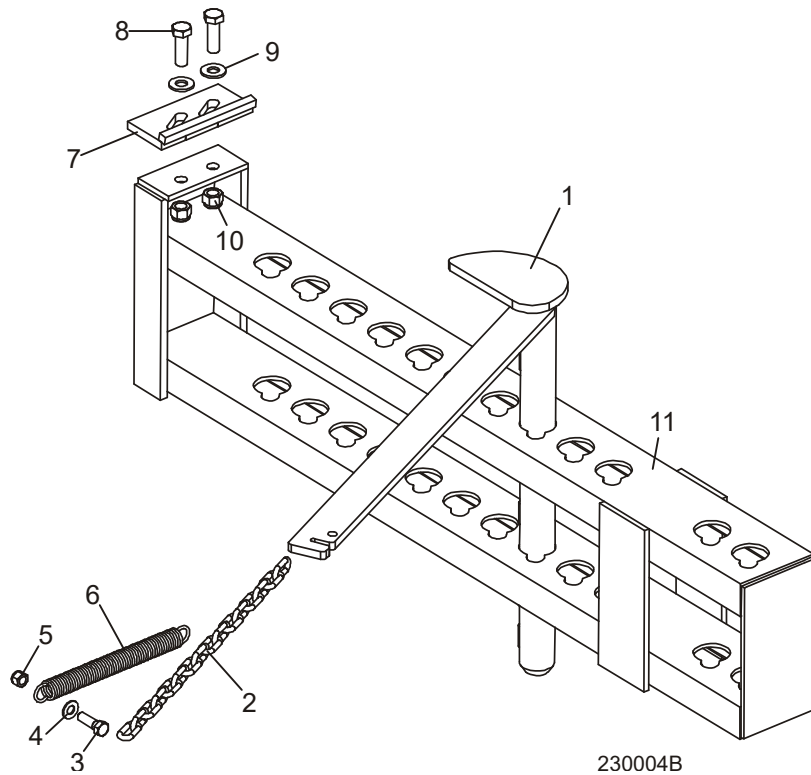

REF	PART #	QTY.
1	W09412	1
2	M04311	1
3	F05007-2	1
4	F05011-3	2
5	F05010-10	1
6	P09136	1
7	W09404	1
8	F05008-33	2
9	F05011-2	2
10	F05010-8	2
11	W09310	1

7.11 Rampes De Chargement

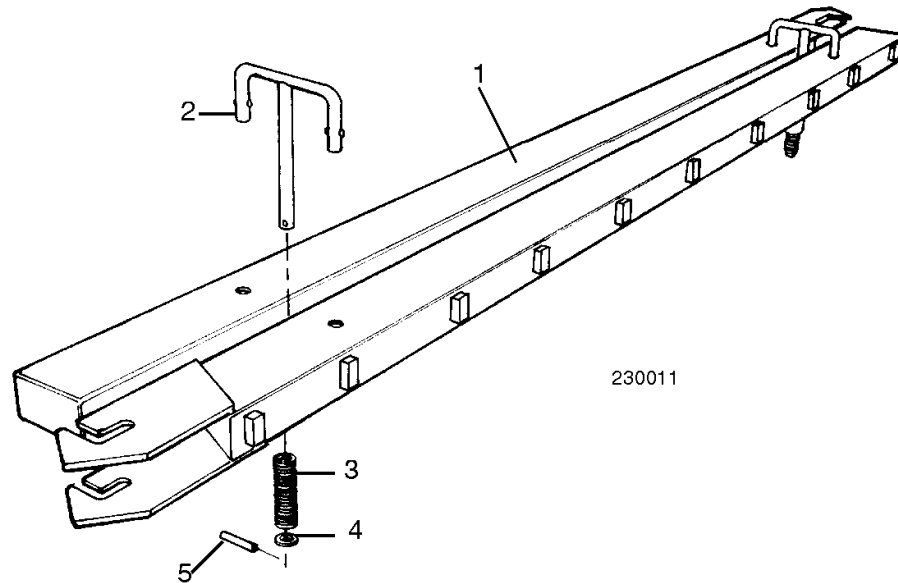

REF	PART #	QTY.
1-6	K09466	1
1	W09014	2
2-6	K09810	2
2	-----	1
3	P09335	1
4	F05011-19	1
5	F05012-11	1

7.12 Table De Planches (Optionnel)

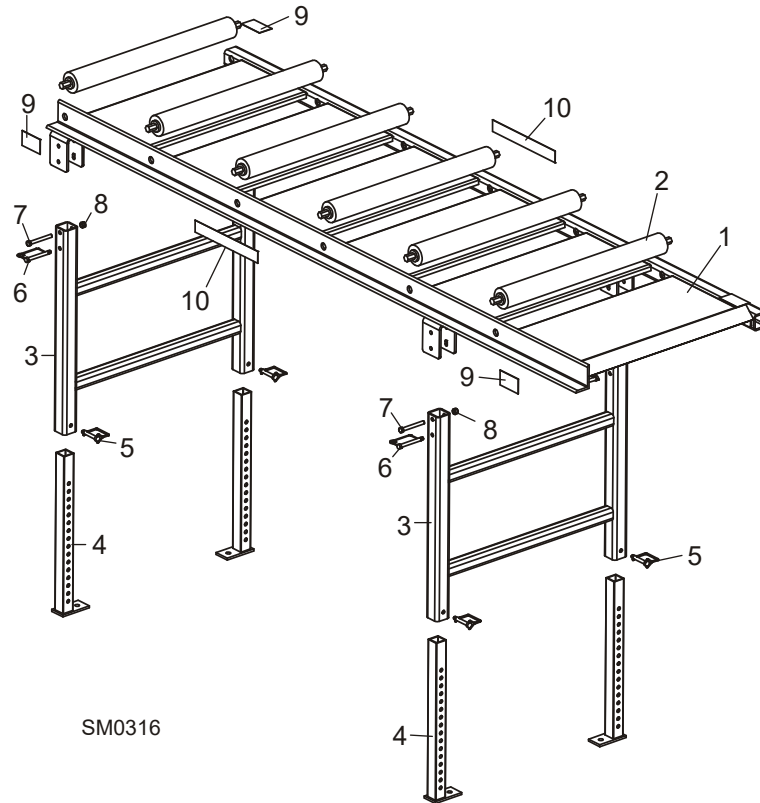

SM0316

REF	PART #	QTY.
1-10	016652	1
1	016606	1
2	038167	6
3	016609	2
4	016651	4
5	014151	4
6	016677	4
7	F05007-135	4
8	F05010-10	4
9	S12641-5	4
10	016991	2

8 Hydraulique Chargeur & Tourne-bille (Optionnel)

PARTIE 8 CHARGEUSE & TOURNE-BILLE HYDRAULIQUE (OPTIONNEL)

8.1 Boîte De Commande Des Hydrauliques

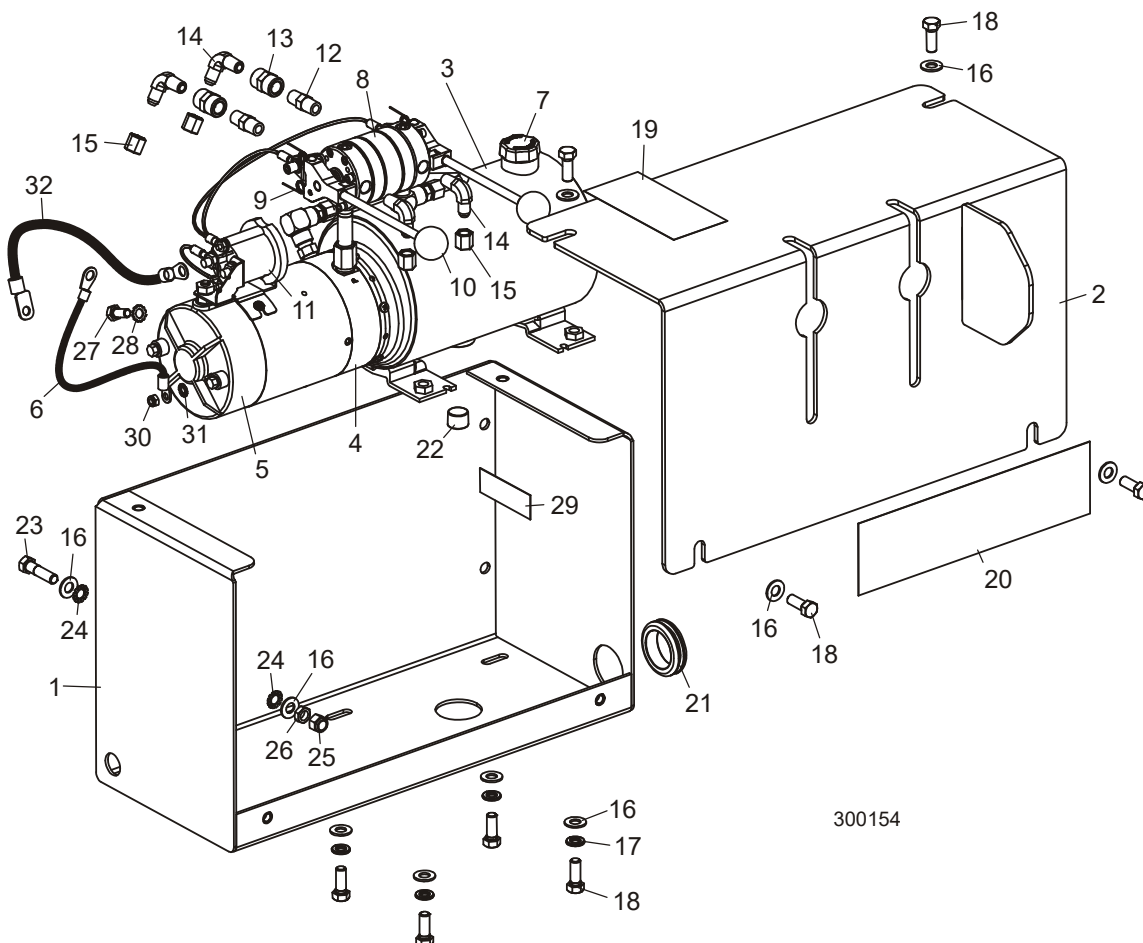

REF	PART #	QTY.
1-32	025717	1
1	025716	1
2	025714	1
3-11	025713	1
4		1
5-6	052807	1
6	052806	1
7	P09596	1
8-10		2
9	025818	4
10		2

11		1
12	P05389	2
13	P03420	2
14	P09142	4
15	016815	4
16	F05011-3	10
17	F05011-4	4
18	F05007-87	8
19	P12961	1
20	036720	1
21	043405	1
22	P26258	1

23	F05007-78	1
24	F05011-36	2
25	F05010-10	1
26	F05010-29	1
27	F05006-5	1
28	F05011-33	1
29	S12825	1
30	F05010-200	1
31	F05011-37	1
32		1

8.2 Plaque De Contact Hydraulique Et Bornes

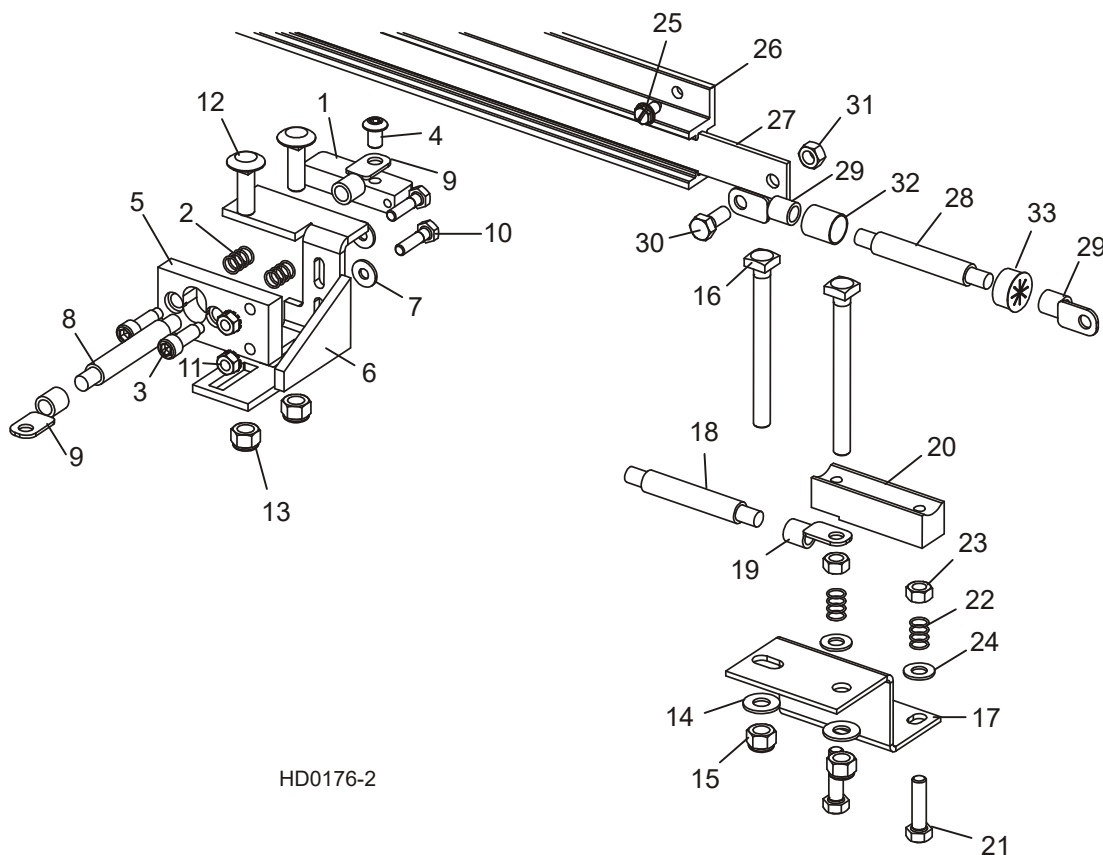

HD0176-2

REF	PART #	QTY.
1-13	036721	1
1-4	007716	1
1	015253	1
2	P10077	2
3	F05006-143	2
4	F05006-20	1
5	S10072	1
6	015324	1
7	F05011-11	2
8	R01971	Ft
9	F05092-16	2
10	F05005-38	2
11	F05010-9	2
12	F05007-11	2

13	F05010-10	2
14-24	010104	1
14	F05011-3	2
15	F05010-10	2
16	F05007-175	2
17	016792	1
18-19	036306	1
18	----	2.2 Ft
19	F05092-16	2
20-23	007717	1
20	015264	1
21	F05008-96	2
22	P10077	2
23	F05010-17	2
24	F05011-17	2

25-33	A11977	1
25	F05015-1	8
26	P11976	1
	A12043-N	1
27	----	1
28-29	052161	
28	----	Ft
29	F05092-16	2
30	F05006-45	1
31	F05010-86	1
32	R01950-5	Ft
33	P04137	1

8.3 Chargeuse Hydraulique (Optionnel)

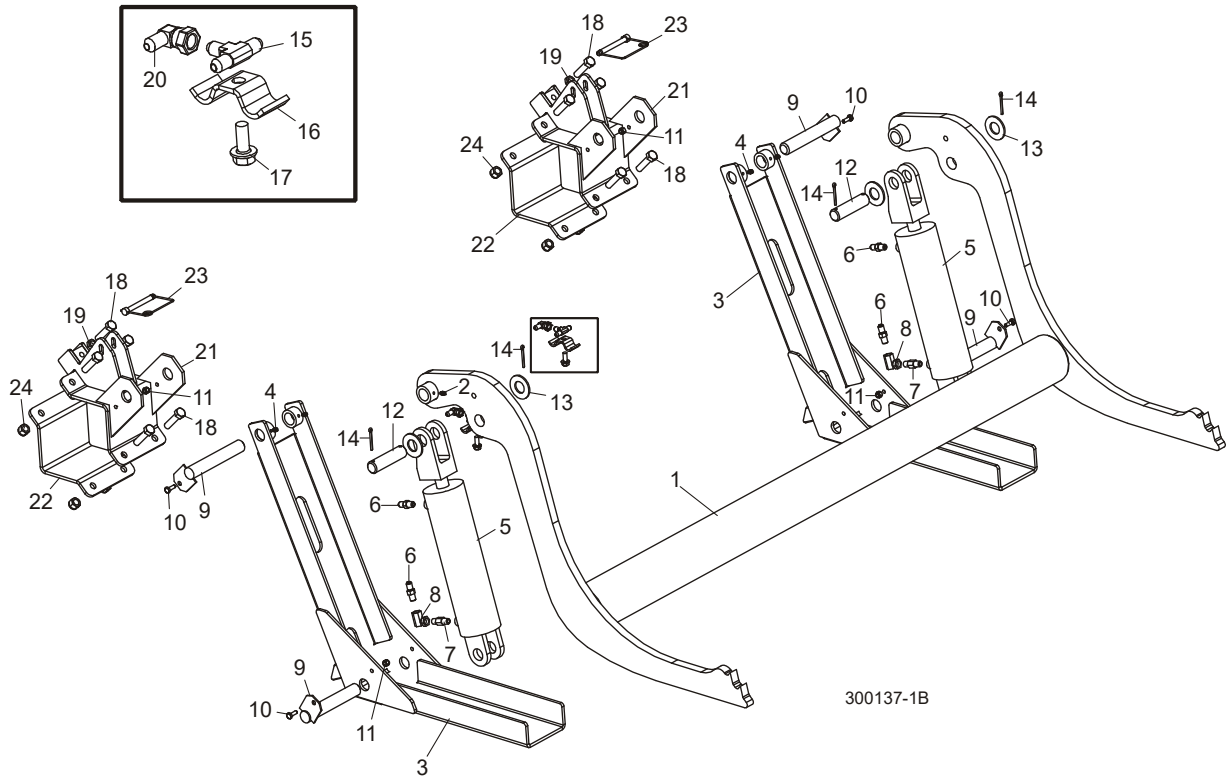

REF	PART #	QTY.	
	LTHDLA-M	1	
1	036722	1	
2	P04107	2	
3	W09444	2	
4	P04107	4	
	A09284	2	◆
5	P12847	1	
	P12956	1	
6	P09143	2	
7	P12199	1	
	015832	1	
8	015750	2	◆
	015832-255	1	
9	W09446	4	
10	F05005-1	4	
11	F05010-69	4	
12	S09251	2	

13	F05011-28	4	
14	F05012-23	4	
15	P09145	2	
16	S09245		
17	F05006-102		
18	F05008-116		
19	F05010-31	2	
20	036715	2	
21	048270	2	
22	036737	2	
23	038472	2	
24	F05010-8	8	

8.4 Tourne-bille Hydraulique (Optionnel)

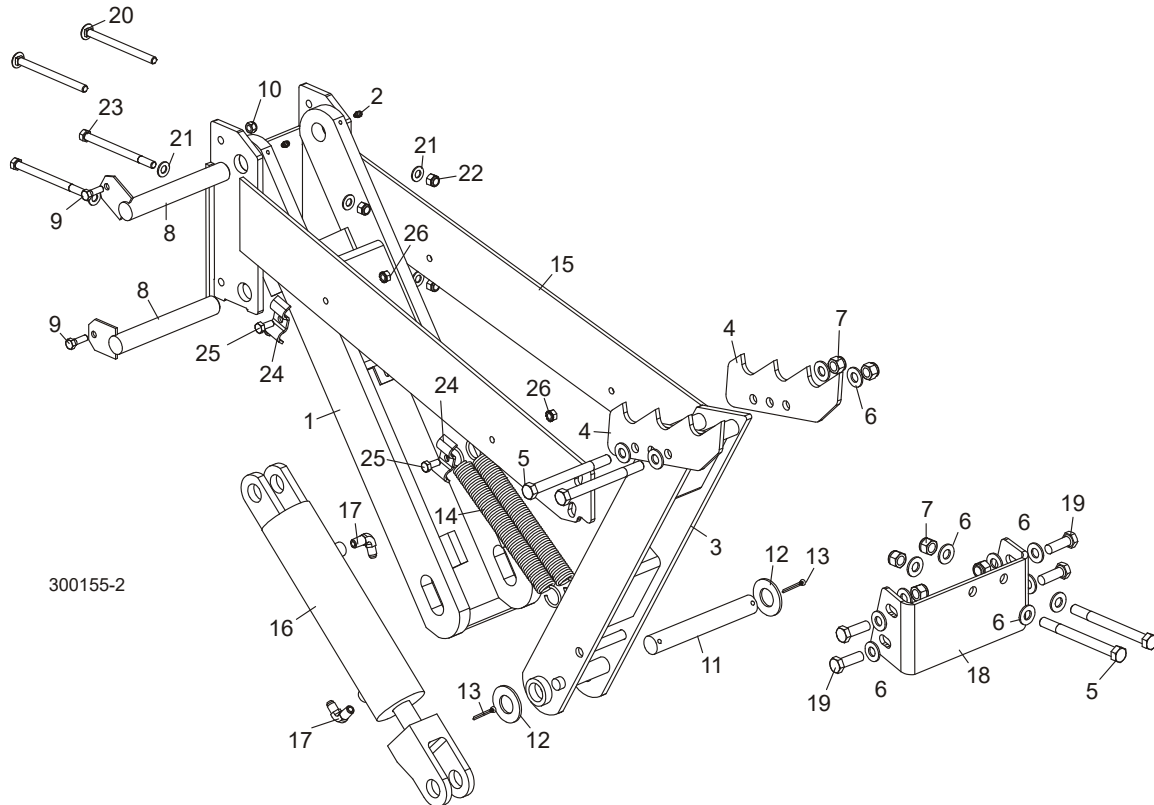

REF	PART #	QTY.
1-26	007069	1
1-2	015231	1
2	P04107	2
3	015233	1
4	014675	2
5	F05008-28	4
6	F05011-2	16
7	F05010-8	8
8	015085	2
9	F05006-1	2
10	F05010-58	2
11	S09246	1
12	F05011-28	2
13	F05012-23	2
14	015718	2
15	006999	1
16-17	A09286	1

16	P12846	1
17	P09142	2
18	007048	1
19	F05008-33	4
20	F05007-113	2
21	F05011-3	6
22	F05010-10	4
23	F05007-5	2
24	S09245	2
25	F05006-102	2
26	F05010-20	2

8 Hydraulique Chargeur & Tourne-bille (Optionnel)

Cales Hydrauliques (Optionnel)

8.5 Cales Hydrauliques (Optionnel)

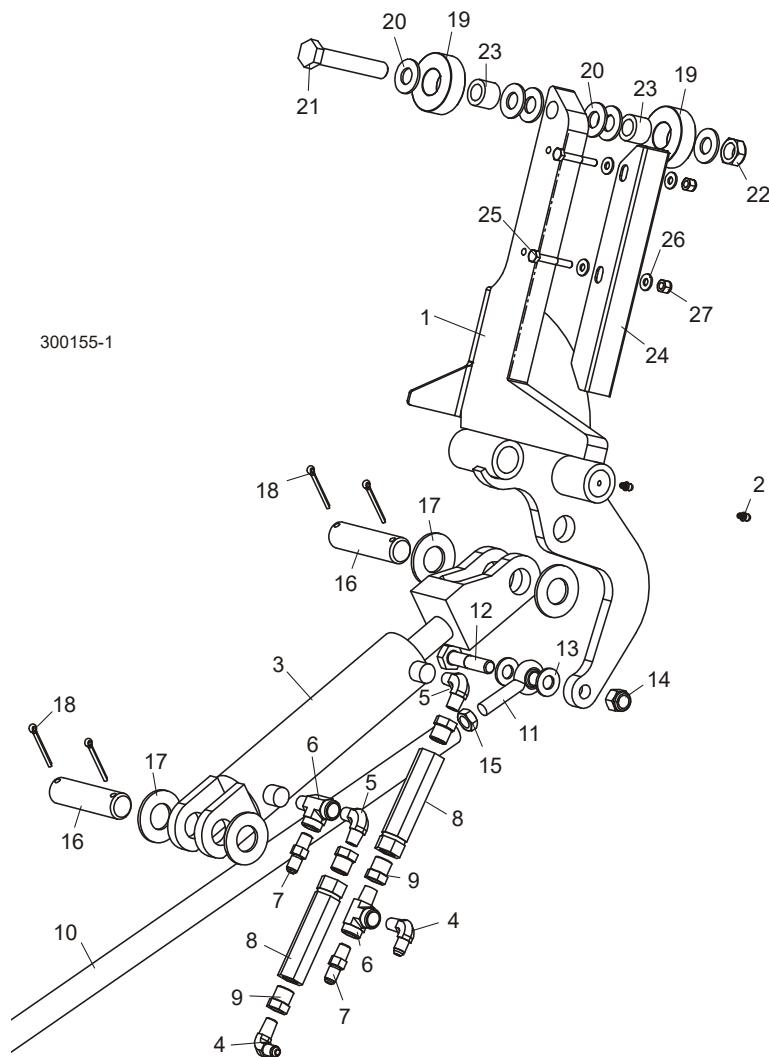

300155-1

REF	PART #	QTY.
1-2	W12339	2
2	P04107	2
3-9	A09283	1
3	P12845	1
4	P09142	2
5	P09140	2
6	P09141	2
7	P09143	2
8	015484	2
9	015490	4
10	015026	1
11	P09137	2

12	F05008-10	2
13	F05011-2	4
14	F05010-8	2
15	F05010-16	1
16	S09251	2
17	F05011-28	4
18	F05012-23	4
19-23	016562	2
19	016561	2
20	F05011-5	6
21	F05009-118	1
22	F05010-96	1
23	016560	2

24-27	016798	1
24	016722	4
25	F05005-4	8
26	F05011-11	16
27	F05010-69	8
	016798-1005	1

8.6 Chargeuse & tourne-bille hydraulique pièces

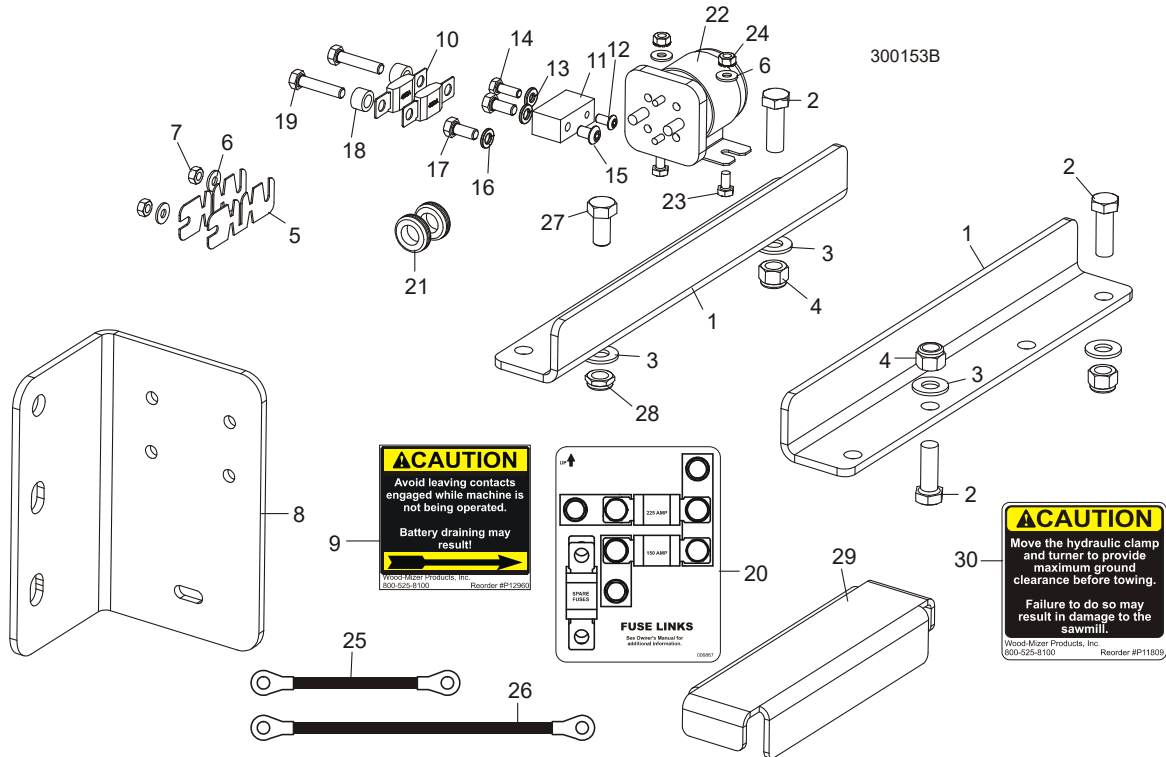

REF	PART #	QTY.
1	048269	2
2	F05008-33	3
3	F05011-2	4
4	F05010-8	3
5	P11550	2
6	F05011-11	4
7	F05010-21	2
8	048426	1
9	P12960	1
10	053339	2
11	056998	1
12	F05005-59	1
13	F05011-14	1
14	F05005-123	1
15	F05006-20	1
16	F05011-13	2
17	F05006-102	2
18	055323	2
19	F05006-2	2

20	006867	1
21	P11764	2
22	016371	1
	015470	1
	015426	1
	024451	1
23	F05005-15	2
24	F05010-9	2
25	036305	1
26	036307	1
27	F05008-128	1
28	F05010-127	1
29	025745	1
30	P11809	1