

Wood-Mizer[®] Sawmill

Safety, Setup, Operation
& Maintenance Manual

LT70 Super Hydraulic

rev. A6.01

Safety is our #1 concern!

October 2014

Form #2062



WARNING! Read and understand this manual before using this machine.

California

Proposition 65 Warning



WARNING: Breathing gas/diesel engine exhaust exposes you to chemicals known to the State of California to cause cancer and birth defects or other reproductive harm.

Always start and operate the engine in a well-ventilated area.
If in an enclosed area, vent the exhaust to the outside.
Do not modify or tamper with the exhaust system.
Do not idle the engine except as necessary.

For more information go to www.P65warnings.ca.gov.



WARNING: Drilling, sawing, sanding or machining wood products can expose you to wood dust, a substance known to the State of California to cause cancer. Avoid inhaling wood dust or use a dust mask or other safeguards for personal protection.

For more information go to www.P65Warnings.ca.gov/wood.

Active Patents assigned to Wood-Mizer, LLC

Wood-Mizer, LLC has received patents that protect our inventions which are a result of a dedication to research, innovation, development, and design. Learn more at: woodmizer.com/patents

©2023 Wood-Mizer LLC

Printed in the United States of America, all rights reserved. No part of this manual may be reproduced in any form by any photographic, electronic, mechanical or other means or used in any information storage and retrieval system without written permission from

Wood-Mizer, LLC
8180 West 10th Street
Indianapolis, Indiana 46214

SECTION 1 INTRODUCTION

1.1 About This Manual 1-1
 1.2 Getting Service..... 1-1
 1.3 Specifications 1-1

SECTION 2 GENERAL SAFETY

2.1 Safety Symbols 2-1
 2.2 Safety Instructions..... 2-1
 2.3 Electrical Lockout Procedures 2-3

SECTION 3 SAWMILL SETUP

3.1 Sawmill Setup 3-1
 3.2 Installing The Blade 3-3
 3.3 Tensioning The Blade 3-5
 3.4 Tracking The Blade..... 3-5
 3.5 Starting The Engine or Motor 3-6
 3.6 3-6
 3.7 Board Return 3-6
 3.8 Debarker Setup..... 3-7

SECTION 4 SAWMILL OPERATION

4.1 Hydraulic Control Operation 4-1
 4.2 Loading, Turning And Clamping Logs..... 4-3
 4.3 Up/Down Operation..... 4-4
 4.4 Blade Guide Arm Operation 4-4
 4.5 Autoclutch Operation..... 4-5
 4.6 Debarker Operation..... 4-5
 4.7 Power Feed Operation..... 4-6
 4.8 Control Operation 4-8
 Display Overview 4-8
 Configuration 4-9
 Language 4-9
 Unit of Measure..... 4-9
 Engine Type 4-10
 Head Position Calibration 4-10
 Auto Mode Settings..... 4-12
 Hydraulic Settings..... 4-12
 Diagnostics 4-13
 Joystick Configuration 4-13
 4.9 Auto-Setting Features 4-15
 Mode Selection 4-15
 Using Auto-Down Mode..... 4-16
 Using Auto-Up Mode 4-17
 Using Pattern Mode 4-17
 Auto-Mode Settings Menu 4-17
 Joystick Auto-Mode Operation..... 4-20
 4.10 Cutting The Log..... 4-20
 4.11 Edging 4-21
 4.12 Optional Cutting Procedure 4-21
 4.13 Water Lube Operation..... 4-22

4.14 Preparing The Sawmill For Towing4-23

SECTION 5 MAINTENANCE

5.1 *Wear Life* 5-1

5.2 Blade Guides5-2

5.3 Sawdust Removal5-3

5.4 Carriage Track, Wiper & Scraper.....5-3

5.5 Vertical Mast Rails5-4

5.6 Miscellaneous5-4

5.7 Blade Tensioner.....5-5

5.8 Blade Wheel Belts5-5

5.9 Drive Belt Adjustment.....5-5

Adjust belt tension..... 5-6

5.10 Brake Adjustment.....5-6

5.11 Autoclutch Belt.....5-7

5.12 Hydraulic System5-7

5.13 Power Feed5-8

5.14 Charging the Battery.....5-8

5.155-9

5.16 Maintenance Chart.....5-10

5.16 MAINTENANCE LOG 5-10

SECTION 6 TROUBLESHOOTING GUIDE

6.1 Sawing Problems.....6-1

6.2 Engine/Motor and Drive Pulleys Alignment.....6-2

6.3 System Diagnosis6-2

SECTION 7 SAWMILL ALIGNMENT

7.1 Routine Alignment Procedure..... 7-1

- Blade Installation*..... 7-1
- Saw Head Tilt*..... 7-1
- Blade Guide Arm Alignment* 7-2
- Blade Guide Vertical Tilt Alignment*..... 7-4
- Blade Guide Horizontal Tilt Adjustment*..... 7-5
- Blade Guide Flange Spacing*..... 7-5
- Manual Side Support Alignment* 7-6
- Hydraulic Side Support Alignment*..... 7-7

7.2 Complete Alignment Procedure..... 7-8

- Frame Setup* 7-8
- Blade Installation*..... 7-8
- Blade Wheel Alignment* 7-8
- Track Roller Adjustment*..... 7-11
- Bed Rail Adjustment*..... 7-12
- Blade Guide Installation* 7-13
- Blade Guide Arm Alignment* 7-14
- Blade Guide Deflection* 7-15
- Blade Guide Vertical Tilt Alignment*..... 7-16
- Blade Guide Horizontal Tilt Adjustment*..... 7-16
- Blade Guide Flange Spacing*..... 7-17
- Blade Guide Level*..... 7-18
- Blade Block Adjustment* 7-19
- Manual Side Support Alignment* 7-19
- Hydraulic Side Support Alignment*..... 7-20
- Clamp Stop/Stop Bolt Adjustment*..... 7-20
- Saw Head Tilt*..... 7-20

Wood-Mizer® LLC Limited Product Warranty



Wood-Mizer LLC ("Warrantor"), an Indiana corporation with its principal place of business at 8180 West Tenth Street, Indianapolis, IN 46214-2400 USA, warrants to the purchaser ("Purchaser") that for the time periods specifically stated herein and subject to the terms, conditions and limitations stated herein, the equipment manufactured by the Warrantor will be free from defects in material and workmanship attributable to Warrantor so long as, during the warranty periods stated herein, the equipment is installed, operated and maintained in accordance with the instructions provided by Warrantor.

PRODUCT	MODEL CLASS	LENGTH OF WARRANTY		EFFECTIVE DATE
		USA & CANADA	NON USA & CANADA	
Portable Sawmills, Resaws, Edgers	LT, LX, HR, EG	Two years	One year	Date of purchase
Portable Sawmills with Chassis	LT28, LT35, LT40, LT50, LT70, LX450	Two years, excluding the chassis, which chassis shall have a five year warranty	One year	
Industrial Sawmills, Resaws, Edgers	WM, HR, EG, TVS, SVS	One year	One year	Date of purchase or date of installation / training (if applicable), whichever occurs first, not to exceed 6 months from date of purchase
TITAN Industrial	WB, TV, HR, EG, EA, MR	One year	One year	
Material Handling	TWC, IC, TD, LD, GC, CR, CB, CC	One year	One year	
Blade Maintenance Equipment	BMS, BMT, BMST	One year	One year	Date of purchase
Options and Accessories	Various	One year*	One year*	
Moulders, Extractors	MP, MD	Two years	One year	
Kilns	KS, KD	One year	One year	
Slab Flattener	MB	Two years	One year	
Pallet Equipment	PD, PC	One year	One year	
Log Splitters	FS	One year	One year	
Replacement Parts	Various	90 days	90 days	

* Warranty on Options will match the warranty on the primary equipment when purchased on same invoice.

Exclusions from 90 Day, Limited One Year and Two Year Warranty

Warrantor shall have no responsibility under this warranty for any wear components, including, but not limited to: belts, blade guides, blades, electric motor brushes, drum switches, filters, fuses, hoses, bearings (excluding cylindrical drive bearings), bushings, cable carriers, and spark plugs. All wear components are furnished "as is", without any warranty from Warrantor. This limited warranty does not cover any defects caused by misuse, negligence, alterations, damage due to overload, abnormal conditions, excessive operation, accident, or lack of performance of normal maintenance services.

Several components which are used in the manufacture of the equipment but not manufactured by Warrantor such as cant hooks, power plants, laser sights, batteries, tires, and trailer axles have warranties provided by the original equipment manufacturer (written copies available upon request). Warrantor does not separately warrant such items. Components or equipment manufactured by third parties are not covered by this warranty. Warrantor, however, will provide reasonable assistance to the Purchaser to make claims against any warranties applicable to such component parts as provided by such original equipment manufacturers. Components or equipment manufactured by third parties are not covered by this Warranty.

Five Year Limited Chassis Warranty

The limited five year chassis warranty described above, DOES NOT extend to (a) any damage stemming from accident, improper towing, overload, abuse, misuse, abnormal conditions, negligence, excessive operation, or lack of maintenance, (b) rust caused by exposure to corrosive atmospheric conditions, or (c) the sawmill head, carriage, axle, brakes, or any hydraulic or electrical components attached to the chassis.

Warrantor's Obligations as To Defects

In the event that the equipment fails to perform due to defective materials or workmanship attributable to Warrantor under normal use and service within the established warranty period, Purchaser's sole and exclusive remedy and Warrantor's sole liability shall be to replace or repair, in Warrantor's sole and subjective discretion, any defective part at Warrantor's principal place of business without cost to the Purchaser if such defect exists. The determination of whether a product is defective shall be made by Warrantor in Warrantor's sole and subjective discretion. The Purchaser must notify Warrantor prior to shipping any defective part. Warrantor, at its sole discretion, may cover expenses incurred in shipping the defective part to Warrantor for evaluation; provided, however, that Warrantor will not be responsible for labor, travel time, mileage, removal, installation or incidental or consequential damages. However, any part in excess of 140 pounds must be returned by the Purchaser, to the Warrantor's nearest authorized facility at the Purchaser's expense, if return is requested by Warrantor. Warrantor shall have a reasonable time within which to replace or repair the defective part. If Warrantor determines that the product is not defective under the terms of this warranty in Warrantor's sole and subjective discretion, then Purchaser shall be responsible for any expenses incurred by Warrantor in returning the equipment to the Purchaser.

Limitations and Disclaimers of Other Warranties

EXCEPT FOR THE EXPRESS WARRANTY PROVISIONS STATED ABOVE, WARRANTOR DISCLAIMS ALL WARRANTIES, EXPRESS AND/OR IMPLIED, INCLUDING WITHOUT LIMITATION, THE IMPLIED WARRANTIES OF MERCHANTABILITY, AND FITNESS FOR A PARTICULAR PURPOSE, NON-INFRINGEMENT AND TITLE. No representation or other affirmation of fact by representatives of Warrantor, whether verbal or in writing, including photographs, brochures, samples, models, or other sales aids, shall constitute a warranty or other basis for any legal action against Warrantor. There are no other representations, promises, agreements, covenants, warranties, guarantees, stipulations or conditions, express or implied, by Warrantor except as expressly set forth herein. THE ORIGINAL PURCHASER AND ANY INTENDED USER OR BENEFICIARY OF THIS EQUIPMENT, SHALL NOT BE ENTITLED TO RECOVER ANY INDIRECT, SPECIAL, PUNITIVE, EXEMPLARY, CONSEQUENTIAL, SPECIAL, OR INCIDENTAL DAMAGES OR LOSSES, INCLUDING BUT NOT LIMITED TO, DAMAGES OF LOST PRODUCTION, LOST REVENUE, LOST PRODUCT, LOST PROFITS, LOST BUSINESS, LOSS OF USE, LOSS OF GOODWILL, OR BUSINESS INTERRUPTION, FROM WARRANTOR FOR ANY REASON WHATSOEVER INCLUDING WITHOUT LIMITATION WARRANTY OR DEFECT IN THE PRODUCT REGARDLESS OF THE SOLE, JOINT AND/OR CONCURRENT NEGLIGENCE, BREACH OF CONTRACT, BREACH OF WARRANTY, STRICT LIABILITY IN TORT OR STATUTORY CLAIMS OR OTHER LEGAL FAULT OR RESPONSIBILITY OF EITHER WARRANTOR OR PURCHASER OR ITS EMPLOYEES OR AGENTS. Warrantor does not warrant that its equipment meets or complies with the requirements of any particular safety code or governmental requirements.

Defective items replaced under the terms of this warranty become the property of Warrantor.

Design Changes

Warrantor reserves the right to change the design of its products from time to time without notice and without obligation to make corresponding changes in or to its products previously manufactured.

Rights of Purchasers

The validity and effect of this limited warranty as well as its interpretation, operation and effect, shall be determined exclusively by the principles of law and equity of the State of Indiana, USA. This limited warranty gives Purchaser specific legal rights. Purchaser may also have other rights, which may vary from state to state. Some states may not allow limitations as to the duration of implied warranties or to the exclusion or limitation of incidental or consequential damages, so some of the limitations and exclusions detailed set forth above may not apply. In the event that any one or more of the provisions of this warranty shall be or become invalid, illegal or unenforceable in any respect, the validity, legality and enforceability of the remaining provisions of this warranty shall not be affected thereby.

Interpretations

This Warranty constitutes the entire warranty agreement between Warrantor and Purchaser and supersedes any prior understandings or agreements pertaining to the same subject matter. This warranty cannot be amended except in writing which refers to this warranty which is signed by both Warrantor and Purchaser.

SECTION 1 INTRODUCTION

1.1 About This Manual

This manual replaces any previous information received on your Wood-Mizer® equipment.

The information and instructions in this manual do not amend or extend the limited warranties for the equipment given at the time of purchase.

1.2 Getting Service

For contact information, sales, service, parts, and additional manuals, sign into your account on <https://woodmizer.com>, or call inside the USA: 1-800-553-0182 or from outside the USA: 317-271-1542

1.3 Specifications

Equipment specification are included in the Online Manuals, which are found at <https://apps.woodmizer.com/Manuals/Manuals.aspx?parent=0>.

SECTION 2 GENERAL SAFETY

2.1 Safety Symbols

The following symbols and signal words call your attention to instructions concerning your personal safety. Be sure to observe and follow these instructions.

 **DANGER!** indicates an imminently hazardous situation which, if not avoided, will result in serious injury or death.

 **WARNING!** suggests a potentially hazardous situation which, if not avoided, could result in serious injury or death.

 **CAUTION!** refers to potentially hazardous situations which, if not avoided, may result in minor or moderate injury or damage to equipment.

NOTICE indicates vital information.

2.2 Safety Instructions

OWNER/OPERATOR'S RESPONSIBILITY

The procedures listed in this manual may not include all ANSI, OSHA, or locally required safety procedures. **It is the owner/operator's responsibility and not Wood-Mizer LLC to ensure all operators are properly trained and informed of all safety protocols.** Owner/Operators are responsible for following all safety procedures when operating and performing maintenance to the equipment.

OBSERVE ALL SAFETY INSTRUCTIONS

NOTICE Read the entire Operator's Manual before operating this equipment.

Note all safety warnings throughout this manual and those posted on the machine.

Be able to access this manual at all times while operating this equipment.

Read additional manufacturer's manuals and observe their applicable safety instructions.

Only persons who have read and understood the entire operator's manual should operate this equipment.

This equipment is not intended for use by or around children.

It is the owner/operator's responsibility to comply with all applicable federal, state, and local laws, rules, and regulations regarding the ownership, operation, and transporting your equipment.

Operators should become thoroughly familiar with and comply with these applicable laws for operating and transporting equipment.

 **WARNING!** Clean sawdust from all guards, vents, control boxes, or any area where sawdust may gather **after every shift**. Failure to

do so may result in fire, causing death or serious injury.

WEAR SAFETY CLOTHING

 **WARNING!** Secure all loose clothing and jewelry before operating the equipment.

Always wear eye, ear, and foot protection when operating or servicing the equipment.

Wear hand protection while servicing the equipment blades.

Wear respiratory protection when sawing woods that require it. (It is up to the sawyer to know which woods require respiratory protection.)

HANDLE FUEL/LUBRICANTS SAFELY

 **DANGER!** Due to the flammable nature of fuel and oil, never smoke, weld, grind or allow sparks near your engine or storage tanks, especially during times of fueling.

Do not allow fuel to spill on a hot engine during fueling operations or otherwise.

 **WARNING!** Store gasoline away from sawdust and other flammable materials.

Do not use flammable fuels or liquids such as diesel fuel. Use **ONLY** water and Wood-Mizer Lube Additive with the water lube accessory.

EQUIPMENT SETUP

 **DANGER!** Do not operate the equipment without **all** covers and guards in place.

 **WARNING!** Set up the equipment on solid, level ground.

Keep all persons out of the area between the frame rails while loading and unloading the equipment.

CHECK EQUIPMENT BEFORE OPERATION

 **DANGER!** Ensure all guards and covers are in place and secured before operating or towing the equipment.

Use the safety retainer pin and cable to fasten blade housing covers.

 **WARNING!** Do not operate the equipment without the bed end retaining brackets properly installed; the saw head may fall from the log bed.

KEEP PERSONS AWAY

 **DANGER!** Keep all persons out of the path of moving equipment and logs when operating equipment or loading and turning logs.

Ensure the blade is disengaged and all persons are out of the path of the blade before starting the engine or motor.

KEEP HANDS AWAY

 **DANGER!** Remove power before clearing debris or any other maintenance activity.

Disengage the blade and shut off the equipment engine before changing the blade.

 **WARNING!** Avoid contact with any hot parts (motors).

Allow the system to cool sufficiently before beginning any service function, including debris removal.

Avoid contact with sharp edges of the cutting blades.

Stay a safe distance from rotating members (shafts, pulleys, fans, etc.) and ensure loose clothing or long hair does not engage rotating members

Do not spin the blade wheels by hand. Spinning the blade wheels by hand may result in serious injury.

Disengage the clutch/brake mechanism whenever the equipment is not cutting.

Do not adjust the engine drive belt with the engine running.

Keep hands, feet, etc., clear of exiting sawdust chute when operating equipment.

UP/DOWN SYSTEM SAFETY

 **WARNING!** Secure the saw head with a chain with a minimum of 1900 lbs. working load capacity before adjusting the up/down chain.

Release pressure from the up/down assist prior to performing any service to the assembly. Parts are under tension and may fly apart.

Do not disassemble the pressurized cylinder. Parts are under pressure and may fly apart or damage the cylinder.

KEEP SAFETY LABELS IN GOOD CONDITION

NOTICE Ensure that all safety decals are clean and readable. Replace all damaged safety decals to prevent personal injury or damage to the equipment. Contact your local

distributor, or call your Customer Service Representative to order more decals.

NOTICE If replacing a component that has a safety decal affixed to it, ensure the new component also has the safety decal affixed in the same place.

KEEP MILL AND AREA AROUND MILL CLEAN

 **WARNING!** Maintain a clean and clear path for all necessary movement around the mill and material stacking areas.

Do not allow children in the area of the mill.

GAS OR DIESEL ENGINE OPERATION

 **DANGER!** Operate your engine/machine only in well ventilated areas.

Do not operate an engine with a fuel or oil leak.

 **WARNING!** Do not operate engine without proper and operational spark arrester/muffler.

DISPOSE OF WOOD BY-PRODUCTS PROPERLY

NOTICE Properly dispose of all wood by-products, including sawdust, chips, and other debris, including operation waste such as oil, filters, etc.

WORKING WITH BATTERIES

 **DANGER!** Batteries expel explosive gases; keep sparks, flames, burning cigarettes, or other ignition sources away at all times.

 **WARNING!** Always wear safety goggles and a face shield when working near batteries.

Wash hands after handling batteries to remove possible lead, acid, or other contaminants.

Charge the battery in a well ventilated area.

Do not attempt to charge a frozen battery.

 **CAUTION!** Do not overcharge the battery. Overcharging may reduce the overall service life of the battery.

Ensure the battery is fully charged before transporting the equipment. If the battery is not fully charged, excessive vibration could reduce the overall service life of the battery.

NOTICE When working with batteries, use extreme care to avoid spilling or splashing electrolyte (dilute sulfuric acid) as it can destroy clothing and burn the skin.

EMERGENCY TREATMENT FOR CONTACT WITH BATTERY COMPONENTS (LEAD/SULFURIC ACID) per SDS (Safety Data Sheet):

EYE CONTACT	Sulfuric Acid and Lead: Flush eyes immediately with large amounts of water for at least 15 minutes while lifting lids. Seek immediate medical attention.
SKIN CONTACT	Sulfuric Acid: Flush affected area(s) with large amounts of water using deluge emergency shower, if available, shower for at least 15 minutes. Remove contaminated clothing, including shoes. If symptoms persist, seek medical attention. Wash contaminated clothing before reuse. Discard contaminated shoes. Lead: Wash immediately with soap and water.
INGESTION	Sulfuric Acid: Administer large amounts of water. Do NOT induce vomiting or aspiration into the lungs may occur and can cause permanent injury or death; consult physician.
INHALATION	Sulfuric Acid: Remove to fresh air immediately. If not breathing, give artificial respiration. If breathing is difficult, give oxygen. Consult a physician. Lead: Remove from exposure, gargle, wash nose and lips; consult physician.

2.3 Electrical Lockout Procedures

RULES FOR USING LOCKOUT PROCEDURE

The equipment shall be locked out to protect against accidental or inadvertent operation when such operation could cause injury to personnel. Do not attempt to operate any switch or valve bearing a lock.

LOCKOUT PROCEDURES MUST BE USED DURING, BUT NOT LIMITED TO:

- Changing or adjusting blades
- Unjamming operations
- Cleaning
- Mechanical repair
- Electrical maintenance
- Retrieval of tools/parts from work area
- Activities where guards or electrical panel guard is open or removed

MAINTENANCE HAZARDS INCLUDE, BUT NOT LIMITED TO:

- Blade contact
- Pinch points
- Kickbacks
- Missiles (thrown blades/wood chips)
- Electrical

FAILURE TO LOCKOUT MAY RESULT IN, BUT NOT LIMITED TO:

- Cut
- Crush

- Blindness
- Puncture
- Electrocutation
- Serious injury and death
- Amputation
- Burn
- Shock

TO CONTROL MAINTENANCE DANGERS:

- Lockout procedures must be followed (see **OSHA regulation 1910.147**).
- Never rely on machine stop control for maintenance safety (emergency stops, on/off buttons, interlocks).
- Do not reach into moving blades or feed systems. Allow all coasting parts to come to a complete stop.
- Electrical power supply and air supply must both be locked out.
- Where established lockout procedures cannot be used (electrical troubleshooting or mechanical dynamic troubleshooting), alternative effective protective techniques shall be employed which may require special skills and planning.
- Always follow safe operations practices in the workplace.

EQUIPMENT LOCKOUT PROCEDURE

Lockout procedures per OSHA regulation 1910.147, appendix A:

GENERAL

The following simple lockout procedure is provided to assist owner/operators in developing their procedures so they meet the requirements of **OSHA regulation 1910.147**. When the energy isolating devices are not lockable, tagout may be used, provided the owner/operator complies with the provisions of the standard which require additional training and more rigorous periodic inspections. When tagout is used and the energy isolating devices are lockable, the owner/operator must provide full operator protection (see OSHA regulation 1910.147, paragraph (c)(3)) and additional training and more rigorous periodic inspections are required. For more complex systems, more comprehensive procedures may need to be developed, documented, and utilized.

PURPOSE

This procedure establishes the minimum requirements for the lockout of energy isolating devices whenever maintenance or servicing is done on machines or equipment. It shall be used to ensure that the machine or equipment is stopped, isolated from all potentially hazardous energy sources and locked out before personnel perform any servicing or maintenance where the unexpected energization or start-up of the machine or equipment or release of stored energy could cause injury.

COMPLIANCE WITH THIS PROGRAM

All personnel are required to comply with the restrictions and limitations imposed upon them during the use of lockout. The authorized personnel are required to perform the lockout in accordance with this procedure. All operators,

upon observing a machine or piece of equipment which is locked out to perform servicing or maintenance shall not attempt to start, energize, or use that machine or equipment.

SEQUENCE OF LOCKOUT

1. Notify all affected personnel that servicing or maintenance is required on a machine or equipment and that the machine or equipment must be shut down and locked out to perform the servicing or maintenance.
2. The authorized employee shall refer to the company procedure to identify the type and magnitude of the energy that the machine or equipment utilizes, shall understand the hazards of the energy, and shall know the methods to control the energy.
3. If the machine or equipment is operating, shut it down by the normal stopping procedure (depress the stop button, open switch, close valve, etc.).
4. De-activate the energy isolating device(s) so that the machine or equipment is isolated from the energy source(s).
5. Lock out the energy isolating device(s) with assigned individual lock(s).
6. Stored or residual energy (such as that in capacitors, springs, elevated machine members, rotating flywheels, hydraulic systems, and air, gas, steam, or water pressure, etc.) must be dissipated or restrained by methods such as grounding, repositioning, blocking, bleeding down, etc.
7. Ensure that the equipment is disconnected from the energy source(s) by first checking that no personnel are exposed, then verify the isolation of the equipment by operating the push button or other normal operating control(s) or by testing to make certain the equipment will not operate.

 **CAUTION!** Return operating control(s) to neutral or "off" position after verifying the isolation of the equipment.

8. The machine or equipment is now locked out.

RESTORING EQUIPMENT TO SERVICE

When the servicing or maintenance is completed and the machine or equipment is ready to return to normal operating condition, the following steps shall be taken.

1. Check the machine or equipment and the immediate area around the machine to ensure that nonessential items have been removed and that the machine or equipment components are operationally intact.
2. Check the work area to ensure that all personnel have been safely positioned or removed from the area.
3. Verify that the controls are in neutral.
4. Remove the lockout devices and re-energize the machine or equipment.

NOTE: The removal of some forms of blocking may require re-energization of the machine before safe removal.

5. Notify affected personnel that the servicing or maintenance is completed and the machine or equipment is ready for use.

PROCEDURE INVOLVING MORE THAN ONE PERSON

In the preceding steps, if more than one individual is required to lock out the equipment, **each shall place his own personal lock on the energy isolating devices.**

SECTION 3 SAWMILL SETUP

3.1 Sawmill Setup



WARNING! Set up the mill on the flat ground.

If setup on an incline is necessary, put blocks under one side of the mill or dig out areas for outrigger legs to keep mill level. Setting up the mill on an incline could cause it to tip over, resulting in serious personal injury.

WARNING! Chock the trailer wheels to prevent movement before unhitching it from the towing vehicle.

WARNING! Always make sure the trailer is supporting the sawmill frame when operating a sawmill with adjustable outriggers.

WARNING! The adjustable outriggers supplied with portable sawmills are not intended for setup on concrete or other hard surfaces. Long-term use of the adjustable outriggers on hard surfaces may cause the outriggers to fail, causing the sawmill to drop.

If setting the sawmill up on concrete or other hard surface, replace the adjustable outrigger legs with stationary legs.



WARNING! Before moving the saw carriage, remove the operator control box and stand from the travel locations at the front of the sawmill frame.

REMOVE THE OPERATOR CONTROL BOX AND STAND

6. Remove the retaining pin securing the control stand to the travel bracket. See FIG. 3-1.
7. Lift the stand from the bracket turn so the legs are at the bottom and set on the ground.
8. Remove the retaining pin securing the control box to the travel bracket. See FIG. 3-1.

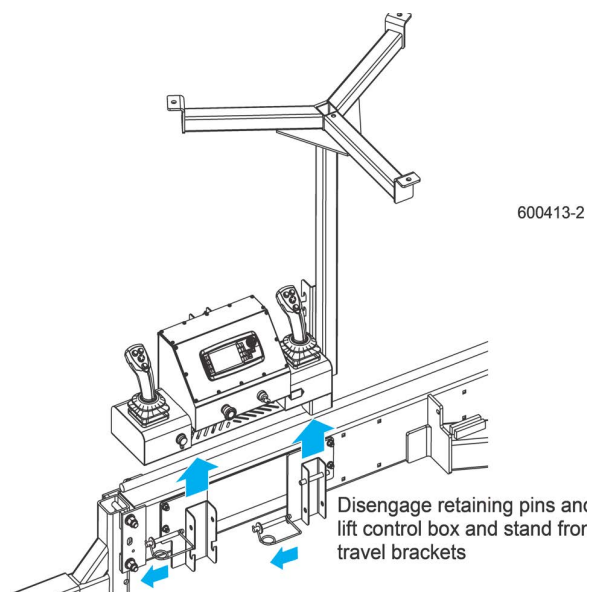

FIG. 3-1

9. Lift the control box from the bracket and set on the stand at the desired height. .
10. Secure the control box to the stand with the retaining pin in the uppermost bracket hole. See FIG. 3-2.
11. Place the control/stand assembly in the desired location.
12. Connect the cable from the hydraulic pump control to the port on the back of the operator control.

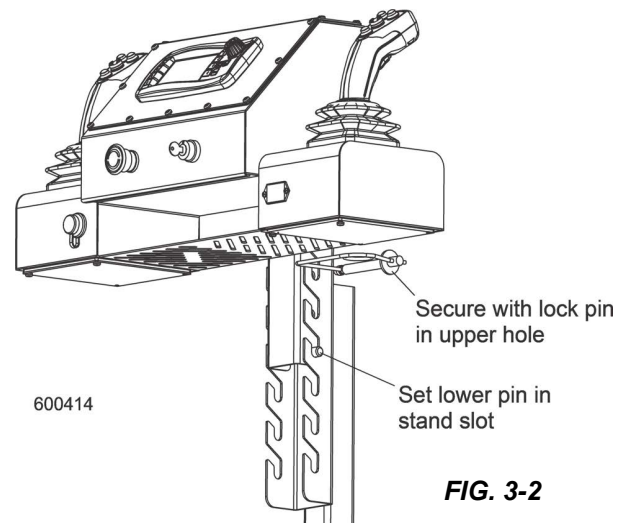



FIG. 3-2

LOWER THE OUTRIGGERS

1. Unlatch the mill from the vehicle.
2. Lower and set the front three outriggers

 **WARNING!** Put front outrigger down before moving cutting head from the rest position. Failure to do so may result in serious injury.

- 1). Remove the locking pin and adjust the leg down. See FIG.3-3
 - 2). Replace the locking pin and use the crank to adjust the outrigger as desired.
3. Unhook the carriage safety chain, located at the bottom of the vertical mast
 4. Start the engine to enable the battery-operated accessories ([See Section 3.6](#)).
 5. Pull the left joystick back to raise the cutting head from the carriage rest pin.
 6. Remove the locking pin and swing the rest pin down below bed level.
 7. Remove the fenders by lifting them out of the slots.

 **CAUTION!** To prevent fender damage, remove fenders before operating sawmill or loading logs.

8. Pull the right joystick back to move the cutting head toward the front end of the mill.
9. Lower and set the remaining rear outriggers.
10. Level the sawmill by adjusting the outriggers to raise or lower each end of the sawmill.
11. Adjust all outriggers evenly to avoid twisting the mill frame by jacking one outrigger higher than the others.

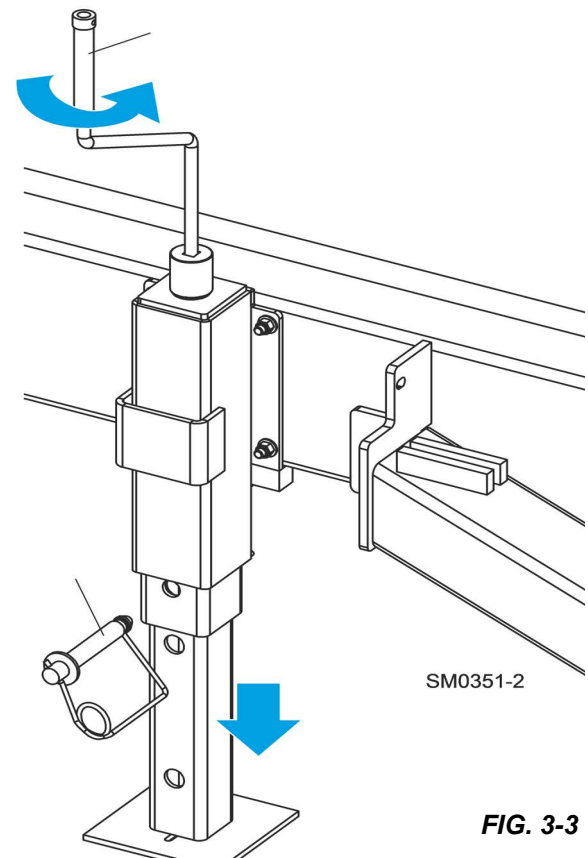

FIG. 3-3

SETUP THE BOARD RETURN TABLE FOR OPERATION.

1. First, remove three retaining pins to detach the long table assembly from the sawmill.

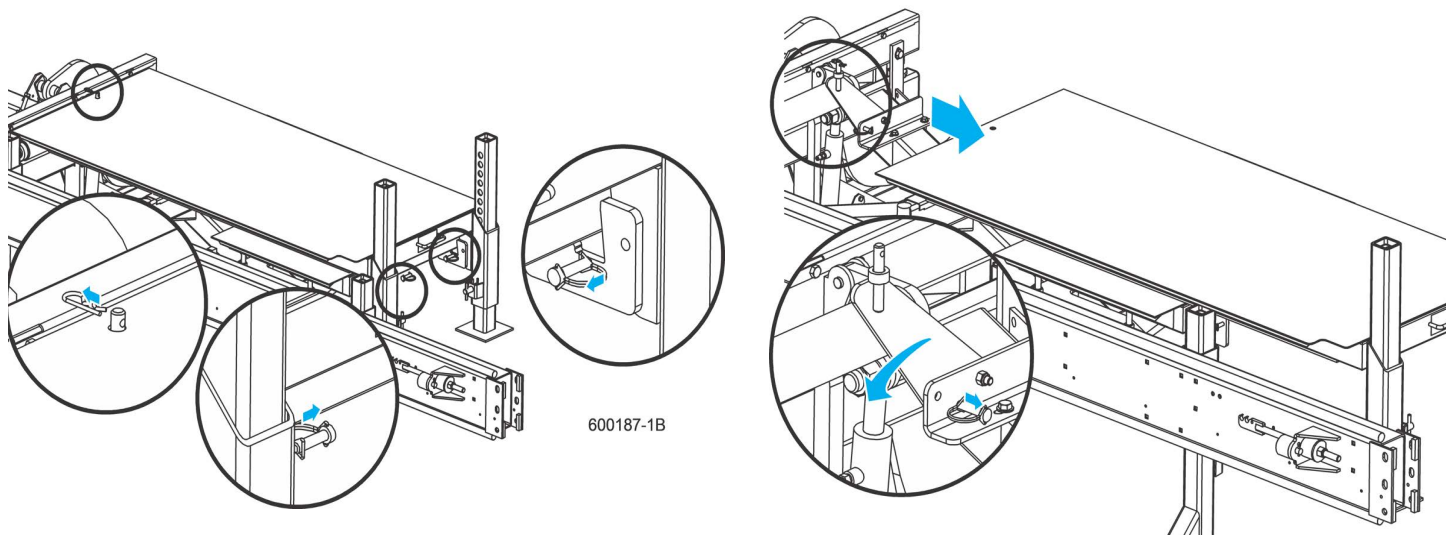
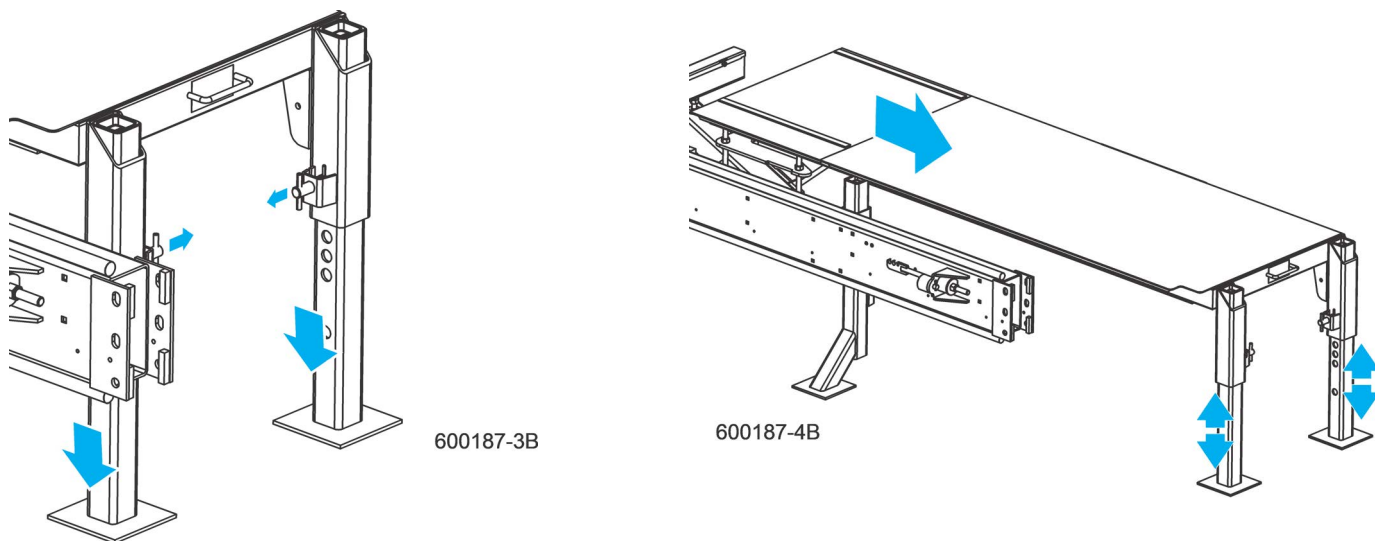

FIG. 3-4

2. Lift the long table assembly off the rest pin and slide toward the front of the mill.
3. Rest the long table on the short bottom table so it is balanced.
4. Replace the three retaining pins.
5. Remove the rest pin retaining pin and pivot the rest pin down below bed level.
6. Replace the retaining pin.
7. Pull the outrigger pins and lower the legs.



8. Slide the long table until it rests in position, level with the short table assembly.
9. If necessary, adjust the outrigger legs up or down so the table is level.

3.2 Installing The Blade



DANGER! Always disengage the blade and shut off the sawmill engine before changing the blade.



WARNING! Always wear gloves and eye protection when handling bandsaw blades. Changing blades is safest when done by one person! Keep all other persons away from area when coiling, carrying or changing a blade.

1. Open the two blade housing covers that cover the blade wheels.
2. Release the blade tension handle to release the hydraulic pressure until the wheel is pulled in and the blade is lying loose in the blade housing.
3. Lift the blade out of the blade housing.

When installing a blade, make sure the teeth are pointing the correct direction. The teeth should be pointing toward the operator side (dust chute side) of the mill.

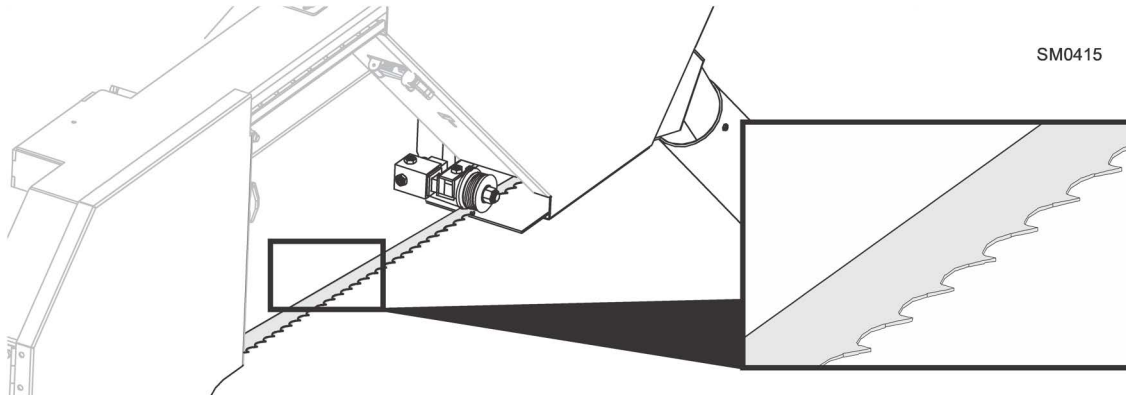

FIG. 3-6

4. Install the blade so it is lying around the wheels.



CAUTION! Be careful when placing the blade between the blade guide inserts. If the blade hits one of the inserts hard enough, it could damage the insert.

5. Position 1 1/4" wide blades on the wheels so the gullet is 1/8" (3.0 mm) out from the edge of the wheel.
6. Position 1 1/2" wide blades on the wheels so the gullet is 3/16" (4.5 mm) out from the edge of the wheel.
7. Close the blade housing covers.
8. Use the tension handle to tension the blade correctly.

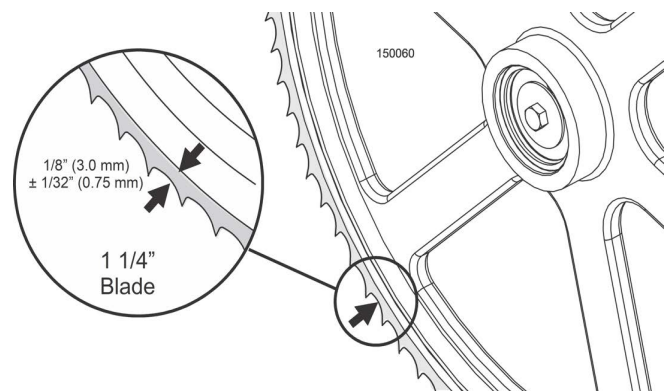

FIG. 3-7

3.3 Tensioning The Blade

1. Check the air pressure gauge to see that the air tension system is properly charged before tensioning the blade.

With the blade tension completely released and the air bag plate against the stop bolt, the gauge should read 85 psi for all blade types.

2. Add air pressure by removing the air valve stem cover and attach an air pump to the air valve.
3. Add air until the gauge indicates the proper air pressure.
4. Release air by pushing in the valve stem core.
5. Replace the air valve stem cover when finished adjusting the air pressure.
6. Pump the lever until the air bag plate is approximately 1/8" (3.0mm) from the stop plate.
7. Release blade tension by turning the release valve counterclockwise to open.
8. Pry the assembly forward until the blade can be removed.

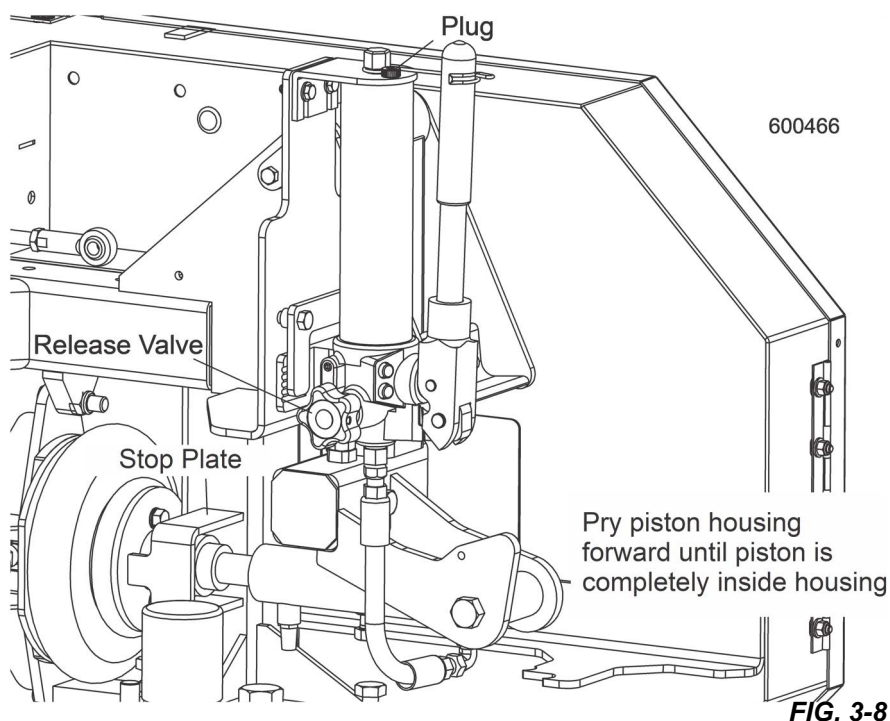

The tension gauge should be checked occasionally when adjusting the cant control or while cutting. Ambient temperature changes will cause tension to change. Adjust the tension handle as necessary to maintain the recommended tension level.

3.4 Tracking The Blade

1. Make sure the blade housing covers are closed and all persons are clear of the open side of the saw head.
2. Start the engine (or motor).
3. Engage the blade, rotating the blade until the blade positions itself on the wheels.

WARNING! Do not spin the blade wheels by hand. Spinning the blade wheels by hand may result in serious injury.

4. Disengage the blade.
5. Turn off the engine, remove the key, and check the position of the blade on the blade wheels.
6. Position **1 1/4" wide blades** so the gullet is 1/8" (3.0 mm) out from the edge of the blade wheel ($\pm 1/16$ [1.5 mm]).
7. Position **1 1/2" blades** so the gullet is 3/16" (4.5 mm) out from the edge of the blade wheel ($\pm 1/16$ [1.5 mm]).

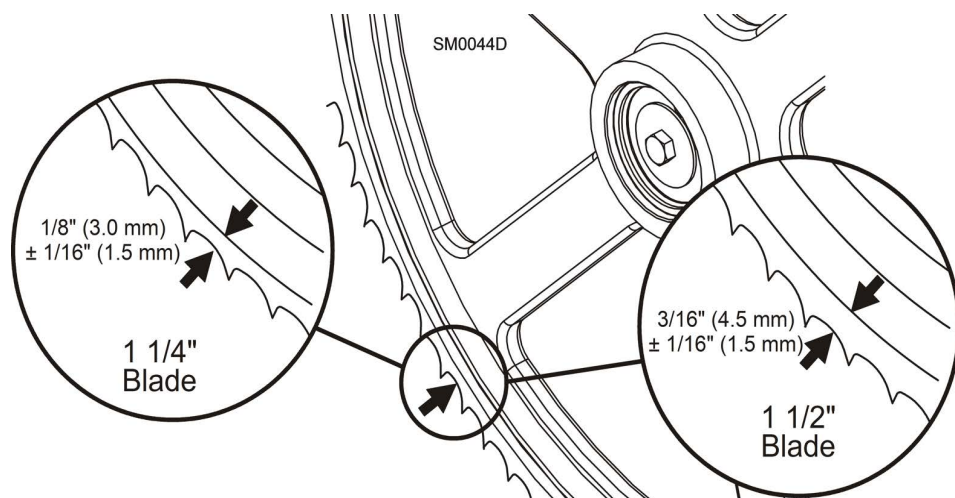

FIG. 3-9

8. Use the cant adjustment bolt to adjust where the blade travels on the blade wheels.
9. Turn the cant adjustment bolt clockwise to move the blade out on the blade wheel, or counterclockwise to move the blade in.

NOTE: Slight adjustments of the side bolts on the outer blade wheel are usually all that is necessary to track the blade properly. [See Section 7.2](#) for complete blade wheel alignment instructions.

10. Close the blade housing covers, tension the blade, and spin the blade again.
11. Repeat this procedure until the blade tracks on the blade wheels properly.
12. Adjust the blade tension if necessary to compensate for any changes that may have occurred while adjusting the cant control.

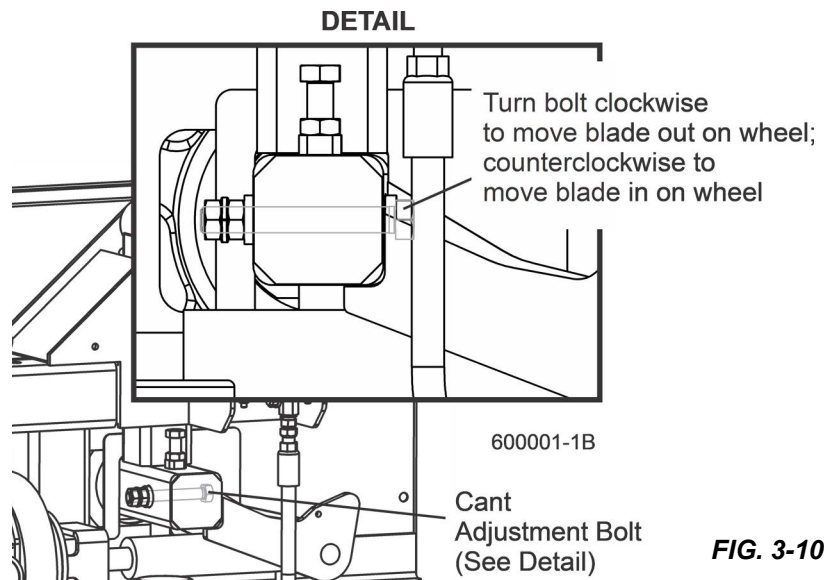

FIG. 3-10

DANGER! Make sure all guards and covers (including the blade housing and pulley covers) are in place and secured before operating or towing the sawmill.

NOTICE After aligning the blade on the wheels, always double-check the blade guide spacing and location. ([See Section SECTION 7](#) for more information.)

3.5 Starting The Engine or Motor

See the appropriate manual supplied with your specific engine/motor configuration for starting and operating instructions.

DANGER! Make sure all guards and covers (including the blade housing and pulley covers) are in place and secured before operating or towing the sawmill.

Always be sure the blade is disengaged and all persons are out of the path of the blade before starting the engine or motor.

WARNING! Always wear eye, ear, respiration, and foot protection when operating the sawmill.

Be sure the power feed switch (if equipped) is in the neutral position before turning the key switch to the on (#1) or accessory(#3) position to prevent accidental carriage movement .

3.6

3.7 Board Return

WARNING! The automatic board return is intended to assist a second operator in removing boards quickly. Do not use the board return when operating the sawmill alone.

WARNING! Do not stand on the board return table.

The sawmill is equipped with a board return system. This system consists of arms on the saw head and a board return table to catch the board as it is removed from the log.

NOTE: Use of the board return not recommended with material shorter than 8 foot.

When the blade reaches the end of the log, the arms will drop down to catch the board and drag it back toward the operator as the saw head is returned.



WARNING! Keep all persons out of the path of returning boards.

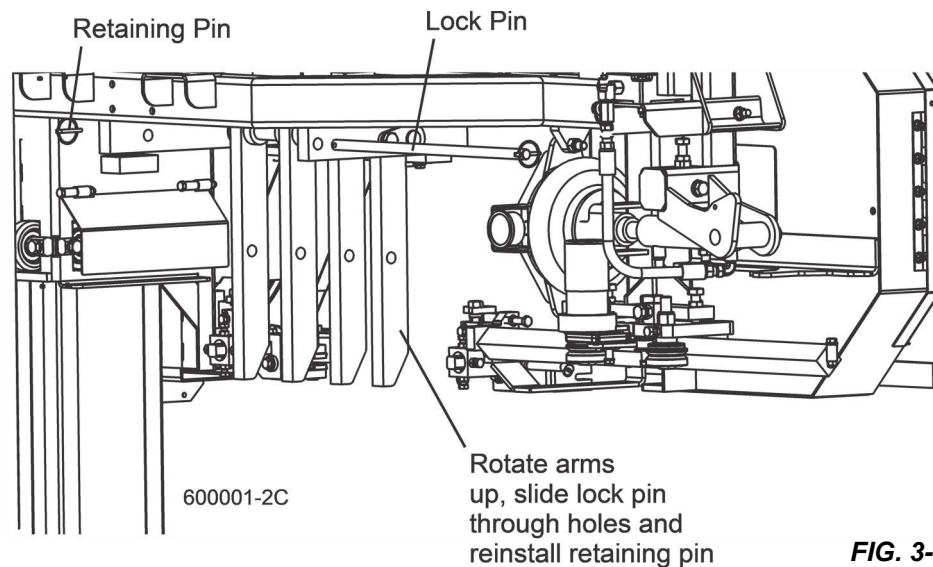

FIG. 3-11

Boards may not always return in the same path or location. If a board returns in a manner that does not allow the off-bearer to maintain control, it may be necessary to stop the reverse motion of the saw head.

When the board return is to be used, a second person is required to remove the board as it is returned.



CAUTION: DO NOT attempt to use the board return feature when sawing alone.

To bypass the board return feature, pin the board return arms in the storage position.

3.8 Debarker Setup

Check and adjust debarker alignment as required.



DANGER! Before performing any service to this equipment, turn the key to the OFF (0) position and remove the key. Failure to do so will result in serious injury or death.

The debarker blade should be aligned to the sawmill blade to insure proper operation. The debarker blade should be parallel with and aligned vertically with the sawmill blade.

1. Turn the key to ON (2) and move the debarker all the way in.
2. Turn the key to OFF (0) and remove the key to prevent the debarker from being turned on while performing alignment procedures.
3. Check the squareness of the debarker with the sawmill blade.
4. Adjust the debarker mounts if necessary until the debarker is square with the sawmill blade.
 - a. Loosen the bottom debarker mounting bolt and loosen the jam nuts on the adjustment bolts.
 - b. Turn the adjustment bolts as necessary until the debarker is square with the sawmill blade.
 - c. Retighten the jam nuts and bottom debarker mounting bolt.
5. Clip the blade guide alignment tool to the sawmill blade.

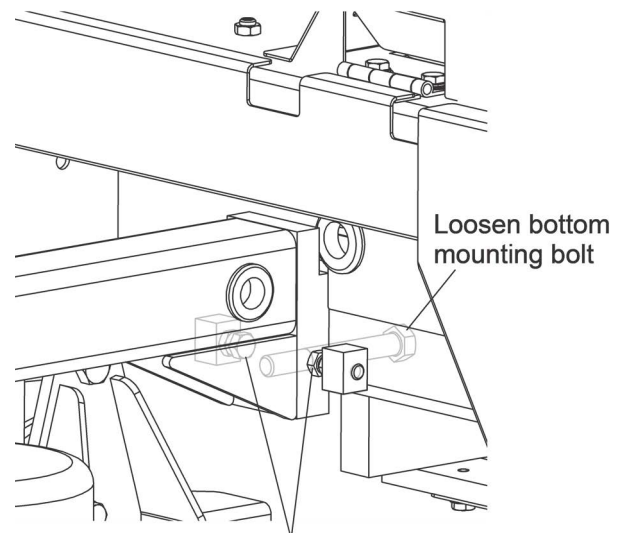

Loosen jam nuts and adjust bolts to square debarker with sawmill blade

FIG. 3-12

6. Ensure the tool lies flat on the blade and does not contact a tooth that could cause it to angle.
7. Check the height of the debarker blade against the alignment tool.

The bottom edge of the tool should align with the center of the debarker blade.

- a. Adjust the blade up or down by loosening the four blade motor mount bolts.
- b. Loosen the jam nut on the adjustment bolt.
- c. Turn the adjustment bolt clockwise to push the motor and blade down.
- d. Turn the adjustment bolt counterclockwise and slide the motor up to raise the motor and blade.
- e. Retighten the adjustment bolt jam nut and four motor mount bolts.

8. Insert the key and use the debarker in/out switch to move the debarker all the way out.
9. Turn the key to OFF (0) and remove the key.
10. Move the blade guide alignment tool on the sawmill blade and check the position of the debarker blade against the tool.
11. Readjust the debarker mounting bolts to adjust the debarker assembly parallel to the blade.

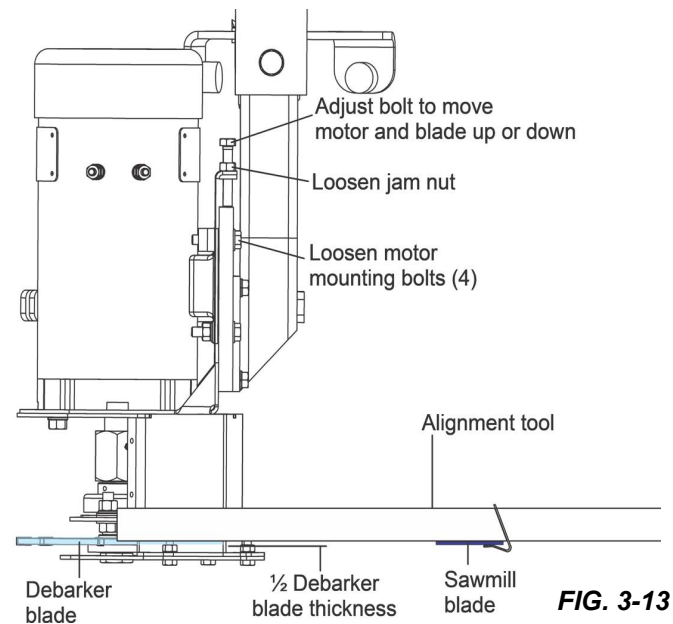

FIG. 3-13

SECTION 4 SAWMILL OPERATION

4.1 Hydraulic Control Operation

The hydraulic controls become operational when the engine is running.

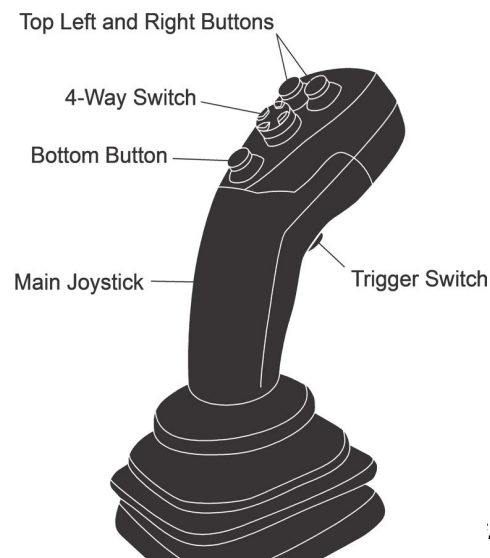
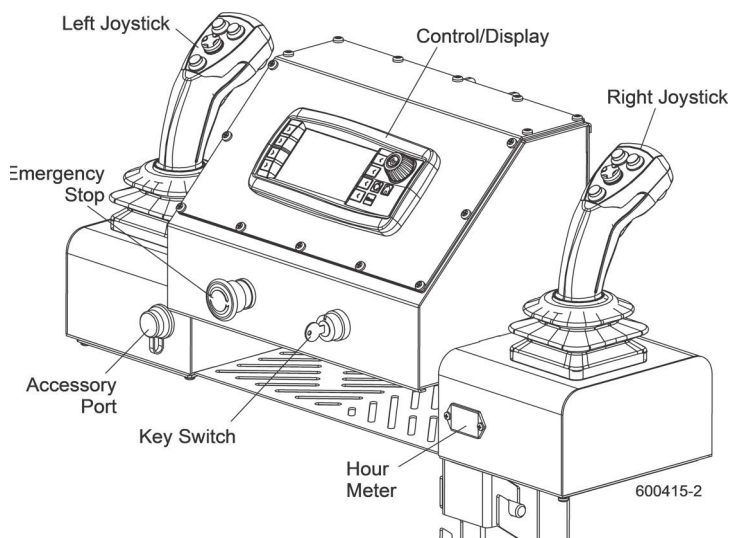

FIG. 4-1

The joysticks located at the operator box control all of the sawmill functions. Each joystick can be moved forward, backward, left and right to perform various functions. Each joystick also has a 4-way switch, three front buttons and a trigger switch to perform additional functions.

The sawmill comes with four configurations of the joystick controls: 1 (Front Right Hand - Default), 2 (Front Left Hand), 3 (Back Right Hand) and 4 (Back Left Hand). All of the reference in this section will be related to the default layout (1 - Front Right Hand).



To toggle between head and bed functions, press the trigger switch of the left joystick. The Bed/Head Mode icon on the Main Screen will indicate if the controls are in Bed Mode or Head Mode.

Use the joystick controls to get the mill ready to load a log.



DANGER! Keep all persons out of the path of moving equipment and logs when operating sawmill or loading and turning logs. Failure to do so will result in serious injury.

1. Turn the key switch to start the engine.
2. Press the left joystick trigger switch to place the control in Bed Mode.
3. Move the clamp out and down so it will not get in the way of logs being loaded onto the bed:
4. Move the right joystick to the right to move the clamp out toward the loading side of the sawmill.
5. Push the right joystick forward to lower the clamp below bed level.
6. Move the left joystick to the left to extend the legs of the log loader out as far as they will go.
7. **Wide Head Models Only:** Remove the loading arm lock pin securing the log loading arms in the travel position.

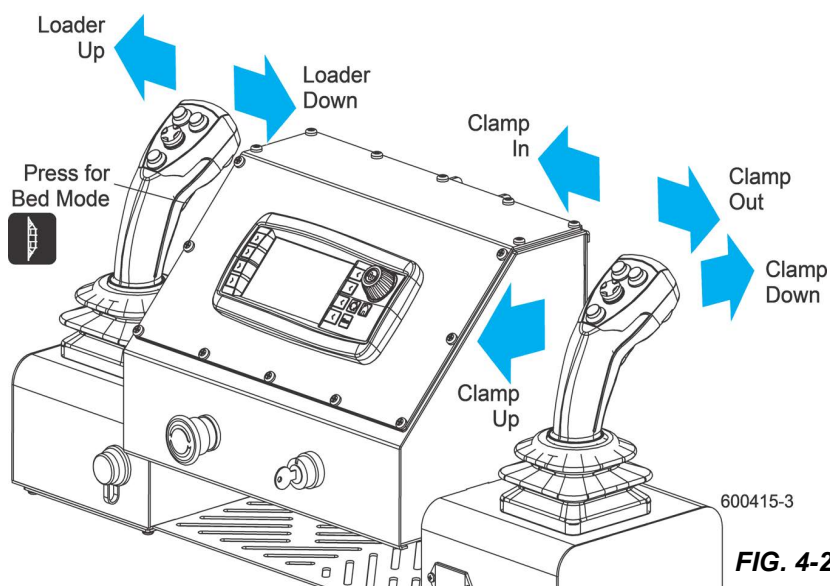

FIG. 4-2

The chain securing the log loading arm to the log turner arm will be tight.

8. Raise the log turner lever to raise the turner arm until there is slack in the chain.
9. Unchain the loading arm from the turner arm.
10. Move the left joystick forward to completely lower the turner arm.

After the turner arm is all the way down, the side support braces will begin to lower.

11. Release the joystick after the turner arm is lowered, but before the side supports begin to lower.

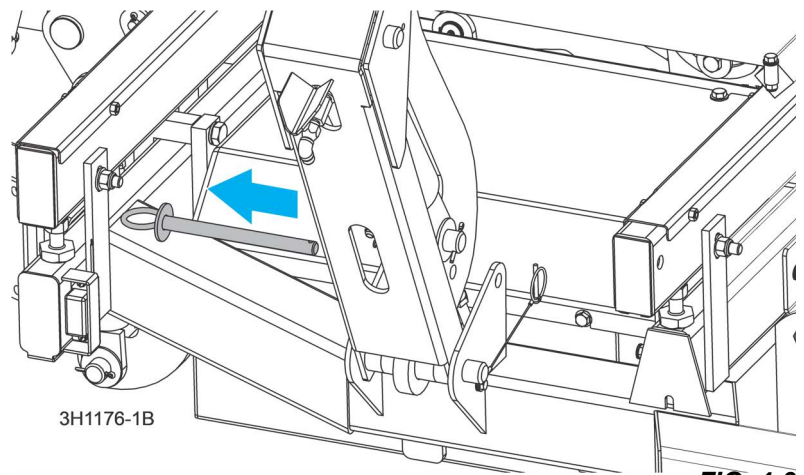

FIG. 4-3

This stops the log being loaded from damaging the turner and/or falling off the side of the sawmill.

When raising the turner, the side supports rise first. After reaching a fully vertical position, the turner arm will engage and start to rise.

12. Manually lower the log loader so it rests on the ground.



CAUTION! Be careful when manually lowering the log loader. Do not drop the loader onto the ground or perform any action which might break the velocity fuse valves on the loader cylinders. These valves control hydraulic flow and are necessary to prevent the loading arm from collapsing during use.

13. Load logs onto the sawmill bed:

If using the optional log deck, push the 4-way switch on the right joystick to move logs onto the sawmill bed.

If using the standard log loading arm, move the left joystick to the right to lower the loading arm as far as it will go. Logs must be rolled onto the loading arm one at a time for loading onto the bed of the mill.

The front and rear toe boards should be below bed level. Once a tapered log has been loaded, the front or rear end of the log may be lifted to parallel the heart of the log to the path of the blade.

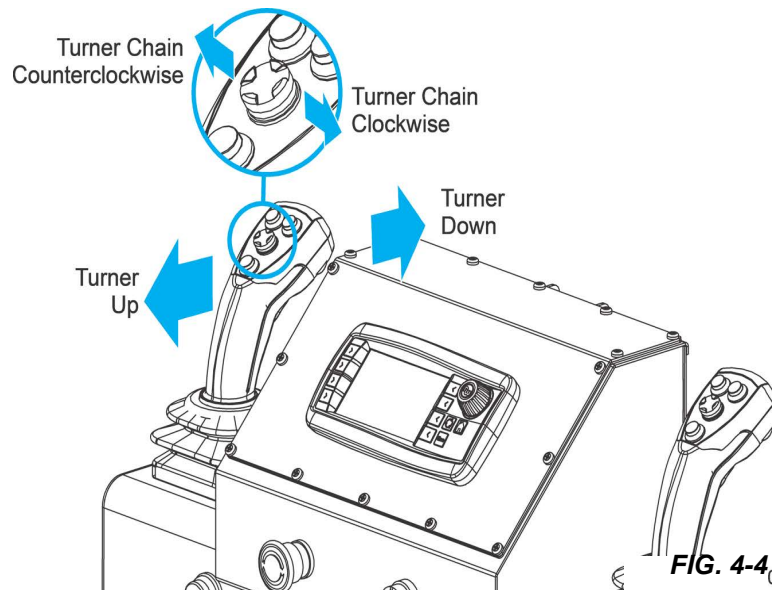

FIG. 4-4

14. Raise the front toe board by pressing and holding the bottom button and moving the left joystick to the left.
15. Raise the rear toe board by pressing and holding the bottom button and moving the left joystick to the right.
16. Cut a flat side to the log.
17. Turn the log by pressing one of the top buttons to lower either toe board until it falls below the level of the bed. (Pushing the 4-way switch down lowers both toe boards).

4.2 Loading, Turning And Clamping Logs

TO LOAD LOGS

1. Start the engine and move the saw carriage to the front end of the frame.



CAUTION! Before loading a log, be sure the cutting head is moved far enough forward so the log does not hit it. Failure to do so may result in machine damage.



CAUTION! Be sure the log clamp, pivot rails, turning arm and toe boards are adjusted out of the path of the log before loading a log onto the bed.

2. Raise the side supports on the sawmill bed to prevent the log from falling off the side of the bed.
3. Use cant hooks or loading equipment to move the log to the foot of the loading arms.
4. Roll the log onto the loader so that it is approximately centered with the sawmill bed. The log turner will operate much easier if the log is centered on the sawmill bed.



DANGER! Keep all persons out of the path of moving equipment and logs when operating sawmill or loading and turning logs. Failure to do so will result in serious injury.

5. Raise the loader to lift the log onto the sawmill bed. Simply let the loader rise until the log rolls onto the mill bed.
6. Raise the clamp up to prevent the log from rolling off the bed.
7. Clamp the log and lower the loading arm. Leave the loading arm about halfway up while squaring the log. This will stop the log from rolling off the side of the mill.



WARNING! Always leave loading arm halfway up while log is on sawmill bed.

NOTE: Logs also may be loaded onto the mill with a tractor or other equipment specifically designed for that purpose.

TO TURN LOGS

1. Engage the log turner arm. Let the arm rise until it touches the log.
2. Spin the log against the side supports until it is turned the way you want it for the first cut.

TO TURN LOGS (OPTIONAL PROCEDURE)

If you are turning a small cant on a mill with two-plane clamp, you may opt to use the clamp to turn the cant.

1. Lower the clamp below bed level.
2. Move the clamp in, beneath the edge of the cant.
3. Raise the clamp and flip the cant.

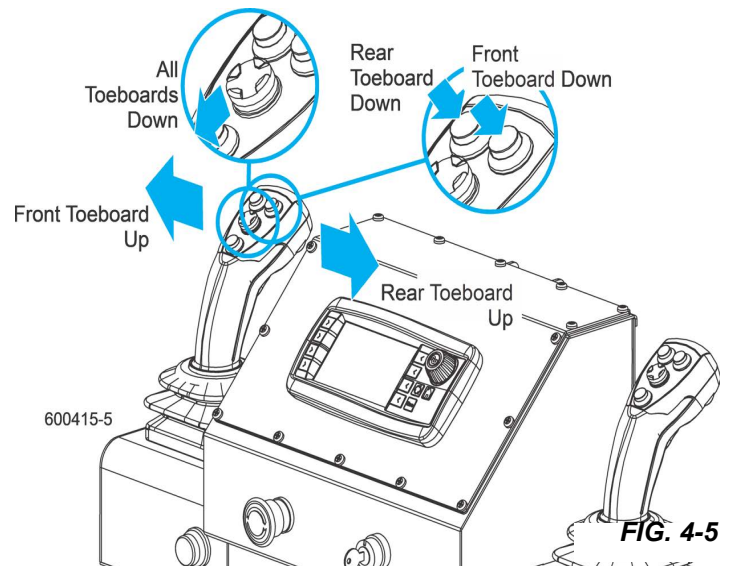

FIG. 4-5

TO CLAMP LOGS

1. Clamp the log against the side supports.
2. Lower the turner until the arm falls below the bed.
3. When the turner arm is lowered all the way, the side supports will begin to lower. Back the clamp off slightly, and let the side supports come down until they are positioned below the level of your first few cuts.

TO LEVEL A TAPERED LOG

Raise the front or rear toe board until the heart of the log measures the same distance from the bed rails at each end of the log.

4.3 Up/Down Operation

This section describes operation of the up/down system with the control in manual mode. [See Section 4.9](#) for alternate instructions for operating the up/down system in Auto or Pattern modes.

1. Install a blade, if needed, and check for correct blade tension ([See Section 3.4](#)).
2. Set the cutting head to the desired height (The control display shows the height of the blade above the bed rails).
3. Press the left joystick trigger switch to place the control in Head Mode.
4. Pull the left joystick back to raise the cutting head; push the joystick forward to lower the cutting head.

The further the joystick is pushed or pulled, the faster the cutting head will move up or down. Release the joystick when the cutting head reaches the desired height.

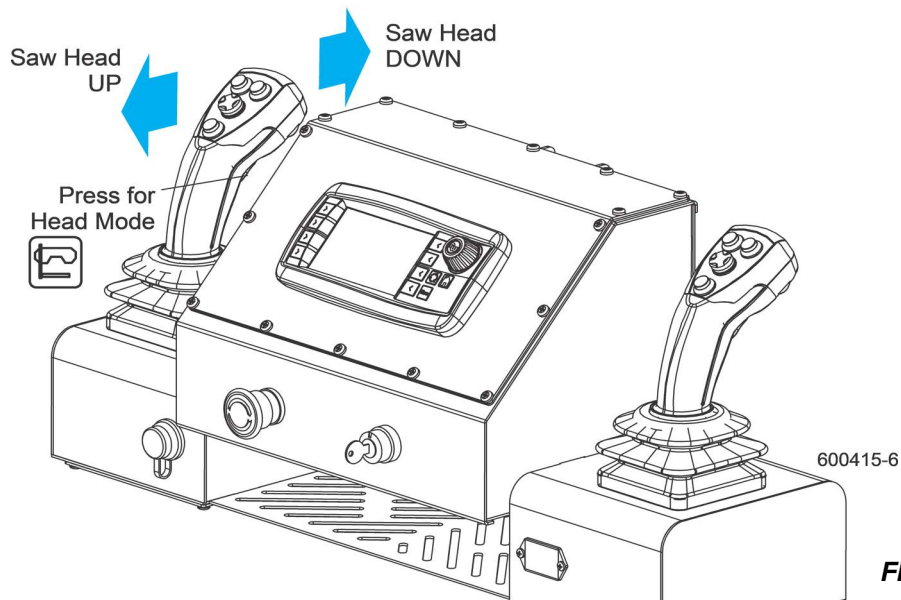

FIG. 4-6



CAUTION! DO NOT try to force the carriage above the 35" (88 cm) mark or below the 1" (2.54 cm) mark. Damage to the up/down system may result.

4.4 Blade Guide Arm Operation

1. Look down the length of the log to see its maximum width. The outer blade guide should be adjusted to clear the widest section of the log by less than 1" (25.4 mm).
2. Use the 4-way switch on the right hand joystick to adjust the outer blade guide as necessary.
3. Push the 4-way switch to the left to move the arm in.

4. Push the 4-way switch to the right to move the arm out.
5. Use the 4-way switch to re-adjust the outer blade guide as you are cutting in order to keep the guide within 1" (2.5 cm) of the log.
6. Be sure to adjust the arm back out before returning the carriage.

4.5 Autoclutch Operation

The sawmill is equipped with an automatic clutch mechanism that remotely engages/disengages the blade using a button on the control box (or the bottom button on the left joystick).

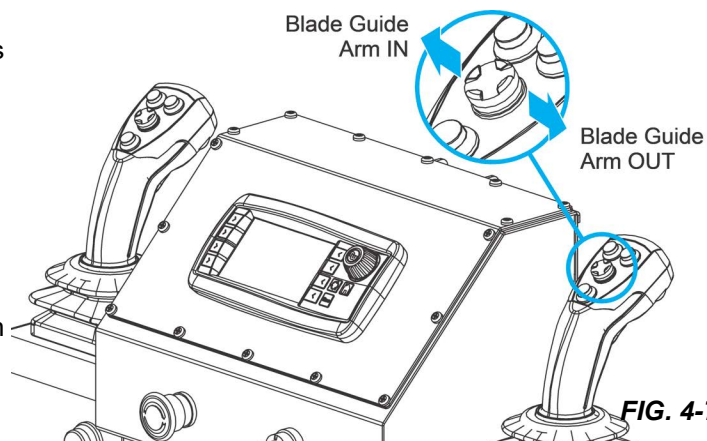

FIG. 4-7



To engage the blade, push the blade on/off button on the control panel (or press the bottom button on the left joystick). The autoclutch mechanism will disengage the brake, rev the motor to full throttle, and start the blade spinning.



DANGER! Keep all persons out of the path of moving equipment and logs when operating sawmill or loading and turning logs. Failure to do so will result in serious injury.

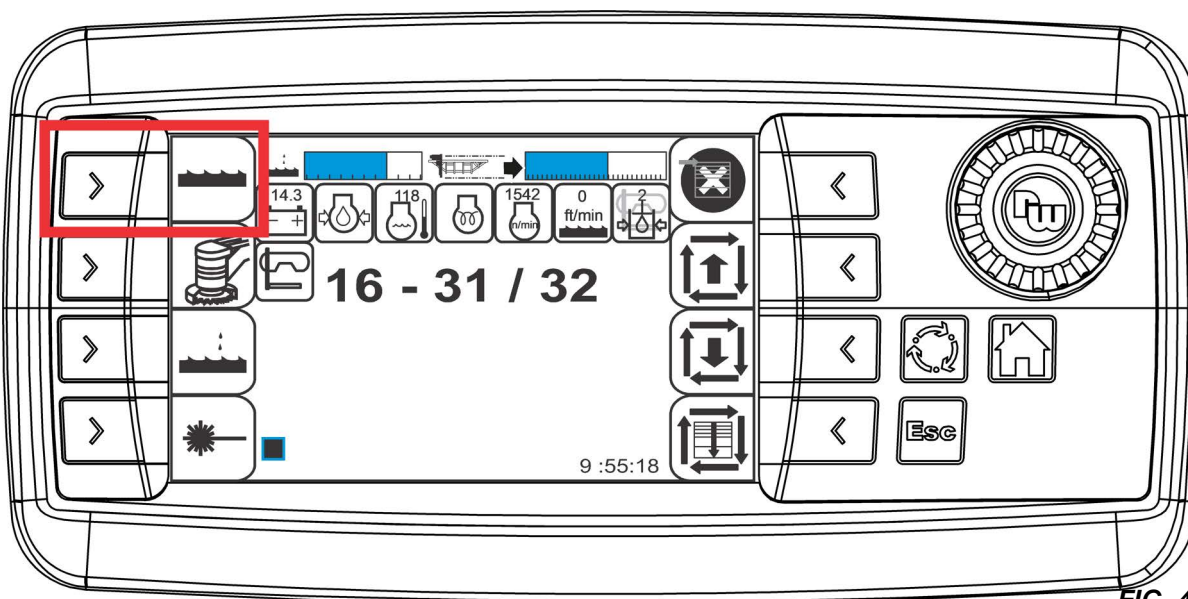

FIG. 4-8
600416-1B

To stop the blade and engage the blade brake, push the blade on/off button. This will also return the engine to idle.

4.6 Debarker Operation

The sawmill is equipped with a debarker that can be used when cutting the logs.



To turn the debarker on, push the debarker on/off button to highlight the debarker icon on the control panel. The debarker will engage when cutting the log and disengage when moving the saw head back to make another cut.

DANGER! Keep all persons out of the path of moving equipment and logs when operating sawmill or loading and turning logs.

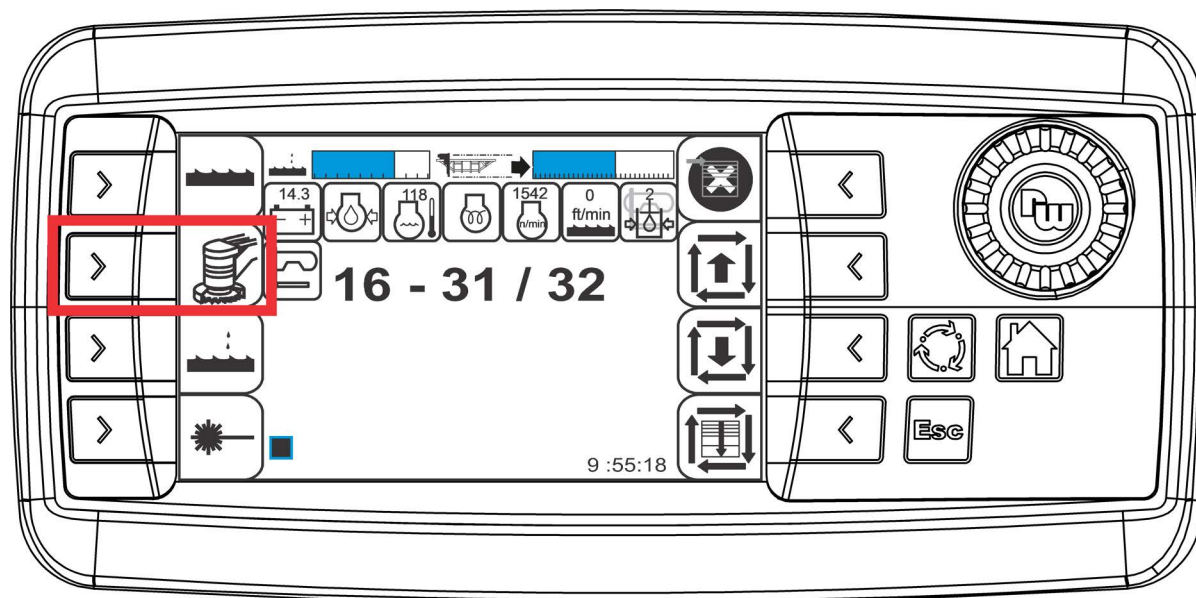
600416-2
FIG. 4-9

Push the debarker on/off button on the control panel again to turn the debarker off.

4.7 Power Feed Operation

The power feed system moves the carriage forward and backward by using the right joystick and the adjustment knob on the control panel.

CARRIAGE FEED RATE

The maximum speed at which the carriage travels forward is set by using the adjustment knob. The yellow box around the icon indicates the currently selected item. Turn the knob to highlight the speed rate icon on the main screen. Press the knob to select (the frame around the speed rate icon turns green to show it is ready for adjustment) and turn clockwise to increase the speed rate. Turn it counterclockwise to reduce speed. Press the knob when done adjusting the speed rate (the frame around the speed rate icon turns yellow).

CARRIAGE FORWARD AND REVERSE

The right joystick controls the direction in which the carriage travels. Push the joystick forward to move the carriage forward. Pull the joystick back to move the carriage backward. As you push the joystick further, the feed forward travel rate will increase (up to the speed set by the adjustment knob). The reverse travel rate is always at full speed.

Release the joystick to return to the neutral position.

Cruise Control: Push the right joystick forward and press the top right button on the left joystick to use the cruise control function. Release the right joystick. Press the cruise control button again or move the right joystick to turn the cruise control function off.

NOTE: When the joystick feed and up/down control is reversed and the left joystick is used to move the carriage forward/backward, the top right button on the right joystick is used for the cruise control function.

USING THE POWER FEED

1. To move the carriage forward, push the right joystick forward and adjust the feed rate.



HINT: To get a straight cut in the first part of the board, feed the blade into the log at a slow speed. This stops the blade from flexing and dipping up or down. Adjust the carriage feed rate to a slow speed until the whole width of the blade has entered the cut. Then push the joystick forward to increase the feed rate as desired. Maximum feed rate varies with width and hardness of the wood. Over-feeding results in engine and blade wear, and also produces a wavy cut.



2. Stop the carriage at the end of the cut by releasing the joystick. Push the blade on/off switch to stop the blade and drop the engine to idle. **Over-feeding may result in belt slippage and premature wear, and a poor cut.** During training period, till sawyer gets familiar with the sawmill, always disengage the blade at end of the cut. After this period run Tier 4 Final Diesel Engine at full speed to keep exhaust temperatures elevated. This will ensure proper regeneration cycles. Failure to do so will result in insufficient burn and clog up the soot filter causing repairs



CAUTION! Be sure to stop the blade when returning the carriage. This will not only prevent the blade from being pulled off and ruined by a wood sliver, but also will increase the life of the blade. [See Section 4.9](#) for optional sawing procedure

3. Make sure that the blade does not catch on the end of the log. Raise the carriage slightly to make sure the blade clears the log when returned. (Press the bottom button on the right joystick to use the bump-up feature to raise the cutting head by the size specified for bump-up. Default size is 5/8").
4. Return the carriage to the front of the mill by pulling the right joystick back. [See Section 4.9](#) for optional sawing procedure.



DANGER! Stay clear of the area between the trailer axle and saw carriage. Failure to do so will result in serious injury.

4.8 Control Operation

Display Overview

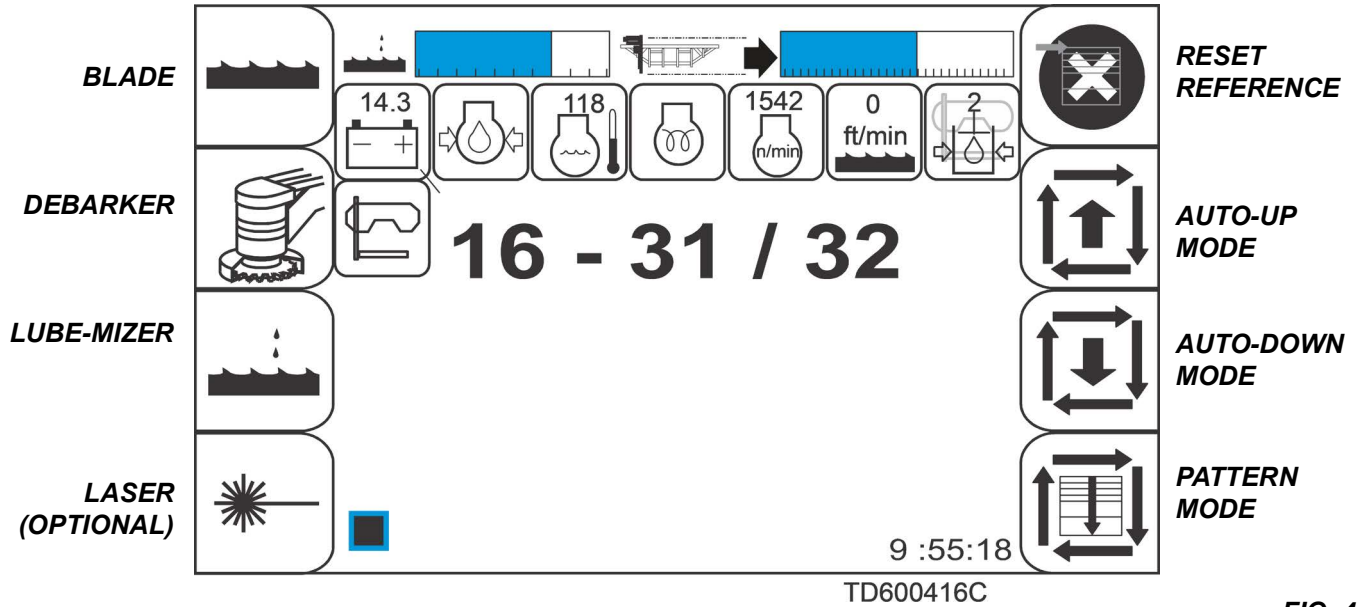

FIG. 4-10

	Battery Voltage		Head Mode
	Engine Oil Pressure (Icon turns red when there is no oil pressure.)		Bed Mode
	Engine Water Temperature (Icon turns yellow when temperature is between 215F-225F (102C-107C). Icon turns red when temperature is above 225F (107C))		Feed Speed Rate
	Cold Start Device (Icon indicates when air heater is running)		Blade Position
	Engine RPM		Active DTC (Diagnostic Trouble Code)
	Blade Speed		Time
	Head Manifold Hydraulic Pressure Indicator		

Configuration

The controls on new sawmills are configured at the factory. If you have installed or replaced the control, be sure to configure the control as described below before operating the sawmill.

To enter User Configuration screen, push the Configuration button. Turn the knob to select the configuration settings and push to enter.

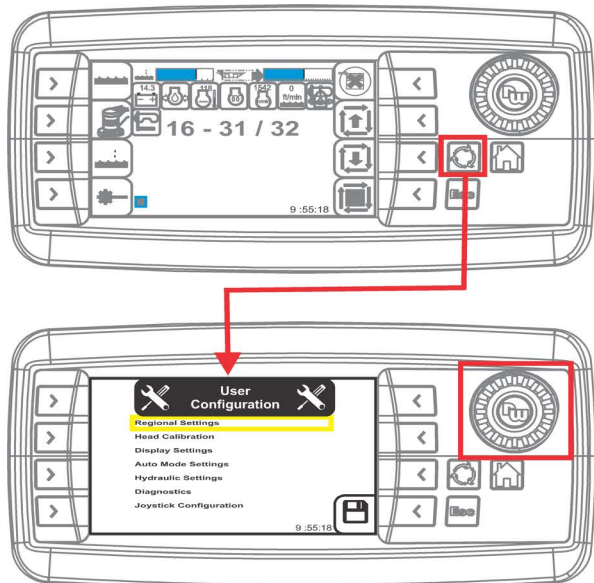

⚙️ **User Configuration** ⚙️

- Regional Settings**
- Head Calibration**
- Display Settings**
- Auto Mode Settings**
- Hydraulic Settings**
- Diagnostics**
- Joystick Configuration**

FIG. 4-11

Language

Selects the language (English is default). When in User Configuration menu, use the knob to select the Regional Settings menu. Push the knob to enter. Turn the knob to select the Language menu and push to enter. Use the knob to select the desired language to use for the display. Push the SAVE button to save the changes. Push the Configuration button to go to the User Configuration menu or the Home button to go to the Main screen.

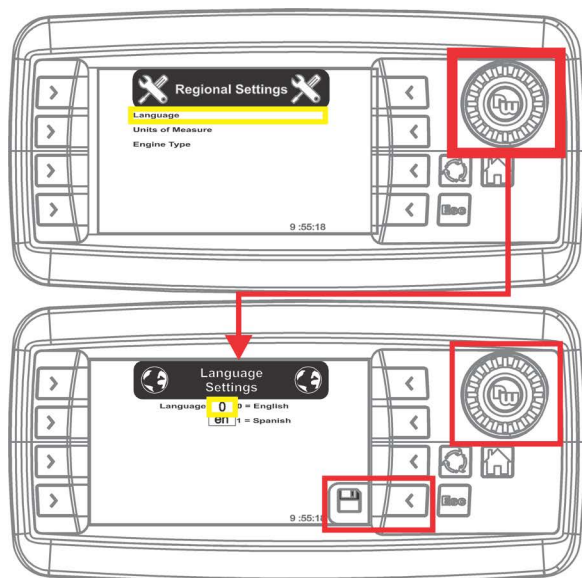

600419-2

⚙️ **Regional Settings** ⚙️

- Language**
- Units of Measure**
- Engine Type**

🌐 **Language Settings** 🌐

Language: 0 0 = English
en 1 = Spanish

FIG. 4-12

Unit of Measure

Selects the units of measure, temperature and pressure are used when operating the control (default units of measure are in inches and fractions; default temperature is Fahrenheit). From the Regional Settings menu, select Unit of Measure Settings and push the knob to enter. Turn and push the knob to select the setting. Use the knob to change the existing setting. Push the SAVE button to save the changes.

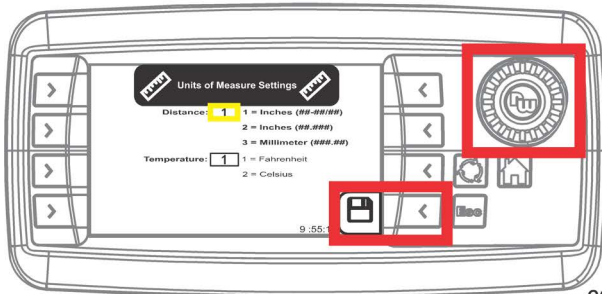

600419-3B

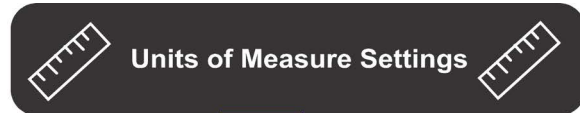

Distance: **1** 1 = Inches (##-##/##)
 2 = Inches (##.###)
 3 = Millimeter (###.##)

Temperature: **1** 1 = Fahrenheit
 2 = Celsius

FIG. 4-13

Engine Type

This menu allows you to choose the engine option used on the sawmill. From the User Configuration menu, select the Engine Type menu and push the knob to enter. Use the knob to select the engine type used on the sawmill. Push the SAVE button to save the changes.

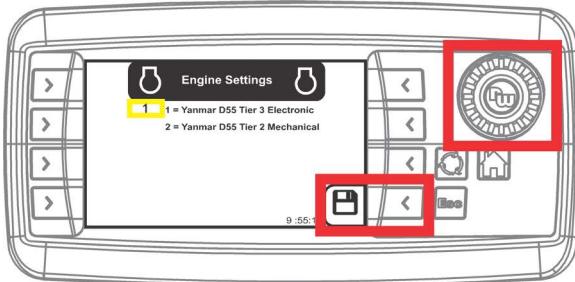

600419-5B



1 1 = Yanmar D55 Tier 3 Electronic
 2 = Yanmar D55 Tier 2 Mechanical

G. 4-14

Head Position Calibration

These settings allow to calibrate the cutting head, if necessary. These settings are made at the factory and, except for the kerf, should not normally need adjusting by the operator.

To enter the Head Position Calibration screen, push the Configuration button.

Turn the knob to select the Head Calibration and push to enter.

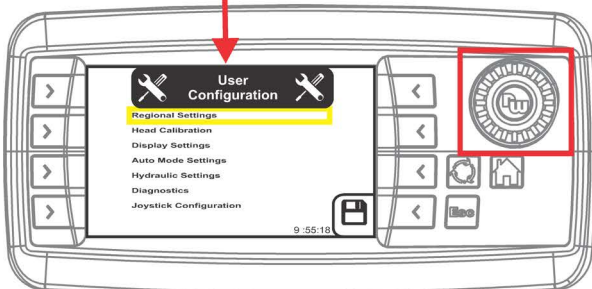
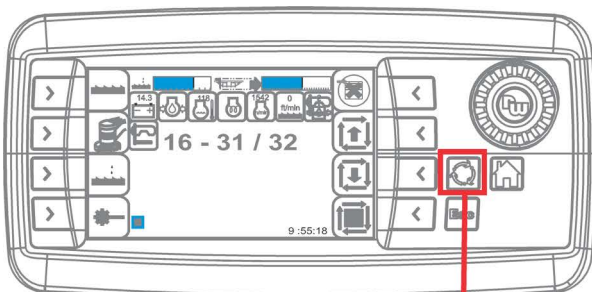

600419-10B



- Regional Settings
- Head Calibration**
- Display Settings
- Auto Mode Settings
- Hydraulic Settings
- Diagnostics
- Joystick Configuration

FIG. 4-15

- Position the head so the blade is directly over a bed rail.

NOTE: The head should be calibrated at 6" and 30", although these measurements need not be exact.

- Measure from the blade edge to the stand, not the bed rail.
- If measuring with a tape measure, use a calculator to convert your fractional dimension to decimals to the thousandth of an inch (0.001")
 - The closer the 2 values captured are, the more the error in reading the tape measure accurately will be transmitted throughout the travel of the head away from those 2 points.
- You can capture the upper and lower extents in any order you prefer, that will not matter.
 - If you select the wrong capture button, just press the correct one next, then go back and re-capture the position you messed up.

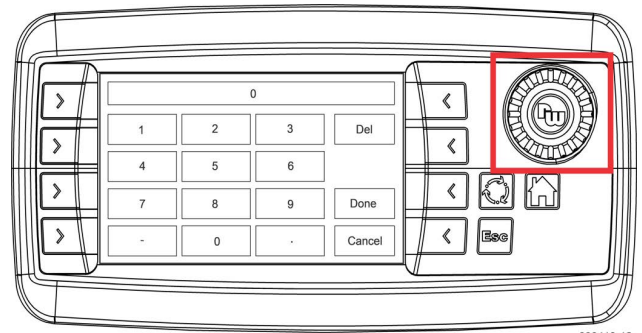

600419-12

FIG. 4-16

- Capture the lower extent.
- Lower the head to a position around 6" (it doesn't need to be exact).
- In the Head Calibration screen, enter the value measured as accurately as possible here. Use the Knob to navigate to the "Lower Calibration Position" numerical entry box, it will be highlighted yellow.
- Press the Knob to select it and open the keypad.
- If there is a value there, you will have to delete it first, then enter the head position as accurately as possible, press Done.
- Now press the "Lower Calibration Position Capture" button on the left.

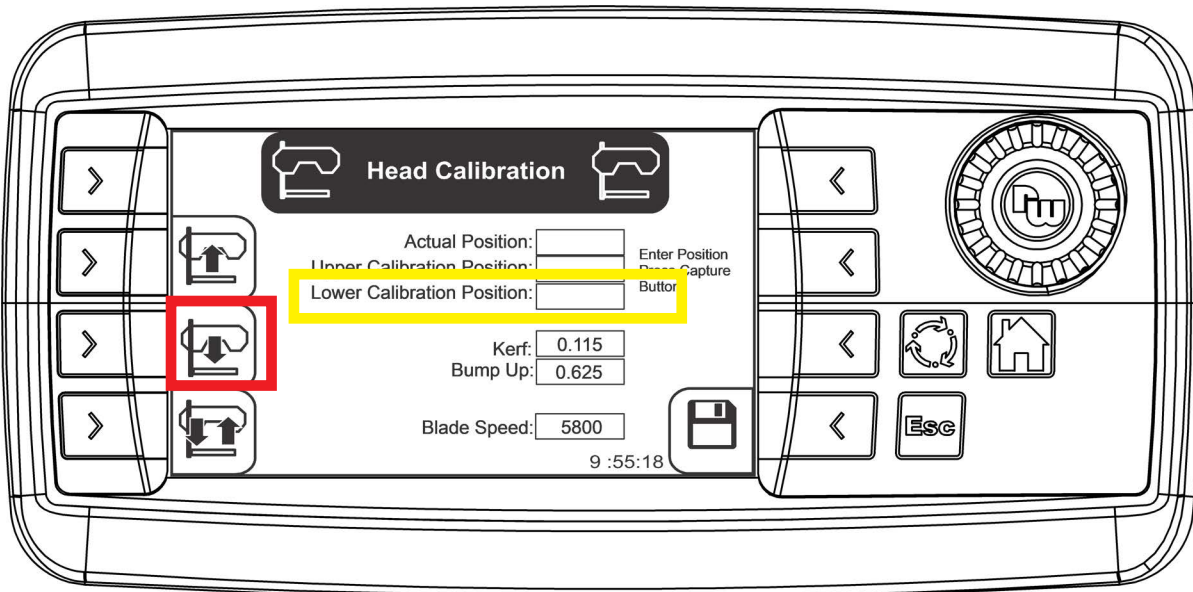
600419-18
FIG. 4-17

- Capture the upper extent.
- Raise the head to a position around 30" (it doesn't need to be exact).
- In the Head Calibration screen, enter the value measured as accurately as possible here. Use the Knob to navigate to the "Upper Calibration Position" numerical entry box, it will be highlighted yellow.
- Press the Knob to select it and open the keypad.
- If there is a value there, you will have to delete it first, then enter the head position as accurately as possible, press Done.

- Now press the “Upper Calibration Position Capture” button on the left.

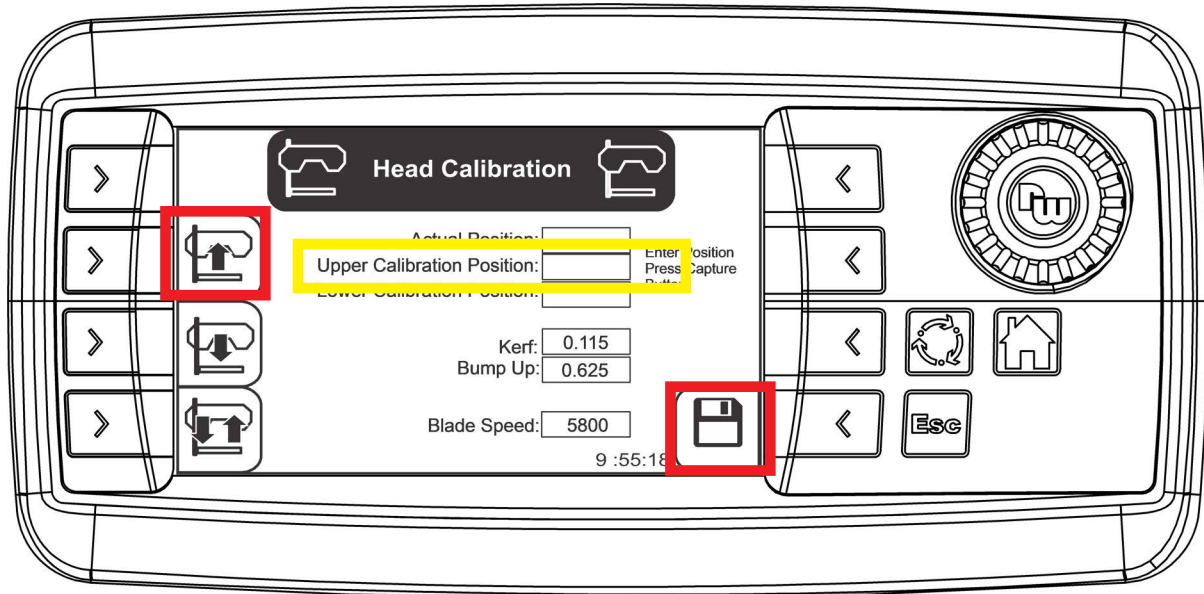

600419-18
FIG. 4-18

- Save the parameters by pressing the “Save” button on the lower right.

Display Settings

This menu allows you to adjust the clock time, date, power modes and backlight settings. From the User Configuration menu, select the Display Settings menu and push the knob to enter. Turn the knob to select and change the setting. Push the SAVE button to save the changes.

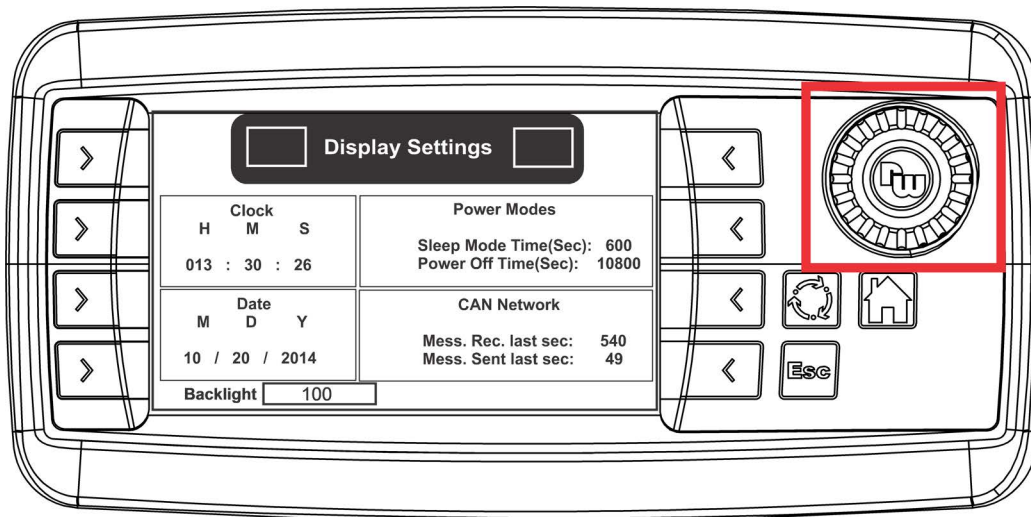

FIG. 4-19

600419-6

Auto Mode Settings

[See Section 4.9](#) for more information on the Auto Mode Settings.

Hydraulic Settings

From the User Configuration menu, select the Hydraulic Settings menu and push the knob to enter. The Hydraulic Settings menu allows you to change the speed of the Log Deck Option and toe board down movement. To change any of the settings, turn the knob to select the desired setting. Use the knob to change the setting as necessary. Push the SAVE button to save the changes.

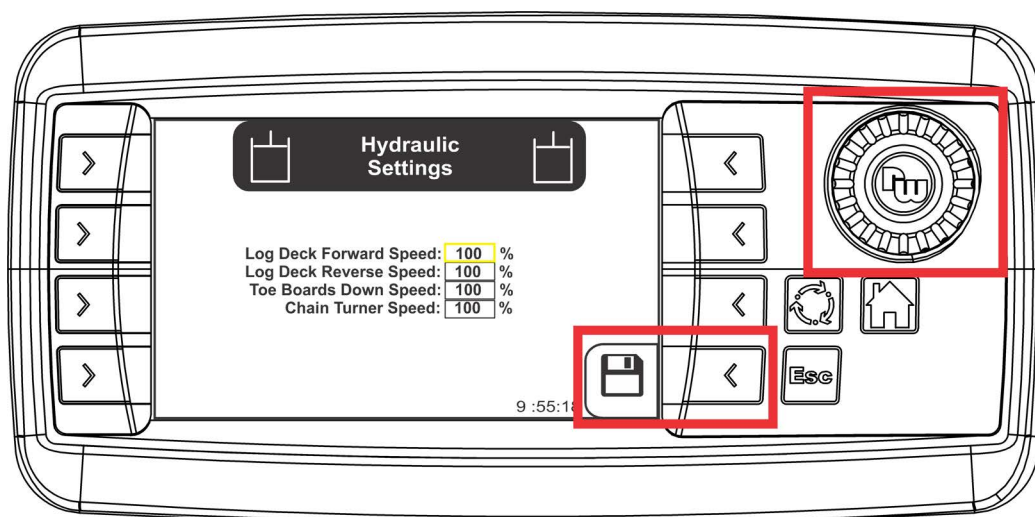

600419-7B **FIG. 4-20**

Diagnostics

The Diagnostics menu allows you to check the communication status of the sawmill head, bed, operator, engine and throttle. To enter the Diagnostics menu, select Diagnostics from the User Configuration menu. Push the Configuration button to exit.

Joystick Configuration

The Joystick Configuration menu allows you to change the joystick configuration, calibrate and troubleshoot the joystick controls.

To enter the Joystick Configuration menu, select Joystick Configuration from the User Configuration menu.

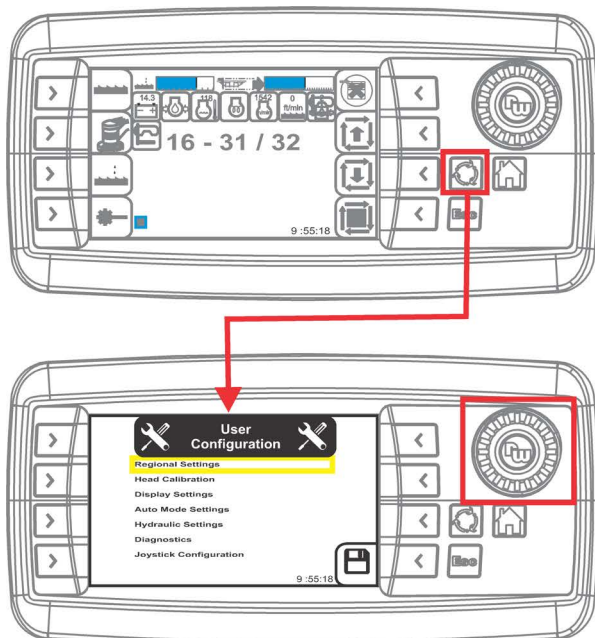

Regional Settings

Head Calibration

Display Settings

Auto Mode Settings

Hydraulic Settings

Diagnostics

Joystick Configuration

600419-14B

FIG. 4-21

CAPTURE JOYSTICK CENTERS AND SET DEADBAND WINDOW:

- On the Joystick Configuration screen, turn the knob until the on screen button for “Centering the Joysticks” is highlighted.

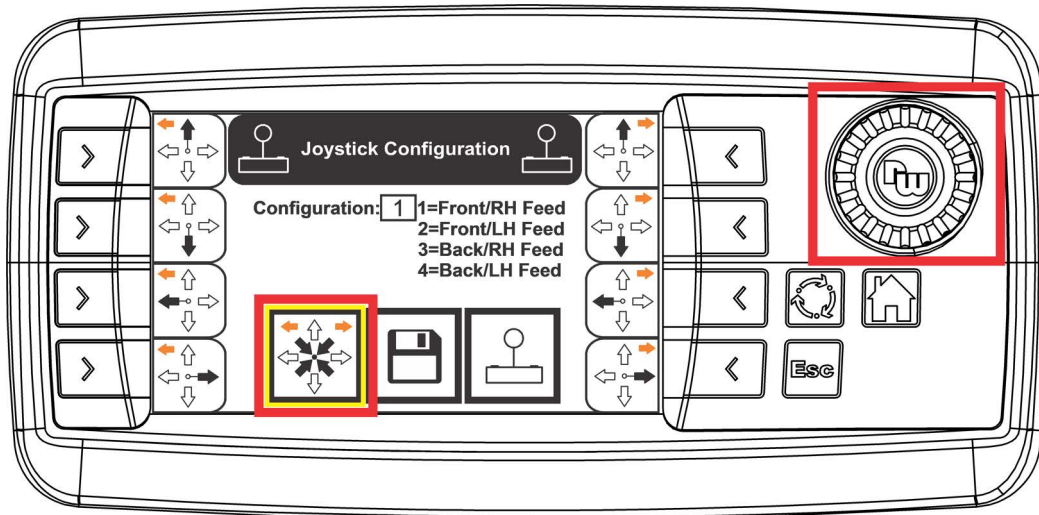

600419-15

FIG. 4-22

- Make sure the joysticks are resting in their upright position and centered.
- Press and release the knob to capture the center positions and set the dead band windows.

CAPTURE THE TRAVEL EXTENTS OF THE LEFT JOYSTICK:

- Push the left joystick base all the way forward and hold it in that position.
- Press and release the top left soft key to capture the forward limit of the left joystick. Wait 1 second then release the joystick.

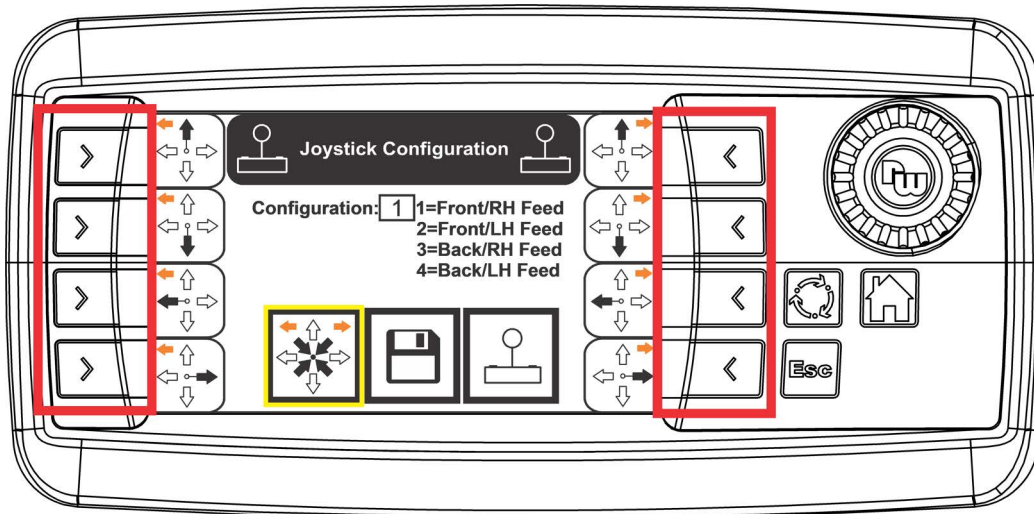

600419-16

FIG. 4-23

- Pull the left joystick base all the way backward and hold it in that position.
- Press and release the second from the top left soft key to capture the backward limit of the left joystick. Wait 1 second then release the joystick.
- Push the left joystick base all the way to the left and hold it in that position.
- Press and release the third from the top left soft key to capture the left limit of the left joystick. Wait 1 second then release the joystick.
- Pull the left joystick base all the way to the right and hold it in that position.
- Press and release the bottom left soft key, to capture the right limit of the left joystick. Wait 1 second then release the joystick.

CAPTURE THE TRAVEL EXTENTS OF THE RIGHT JOYSTICK:

- Push the right joystick base all the way forward and hold it in that position.
- Press and release the top right soft key to capture the forward limit of the right joystick. Wait 1 second then release the joystick.
- Pull the right joystick base all the way backward and hold it in that position.

- Press and release the second from the top right soft key to capture the backward limit of the right joystick. Wait 1 second then release the joystick.
- Pull the right joystick base all the way to the left and hold it in that position.
- Press and release the third from the top right soft key to capture the left limit of the right joystick. Wait 1 second then release the joystick.
- Push the right joystick base all the way to the right and hold it in that position.
- Press and release the bottom right soft key to capture the right limit of the right joystick. Wait 1 second then release the joystick.

SAVE THE PARAMETER CHANGES:

- Turn the knob until the middle SAVE button is highlighted.
- Press and release the knob to save the parameters.
- Press and release the “Home” button.

4.9 Auto-Setting Features

Mode Selection

Mode Select button (Auto-Down, Auto-Up or Pattern) are located on the right side of the display. The Manual Mode is the default mode when no mode is selected. The Manual Mode operates the up/down functions of the sawmill without any Auto-Set features.

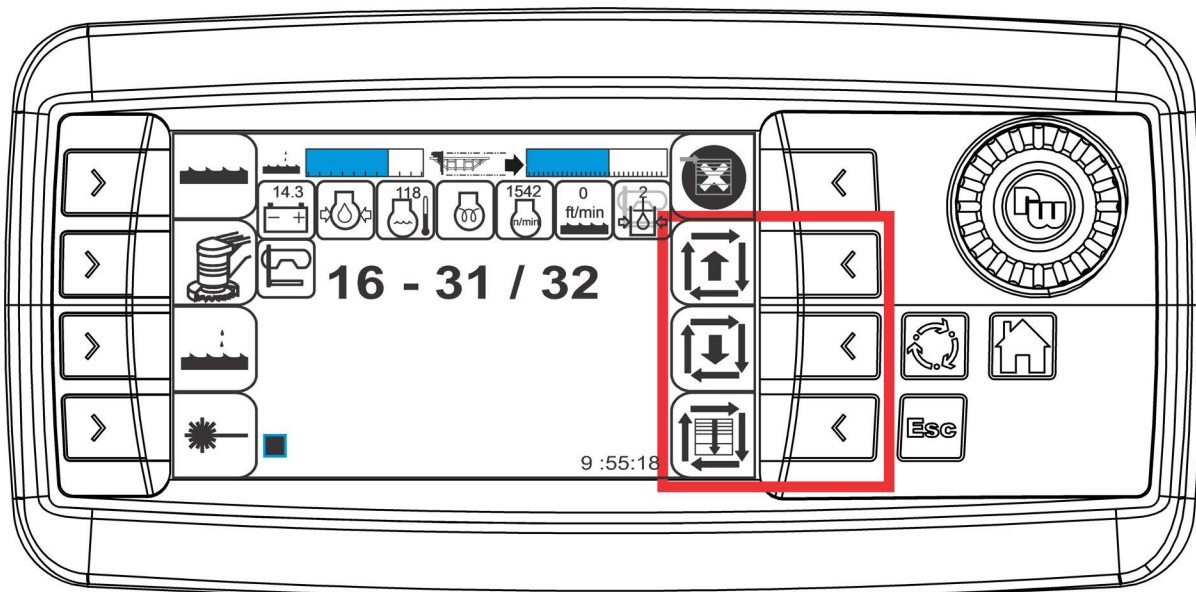

FIG. 4-24
600719-9C



Auto-Up Mode - This mode *references the current blade height* and allows you to choose an increment to move the blade *up*. The system will automatically move the saw head up and stop at the next increment when you press the right joystick trigger switch to initiate a set. Auto-Up mode is primarily used to raise the saw head in large increments when preparing to cut a new log or log that has been turned. This allows the operator to raise the saw head without having to hold the joystick up, freeing the operator to perform other functions while the saw head is being raised.



Auto-Down Mode - This mode *references the current blade height* and allows you to choose an increment to move the blade *down*. The control system will automatically move the saw head down and stop at the next increment when you press the right joystick trigger switch to initiate a set. You can store sixteen different increment levels.



Pattern Mode - This mode *references the bed surface* and allows you to program up to six different increments calculated up from the bed. The sixth (top) increment repeats itself up to the upper limit of the saw head travel. The bottom increment indicates the size of the remaining cant when the pattern is complete.

All the Auto-Down, Auto-Up and Pattern Modes settings can be adjusted through the Auto Mode Settings menu. See [See Auto-Mode Settings Menu](#) below for more information.

Using Auto-Down Mode

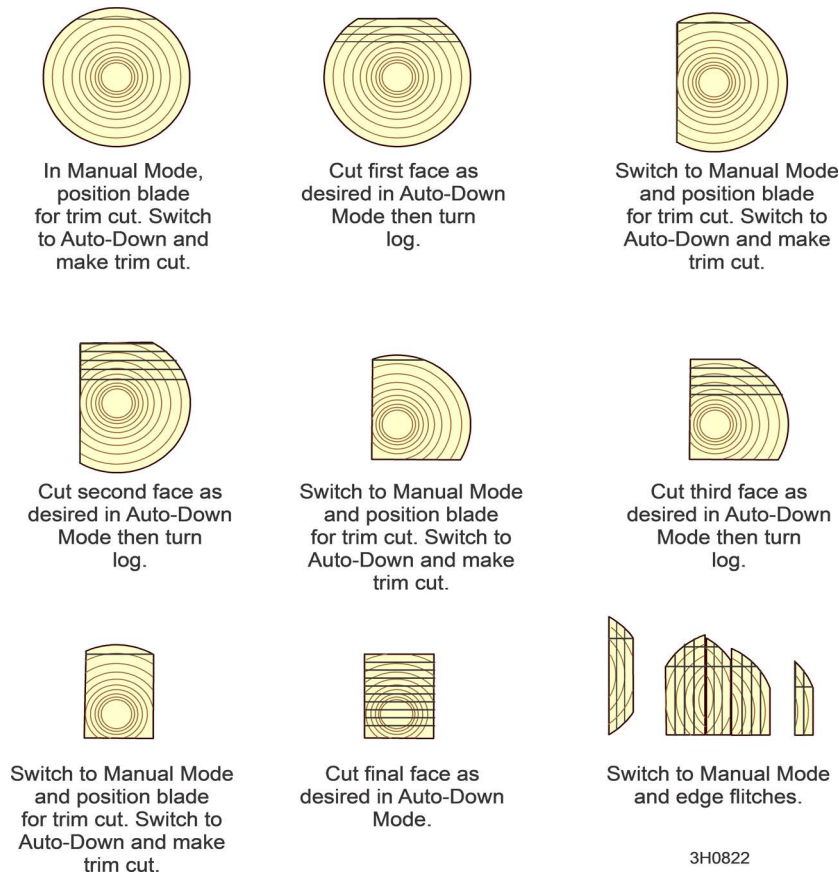
**FIG. 4-25**

- Starting with a new log, position the saw head to make the first trim cut.
- Push the Auto-Down button on the right side of the display. The first increment setting is displayed by default.
- Choose the desired increment setting by pushing the appropriate increment setting button.
- Change an increment setting in the Auto-Mode Settings screen by selecting the desired setting number and push the knob.
- Turn the knob until the desired increment setting is obtained.

NOTE: If the kerf is changed to “0” in the Head Calibration Screen, it is necessary to include blade kerf in your setting (i.e. If you want the finished boards to be 1" thick, set the increment to 1 1/8" to allow for typical blade kerf.). The amount of kerf will depend on the thickness and tooth set of the blade you are using. The system can be programmed with an automatic kerf setting if desired (The default kerf is set to 0.115”).

- Push the SAVE button to store the value. (See [See Auto-Mode Settings Menu](#) below for more information on how to adjust the increment settings using the Auto-Mode Settings Menu.)
- Push the Auto-Down button to return to Auto-Down Mode if necessary.
- Make the trim cut, raise the saw head (use Bump-Up) and return the carriage to the front of the log.
- Use the trigger switch on the right joystick to initiate a set.

The saw head will automatically bypass the setting where the first cut was made and stop at the next setting determined by the increment you have chosen.

- Make a cut, raise the saw head (use Bump-Up) and return the carriage for the next cut.
- Use the trigger switch on the right joystick to initiate a set.

The saw head will stop at the setting for the next cut. Repeat this procedure down this face of the log as desired.

12. Turn the log as you normally would and push the Manual Mode button to place the control system in Manual Mode.
13. Position the saw head for the trim cut and push the Auto-Down button to return to Auto-Down Mode.
14. Make the trim cut, raise the saw head and return for the next cut.
15. Use the same procedure as described above to cut each side of the log until done.

NOTE: Anytime a trim cut is necessary, you can push the Manual button to enter Manual Mode. Position the saw head for the trim cut and push the Auto-Down button to return to Auto-Down Mode. The control system will reference the new blade position and stop at the next setting determined by the increment you have chosen.

Using Auto-Up Mode

Auto-Up Mode works exactly the same as Auto-Down explained above except it controls the saw head movement in the up direction.

Using Pattern Mode

1. Position the saw head at the front end of the log.
2. Push the Pattern button on the right side of the display.
3. Choose the desired pattern setting by pushing the appropriate Increment Setting button.

In Pattern mode, a list of six increments is shown on the display. These increments are referenced from the bed rail. The bottom increment represents the distance from the bed rail for the last cut. Each increment in the list can be adjusted as desired. The top increment repeats as necessary depending on how high you raise the saw head. See [See Auto-Mode Settings Menu](#) below for more information on how to adjust the pattern increment settings using the Auto-Mode Settings Menu.

4. Push the Manual Mode button and raise the saw head so the blade is positioned near the top of the log.
5. Push the Pattern button to return to Pattern Mode.
6. Use the trigger switch on the right joystick to initiate a set.

The saw head will automatically stop at the first setting determined by the top pattern increment.

7. Make a cut, raise the saw head (use Bump-Up), and return the carriage for the next cut.
8. Use the trigger switch on the right joystick to initiate a set.

The saw head will stop at the setting for the next cut.

9. Repeat this procedure down this face of the log as desired.

NOTE: The first push of the joystick trigger sets the head "on scale" to produce consistent increments from the bed rails up to the current location. Therefore, the first drop after entering the Pattern Mode may not be the thickness programmed.

10. Turn the log as you normally would and push the Manual Mode button to place the control system in Manual Mode.
11. Raise the saw head so the blade is positioned near the top of the log and push the Pattern button to return to Pattern Mode.
12. Make the cut, raise the saw head (use Bump-Up) and return for the next cut.
13. Use the same procedure as described above to cut each side of the log until done.

Auto-Mode Settings Menu

The control system setups all the necessary auto-up/auto-down, pattern, and reference settings by using the Auto-Mode Settings Menu. From the Main screen, enter the User Configuration menu by pressing the Configuration button on the right side of the display. Use the knob to highlight the Auto-Mode Settings. Press the knob to enter the Auto Mode Settings menu.

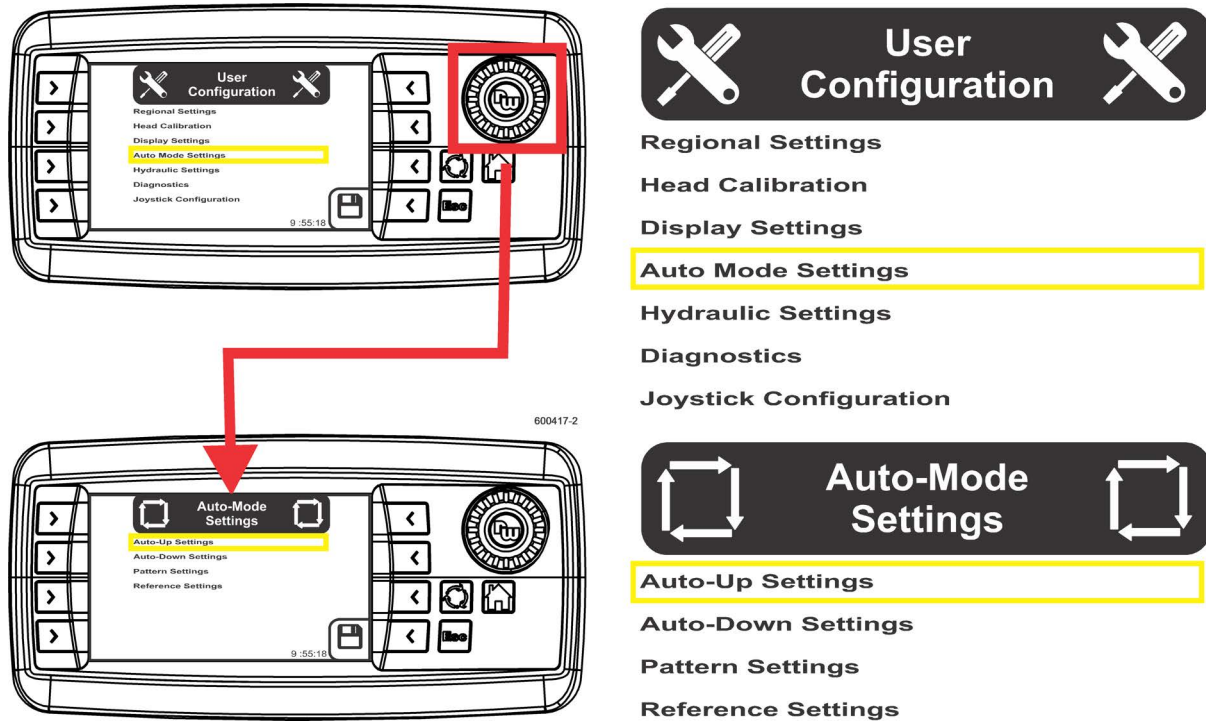

FIG. 4-26

AUTO-UP SETTINGS.

1. Select the Auto-Up Settings from the Auto Mode Settings menu to enter the Auto-Up Settings screen.
2. Use the Increment Settings buttons to choose settings 1, 2, 3 or 4.
3. Turn the knob to highlight the settings you want to adjust.
4. Press and turn the knob to adjust the setting.
5. Press the SAVE button to save the settings.

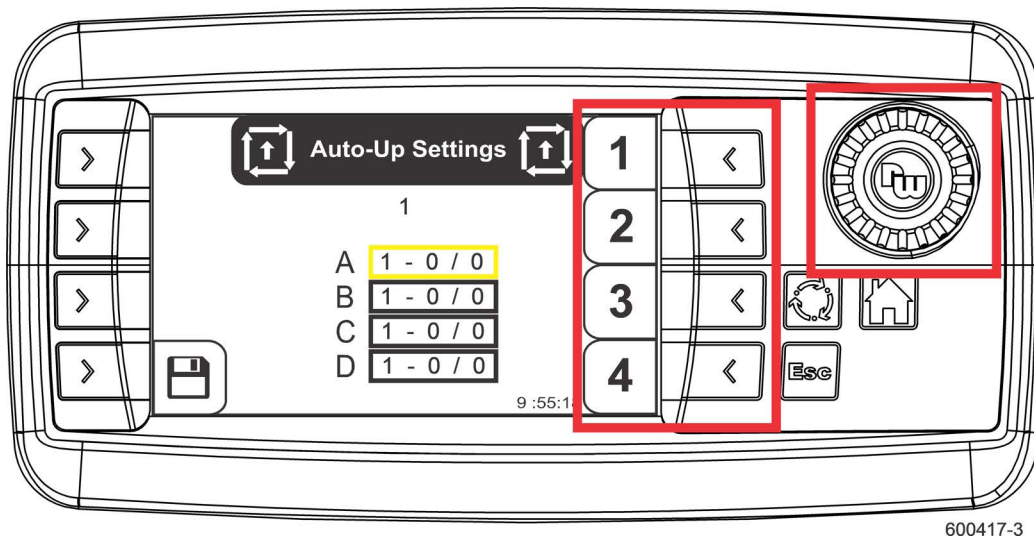

FIG. 4-27

AUTO-DOWN SETTINGS.

1. Select the Auto-Down Settings from the Auto Mode Menu to adjust the Auto-Down Settings.
2. Repeat the steps for Auto-Up described above.

PATTERN SETTINGS.

1. Press the Pattern 1 button to display the Pattern 1 Settings.
2. Press the Pattern 1 button again to change between settings A, B, C or D.
3. Use the knob to adjust the setting.
4. Press the SAVE button to save the settings.

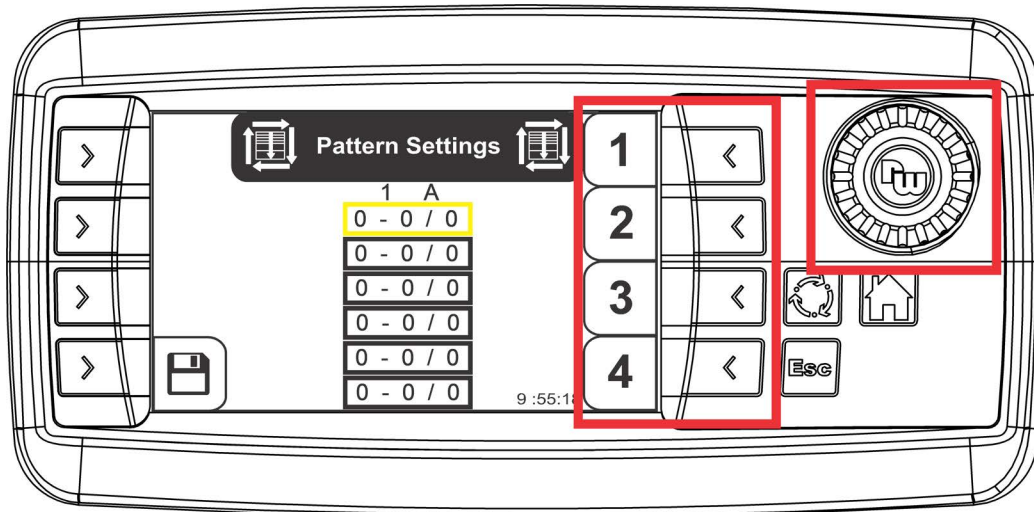

600417-4

FIG. 4-28

5. Select and adjust the Pattern 2, 3, and 4 Settings the same way as described for Pattern 1 Settings.

REFERENCE SETTINGS.

1. Select the Reference Settings from the Auto Mode Settings menu to enter the Reference Settings menu. (**NOTE:** These reference settings are fixed. It is also possible to set temporary reference settings while in Auto-Mode.)
2. Use the knob to highlight the settings you want to adjust.
3. Press and turn the knob to adjust the setting.
4. Press the SAVE button to save the settings.

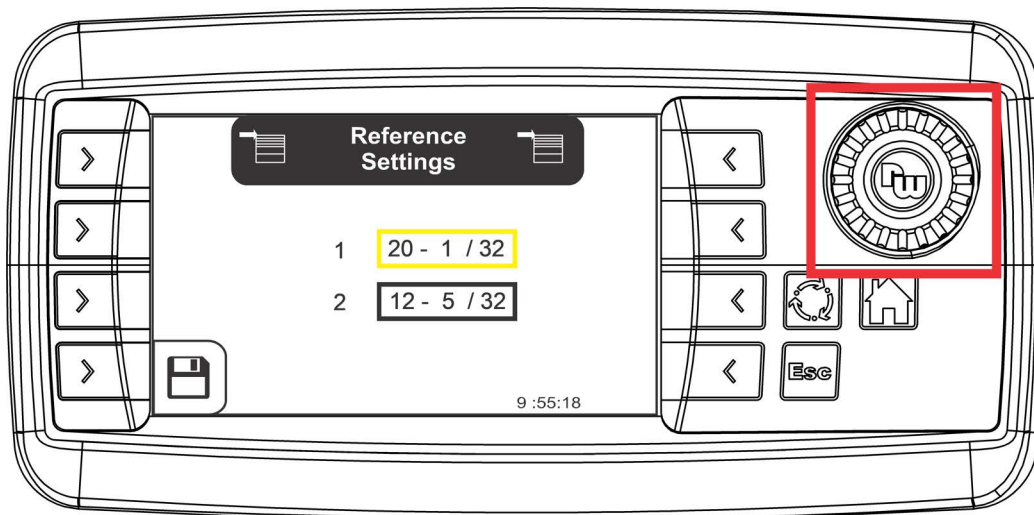

600417-5

FIG. 4-29

Joystick Auto-Mode Operation

1. Use the left and right joysticks to switch to the desired auto-mode setting.
2. Press the top left button on the left joystick to toggle between Manual Mode and the most recently used auto-mode setting.
3. Press the top left button on the right joystick while in Manual Mode to go to Reference 1 setting.
4. Press the top right button on the right joystick while in Manual Mode to go to Reference 2 setting.
5. Use the right joystick trigger switch to set the cutting head.
6. Press the top left button on the right joystick while in Auto-Mode to set the current head position as Reference 1.
7. Press the top right button on the right joystick to set the current head position as Reference 2.

NOTE: This procedure sets Temporary Reference values for Reference 1 and 2. If these values are different than 0 and you are in manual mode, press a reference button for the temporary reference setting. The temporary references can be cleared with the Temporary Reference Clear button (X) on the manual mode screen.

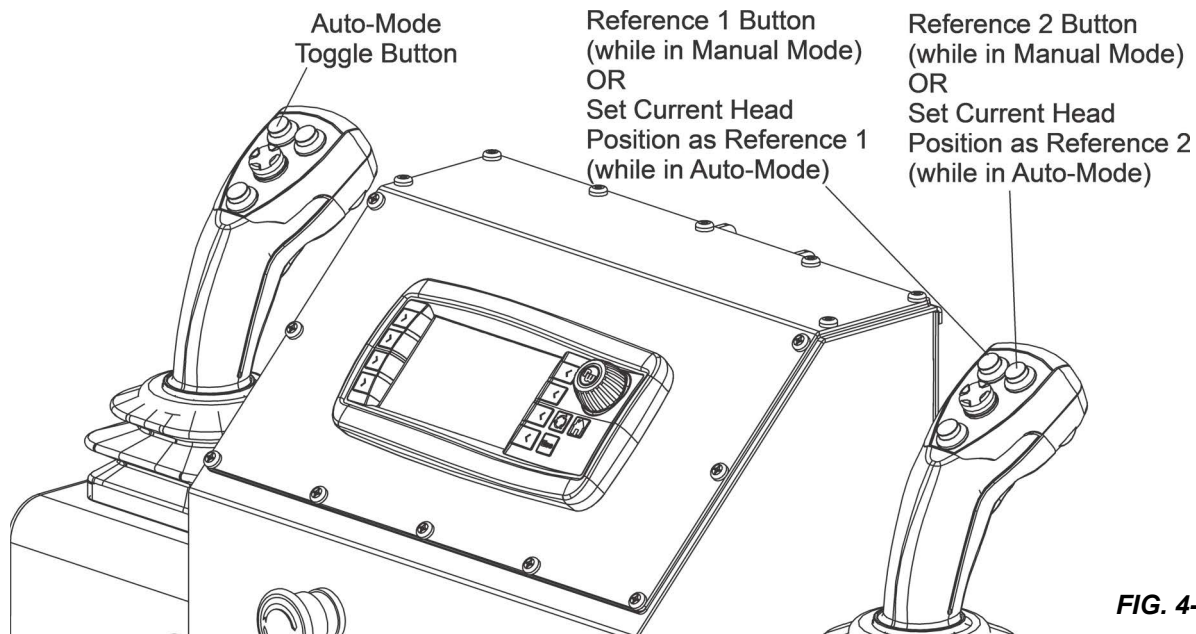

FIG. 4-30

4.10 Cutting The Log

The following steps guide you through normal operation of the Wood-Mizer sawmill.

1. Once the log is placed where you want it and clamped firmly, move the saw head to position the blade close to the end of the log.
2. Set the blade to the desired height with the left joystick. Make sure that the blade will clear all side supports and the clamp. Adjust the outer blade guide to clear the widest section of the log by using the left joystick 4-way switch.



NOTE: An optional laser sight is available to help determine where the blade will travel through the log. See the laser sight manual for detailed operating instructions.



3. Push the blade on/off button to start the blade spinning.

4. Start the water lube if necessary to prevent sap buildup on the blade. [See Section 4.11.](#)
5. Push the right joystick forward to feed the blade into the log slowly ([See Section 4.6.](#)).

NOTE: Once the blade completely enters the log, push the joystick forward to increase the feed rate as desired. Always try to cut at the fastest speed you can while keeping an accurate cut. Cutting too slowly will waste blade life and lower production!

6. Slow down the feed rate as you get to the end of the log.
7. When the teeth exit the end of the log, stop the carriage.
8. Push the blade on/off button to stop the blade.
9. Raise the cutting head (use Bump-Up) and pull the right joystick back to return the carriage to the front of the mill.
10. Repeat until the first side of the log is cut as desired.
11. Set aside the usable flitches (boards with bark on one or both sides) for later milling.
12. Lower the toe boards, if they were used.
13. Use the joysticks in bed mode to release the clamp and engage the log turner.
14. Turn the log 90 or 180 degrees.
15. Make sure the flat on the log is placed flat against side supports if turned 90 degrees.
16. Make sure it is placed on bed rails if turned 180 degrees.
17. If the log was turned 90 degrees and you are using the toe boards to compensate for taper in the log, raise the front or rear toe board again on the second side of the log until the heart is parallel with the bed.
18. Repeat the steps used to cut the first side of the log until the log is square.
19. Cut boards from the remaining cant by adjusting the blade height for the thickness of boards that you want.

Example: For 1" (25.4 mm) thick boards, lower the carriage 1-1/16 - 1-1/8" (27-28.6 mm) for each board to allow for a 1/16 - 1/8" (1.6-3.2 mm) wide kerf.

4.11 Edging

1. Raise the side supports to 1/2 the height of the flitches, or the boards that need to be edged.
2. Stack the flitches on edge against the side supports.
3. Clamp the flitches against the side supports halfway up the flitch height.

TIP: Wider flitches should be placed to the clamp side. When they are edged, flip them over to edge the second side without disturbing the other flitches or without having to pull them from the middle of the stack.

4. Adjust the blade height to edge a few of the widest boards.
5. Loosen the clamp and turn the edged boards over to edge the other side.
6. Repeat steps 2-4.
7. Loosen the clamp and remove the boards that have good clean edges on both sides.
8. Clamp the remaining flitches and repeat steps 2-5.

4.12 Optional Cutting Procedure

In order to achieve maximum production rates, it may be desirable to leave the blade engaged when returning the carriage. (Normal operation procedures recommend disengaging the blade before returning the carriage for maximum blade life and fuel economy.)



DANGER! If leaving the blade engaged for maximum production rates, make sure the off-bearer stays out of the path of the blade.



CAUTION! If you choose to leave the blade engaged; raise the blade to clear the log before returning the carriage. Failure to do so may cause damage to the blade and/or sawmill.

4.13 Water Lube Operation

The Water Lube System keeps the blade clean. Water flows from a 5-gallon (18.9 liter) bottle through a hose to the blade guide where the blade enters the log. A valve in the bottle cap controls the amount of water flow.

Not all types of wood require the use of the Water Lube System. When it is needed, use just enough water to keep the blade clean. This saves water, and lowers the risk of staining the boards with water. Usual flow will be 1-2 gallons (3.8-7.6 liters) per hour.

Before removing the blade, engage the blade. Let the blade spin with water running on it for about 15 seconds. This will clean the blade of sap buildup. Wipe the blade dry with a rag before storing or sharpening.

For further lubrication benefits, add one 12oz. (0.35L) bottle of Wood-Mizer Lube Additive to 5 gallons (18.9 liters) of water. Wood-Mizer Lube Additive enables some previously impossible timbers to be cut by significantly reducing resin buildup on the blade. It helps to reduce heat buildup, wavy cuts, and blade noise. This biodegradable and environmentally friendly pre-mix includes a water softener additive, so it works with hard water.

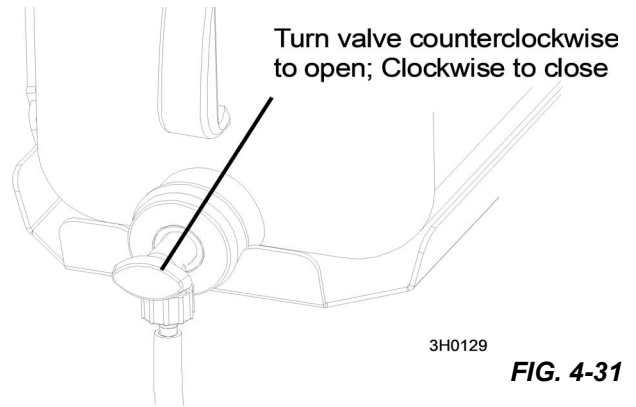

FIG. 4-31



WARNING! Use ONLY water and Wood-Mizer Lube Additive with the water lube accessory. Never use flammable fuels or liquids such as diesel fuel. If these types of liquids are necessary to clean the blade, remove it and clean with a rag. Failure to do so can damage the equipment and may result in serious injury or death.



CAUTION! Use windshield washer fluid to the water tank and prime as recommended when sawing or storing the sawmill in below-freezing temperatures. Use windshield washer fluid with a freezing point of at least -20°F (-29°C). Failure to do so may cause damage to the LubeMizer system.

To start the lube system, follow the instructions bellow

1. Press 3rd left soft button to turn on the lube mizer.

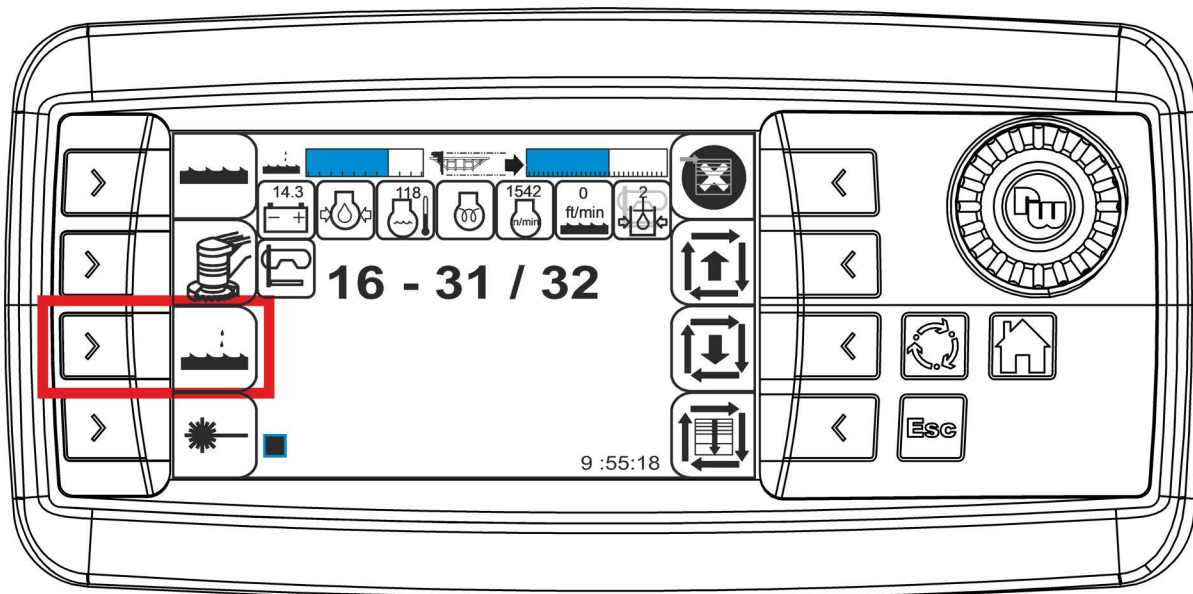

600419-9D

- Turn the knob till the lube adjustment display is highlighted in yellow.

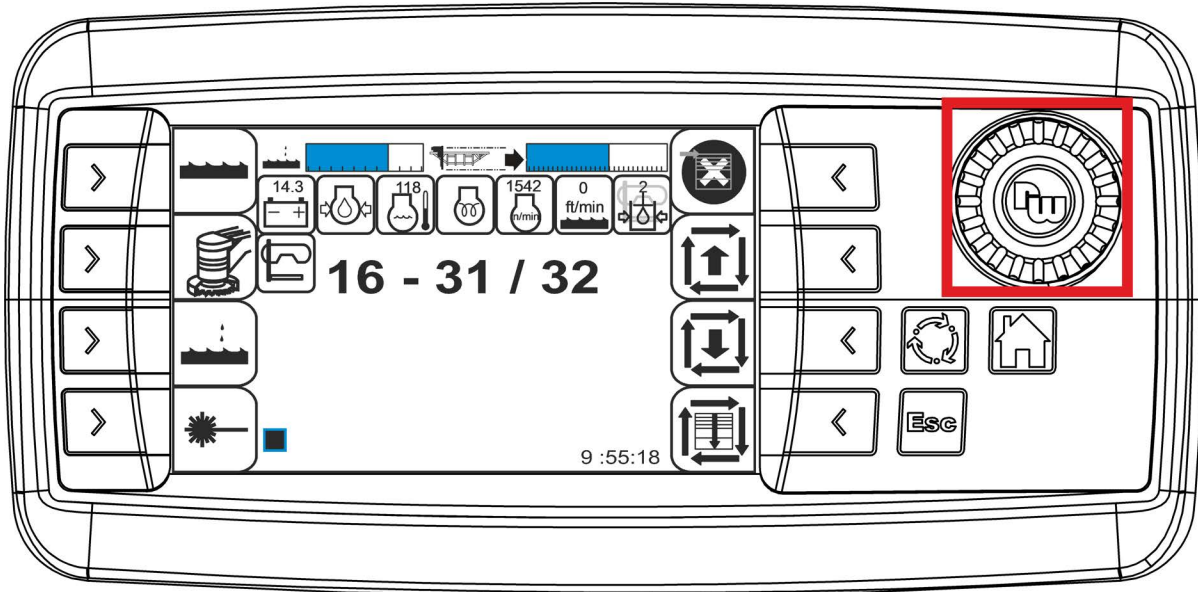

600419-9E

- Push the knob to highlight in green.
- Adjust to either slow pulse or fast pulse.
- Once adjusted press knob again green highlight turns yellow.

NOTE: Softwood applications will usually require more lubricant than hardwood applications. While the saw head is in motion, adjusting the pulse flow is possible, but the changes will not be visible on the spray pattern at the nozzles. The pump only activates in the forward direction.

4.14 Preparing The Sawmill For Towing

The Wood-Mizer trailer package makes transporting your sawmill easy and convenient.

- Move the saw carriage to the front end of the sawmill.
- Raise the rear outriggers. (See the Fine Adjust Outrigger (FAO) manual for outrigger operation instructions.)
- Move the log clamp all the way in toward the main bed frame tube.
- Use the hydraulic controls to raise the log turner and loader as high as they will go.
- Manually lift the loader and hook the loader chain to the turner.
- Use the hydraulic controls to lower the turner until the chain is tight.
- Push the loader lever down to bring the loader arm channels up to the loader.

- Remove the bed rail travel clamps from the rest pin.

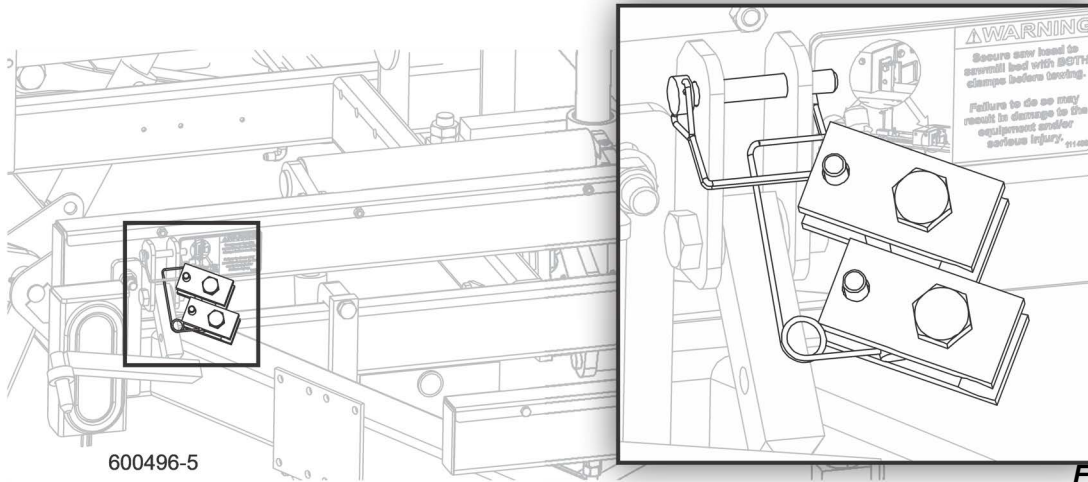

- Secure the rest pin in the vertical position with the locking pin.
- Move the carriage forward to the travel position over the rear bed rail.

NOTICE Do not move the saw head beyond the travel position. Damage to the equipment may occur.

- Position the hole in the saw head over the travel rest pin.
- Lower the saw head until it is seated firmly on the rest pin.
- Continue lowering the head 3/4" (19mm) until it contacts the stop block at the bottom of the mast.

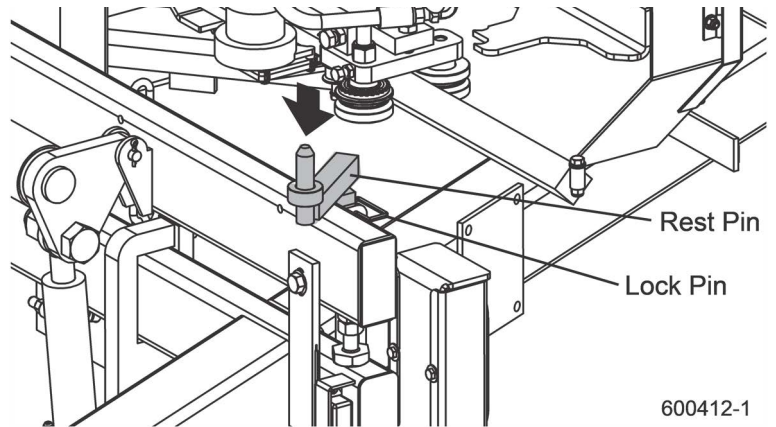

CAUTION! It is important that the lower stop bolt is properly adjusted to secure the carriage on the track rail. Failure to properly adjust the stop bolt can cause saw head damage, especially during mill transportation.

- If necessary, adjust the stop located at the bottom of the mast so the saw head contacts the stop after it is lowered 3/4" (19mm) past where it contacts the rest pin.
- Disconnect the cable from the back of the control box.

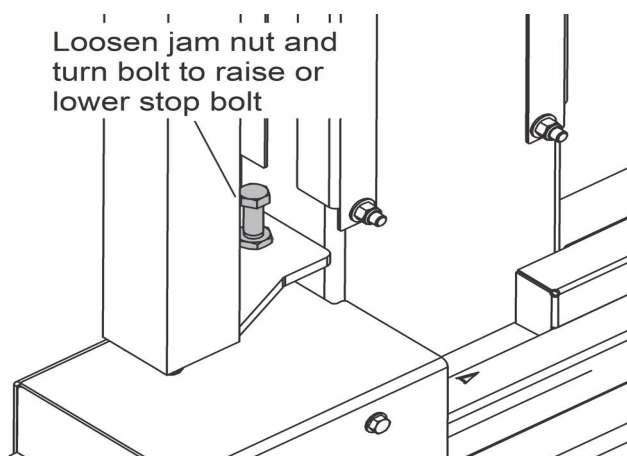

16. Place a bed rail travel clamp in front and behind the mast roller assembly.
17. Tighten the clamp to prevent any movement of the saw head along the rail.
18. Remove the locking pin holding the control box to the stand.
19. Lift the control box from the stand and place on the travel bracket on the sawmill frame.
20. Use the locking pin to secure the control box to the travel bracket.
21. Place the stand on the second travel bracket and secure with the remaining locking pin.

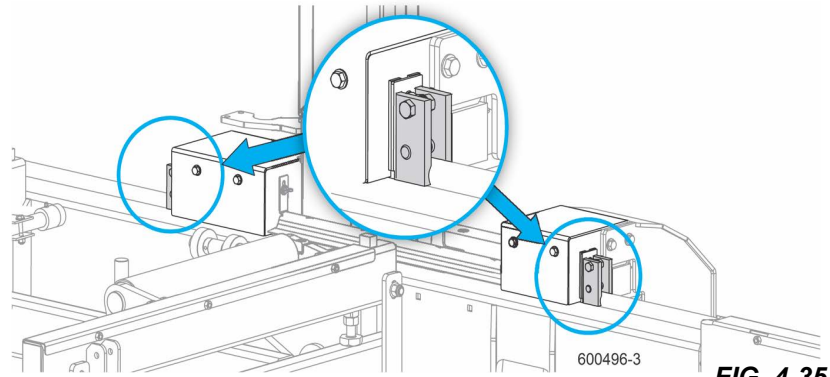
**FIG. 4-35**

22. Hook the carriage safety chain located at the bottom of the carriage to the bracket at the bottom of the mast.



CAUTION! Check to be sure the saw head safety chain is secured before towing the sawmill. Failure to properly secure the saw head can result in severe machine damage. Be sure the blade housing and pulley covers are in place and secure. Use the safety retainer pin and cable to fasten blade housing covers.

23. Remove all loose objects from the bed of the mill. Store the outrigger jack handle in the bracket provided on the front/loading-side outrigger guide.
24. Place the board return table in the towing position on the sawmill. Reverse the setup procedure described in Section 3.2 Portable Sawmill Setup. Be sure to secure the table to the frame with the retaining pins.

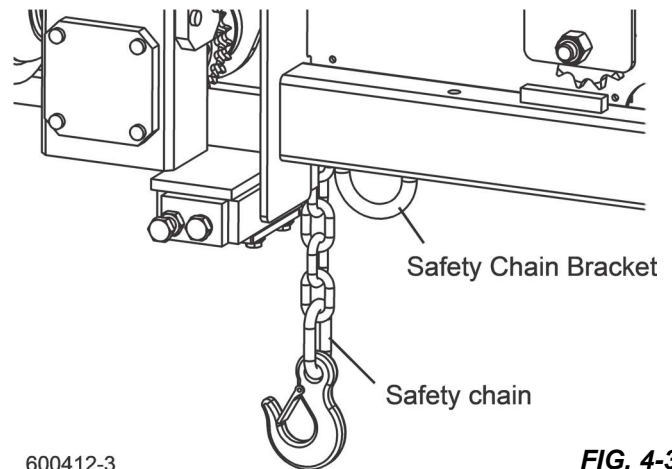
**FIG. 4-36**

WARNING! Secure the board return table to the sawmill bed before towing. Failure to do so may result in damage to the equipment and/or serious injury.

25. Place both fenders in the slots located behind the trailer tires and secure with rubber straps. Raise all but the very front outrigger (See FAO manual).

See the trailer operator's manual for specific information regarding hitch operation and towing the sawmill.

SECTION 5 MAINTENANCE

See the [Maintenance Log](#) located after this section for a complete list of maintenance procedures and intervals. Keep track of machine maintenance by filling in the machine hours and the date you perform each procedure.

Refer to option and engine manuals for other maintenance procedures.

5.1 Wear Life

This chart lists estimated life expectancy of common replacement parts if proper maintenance and operation procedures are followed. ***Due to the many variables which exist during a sawmill operation, actual part life may vary significantly.*** This information is provided so that you may plan ahead in ordering replacement parts.

Part Description	Estimated Life
Blade Wheel Belts	400 hours
Drive Belt	1250 hours

TABLE 5-1

5.2 Blade Guides



WARNING! Blade guide alignment is essential for optimal cutting performance, blade life, and safety. Failure to check and maintain proper blade guide alignment will result in stress cracks forming in the blade. These cracks will lead to premature blade breakage. If the blade breaks during operation and the blade has multiple stress cracks, the blade could shatter into several pieces and escape from the protective guards of the sawmill. Small blade pieces projected into the area around the sawmill creates a safety hazard for the operator and any bystanders surrounding the mill

Before performing service near moving parts such as blades, pulleys, motors, belts and chains, first turn the key switch to the OFF (#0) position and remove the key. If the key is turned on and moving parts activated, serious injury may result.

1. Check the rollers for performance and wear every blade change.
2. Make sure the rollers are clean and spinning freely -- if not, replace them.
3. Replace any rollers which have worn smooth or have become cone shaped.
4. Inspect the blocks at every blade change for damage or wear.
5. If the block housing is bent or damaged, replace the block assembly.
6. Replace the block assemblies before the blocks are worn to a point the blade may contact the lower step or housing.
7. Check the guide blocks with the provided shim or a feeler gauge **every 25 hours** of operation to ensure they are properly spaced (.008" - .010") from the blade.

NOTE: As the blocks wear, the front inside corner will wear more than the body of the block. When the corner wears far enough, sawing performance will be affected even if the body of the block is adjusted properly to the blade. At this point, the block should be replaced. If you have access to the appropriate equipment, you can grind or mill the blocks to a new flat surface and reuse them. It is recommended you develop a routine schedule for replacing the blade guide blocks based on your sawing conditions and experience.

8. Loosen the clamp bolt and mounting bolt to adjust the top block down.
9. Turn the adjustment bolt clockwise.
10. Retighten the mounting bolt and clamp bolt.
11. To adjust the bottom block up, loosen the clamp bolt and mounting bolt.
12. Use the provided adjustment tool to turn the adjustment screw clockwise.
13. Retighten the mounting bolt and clamp bolt.

NOTICE The blocks should be parallel to the blade. [See Section 7.2](#) for instructions about checking and adjusting the assembly level with the blade.

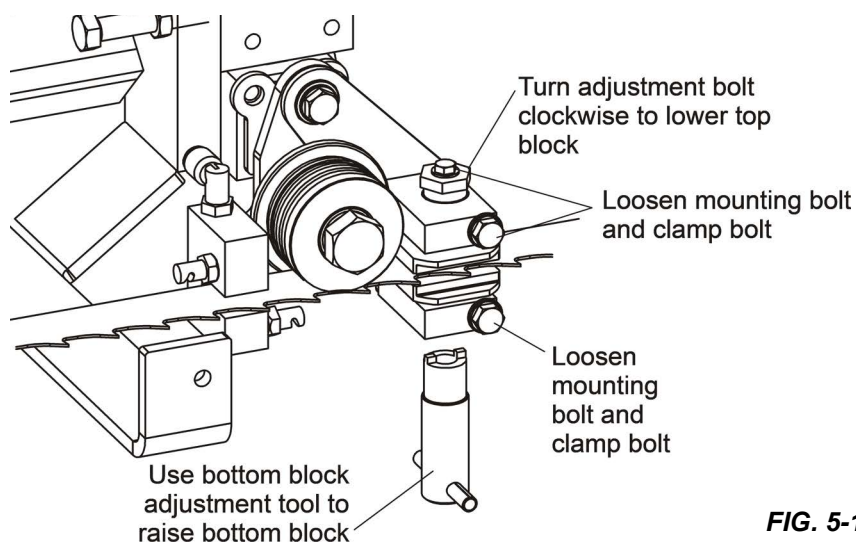

FIG. 5-1

Preventing sap buildup on the blade is critical when using the high-performance blade guide system. If the wood you are sawing leaves sap buildup using plain water in the blade lube system, use Wood-Mizer lube additive (4-Pak 60 oz. bottles part no. ADD-1).

14. Make sure the blade screw in the top center of the C-frame is 1/16" (1.5 mm) away from the blade; if not, loosen the nut and adjust the screw as necessary.

15. Check the screw **every 500 hours** of operation.

Failing to maintain this adjustment will lead to early blade breakage.

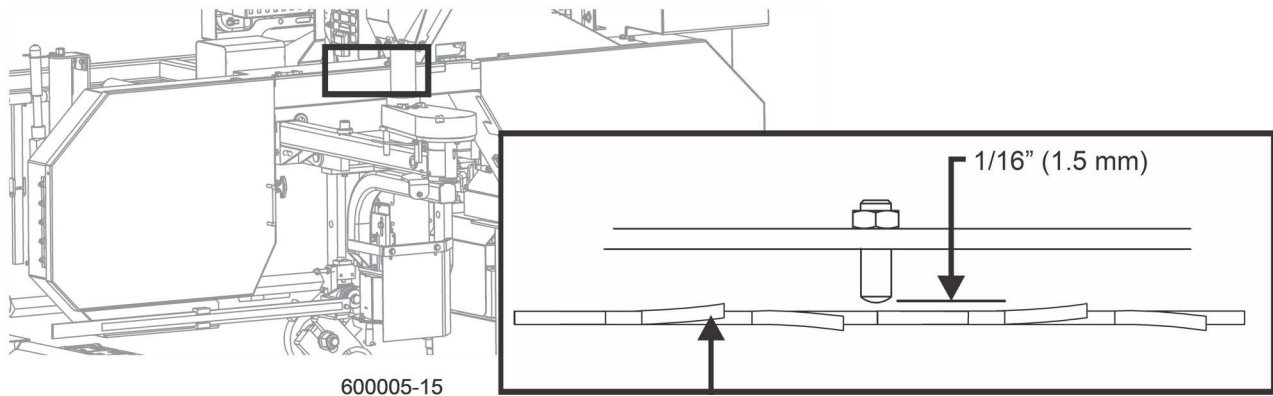

FIG. 5-2

5.3 Sawdust Removal

WARNING! Before performing service near moving parts such as blades, pulleys, motors, belts and chains, first turn the key switch to the OFF (#0) position and remove the key. If the key is turned on and moving parts activated, serious injury may result.

Remove the excess sawdust from the blade wheel housings and sawdust chute every blade change.

WARNING! Always keep clear of exiting sawdust. Keep hands, feet and any other objects away from the sawdust chute when operating sawmill.

WARNING! Always check to ensure the steel fingers inside the sawdust chute are in place before operating the sawmill. The steel fingers have been designed to help prevent a broken blade or some other object from becoming a projectile and exiting the sawdust chute. Failure to have these fingers in place may result in serious injury.

Remove all sawdust and debris from around the velocity fuse valves **every 8 hours** of operation. The valves are located at the bottom of the log loader cylinders.

Remove sawdust buildup as necessary from the battery box lid and top rail cover.

CAUTION! Failure to remove sawdust buildup from the battery box lid and/or track rail cover could result in damage to these parts when the saw head is lowered to its lowest position.

Remove sawdust and debris from grounding block along the bed rail and mast.

5.4 Carriage Track, Wiper & Scraper

WARNING! Before performing service near moving parts such as blades, pulleys, motors, belts and chains, first turn the key switch to the OFF (#0) position and remove the key. If the key is turned on and moving parts activated, serious injury may result.

Properly maintaining the sawmill carriage track is critical in preventing corrosion that can cause pitting and scaling on the rail surfaces. Pitted and scaled surfaces can, in turn, cause rough cuts or jerky power feed movement.

1. Clean track rails to remove any sawdust and sap buildup **every 8 hours** of operation.
2. Use a light-grade sandpaper or emery cloth to sand off any rust or other adhering particles from the rails.

CAUTION! Keep track rails free of rust. Formation of rust on the track rail in the areas where the cam bearings roll can cause rapid deterioration of the track rail's surface.

- Lubricate the rails by wiping them with Dexron III ATF transmission fluid.

Lubrication will help protect the rails from corrosive elements such as acid rain and/or moisture from nearby bodies of salt-water (if applicable). This lubrication is essential to maintain the integrity of the track rails and track rollers and to achieve long service life.

- Remove sawdust from the track roller housings and lubricate the felt track wiper every twenty-five hours of operation.
- Remove the track roller housing covers and brush any sawdust buildup from the housings.
- Clean and lubricate the felt track wipers.
- Unbolt the middle track cover, remove from the sawmill and remove any sawdust buildup.
- Soak the felt wiper with Dexron III transmission fluid.



CAUTION! Reinstall the track wiper so that it lightly touches the track rail. If the wiper presses too firmly against the rail, it can cause the power feed to bind.

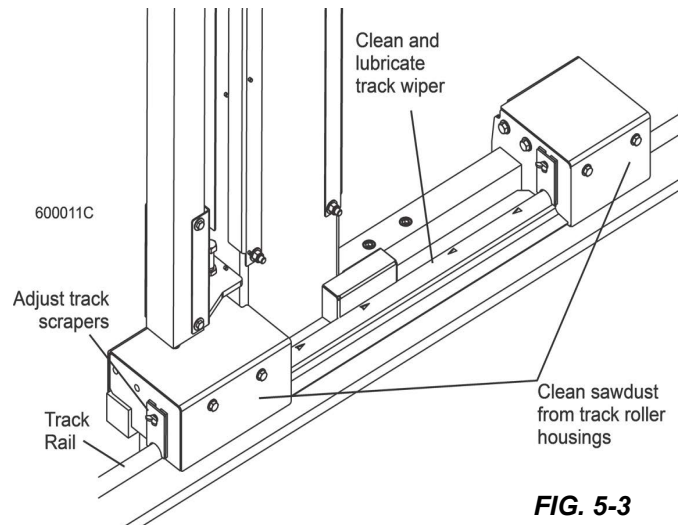

FIG. 5-3

- Check the track scrapers as needed.
- Make sure the scrapers fit firmly against the rail.
- If a track scraper needs to be adjusted, loosen the screw, push the scraper downward until it fits firmly against the rail, and retighten the screw.

5.5 Vertical Mast Rails



WARNING! Before performing service near moving parts such as blades, pulleys, motors, belts and chains, first turn the key switch to the OFF (#0) position and remove the key. If the key is turned on and moving parts activated, serious injury may result.

Clean the vertical mast rails **every 50 hours** of operation.



CAUTION! Never use grease on the mast rails as it will collect sawdust.

5.6 Miscellaneous



WARNING! Before performing service near moving parts such as blades, pulleys, motors, belts and chains, first turn the key switch to the OFF (#0) position and remove the key. If the key is turned on and moving parts activated, serious injury may result.

- Oil all chains with Dexron III ATF **every 50 hours** of operation.



CAUTION! Do not use chain lube. It causes sawdust buildup in chain links.

- Apply a thin film of a NLGI No. 2 grade lithium grease to the blade guide arm **every 50 hours** of operation to help prevent it from rusting.

3. Adjust the blade guide arm drive chain as necessary to prevent the arm from slipping by loosening the blade guide arm motor mounting plate bolts and sliding the motor to take slack out of the chain.
4. Apply NLGI No. 2 grade lithium grease to the drive belt tensioner pivot **every 50 hours** of operation.
5. Grease the clamp mechanism, loading arm and side support pivots with a NLGI No. 2 grade lithium grease **every 50 hours** of operation.
6. Check the mill alignment every setup ([See Section SECTION 7](#)).
7. Make sure all safety warning decals are readable.
 - Remove sawdust and dirt.
 - Replace any damaged or unreadable decals immediately.
 - Order new decals.

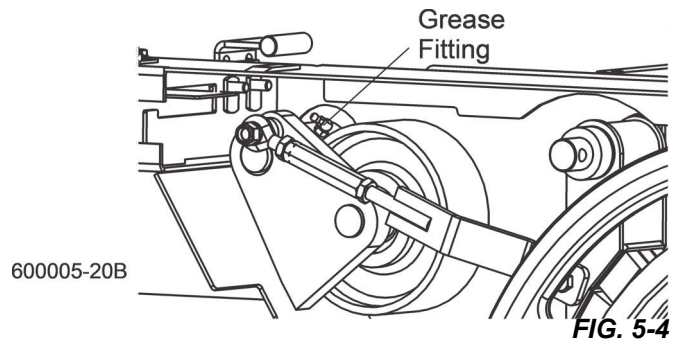

5.7 Blade Tensioner

WARNING! Before performing service near moving parts such as blades, pulleys, motors, belts and chains, first turn the key switch to the OFF (#0) position and remove the key. If the key is turned on and moving parts activated, serious injury may result.

1. Add fluid such as Dexron III or Conoco MV32 to the tensioner assembly as needed.
2. To add fluid, remove the plug from the pump reservoir and turn the release valve counter-clockwise to open.
3. Pry the assembly forward until the tensioner piston is completely collapsed inside the housing.
4. Fill the reservoir to 1/2" (12mm) from the top.
5. Replace the plug to the pump reservoir.

5.8 Blade Wheel Belts

WARNING! Before performing the key switch to the OFF (#0) position and remove the key. If the key is turned on and moving parts activated, serious injury may result.

1. Rotate the blade wheel belts **every 50 hours** and check them for wear.

NOTE: Rotating the belts will provide longer belt life.

2. Replace belts as necessary.
3. Use only belts supplied by Wood-Mizer.

5.9 Drive Belt Adjustment

WARNING! Disconnect and lockout power before performing any service to the electrical system. For battery-powered equipment, disconnect the negative battery terminal cable. For AC-powered equipment, follow the lockout procedure provided in the safety section ([See Section 2.2](#)). Failure to do so may result in injury and/or electrical system damage.

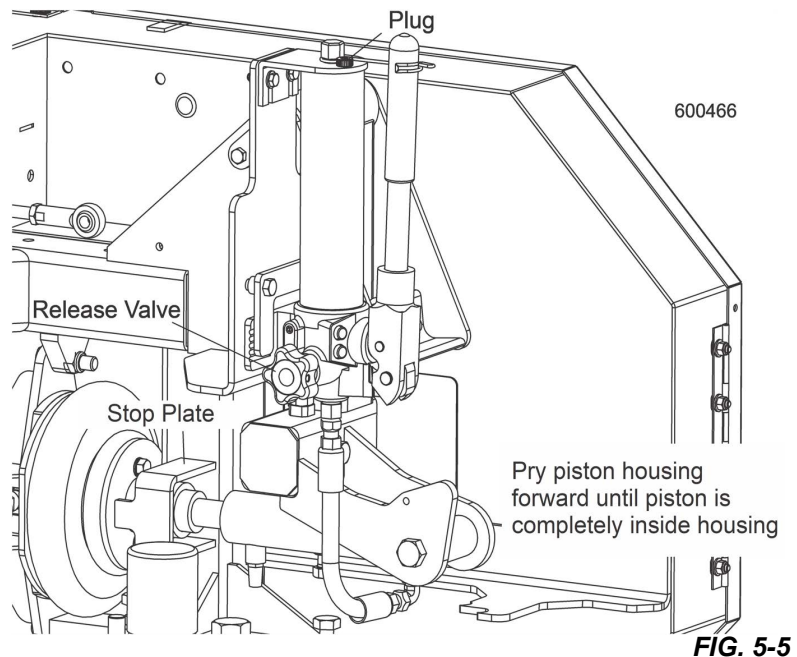

WARNING! Before performing service near moving parts such as blades, pulleys, motors, belts and chains, first turn the key switch to the OFF (#0) position and remove the key.

WARNING! Do not adjust the engine drive belts or belt support bracket with the engine running.

CAUTION! Do not over-tighten the drive belt. Damage to the engine may result

See the table below for drive belt tension specifications for your model sawmill. Measure the belt tension with a gauge.

NOTE: Wood-Mizer offers a belt tension gauge (Part No. 016309) that will let you accurately measure the belt tension.

Engine/ Motor	New Belt Installation/New Sawmill Operation				Subsequent Adjustment		
	Deflection Inches (mm)	Installation Force lbs. (kg)	Check After First	Acceptable Force lbs. (kg)	Then Check Every	Deflection Inches (mm)	Force lbs. (kg)
ALL	3/8" (9.5mm)	14 lbs. (6.35kg)	20 hrs	14 lbs. (6.35kg)	50 hrs	3/8" (9.5mm)	14 lbs. (6.35kg)

TABLE 5-2

Adjust belt tension

1. Turn the key switch to the accessory (#3) position.
2. Engage the drive belt with the blade switch on the control panel.
3. Turn the key switch to the off (#0) position and remove the key.
4. Check the belt tension as described above.
5. Loosen the jam nut and turn the adjustment tube until the belt is properly tensioned.
6. Tighten the jam nut.
7. Adjust the enhancement rods approx. 1/4" away from the belt.
8. Replace the key and turn the key switch to the accessory (#3) position.
9. Turn the blade switch off and back on and recheck the belt tension.
10. Repeat adjustments as necessary until proper belt tension is achieved when the belt is engaged.
11. After making adjustments to the drive belt, always check the brake adjustment ([See Section 5.11](#)).
12. Periodically check the drive belt for wear.
13. Replace any damaged or worn belts as needed.

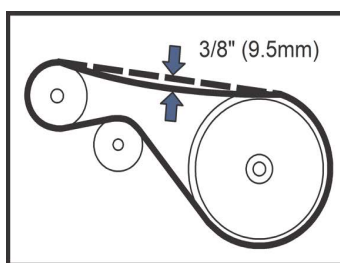

600224

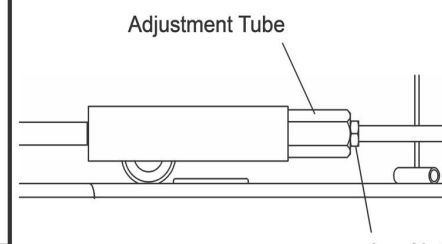

Jam Nut
FIG. 5-6

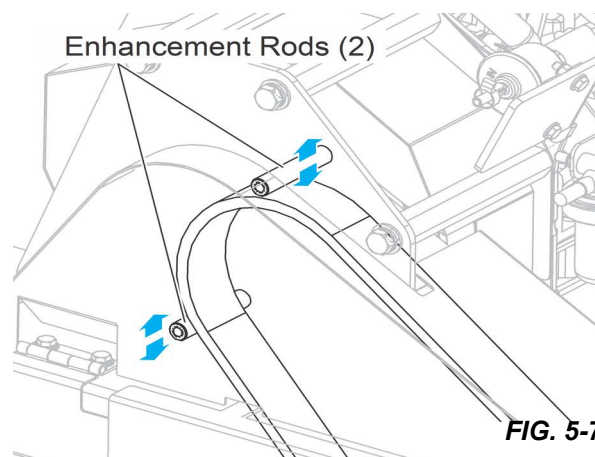

FIG. 5-7

5.10 Brake Adjustment

WARNING! Before performing service near moving parts such as blades, pulleys, motors, belts and chains, first turn the key switch to the OFF (#0) position and remove the key. If the key is turned on and moving parts activated, serious injury may result.

1. Check the brake pads for wear **every 200 hours** of operation, after each drive belt adjustment, or if the blade does not stop quickly.
2. Replace brake pads if damaged or worn.
3. Adjust the brake pads if the drive belt jumps from the drive pulley when the autoclutch is disengaged.
 - a. Adjust the brake so the blade stops no more than 7 seconds after turning the blade switch off.
 - b. Loosen the jam nuts around the adjustment turnbuckle and turn the turnbuckle to adjust the brake.
 - c. Retighten the jam nuts.
4. Multiple adjustments of the brake will affect engine RPM at idle.

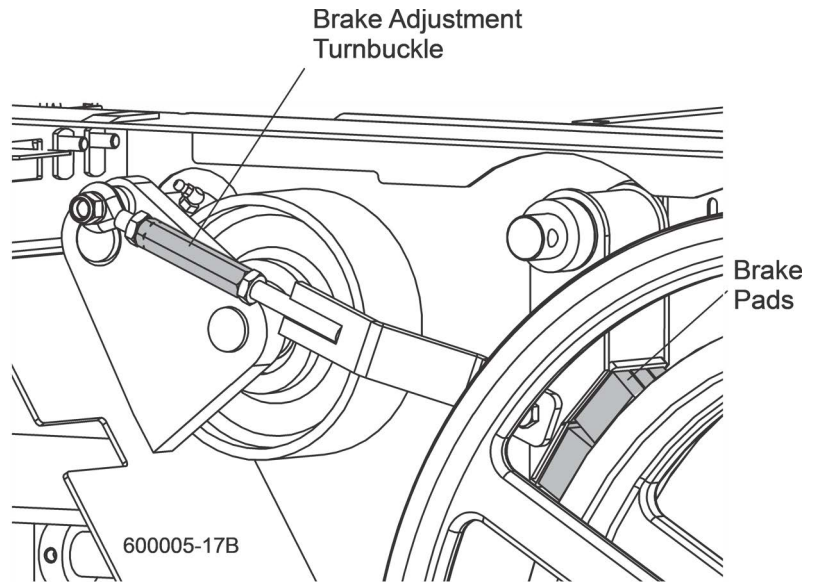

FIG. 5-8

If you notice any change in the idle of the engine after adjusting the brake, check the RPM and adjust the throttle cable if necessary to allow the throttle plate to rest on the idle stop screw (See Engine manual).

5.11 Autoclutch Belt

Tighten the clutch belt as necessary to prevent slippage.

1. Remove the two cover bolts and washers and remove the cover.
2. Loosen the clutch motor mounting bolts and slide the motor up to tighten the belt.
3. Tighten the belt to 1/16" deflection with 1/4 lb. deflection force.

Wood-Mizer offers a belt tension gauge (Part No. 016309) that will let you accurately measure the belt tension.

4. Inspect the belt for wear or cracks and replace as necessary.

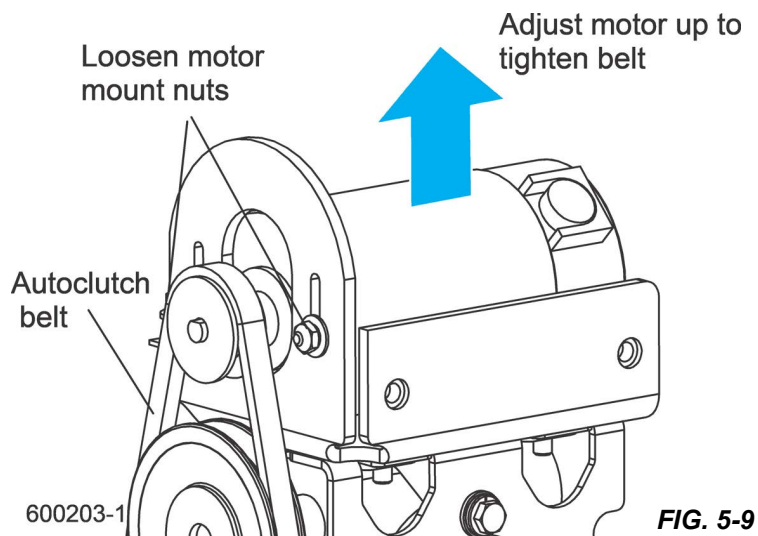

FIG. 5-9

5.12 Hydraulic System



WARNING! Disconnect and lockout power before performing any service to the electrical system. For battery-powered equipment, disconnect the negative battery terminal cable. Failure to do so may result in injury and/or electrical system damage.

1. Check the hydraulic fluid level **every 8 hours** of operation.
2. Add fluid as necessary.
3. Use only Wood-Mizer approved hydraulic fluid such as Mobil Unavis HVI 26.

If humidity is a problem or the mill is used outside in humid weather, drain and replace two quarts (.95 liters) of fluid every six months. This will drain any accumulated water and help prevent pump failure due to water ingestion. It also will prevent excessive fluid wear and allow the fluid to maintain its hot end performance. If humidity is not a problem, drain and replace one gallon (3.8 liters) of fluid every year to prevent fluid wear.

4. Replace the hydraulic system cartridge filter **after 50 hours** of operation, then **every 500 hours** of operation.
5. Periodically check all hydraulic lines and fitting as needed.

6. Replace as necessary.

5.13 Power Feed

WARNING! Before performing service near moving parts such as blades, pulleys, motors, belts and chains, first turn the key switch to the OFF (#0) position and remove the key. If the key is turned on and moving parts activated, serious injury may result.

1. Adjust the power feed chain as needed.
2. Measure the power feed chain tension with the saw head all the way toward the rear of the mill.
3. Use the adjustment nut on the feed tensioner at the front of the mill to tighten or loosen the power feed chain.

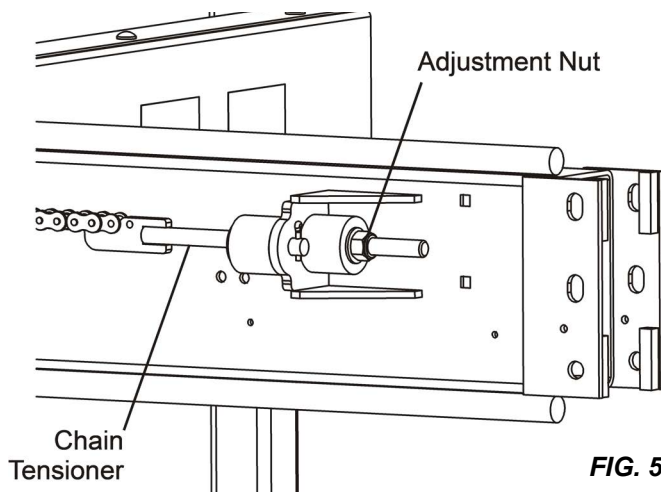

FIG. 5-10

4. Adjust the chain until it measures 7 to 8 inches (17.8 to 20.3 cm) from the top of the top rail at its lowest point.

CAUTION! Do not overtighten the feed chain. Damage to the power feed motor may result.

Refer to the diagram for power feed chain routing instructions.

5.14 Charging the Battery

DANGER! Batteries expel explosive gases. Keep sparks, flames, burning cigarettes, or other ignition sources away at all times. Always wear safety goggles and a face shield when working near batteries. Failure to do so will cause serious injury.

WARNING! Battery posts, terminals and related accessories contain lead and lead compounds, chemicals known to the State of California to cause cancer and reproductive harm. Wash hands after handling.

Charge the battery in a well ventilated area. Do not attempt to charge a frozen battery.

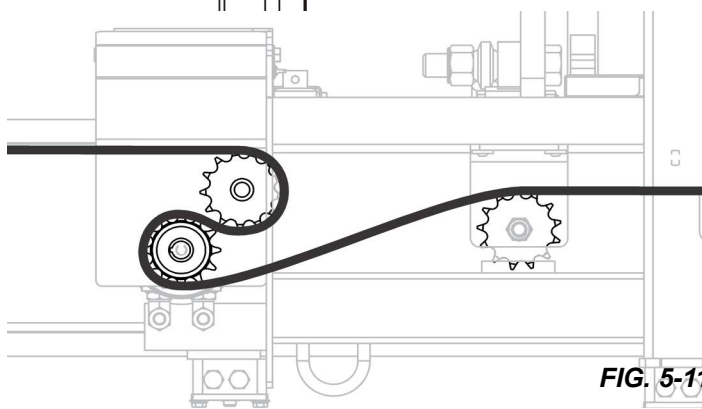

FIG. 5-11

Use extreme care to avoid spilling or splashing electrolyte (which is dilute sulfuric acid) as it can destroy clothing and burn the skin.

EMERGENCY TREATMENT FOR CONTACT WITH BATTERY COMPONENTS (LEAD/SULFURIC ACID) per SDS (Safety Data Sheet):

EYE CONTACT	Sulfuric Acid and Lead: Flush eyes immediately with large amounts of water for at least 15 minutes while lifting lids. Seek immediate medical attention if eyes have been exposed directly to acid.
SKIN CONTACT	Sulfuric Acid: Flush affected area(s) with large amounts of water using deluge emergency shower, if available, shower for at least 15 minutes. Remove contaminated clothing, including shoes. If symptoms persist, seek medical attention. Wash contaminated clothing before reuse. Discard contaminated shoes. Lead: Wash immediately with soap and water.
INGESTION	Sulfuric Acid: Administer large amounts of water. Do NOT induce vomiting or aspiration into the lungs may occur and can cause permanent injury or death; consult physician.
INHALATION	Sulfuric Acid: Remove to fresh air immediately. If not breathing, give artificial respiration. If breathing is difficult, give oxygen. Consult a physician. Lead: Remove from exposure, gargle, wash nose and lips; consult physician.

If electrolyte is spilled or splashed on any surface of the machine, it should be neutralized and rinsed with clean water.



CAUTION! Do not overcharge the battery. Overcharging may reduce the overall service life of the battery.

Be sure the battery is fully charged before transporting the sawmill. If the battery is not fully charged, excessive vibration could reduce the overall service life of the battery.

1. Raise the saw head to access the battery box.
2. Turn the key to the OFF (#0) position and remove the key.
3. Remove the battery box lid.
4. Clean the battery terminals if necessary.
5. Connect the positive charger/jumper cable directly to the positive battery terminal.
6. Connect the negative charger/jumper cable to a grounded metal surface.
7. Follow the instructions supplied with your specific battery charger.

NOTICE Do not overcharge the battery, especially when using a high-rate or “boost” charger (40 amps or higher). These are intended to quickly charge a good battery that is discharged. They are not intended for unattended or long-term charging.

8. After the battery is completely recharged, remove the negative charger/jumper cable from ground.
9. Remove the positive charger/jumper cable from the battery.
10. Replace the battery box lid.

5.15

5.16 Maintenance Chart

MAINTENANCE LOG (Check <i>Engine And Option Manuals</i> for additional maintenance procedures)	MANUAL REFERENCE	MAINTENANCE INTERVAL
Clean sawdust from hydraulic loader fuses, battery box lid & track cover	See Section 5.3	8 hours
Clean and lubricate track	See Section 5.4	8 hours
Check blade guide Block/roller wear	See Section 5.2	8 hours Every blade change
Remove excess sawdust from blade wheel housings and sawdust chute	See Section 5.3	8 hours Every blade change
Inspect fingers inside sawdust chute	See Section 5.3	8 hours Every blade change
Remove sawdust from upper track roller housings	See Section 5.4	25 hours
Check Blade Guide Block Spacing	See Section 5.2	25 Hours
Clean and lubricate upper track wiper	See Section 5.4	25 hours
Clean & lube mast rails	See Section 5.5	50 hours
Grease pivot points and bearings/oil chains	See Section 5.7	50 hours
Rotate drive/idle blade wheel belts/check for wear	See Section 5.9	50 hours
Inspect hydraulic lines & fittings	See Section 5.12	50 hours
Check belt tensions	See Section 5.10 See Section 5.14 See Section 5.15	50 hours
Check feed chain tensions	See Section 5.14 See Section 5.15	50 hours
Check brake pads	See Section 5.11	200 hours
Check blade throat screw	See Section 5.2	500 hours
Replace hydraulic system filter	See Section 5.12	After first 50 hours, then every 500 hours

SECTION 6 TROUBLESHOOTING GUIDE

6.1 Sawing Problems



WARNING! Before performing service near moving parts such as blades, pulleys, motors, belts and chains, first turn the key switch to the OFF (#0) position and remove the key. If the key is turned on and moving parts activated, serious injury may result.

PROBLEM	CAUSE	SOLUTION
Blades Dull Quickly	Dirty logs	Clean or debark logs, especially on entry side of the cut
	When grinding teeth, heating too much and causing teeth to soften	Grind just enough metal to restore sharpness to the teeth. Use water/coolant while sharpening blade
	Poor sharpening techniques	Make sure the tip is being sharpened completely (See Sharpener Manual)
Blades Break Prematurely	Poor sharpening techniques	See Sharpener Manual
	Tension too tight	Tension blade to recommended specifications
Blade Does Not Track Right on Drive Wheel	Cant adjustment is incorrect	Readjust
Drive Belts Wear Prematurely or Jump	Engine/motor and drive pulleys out of alignment	Align pulleys See Section 6.9.
Boards Thick Or Thin On Ends Or Middle Of Board.	Stress in log which causes log to not lay flat on the bed.	After log has been squared, take equal cuts off opposing sides. Take a board off the top. Turn the log 180 degrees. Take a board off. Repeat, keeping the heart in the middle of the cant, and making it your last cut.
	Set in teeth.	Resharpen and reset blade.
	Bed rails misaligned.	Realign sawmill.
Height Adjustment Jumps or Stutters When Moving Up or Down.	Up/down chain improperly adjusted.	Adjust up/down chain.
	Up/down belt loose.	Replace belt.
Lumber Is Not Square	Vertical side supports not square to bed	Adjust side supports.
	Blade not parallel to bed rails	Adjust bed rails parallel to blade.
	Sawdust or bark between cant and bed rails	Remove particles
Sawdust Builds Up On Track	Tooth set problems	Resharpen and reset blade
	Excessive oiling	Do not oil track
	Track wipers worn	Adjust wipers to firmly contact track
Wavy Cuts	Track is sticky	Clean track with solvent and apply silicone spray
	Excessive feed	Slow feed rate
	Improperly sharpened blade (This will be the problem 99% of the time!)	Resharpen blade (See Sharpener Manual - read entire manual!)
	Blade guides improperly adjusted	Adjust blade guides.
	Sap buildup on blade	Use Water Lube.
	Tooth set problem	Resharpen and reset blade

6.2 Engine/Motor and Drive Pulleys Alignment

 **WARNING!** Before performing service near moving parts such as blades, pulleys, motors, belts and chains, first turn the key switch to the OFF (#0) position and remove the key. If the key is turned on and moving parts activated, serious injury may result.

 **WARNING!** Do not for any reason adjust the engine drive belts or belt support bracket with the engine running. Doing so may result in serious injury.

1. Install and properly tension the drive belt ([See Section 5.10](#)).
2. With the autoclutch disengaged, use a straight edge to check the alignment of the pulley on the engine/motor to the alternator pulley.
3. Loosen the bushing on the engine/motor pulley and adjust if necessary until it is aligned with the alternator pulley.
4. With the autoclutch disengaged, use a straight edge to check the alignment of the engine/motor pulley to the main drive pulley.
5. Loosen the bushing on the drive pulley and adjust if necessary until it is aligned with the engine/motor pulley.
6. Check that all engine mounting bolts and pivot bushing clamps are tight.
7. Engage the autoclutch and recheck the pulley alignment; adjust if necessary.
8. If any pulleys were adjusted, recheck the drive belt support(s) and adjust if necessary ([See Section 5.10](#)).

6.3 System Diagnosis

 **WARNING!** Before performing service near moving parts such as blades, pulleys, motors, belts and chains, first turn the key switch to the OFF (#0) position and remove the key. If the key is turned on and moving parts activated, serious injury may result.

NOTICE 12VDC is an approximate reading. If the engine is not running and the battery is somewhat low, it could be lower than 12VDC. If the engine is running it could be as high as 14.3VDC.

PROBLEM	CAUSE	SOLUTION
Front screen(HMI) black	E-stop depressed	Release E-stop button
	Blown fuse	Check main fuse(F1) Check battery fuse(F8) Check main ignition fuse(F17) Check bed(Bed Hydraulic Box) ignition fuse(F3) Replace fuses if necessary
	Accessory(Ignition) Solenoid(K1) failure	See Accessory(Ignition) Solenoid(K1) failure
	Problem with cable (W1) that plugs into Console(Operator) and Frame of mill	Inspect for visible damage Check the pins in the connectors on each end for visible damage or pushed in Replace damaged cable
	Damaged key switch(S1)	Check for 12VDC on terminals 1 and 3 of the key switch If there is not 12VDC start with the first cause in the list Check for 12VDC on terminal 2 when the key is on(1) Inspect for debris in contact Replace damaged contacts

PROBLEM	CAUSE	SOLUTION
Lube pump not working		Make sure the Lube Pump is active on the Front screen(HMI) Auto-Clutch(Blade on) must be engaged and the head must be feeding forward
	Blown lube pump fuse(F10)	Check lube pump fuse(F10) Replace if necessary
	Faulty lube pump relay(1M3)	While attempting to run the lube pump: Check the status of the LED on the relay: Solid on for constant flow, blinking for pulse flow. Check for 12VDC on the coil Check for 12VDC on the output Replace if necessary
	Faulty lube pump(M3)	While attempting to run the lube pump: Check for 12VDC at the motor connector Replace if necessary
Auto-clutch not working	Tripped auto-clutch breaker(CB4)	Reset the breaker
	Faulty auto-clutch relay(1M4)	While attempting to cycle the Auto-clutch: Check to see if the LED on the relay is on Check for 12VDC on the coil Check for 12VDC on the output Replace if necessary
	Faulty auto-clutch motor(M4)	While attempting to cycle the Auto-clutch: Check for 12VDC at the motor connector Replace if necessary
Auto-clutch not stopping	Faulty sensor(B1 or B2)	Check the status of the sensors while the auto-clutch is running on the Head ECU I/O diagnostic screen Replace if necessary
	Faulty auto-clutch relay(1M4), contact welded	If the LED of the relay is off, the contacts have welded Replace if necessary
Blade Guide not working	Tripped blade-guide breaker(CB5)	Reset the breaker
	Faulty blade-guide relay(1M5 or 2M5)	While attempting to run the blade guide in: Check to see if the LED on the relay(1M5) is on Check for 12VDC on the coil Check for 12VDC on the output While attempting to run the blade guide out: Check to see if the LED on the relay(2M5) is on Check for 12VDC on the coil Check for 12VDC on the output Replace if necessary
	Faulty blade-guide motor(M5)	While attempting to run the blade guide in or out: Check for 12VDC at the motor connector Replace if necessary
Debarker In/Out not working	Tripped debarker in/out breaker(CB6)	Reset the breaker

PROBLEM	CAUSE	SOLUTION
	Faulty debarker in/out relay(1M6 or 2M6)	<p>While attempting to run the debarker in: Check to see if the LED on the relay(1M6) is on Check for 12VDC on the coil Check for 12VDC on the output</p> <p>While attempting to run the debarker out: Check to see if the LED on the relay(2M6) is on Check for 12VDC on the coil Check for 12VDC on the output</p> <p>Replace if necessary</p>
	Faulty debarker in/out motor(M6)	<p>While attempting to run the debarker in or out: Check for 12VDC at the motor connector</p> <p>Replace if necessary</p>
Debarker Blade not working		<p>Make sure the Debarker is active on the Front screen(HMI) Auto-Clutch(Blade on) must be engaged and the head must be feeding forward</p>
	Tripped debarker breaker(CB2)	Reset the breaker
	Faulty debarker solenoid(1M2)	<p>While attempting to run the debarker: Check for 12VDC on the coil Check for 12VDC on the right post of the solenoid</p> <p>Replace if necessary</p>
	Faulty debarker blade motor(M2)	<p>While attempting to run the debarker: Check for 12VDC at the motor terminals Check for worn motor brushes</p> <p>Replace if necessary</p>
Head ECU Communication Loss	Loss of power	<p>Check Head ECU fuses(F14 and F15)</p> <p>Replace fuses if necessary</p>
	Low Battery	<p>See Low Battery The ECU records a DTC for Low Voltage at 10 volts. If the voltage drops much lower than 10 volts the ECU will shut down but the HMI could still be on</p>
	Faulty CANbus connection	<p>Check connection of termination resistor in the Operator control Check continuity of the CAN Hi and CAN Lo wires from the Operator Control all the way to the Head Control. Determine where the connection is poor Check CAN Hi and CAN Lo wires through Engine Harness, make sure there are not any damaged wires</p>
Bed ECU Communication Loss	Loss of power	<p>Check Bed ECU fuse(F4)</p> <p>Replace fuse if necessary</p>
	Faulty CANbus connection	<p>Check connection of termination resistor in the Operator control Check continuity of the CAN Hi and CAN Lo wires from the Bed Control all the way to the Head Control. Determine where the connection is poor</p>
Operator ECU Communication Loss	Loss of power	<p>Check Operator ECU fuse(F5)</p> <p>Replace fuse if necessary</p>

PROBLEM	CAUSE	SOLUTION
	Faulty CANbus connection	Check connection of termination resistor in the Operator control Check continuity of the CAN Hi and CAN Lo wires from the Operator Control all the way to the Head Control. Determine where the connection is poor
Engine ECU Communication Loss	Loss of power	Check head control fuse(F12), check engine harness fuse(F1) Replace fuse if necessary
	Faulty CANbus connection	Check connection of termination resistor in the Operator control Check continuity of the CAN Hi and CAN Lo wires from the Engine ECU all the way to the Head Control. Determine where the connection is poor
Throttle ECU Communication Loss	Loss of power	Check Throttle ECU fuse(F16) Replace fuse if necessary
	Faulty CANbus connection	Check connection of termination resistor in the Operator control Check continuity of the CAN Hi and CAN Lo wires from the Throttle ECU all the way to the Head ECU. Determine where the connection is poor
Failed to Reach Target	Transducer Magnet Position	Check the gap on the magnet, should not be larger than 1/8"
	Debris on mast	Inspect for debris. Inspect proper operation of rollers.
	Check up/down hydraulic pressures	The system should have a minimum 1400 psi when moving up/down only.
	Faulty up/down Cylinder	Un-mount the top of the cylinder: While attempting a down move, does the cylinder move up? Replace if necessary
	Setworks Tuning	Refer to your Wood-Mizer technician for assistance with tuning.
Engine Won't Crank	E-stop depressed	Release E-stop button
	Blown fuse	Check main fuse(F1) Check battery fuse(F8) Check starter solenoid fuse(F13) Replace fuses if necessary
	Problem with cable (W1) that plugs into Console(Operator) and Frame of mill	Inspect for visible damage Check the pins in the connectors on each end for visible damage or pushed in Replace damaged cable

PROBLEM	CAUSE	SOLUTION
	Damaged key switch(S1)	<p>Check for 12VDC on terminals 1 and 3 of the key switch If there is not 12VDC start with the first cause in the list Check for 12VDC on terminal 3 when the key is on the start position(2)</p> <p>Inspect for debris in contact Replace damaged contacts</p>
	Faulty starter solenoid relay(1M1)	<p>While attempting to crank the engine: Check for 12VDC on the coil Check for 12VDC on the output</p> <p>Replace if necessary</p>
	Problem with harness (Z1) from the Head control to the Engine	<p>Inspect for visible damage Check wire 105 for damage</p> <p>Replace damaged harness</p>
	Faulty Starter(M1)	<p>While attempting to crank the engine: Check for 12VDC on the output of the starter solenoid.</p>
Engine Won't Start	Is the engine cranking?	See Engine Won't Crank
	Check DTC Code history for Engine ECU fault codes	<p>If there are any Main Relay or Actuator Relay errors inspect the relays</p> <p>Replace as necessary.</p> <p>Contact Crosspoint(Yanmar)</p>
	Blown fuse	<p>Check Engine Harness Power fuse(F7) Check Engine Harness Ignition fuse(F12)</p> <p>Engine Harness fuses: Main Relay fuse(F1)</p> <p>Replace fuses if necessary</p>
	Faulty Main Relay	<p>Inspect for debris, relay connectors should have dielectric grease in them to prevent debris from entering and corrosion. Clean out debris if necessary, grease if necessary.</p> <p>Replace if necessary</p>
	Faulty Actuator Relay	<p>Inspect for debris, relay connectors should have dielectric grease in them to prevent debris from entering and corrosion. Clean out debris if necessary, grease if necessary.</p> <p>Replace if necessary</p>
	Engine Harness J5 Connector(Large Round 21-pin Connector)	Inspect for proper connection and debris.
Low Battery	Bad connection on oil pressure switch	<p>This can cause the EGR valve to run after the engine has been turned off Key switch was left on for an extended period with the engine not running Defective battery, replace</p>
Accelerator Pedal Position Sensor "A" errors	Throttle ECU Issue	See Throttle ECU Communication Loss

PROBLEM	CAUSE	SOLUTION
	Blade Speed setting	Blade speed can be set between 2840-5800 ft/min. If the setting gets below 2840 it can cause the Engine ECU to display this fault
	Low Battery	Low voltage could cause the Throttle ECU to shut down See Low Battery Cranking in cold weather could cause the battery voltage to temporarily drop causing this issue
Accessory(Ignition) Solenoid(K1) failure	No coil voltage	Check for 12VDC on top and bottom posts when the key switch is on(1)
	No output voltage	Listen for a distinct click from the solenoid when the key switch is turned on(1) Check for 12VDC on right post of solenoid when the key switch is on(1) Condensation can build on contacts in cold temperatures, then freeze when not in use. Cycling the key switch from off(0) to on(1) several times can break the ice Replace faulty solenoid
Hydraulic Oil Temperature High		Verify oil temperature on sight gauge on the hydraulic oil reservoir
	Dirty Oil Cooler or Engine Radiator	If the temperature raises slowly over several hours it is most likely reduced air flow through the cooler from saw dust build up Clean saw dust build up out of oil cooler Remove oil cooler from engine radiator and clean saw dust build up out of the engine radiator
	Faulty temperature switch(S2)	If the oil temperature on the sight gauge is well below 170°F either the switch could be faulty or there is a bad connection. Check to make sure all connectors are securely fastened. Replace if necessary
	Contaminated Pressure Relief Valve(V1.TS1, V1.RV1, V5.RV1), Reference Hydraulic Schematic for valve locations	Remove and clean if you have the ability to do so properly. Oil filter dirty and in bypass Replace if necessary, filter change every 500 hours per manual
Improper Hydraulic Pressure Reading	Faulty pressure transducer(U2)	Engine Idle and no active hydraulic functions pressure should be around 300psi Replace if necessary
	Faulty connections	Check to make sure all connectors are securely fastened
Head will not raise	Low hydraulic pressure	See Faulty pressure relief valve(V1.TS1)
	Faulty cylinder	Shaft seal may be damaged Replace if necessary

PROBLEM	CAUSE	SOLUTION
Faulty pressure relief valve(V1.TS1) Reference Hydraulic Schematic for valve location	Contamination in cartridge	Head Up/Down functions should be 1400psi or a little higher Feed Forward/Reverse functions at slow speeds should be around 1100psi Bed functions when dead headed should be around 2200psi Replace if necessary

SECTION 7 SAWMILL ALIGNMENT

The Wood-Mizer sawmill is factory aligned. Two alignment procedures are available to realign the sawmill if necessary. The Routine Alignment instructions should be performed as necessary to solve sawing problems not related to blade performance. The Complete Alignment procedure should be performed approximately every 1500 hours of operation (sooner if you regularly transport the sawmill over rough terrain).

7.1 Routine Alignment Procedure

Blade Installation

1. Remove the blade and check the blade wheel belts.
2. Remove any sawdust buildup from the surface of the belts.
3. Replace worn belts if they do not keep the blade from contacting the blade wheel.
4. Install a clean blade and apply the appropriate tension ([See Section 3.4](#)).
5. Inspect the blade guide blocks for damage or wear and replace as necessary.
6. Check the blade guide blocks and drive side deflector plate are properly adjusted ([See Section 5.2](#)).
7. Adjust the idle-side cant control to track the blade ([See Section 3.5](#)).
8. Close the blade housing covers and make sure all persons are clear of the saw head.
9. Start the engine (or motor).
10. Engage the blade, rotating the blade until the blade positions itself on the wheels.



WARNING! Do not spin the blade wheels by hand. Spinning the blade wheels by hand may result in serious injury.

11. Disengage the blade.
12. Turn the engine off and remove the key.

Saw Head Tilt

As the blade enters a wide log or cant, the outside of the saw head will drop down slightly. To compensate for the drop, the saw head is adjusted 1/16" (1.5 mm) higher at the outside.

1. Move the saw carriage so the blade is positioned over a bed rail.
2. Adjust the blade guide arm to 1/2" (15 mm) from full open.
3. Raise the saw head so the bottom of the blade measures 14 3/4" (375 mm) from the top surface of the bed rail near the inner blade guide assembly.
4. Measure from the blade to the bed rail near the outer blade guide assembly.

This measurement should be 1/16" (1.5 mm) higher than the inner measurement or 14 13/16" (376.5 mm).

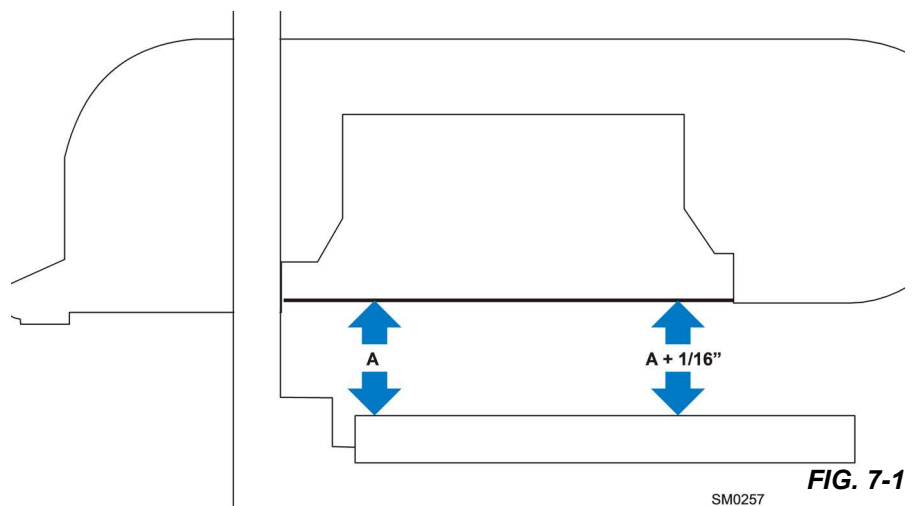

SM0257

FIG. 7-1

5. To adjust the saw head tilt, use the bolts located at the bottom of the saw head mast.
6. Loosen the three sets of four retaining plate bolts.
7. To raise the outside of the saw head, back the stop bolts out, then tighten the adjustment bolts.
8. To lower the outside of the saw head, loosen the adjustment bolts and tighten the stop bolts.
9. Recheck the measurement from the blade to the bed rails and adjust the stop bolts and adjustment bolts until the outside of the saw head is 1/16" (1.5mm) higher than the inside.
10. Retighten the retaining plate bolts.

Blade Guide Arm Alignment

The blade guide arm moves the outer blade guide in and out. If the arm becomes loose, the blade guide will not deflect the blade properly, causing inaccurate cuts. A loose blade guide arm can also cause blade vibration.

1. Adjust the blade guide arm in to 1/2" (13 mm) from fully closed.
2. Manually try to move the arm up and down.

If you can move the arm by hand, you will need to tighten the arm rollers.

3. Loosen the jam nuts and turn the adjustment bolts in to tighten the blade guide arm rollers.
4. Retighten the jam nuts.
5. After tightening the blade guide arm rollers, check that the arm is aligned properly.

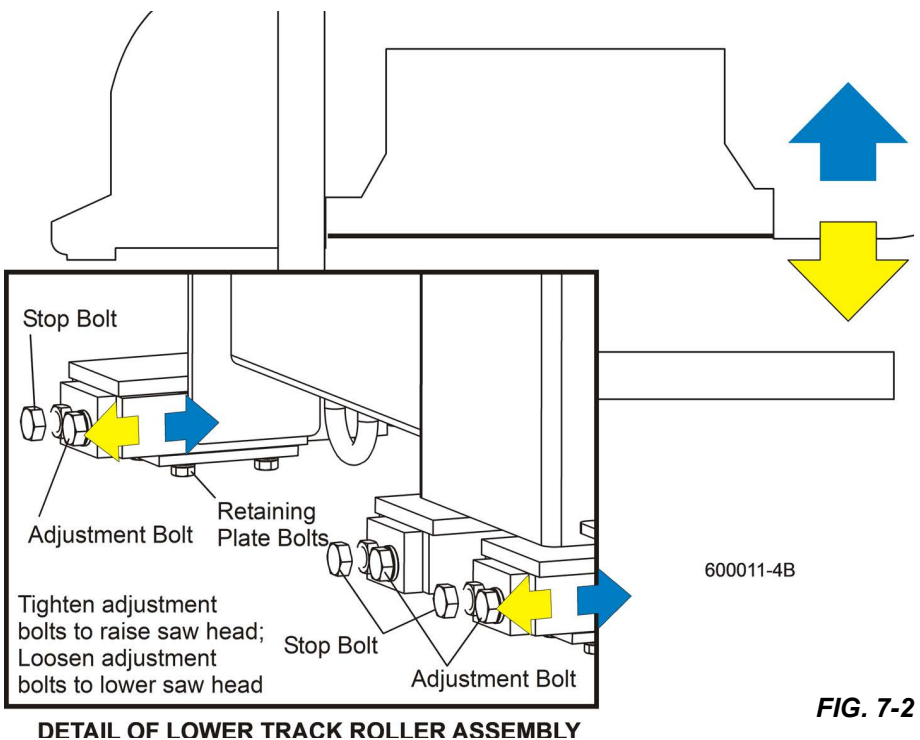

FIG. 7-2

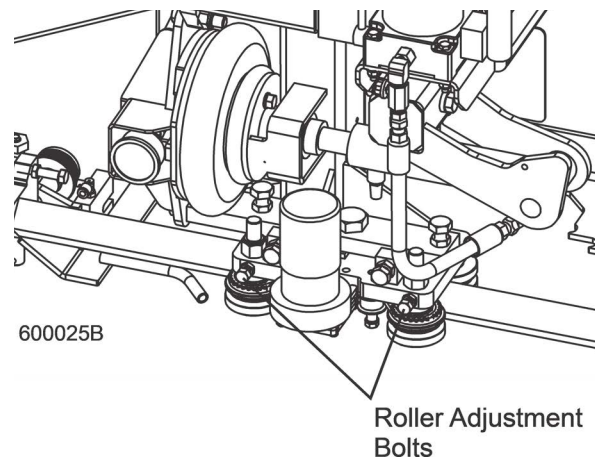

FIG. 7-3

6. With the arm adjusted 1/2" (13 mm) from fully closed, measure the distance between the blade guide roller flange and the back of the blade.
7. Adjust the blade guide arm to 1/2" (13 mm) from fully open and remeasure the distance from the roller flange to the back of the blade.

The two measurements should be the same. If not, adjust the inner rollers in or out to tilt the arm horizontally.

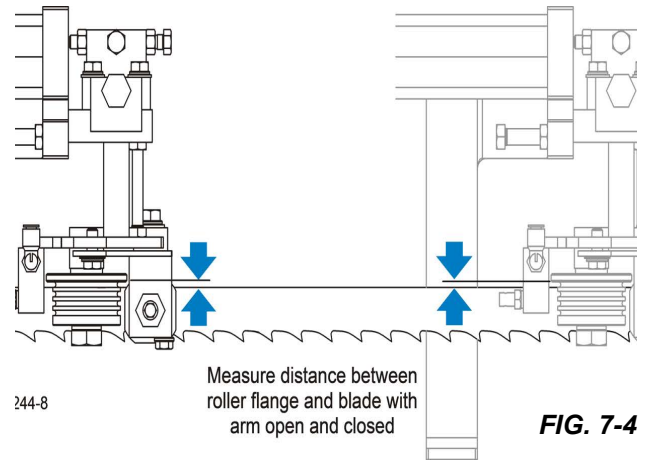

FIG. 7-4

8. Loosen the horizontal adjustment bolt jam nuts.
 - a. To tilt the arm in toward the blade, loosen the rear bolt and tighten the front bolt.
 - b. To tilt the arm out away from the blade, loosen the front bolt and tighten the rear bolt.
 - c. Retighten the jam nuts and recheck the blade guide arm horizontal tilt.

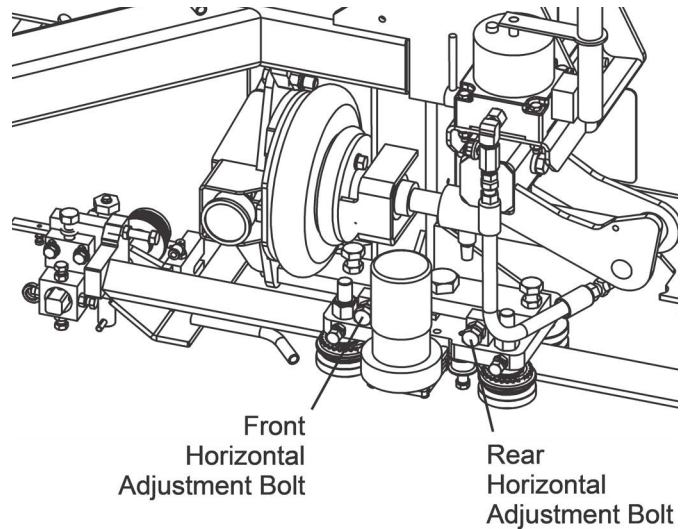

FIG. 7-5

9. Check the vertical tilt of the blade guide arm.
10. Move the saw carriage so the blade guide arm is positioned over a bed rail.
11. With the arm 1/2" (15 mm) from fully closed, raise or lower the saw head until the bottom of the blade guide block is 15" (375 mm) from the top of the bed rail.
12. Adjust the blade guide arm to 1/2" (15 mm) from fully open.
13. Measure the distance from the bottom of the blade guide mounting block to the bed rail. This measurement should be 15" (376.5 mm).

If the measurements are not the same, adjust the blade guide arm vertically.

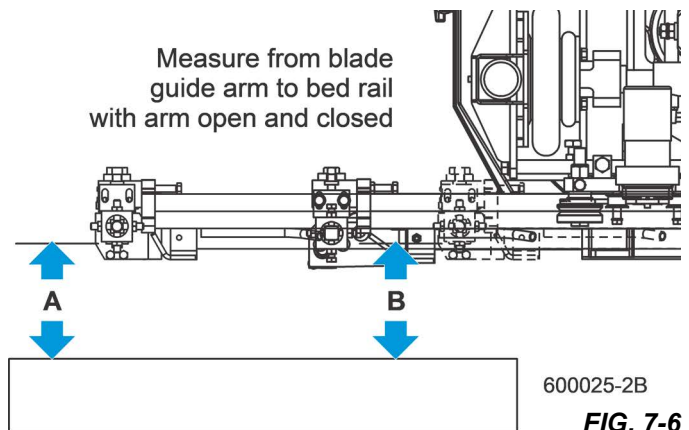

FIG. 7-6

14. Loosen the vertical adjustment bolt jam nuts.
 - a. To tilt the blade guide arm down, loosen the rear bolt and tighten the front bolt.
 - b. To tilt the blade guide arm up, loosen the front bolt and tighten the rear bolt.
 - c. Retighten the jam nuts and recheck the blade guide arm vertical tilt.

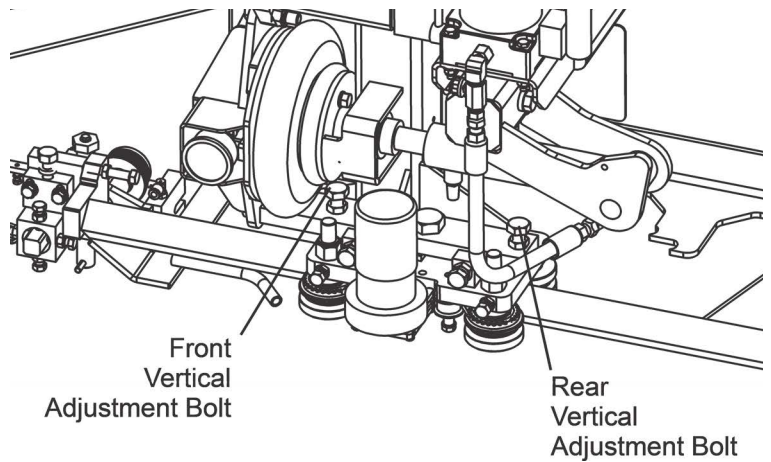

FIG. 7-7

Blade Guide Vertical Tilt Alignment

The blade guides should be adjusted properly in the vertical plane. If the blade guides are tilted vertically, the blade will try to travel in the tilted direction.

A Blade Guide Alignment Tool (BGAT) is provided to help you measure the vertical tilt of the blade.

1. Open the adjustable blade guide arm 1/2" (13 mm) from full open.
2. Clamp the alignment tool on the blade.
3. Position the tool close to the outer blade guide roller.
4. Be sure the tool does not rest on a tooth or burr, and is lying flat on the blade.
5. Move the carriage so that the front end of the tool is positioned above the bed rail.
6. Measure the distance from the bed rail to the bottom edge of the tool.
7. Move the carriage so that the back end of the tool is positioned above the bed rail.
8. Measure the distance from the bed rail to the bottom edge of the tool.
9. If the measurement from the tool to the bed rail is not equal within 1/32" (.75 mm), adjust the vertical tilt of the outer blade guide roller.
10. Loosen one set screw at the side of the blade guide assembly.

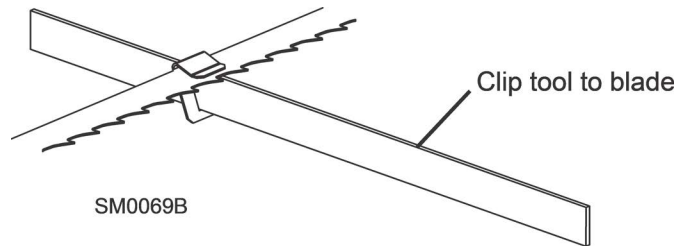

FIG. 7-8

11. Loosen the jam nuts on the top and bottom vertical tilt adjustment screws.
 - a. To tilt the roller up, loosen the bottom screw and tighten top screw.
 - b. To tilt the roller down, loosen the top screw and tighten the bottom screw.
 - c. Tighten the jam nuts and recheck the tilt of the blade.

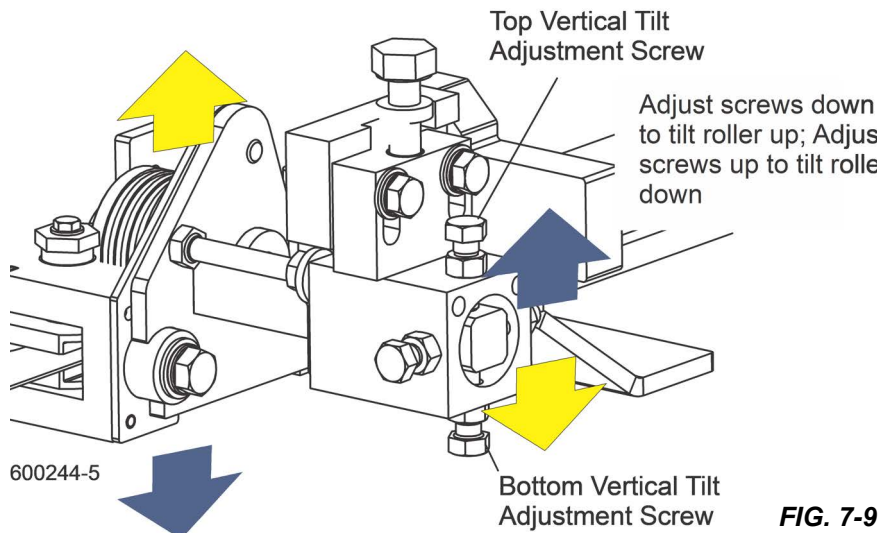

FIG. 7-9

12. Move the blade guide alignment tool close to the inner blade guide roller assembly and repeat the above steps.
13. Adjust the vertical tilt of the inner blade guide if necessary.
14. After adjusting the vertical tilt of the blade guides, recheck the blade deflection and adjust if necessary.

Blade Guide Horizontal Tilt Adjustment

If the blade guides are tilted in the wrong direction horizontally, the back of the blade may contact the flange as the roller is spinning down, causing it to push the blade away from the guide roller.

1. Remove the blade guide alignment tool from the blade and adjust the blade guide arm halfway in.
2. Remove the clip from the blade guide alignment tool. Place the tool against the face of the outer blade guide roller.
3. Measure between the back edge of the blade and the tool at the end closest to the inner blade guide ("B").
4. Measure between the back edge of the blade and the other end of the tool ("A").

The roller should be tilted slightly to the left ('A' 1/8" [3 mm] less than 'B' ±1/8" [3 mm]).

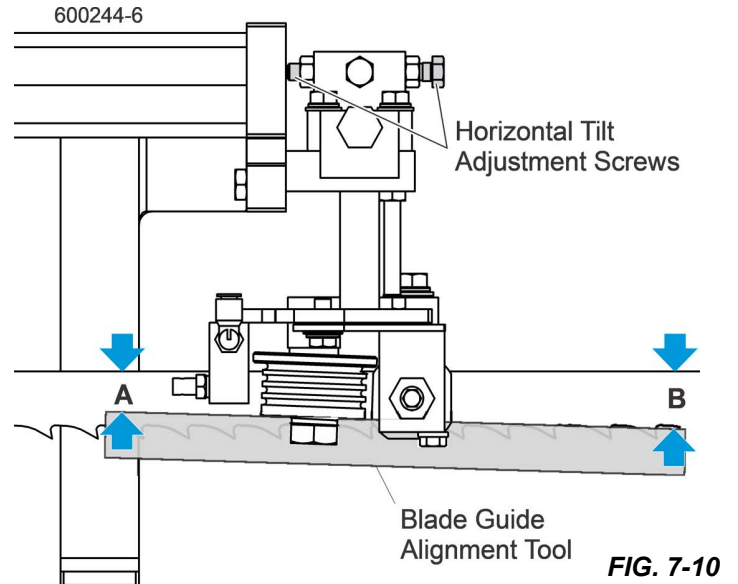

5. Loosen the jam nuts on the horizontal tilt adjustment screws.
 - a. To tilt the roller left, loosen the right screw and tighten left screw.
 - b. To tilt the roller right, loosen the left screw and tighten the right screw.
 - c. Tighten the jam nuts and recheck the tilt of the blade.
6. Repeat the above steps for the inner blade guide roller assembly.

NOTE: Once the blade guides have been adjusted, any cutting variances are most likely caused by the blade.

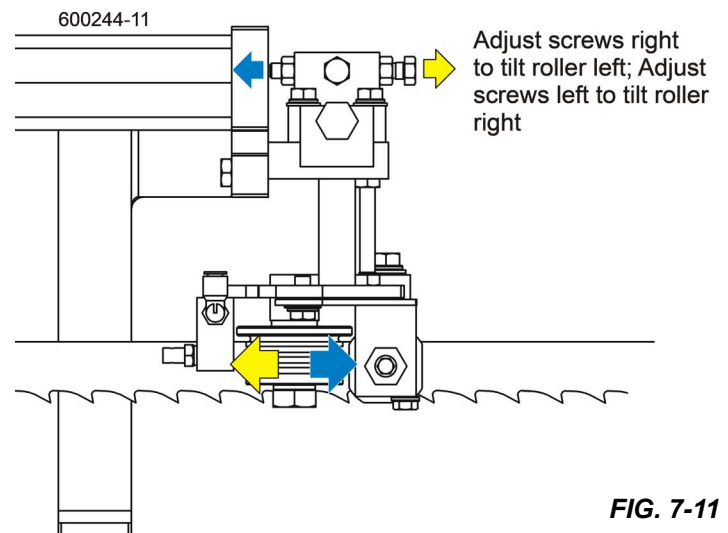

Blade Guide Flange Spacing

Each blade guide must be adjusted so the roller flange is the correct distance from the back edge of the blade. If the flange is too close to or too far from the blade, the sawmill will not cut accurately.

HINT: When adjusting blade guide spacing, loosen the top set screw and one side set screw only. This will ensure horizontal and vertical tilt adjustments are maintained when the adjustment screws are retightened.

1. Measure the distance between the flange on the outer blade guide roller to the back edge of the blade.

This distance should measure 1/8" (3.0 mm). Adjust the roller back or forward if necessary.

2. Loosen the top and one side screw shown.
3. Back the stop bolt out of the way if necessary.
4. Tap the blade guide forward or backward until properly positioned.
5. Retighten the screws and jam nuts.
6. Adjust the stop bolt against the blade guide assembly.
7. Measure the distance between the flange on the inner blade guide roller to the back edge of the blade.

This distance should measure 1/16" (1.5 mm).

8. Adjust the roller back or forward if necessary.

Manual Side Support Alignment

Logs and boards are clamped against the side supports when sawing. The sides supports must be square to the bed to ensure square lumber.

1. Swing a side support down and measure between the face of the support and the main bed tube.

The distance at the top of the side support ('B') should be equal to or no more than 1/32" (0.8 mm) greater than the distance at the base of the side support ('A').

2. Adjust the horizontal tilt of the side support if necessary.
3. Loosen the two adjustment plate mounting bolts.
4. Use a mallet to move the plate until the side support is parallel to the bed tube in the horizontal position.
5. Retighten the mounting bolts.
6. Repeat the horizontal check for the remaining side supports. Adjust as necessary.
7. Place square alignment tubes (Part No. S12831 - 2 required) across the bed rails. Swing a side support up so that it is vertical.

8. Pull back at the top of the support to eliminate slack as if a log were being clamped against it.

9. Place a square against the face of the side support.

The side support should be square or slightly tilted forward 1/32" (0.8 mm).

10. Adjust the vertical tilt of the side support if necessary.

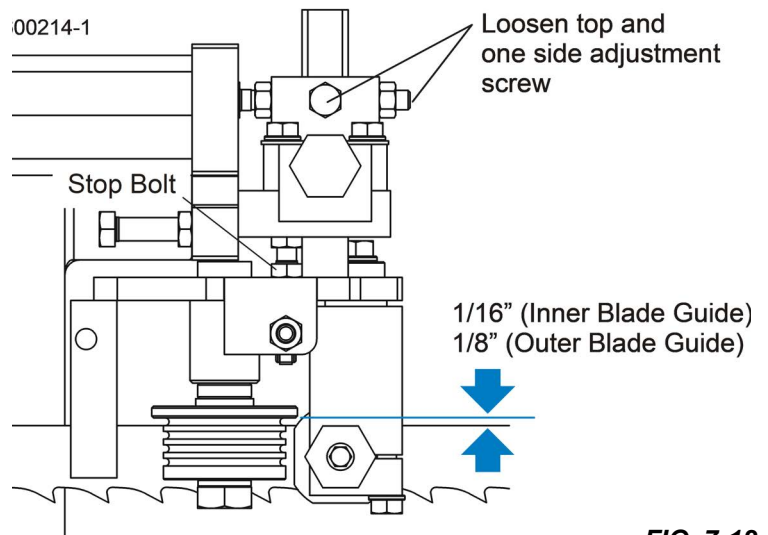

FIG. 7-12

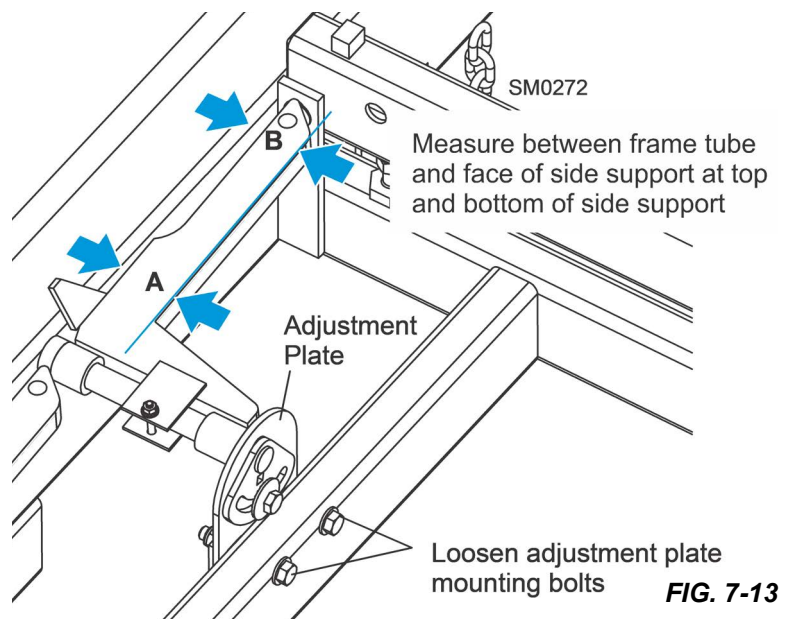

FIG. 7-13

11. Loosen the side support mounting bolt.
12. Use a 3/8" ratchet to rotate the pin until the side support is square to the bed.
13. Repeat the vertical check for the remaining side supports and adjust as necessary.

Hydraulic Side Support Alignment

1. Place the square against the face of the side support.

The side support should be square or slightly tilted forward 1/32" (0.8 mm).

2. Adjust the vertical tilt of the side support if necessary.

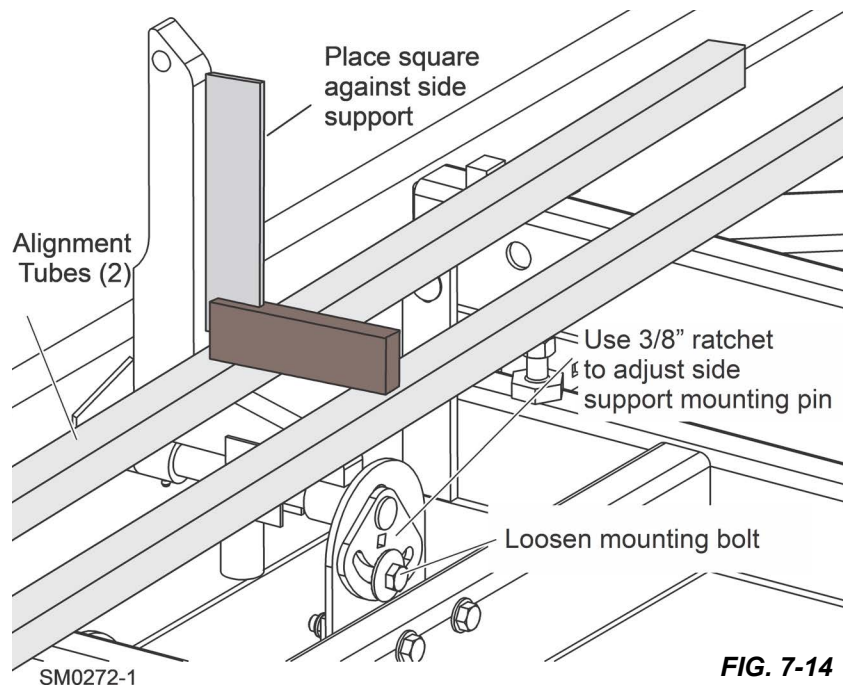

FIG. 7-14

3. Loosen the top jam nut.
4. Adjust the two lower jam nuts up to tilt the side support back.
5. Adjust the two lower jam nuts down to tilt the side support forward.
6. Retighten the top jam nut and repeat for the other hydraulic side support.

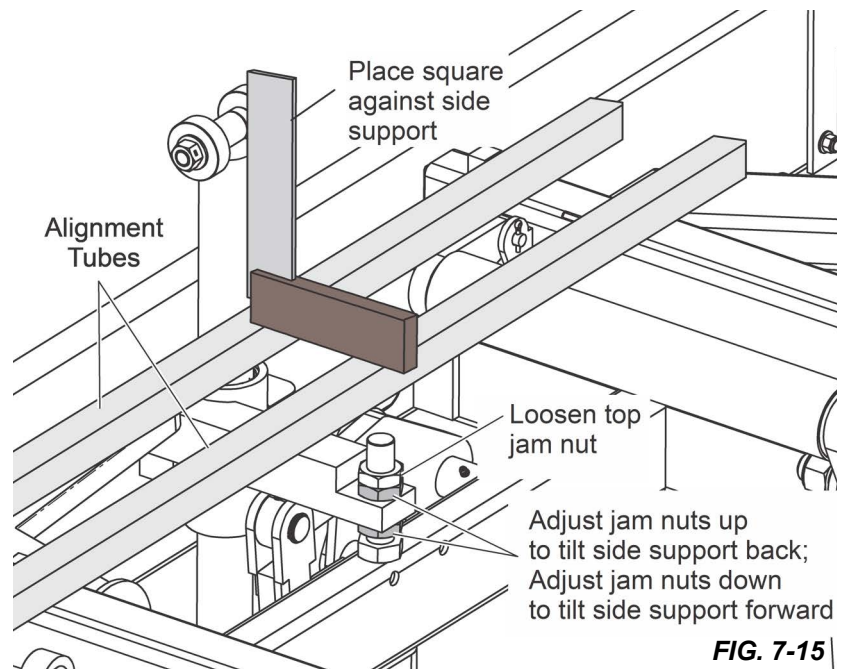

FIG. 7-15

7.2 Complete Alignment Procedure

Frame Setup

Before performing the following alignment procedures, setup the mill on firm, level ground.

If your sawmill is stationary, with no trailer axle, shim the feet so the weight of the sawmill is evenly supported.

If your sawmill has a trailer axle and adjustable outriggers, adjust the outriggers as follows:

Adjust the front and third outriggers on the main frame tube down just enough to lift weight from the trailer tire.

Adjust the two outer outriggers down just so they touch the ground but do not bear weight.

See [SECTION 3](#) for additional setup information.

Blade Installation

1. Remove the blade and replace the blade wheel belts.

New blade wheel belts are required to perform the complete alignment procedure.

2. Blow sawdust off of the blade guide assemblies. Remove sawdust from the blade housings.
3. Remove the blade guide assemblies.

NOTE: To remove the blade guide assemblies and maintain the tilt adjustments, only loosen one side screw and the top screw. Leaving the other side screw and bottom screw in position will insure you will return the rollers to their original tilt adjustment.

4. Adjust the outer blade guide arm in or out until the outer blade guide is approximately 24" from the inner blade guide.
5. Install a new blade and apply the appropriate tension ([See Section 3.4](#)).
6. Close the blade housing cover and make sure all persons are clear of the saw head.
7. Start the engine (or motor).
8. Engage the blade, rotating the blade until the blade positions itself on the wheels.



WARNING! Do not spin the blade wheels by hand. Spinning the blade wheels by hand may result in serious injury.

9. Disengage the blade.
10. Turn the engine off and remove the key.

Blade Wheel Alignment

The blade wheels should be adjusted so they are level in the vertical and horizontal planes. If the blade wheels are tilted up or down, the blade will want to travel in the tilted direction. If the blade wheels are tilted horizontally, the blade will not track properly on the wheels.

1. Use the blade guide alignment tool to check the vertical alignment of each blade wheel.
2. Attach the tool to the blade near the inner blade guide mount.
3. Be sure the tool does not rest on a tooth or burr, and is lying flat against the bottom of the blade.
4. Move the saw carriage so the front end of the tool is positioned over the first bed rail.
5. Measure from the bottom of the tool to the top surface of the bed rail.
6. Move the saw carriage so the rear of the tool is positioned over the bed rail.

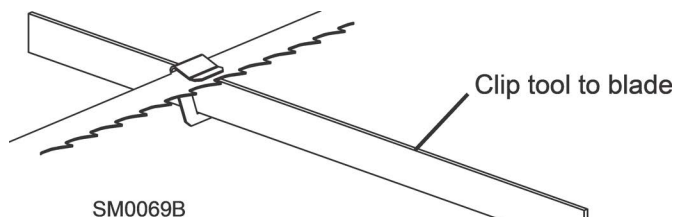

FIG. 7-16

7. Repeat measuring from the bottom of the tool to the bed rail.

If the two measurements differ by more than 1/16" (1.5 mm), adjust the vertical tilt of the drive-side blade wheel.

8. Use the vertical adjustment screws to adjust the drive-side blade wheel.
 - a. To tilt the wheel down, loosen the top adjustment screw one quarter turn.
 - b. Loosen the jam nut on the bottom adjustment screw and tighten the screw.
 - c. Tighten the top and bottom jam nuts.
 - d. To tilt the wheel up, loosen the bottom adjustment screw one quarter turn.
 - e. Loosen the jam nut on the top adjustment screw and tighten the screw.
 - f. Tighten the top and bottom jam nuts.

Adjust vertical adjustment screws up to tilt drive-side blade wheel down; Adjust screws down to tilt wheel up

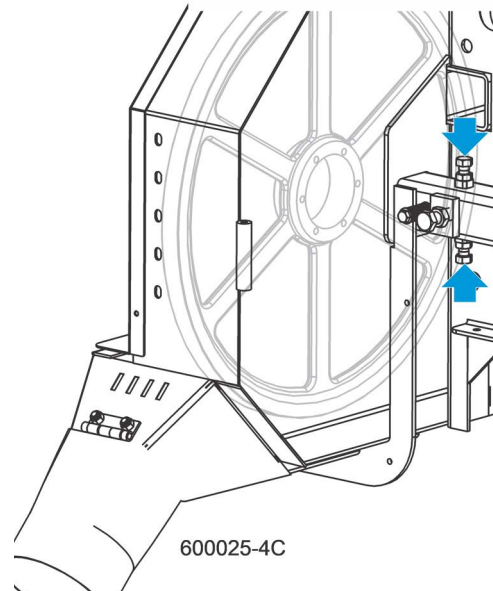

FIG. 7-17

9. Recheck the vertical tilt of the drive-side blade wheel with the blade guide alignment tool.
10. Readjust the blade wheel as necessary until the front and rear of the tool are the same distance from the bed rail (within 1/16" [1.5 mm]).
11. Remove the tool from the blade and reattach it near the outer blade guide assembly.
12. Measure from the tool to the bed rail at both ends of the tool.
13. If the measurements at the front and rear ends of the tool differ by more than 1/16" (1.5 mm), adjust the vertical tilt of the idle-side blade wheel.
14. Use the vertical adjustment screws to adjust the idle-side blade wheel.
 - a. To tilt the wheel up, loosen the bottom adjustment screw one quarter turn.
 - b. Loosen the jam nut on the top adjustment screw and tighten the screw.
 - c. Tighten the top and bottom jam nuts.
 - d. To tilt the wheel down, loosen the top adjustment screw one quarter turn.
 - e. Loosen the jam nut on the bottom adjustment screw and tighten the screw.
 - f. Tighten the top and bottom jam nuts.

Adjust vertical adjustment screws up to tilt idle-side blade wheel down; Adjust screws down to tilt wheel up

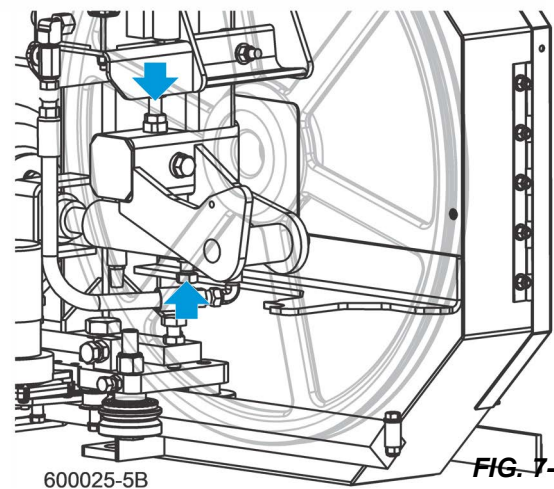

FIG. 7-18

15. Recheck the vertical tilt of the idle-side blade wheel with the blade guide alignment tool.
16. Readjust the blade wheel as necessary until the front and rear of the tool are the same distance from the bed rail (within 1/16" [1.5 mm]).
17. Check the position of the blade on the idle-side blade wheel.

The horizontal tilt of the blade wheel should be adjusted so that the gullet of an 1-1/4" blade is 1/8" (3 mm) out from the front edge of the wheel ($\pm 1/16$ [1.5 mm]). The gullet of an 1-1/2" blade should be 3/16" (4.5 mm) out from the front edge of the wheel ($\pm 1/16$ [1.5 mm]). Do not let the teeth ride on the wheels.

1. Use the cant control adjustment to adjust the idle-side blade wheel.

If the blade is too far forward on the wheel, turn the cant control counterclockwise.

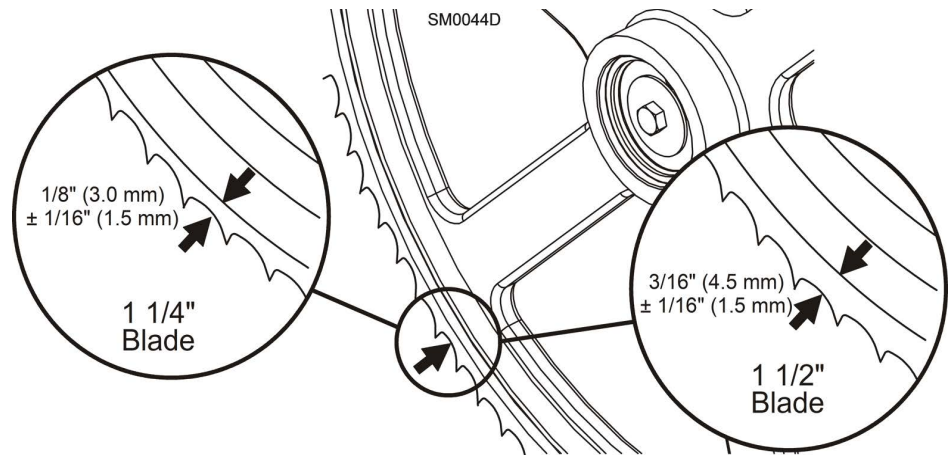

FIG. 7-19

If it is too far back on the wheel, turn the cant control clockwise.

2. Check the position of the blade on the drive-side blade wheel.

The blade should be positioned on the wheel as described for the idle-side blade wheel.

3. Adjust the drive-side blade wheel if necessary.
4. Use the horizontal adjustment screw to adjust the drive-side blade wheel by loosening the top vertical screw to allow movement of the drive shaft.

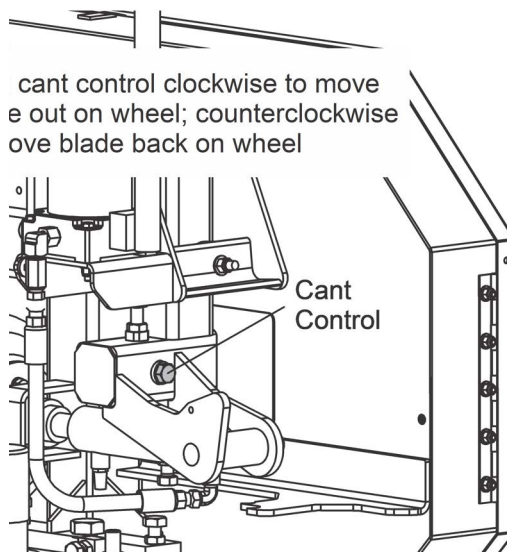

FIG. 7-20

NOTE: To move the blade back on the wheel, loosen the jam nut and turn the horizontal adjustment screw clockwise one quarter turn. To move the blade out on the wheel, loosen the jam nut and turn the horizontal adjustment screw counterclockwise one quarter turn.

5. Repeat adjustments in quarter-turn increments until the blade tracks properly on the drive-side blade wheel.
6. Tighten the horizontal adjustment screw jam nut and the top vertical screw.

Track Roller Adjustment

Making these adjustments correctly will insure the saw carriage travels smoothly along the track and blade will remain parallel with the bed frame.

1. Using the feed controls, move the saw carriage so that the blade is positioned over the front pivot end rail.
2. Check the lower track rollers.

The front roller and the two rear rollers should touch the rail so that you cannot spin them by hand. If the rollers are not adjusted evenly and you can spin one by hand, use the adjustment bolts to adjust the roller.

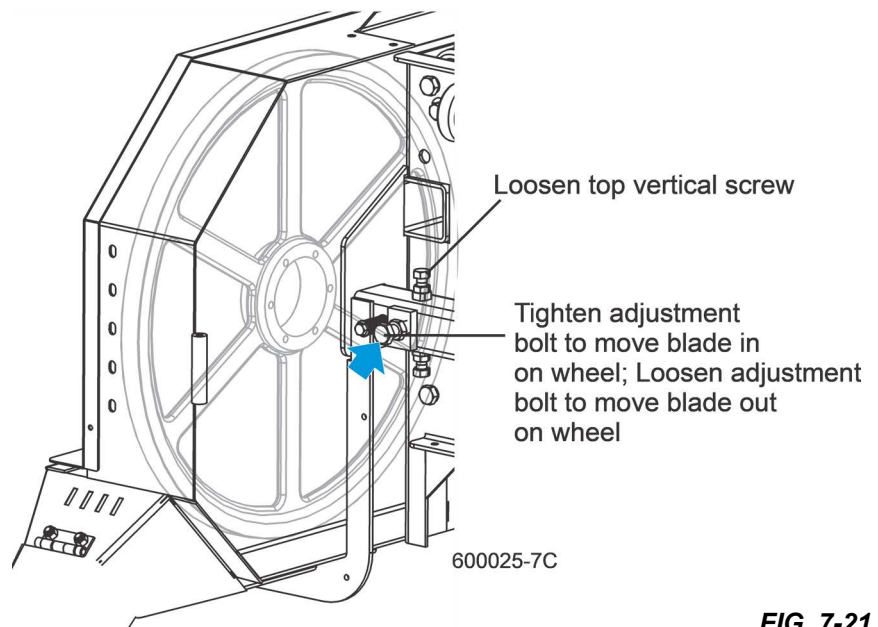

FIG. 7-21

3. Loosen the four retaining plate bolts.
4. Back out the stop bolt and tighten the adjustment bolt to move the track roller(s) toward the rail.
5. When the roller touches the rail so you cannot spin it by hand, retighten the stop bolt and the retaining plate bolts.
6. Observe the middle upper and lower track rollers as you move the saw carriage down the track.

The middle rollers should touch the rail throughout most of the saw carriage travel.

7. Be careful not to tighten the rollers so they cause the carriage to bind as it travels down the track.
8. If the rollers do not spin at least half the distance of the track, tighten them as described above.
9. Open the adjustable blade guide arm to within 1/2" (15 mm) of full open.

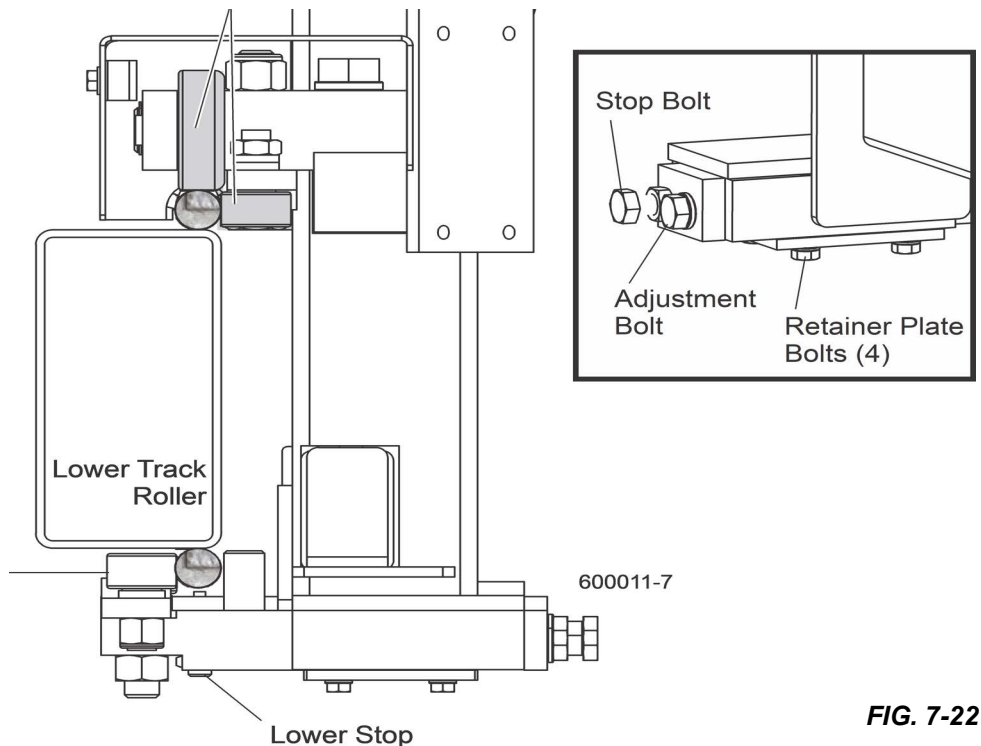

FIG. 7-22

10. Move the carriage back to the front pivot end rail.
11. Raise the cutting head until the bottom of the blade is 17" (400 mm) above the outside of the pivot rail support by actual measurement with a tape or ruler.
12. Move the carriage forward to check the distance to the blade at the inside of the pivot rail support.

All measurements should be equal within 1/32" (0.8 mm).

13. After the lower track rollers are adjusted properly, adjust the upper and lower stop screws.
14. Tighten each screw until it just touches the rail.
15. Back the screw off 1/2 turn.

The gap will be approximately 1/32" (0.8mm).

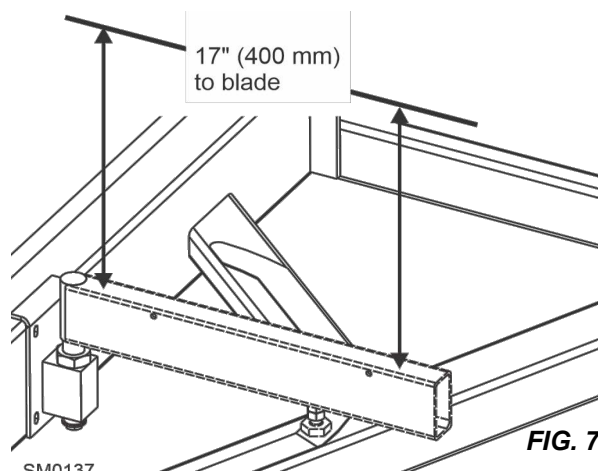

CAUTION! It is important that the lower stop bolts are properly adjusted to secure the carriage on the track rail. Failure to properly adjust the stop bolts can cause saw head damage, especially during mill transportation.

Bed Rail Adjustment

1. Move the clamp so it is 10" (254mm) from the clamp stop.
2. Adjust the clamp down to its lowest position.
3. Move the saw head forward until it is positioned over the clamp.
4. Raise the saw head until the blade measures 15 5/16" (385 mm) from the clamp at its lowest position.
5. Adjust the front pivot rail 90° to the main bed tube.
6. Move the saw head to center the blade over the front pivot bed rail.
7. Measure the distance from the top of the pivot rail to the bottom of the blade. Make this measurement at each end of the pivot rail.

The two measurements should be 15" (375 mm).

8. Loosen the locking set screws and turn the inner height adjustment nut to adjust the height of the inner end of the pivot rail.
9. Loosen the jam nut and turn the outer adjustment bolt to adjust the height of the outer end of the pivot rail.
10. Move the saw head so the blade is positioned over the center of the front main bed rail.
11. Measure the distance between the bottom of the blade and the bed rail at each end of the bed rail.

The bed rail should measure 15" (375 mm) from the blade at each end of the rail.

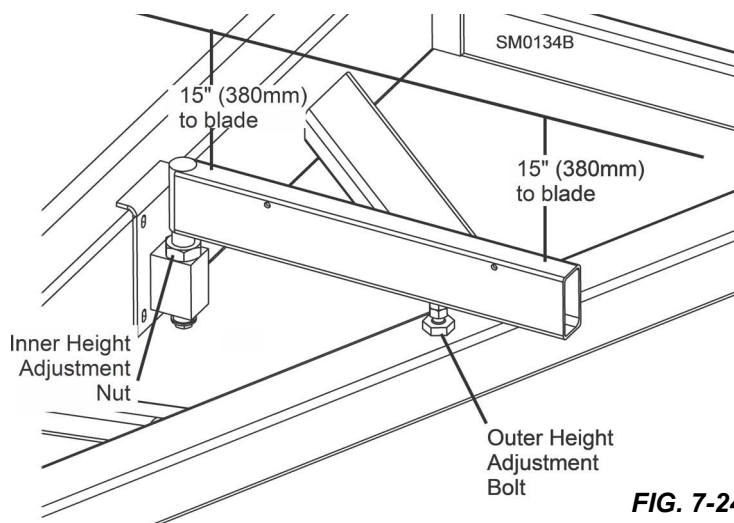

12. Loosen the bed rail clamping bolts and turn the adjustment bolts to move the bed rails to the blade if necessary.
13. Retighten the clamping bolts and adjustment bolt jam nuts.
14. Without adjusting the saw head height, check the three remaining main bed rails and the rear pivot rail.
15. Adjust them so that all measure the same distance from the blade at both ends of the bed rail.

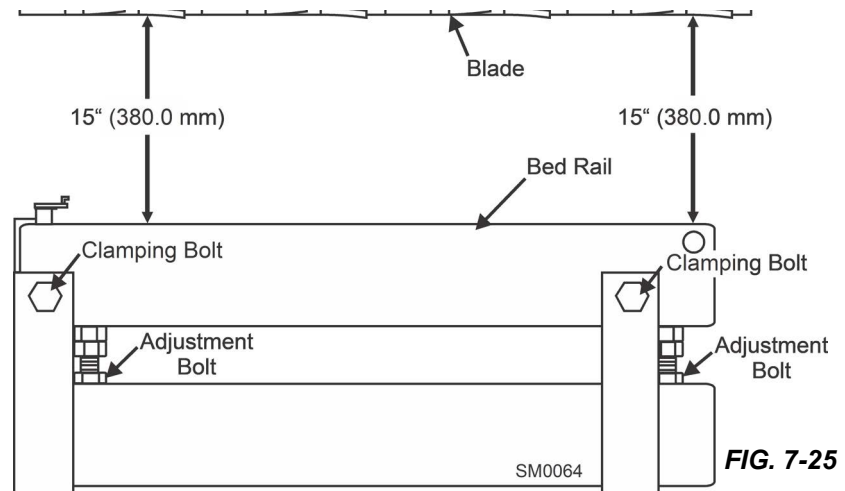

FIG. 7-25

Blade Guide Installation

Each Wood-Mizer sawmill has two blade guide assemblies that help the blade maintain a straight cut. The two blade guide assemblies are positioned on the saw head to guide the blade on each side of the material being cut.

One blade guide assembly is mounted in a stationary position on the drive side of the saw head. This assembly is referred to as the "inner" blade guide assembly.

The other blade guide assembly is mounted on the idle side of the saw head. It is referred to as the "outer" assembly and is adjustable for various widths of materials to be processed.

NOTE: Before installing the blade guide assemblies, remove the blade guide adjusting screws and apply a lubricating oil such as 10W30 or Dexron III to each screw. This will prevent the screws and threaded holes from corroding and make screw adjustments easier.

1. Inspect the guide blocks and repair or replace as necessary. Remove the blade from the sawmill.
2. Loosen the top block clamp bolt and mounting bolt.
3. Turn the adjustment bolt counterclockwise to raise the top block all the way up.
4. Remove the bottom guide block from each blade guide assembly and install the provided alignment bar.
5. Install each blade guide assembly to the mounting blocks and push all the way back.
6. Install, tension and track a new blade.
7. Adjust the outer blade guide assembly so the roller flange is 1/8" from the back of the blade.
8. Adjust the inner blade guide assembly so the roller flange is 1/16" from the blade.
9. Tighten the two previously-loosened tilt adjustment screws to secure the blade guide assembly.
10. Turn the top adjustment bolt clockwise to raise the blade guide assembly so the roller does not contact the blade.

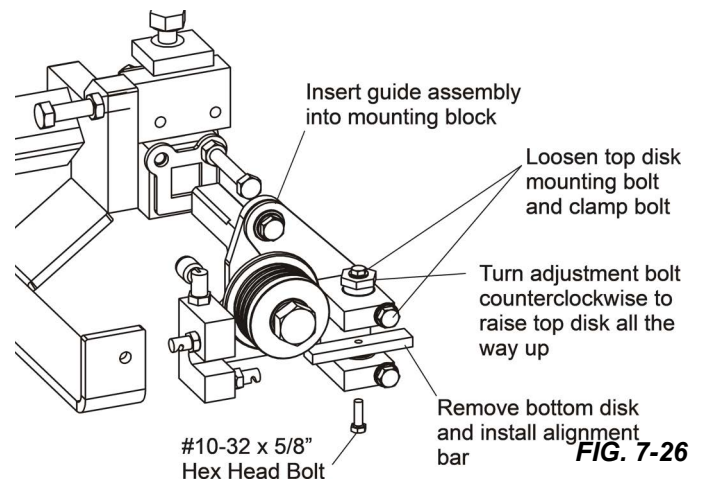

FIG. 7-26

NOTE: Before adjusting the top bolt, unload pressure on the bolt by turning 1/2 turn in the opposite direction it was last adjusted.

11. With the roller flange positioned properly from the back of the blade, adjust the stop bolt so it touches the blade guide bracket.

Blade Guide Arm Alignment

The blade guide arm moves the outer blade guide in and out. If the arm becomes loose, the blade guide will not deflect the blade properly, causing inaccurate cuts. A loose blade guide arm can also cause blade vibration.

1. Adjust the blade guide arm in to 1/2" (13 mm) from fully closed.
2. Manually try to move the arm up and down.

If you can move the arm by hand, you will need to tighten the arm rollers.

3. Loosen the jam nuts and turn the adjustment bolts in to tighten the blade guide arm rollers.
4. Retighten the jam nuts.
5. After tightening the blade guide arm rollers, check that the arm is aligned properly.

6. With the arm adjusted 1/2" (13 mm) from fully closed, measure the distance between the blade guide roller flange and the back of the blade.
7. Adjust the blade guide arm to 1/2" (13 mm) from fully open and remeasure the distance from the roller flange to the back of the blade.

The two measurements should be the same. If not, adjust the inner rollers in or out to tilt the arm horizontally.

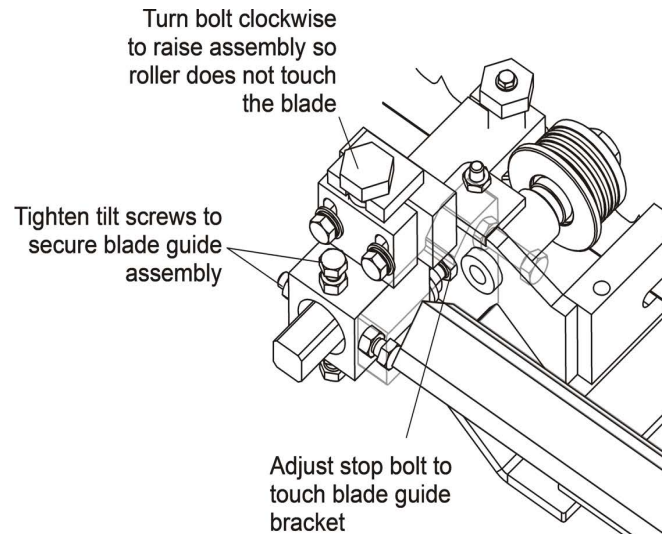

FIG. 7-27

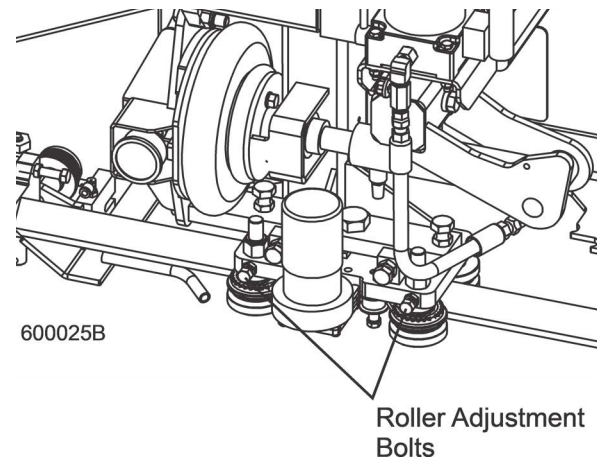

FIG. 7-28

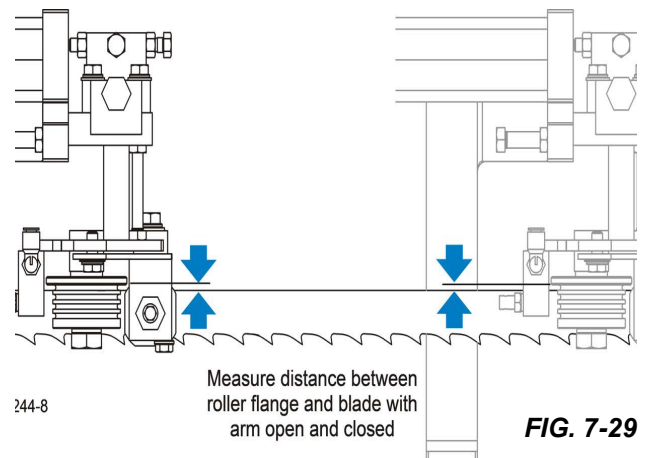

FIG. 7-29

8. Loosen the horizontal adjustment bolt jam nuts.
 - a. To tilt the arm in toward the blade, loosen the rear bolt and tighten the front bolt.
 - b. To tilt the arm out away from the blade, loosen the front bolt and tighten the rear bolt.
 - c. Retighten the jam nuts and recheck the blade guide arm horizontal tilt.
9. Check the vertical tilt of the blade guide arm.
10. Move the saw carriage so the blade guide arm is positioned over a bed rail.
11. With the arm 1/2" (15 mm) from fully closed, raise or lower the saw head until the bottom of the blade guide block is 15" (375 mm) from the top of the bed rail.
12. Adjust the blade guide arm to 1/2" (15 mm) from fully open.
13. Measure the distance from the bottom of the blade guide mounting block to the bed rail. This measurement should be 15" (376.5 mm).

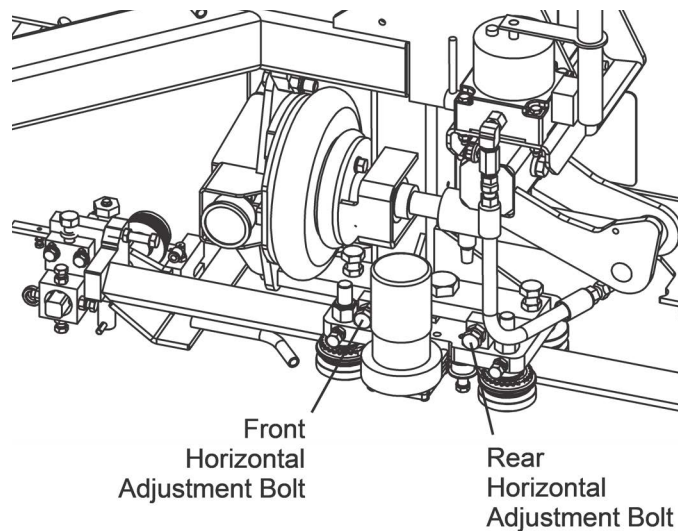

FIG. 7-30

If the measurements are not the same, adjust the blade guide arm vertically.

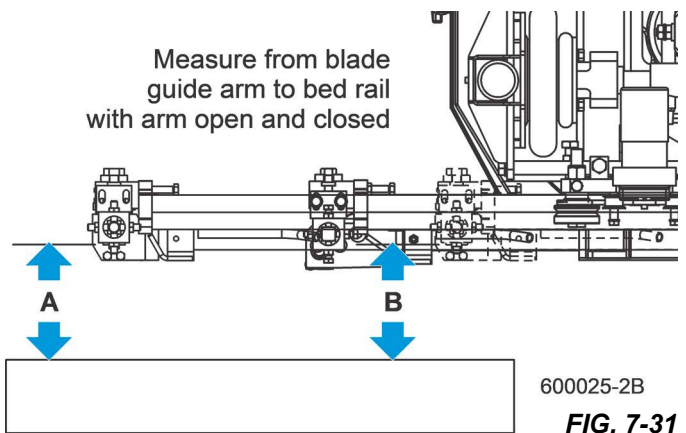

FIG. 7-31

14. Loosen the vertical adjustment bolt jam nuts.
 - a. To tilt the blade guide arm down, loosen the rear bolt and tighten the front bolt.
 - b. To tilt the blade guide arm up, loosen the front bolt and tighten the rear bolt.
 - c. Retighten the jam nuts and recheck the blade guide arm vertical tilt.

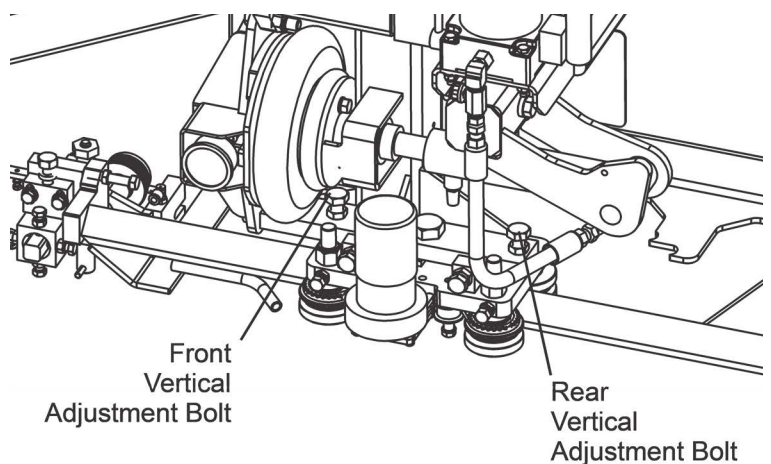

FIG. 7-32

Blade Guide Deflection

Perform the following steps to achieve proper blade deflection with the blade guides.

1. Raise the saw head until the blade is 15" (375 mm) above a bed rail.
2. Measure the actual distance with a tape from the top of the rail to the bottom of the blade.

NOTE: Before adjusting the top bolt, unload pressure on the bolt by turning 1/2 turn in the opposite direction it was last adjusted.

3. Turn the top adjustment bolt counterclockwise to lower the assembly until the blade guide roller deflects the blade down until the bottom of the blade measures 14 3/4" (370 mm) from the bed rail.
4. Repeat for the other blade guide.

Blade Guide Vertical Tilt Alignment

The blade guides should be adjusted properly in the vertical plane. If the blade guides are tilted vertically, the blade will try to travel in the tilted direction.

A Blade Guide Alignment Tool (BGAT) is provided to help you measure the vertical tilt of the blade.

1. Open the adjustable blade guide arm 1/2" (13 mm) from full open.
2. Clamp the alignment tool on the blade.
3. Position the tool close to the outer blade guide roller.
4. Be sure the tool does not rest on a tooth or burr, and is lying flat on the blade.

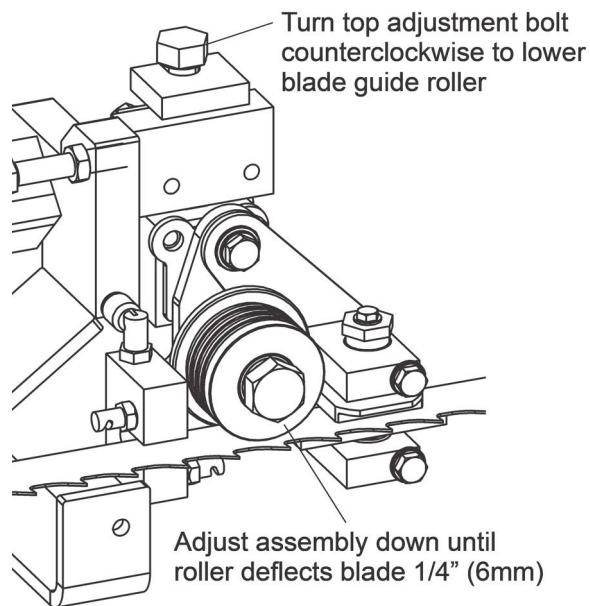

FIG. 7-33

5. Move the carriage so that the front end of the tool is positioned above the bed rail.
6. Measure the distance from the bed rail to the bottom edge of the tool.
7. Move the carriage so that the back end of the tool is positioned above the bed rail.
8. Measure the distance from the bed rail to the bottom edge of the tool.

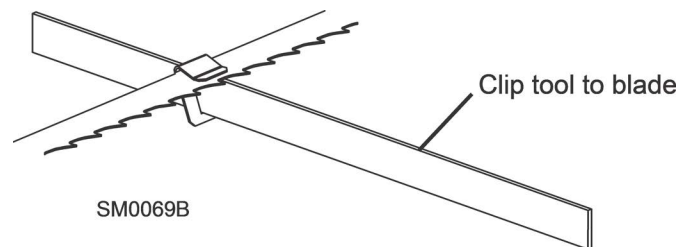

FIG. 7-34

9. If the measurement from the tool to the bed rail is not equal within 1/32" (.75 mm), adjust the vertical tilt of the outer blade guide roller.
10. Loosen one set screw at the side of the blade guide assembly.
11. Loosen the jam nuts on the top and bottom vertical tilt adjustment screws.

- a. To tilt the roller up, loosen the bottom screw and tighten top screw.
- b. To tilt the roller down, loosen the top screw and tighten the bottom screw.
- c. Tighten the jam nuts and recheck the tilt of the blade.

12. Move the blade guide alignment tool close to the inner blade guide roller assembly and repeat the above steps.
13. Adjust the vertical tilt of the inner blade guide if necessary.
14. After adjusting the vertical tilt of the blade guides, recheck the blade deflection and adjust if necessary.

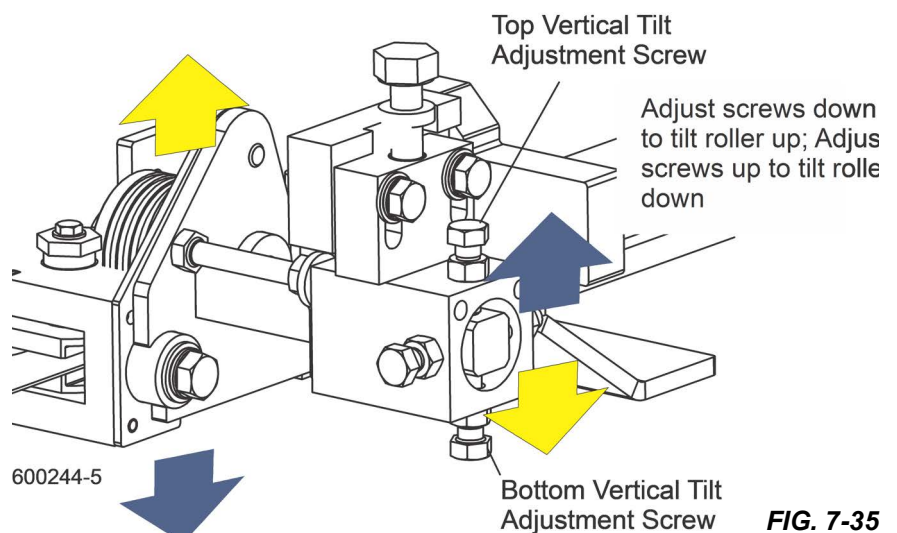

FIG. 7-35

Blade Guide Horizontal Tilt Adjustment

If the blade guides are tilted in the wrong direction horizontally, the back of the blade may contact the flange as the roller is spinning down, causing it to push the blade away from the guide roller.

1. Remove the blade guide alignment tool from the blade and adjust the blade guide arm halfway in.
2. Remove the clip from the blade guide alignment tool. Place the tool against the face of the outer blade guide roller.
3. Measure between the back edge of the blade and the tool at the end closest to the inner blade guide ("B").
4. Measure between the back edge of the blade and the other end of the tool ("A").

The roller should be tilted slightly to the left ('A' 1/8" [3 mm] less than 'B' ±1/8" [3 mm]).

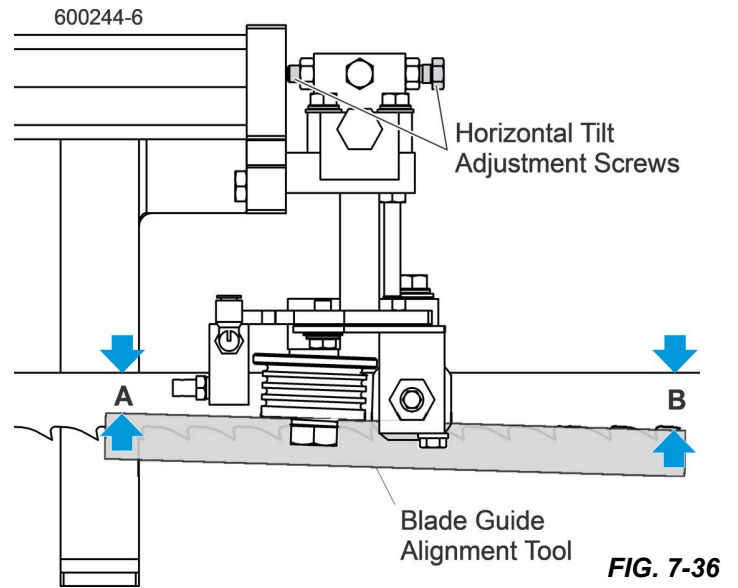

5. Loosen the jam nuts on the horizontal tilt adjustment screws.
 - a. To tilt the roller left, loosen the right screw and tighten left screw.
 - b. To tilt the roller right, loosen the left screw and tighten the right screw.
 - c. Tighten the jam nuts and recheck the tilt of the blade.
6. Repeat the above steps for the inner blade guide roller assembly.

NOTE: Once the blade guides have been adjusted, any cutting variances are most likely caused by the blade.

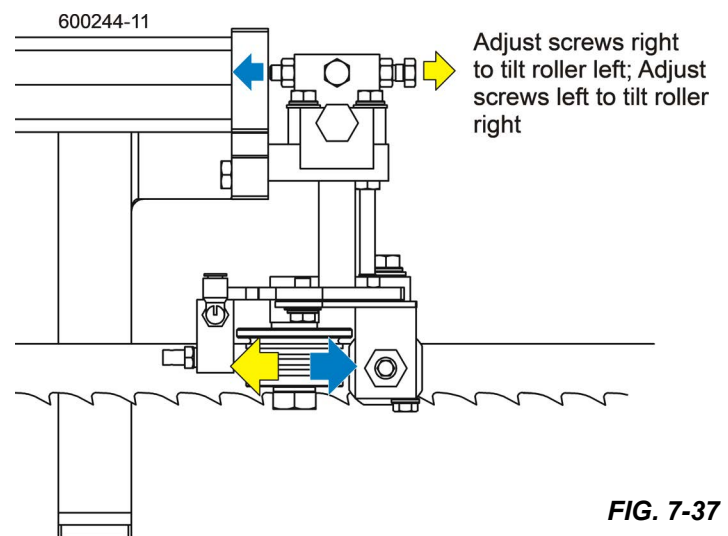

Blade Guide Flange Spacing

Each blade guide must be adjusted so the roller flange is the correct distance from the back edge of the blade. If the flange is too close to or too far from the blade, the sawmill will not cut accurately.

HINT: When adjusting blade guide spacing, loosen the top set screw and one side set screw only. This will ensure horizontal and vertical tilt adjustments are maintained when the adjustment screws are retightened.

1. Measure the distance between the flange on the outer blade guide roller to the back edge of the blade.

This distance should measure 1/8" (3.0 mm). Adjust the roller back or forward if necessary.

2. Loosen the top and one side screw shown.
3. Back the stop bolt out of the way if necessary.
4. Tap the blade guide forward or backward until properly positioned.
5. Retighten the screws and jam nuts.
6. Adjust the stop bolt against the blade guide assembly.
7. Measure the distance between the flange on the inner blade guide roller to the back edge of the blade.

This distance should measure 1/16" (1.5 mm).

8. Adjust the roller back or forward if necessary.

Blade Guide Level

Perform the following adjustments to make sure the blade guide assembly is parallel to the blade.

1. Loosen the alignment bar mounting bolt.
2. Use the provided bottom block adjustment tool to adjust the alignment bar up so the bar is close to, but not touching the bottom of the blade.
3. Retighten the alignment bar mounting bolt.
4. Check that the gap from the alignment bar to the blade is the same along entire length of the bar.
5. Shine a flashlight behind the blade guide assembly to help you see the gap between the bar and the blade.
6. Turn the tilt adjustment jam nuts to pivot the block assembly until the alignment bar is parallel to the blade.
7. Retighten the jam nuts.
8. Repeat for the second blade guide assembly.

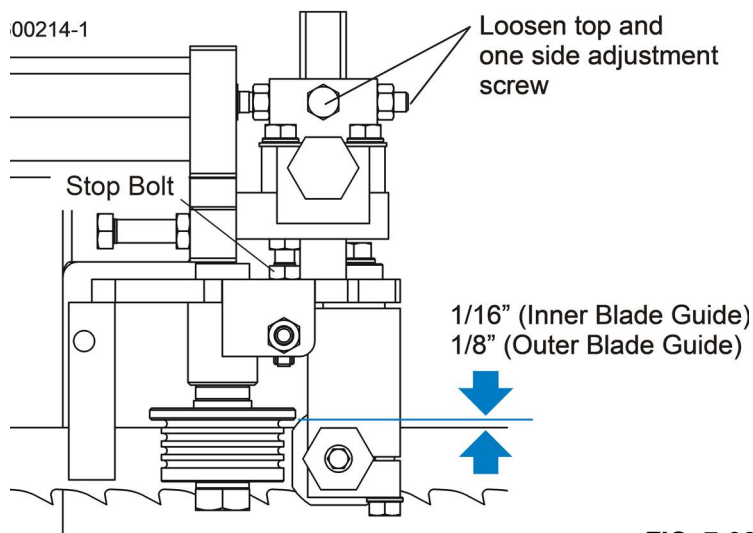

FIG. 7-38

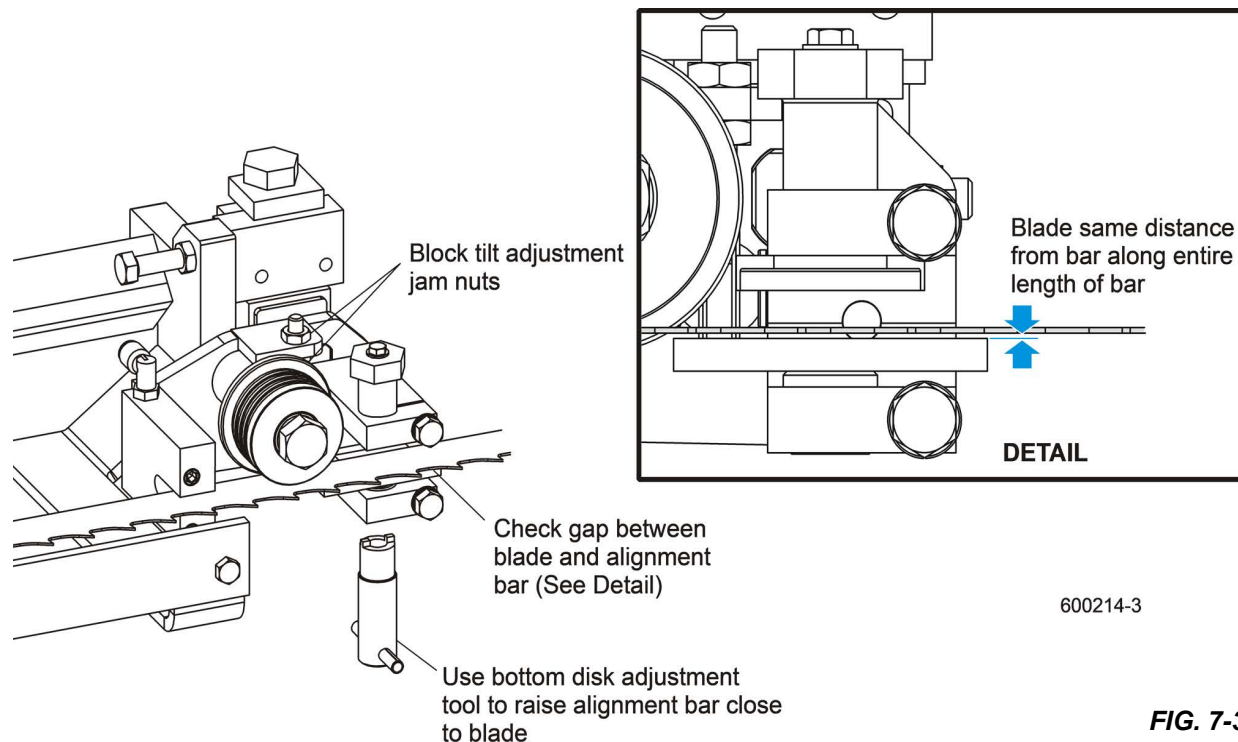

FIG. 7-39

Blade Block Adjustment

1. Remove the blade and remove the alignment bars from the blade guide assemblies.
2. Install new or reconditioned bottom guide blocks to both blade guide assemblies (leave mounting bolts loose).
3. Use the provided bottom block adjustment tool to lower the bottom block all the way down. Install, tension and track the blade.
4. Use the bottom block adjustment tool to raise the bottom block to .008" - .010" (0.2-0.25mm) from the blade.
5. Use the provided shim to set the distance from the block to the blade.
6. Tighten the bottom block mounting bolt and clamp bolt.
7. Turn the top block adjustment bolt clockwise to lower the top block to .008" - .010" (0.2-0.25mm) from the blade (using the shim as a guide).
8. Tighten the top block mounting bolt and clamp bolt.
9. After tightening the clamp bolt, recheck the distance from the top block to the blade and readjust if necessary.

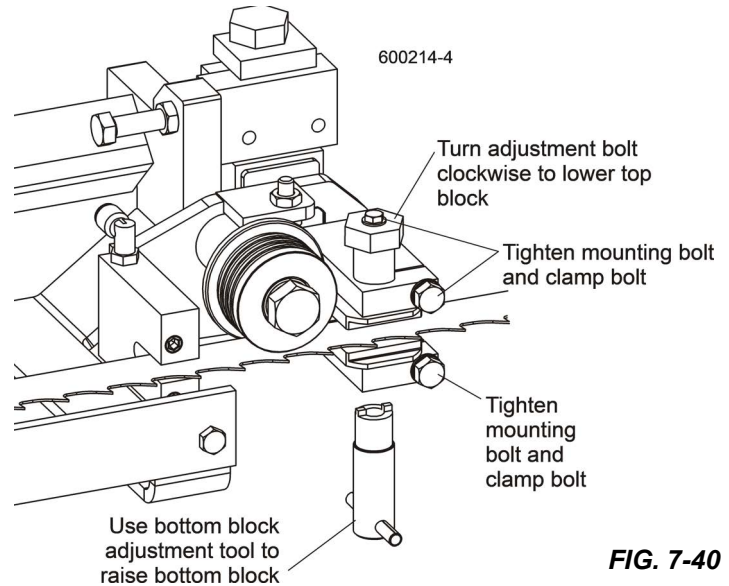

FIG. 7-40

Manual Side Support Alignment

Logs and boards are clamped against the side supports when sawing. The sides supports must be square to the bed to ensure square lumber.

1. Swing a side support down and measure between the face of the support and the main bed tube.

The distance at the top of the side support ('B') should be equal to or no more than 1/32" (0.8 mm) greater than the distance at the base of the side support ('A').

2. Adjust the horizontal tilt of the side support if necessary.
3. Loosen the two adjustment plate mounting bolts.
4. Use a mallet to move the plate until the side support is parallel to the bed tube in the horizontal position.
5. Retighten the mounting bolts.
6. Repeat the horizontal check for the remaining side supports. Adjust as necessary.
7. Place square alignment tubes (Part No. S12831 - 2 required) across the bed rails. Swing a side support up so that it is vertical.
8. Pull back at the top of the support to eliminate slack as if a log were being clamped against it.
9. Place a square against the face of the side support.

The side support should be square or slightly tilted forward 1/32" (0.8 mm).

10. Adjust the vertical tilt of the side support if necessary.

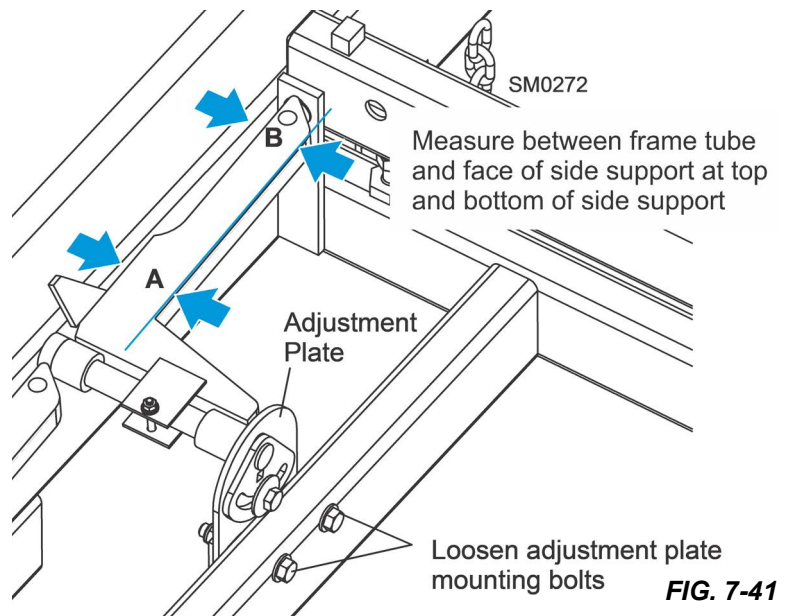

FIG. 7-41

11. Loosen the side support mounting bolt.
12. Use a 3/8" ratchet to rotate the pin until the side support is square to the bed.
13. Repeat the vertical check for the remaining side supports and adjust as necessary.

Hydraulic Side Support Alignment

1. Place the square against the face of the side support.

The side support should be square or slightly tilted forward 1/32" (0.8 mm).

2. Adjust the vertical tilt of the side support if necessary.

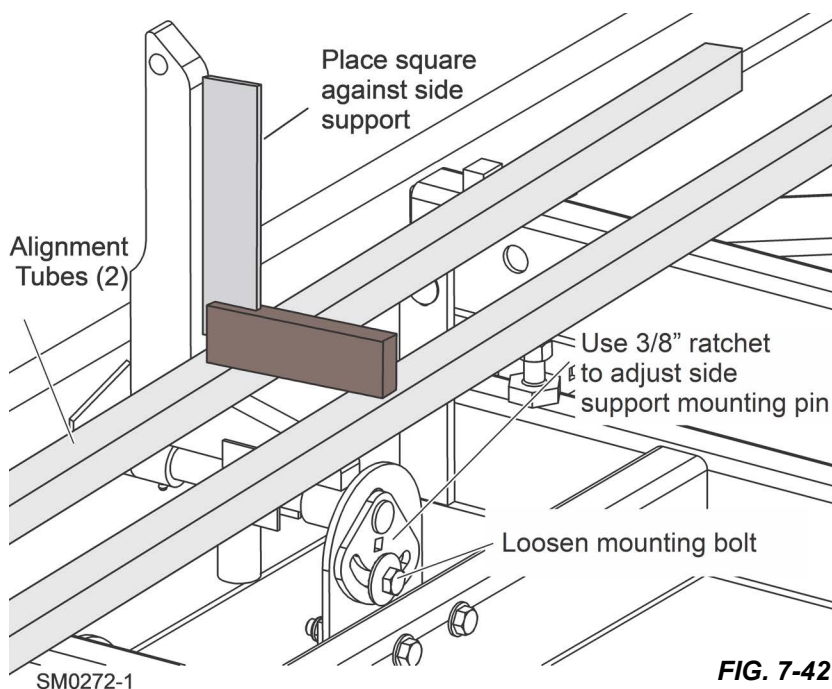

FIG. 7-42

3. Loosen the top jam nut.
4. Adjust the two lower jam nuts up to tilt the side support back.
5. Adjust the two lower jam nuts down to tilt the side support forward.
6. Retighten the top jam nut and repeat for the other hydraulic side support.

Clamp Stop/Stop Bolt Adjustment

1. Once the side supports are aligned, pivot them down to their horizontal position.
2. Tie a string to the stop block at the first bed rail.
3. Stretch the string toward the rear of the frame and tie to the stop block at the last bed rail.

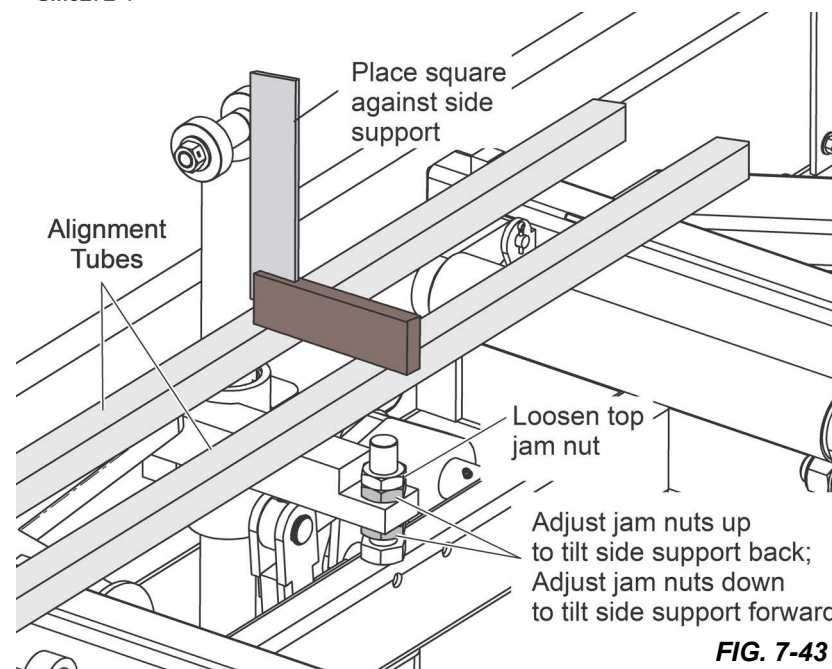

FIG. 7-43

4. Loosen the clamp stop bolts and adjust the clamp stop until it touches the string.
5. Loosen the jam nut and adjust the bolt on the middle-rear bed rail until it touches the string.

Saw Head Tilt

As the blade enters a wide log or cant, the outside of the saw head will drop down slightly. To compensate for the drop, the saw head is adjusted 1/16" (1.5 mm) higher at the outside.

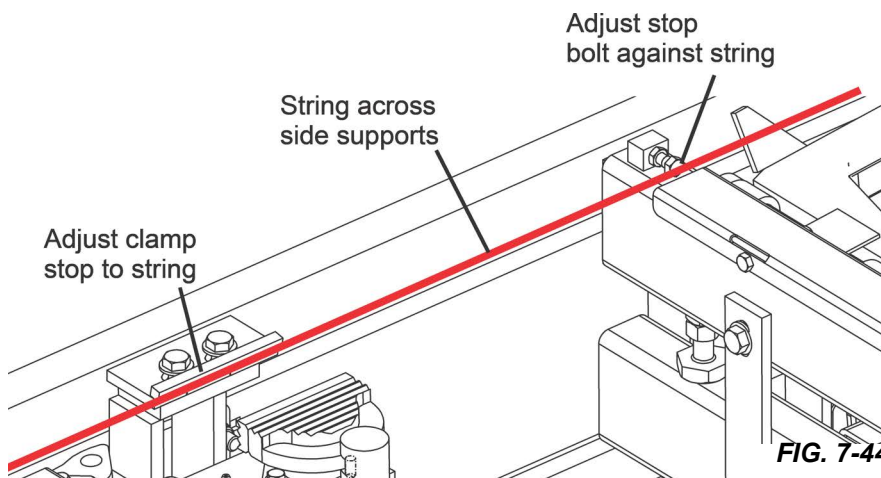

FIG. 7-44

1. Move the saw carriage so the blade is positioned over a bed rail. Adjust the blade guide arm to 1/2" (13 mm) from full open.

The saw head should still be adjusted so the blade is 14 3/4" (375 mm) above the bed rails.

2. Measure from the blade to the bed rail near the outer blade guide assembly.

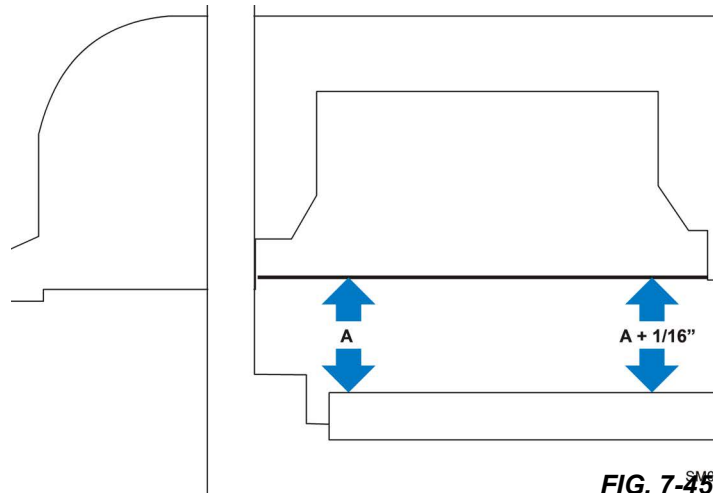

FIG. 7-45

3. Use the bolts located at the bottom of the saw head mast to adjust the saw head tilt.

4. Loosen the two sets of four retaining plate bolts.

NOTE: To raise the outside of the saw head, back the stop bolts out, then tighten the adjustment bolts. To lower the outside of the saw head, loosen the adjustment bolts and tighten the stop bolts.

5. Recheck the measurement from the blade to the bed rails and adjust the stop bolts and adjustment bolts until the outside of the saw head is 1/16" higher than the inside.
6. Retighten the retaining plate bolts.

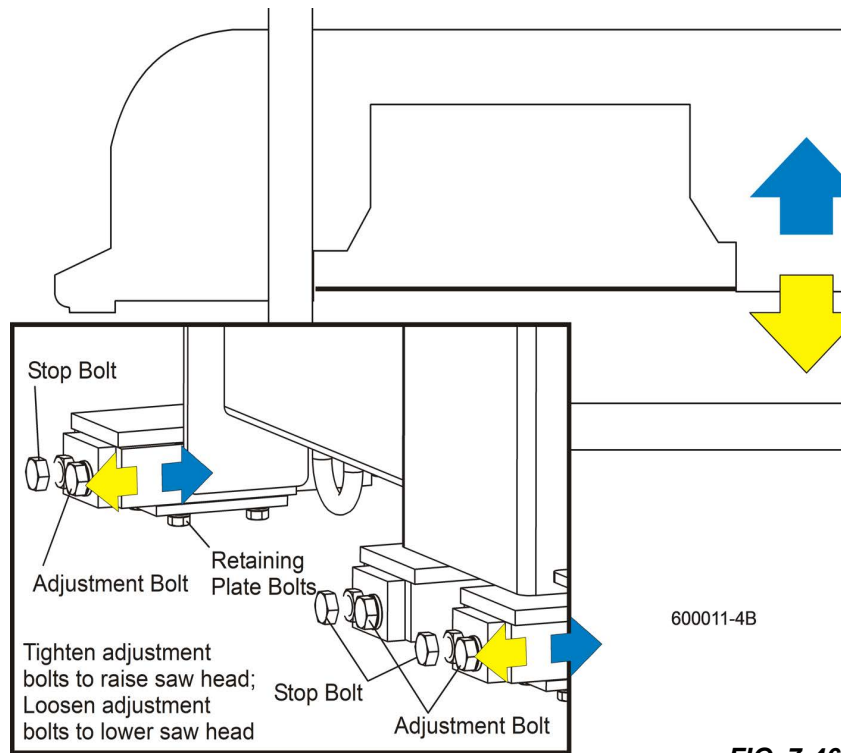

600011-4B

DETAIL OF LOWER TRACK ROLLER ASSEMBLY

FIG. 7-46