

Wood-Mizer[®] Sawmill

Safety, Setup, Operation & Maintenance Manual

LT35HD

rev. A6.16



Safety is our #1 concern! Read and understand all safety information and instructions before operating, setting up or maintaining this machine.

October 2010

Form #1719

California
Proposition 65 Warning



WARNING: Breathing gas/diesel engine exhaust exposes you to chemicals known to the State of California to cause cancer and birth defects or other reproductive harm.

- Always start and operate the engine in a well-ventilated area.
- If in an enclosed area, vent the exhaust to the outside.
- Do not modify or tamper with the exhaust system.
- Do not idle the engine except as necessary.

For more information go to **www.P65warnings.ca.gov**.



WARNING: Drilling, sawing, sanding or machining wood products can expose you to wood dust, a substance known to the State of California to cause cancer. Avoid inhaling wood dust or use a dust mask or other safeguards for personal protection.

For more information go to **www.P65Warnings.ca.gov/wood**.

Active Patents assigned to Wood-Mizer, LLC

Wood-Mizer, LLC has received patents that protect our inventions which are a result of a dedication to research, innovation, development, and design. Learn more at: woodmizer.com/patents

©2022 Wood-Mizer LLC

Printed in the United States of America, all rights reserved. No part of this manual may be reproduced in any form by any photographic, electronic, mechanical or other means or used in any information storage and retrieval system without written permission from

Wood-Mizer, LLC
8180 West 10th Street
Indianapolis, Indiana 46214

Table of Contents

Section-Page

SECTION 1	INTRODUCTION	1-1
1.1	About This Manual.....	1-1
1.2	Getting Service.....	1-1
1.3	Specifications.....	1-1
1.4	Options and Accessories.....	1-1
SECTION 2	GENERAL SAFETY	2-1
2.1	Safety Symbols.....	2-1
2.2	Safety Instructions.....	2-1
2.3	Electrical Lockout Procedures.....	2-3
SECTION 3	SAWMILL SETUP	3-1
3.1	Stationary Sawmill Setup.....	3-1
3.2	Portable Sawmill Setup.....	3-2
3.3	Installing the Blade.....	3-3
3.4	Tensioning The Blade.....	3-4
3.5	Tracking The Blade.....	3-4
3.6	Starting The Engine.....	3-5
SECTION 4	SAWMILL OPERATION	4-1
4.1	Hydraulic Control Operation.....	4-1
4.2	Loading, Turning And Clamping Logs.....	4-2
4.3	Up/Down Operation.....	4-3
4.4	Simple Set Operation.....	4-3
4.5	Blade Guide Arm Operation.....	4-4
4.6	Feed Operation.....	4-4
4.7	Cutting The Log.....	4-5
4.8	Edging.....	4-6
4.9	Blade Height Scale.....	4-6
4.10	Water Lube Operation.....	4-7
4.11	Preparing The Sawmill For Towing.....	4-7
SECTION 5	MAINTENANCE	5-1
5.1	Wear Life.....	5-1
5.2	Blade Guides.....	5-1
5.3	Sawdust Removal.....	5-1
5.4	Carriage Track, Wiper & Scraper.....	5-1
5.5	Vertical Mast Rails.....	5-2
5.6	Miscellaneous.....	5-2
5.7	Blade Wheel Belts.....	5-2
5.8	Drive Belt Adjustment.....	5-2
5.9	Hydraulic System.....	5-4
5.10	Up/Down System.....	5-5
5.11	Power Feed.....	5-5
5.12	Charging The Battery.....	5-6
5.13	Maintenance chart.....	5-8

Table of Contents

Section-Page

SECTION 6	TROUBLESHOOTING GUIDE	6-1
6.1	Sawing Problems.....	6-1
6.2	Electrical Problems.....	6-2
6.3	Power Feed Problems.....	6-3
6.4	Power Feed Variable Feed Rate Switch Test.....	6-3
6.5	Hydraulic Problems.....	6-4
6.6	Hydraulic Pressure Test.....	6-7
6.7	Simple Set Troubleshooting.....	6-8
SECTION 7	SAWMILL ALIGNMENT	7-1
7.1	Routine Alignment Procedure.....	7-1
7.2	Complete Alignment Procedure.....	7-5

Wood-Mizer® LLC Limited Product Warranty



Wood-Mizer LLC ("Warrantor"), an Indiana corporation with its principal place of business at 8180 West Tenth Street, Indianapolis, IN 46214-2400 USA, warrants to the purchaser ("Purchaser") that for the time periods specifically stated herein and subject to the terms, conditions and limitations stated herein, the equipment manufactured by the Warrantor will be free from defects in material and workmanship attributable to Warrantor so long as, during the warranty periods stated herein, the equipment is installed, operated and maintained in accordance with the instructions provided by Warrantor.

PRODUCT	MODEL CLASS	LENGTH OF WARRANTY		EFFECTIVE DATE
		USA & CANADA	NON USA & CANADA	
Portable Sawmills, Resaws, Edgers	LT, LX, HR, EG	Two years	One year	Date of purchase
Portable Sawmills with Chassis	LT28, LT35, LT40, LT50, LT70, LX450	Two years, excluding the chassis, which chassis shall have a five year warranty	One year	
Industrial Sawmills, Resaws, Edgers	WM, HR, EG, TVS, SVS	One year	One year	Date of purchase or date of installation / training (if applicable), whichever occurs first, not to exceed 6 months from date of purchase
TITAN Industrial	WB, TV, HR, EG, EA, MR	One year	One year	
Material Handling	TWC, IC, TD, LD, GC, CR, CB, CC	One year	One year	
Blade Maintenance Equipment	BMS, BMT, BMST	One year	One year	Date of purchase
Options and Accessories	Various	One year*	One year*	
Moulders, Extractors	MP, MD	Two years	One year	
Kilns	KS, KD	One year	One year	
Slab Flatteners	MB	Two years	One year	
Pallet Equipment	PD, PC	One year	One year	
Log Splitters	FS	One year	One year	
Replacement Parts	Various	90 days	90 days	

* Warranty on Options will match the warranty on the primary equipment when purchased on same invoice.

Exclusions from 90 Day, Limited One Year and Two Year Warranty

Warrantor shall have no responsibility under this warranty for any wear components, including, but not limited to: belts, blade guides, blades, electric motor brushes, drum switches, filters, fuses, hoses, bearings (excluding cylindrical drive bearings), bushings, cable carriers, and spark plugs. All wear components are furnished "as is", without any warranty from Warrantor. This limited warranty does not cover any defects caused by misuse, negligence, alterations, damage due to overload, abnormal conditions, excessive operation, accident, or lack of performance of normal maintenance services.

Several components which are used in the manufacture of the equipment but not manufactured by Warrantor such as cant hooks, power plants, laser sights, batteries, tires, and trailer axles have warranties provided by the original equipment manufacturer (written copies available upon request). Warrantor does not separately warrant such items. Components or equipment manufactured by third parties are not covered by this warranty. Warrantor, however, will provide reasonable assistance to the Purchaser to make claims against any warranties applicable to such component parts as provided by such original equipment manufacturers. Components or equipment manufactured by third parties are not covered by this Warranty.

Five Year Limited Chassis Warranty

The limited five year chassis warranty described above, DOES NOT extend to (a) any damage stemming from accident, improper towing, overload, abuse, misuse, abnormal conditions, negligence, excessive operation, or lack of maintenance, (b) rust caused by exposure to corrosive atmospheric conditions, or (c) the sawmill head, carriage, axle, brakes, or any hydraulic or electrical components attached to the chassis.

Warrantor's Obligations as To Defects

In the event that the equipment fails to perform due to defective materials or workmanship attributable to Warrantor under normal use and service within the established warranty period, Purchaser's sole and exclusive remedy and Warrantor's sole liability shall be to replace or repair, in Warrantor's sole and subjective discretion, any defective part at Warrantor's principal place of business without cost to the Purchaser if such defect exists. The determination of whether a product is defective shall be made by Warrantor in Warrantor's sole and subjective discretion. The Purchaser must notify Warrantor prior to shipping any defective part. Warrantor, at its sole discretion, may cover expenses incurred in shipping the defective part to Warrantor for evaluation; provided, however, that Warrantor will not be responsible for labor, travel time, mileage, removal, installation or incidental or consequential damages. However, any part in excess of 140 pounds must be returned by the Purchaser, to the Warrantor's nearest authorized facility at the Purchaser's expense, if return is requested by Warrantor. Warrantor shall have a reasonable time within which to replace or repair the defective part. If Warrantor determines that the product is not defective under the terms of this warranty in Warrantor's sole and subjective discretion, then Purchaser shall be responsible for any expenses incurred by Warrantor in returning the equipment to the Purchaser.

Limitations and Disclaimers of Other Warranties

EXCEPT FOR THE EXPRESS WARRANTY PROVISIONS STATED ABOVE, WARRANTOR DISCLAIMS ALL WARRANTIES, EXPRESS AND/OR IMPLIED, INCLUDING WITHOUT LIMITATION, THE IMPLIED WARRANTIES OF MERCHANTABILITY, AND FITNESS FOR A PARTICULAR PURPOSE, NON-INFRINGEMENT AND TITLE. No representation or other affirmation of fact by representatives of Warrantor, whether verbal or in writing, including photographs, brochures, samples, models, or other sales aids, shall constitute a warranty or other basis for any legal action against Warrantor. There are no other representations, promises, agreements, covenants, warranties, guarantees, stipulations or conditions, express or implied, by Warrantor except as expressly set forth herein. THE ORIGINAL PURCHASER AND ANY INTENDED USER OR BENEFICIARY OF THIS EQUIPMENT, SHALL NOT BE ENTITLED TO RECOVER ANY INDIRECT, SPECIAL, PUNITIVE, EXEMPLARY, CONSEQUENTIAL, SPECIAL, OR INCIDENTAL DAMAGES OR LOSSES, INCLUDING BUT NOT LIMITED TO, DAMAGES OF LOST PRODUCTION, LOST REVENUE, LOST PRODUCT, LOST PROFITS, LOST BUSINESS, LOSS OF USE, LOSS OF GOODWILL, OR BUSINESS INTERRUPTION, FROM WARRANTOR FOR ANY REASON WHATSOEVER INCLUDING WITHOUT LIMITATION WARRANTY OR DEFECT IN THE PRODUCT REGARDLESS OF THE SOLE, JOINT AND/OR CONCURRENT NEGLIGENCE, BREACH OF CONTRACT, BREACH OF WARRANTY, STRICT LIABILITY IN TORT OR STATUTORY CLAIMS OR OTHER LEGAL FAULT OR RESPONSIBILITY OF EITHER WARRANTOR OR PURCHASER OR ITS EMPLOYEES OR AGENTS. Warrantor does not warrant that its equipment meets or complies with the requirements of any particular safety code or governmental requirements.

Defective items replaced under the terms of this warranty become the property of Warrantor.

Design Changes

Warrantor reserves the right to change the design of its products from time to time without notice and without obligation to make corresponding changes in or to its products previously manufactured.

Rights of Purchasers

The validity and effect of this limited warranty as well as its interpretation, operation and effect, shall be determined exclusively by the principles of law and equity of the State of Indiana, USA. This limited warranty gives Purchaser specific legal rights. Purchaser may also have other rights, which may vary from state to state. Some states may not allow limitations as to the duration of implied warranties or to the exclusion or limitation of incidental or consequential damages, so some of the limitations and exclusions detailed set forth above may not apply. In the event that any one or more of the provisions of this warranty shall be or become invalid, illegal or unenforceable in any respect, the validity, legality and enforceability of the remaining provisions of this warranty shall not be affected thereby.

Interpretations

This Warranty constitutes the entire warranty agreement between Warrantor and Purchaser and supersedes any prior understandings or agreements pertaining to the same subject matter. This warranty cannot be amended except in writing which refers to this warranty which is signed by both Warrantor and Purchaser.

SECTION 1 INTRODUCTION

1.1 About This Manual

This manual replaces any previous information received on your Wood-Mizer® equipment.

The information and instructions in this manual do not amend or extend the limited warranties for the equipment given at the time of purchase.

1.2 Getting Service

For contact information, sales, service, parts, and additional manuals, sign into your account on <https://woodmizer.com>, or call inside the USA: 1-800-553-0182 or from outside the USA: 317-271-1542

1.3 Specifications

Equipment specification are included in the Online Manuals, which are found at <https://apps.woodmizer.com/Manuals/Manuals.aspx?parent=0>.

1.4 Options and Accessories

Your Wood-Mizer product may have options that can be added to the machine or accessories available to purchase. Different power configurations are also available.

Option: Your specific product can have accessories installed at the factory, or installed in the field. For example, a sawmill might have a debarker or power-feed option.

Accessory: Your specific product may have accessories added to the machine that are not available to be installed at the factory. They may only be installed in the field. For example, a sawmill might have a bed extension or a Shingle/Lap Sider accessory.

Power Options: Your specific product power option is detailed based on the specific product number purchased.

This product has the following options available:

Document	Name	Type
903	Shingle Lap Sider	Accessory
1337	Lathe-Mizer	Accessory
1308	Lathe-Mizer Tenon Kit	Accessory
1624	RS2 Resaw	Accessory
2100	CookieMizer	Accessory
530	Bed Extension	Option
1791	Debarker	Option
2048	Debarker (076030)	Option
1524	Fine Adjust Outriggers	Option
1724	D17 Kohler	Engine
2209	D24 Yanmar	Engine
1726	G25 Kohler	Engine

SECTION 2 GENERAL SAFETY

2.1 Safety Symbols

The following symbols and signal words call your attention to instructions concerning your personal safety. Be sure to observe and follow these instructions.



DANGER! indicates an imminently hazardous situation which, if not avoided, will result in serious injury or death.



WARNING! suggests a potentially hazardous situation which, if not avoided, could result in serious injury or death.



CAUTION! refers to potentially hazardous situations which, if not avoided, may result in minor or moderate injury or damage to equipment.

NOTICE indicates vital information.

2.2 Safety Instructions

OWNER/OPERATOR'S RESPONSIBILITY

The procedures listed in this manual may not include all ANSI, OSHA, or locally required safety procedures. **It is the owner/operator's responsibility and not Wood-Mizer LLC to ensure all operators are properly trained and informed of all safety protocols.** Owner/Operators are responsible for following all safety procedures when operating and performing maintenance to the equipment.

Observe ALL Safety Instructions

NOTICE Read the entire Operator's Manual before operating this equipment.

Note all safety warnings throughout this manual and those posted on the machine.

Be able to access this manual at all times while operating this equipment.

Read additional manufacturer's manuals and observe their applicable safety instructions.

Only persons who have read and understood the entire operator's manual should operate this equipment.

This equipment is not intended for use by or around children.

It is the owner/operator's responsibility to comply with all applicable federal, state, and local laws, rules, and regulations regarding the ownership, operation, and transporting your equipment.

Operators should become thoroughly familiar with and comply with these applicable laws for operating and transporting equipment.



WARNING! Clean sawdust from all guards, vents, control boxes, or any area where sawdust may gather **after every shift**. Failure to do so may result in fire, causing death or serious injury.

WEAR SAFETY CLOTHING



WARNING! Secure all loose clothing and jewelry before operating the mill.

Always wear eye, ear, and foot protection when operating or servicing the mill.

Wear hand protection while servicing the mill blades.

Wear respiratory protection when sawing woods that require it. (It is up to the sawyer to know which woods require respiratory protection.)

HANDLE FUEL/LUBRICANTS SAFELY



DANGER! Due to the flammable nature of fuel and oil, never smoke, weld, grind or allow sparks near your engine or storage tanks, especially during times of fueling.

Do not allow fuel to spill on a hot engine during fueling operations or otherwise.



WARNING! Store gasoline away from sawdust and other flammable materials.

Do not use flammable fuels or liquids such as diesel fuel. Use **ONLY** water and Wood-Mizer Lube Additive with the water lube accessory.

MILL SETUP



WARNING! Set up the mill on solid, level ground with less than 10 degrees of slope.

Keep all persons out of the area between the frame rails while loading and unloading the sawmill.

Chock the trailer wheels to prevent movement before unhitching it from the towing vehicle.

Put front outrigger down before moving saw head from the rest position.

Ensure the trailer provides the additional necessary support to the sawmill frame when operating a sawmill with adjustable outriggers.

If setting the sawmill up on concrete or other hard surface, replace the adjustable outrigger legs with stationary legs. Outriggers are not meant for use on concrete.

Securely fasten the feet of a stationary sawmill to the floor before operating the sawmill.

BLADE HANDLING

 **DANGER!** Coiled blades are under spring tension. Know proper blade handling before unpacking your blade. Failure to follow this will result in serious injury.

Wear gloves and eye protection when handling bandsaw blades.

Keep all other persons away from area when coiling, carrying, or changing a blade; changing blades is safest when done by one person.

Watch the video on sawmill blades before removing the blade from the box. Go to: <https://www.youtube.com/watch?v=43TWwSgSOaQ>



HOW TO COIL, UNCOIL,
AND INVERT A BLADE

GENERAL TRAILER SAFETY

 **WARNING!** Ensure your hitch has adequate safety chain hookups (not eyebolts).

Hook safety chains to bumper of vehicle so that each chain would pull the trailer equally in the event the hitch became disengaged.

Ensure the hitch and safety chains are secure before towing the sawmill.

Ensure all light connections have been made and are working properly before towing the sawmill.

Check trailer tires for proper inflation before towing sawmill.

The trailer option is designed for the express purpose of towing the sawmill it is supplied with. **Do not make modifications** that affect the weight and/or stability of the towing unit.

 **CAUTION!** Move the optional hydraulic clamp and turner to provide maximum ground clearance before towing. Failure to follow this could result in damage to the sawmill.

ELECTRIC BRAKE TRAILER SAFETY

 **WARNING!** Ensure the electric brake wire is secured as close to the trailer axle as possible to prevent wire disconnection during towing.

Ensure electric brake battery is charged and is working properly before towing the sawmill.

 **CAUTION!** Do not use the electric brake system as a “parking brake” while the sawmill is not being

towed. Extended use of the electric brakes while the sawmill is stationary will drain the brake battery.

CHECK SAWMILL BEFORE OPERATION

 **WARNING!** Ensure all guards and covers are in place and secured before operating or towing the sawmill.

Use the safety retainer pin and cable to fasten blade housing covers.

Check your blades: Do not use blades with stress cracks.

Ensure the power feed switch is in the neutral position before turning the key switch to the “on” or “accessory” position to prevent accidental carriage movement.

Use both hands to operate the blade tensioner handle. Be sure the handle lock engages (flips down) after tensioning the blade.

KEEP PERSONS AWAY

 **DANGER!** Keep all persons out of the path of moving equipment and logs when operating sawmill or loading and turning logs.

Ensure the blade is disengaged and all persons are out of the path of the blade before starting the engine or motor.

KEEP HANDS AWAY

 **DANGER!** Keep hands away from moving blades.

Remove power before clearing debris or any other maintenance activity.

Disengage the blade and shut off the sawmill engine before changing the blade.

 **WARNING!** Avoid contact with any hot parts (engines/motors).

Allow the system to cool sufficiently before beginning any service function, including debris removal.

Avoid contact with sharp edges of the cutting blades.

Stay a safe distance from rotating members (shafts, pulleys, fans, etc.) and ensure loose clothing or long hair does not engage rotating members

Do not spin the blade wheels by hand. Spinning the blade wheels by hand may result in serious injury.

Disengage the clutch/brake mechanism whenever the sawmill is not cutting.

Do not adjust the engine drive belt with the engine running.

Keep hands, feet, etc., clear of exiting sawdust chute when operating sawmill.

Do not attempt to charge a frozen battery.

UP/DOWN SYSTEM SAFETY

 **WARNING!** Secure the saw head with a chain with a minimum of 1900 lbs. working load capacity before adjusting the up/down system.

Release pressure from the up/down assist prior to performing any service to the assembly. Parts are under tension and may fly apart.

Do not disassemble the pressurized cylinders. Parts are under pressure and may fly apart or damage the cylinder.

KEEP SAFETY LABELS IN GOOD CONDITION

NOTICE Ensure that all safety decals are clean and readable. Replace all damaged safety decals to prevent personal injury or damage to the equipment. Contact your local distributor, or call your Customer Service Representative to order more decals.

NOTICE If replacing a component that has a safety decal affixed to it, ensure the new component also has the safety decal affixed.

KEEP MILL AND AREA AROUND MILL CLEAN

WARNING! Maintain a clean and clear path for all necessary movement around the mill and material stacking areas.

Do not allow children in the area of the mill. Failure to follow this may result in death or serious injury.

GAS OR DIESEL ENGINE OPERATION

 **DANGER!** Operate your engine/machine only in well ventilated areas.

Do not operate an engine with a fuel or oil leak.

 **WARNING!** Do not operate engine without proper and operational spark arrester/muffler.

DISPOSE OF WOOD BY-PRODUCTS PROPERLY

NOTICE Properly dispose of all wood by-products, including sawdust, chips, and other debris, including operation waste such as oil, filters, etc.

WORKING WITH BATTERIES

 **DANGER!** Batteries expel explosive gases; keep sparks, flames, burning cigarettes, or other ignition sources away at all times. Failure to follow this will result in serious injury or death.

 **WARNING!** Always wear safety goggles and a face shield when working near batteries.

Wash hands after handling batteries to remove possible lead, acid, or other contaminants.

Charge the battery in a well ventilated area.

EMERGENCY TREATMENT FOR CONTACT WITH BATTERY COMPONENTS (LEAD/SULFURIC ACID) per SDS (Safety Data Sheet):

EYE CONTACT	Sulfuric Acid and Lead: Flush eyes immediately with large amounts of water for at least 15 minutes while lifting lids. Seek immediate medical attention.
SKIN CONTACT	Sulfuric Acid: Flush affected area(s) with large amounts of water using deluge emergency shower, if available, shower for at least 15 minutes. Remove contaminated clothing, including shoes. If symptoms persist, seek medical attention. Wash contaminated clothing before reuse. Discard contaminated shoes. Lead: Wash immediately with soap and water.
INGESTION	Sulfuric Acid: Administer large amounts of water. Do NOT induce vomiting or aspiration into the lungs may occur and can cause permanent injury or death; consult physician.
INHALATION	Sulfuric Acid: Remove to fresh air immediately. If not breathing, give artificial respiration. If breathing is difficult, give oxygen. Consult a physician. Lead: Remove from exposure, gargle, wash nose and lips; consult physician.

 **CAUTION!** Do not overcharge the battery. Overcharging may reduce the overall service life of the battery.

Ensure the battery is fully charged before transporting the sawmill. If the battery is not fully charged, excessive vibration could reduce the overall service life of the battery.

NOTICE When working with batteries, use extreme care to avoid spilling or splashing electrolyte (dilute sulfuric acid) as it can destroy clothing and burn the skin.

2.3 Electrical Lockout Procedures

RULES FOR USING LOCKOUT PROCEDURE

The equipment shall be locked out to protect against accidental or inadvertent operation when such operation could cause injury to personnel. Do not attempt to operate any switch or valve bearing a lock.

LOCKOUT PROCEDURES MUST BE USED DURING, BUT NOT LIMITED TO:

- Changing or adjusting blades
- Unjamming operations
- Cleaning
- Mechanical repair
- Electrical maintenance
- Retrieval of tools/parts from work area
- Activities where guards or electrical panel guard is open or removed

MAINTENANCE HAZARDS INCLUDE, BUT NOT LIMITED TO:

- Blade contact
- Pinch points
- Kickbacks
- Missiles (thrown blades/wood chips)
- Electrical

FAILURE TO LOCKOUT MAY RESULT IN, BUT NOT LIMITED TO:

- Cut
- Crush
- Blindness
- Puncture
- Electrocution
- Serious injury and death
- Amputation
- Burn
- Shock

TO CONTROL MAINTENANCE DANGERS:

- Lockout procedures must be followed (see **OSHA regulation 1910.147**).
- Never rely on machine stop control for maintenance safety (emergency stops, on/off buttons, interlocks).
- Do not reach into moving blades or feed systems. Allow all coasting parts to come to a complete stop.
- Electrical power supply and air supply must both be locked out.
- Where established lockout procedures cannot be used (electrical troubleshooting or mechanical dynamic troubleshooting), alternative effective protective techniques shall be employed which may require special skills and planning.
- Always follow safe operations practices in the workplace.

EQUIPMENT LOCKOUT PROCEDURE

Lockout procedures per OSHA regulation 1910.147, appendix A:

GENERAL

The following simple lockout procedure is provided to assist owner/operators in developing their procedures so they meet the requirements of **OSHA regulation 1910.147**. When the energy isolating devices are not lockable, tagout may be used, provided the owner/operator complies with the provisions of the standard which require additional training and more rigorous periodic inspections. When tagout is used and the energy isolating devices are lockable, the owner/operator must provide full operator protection (see OSHA regulation 1910.147, paragraph (c)(3)) and additional training and more rigorous periodic inspections are required. For more complex systems, more comprehensive procedures may need to be developed, documented, and utilized.

PURPOSE

This procedure establishes the minimum requirements for the lockout of energy isolating devices whenever maintenance or servicing is done on machines or equipment. It shall be used to ensure that the machine or equipment is stopped, isolated from all potentially hazardous energy sources and locked out before personnel perform any servicing or maintenance where the unexpected energization or start-up of the machine or equipment or release of stored energy could cause injury.

COMPLIANCE WITH THIS PROGRAM

All personnel are required to comply with the restrictions and limitations imposed upon them during the use of lockout. The authorized personnel are required to perform the lockout in accordance with this procedure. All operators, upon observing a machine or piece of equipment which is locked out to perform servicing or maintenance shall not attempt to start, energize, or use that machine or equipment.

SEQUENCE OF LOCKOUT

1. Notify all affected personnel that servicing or maintenance is required on a machine or equipment and that the machine or equipment must be shut down and locked out to perform the servicing or maintenance.
2. The authorized employee shall refer to the company procedure to identify the type and magnitude of the energy that the machine or equipment utilizes, shall understand the hazards of the energy, and shall know the methods to control the energy.
3. If the machine or equipment is operating, shut it down by the normal stopping procedure (depress the stop button, open switch, close valve, etc.).
4. De-activate the energy isolating device(s) so that the machine or equipment is isolated from the energy source(s).
5. Lock out the energy isolating device(s) with assigned individual lock(s).
6. Stored or residual energy (such as that in capacitors, springs, elevated machine members, rotating flywheels, hydraulic systems, and air, gas, steam, or water pressure, etc.) must be dissipated or restrained by methods such as grounding, repositioning, blocking, bleeding down, etc.
7. Ensure that the equipment is disconnected from the energy source(s) by first checking that no personnel are exposed, then verify the isolation of the equipment by operating the push button or other normal operating control(s) or by testing to make certain the equipment will not operate.



CAUTION! Return operating control(s) to neutral or "off" position after verifying the isolation of the equipment.

8. The machine or equipment is now locked out.

RESTORING EQUIPMENT TO SERVICE

When the servicing or maintenance is completed and the machine or equipment is ready to return to normal operating condition, the following steps shall be taken.

1. Check the machine or equipment and the immediate area around the machine to ensure that nonessential items have been removed and that the machine or equipment components are operationally intact.
2. Check the work area to ensure that all personnel have been safely positioned or removed from the area.
3. Verify that the controls are in neutral.

4. Remove the lockout devices and re-energize the machine or equipment.

NOTE: The removal of some forms of blocking may require re-energization of the machine before safe removal.

5. Notify affected personnel that the servicing or maintenance is completed and the machine or equipment is ready for use.

PROCEDURE INVOLVING MORE THAN ONE PERSON

In the preceding steps, if more than one individual is required to lock out the equipment, **each shall place his own personal lock on the energy isolating devices.**

SECTION 3 SAWMILL SETUP

3.1 Stationary Sawmill Setup

Prepare the site:

- Area must be firm and level.
- The cement pad should be rated to support 6350 lbs./sq.ft.
- Use 5/8" diameter anchor bolts to secure feet.
- Allow maneuvering room for operators, sawdust removal, log loading, and board removal.
- Check the specification online for foot anchor placement.

NOTE: The unit must be level before securing. It **IS POSSIBLE** to twist the mill frame by jacking one foot higher than the others.



WARNING! Securely fasten the feet of a stationary sawmill to the floor before operating the sawmill.

1. Unhook the carriage safety chain, located at the bottom of the vertical mast.
2. Release the fender straps and lift up to remove the fenders. **See Fig. 3-1.**
3. Stow until needed for transport.
4. Start the engine to enable the battery-operated accessories ([See Section 3.6](#)).

NOTE: Operating the controls without the engine running will result in power drainage from the battery.

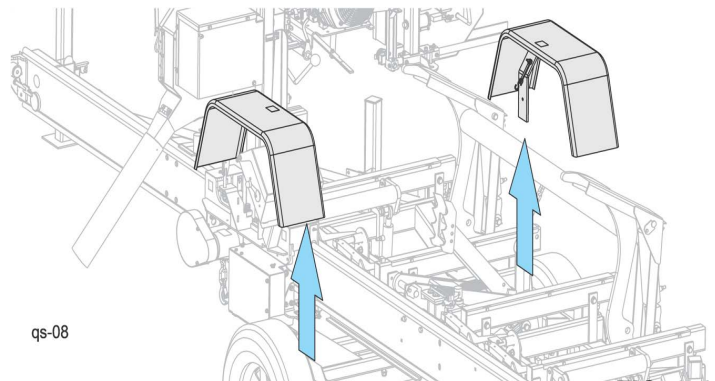

FIG. 3-1

5. Use the up/down switch on the control panel to raise the cutting head from the carriage rest pin. **See Fig. 3-2.**
6. Remove the locking pin and swing the rest pin down below bed level.

NOTE: Operating the controls without the engine running will result in power drainage from the battery.

7. Use the carriage forward/reverse switch (left side of control box) to move the cutting head toward the front (hitch end) of the mill. **See Fig. 3-3.**
8. Raise the side supports to prevent a log from falling off the side of the mill when loaded.

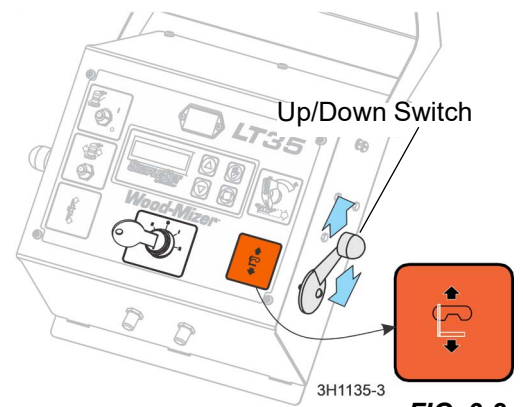

FIG. 3-2

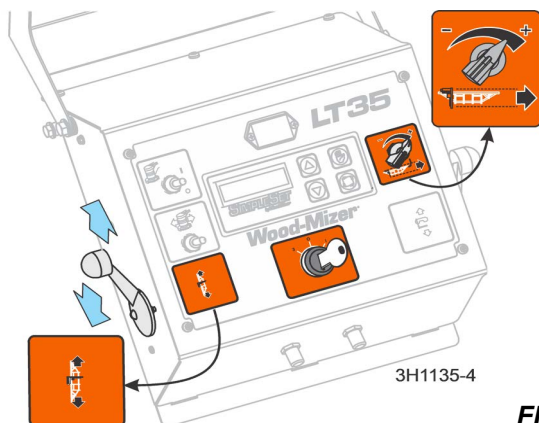

FIG. 3-3

3.2 Portable Sawmill Setup

WARNING! Do not set up the mill on ground with more than a 10 degree incline.

If setup on an incline is necessary, put blocks under one side of the mill or dig out areas for outrigger legs to keep mill level. Setting up the mill on an incline could cause it to tip over, resulting in serious personal injury.

Chock the trailer wheels to prevent movement before unhitching it from the towing vehicle.

Ensure the trailer is supporting the sawmill frame when operating a sawmill with adjustable outriggers. The adjustable outriggers are intended to support the saw frame with assistance from the trailer.

The adjustable outriggers supplied with portable sawmills are not intended for setup on concrete or other hard surfaces. Long-term use of the adjustable outriggers on hard surfaces may cause the outriggers to fail, causing the sawmill to drop.

If setting the sawmill up on concrete or other hard surface, replace the adjustable outrigger legs with stationary legs.

1. Unhitch the mill from the vehicle.
2. Lower and set the front three outriggers. **See Fig. 3-4.**
 - 1). Use the provided jack handle to lift the weight from the locking pin.
 - 2). Rotate the locking pin counterclockwise so that the inner roll pin is free from the outrigger channel notch, then pull the locking pin out to release the outrigger.
 - 3). Lower the outrigger as necessary.
 - 4). Push the locking pin back in and turn clockwise until the inner roll pin is behind the outrigger channel notch to “lock” the outrigger in place.

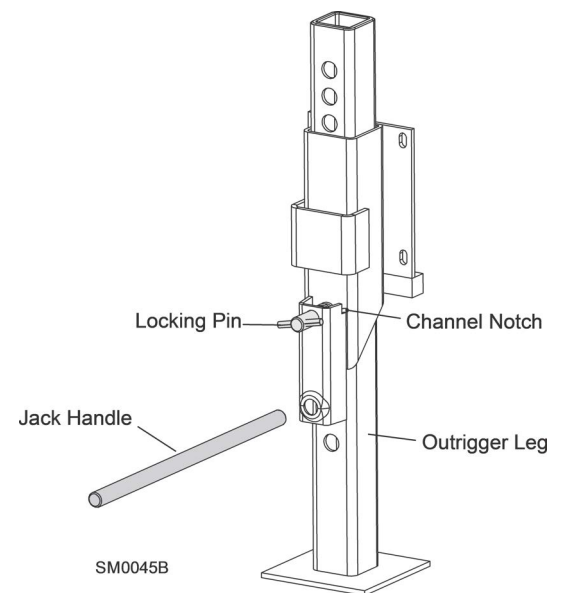

FIG. 3-4

WARNING! Put front outrigger down before moving cutting head from the rest position.

If sawmill is equipped with optional Fine Adjust Outriggers (FAO), see the option manual for outrigger operation.

3. Unhook the carriage safety chain, located at the bottom of the vertical mast.
4. Start the engine to enable the battery-operated accessories ([See Section 3.6](#)).

NOTE: Operating the controls without the engine running will result in power drainage from the battery.

5. Use the up/down switch on the control panel to raise the cutting head from the carriage rest pin. **See Fig. 3-2.**
6. Remove the locking pin and swing the rest pin down below bed level.
7. Remove the fenders by lifting them out of the slots. **See Fig. 3-1.**

CAUTION! To prevent fender damage, remove fenders before operating sawmill or loading logs.

8. Use the feed control switch (left side of control box) to move the cutting head toward the front end of the mill. **See Fig. 3-3.**
9. Lower and set the remaining rear outriggers. Level the sawmill by adjusting the outriggers to raise or lower each end of the sawmill. Adjust all outriggers evenly to avoid twisting the mill frame by jacking one outrigger higher than the others.

For FAO(s), fine tune the outrigger base height as necessary. Move the cutting head to the opposite end of the mill from the outrigger. Raise the entire outrigger (to remove the sawmill weight from it) and adjust the outrigger base as necessary. Lower the entire outrigger and use the locking pin to secure in position.

CAUTION! Do not adjust the FAO outrigger base height while there is weight on the FAO. Damage to the FAO may result.

10. Raise the two side supports to prevent the log from falling off the side of the mill when loaded. See Fig. 3-5.

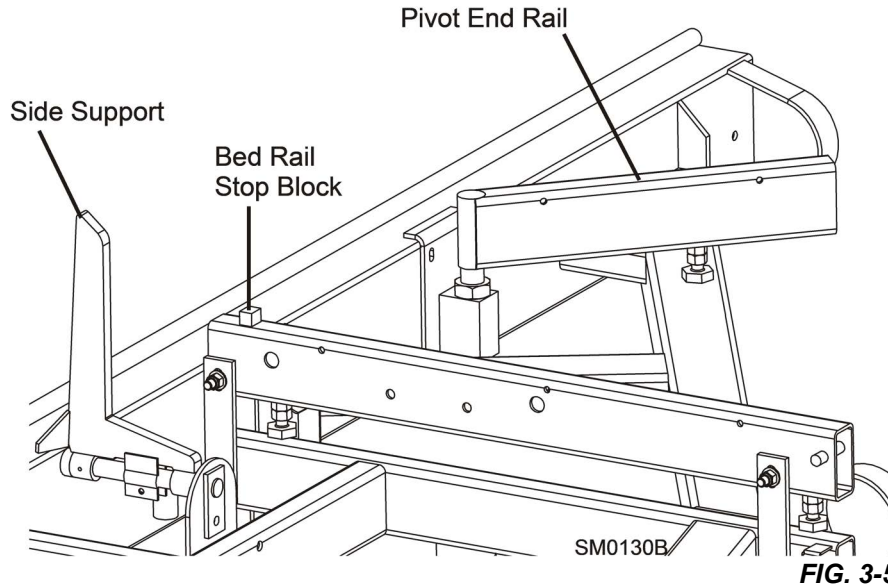

FIG. 3-5

3.3 Installing the Blade

! **DANGER! COILED BLADES ARE UNDER SPRING TENSION. KNOW PROPER BLADE HANDLING BEFORE UNPACKING YOUR BLADE. FAILURE TO FOLLOW THIS WILL RESULT IN SERIOUS INJURY.**

Always disengage the blade and shut off the sawmill engine before changing the blade.

! **WARNING!** Keep all other persons away from area when coiling, carrying, or changing a blade; changing blades is safest when done by one person.

Wear gloves and eye protection when handling bandsaw blades.

Watch the video on sawmill blades before removing the blade from the box.

Go to: <https://www.youtube.com/watch?v=43TWwSgSOaQ>



HOW TO COIL, UNCOIL,
AND INVERT A BLADE

1. Open the two blade housing covers that cover the blade wheels.
2. Turn the blade tension handle to release the blade tension until the wheel is pulled in and the blade is lying loose in the blade housing.
3. Lift the blade out of the blade housing.
4. Ensure the teeth are pointing the correct direction toward sawdust chute. See Fig. 3-6.

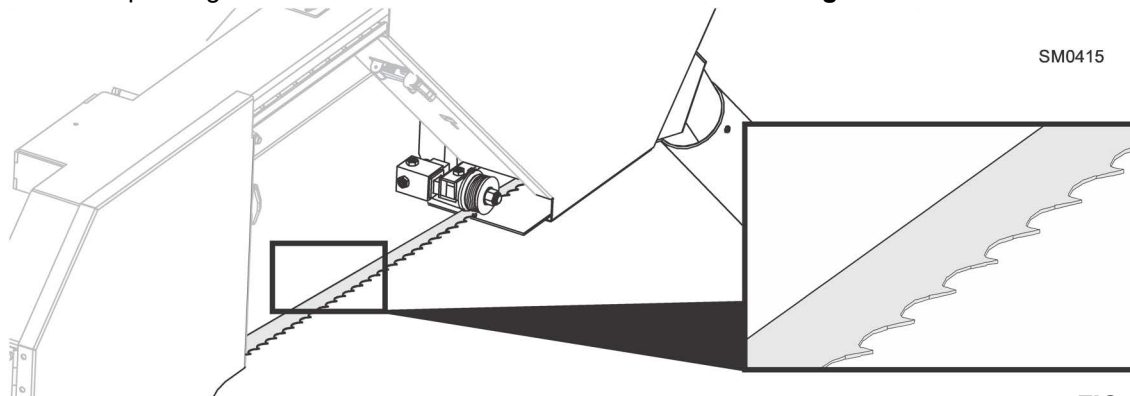

FIG. 3-6

5. Install the blade so it is lying around the wheels.

6. Position 1 1/4" wide blades on the wheels so the gullet is 1/8" (3.0 mm) out from the edge of the wheel.
7. Close the blade housing covers.
8. Use the tension handle to tension the blade correctly.

3.4 Tensioning The Blade

The blade tensioner is factory-set so proper blade tension is achieved when the rubber spring is compressed 3/16" (4.8 mm). An indicator bolt is provided to indicate when the rubber spring has been compressed properly. To tension the blade, turn the blade tension handle up until it locks in place.

WARNING! Use both hands to operate the blade tensioner handle.

1. Check the back side of the rubber spring washer is aligned with the indicator bolt head. **See Fig. 3-7.**

If not, release the blade tension and turn the tensioner shaft counterclockwise to compress the rubber spring more; clockwise to compress the rubber spring less.

2. Use the scalloped disk to turn the tensioner shaft.
3. Tension the blade and recheck the alignment of the rubber spring washer with the indicator bolt head.
4. Check the blade tension occasionally when adjusting the cant control or while cutting.

As the blade and belts heat up and stretch, the blade tension will change. Adjust the tensioner shaft as necessary to maintain proper blade tension.

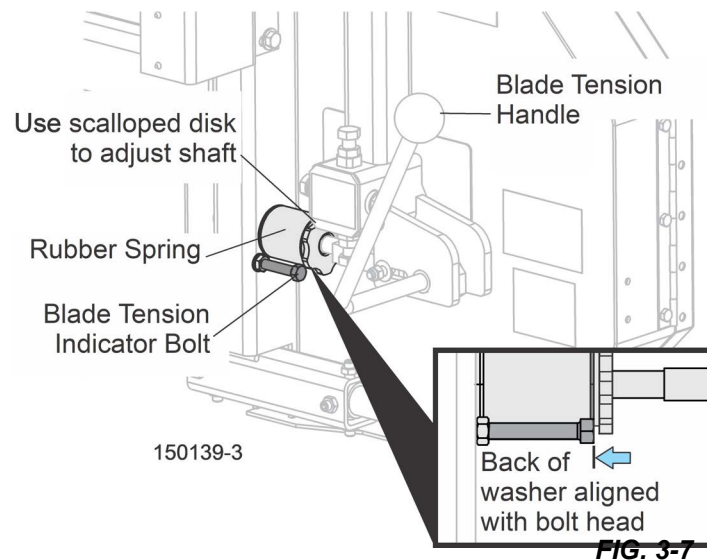

3.5 Tracking The Blade

1. Ensure the blade housing covers are closed and all persons are clear of the open side of the saw head.
2. Start the engine.
3. Engage the blade, rotating the blade until the blade positions itself on the wheels.

WARNING! Do not spin the blade wheels by hand. Spinning the blade wheels by hand may result in serious injury.

4. Disengage the blade.
5. Turn off the engine, remove the key and check the position of the blade on the blade wheels.
6. Position 1 1/4" wide blades so the gullet is 1/8" (3.0 mm) out from the edge of the blade wheel ($\pm 1/32$ [0.75 mm]). **See Fig. 3-8.**

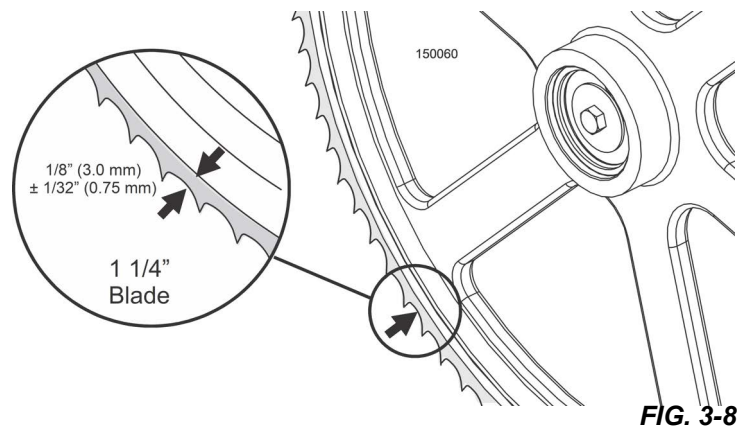

3 Sawmill Setup

Starting The Engine

7. Use the cant control to adjust where the blade travels on the blade wheels. **See Fig. 3-9.**

Adjust the wheel by turning the cant control until the gullet of the blade is the correct distance from the front edge of the wheel.

8. Adjust the blade tension if necessary to compensate for any changes that occurred while adjusting the cant control.
9. Close the blade housing covers.

! **DANGER!** Ensure all guards, covers, blade housings, and pulley covers are in place and secured before operating or towing the sawmill.

NOTICE After aligning the blade on the wheels, double-check the blade guide spacing and location. ([See Section SECTION 7](#) for more information.)

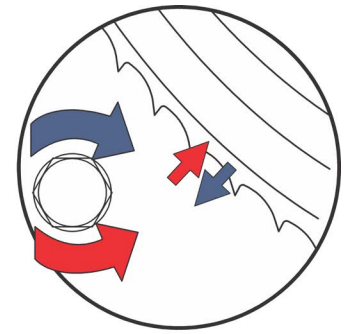
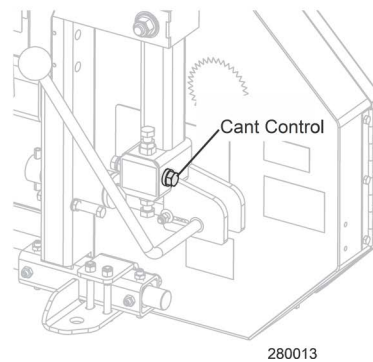

FIG. 3-9

3.6 Starting The Engine

See the appropriate manual supplied with your specific engine/motor configuration for starting and operating instructions.

! **DANGER!** Ensure all guards, covers, blade housings, and pulley covers are in place and secured before operating or towing the sawmill.

Always ensure the blade is disengaged and all persons are out of the path of the blade before starting.

! **WARNING!** Always wear eye, ear, respiration, and foot protection when operating the sawmill.

Ensure the power feed switch (if equipped) is in the neutral position before turning the key switch to the on (#1) or accessory (#3) position. This prevents accidental carriage movement which may cause serious injury or death.

SECTION 4 SAWMILL OPERATION

4.1 Hydraulic Control Operation

The hydraulic control levers become operational when the contacts at the bottom of the carriage touch the power strip on the frame tube. The hydraulic control levers will only work when the cutting head is close enough to the front end of the mill to touch the power strip.

Hydraulic units have six control levers to load, clamp, turn, and level logs. See Fig. 4-1.

DANGER! Keep all persons out of the path of moving equipment and logs when operating sawmill or loading and turning logs.

CAUTION! Always make sure the engine is running before operating the hydraulic controls. Operating the controls without the engine running will result in power drainage from the battery. Holding the hydraulic switches halfway up or down also will cause excessive drainage from the battery.

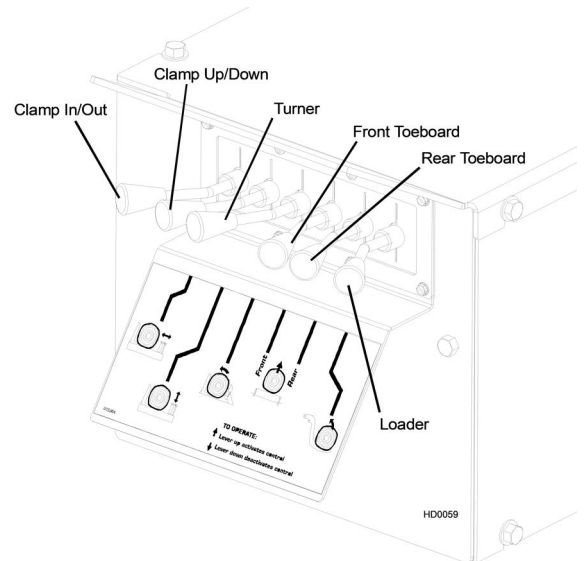
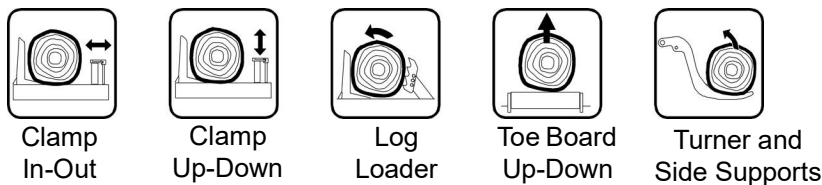

FIG. 4-1

1. Move the clamp out and down so it will not get in the way of logs being loaded onto the bed.
 - 1). Lower the clamp in/out lever to move the clamp out toward the loading side of the sawmill.
 - 2). Lower the clamp up/down lever to lower the clamp below bed level.

2. Raise the log loader lever to extend the legs of the log loader out as far as they will go.

The chain securing the log loading arm to the log turner arm will be tight.

3. Raise the log turner lever to raise the turner arm until there is slack in the chain.
4. Unchain the loading arm from the turner arm.
5. Lower the turner lever to completely lower the turner arm.

NOTICE After the turner arm is all the way down, the side support braces will begin to lower. Release the turner lever after the turner arm is lowered, but before the side supports begin to lower. This stops the log being loaded from damaging the turner and/or falling off the side of the sawmill.

When raising the turner lever, the side supports rise first. After reaching a fully vertical position, the turner arm will engage and start to rise.

6. Manually lower the log loader so it rests on the ground.

CAUTION! Do not drop the loader onto the ground or perform any action which might break the velocity fuse valves on the loader cylinders. These valves control hydraulic flow and are necessary to prevent the loading arm from collapsing during use.

7. Lower the loader lever fully down.

CAUTION! Load logs one at a time.

8. Lower the front and rear toe boards below bed level.

For a tapered log, use the toe boards to level the heart of the log to the path of the blade. After the first cut, the log may be turned. Lower the toe boards until they fall below the level of the bed.

4.2 Loading, Turning And Clamping Logs

Loading Logs

1. Start the engine and move the saw carriage to the front end of the frame.

 **CAUTION!** Before loading a log, ensure the cutting head is moved far enough forward so the log does not hit it. Ensure the log clamp are adjusted out of the path of the log before loading a log onto the bed. Failure to do so may result in machine damage.

2. Raise the side supports on the sawmill bed to prevent the log from falling off the side of the bed.
3. Roll the log onto the loader so that it is approximately centered with the sawmill bed.
4. Raise the loading arm until the log rolls onto the log bed.
5. Raise the log clamp and clamp the log in place.
6. Lower the loading arm halfway, leaving it partially up to prevent the log from accidentally rolling off while turning it.

NOTE: Logs also may be loaded onto the mill with a tractor or other loading equipment.

Turning Logs

1. Engage the log turner arm until it touches the log and starts to turn it.
2. Spin the log against the side supports until it is turned the way you want it for the first cut.
3. To turn the log more, clamp the log against the side supports and lower the turner arm below the log.
4. Raise the turner arm to get a new bite on the log.
5. Disengage the clamp and continue turning the log.
6. Repeat steps 3 through 5 until the log is turned as desired.

To Turn Logs (Optional Procedure)

If you are turning a small cant on a mill, use the clamp to turn the cant.

1. Lower the clamp below bed level.
2. Move the clamp in, beneath the edge of the cant.
3. Raise the clamp and flip the cant.

Clamping the log

1. Clamp the log against the side supports.
2. Lower the turner lever until the turner arm falls below the bed and the side supports begin to lower.
3. Back the clamp off slightly to allow the side supports to lower until they are positioned below the level of your cuts.
4. Position the clamp below the level of your cuts and retighten the clamp.
5. Repeat these steps as the cuts become lower.

To Level A Tapered Log

1. Use the toe boards levers to raise either end of a tapered log, if desired.
2. Raise the front or rear toe board until the heart of the log is parallel to the log bed.

4.3 Up/Down Operation

1. Install a blade, if needed, and check for correct blade tension. ([See Section 3.3](#)).
2. Set the cutting head to the desired height. (The blade height scale shows the height of the blade above the bed rails.)

The up/down switch is located on the right side of the control panel. **See Fig. 4-2.** Use the switch to raise or lower the cutting head. Hold the switch in position until the cutting head reaches the desired height, then release.

NOTE: The up/down switch is designed to return to the neutral or "off" position when released. If the switch remains engaged, manually move the switch to the neutral or "off" position. Repair the up/down switch

NOTICE Do not try to force the carriage above the 27" (68 cm) mark or below the 1" (2.54 cm) mark. Damage to the up/down system may result.

Always ensure the up/down switch moves to the neutral or "off" position when released to ensure that the saw head stops moving. Failure to do so may result in machine damage.

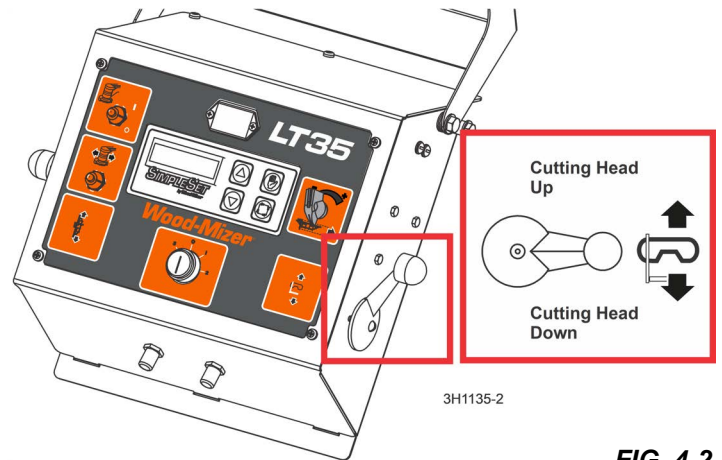

FIG. 4-2

4.4 Simple Set Operation

Initial Setup

Turn the sawmill control key switch to the ON (#1) position. Simple Set will start up in manual mode. As the control powers up, the software revision is displayed. **See Fig. 4-3.** This information can be helpful should you require service.

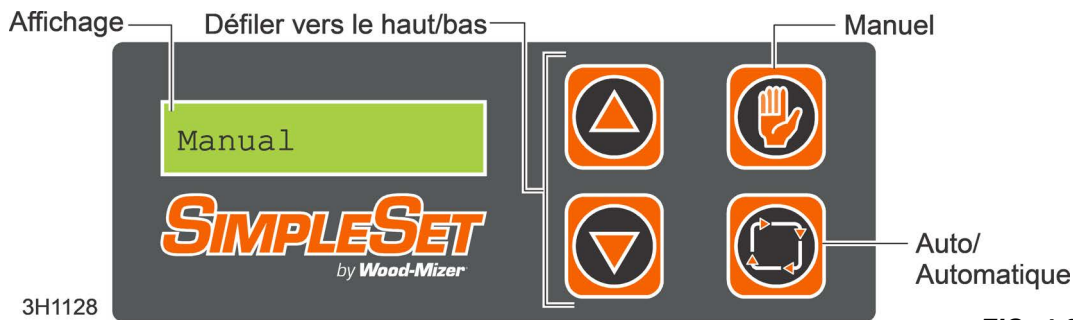

FIG. 4-3

In manual mode, press the Up arrow to enter the setup menus.

Set Speed: Available values are 1 - 5. The default value is 5. Lowering the Set Speed will assist in achieving the desired blade height setting in situations where the up/down chain is too loose.

Use the Up and Down buttons to scroll to the desired Set Speed setting.

Press the Auto button to scroll to the Units menu or the Manual button to exit.

Units: Simple Set can display units in inches (default) or millimeters.

Push the Up or Down buttons to scroll to the desired unit setting.

Press the Auto button to scroll to the Language menu or the Manual button to exit.

Language: To date, the only available language is English.

Press the Auto button to scroll back to the Set Speed menu or the Manual button to exit.

Operation

Turn the sawmill control key switch to the ON (#1) position. Simple Set will start up in manual mode

 **Manual:** Manual mode operates the sawmill up/down system as normal with the sawmill control up/down switch. The display will show a 'D' when the up/down switch is pushed down and a 'U' when pushed up.

 **Auto:** In auto mode, the saw head moves down the increment displayed when the sawmill control up/down switch is activated in the down position. The saw head will move up as normal when the up/down switch is activated in the up position.

- Two sets of values can be stored in the control. Push the Auto button to toggle between Set1 and Set2.
- Use the Up and Down buttons to adjust the value in 1/16" (or 1mm) increments in Set1 or Set2.
- Bump the up/down switch down to move the blade to the next increment. Holding the switch up or down will bypass Simple Set and move the saw head until the up/down switch is released.
- If the saw head is raised before the next cut, bumping the up/down switch down will return the saw head to the original position **plus the increment value**.
- Push the Manual button to exit auto mode.

Turn the sawmill control key switch to the OFF (#0) position to power off Simple Set.

4.5 Blade Guide Arm Operation

Adjust the outer blade guide to clear the widest section of the log by less than 1" (25.4 mm). See Fig. 4-4.

4.6 Feed Operation

The Forward/Reverse and Forward Feed Rate switches are used to control the carriage movement. See Fig. 4-5.

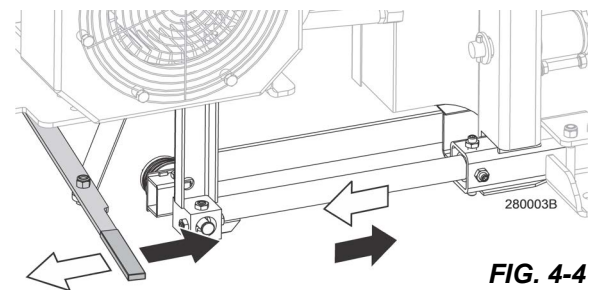

FIG. 4-4

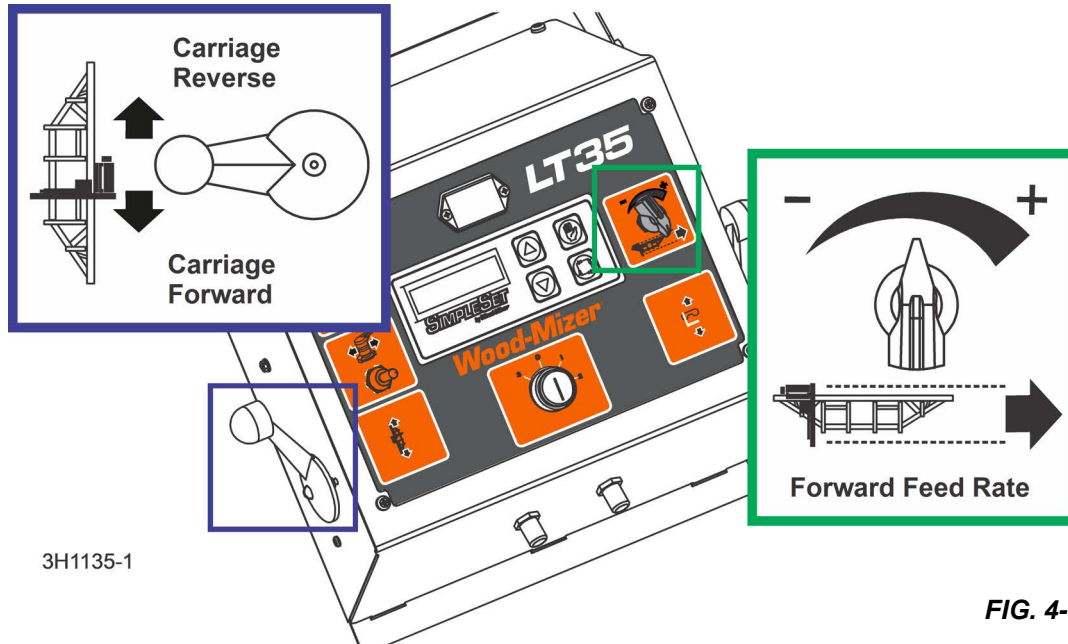



FIG. 4-5

The middle position of the Forward/Reverse switch (as shown in FIG. 4-5) is the neutral position. The switch is designed to return to the neutral or "off" position when released from operating in the reverse position.

NOTE: If the switch remains engaged, manually move the switch to the neutral or "off" position. Repair the switch ([See Section 5.6](#)).

 **WARNING!** Ensure the power feed switch is in the neutral position before turning the key switch to the on (#1) or accessory (#3) position. This prevents accidental carriage movement which may cause serious injury or death.

USING THE POWER FEED

1. Push the forward/reverse switch forward (downward) and turn the feed rate switch clockwise.

HINT: To get a straight cut in the first part of the board, feed the blade into the log at a slow speed to keep the blade from flexing and dipping up or down. Turn the carriage feed rate switch to a slow speed until the entire width of the blade enters the cut. Increase the feed rate as desired. Maximum feed rate varies with width and hardness of the wood. Feeding too fast may result in engine and blade wear, and produces a wavy cut.

2. Stop the carriage at the end of the cut by turning the carriage feed rate switch counterclockwise.
3. Move the clutch lever up to stop the blade and drop the engine to idle.
4. Remove the board from the top of the log.



WARNING! Always disengage the blade before returning the carriage for the next cut.

Ensure the blade stops when returning the carriage. This will not only prevent the blade damage, but also will increase the life of the blade.

5. Raise the carriage so that the blade clears the log when returned.
6. Return the carriage.

The power feed motor will bypass the carriage feed rate switch and the carriage will automatically return at the fastest speed available.

HINT: Try to stop the blade while the heel of the blade is still on the log. Then bring the carriage back without adjusting the blade up. This lets you keep the blade at the current height setting so you can make the next blade height adjustment more quickly.



DANGER! Stay clear of the area between the trailer axle and saw carriage.

4.7 Cutting The Log

1. Clamp the log firmly, start the engine if not already started, and move the saw head to position the blade close to the end of the log.
2. Set the blade to the desired height

NOTE: Ensure that the blade will clear all side supports and the clamp. Adjust the outer blade guide to clear the widest section of the log

3. Engage the clutch to start the blade spinning.
4. Start the water lube (if necessary) to prevent sap buildup on the blade. [See Section 4.11.](#)
5. Feed the blade into the log slowly. But once the blade completely enters the log, increase the feed rate as desired.

NOTE: Always try to cut at the fastest speed you can while keeping an accurate cut. Cutting too slowly will waste blade life and lower production!

6. Near the end of the log, slow down the feed rate.
7. When the teeth exit the end of the log.
8. Disengage the clutch.
9. Remove the slab that you have just cut from the log.
10. Return the carriage to the front of the mill.
11. Repeat until the first side of the log is cut as desired.
12. Lower the toe boards, if used.
13. Remove the clamp and turn the log 90 or 180 degrees (against the side support or log bed).

NOTE: If the log was turned 90 degrees and you are using toe boards for a tapered log, raise the appropriate toe board on the second side of the log to position the log heart parallel with the bed.

14. Repeat the steps 1-13 until the log is square. Cut boards from the remaining cant.

NOTE: Remember to adjust for a 1/16 - 1/8" (1.6-3.2 mm) wide kerf.

4.8 Edging

1. Raise the side supports to 1/2 the height of the flitches, or the boards that need to be edged.
2. Stack the flitches on edge against the side supports.
3. Clamp the flitches against the side supports halfway up the flitch height. (Wider flitches should be placed to the clamp side. When they are edged, flip them over to edge the second side without disturbing the other flitches or without having to pull them from the middle of the stack).
4. Adjust the blade height to edge a few of the widest boards.
5. Loosen the clamp and turn the edged boards over to edge the other side.
6. Repeat steps 2-4.
7. Loosen the clamp and remove the boards that have good clean edges on both sides. Clamp the remaining flitches and repeat steps 2-5.

4.9 Blade Height Scale

The blade height scale is attached to the carriage head frame. It includes:

- blade height indicator
- an inch scale
- a quarter scale

THE INCH SCALE

The height indicator measures from bottom of the blade to the mill bed in inches. **See Fig. 4-6.**

Example: You want to cut 1" (25 mm) random width boards from a log. Position the blade for the first cut. Move the carriage to an even measurement on the inch scale. Make a trim cut. Return the carriage for the second cut and lower it 1 1/8" (29 mm) below the original measurement. (The extra 1/8" (3 mm) allows for saw kerf and shrinkage of the lumber.)

NOTICE The yellow area on the scale identifies where the blade could encounter a side support or log clamp. Check that these items are below the blade level before sawing.

THE QUARTER SCALE

The magnetic quarter scale has four sets of marks, each representing lumber thickness. **Saw kerf and shrinkage allowance are included**, but actual board thickness will vary slightly depending on blade thickness and tooth set. **See Fig. 4-7.**

Make a trim cut. Lower the carriage to the next mark on the scale. This mark shows where the blade should be positioned to cut a certain thickness of lumber, without having to measure on the inch scale.

Example: You want to cut 1" (25 mm) (4/4) random width boards from a log. Position the blade for the first cut. quarter scale so a 4/4 mark is aligned with the line on the indicator. Make a trim cut. Return the carriage for the second cut. Lower the blade so the indicator is aligned with the next 4/4 mark on the quarter scale.

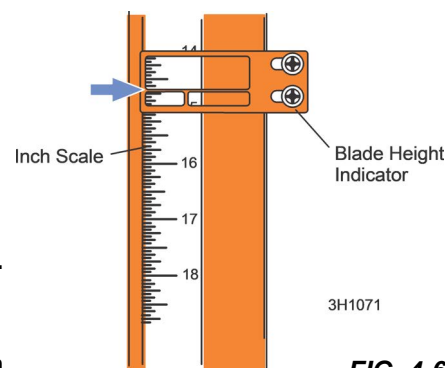

FIG. 4-6

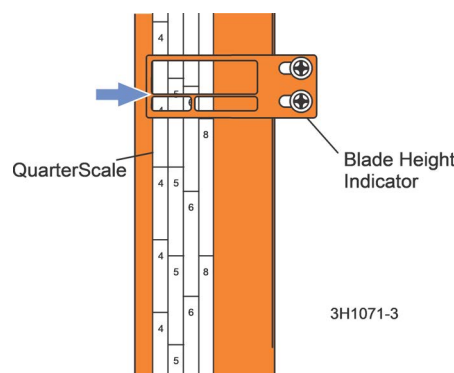

FIG. 4-7

4.10 Water Lube Operation

The Water Lube System keeps the blade clean. Water flows from a 5-gallon (18.9 liter) bottle through a hose to the blade guide where the blade enters the log. A valve in the bottle cap controls the amount of water flow. **See Fig. 4-8.**

Not all types of wood require the use of the Water Lube System. When it is needed, use only enough water to keep the blade clean. This lowers the risk of staining the boards. Average flow will be 1-2 gallons (3.8-7.6 liters) per hour.

Before removing the blade, engage the blade. Let the blade spin with water running on it for about 15 seconds. This will assist cleaning the blade of sap buildup. Wipe the blade dry with a rag before storing or sharpening.

For further lubrication benefits, add one 12oz. (0.35L) bottle of Wood-Mizer Lube Additive to 5 gallons (18.9 liters) of water. Wood-Mizer Lube Additive reduces resin buildup on the blade, heat buildup, wavy cuts, and blade noise. This biodegradable and environmentally friendly pre-mix includes a water softener additive.

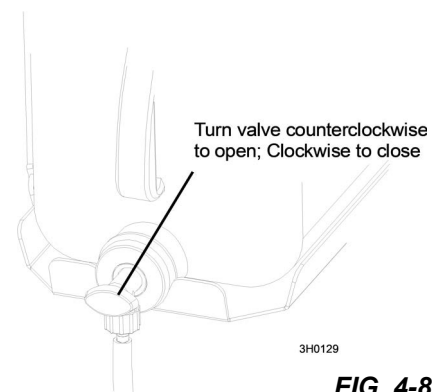

FIG. 4-8

WARNING! DO NOT use flammable fuels or liquids as diesel fuel as solvents in the lube tank such. Remove the blade for cleaning.

CAUTION! Use windshield washer fluid with a freezing point of at least -20°F (-29°C) to the water tank and prime as recommended when sawing or storing the sawmill in below-freezing temperatures.

4.11 Preparing The Sawmill For Towing

1. Move the saw carriage to the front end of the sawmill.
2. Raise the rear outriggers.

CAUTION! Ensure the outrigger base is adjusted properly before securing the FAO in position with the lock pin. Failure to do so will cause damage to the outrigger grease fitting.

Do not adjust the FAO outrigger base height while there is weight on the FAO. Damage to the FAO may result.

3. Move the clamp all the way in toward the main bed frame tube.
4. Raise the log turner and loader as high as they will go.

CAUTION! Move the hydraulic clamp and turner to provide maximum ground clearance before towing. Failure to do so may result in damage to the sawmill.

5. Manually lift the loader and hook the loader chain to the elbow of the turner.
6. Use the hydraulic turner lever to lower the turner until the chain is tight.
7. Push the loader lever down to bring the loader arm channels up to the loader.
8. Release the blade tension.
9. Lift the turner arm up and place the travel plate under the turner to secure the arm above the sawmill bed.

CAUTION! Changes in temperature could cause increased pressure in the blade tensioner and loss of fluid from the gauge. Release the blade tension when the mill is not in use to avoid damage to the tensioner.

10. Move the carriage forward to the travel position over the rear bed rail.
11. Position the hole in the saw head over the travel rest pin. **See Fig. 4-9.**
12. Lower the saw head until it is seated firmly on the rest pin, minimum of 3/4" into the bracket.
13. If necessary, adjust the stop bolt located at the bottom of the mast so the saw head contacts them after it is lowered 3/4" (19mm) past where it contacts the rest pin.

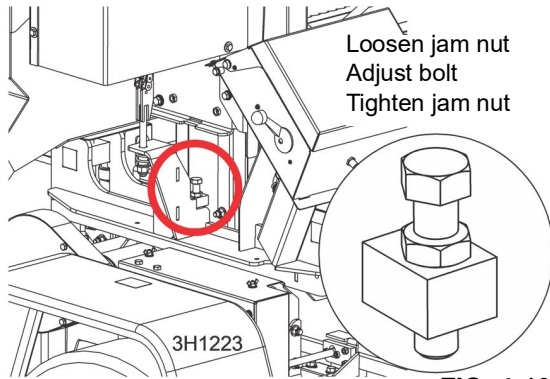

FIG. 4-10

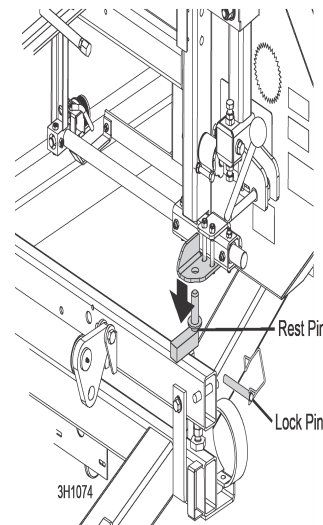

FIG. 4-9

14. Engage the clutch.

This keeps the drive belt tight and the motor from bouncing while traveling. *Ensure to disengage the clutch after reaching the destination to avoid deformation of the drive belt.*

15. Hook the carriage safety chain (located at the bottom of the carriage) to the bracket at the bottom of the mast.



CAUTION! Check to ensure the saw head safety chain is secured before towing the sawmill. Failure to properly secure the saw head can result in severe machine damage. Ensure the blade housing and pulley covers are in place and secure. Use the safety retainer pin and cable to fasten blade housing covers.

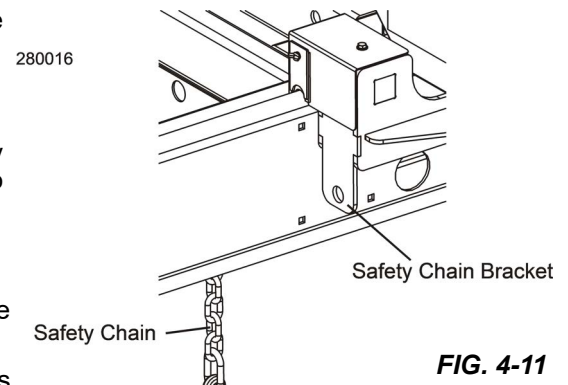

FIG. 4-11

16. Remove all loose objects from the bed of the mill.

- 1). Store the outrigger jack handle in the bracket provided on the rear/loading-side outrigger guide.
- 2). Place both fenders in the slots located behind the trailer tires and secure with rubber straps.
- 3). Raise all but the very front outrigger.

NOTE: For optional Fine Adjust Outriggers (FAOs), adjust the outrigger base height so that the grease fitting is just below the lowest outrigger hole before securing the FAO in position with the lock pin.





CAUTION! Ensure the outrigger base is adjusted properly before securing the FAO in position with the lock pin. Failure to do so will cause damage to the outrigger grease fitting.

Do not adjust the FAO outrigger base height while there is weight on the FAO. Damage to the FAO may result.

See the trailer operator's manual for specific information regarding hitch operation and towing the sawmill.

SECTION 5 MAINTENANCE

 **WARNING!** Before performing service near moving parts such as blades, pulleys, motors, belts and chains, first turn the key switch to the OFF (#0) position and remove the key. If the key is turned on and moving parts activated, serious injury may result.

 **WARNING!** Disconnect and lockout power before performing any service to the electrical system. For battery-powered equipment, disconnect the negative battery terminal cable. For AC-powered equipment, follow the lockout procedure provided in the safety section ([See Section 2.2](#)). Failure to do so may result in injury and/or electrical system damage.

This section lists the maintenance procedures that need to be performed.

See the [Maintenance Chart](#) for a complete list of maintenance procedures and intervals. Keep a log of machine maintenance by recording in the machine hours and the date you perform each procedure.

Refer to option and engine manuals for other maintenance procedures.

5.1 Wear Life

Table 5-1 lists estimated life expectancy of common replacement parts if proper maintenance and operation procedures are followed. Due to the many variables which exist during sawmill operation, actual part life may vary significantly. This information is provided for scheduling replacement parts.

Part Description	Estimated Life
Up/Down Motor Brushes	1000 hours
B57 Blade Wheel Belts	400 hours
Up/Down Motor	2000 hours
Up/Down Switch	1000 hours
Blade Guide Rollers	1000 hours
Power Feed Switch	1200 hours
Power Feed Motor	1500 hours
Up/Down Belt	2000 hours
Drive Belt	1250 hours

TABLE 5-1

5.2 Blade Guides

Check the rollers for performance and wear every blade change.

Ensure the rollers are clean and spinning freely. If not, replace them.

Replace any rollers which have worn smooth or have become cone shaped.

5.3 Sawdust Removal

 **WARNING!** Fire hazard. Clean sawdust from all guards, vents, control boxes, blade wheel housings, or any area where sawdust may gather **after every shift**. Failure to do so may result in fire, causing death or serious injury.

Keep clear of exiting sawdust. Keep hands, feet and any other objects away from the sawdust chute when operating sawmill.

Check that the steel fingers inside the sawdust chute are in place before operating the sawmill.

The steel fingers have been designed to help prevent a broken blade or some other object from becoming a projectile and exiting the sawdust chute. Failure to have these fingers in place may result in serious injury.

1. Remove the excess sawdust from the blade wheel housings and sawdust chute every blade change.
2. Remove all sawdust and debris from around the velocity fuse valves every 8 hours of operation. (The valves are located at the bottom of the optional log loader cylinders.)
3. Remove sawdust and debris from grounding block along the bed rail and mast.

5.4 Carriage Track, Wiper & Scraper

Properly maintaining the sawmill carriage track is critical in preventing corrosion that can cause pitting and scaling on the rail surfaces. Pitted and scaled surfaces can, in turn, cause rough cuts or jerky power feed movement.

 **CAUTION!** Keep track rails free of rust. Formation of rust on the track rail in the areas where the cam bearings roll can cause rapid deterioration of the track rail's surface.

1. Clean track rails to remove any sawdust and sap buildup every eight hours of operation.
 - 1). Use a light-grade sandpaper or emery cloth to sand off any rust or other adhering particles from the rails.

2). Lubricate the rails by wiping them with Dexron III ATF transmission fluid or equivalent. Lubrication will help protect the rails from corrosive elements such as acid rain and/or moisture from nearby bodies of saltwater (if applicable). This lubrication is essential to maintain the integrity of the track rails and track rollers and to achieve long service life.

2. Remove the track roller housing covers and brush any sawdust buildup from the housings every twenty-five hours of operation.
3. Clean and lubricate the felt track wipers every twenty-five hours of operation.
 - 1). Unbolt the middle track cover, remove from the sawmill and remove any sawdust buildup.
 - 2). Soak the felt wiper with Dexron III transmission fluid.

CAUTION! Reinstall the track wiper so that it lightly touches the track rail. If the wiper presses too firmly against the rail, it can cause the power feed to bind.

4. Check that the track scrapers fit firmly against the rail.

If a track scraper needs to be adjusted, loosen the screw, push the scraper downward until it fits firmly against the rail, and retighten the screw.

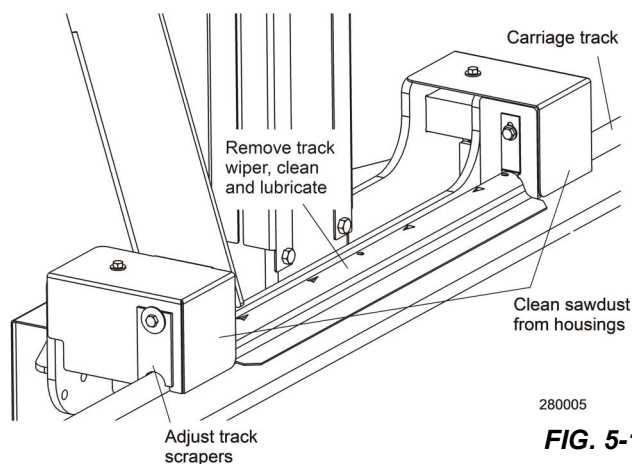

280005

FIG. 5-1

5.5 Vertical Mast Rails

Clean the vertical mast rails every 50 hours of operation.

CAUTION! Grease on the mast rails will collect sawdust. Use Dexron III transmission fluid or equivalent.

5.6 Miscellaneous

1. Oil all chains with Dexron III transmission fluid or equivalent every fifty hours of operation.

CAUTION! Chain lube causes sawdust buildup in chain links. Use Dexron III transmission fluid or equivalent. When lubricating the chains, it is important not to get fluid in the clutch mechanism. Transmission fluid in the clutch mechanism can damage the clutch. Remove any excess fluid from the chains and the clutch mechanism.

2. Grease the optional loading arm and side support pivots with a NLGI No. 2 grade lithium grease every fifty hours of operation.
3. Check the mill alignment every setup ([See Section SECTION 7](#)).
4. Ensure all safety warning decals are readable. Remove sawdust and dirt. Replace any damaged or unreadable decals immediately. Order decals from your Customer Service Representative.

5.7 Blade Wheel Belts

Rotate the blade wheel belts and check them for wear every 50 hours. Rotating the belts will provide longer belt life. Replace belts as necessary with only B57 belts supplied by Wood-Mizer.

5.8 Drive Belt Adjustment

WARNING! Disconnect and lockout power before performing any service to the electrical system. For battery-powered equipment, disconnect the negative battery terminal cable. For AC-powered equipment, follow the lockout procedure provided in the safety section ([See Section 2.2](#)). Failure to do so may result in injury and/or electrical system damage.

Do not adjust the engine drive belts or belt support bracket with the engine running. Doing so may result in serious injury.

CAUTION! Do not over-tighten the drive belt. Damage to the engine may result

Measure the belt tension with a gauge every 50 hours. See Table 5-2 for drive belt tension specifications

NOTE: Wood-Mizer offers a belt tension gauge (Part No. 016309) that will let you accurately measure the belt tension.

Engine/Motor	New Belt Installation/New Sawmill Operation				Subsequent Adjustment		
	Deflection Inches (mm)	Installation Force lbs. (kg)	Check After First	Acceptable Force lbs. (kg)	Then Check Every	Deflection Inches (mm)	Force lbs. (kg)
ALL	7/16" (11mm)	14 lbs. (6.35kg)	20 hrs	14 lbs. (6.35kg)	50 hrs	7/16" (11mm)	14 lbs. (6.35kg)

TABLE 5-2

Adjust the drive belt tension

1. Loosen the drive belt jam and hex nuts. Turn the jam nut counterclockwise (as viewed from the top) to tighten the belt.
2. **GAS OPTION ONLY:** After tensioning the drive belt, check the throttle linkage and adjust if necessary.

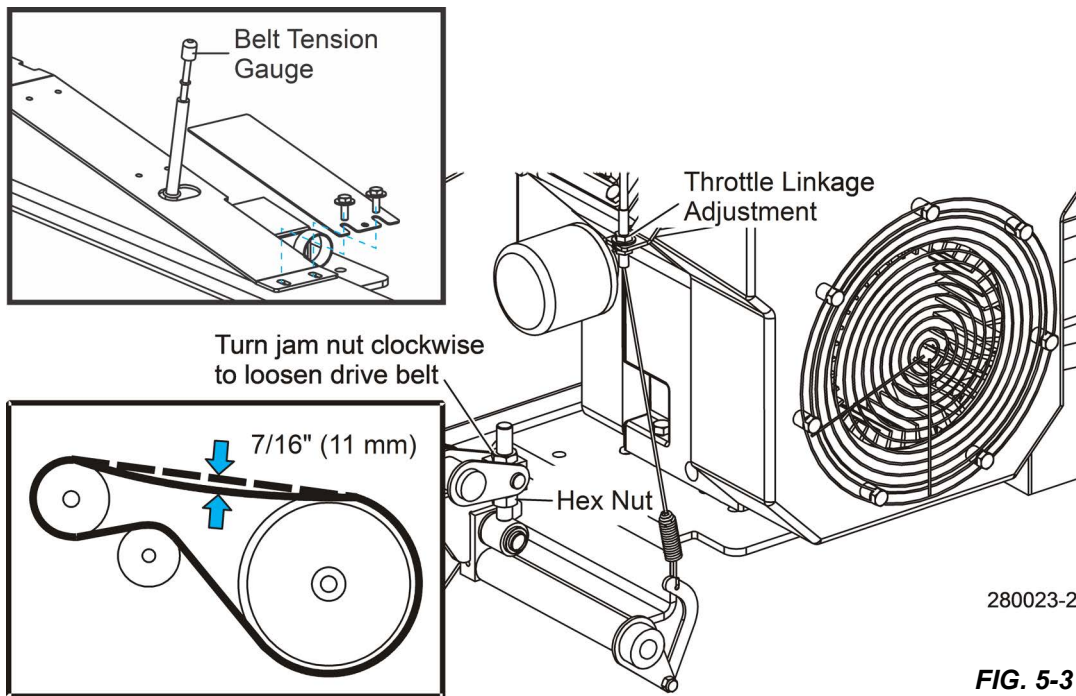

FIG. 5-3

NOTE: With the clutch handle engaged, the throttle linkage should move the throttle lever to full speed. To adjust, loosen the throttle linkage adjustment nuts and slide the throttle linkage down. Retighten the screw.

Periodically check the drive belt for wear. Replace any damaged or worn belts as needed.

Adjust the drive belt support

The drive belt support is designed to extend belt life. The bracket should be adjusted to NOT touch the drive belt when the clutch handle is engaged (down position), AND to hold the drive belt away from the engine pulley when the clutch handle is disengaged (up position).

Adjust the drive belt support as needed. Depending on your engine model, the drive belt support may be located near the drive wheel or drive pulley.

1. Ensure the power is off.
2. Loosen the adjustment bolt.
3. Position the bracket so that the rod is close to, but does not touch, the drive belt with the clutch handle engaged. This is approximately 1/8-1/16" (3-1.5mm).
4. Retighten the adjustment bolt 25-27 pound feet (34-37 newton meters).

5.9 Hydraulic System

1. Check the hydraulic fluid level every fifty hours of operation.

Add fluid as necessary. The level in the hydraulic pump should be 3/4" (19mm) from the top with all cylinders collapsed.

2. If used in a humid environment, drain and replace two quarts (.95 liters) of fluid every six months.

This will drain any accumulated water and help prevent pump failure due to water ingestion. It also will prevent excessive fluid wear and allow the fluid to maintain its hot end performance.

3. If humidity is not a problem, drain and replace one gallon (3.8 liters) of fluid every year to prevent fluid wear.

If you are operating in temperatures -20° to 100° F (-29° to 38° C), use an all-weather hydraulic fluid such as Conoco MV32. For alternate fluids and/or other temperature ranges, refer to the chart below. Operating above the recommended temperature range of a fluid could result in excessive pump wear. Operating below the recommended temperature range could result in reduced hydraulic cylinder speed. To change fluid types, replace one gallon of the current fluid with one gallon of the alternate fluid.

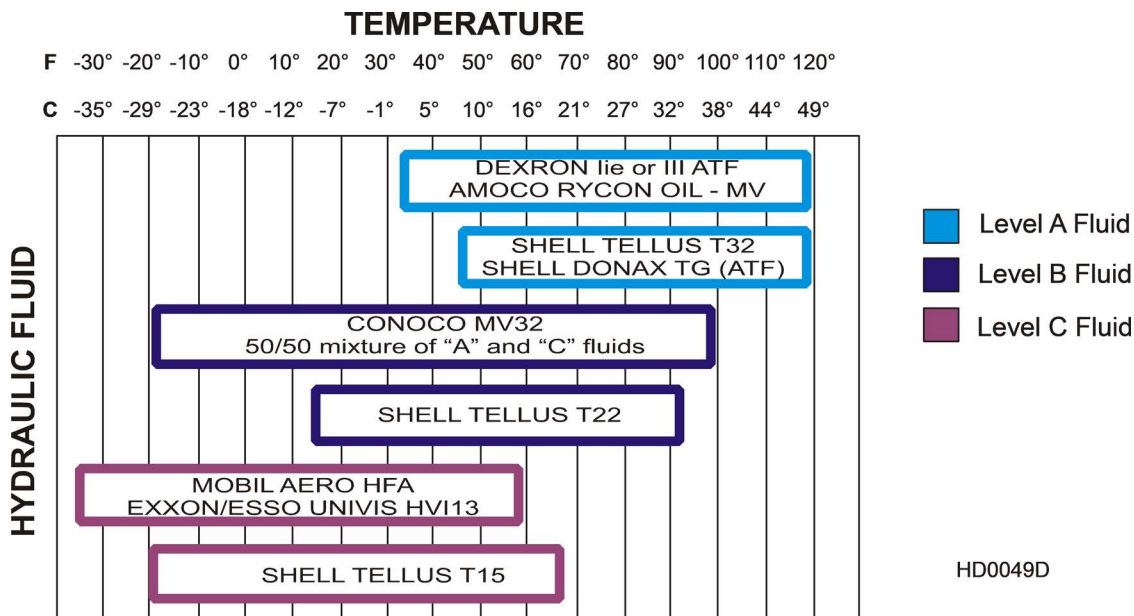

FIG. 5-4

4. Replace the hydraulic system cartridge filter every 500 hours of operation.
5. Inspect the hydraulic pump motor brushes every 750 hours of operation. Remove brush dust and replace the brushes if they worn to a length of 1/4" (6mm) or shorter.

CAUTION! Do not operate the hydraulic system if the pump motor brushes are worn shorter than 1/4" (6mm). Damage to the pump motor may result.

6. Periodically check all hydraulic lines and fitting as needed. Replace as necessary.

5.10 Up/Down System

WARNING! Secure the saw head with a 5/16" chain with at least 1900 lbs. working load capacity before adjusting the up/down chain. The cutting head may fall, causing severe injury or death.

1. Adjust the up/down chain tension as needed. **See Fig. 5-5.**
 - 1). Measure the up/down chain tension with the head all the way to the top of the vertical mast.
 - 2). Secure the saw head as described above.
 - 3). Use the adjustment nut (at the bottom of the mast) to adjust chain until the center can be deflected 3/4" (1.9cm) forward and 3/4" (1.9cm) backward with a 5 lb. (2.3 Kg) deflection force.

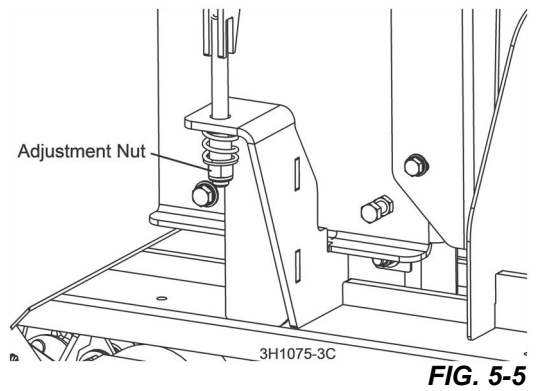

2. Adjust the up/down motor belt as needed. **See Fig. 5-6.**
 - 1). Remove the up/down housing cover.
 - 2). Loosen the motor mount bolts.
 - 3). Pull the motor upward so there is 3/8" (9.5 mm) deflection with a 5 lb. (2.3 Kg) deflection force.
 - 4). Retighten the motor mount bolts.
 - 5). Replace the drive pulley cover.

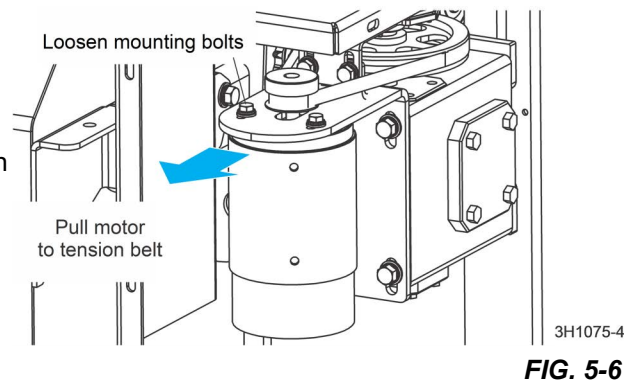

3. Periodically check and replace any damaged or worn belts.
4. Check the up/down gearbox oil level. Add a synthetic gear oil such as Mobil Glygoyle 460 as needed.
5. Drain and refill the gearbox with 24 (0.7L) ounces of oil after every 5000 hours of sawmill operation or every 2 years, whichever comes first.

NOTE: Wood-Mizer offers replacement gear oil in 8 ounce (0.24L) bottles.

5.11 Power Feed

1. Adjust the power feed chain as needed. **See Fig. 5-7.**
 - Move the saw head to the front of the mill.
 - Use the two lock nuts at the rear of the mill to tighten or loosen the power feed chain.
 - Adjust the chain until it the slack measures 7 to 8 inches (17.8 to 20.3 cm) from the top of the top rail at its lowest point.

CAUTION! Do not overtighten the feed chain. Damage to the power feed motor may result.

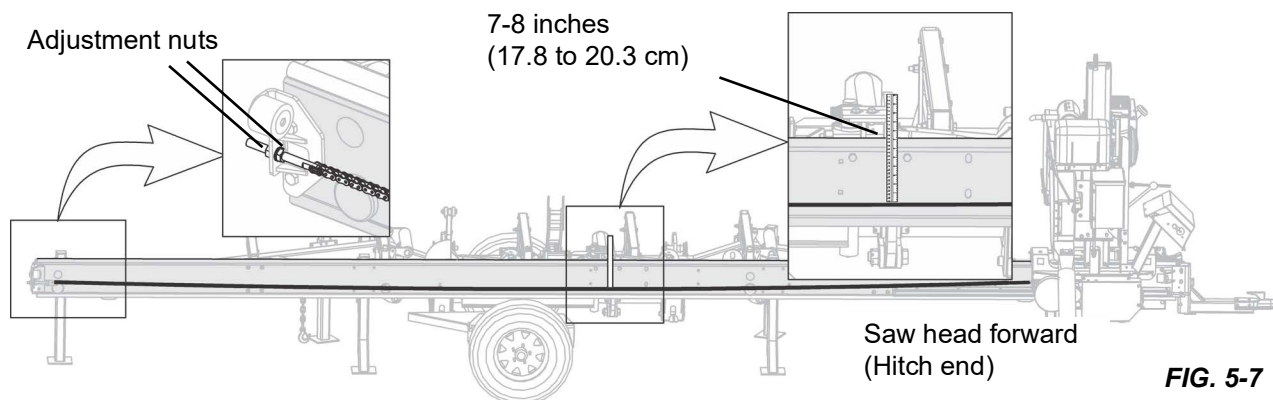

2. Adjust the power feed belt as needed. When the power feed belt gets loose, it will begin slipping. This causes the carriage to not move forward when cutting. To retighten the belt:
 - Remove the power feed belt cover.
 - Loosen mounting bolts
 - Pivot the motor so that the motor pulley moves away from the large feed pulley.
 - Tighten the belt so there is 1/8" (3 mm) deflection with a 7 lb. (3.2 Kg) deflection force.
 - Retighten the motor bolts and replace the feed motor cover.

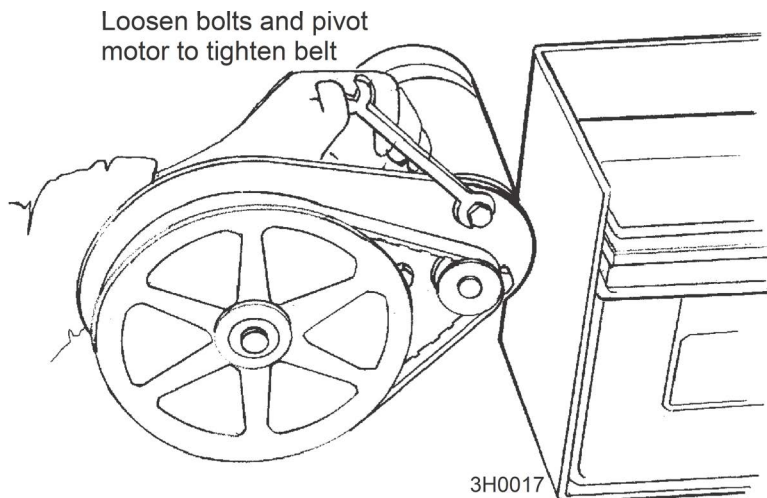

FIG. 5-8

5.12 Charging The Battery

DANGER! Batteries expel explosive gases. Keep sparks, flames, burning cigarettes, or other ignition sources away at all times.

WARNING! Battery posts, terminals and related accessories contain lead and lead compounds, chemicals known to the State of California to cause cancer and reproductive harm. Wash hands after handling.

Always wear safety goggles and a face shield when working near batteries.

Charge the battery in a well ventilated area.

Do not attempt to charge a frozen battery.

Use extreme care to avoid spilling or splashing electrolyte (which is dilute sulfuric acid) which can destroy clothing and burn the skin.

EMERGENCY TREATMENT FOR CONTACT WITH BATTERY COMPONENTS (LEAD/SULFURIC ACID) *per SDS (Safety Data Sheet):*

EYE CONTACT	Sulfuric Acid and Lead: Flush eyes immediately with large amounts of water for at least 15 minutes while lifting lids. Seek immediate medical attention if eyes have been exposed directly to acid.
SKIN CONTACT	Sulfuric Acid: Flush affected area(s) with large amounts of water using deluge emergency shower, if available, shower for at least 15 minutes. Remove contaminated clothing, including shoes. If symptoms persist, seek medical attention. Wash contaminated clothing before reuse. Discard contaminated shoes. Lead: Wash immediately with soap and water.
INGESTION	Sulfuric Acid: Administer large amounts of water. Do NOT induce vomiting or aspiration into the lungs may occur and can cause permanent injury or death; consult physician.
INHALATION	Sulfuric Acid: Remove to fresh air immediately. If not breathing, give artificial respiration. If breathing is difficult, give oxygen. Consult a physician. Lead: Remove from exposure, gargle, wash nose and lips; consult physician.

If electrolyte is spilled or splashed on any surface of the machine, it should be neutralized and rinsed with clean water.

CAUTION! Do not overcharge the battery. Overcharging may reduce the overall service life of the battery.

Ensure the battery is fully charged before transporting the sawmill. If the battery is not fully charged, excessive vibration could reduce the overall service life of the battery.

1. Remove the battery box lid.
2. Clean the battery terminals if necessary.
3. Connect the positive charger/jumper cable directly to the positive battery terminal.
4. Connect the negative charger/jumper cable to a grounded metal surface.
5. Follow the instructions supplied with your specific battery charger.

NOTICE Be careful not to overcharge the battery, especially when using a high-rate or “boost” charger (40 amps or higher). These are intended to quickly charge a good battery that is discharged. They are not intended for unattended or long-term charging.

6. After the battery is completely recharged, remove the negative charger/jumper cable from ground.
7. Remove the positive charger/jumper cable from the battery.
8. Replace the battery box lid and replace the flat washers and wing nuts.

5.13 Maintenance chart

MAINTENANCE LOG (Check <i>Engine And Option Manuals</i> for additional maintenance procedures)	MANUAL REFERENCE	MAINTENANCE INTERVAL
Clean sawdust from all guards, vents, control boxes, blade wheel housings, or any area where sawdust may gather	See Section 5.3	8 hours
Clean and lubricate top/bottom track	See Section 5.4	8 hours
Check blade guide roller wear	See Section 5.2	8 hours Every blade change
Inspect fingers inside sawdust chute	See Section 5.3	8 hours Every blade change
Remove sawdust from upper track roller housings	See Section 5.4	25 hours
Clean and lubricate upper track wiper	See Section 5.4	25 hours
Clean & lube mast rails	See Section 5.5	50 hours
Grease pivot points and bearings/oil chains	See Section 5.7	50 hours
Rotate drive/idle blade wheel belts/check for wear	See Section 5.9	50 hours
Inspect (optional) hydraulic lines, fuel lines, & fittings	See Section 5.12	50 hours
Check all belt tensions	See Section 5.10 See Section 5.14 See Section 5.15	50 hours
Check (optional) hydraulic fluid level	See Section 5.12	50 hours
Check feed & up/down chain tensions	See Section 5.14 See Section 5.15	50 hours
Check up/down gear box fluid level	See Section 5.14	50 hours
Re-check belt tensions	See Section 5.10 See Section 5.14 See Section 5.15	200 hours
Replace the hydraulic system cartridge filter	See Section 5.12	500 hours
Inspect hydraulic pump motor brushes	See Section 5.12	750 hours

SECTION 6 TROUBLESHOOTING GUIDE

6.1 Sawing Problems

 **WARNING!** Before performing service near moving parts such as blades, pulleys, motors, belts and chains, first turn the key switch to the OFF (#0) position and remove the key. If the key is turned on and moving parts activated, serious injury may result.

PROBLEM	CAUSE	SOLUTION
Blades Dull Quickly	Dirty logs	Clean or debark logs, especially on entry side of the cut
	When grinding teeth, heating too much and causing teeth to soften	Grind just enough metal to restore sharpness to the teeth. Use water/coolant while sharpening blade
	Poor sharpening techniques	Make sure the tip is being sharpened completely (See Sharpener Manual)
Blades Break Prematurely	Poor sharpening techniques	See Sharpener Manual
	Rubber belts on blade wheels worn to a point that blade contacts metal pulley - look for shiny spots on edge of wheels	Change blade wheel belts (B-57)
Blade Does Not Track Right on Drive Wheel	Tension too tight	Tension blade to recommended specifications
	Cant adjustment is incorrect	Readjust
	Flat/worn belts	Replace B-57 belts
Blade Guides Do Not Spin While Cutting	Frozen bearings	Replace bearings
Drive Belts Wear Prematurely or Jump	Engine/motor and drive pulleys out of alignment	Align pulleys.
Boards Thick Or Thin On Ends Or Middle Of Board.	Stress in log which causes log to not lay flat on the bed.	After log has been squared, take equal cuts off opposing sides. Take a board off the top. Turn the log 180 degrees. Take a board off. Repeat, keeping the heart in the middle of the cant, and making it your last cut.
	Set in teeth.	Resharpen and reset blade.
	Bed rails misaligned.	Realign sawmill.
Height Adjustment Jumps or Stutters When Moving Up or Down.	Up/down chain improperly adjusted.	Adjust up/down chain.
Lumber Is Not Square	Vertical side supports not square to bed	Adjust side supports.
	Blade not parallel to bed rails	Adjust bed rails parallel to blade.
	Sawdust or bark between cant and bed rails	Remove particles
	Tooth set problems	Resharpen and reset blade
Sawdust Builds Up On Track	Excessive oiling	Do not oil track
	Track wipers worn	Adjust wipers to firmly contact track
	Track is sticky	Clean track with solvent and apply silicone spray

PROBLEM	CAUSE	SOLUTION
Wavy Cuts	Excessive feed	Slow feed rate
	Improperly sharpened blade (This will be the problem 99% of the time!)	Resharpener blade (See Sharpener Manual - read entire manual!)
	Blade guides improperly adjusted	Adjust blade guides.
	Sap buildup on blade	Use Water Lube.
	Tooth set problem	Resharpener and reset blade

6.2 Electrical Problems

 **WARNING!** Before performing service near moving parts such as blades, pulleys, motors, belts and chains, first turn the key switch to the OFF (#0) position and remove the key. If the key is turned on and moving parts activated, serious injury may result.

Disconnect and lockout power before performing any service to the electrical system. For battery-powered equipment, disconnect the negative battery terminal cable. For AC-powered equipment, follow the lockout procedure provided in the safety section ([See Section 2.2](#)). Failure to do so may result in injury and/or electrical system damage.

PROBLEM	CAUSE	SOLUTION
Up/down Excessively Slow.	Up/down belt loose.	Adjust belt to be as loose as possible without slipping.
	Vertical wear pads too tight.	Adjust pads.
	Worn up/down motor or motor brushes.	Replace up/down motor or motor brushes.
Up/down Or Power Feed Motors Do Not Work.	Worn contacts in switch.	Replace switch.
	Burned-out motor.	Replace motor.
	Bad connection on battery post or loose wire.	Check for loose wire or terminal connections.
Up/Down Or Power Feed Switches Remain Engaged When Switch Is Released.	Worn contacts in switch.	Manually move the power feed or up/down switch back to neutral or "off" position. Replace switch.
Up/Down Or Power Feed Motors Overheat And Lose Power.	System overload or bind occurred.	Correct problem. Allow motor to cool before restarting.
	Normal operation factors exceeded (eg: up/down con- trol jockeyed excessively).	Allow motor to cool before restarting.
Everything Works And Then Cuts Out - Works Again.	Bad battery, fuse, or ground connection.	Check and tighten connections.
Nothing Works Electrically.	Dead battery.	Check for short circuit or turn OFF key.
	Blown fuse.	Replace.
	Corrosion on battery post.	Remove connection and clean posts.
Battery Will Not Stay Charged.	Key switch left ON.	Turn switch OFF when not in use.
	Short in system.	Visually check for bare wires and/or have checked.
	Charging system not function- ing.	Have charging system checked by authorized dealer.

PROBLEM	CAUSE	SOLUTION
	Bad battery cells.	Check fluid levels and add proper solution
	Idle improper.	Adjust low end RPM per engine manual.
	Loose alternator belt.	Check belt tension and tighten if necessary.
	Loose connections at alternator.	Check and tighten connections.

6.3 Power Feed Problems

Follow the instructions below to solve the possible power feed problems.

If the saw head does not go forward but reverse works:

1. Access the power feed control module in the control box,
2. With the key/toggle switch ON put the drum switch in the forward position,
3. When turning the speed control, check the lights on the control module.

Under normal conditions the PWR light is on indicating power is at the control module:

- If PWR light is not on, check the drum switch connections.

Under normal operation the IN light brightens and dims as the feed rate switch is turned up and down:

- If the IN light is always on or always off, the feed rated switch could be wired incorrectly,
- If the IN light is erratic, the feed rate switch is worn.

Under normal operation the OUT light brightens and dims (same as the IN light) as the feed rate switch is turned up and down:

- If the OUT light does not correspond with the IN light, check if the OV or OL lights are on,
- If the OV or OL lights are not on, replace the control module (Part No. 024396-1).

Under normal conditions the OV light should never be on:

- If the OV light is on, there is an over voltage condition. Perform a continuity check on the free wheeling diode with the diode removed from the block. There should be continuity only one direction.

Under normal conditions the OL light should never be on:

- If the OL light is on, there is an overload condition. This could be a mechanical bind. Remove the belt from the power feed motor,
- If the OL light is still on:
- Remove the gate (G) wire from the MOSFET module and apply 12 volts to the gate terminal of the MOSFET (this is the small spade terminal),
- If the saw head tries to go down the track, replace the control module (Part No. 024396-1).
- If it does not go down the track, replace the MOSFET module (Part No. 024387) and control module (Part No. 024396-1).

The saw head does not travel in reverse but forward works:

- Check the drum switch connections.

6.4 Power Feed Variable Feed Rate Switch Test



WARNING! Disconnect and lockout power before performing any service to the electrical system. For battery-powered equipment, disconnect the negative battery terminal cable. For AC-powered equip-

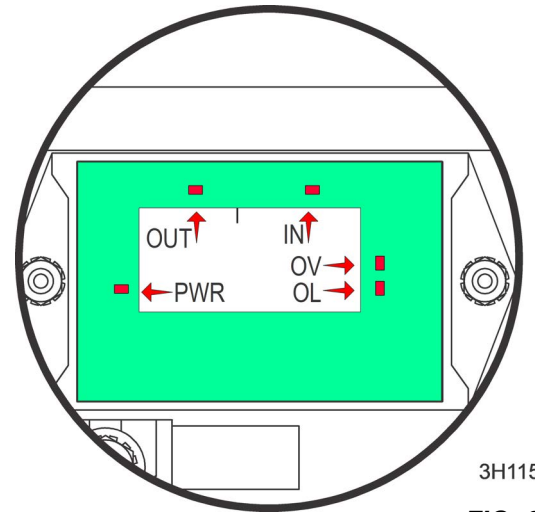

3H1152

FIG. 6-1

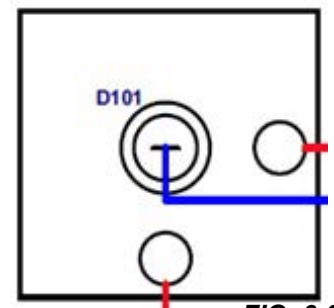

FIG. 6-2

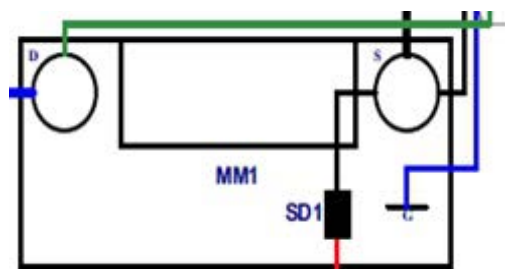

FIG. 6-3

ment, follow the lockout procedure provided in the safety section ([See Section 2.2](#)). Failure to do so may result in injury and/or electrical system damage.

1. With the feed rate dial switch all the way down, move the shaft of the dial back and forth to see if there is a jerky response.
2. Turn the dial and move the shaft back and forth again.
3. Repeat several times.
4. If the jerkiness occurs at the same location on the dial several times, you need to replace the variable speed switch.

6.5 Hydraulic Problems



WARNING! Disconnect and lockout power before performing any service to the electrical system. For battery-powered equipment, disconnect the negative battery terminal cable. For AC-powered equipment, follow the lockout procedure provided in the safety section ([See Section 2.2](#)). Failure to do so may result in injury and/or electrical system damage.



WARNING! Before performing service near moving parts such as blades, pulleys, motors, belts and chains, first turn the key switch to the OFF (#0) position and remove the key. If the key is turned on and moving parts activated, serious injury may result.

PROBLEM	CAUSE	SOLUTION
You Can Actuate Any Hydraulic Handle, But Get No Response From The Pump.	Carriage not positioned properly to provide power to the pump	Make sure carriage contact bracket is adjusted far enough forward for battery positive contact to touch 6ft. strip on main tube. Check contact and strip for tarnish or loose wires. Clean as necessary
	Poor ground connection	Check ground connection between pump and saw frame and between battery negative contact and lower rail. Check contact and rail for tarnish or loose wires. Clean as necessary
	Blown fuse	Replace
	Low or dead battery	Test battery amperage capability (such as low battery charge, low alternator output, defective voltage regulator, bad battery cell, battery age deterioration, etc.). Replace or recharge as necessary
	Poor cable connection	Check cable connection and make sure that battery terminals are in good condition (not corroded)
No Response From The Pump By Actuating Handle	Defective solenoid (may be indicated by solenoid clicking) See Monarch manual for troubleshooting solenoid	After checking all other possibilities for low voltage to solenoid, check solenoid. Tapping on solenoid may fix temporarily. Replace solenoid if necessary. NOTE: The solenoid is not a standard automotive type. Order from Wood-Mizer only
	Defective pump motor	Remove motor from pump and inspect. Repair or replace as necessary
	Electric contact spring inside of non-working valve corroded, broken, or dislocated	Check contact spring. Relocate or replace as necessary
	Set screw holding handle to valve shaft is loose	Tighten set screw so that valve shaft turns when handle is actuated

PROBLEM	CAUSE	SOLUTION
Pump Motor Runs With Little Or No Response From The Cylinders	Low battery	Test battery. Recharge or replace as necessary
	Low fluid level	Check fluid level. Add an all-season hydraulic fluid such as Amoco Rycon Oil MV or Mobil Multipurpose ATF (automatic transmission fluid) until level is 4 - 4 1/2" (100 - 114mm) from bottom of reservoir with all cylinders retracted
	Pressure relief valve moved from proper setting	Adjust pressure relief valve.
Pump Motor Runs Continuously When Power Contact Is Made	Low air temperature causing fluid to thicken	Allow fluid to warm up. Synthetic fluids are available that allow for hydraulic operation in cold weather conditions (Univis HVI 13)
	Solenoid is stuck closed	Tapping the solenoid may solve this problem temporarily. Replace solenoid
	Valve handle spring is deformed or broken, causing the handle to not return to the neutral position	Replace handle spring
Fluid Leaks From Around Cylinder Piston Ram	Contact spring is dislocated and lying across contacts	Replace contact spring
	Worn seals	Replace seals in cylinder. Check piston ram for abrasive weld that may be causing premature seal failure
Fluid Leak Around Pump Box	Loose seal or fitting	Wipe pump off completely to locate cause of leak. You may have to unbolt the pump to wipe behind it. NOTE: Movement of the sawmill can cause fluid to slosh up into the foam filter in the reservoir cap, and subsequently spray out, giving the appearance that fluid is leaking from the pump
Hydraulic Side Supports Go Down Before Or At Same Time As Log Turner	Dirt in sequence valve	Remove sequence valves and clean thoroughly with kerosene. NOTE: Be sure to reassemble the valve and install it in its original position on the cylinder
	Retainer in sequence valve worn	Replace sequence valve
Hydraulic Turner Goes Up Before Or At Same Time As Side Supports	Low air temperature causing fluid to thicken	Allow fluid to warm up. Synthetic fluids are available that allow for hydraulic operation in cold weather conditions (Univis HVI 13)
	Dirt in sequence valve	Remove sequence valves and clean thoroughly with kerosene. NOTE: Be sure to reassemble the valve and install it in its original position on the cylinder
	Retainer in sequence valve worn	Replace sequence valve
	Low air temperature causing fluid to thicken	Allow fluid to warm up. Synthetic fluids are available that allow for hydraulic operation in cold weather conditions. (Univis HVI 13)

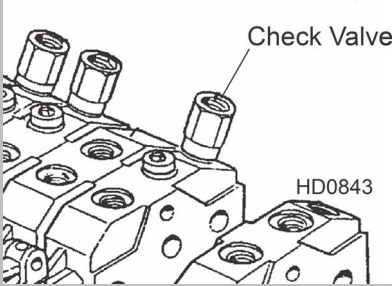
PROBLEM	CAUSE	SOLUTION
<p>Pump runs but makes “growling” sound and hydraulic functions are slow, jerky or don’t work at all.</p>	<p>Low fluid level</p>	<p>Check fluid level and add fluid as necessary. Check for leaks in the system at the control box fittings, hoses and cylinders</p>
<p>One of the log loader cylinders does not move when lowering the loader causing the foot of other to raise completely before loader will start down.</p>	<p>Damaged cylinder shaft</p>	<p>Replace the cylinder that is not moving</p>
<p>(LT35HD version only) Hydraulic Toe Boards “Creep” UP OR DOWN without the valve control handles being operated OR do not raise or lower at all..</p>	<p>Can be a result of shock load caused by improperly using the toe boards to "cushion" or break the fall of a cant onto the bed):</p> <ul style="list-style-type: none"> · damaged hoses · damaged cylinder seals or cylinder · damaged valve 	<p>INITIAL CHECK To check, disconnect the toe board hydraulic hose from its current valve section and temporarily connect it to another valve section. Check to see if the hydraulics operate properly.</p> <p>If hydraulics operate properly, hoses and cylinder seals are good. Perform further valve inspection, found below.</p> <p>If creep still occurs, check all hoses for possible pinholes causing leakage. Replace if applicable. Retest. If creep still occurs, replace cylinder seals or cylinder and retest.</p> <p>Be sure to reconnect the hose to the proper valve section when done.</p> <p>FURTHER VALVE INSPECTION If further inspection of the valve is required after initial check, remove the check valve shown below. Flush the check valve with an air hose or solvent to remove any dirt from the valve's seat. Reinstall and test again. Check to see if the hydraulics operate properly.</p> <p>If creep still occurs, replace the check valve with a new one. Retest. If creep still occurs, replace the hydraulic valve.</p> 
	<p>Bad check valve (results in one of the toe boards experiencing down-creep)</p>	<p>Check the release valve as instructed above. If the release valve is good, replace the high-pressure hydraulic check valves (A12869) located on the pump.</p>

6.6 Hydraulic Pressure Test

TO CHECK HYDRAULIC PRESSURE:

1. Disconnect power from the pump by moving the saw head forward until it no longer contacts the power strip.
2. Locate the loading arm port fitting on the hydraulic valve body. Disconnect the hydraulic hose from the fitting and install a gauge to the fitting. NOTE: Installing the gauge at the loading arm fitting port will insure the pressure reading is not affected by a relief valve.



WARNING! Wear safety goggles and keep people away from area when performing this procedure. Check gauge fitting connection for leaks before activating the hydraulic valve levers. Carefully activate the lever and watch for leaks. Fix any leaks before proceeding. Highly pressurized fluid escaping through a leak may cause serious injury.

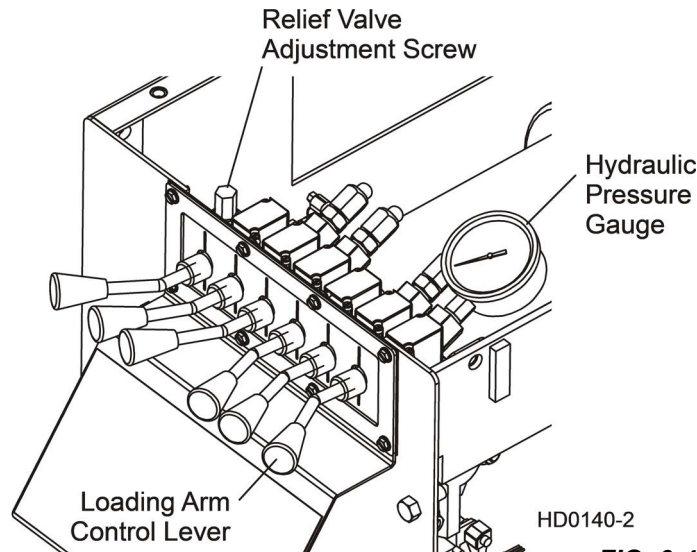

HD0140-2
FIG. 6-4

3. Restore power to the pump by moving the saw head back until it contacts the power strip.
4. Operate the loading arm hydraulic lever and read the pressure on the gauge. Hydraulic pressure is factory-set at 2000 \pm 100 psi and should not need to be readjusted. The relief valve adjustment screw shown may be used to fine-tune the hydraulic pressure:

Remove the adjustment screw nut. Tighten the adjustment screw (clockwise) to increase pressure. Loosen the adjustment screw (counterclockwise) to lower pressure.



CAUTION! Pressure should not exceed 2000 psi. If it does, the amp draw will rise above the design maximum of 200 amps, and could cause battery and system problems. Pressure above 2000 psi may also damage the hydraulic hoses.

6.7 Simple Set Troubleshooting

Error Messages

Simple Set error messages.

Error	Description
E02 Sensor	This message is displayed if Simple Set cannot detect the encoder sensor magnet when entering auto mode. Check that the gear box extension is aligned with the sensor. Push any button on the Simple Set control to exit to manual mode.
E03 Sensor	This message is displayed if Simple Set cannot detect a signal from the encoder sensor when entering auto mode. Check the encoder sensor cable connections. push any button on the Simple Set control to exit to manual mode.

Diagnostic Lights

LED indicator lights are provided on the encoder sensor housing and the display circuit board and H-bridge module inside the Simple Set control box. Observing the LED lights during operation can help identify problems with the sensor, switches or Simple Set control.

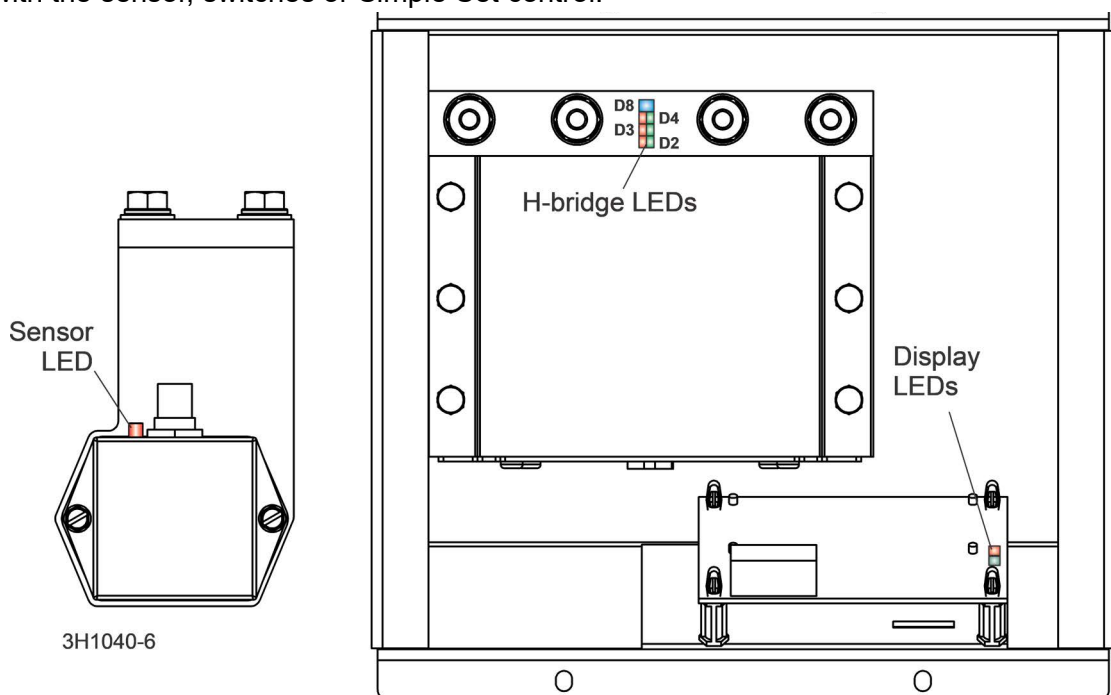

FIG. 6-5

During normal operation:

- As the up/down gearbox shaft spins to move the saw head up or down, the sensor LED will illuminate and brighten. After each complete revolution of the shaft, the LED will turn off then illuminate and brighten.
- In manual mode, the control board LED and the H-bridge D2, D3, D4 LEDs will illuminate (red) when the drum switch is activated in the down direction and (green) when the up/down drum switch is activated in the up direction. The LEDs will turn off when the drum switch is released. The H-bridge D8 LED will be lit blue to indicate the 5 Volt DC output to the control board.
- In auto mode, the control box LED and the H-bridge D2, D3, D4 LEDs will illuminate (green) in the up direction as in manual mode. When the drum switch is bumped in the down direction, the control box LED and the H-bridge D2, D3, D4 LED's will illuminate (red) in the down direction but the control board LED will immediately turn off. When the blade reaches the increment value set by the Simple Set control, the D2, D3, D4 LEDs on the H-bridge will turn off. If the drum switch is held down or the saw head coasts past the increment, the H-bridge D2, D3, D4 LEDs will illuminate (green) indicating the blade will move up to return to the increment value. When the blade reaches the increment value, the H-bridge D2, D3, D4 LEDs will turn off.

Simple Set Up/Down Gear Settings Adjustment

1. Make sure the power to the control box is on.
2. Press and hold the Manual button and then press and hold the UP arrow. Release the Manual button, then release the UP arrow. The Simple Set control panel will display the Speed setting.

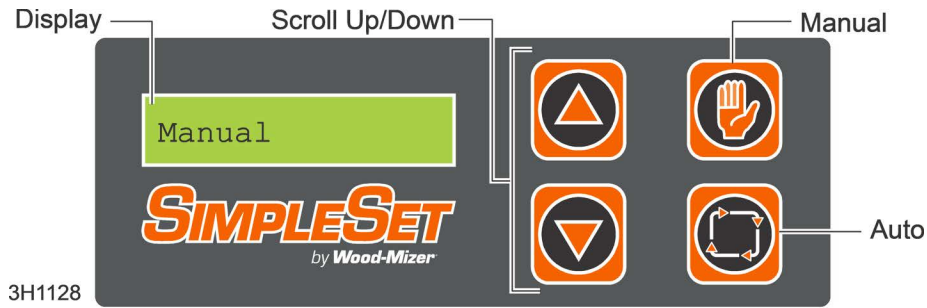

FIG. 6-6

3. Press the Auto button several times until "Gear: 0.xxxx" appears.
4. Use the Up/Down arrow buttons to set the value of the Gear Setting as shown in the table below.

Models	Revision	Gear Setting	InvGear Setting
LT40 (Default)	All	0.0938 (Default)	No (Default)
LT35/LT35HD	Any revision (upgraded with Up/Down Kit 074029)	0.1170	Yes
LT35/LT35HD	A1.00 - A1.02	0.2250	Yes
LT35/LT35HD	A2.00 - A2.01	0.3492	Yes
LT35/LT35HD	A3.00 - A4.01	0.1170	Yes
LT35/LT35HD	A5.00+ (or any revision upgraded with Up/Down Kit 074316)	0.1170	No
LX150	A1.00+	0.1335	Yes

5. Press the Auto button to display "InvGear: xx".
6. Use the Up/Down arrow buttons to set the InvGear setting to the required value as shown in the table above.
7. Press the Manual button to return to the main menu.

Simple Set PID Settings

1. Make sure the power to the control box is on.
2. Press and hold the Manual button and then press and hold the UP arrow. Release the Manual button, then release the UP arrow. The Simple Set control panel displays the Speed setting.
3. Press the Auto button several times until PGain, DGain and IGain settings appear. Use the Up/Down arrow buttons to set the settings to the required values.

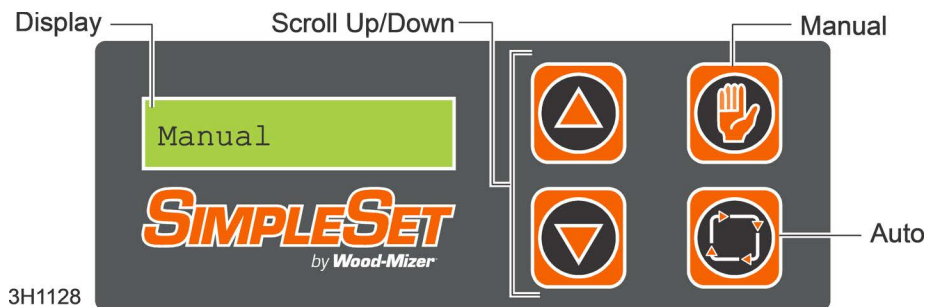

FIG. 6-7

NOTICE The PID settings are factory-set and they should not be changed. If necessary, set the PID settings to the following values: PGain 1.0, DGain 0.0 and IGain 0.0.

4. Press the Manual button to return to the main menu.

Simple Set Troubleshooting (LT35)

Follow the instructions below to solve the possible power feed problems.

If the saw head does not go up or down:

- Disconnect the wires to the up/down motor,
- Jump a volt meter or test light across the two wires going back to the control box,
- With the key/toggle switch on, put the drum switch/joystick in the up position,
- If there is a 12VDC reading, check for stuck or worn motor brushes or replace motor.

If there is no voltage reading:

- Check the lights on the control module: the red light when in the down position and the green light when in the up position,
- If there are no lights, check for voltage at the drum switch terminals.

If the lights are working:

- Check the lights on the h-bridge: the red light when in the down position and the green light when in the up position,
- If there are no lights, replace the control module.

If the lights are good:

- Replace the h-bridge.

Setworks inaccuracy issues:

- If the saw head comes up short of the drop, verify that there are no binds on the mast. If it is good, replace the encoder and cable,
- If the saw head goes long past the drop, verify that the up/down belt is tight. If it is good, replace the encoder and cable.

NOTICE The PGain settings and speed values should never be changed!

SECTION 7 SAWMILL ALIGNMENT

Two alignment procedures are available to realign the sawmill. The Routine Alignment instructions should be performed as necessary to solve sawing problems not related to blade performance. The Complete Alignment procedure should be performed approximately every 1500 hours of operation (sooner if you regularly transport the sawmill over rough terrain).

NOTE: The procedures listed here must be performed in the order they appear.

7.1 Routine Alignment Procedure

Blade Installation

1. Remove the blade and check the blade wheel belts. Remove any sawdust buildup from the surface of the belts. Replace worn belts if they do not keep the blade from contacting the blade wheel.
2. Install a clean blade and apply the appropriate tension ([See Section 3.4](#)).
3. Adjust the idle-side cant control to track the blade ([See Section 3.5](#)).
4. Close the blade housing cover and make sure all persons are clear of the saw head.
5. Start the engine.
6. Engage the blade, rotating the blade until the blade positions itself on the wheels.

WARNING! Do not spin the blade wheels by hand. Spinning the blade wheels by hand may result in serious injury.

7. Disengage the blade. Turn the engine off.

Saw Head Tilt

As the blade enters a wide log or cant, the outside of the saw head will drop down slightly. To compensate for the drop, the saw head is adjusted 1/16" (1.5 mm) higher at the outside.

1. Move the saw carriage so the blade is positioned over a bed rail.
2. Adjust the blade guide arm to 1/2" (15 mm) from full open.
3. Raise the saw head so the bottom of the blade measures 14 3/4" (375 mm) from the top surface of the bed rail near the inner blade guide assembly.
4. Measure from the blade to the bed rail near the outer blade guide assembly. This measurement should be 1/16" (1.5 mm) higher than the inner measurement or 14 13/16" (376.5 mm).

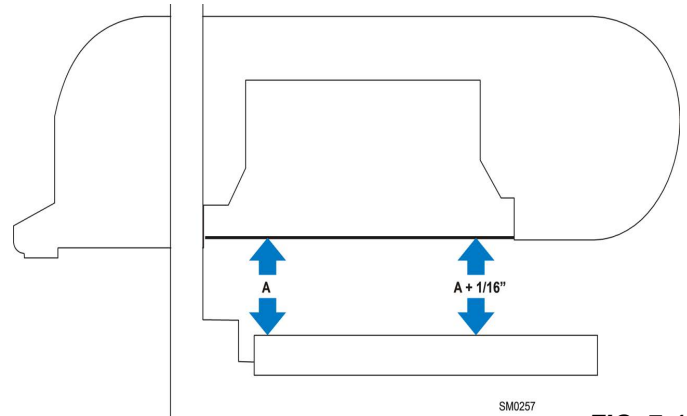

FIG. 7-1

5. Use the horizontal adjustment nuts to raise the outside of the saw head, tighten the two adjustment nuts. **See Fig. 7-2.**
6. Recheck the measurement from the blade to the bed rails and adjust the horizontal adjustment nuts until the outside of the saw head is 1/16" (1.5mm) higher than the inside.

Blade Guide Arm Alignment

The blade guide arm moves the outer blade guide in and out. If the arm becomes loose, the blade guide will not deflect the blade properly, causing inaccurate cuts. A loose blade guide arm can also cause blade vibration.

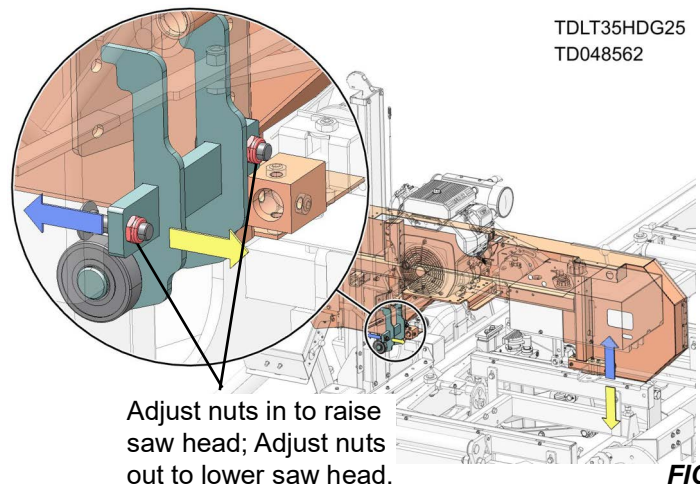

FIG. 7-2

7 Sawmill Alignment

Blade Guide Vertical Tilt Alignment

1. Adjust the blade guide arm out to 1/2" (13 mm) from fully open.
2. Use the inside top and bottom screws to adjust the arm up until the slide pad touches the saw head brace tube.
3. Tighten the jam nuts.
4. Adjust the blade guide arm in all the way toward the other blade guide.
5. Use the outside top and bottom screws to adjust the arm up until the slide pad touches the saw head brace tube.
6. Tighten the jam nuts.

NOTE: When adjusting the blade guide arm screws, be careful not to tighten the screws too much or put the arm in a bind. Operate the blade guide arm to ensure the arm moves easily in and out.

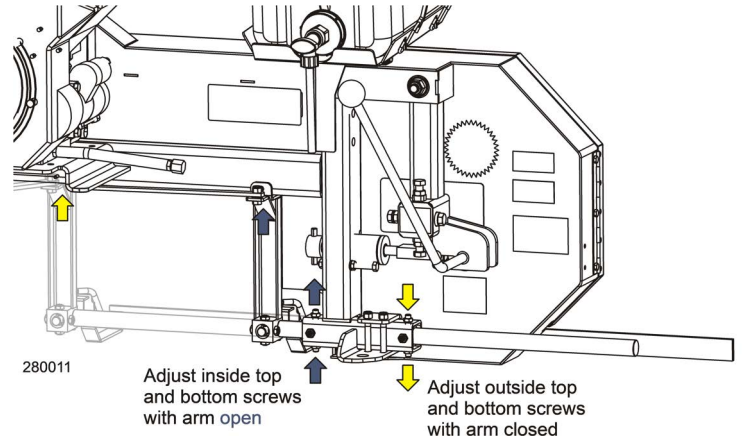

FIG. 7-3

7. With the blade guide arm still all the way in toward the other blade guide, tighten all the side screws until they touch the arm.
8. Back the screws off 1/4 turn and tighten the jam nuts.

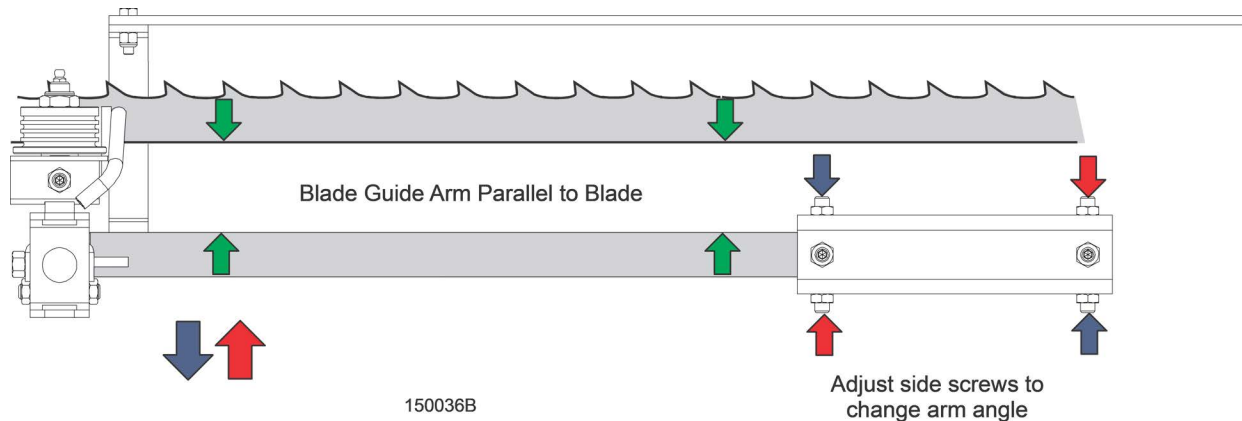

FIG. 7-4

9. Measure the distance between the blade guide arm and back edge of the blade.
10. Adjust the appropriate side screws on the blade guide arm housing so the arm is measures the same distance from the blade at both ends of the arm.
11. To move the blade guide end of the arm toward the front of the sawmill, loosen jam nuts on the front inside screw and the rear outside screw. **See Fig. 7-4.**
12. Turn the screws counterclockwise one full turn and tighten the jam nuts.
13. Loosen the jam nuts on the front outside screw and the rear inside screw.
14. Turn the screws clockwise until they touch the arm, back off 1/4" turn, and tighten the jam nuts.
15. To move the blade guide end of the arm toward the rear of the sawmill, loosen jam nuts on the front outside screw and the rear inside screw.
16. Turn the screws counterclockwise one full turn and tighten the jam nuts.
17. Loosen the jam nuts on the front inside screw and the rear outside screw.
18. Turn the screws clockwise until they touch the arm, back off 1/4" turn, and tighten the jam nuts.

Blade Guide Vertical Tilt Alignment

The blade guides should be adjusted properly in the vertical plane. If the blade guides are tilted vertically, the blade will try to travel in the tilted direction.

A Blade Guide Alignment Tool (LTBGAT) is provided to help you measure the vertical tilt of the blade.

1. Open the adjustable blade guide arm 1/2" (13 mm) from full open.
2. Clip the alignment tool on the blade. **See Fig. 7-5.**
3. Position the tool close to the outer blade guide assembly.

Ensure the tool does not rest on a tooth or burr, and is lying flat against the bottom of the blade.

4. Move the carriage so that the front end of the tool is positioned above the bed rail. Measure the distance from the bed rail to the bottom edge of the tool.
5. Move the carriage so that the back end of the tool is positioned above the bed rail. Measure the distance from the bed rail to the bottom edge of the tool.

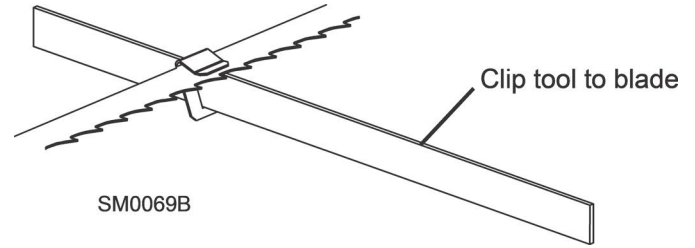

FIG. 7-5

6. If the measurement from the tool to the bed rail is not equal within 1/32" (.75 mm), adjust the vertical tilt of the outer blade guide roller.

7. Loosen one set screw at the side of the blade guide assembly. **See Fig. 7-6.**
8. Loosen the jam nuts on the top and bottom vertical tilt adjustment screws.

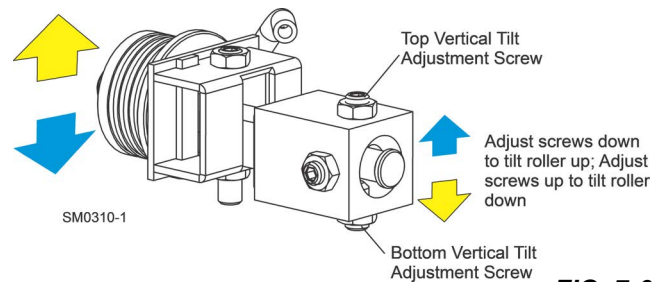

FIG. 7-6

- 1). To tilt the roller up, loosen the bottom screw and tighten top screw.
- 2). Reverse this to tilt down.
- 3). Tighten the jam nuts and recheck the tilt of the blade.

9. Move the blade guide alignment tool close to the inner blade guide roller assembly and repeat the above steps.
10. Adjust the vertical tilt of the inner blade guide if necessary.

Blade Guide Horizontal Tilt Adjustment

If the blade guides are tilted in the wrong direction horizontally, the back of the blade may contact the flange as the roller is spinning down, causing it to push the blade away from the guide roller.

1. Remove the blade guide alignment tool from the blade and adjust the blade guide arm halfway in.
2. Remove the clip from the blade guide alignment tool and place the tool against the face of the outer blade guide roller. **See Fig. 7-7.**
3. Measure between the back edge of the blade and the tool at the end closest to the inner blade guide ("B").
4. Measure between the back edge of the blade and the other end of the tool ("A").

The roller should be tilted slightly to the left ('A' 1/8" [3 mm] less than 'B' ±1/8" [3 mm]).

5. Loosen the jam nuts on the horizontal tilt adjustment screws. **See Fig. 7-7.**
 - 1). To tilt the roller left, loosen the right screw and tighten left screw.
 - 2). Reverse to tilt right.
 - 3). Tighten the jam nuts and recheck the tilt of the blade.

6. Repeat the above steps for the inner blade guide roller assembly.

NOTE: Once the blade guides have been adjusted, any cutting variances are most likely caused by the blade.

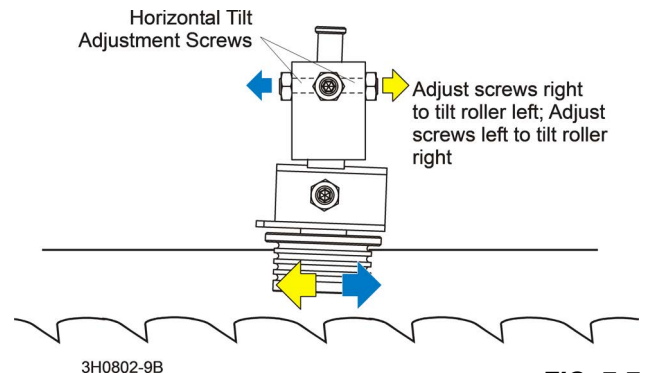

FIG. 7-7

Blade Guide Flange Spacing

Each blade guide must be adjusted so the roller flange is the correct distance from the back edge of the blade. If the flange is too close to or too far from the blade, the sawmill will not cut accurately.

HINT: When adjusting blade guide spacing, loosen the top set screw and one side set screw only. This will ensure horizontal and vertical tilt adjustments are maintained when the adjustment screws are retightened.

1. Measure the distance between the flange on the outer blade guide roller to the back edge of the blade. This distance should measure 1/8" (3.0 mm). Adjust the roller back or forward if necessary.
2. Loosen the top and one side screw shown. **See FIG. 7-8.**
3. Tap the blade guide forward or backward until properly positioned.
4. Retighten the screws and jam nuts.
5. Measure the distance between the flange on the inner blade guide roller to the back edge of the blade.

This distance should measure 1/16" (1.5 mm). Adjust the roller back or forward if necessary.

Side Support Alignment

Logs and boards are clamped against the side supports when sawing. The sides supports must be square to the bed to ensure square lumber.

1. Swing a side support down and measure between the face of the support and the main bed tube.

The distance at the top of the side support ('B') should be equal to or no more than 1/32" (0.8 mm) greater than the distance at the base of the side support ('A'). Adjust the horizontal tilt of the side support if necessary.

2. Loosen the two adjustment plate mounting bolts. **See Fig. 7-9.**
3. Use a mallet to move the plate until the side support is parallel to the bed tube in the horizontal position.
4. Retighten the mounting bolts.
5. Repeat the horizontal check for the remaining side supports. Adjust as necessary.
6. Place square alignment tubes (Part No. S12831 - 2 required) across the bed rails. Swing a side support up so that it is vertical.
7. Pull back at the top of the support to eliminate slack as if a log were being clamped against it.
8. Place a square against the face of the side support.

The side support should be square or slightly tilted forward 1/32" (0.8 mm). Adjust the vertical tilt of the side support if necessary.

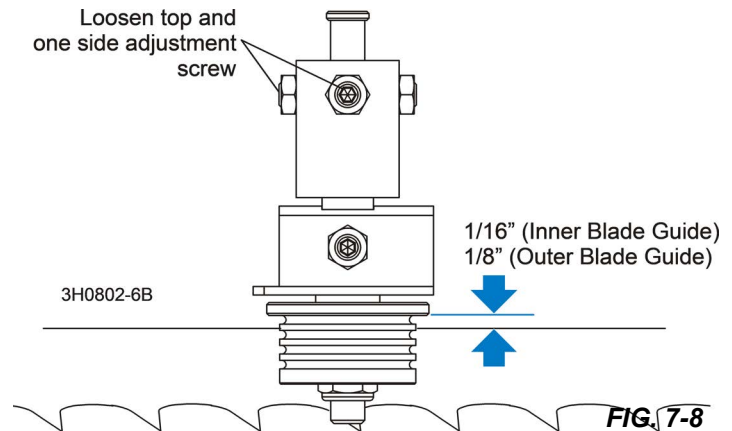

FIG. 7-8

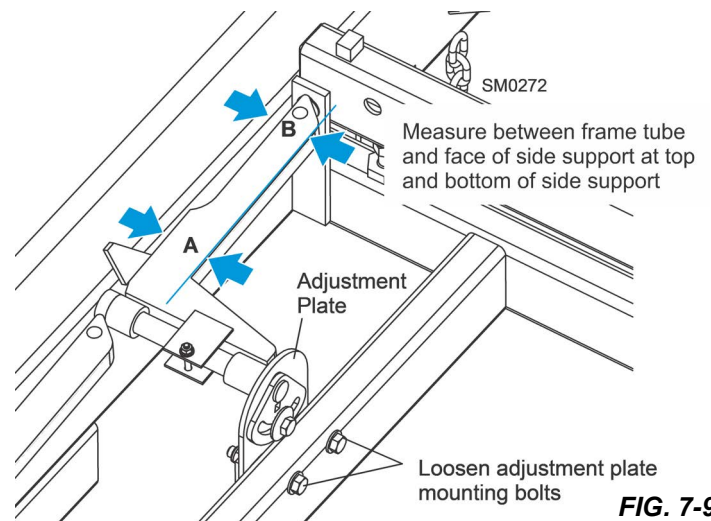

FIG. 7-9

9. Loosen the side support mounting bolt. Use a 3/8" ratchet to rotate the pin until the side support is square to the bed.
10. Repeat the vertical check for the remaining side supports and adjust as necessary.

Blade Height Scale Adjustment

After the entire sawmill has been aligned and all adjustments made, check that the blade height scale indicates the true distance from the blade to the bed rails.

1. Move the saw carriage so the blade is positioned directly above one of the bed rails.
2. Measure from the bottom edge on a down-set tooth of the blade to the top of the bed rail, near the inner blade guide assembly.
3. View the blade height scale with eyes level with the indicator. **See Fig. 7-11.**

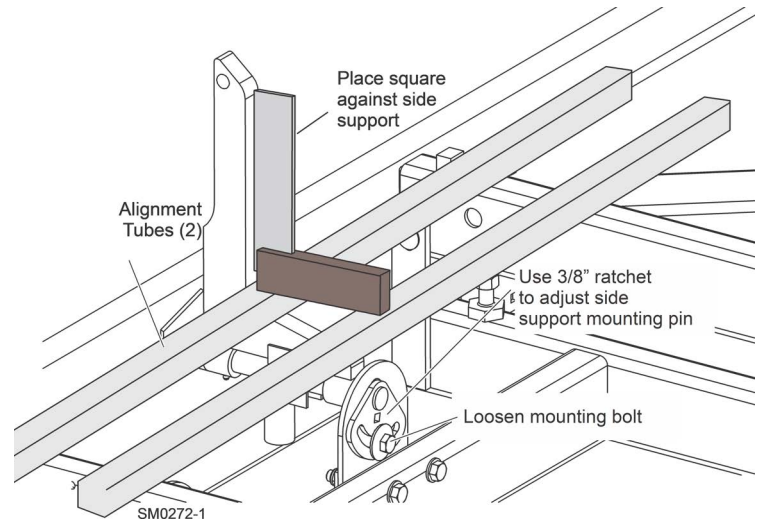

FIG. 7-10

The scale should indicate the actual distance from the blade to the bed rail. Adjust the indicator if necessary.

4. Loosen the indicator bracket mounting nut.
5. Adjust the bracket up or down until the indicator is aligned with the correct mark on the scale (+0 -1/32 [0.8 mm]).
6. Retighten the indicator mounting nut.

Example: If the measurement from the down-set tooth of the blade to the bed rail was 14 3/4" (375 mm), make sure the indicator reads 14 3/4" (375 mm) on the scale.

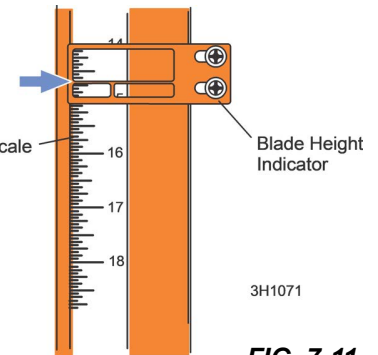

FIG. 7-11

7.2 Complete Alignment Procedure

NOTE: The procedures listed here must be performed in the order they appear

Frame Setup

Before performing the following alignment procedures, setup the mill on firm, level ground.

If your sawmill is stationary, with no trailer axle, shim the feet so the weight of the sawmill is evenly supported.

If your sawmill has a trailer axle and adjustable outriggers, adjust the outriggers as follows:

Adjust the two outriggers on the main frame tube down just enough to lift weight from the trailer tire.

Adjust the two outer outriggers down just so they touch the ground but do not bear weight.

See [SECTION 3](#) for additional setup information.

Blade Installation

1. Remove the blade and replace the blade wheel belts. New blade wheel belts are required to perform the complete alignment procedure.
2. Blow sawdust off of the blade guide assemblies. Remove sawdust from the blade housings.
3. Remove the blade guide assemblies.

NOTE: To remove the blade guide assemblies and maintain the tilt adjustments, only loosen one side screw and the top screw. Leaving the other side screw and bottom screw in position will insure you will return the rollers to their original tilt adjustment.

4. Adjust the outer blade guide arm in or out until the outer blade guide is approximately 24" from the inner blade guide.

5. Install a new blade and apply the appropriate tension ([See Section 3.4](#)).
6. Close the blade housing cover and make sure all persons are clear of the saw head.
7. Start the engine.
8. Engage the blade, rotating the blade until the blade positions itself on the wheels.

WARNING! Do not spin the blade wheels by hand. Spinning the blade wheels by hand may result in serious injury.

9. Disengage the blade. Turn the engine off.

Saw Head Tilt [See "Saw Head Tilt" on page 7- 1](#)

Blade Wheel Alignment

The blade wheels should be adjusted so they are level in the vertical and horizontal planes. If the blade wheels are tilted up or down, the blade will want to travel in the tilted direction. If the blade wheels are tilted horizontally, the blade will not track properly on the wheels.

1. Attach the blade alignment tool to the blade near the inner blade guide mount.

Ensure the tool does not rest on a tooth or burr, and is lying flat against the bottom of the blade.

2. Move the saw carriage so the front end of the tool is positioned over the first bed rail. Measure from the bottom of the tool to the top surface of the bed rail.

3. Move the saw carriage so the rear of the tool is positioned over the bed rail.

4. Again, measure from the bottom of the tool to the bed rail.

5. If the two measurements differ by more than 1/16" (1.5 mm), adjust the vertical tilt of the drive-side blade wheel.

6. Use the vertical adjustment screws to adjust the drive-side blade wheel. **See FIG. 7-13.**

1). To tilt the wheel down/up, loosen the top/bottom adjustment screw one quarter turn.

2). Loosen the jam nut on the bottom/top adjustment screw and tighten the screw.

3). Tighten the top and bottom jam nuts.

7. Recheck the vertical tilt of the drive-side blade wheel with the blade guide alignment tool.

8. Readjust the blade wheel as necessary until the front and rear of the tool are the same distance from the bed rail (within 1/16" [1.5 mm]).

9. Remove the tool from the blade and reattach it near the outer blade guide assembly.

10. Measure from the tool to the bed rail at both ends of the tool. If the measurements at the front and rear ends of the tool differ by more than 1/16" (1.5 mm), adjust the vertical tilt of the idle-side blade wheel.

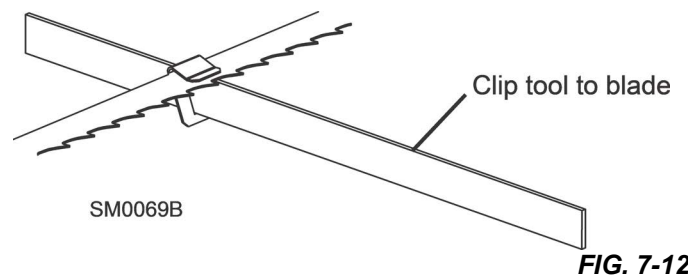
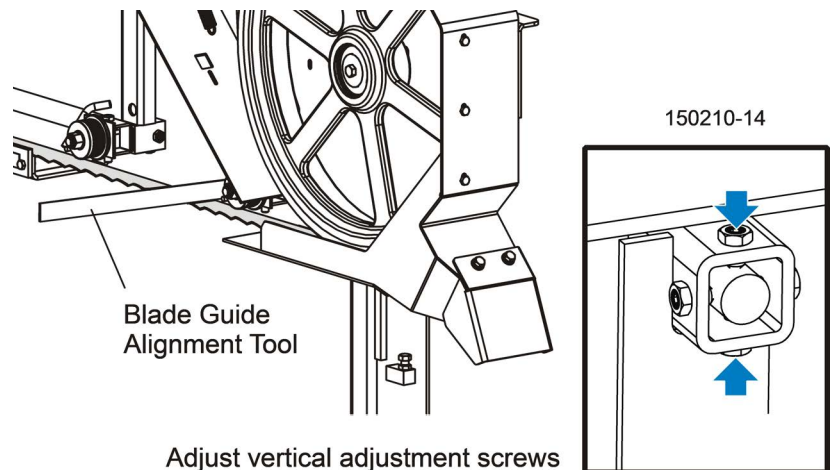

FIG. 7-12



Adjust vertical adjustment screws down to tilt drive-side blade wheel up; Adjust screws up to tilt wheel down

FIG. 7-13

11. Measure from the tool to the bed rail at both ends of the tool. If the measurements at the front and rear ends of the tool differ by more than 1/16" (1.5 mm), adjust the vertical tilt of the idle-side blade wheel.
12. Use the vertical adjustment screws to adjust the idle-side blade wheel.
 - 1). To tilt the wheel down/up, loosen the top/bottom adjustment screw one quarter turn.
 - 2). Loosen the jam nut on the bottom/top adjustment screw and tighten the screw.
 - 3). Tighten the top and bottom jam nuts.
13. Recheck the vertical tilt of the idle-side blade wheel with the blade guide alignment tool.
14. Readjust the blade wheel as necessary until the front and rear of the tool are the same distance from the bed rail (within 1/16" [1.5 mm]).
15. Check the position of the blade on the idle-side blade wheel.

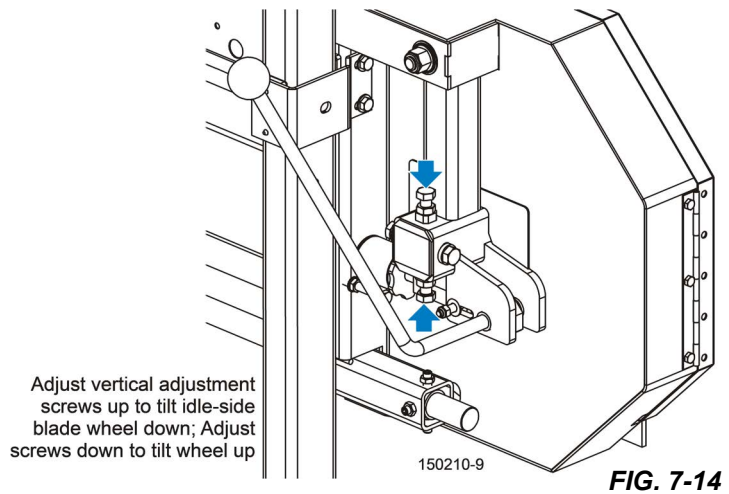

The horizontal tilt of the blade wheel should be adjusted so that the gullet of an 1-1/4" blade is 1/8" (3 mm) out from the front edge of the wheel ($\pm 1/32$ [0.75 mm]).

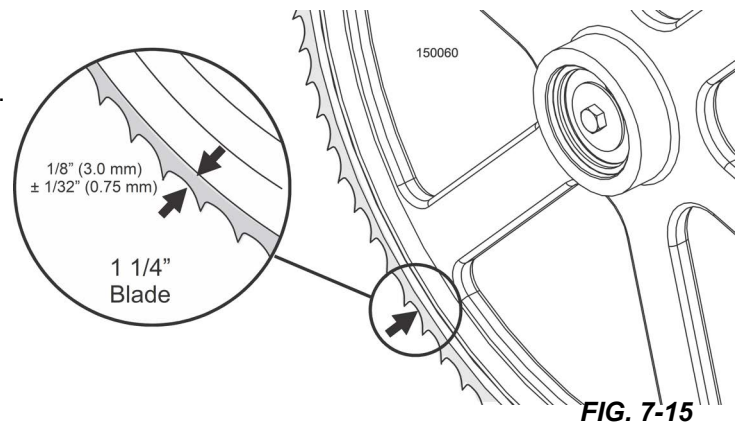

16. Use the cant control adjustment to adjust the idle-side blade wheel.
17. If the blade is too far forward on the wheel, turn the cant control counterclockwise. Reverse if it is too far back on the wheel.

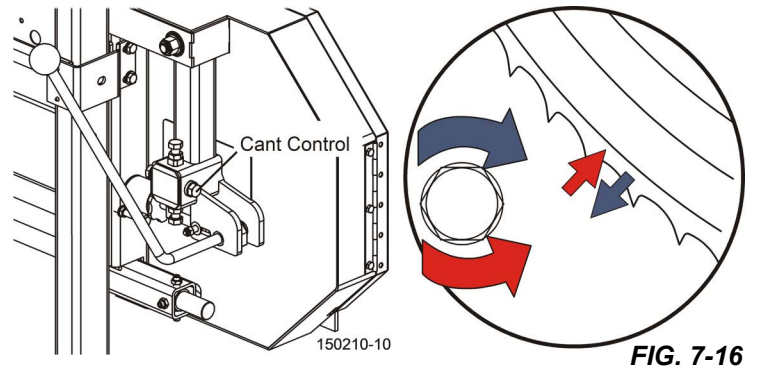

18. Check the position of the blade on the drive-side blade wheel.

The blade should be positioned on the wheel as described for the idle-side blade wheel.

19. Adjust the drive-side blade wheel if necessary.
20. Use the horizontal adjustment screws to adjust the drive-side blade wheel.
 - 1). To move the blade back/forward on the wheel, loosen the right/left adjustment screw one quarter turn.
 - 2). Loosen the jam nut on the left/right adjustment screw and tighten the screw.
 - 3). Tighten the left and right jam nuts.

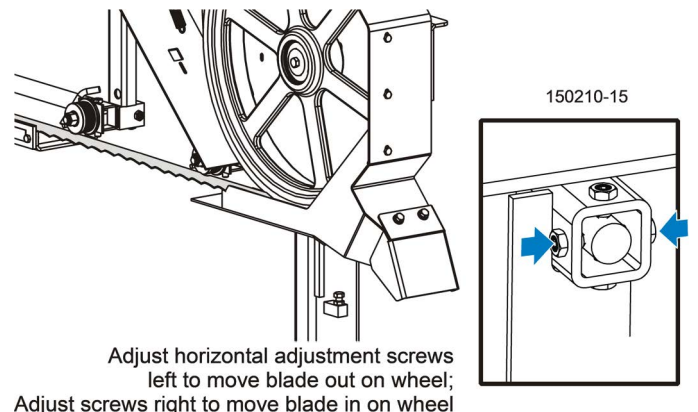

Bed Rail Adjustment

1. Install the log clamp at its lowest setting in a hole where the clamp is positioned 10" (254mm) from the clamp stop (fourth hole from stop). **See Fig. 7-18.**
2. Move the saw head until the blade is centered over the clamp.
3. Raise the saw head until the blade measures 14 1/2" (360 mm) from the top of the clamp.
4. Use a rule to determine the actual distance of the blade to the clamp.
5. Adjust the front pivot rail 90° to the main bed tube.
6. Move the saw head to center the blade over the front pivot bed rail.
7. Measure the distance from the top of the pivot rail to the bottom of the blade. Make this measurement at each end of the pivot rail.

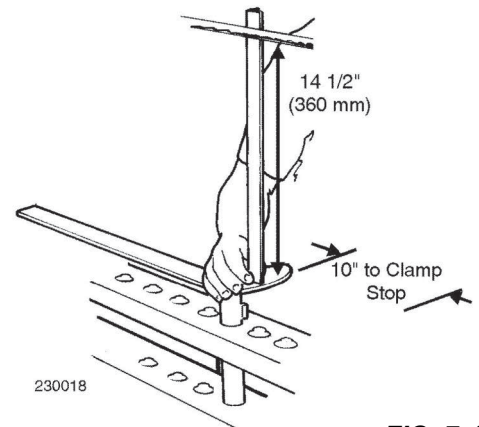

FIG. 7-18

The two measurements should be 15" (375 mm).

8. Loosen the locking set screws and turn the inner height adjustment nut to adjust the height of the inner end of the pivot rail.
9. Loosen the jam nut and turn the outer adjustment bolt to adjust the height of the outer end of the pivot rail.
10. Move the saw head so the blade is positioned over the center of the front main bed rail.
11. Measure the distance between the bottom of the blade and the bed rail at each end of the bed rail.

The bed rail should measure 15" (375 mm) from the blade at each end of the rail.

12. Loosen the bed rail clamping bolts and turn the adjustment bolts to move the bed rails to the blade if necessary.
13. Retighten the clamping bolts and adjustment bolt jam nuts.
14. Without adjusting the saw head height, check the three remaining main bed rails and the rear pivot rail.
15. Adjust all rails so that they all measure the same distance from the blade at both ends of the bed rail.

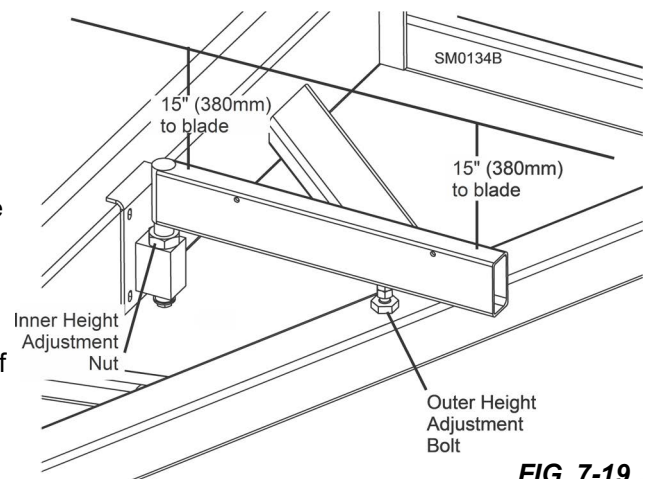

FIG. 7-19

Blade Guide Installation

NOTE: Before installing the blade guide assemblies, remove the blade guide adjusting screws and apply a lubricating oil such as 10W30 or Dexron III to each screw. This will prevent the screws and threaded holes from corroding and make screw adjustments easier.

1. Install the outer blade guide assembly (with waterlube tube) to the mounting block on the blade guide arm. Position the assembly so the roller flange is 1/8" (3.0 mm) from the blade.
2. Install the inner blade guide assembly to the mounting block on the saw head.

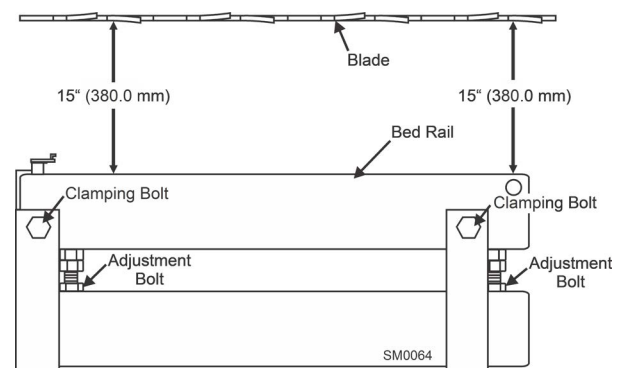

FIG. 7-20

- Position the assembly so the roller flange is 1/16" (1.5 mm) from the blade.
- Tighten the two previously-loosened tilt adjustment screws to secure the blade guide assembly. **See Fig. 7-21.**
- Loosen the top vertical adjustment jam nut and tighten the bottom vertical adjustment jam nut to adjust the blade guide roller up so it does not touch the blade.

Blade Guide Arm Alignment See "[Blade Guide Arm Alignment](#)" on page 7- 1

Blade Guide Deflection

- Raise the saw head until the blade is 15" (375 mm) above a bed rail.
- Measure the actual distance with a rule from the top of the rail to the bottom of the blade.

Ensure the two vertical adjustment set screws are threaded into the blade guide shaft until they touch each other.

- Loosen the bottom jam nut and tighten the top jam nut until the blade guide deflects the blade down until the bottom of the blade measures 14 3/4" (370 mm) from the bed rail. **See Fig. 7-21.**
- Repeat for the other blade guide.

NOTE: Be sure that the blade guide deflector rod clears the blade on both guide assemblies. The rod on the outer guide assembly should be checked with the arm all the way in and all the way out.

Blade Guide Vertical Tilt Alignment See "[Blade Guide Vertical Tilt Alignment](#)" on page 7- 2

Blade Guide Horizontal Tilt Adjustment See "[Blade Guide Horizontal Tilt Adjustment](#)" on page 7- 3

Blade Guide Flange Spacing See "[Blade Guide Flange Spacing](#)" on page 7- 4

Side Support Alignment See "[Side Support Alignment](#)" on page 7- 4

Clamp Stop/Stop Bolt Adjustment

- Once the side supports are aligned, pivot them down to their horizontal position.
- Tie a string to the stop block at the first bed rail.
- Stretch the string toward the rear of the frame and tie to the stop block at the last bed rail.
- Loosen the clamp stop bolts and adjust the clamp stop until it touches the string.
- Loosen the jam nut and adjust the bolt on the middle-rear bed rail until it touches the string.

Blade Height Scale Adjustment See "[Blade Height Scale Adjustment](#)" on page 7- 5

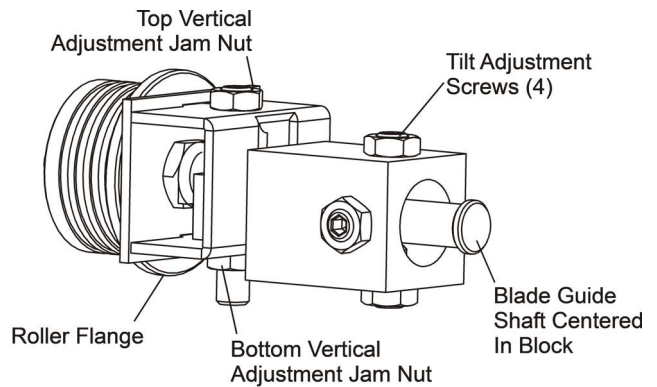

3H0802-15
FIG. 7-21

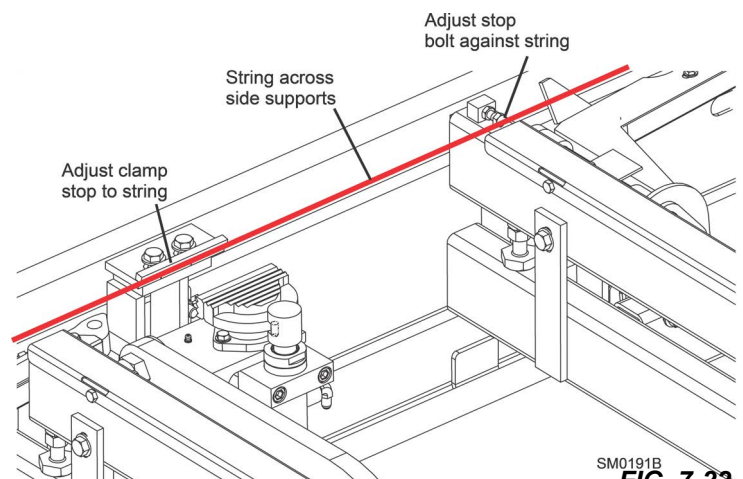

SM0191B
FIG. 7-22