

# Wood-Mizer® Resaw

## Safety, Operation & Maintenance Manual

---

HR120  
HR130

Rev. A1.00 - A4.08  
Rev. A1.00 - A6.02

---



**Safety is our #1 concern!** Read and understand all safety information and instructions before operating, setting up or maintaining this machine.

*May 2010*

*Form #1626*

**©2019**

Printed in the United States of America, all rights reserved. No part of this manual may be reproduced in any form by any photographic, electronic, mechanical or other means or used in any information storage and retrieval system without written permission from

***Wood-Mizer***  
**8180 West 10th Street**  
**Indianapolis, Indiana 46214**

## California

### Proposition 65 Warning



**WARNING:** Breathing gas/diesel engine exhaust exposes you to chemicals known to the State of California to cause cancer and birth defects or other reproductive harm.

Always start and operate the engine in a well-ventilated area.

If in an enclosed area, vent the exhaust to the outside.

Do not modify or tamper with the exhaust system.

Do not idle the engine except as necessary.

For more information go to [www.P65warnings.ca.gov](http://www.P65warnings.ca.gov).



**WARNING:** Drilling, sawing, sanding or machining wood products can expose you to wood dust, a substance known to the State of California to cause cancer. Avoid inhaling wood dust or use a dust mask or other safeguards for personal protection.

For more information go to [www.P65Warnings.ca.gov/wood](http://www.P65Warnings.ca.gov/wood).

# Table of Contents

# Section-Page

# Table of Contents

# Section-Page

<b>ABOUT THIS MANUAL</b>		<b>I-VII</b>
<b>SECTION 1</b>	<b>SAFETY</b>	<b>1-1</b>
1.1	Safety Symbols.....	1-1
1.2	Safety Instructions.....	1-2
	<i>Observe Safety Instructions .....</i>	<i>1-2</i>
	<i>Wear Safety Clothing .....</i>	<i>1-2</i>
	<i>Keep The Machine And Area Around The Machine Clean... 1-3</i>	<i>1-3</i>
	<i>Handle Fuel/Lubricants Safely .....</i>	<i>1-3</i>
	<i>Dispose Of Sawing By-Products Properly.....</i>	<i>1-3</i>
	<i>Use Caution When Working With Batteries.....</i>	<i>1-3</i>
	<i>Check Machine Before Operation.....</i>	<i>1-5</i>
	<i>Keep Persons Away.....</i>	<i>1-5</i>
	<i>Keep Hands Away.....</i>	<i>1-5</i>
	<i>Cautions For Gas Or Diesel Engine Operation .....</i>	<i>1-6</i>
	<i>Use Proper Maintenance Procedures.....</i>	<i>1-7</i>
	<i>Keep Safety Labels In Good Condition.....</i>	<i>1-10</i>
<b>SECTION 2</b>	<b>INTRODUCTION</b>	<b>2-1</b>
2.1	Getting Service.....	2-1
	<i>General Contact Information.....</i>	<i>2-1</i>
	<i>Wood-Mizer Locations .....</i>	<i>2-2</i>
2.2	Specifications .....	2-3
2.3	Customer and Machine Identification .....	2-6
<b>SECTION 3</b>	<b>SETUP</b>	<b>3-1</b>
3.1	Resaw Setup .....	3-1
3.2	Electrical Installation (HR120 E10/HR130 E15 Only).....	3-2
3.3	Upper Hold-Down Adjustment .....	3-4
3.4	Blade Guide Arm Adjustment.....	3-5
3.5	Conveyor Tilt Adjustment.....	3-6
3.6	Shingle Belt Installation (Optional).....	3-7
3.7	Tensioning The Blade.....	3-8
3.8	Replacing The Blade .....	3-9
3.9	Tracking The Blade .....	3-10
3.10	Table Setup (Optional) .....	3-12
<b>SECTION 4</b>	<b>OPERATION</b>	<b>4-1</b>
4.1	Up/Down Operation .....	4-1
4.2	Machine Start.....	4-4
	<i>Gas Models .....</i>	<i>4-4</i>
	<i>Diesel Models.....</i>	<i>4-5</i>
	<i>Electric Models (HR120) .....</i>	<i>4-5</i>
	<i>Electric Models (HR130) .....</i>	<i>4-6</i>
4.3	Clutch Operation .....	4-7
4.4	Feed Operation .....	4-8
4.5	Water Lube Operation .....	4-10
4.6	Shingle Belt Operation (Optional).....	4-12

# Table of Contents

# Section-Page

<b>SECTION 5</b>	<b>MAINTENANCE</b>	<b>5-1</b>
5.1	Blade Guides .....	5-1
5.2	Sawdust Removal .....	5-2
5.3	Vertical Mast Rails .....	5-3
5.4	Blade Wheel Belts .....	5-4
5.5	Drive Belt Adjustment.....	5-5
5.6	Charging The Battery .....	5-7
5.7	Feed System.....	5-9
<b>SECTION 6</b>	<b>ALIGNMENT</b>	<b>6-1</b>
6.1	Complete Alignment Procedure .....	6-1
	<i>Blade Installation.....</i>	<i>6-3</i>
	<i>Blade Wheel Alignment.....</i>	<i>6-4</i>
	<i>Blade Guide Installation.....</i>	<i>6-9</i>
	<i>Blade Guide Arm Alignment.....</i>	<i>6-10</i>
	<i>Blade Guide Deflection.....</i>	<i>6-12</i>
	<i>Blade Guide Vertical Tilt Alignment.....</i>	<i>6-13</i>
	<i>Blade Guide Horizontal Tilt Adjustment.....</i>	<i>6-15</i>
	<i>Blade Guide Flange Spacing.....</i>	<i>6-17</i>
	<i>Blade Height Scale Adjustment.....</i>	<i>6-18</i>
	<i>Conveyor Belt Alignment.....</i>	<i>6-19</i>
<b>SECTION 7</b>	<b>ELECTRICAL INFORMATION</b>	<b>7-1</b>
	<b>INDEX</b>	<b>I</b>

## ABOUT THIS MANUAL

This manual is to replace or to be used with all previous information received on the HR100 Series Resaw. All future mailings will be an addition to or a revision of individual sections of this manual as we obtain new information.

The information and instructions given in this manual do not amend or extend the limited warranties for the equipment given at the time of purchase.

For general information regarding our “Forest to Final Form” products, please refer to the All Products Catalog in your support package.



HR0053

## SECTION 1 SAFETY

### 1.1 Safety Symbols

The following symbols and signal words call your attention to instructions concerning your personal safety. Be sure to observe and follow these instructions.



**DANGER!** indicates an imminently hazardous situation which, if not avoided, will result in death or serious injury.



**WARNING!** suggests a potentially hazardous situation which, if not avoided, could result in death or serious injury.



**CAUTION!** refers to potentially hazardous situations which, if not avoided, may result in minor or moderate injury or damage to equipment.



**IMPORTANT!** indicates vital information.

**NOTE:** gives helpful information.



Warning stripes are placed on areas where a single decal would be insufficient. To avoid serious injury, keep out of the path of any equipment marked with warning stripes.



## 1.2 Safety Instructions

**NOTE:** ONLY safety instructions regarding personal injury are listed in this section. Caution statements regarding only equipment damage appear where applicable throughout the manual.



**WARNING!** Clean sawdust from all guards, vents, control boxes, or any area where sawdust may gather after every shift. Failure to do so may result in fire, causing death or serious injury.



### Observe Safety Instructions



**IMPORTANT!** Read the entire Operator's Manual before operating this machine. Take notice of all safety warnings throughout this manual and those posted on the machine. Keep this manual with this machine at all times, regardless of ownership.

Also read any additional manufacturer's manuals and observe any applicable safety instructions including dangers, warnings, and cautions.



Only persons who have read and understood the entire operator's manual should operate this machine. This machine is not intended for use by or around children.

**IMPORTANT!** It is always the owner's responsibility to comply with all applicable federal, state and local laws, rules and regulations regarding the ownership, and operation of your machine. All machine owners are encouraged to become thoroughly familiar with these applicable laws and comply with them fully while using the machine.



**WARNING!** Use extreme care and proper equipment to lift and move the machine. Lift the machine from sides equipped with fork pockets only, never from under the front or rear of the base or the saw head. Failure to do so may result in personal injury and/or machine damage.

### Wear Safety Clothing



**WARNING!** Secure all loose clothing and jewelry before operating this machine. Failure to do so may result in serious injury or death.

# 1

## Safety

### Safety Instructions

---

**WARNING!** Always wear gloves and eye protection when handling bandsaw blades. Changing blades is safest when done by one person! Keep all other persons away from area when coiling, carrying or changing a blade. Failure to do so may result in serious injury.



**WARNING!** Always wear eye, ear, respiration, and foot protection when operating or servicing this machine.



### **Keep The Machine And Area Around The Machine Clean**



**DANGER!** Maintain a clean and clear path for all necessary movement around the machine and lumber stacking areas. Failure to do so will result in serious injury.

### **Handle Fuel/Lubricants Safely**



**DANGER!** Due to the flammable nature of fuel and oil, never smoke, weld, grind or allow sparks near your engine or storage tanks, especially during times of fueling.

**DANGER!** Never allow fuel to spill on a hot engine during fueling operations or otherwise. The hot temperature of your engine could induce a fire or explosion.



**WARNING!** Store gasoline away from sawdust and other flammable materials. Failure to do so may result in serious injury.

**WARNING!** Use ONLY water and Wood-Mizer Lube Additive with the water lube accessory. Never use flammable fuels or liquids such as diesel fuel. If these types of liquids are necessary to clean the blade, remove it and clean with a rag. Failure to do so can damage the equipment and may result in serious injury or death.

### **Dispose Of Sawing By-Products Properly**



**IMPORTANT!** Always properly dispose of all sawing by-products, including sawdust and other debris.

### **Use Caution When Working With Batteries**

 **DANGER!** Batteries expel explosive gases. Keep sparks, flames, burning cigarettes, or other ignition sources away at all times. Always wear safety goggles and a face shield when working near batteries. Failure to do so will cause serious injury.<sup>1</sup>

 **WARNING!** Battery posts, terminals and related accessories contain lead and lead compounds, chemicals known to the State of California to cause cancer and reproductive harm. Wash hands after handling.

 **WARNING!** Charge the battery in a well ventilated area. Do not attempt to charge a frozen battery.

Use extreme care to avoid spilling or splashing electrolyte (which is dilute sulfuric acid) as it can destroy clothing and burn the skin. If electrolyte is spilled or splashed on clothing or the body, it should be neutralized immediately and then rinsed with clean water. A solution of baking soda, or household ammonia, and water may be used as a neutralizer.

Electrolyte splashed into the eyes is extremely dangerous. If this should happen, force the eye open and flood it with cool, clean water for approximately fifteen minutes. A doctor should be called immediately when the accident occurs and “on-the-spot” medical attention given if possible. If a doctor cannot come to the scene of the accident immediately, follow his instructions concerning actions to take. Do not add eye drops or other medication unless advised to do so by the doctor. Do not place a battery or acid within the reach of children. If acid (electrolyte) is taken internally drink large quantities of water or milk. Follow with milk of magnesia, beaten egg or vegetable oil. Call a physician immediately.

If electrolyte is spilled or splashed on any surface of the machine, it should be neutralized and rinsed with clean water.

 **CAUTION!** Do not overcharge the battery. Overcharging may reduce the overall service life of the battery.

**CAUTION!** Be sure the battery is fully charged before transporting the sawmill. If the battery is not fully charged, excessive vibration could reduce the overall service life of the battery.

---

<sup>1</sup> Battery Council International, copyright 1987

### Check Machine Before Operation

 **DANGER!** Make sure all guards and covers are in place and secured before operating this machine. Failure to do so may result in serious injury.

 **WARNING!** Always check to ensure the steel fingers inside the sawdust chute are in place before operating this machine. The steel fingers have been designed to help prevent a broken blade or some other object from becoming a projectile and exiting the sawdust chute. Failure to have these fingers in place may result in serious injury.

 **CAUTION!** Be sure the hold-down roller assembly is adjusted to avoid contact with the blade before operating the machine. Failure to do so may result in damage to the machine.



### Keep Persons Away

 **DANGER!** Keep all persons out of the path of moving equipment and lumber when operating this machine. Failure to do so will result in serious injury.

**DANGER!** Always be sure the blade is disengaged and all persons are out of the path of the blade before starting the motor. Failure to do so will result in serious injury.

### Keep Hands Away

 **DANGER!** Always disengage the blade and shut off this machine before changing the blade. Failure to do so will result in serious injury.

**DANGER!** Engine components can become very hot during operation. Avoid contact with any part of a hot engine. The exhaust components of your engine are especially hot during and following operation. Contact with hot engine components can cause serious burns. Therefore, never touch or perform service functions on a hot engine. Allow the engine to cool sufficiently before beginning any service function.



**DANGER!** Always keep hands away from moving bandsaw blade. Failure to do so will result in serious injury.

**DANGER!** Always be aware of and take proper protective measures against rotating shafts, pulleys, fans, etc. Always stay a safe distance from rotating members and make sure that loose clothing or long hair does not engage rotating members resulting in possible injury.

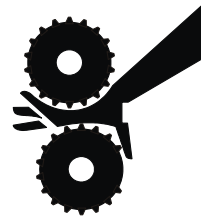

**WARNING!** Always disengage the clutch/brake mechanism whenever the machine is not cutting. Failure to do so may result in serious injury.

**WARNING!** Do not spin the blade wheels by hand. Spinning the blade wheels by hand may result in serious injury.

**WARNING!** Do not for any reason adjust the engine drive belt with the engine running. Doing so may result in serious injury.

**WARNING!** Always keep clear of exiting sawdust. Keep hands, feet and any other objects away from the sawdust chute when operating this machine. Failure to do so may result in serious injury.

### ***Cautions For Gas Or Diesel Engine Operation***



**DANGER!** Operate your engine/machine only in well ventilated areas. The exhaust gases of your engine can cause nausea, delirium and potentially death unless adequate ventilation is present.

**DANGER!** Never operate an engine with a fuel or oil leak. The leaking fuel or oil could potentially come in contact with hot surfaces and ignite into flames.

**WARNING!** Do not operate engine without proper and operational spark arrester/muffler. Sparks emitted from the engine exhaust could ignite surrounding materials, causing serious injury or death.

### Use Proper Maintenance Procedures



**DANGER!** Make sure all electrical installation, service and/or maintenance work is performed by a qualified electrician and is in accordance with applicable electrical codes.

**DANGER!** ARC FLASH AND SHOCK HAZARD! Hazardous voltage inside the electric sawmill disconnect box, starter box, and at the motor can cause shock, burns, or death. Disconnect and lock out power supply before servicing! Keep all electrical component covers closed and securely fastened during mill operation. Wear appropriate Personal Protection Equipment.



**WARNING!** Consider all electrical circuits energized and dangerous.

**WARNING!** Disconnect the negative battery terminal cable before performing any service to the 12-Volt electrical system. Failure to do so may result in injury and/or electrical system damage.

**WARNING!** Never assume or take the word of another person that the power is off; check it out and lock it out.

**WARNING!** Do not wear rings, watches, or other jewelry while working around an open electrical circuit.

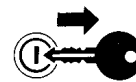

**WARNING!** Before performing service near moving parts such as blades, pulleys, motors, belts and chains, first turn the key switch to the OFF (#0) position and remove the key. If the key is turned on and moving parts activated, serious injury may result.



**WARNING!** Remove the blade before performing any service to the machine. Failure to do so may result in serious injury.

**DANGER!** Lockout procedures must be used during:

- Changing or adjusting blades
- Unjamming operations
- Cleaning
- Mechanical repair
- Electrical maintenance
- Retrieval of tools/parts from work area
- Activities where guards or electrical panel guard is open or

removed

Maintenance hazards include:

- Blade contact
- Pinch points
- Kickbacks
- Missiles (thrown blades/wood chips)
- Electrical

Failure to lockout may result in:

- Cut
- Crush
- Blindness
- Puncture
- Serious injury and death
- Amputation
- Burn
- Shock
- Electrocution

To control maintenance dangers:

Lockout procedures must be followed (see ANSI Standard Z244.1-1982 and OSHA regulation 1910.147).

Never rely on machine stop control for maintenance safety (emergency stops, on/off buttons, interlocks).

Do not reach into moving blades or feed systems. Allow all coasting parts to come to a complete stop.

Electrical power supply and air supply must both be locked out.

Where established lockout procedures cannot be used (electrical troubleshooting or mechanical dynamic troubleshooting), alternative effective protective techniques shall be employed which may require special skills and planning.

Always follow safe operations practices in the workplace.

## **MACHINE LOCKOUT PROCEDURE**

Lockout procedures must be followed (see ANSI Standard Z244.1-1982 and OSHA regulation 1910.147).

### **Purpose:**

This procedure establishes the minimum requirements for lockout of energy sources that could cause injury.

### **Responsibility:**

The responsibility for seeing that this procedure is followed is binding upon all workers. All workers shall be instructed in the safety significance of the lockout procedure. It is your responsibility to ensure safe operation of the machine.

### **Preparation For Lockout:**

Machine must be locked out both electrically and pneumatically (lockout air valve).

### **Sequence of Lockout Procedure:**

1. Notify all persons that a lockout is required and the reason therefore.
2. If the machine is operating, shut it down by the normal stopping procedure.
3. Operate the switch and valve so that the energy sources are disconnected or isolated from the machine. Stored energy such as moving blades, feed system and air pressure shall be dissipated.
4. Lockout the energy isolating devices with assigned individual locks.
5. After ensuring that no persons are exposed and as a check on having disconnected the energy sources, operate the push button or other normal operating controls to make certain the machine will not operate. Caution: Return operating controls to neutral position after the test.
6. The machine is now locked out.



### Restoring Equipment to Service

1. When the job is complete and the machine is ready for testing or normal service, check the area to see that no one is exposed.
2. When the machine is all clear, remove all locks. The energy isolating devices may be operated to restore energy to the machine.

### Procedure Involving More Than One Person

In the preceding steps, if more than one individual is required to lock out the machine, each shall place his own personal lock on the energy isolating devices.

### Rules for Using Lockout Procedure

The machine shall be locked out to protect against accidental or inadvertent operation when such operation could cause injury to personnel. Do not attempt to operate any switch or valve bearing a lock.

### Owner's Responsibility

The procedures listed in this manual may not include all ANSI, OSHA, or locally required safety procedures. It is the owner/operator's responsibility and not Wood-Mizer to ensure all operators are properly trained and informed of all safety protocols. Owner/Operators are responsible for following all safety procedures when operating and performing maintenance to the machine.

### Keep Safety Labels In Good Condition



**IMPORTANT!** Always be sure that all safety decals are clean and readable. Replace all damaged safety decals to prevent personal injury or damage to the equipment. Contact your local distributor, or call your Customer Service Representative to order more decals.

**IMPORTANT!** If replacing a component which has a safety decal affixed to it, make sure the new component also has the safety decal affixed.

## SECTION 2 INTRODUCTION

### 2.1 Getting Service

Wood-Mizer is committed to providing you with the latest technology, best quality and strongest customer service available on the market today. We continually evaluate our customers' needs to ensure we're meeting current wood-processing demands. Your comments and suggestions are welcome.

#### *General Contact Information*

Toll free phone numbers are listed below for the *continental* U.S. and Canada. See the next page for contact information for specific Wood-Mizer locations.

	<b>United States</b>	<b>Canada</b>
<b>Sales</b>	1-800-553-0182	1-877-866-0667
<b>Service</b>	1-800-525-8100	1-877-866-0667
<b>Website</b>	www.woodmizer.com	www.woodmizer.ca
<b>E-mail</b>	woodmizer@woodmizer.com	oninfo@woodmizer.com

**Office Hours:** All times are Eastern Standard Time.

<b>Monday - Friday</b>	<b>Saturday (Indianapolis Office Only)</b>	<b>Sunday</b>
8 a.m. to 5 p.m.	8 a.m. to 12 p.m.	Closed

Please have your vehicle identification number and your customer number ready when you call.

Wood-Mizer will accept these methods of payment:

- Visa, Mastercard, or Discover
- COD
- Prepayment
- Net 15 (with approved credit)

Be aware that shipping and handling charges may apply. Handling charges are based on size and quantity of order. In most cases, items will ship on the day they are ordered. Second Day and Next Day shipping are available at additional cost.

If your sawmill was purchased outside the United States or Canada, contact the distributor for service.

## **Wood-Mizer Locations**

### **USA World Headquarters**

*Serving North & South America, Oceania, East Asia*

Wood-Mizer LLC  
8180 West 10th Street  
Indianapolis, IN 46214

Phone: 317.271.1542 or 800.553.0182  
Customer Service: 800.525.8100  
Fax: 317.273.1011  
Email: [infocenter@woodmizer.com](mailto:infocenter@woodmizer.com)

### **Canadian Headquarters**

*Serving Canada*

Wood-Mizer Canada  
396 County Road 36, Unit B  
Lindsay, ON K9V 4R3

Phone: 705.878.5255 or 877.357.3373  
Fax: 705.878.5355  
Email: [ContactCanada@woodmizer.com](mailto:ContactCanada@woodmizer.com)

### **Brazil Headquarters**

*Serving Brazil*

Wood-Mizer do Brasil  
Rua Dom Pedro 1, No: 205 Bairro: Sao Jose  
Ivoti/RS CEP:93.900-000

Tel: +55 51 9894-6461/ +55 21 8030-3338/ +55 51  
3563-4784  
Email: [info@woodmizer.com.br](mailto:info@woodmizer.com.br)

### **Europe Headquarters**

*Serving Europe, Africa, West Asia*

Wood-Mizer Industries Sp z o.o.  
Nagorna 114  
62-600 Kolo, Poland

Phone: +48.63.26.26.000  
Fax: +48.63.27.22.327

### **Branches & Authorized Sales Centers**

For a complete list of dealers, visit [www.woodmizer.com](http://www.woodmizer.com)

## 2.2 Specifications

### Model: HR120 Rev. A1.00+

#### Machine Dimensions:

Length: 76 3/4"  
 Width (Max Blade Guide Arm Position): 81 9/64"  
 Height (Max Saw Head Position): 86 7/64"  
 Table Height: 37"

	G15	G25	D17	E10
Weight (Basic Unit):	980 lbs	1012 lbs	965 lbs	1000 lbs

#### Material Dimensions:

Minimum Cut Height: 1/4"  
 Maximum Cut Height: 10 1/4"  
 Maximum Material Height: 12"  
 Minimum Material Length: 18"  
 Maximum Material Length: Unlimited  
 Minimum Material Width: 1"  
 Maximum Material Width: 16"

#### Feed System:

Feed Rate: 0-60 Ft/Min  
 Feed Motor: 1/5HP 33:1 12VDC

#### Blade:

Length: 158"  
 Standard Width: 1 1/4"  
 Optional Width: 1 1/2"  
 Profile: Many types available depending upon cutting needs

#### Blade Motor:

	G15	G25	D17	E10
Manufacturer:	Kohler	Kohler	Kohler	Lincoln
Fuel:	Gas	Gas	Diesel	Electric
Horsepower Rating:	15	25	16.8	10
Weight:	119 lbs	151 lbs	104 lbs	139 lbs
Idle Speed:	1800 RPM	1800 RPM		3495 RPM
High Throttle Speed (No Load):	3750 RPM	3600 RPM		3495 RPM
Noise Level - @ operator position:	96 dBA	102 dBA		
Noise Level - 20 feet away:	86 dBA	94 dBA		
Blade Speed (No Load):	4940 sfpm			
Fuel Consumption (per hour):	0.5 gal.	0.9 gal.		
Cooling System:	Air	Air	Water	Air
Drive Shaft O.D.:	1"	1 1/8"	1 9/16"	1 3/8"
Drive Pulley O.D.:	5"	5.6"	5.6"	4.25"
Drive Belt:	BX87	2/3VFL900	2/3VFL900	BX85
Blade Braking:	5 Seconds	5 Seconds	5 Seconds	5 Seconds
Oil Capacity w/Filter:	2 qts.	2.1 qts.	1.7 qts.	N/A
Battery:	12V 524/26A	12V 524/26A	12V 524/26A	N/A



# 2

## Introduction Specifications

Battery Specifications							
Group No.	Type No.	Performance Level		Approximate Weight	Maximum Overall Dimensions		
		Cranking Performance	Reserve Capacity	Wet	Length	Width	Height
26	524/26A	515CC	80	31.0 lb. (14.06 kg)	8.5 in. (216 mm)	6.75 in. (171 mm)	8.0 in. (203 mm)

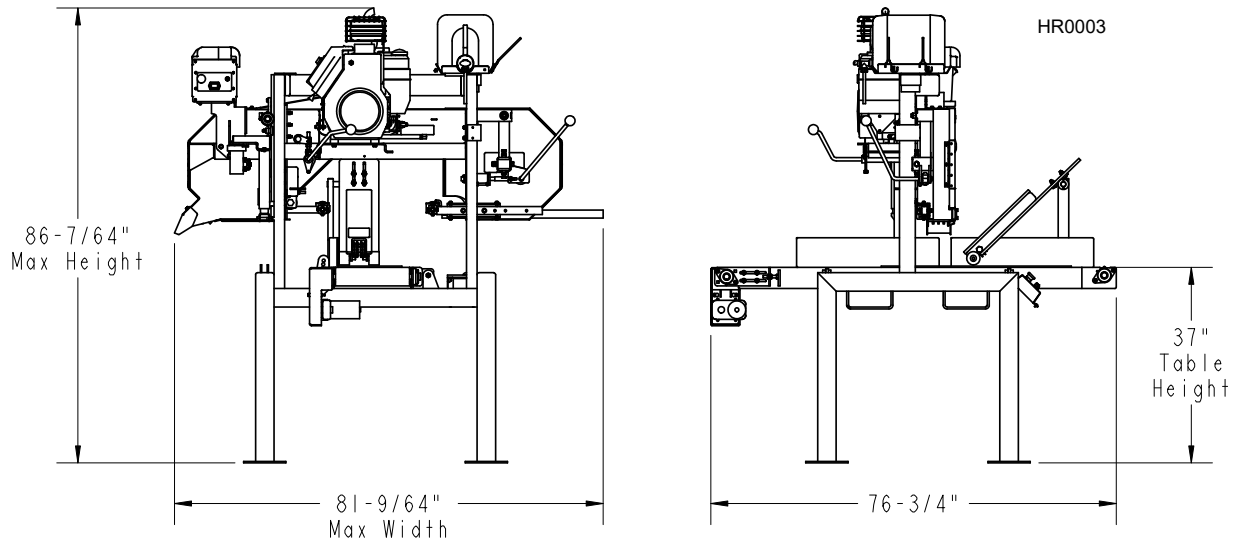

## 2.3 Customer and Machine Identification

Each HR100 Series Resaw is identified with a model number, revision, and serial number (see the figure below).

MFG BY/ FABRIQUÉ PAR: WOOD-MIZER PRODUCTS, INC. 8180 W. 10th St. Indianapolis, IN 46214-2400 U.S.A. 317/ 271-1542 Or 800/ 553-0182	
<b>Model No.:</b>	HR120 G15 -1
<b>Serial No.:</b>	09090001
<b>Rev.:</b>	A1.00

HR0001B

### SERIAL NUMBER TAG.

The model number includes the base model and the engine/motor configuration. The serial number contains the month and year of manufacture and a sequence number. The revision number helps identify the exact design of the equipment. See the figure for a description of the model, serial, and revision numbers.

Model Number	<b>HR120</b> Basic Machine I.D.	<b>G18</b> Engine/Motor Configuration	<b>A</b> Voltage Config. (Electric Only)	<b>-1</b> # Heads
Serial Number	<b>0909</b> Month/Year of Manufacture	<b>0001</b> Manufacture Sequence		
Revision Number	<b>A1.</b> Major Revision Code	<b>00</b> Minor Revision Code		

### MODEL, SERIAL, AND REVISION NUMBER DESCRIPTION.

## **2** Introduction

*Customer and Machine Identification*

---

The serial number tag can be found at the following location.

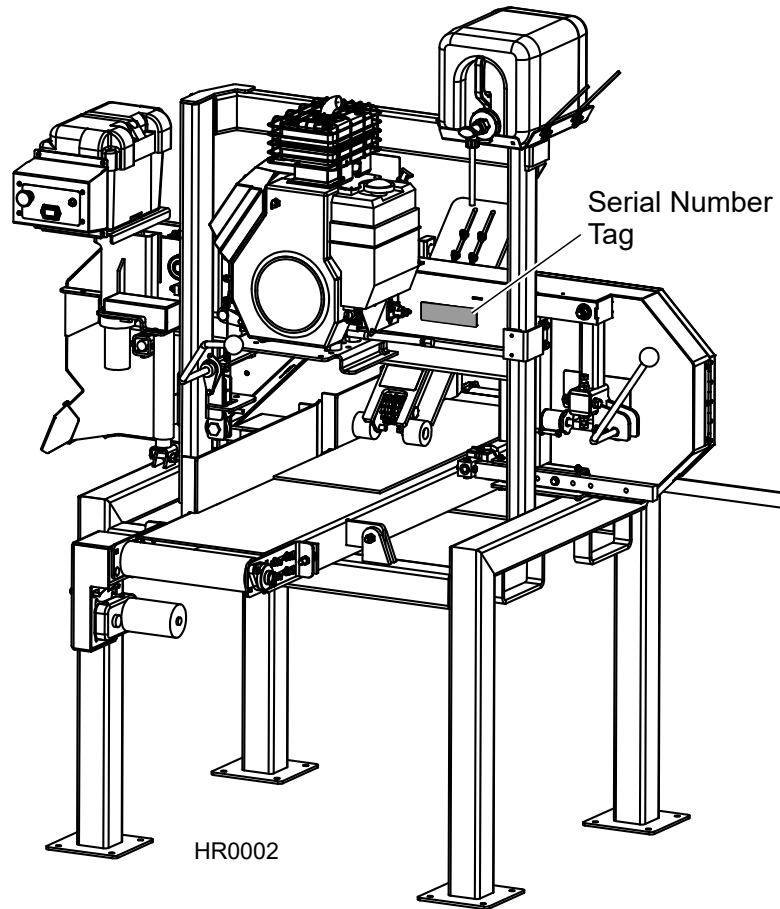

**SERIAL NUMBER TAG LOCATION.**



## SECTION 3 SETUP

### 3.1 Resaw Setup

Use a forklift or other appropriate equipment to move the resaw.

**WARNING!** Use extreme care and proper equipment to lift and move the machine. Lift the machine from sides equipped with fork pockets only, never from under the front or rear of the base or upper saw head. Failure to do so may result in personal injury and/or machine damage.

See Figure 3-1.

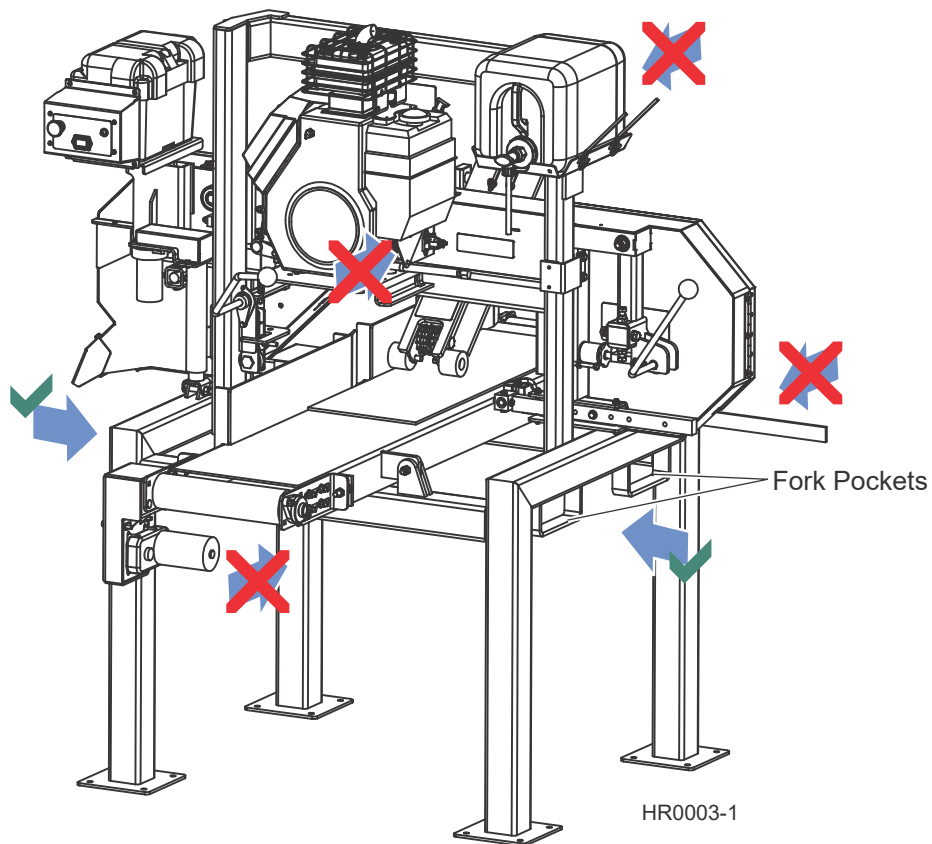



**FIG. 3-1**

Place the resaw on a concrete foundation strong enough to support the weight of the machine. Allow for room around the resaw to feed and remove material. Secure the resaw to the foundation with anchor bolts.

### 3.2 Electrical Installation (HR120 E10/HR130 E15 Only)

 **DANGER!** Make sure all electrical installation, service and/or maintenance work is performed by a qualified electrician and is in accordance with applicable electrical codes.

 **CAUTION!** Make sure that the machine you have purchased can be powered with the provided power source before making any connections. Do not connect the machine to the improper power source. Serious injury, death or damage to the equipment will result.

 **Have a qualified electrician install the power supply before receipt of your resaw.** The power supply must meet the enclosed specifications concerning wire size, fused disconnect, and voltage. The electrical installation must also meet local codes.

**Have a qualified electrician present when the resaw is to be installed.** All relevant motor specifications and wiring information are provided. When scheduling an electrician for the day of installation, please confirm that they have enough of the proper size cable (wiring). Many electricians may not stock this cable, which could seriously delay installation and training.

**See Table 3-1.** All electrical installation must meet local electrical codes. Install a fused disconnect switch within sight of the machine. The disconnect must be equipped with Class J fuses. Fuse size will be determined by the conductor wire size, but must be at least as large as the full-load amperage (FLA) of the machine (see electrical information below). Fuses supplied in the resaw electrical control are sized for short-circuit protection only. The motor is configured with internal thermostats overload protection. If an overload condition does occur, the thermostats shut the motor down and the motor cannot be restarted until it cools to a safe operating temperature.

Model	FLA of Largest Load	FLA	IR (AIC)	SCCR	Volts	Hz	PH	Transformers required to convert resaw to			
								240V	400V	480V	600V
HR120EA10	41.5A	67A	300kA	50kA	240V	60	1	N/A	N/A	N/A	N/A
HR130EB15	35	40.4A	200kA	1kA	240V	60	3	X	078212	X	078213
HR130EC15	17.5	22A	200kA	1kA	480V	60	3	X	069616	X	068047

**TABLE 3-1**

**See Figure 3-2.** Route the incoming power supply to the main electrical control cabinet. Punch a knockout in the box and route the cable through the box and secure the cable properly. Connect to cable wires to the power disconnect in the upper-right corner of the cabinet. Connect the ground wire to a panel mount stud.

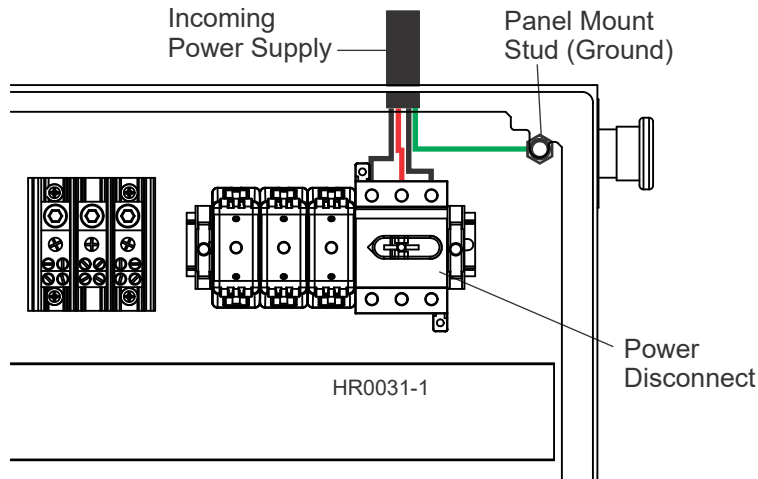

**FIG. 3-2**

**See Table 3-2.** This table lists the specifications for the resaw blade motor.

<b>Electric Blade Motor Specifications</b>	<b>HR120EA10</b>	<b>HR130EB15</b>	<b>HR130EC15</b>
<b>Horsepower</b>	10	15	15
<b>RPM</b>	3500	3500	3500
<b>Volts</b>	230	230	460
<b>Full-Load Amps</b>	41.5	35	17.5
<b>SF</b>	1.0	1.0	1.0
<b>NOM EFF</b>	85.5	85.5	85.5
<b>Frame</b>	215T	215T	215T
<b>Design</b>	L	L	L
<b>AMB</b>	40° C	40° C	40° C
<b>INS</b>	F3	F3	F3
<b>PH</b>	1	3	3
<b>ENCL</b>	TEFC	TEFC	TEFC
<b>Code</b>	G	G	G
<b>Duty</b>	Saw	Saw	Saw

**TABLE 3-2**

## **3** Setup *Upper Hold-Down Adjustment*

### **3.3 Upper Hold-Down Adjustment**



**CAUTION!** Be sure the hold-down roller assembly is adjusted to avoid contact with the blade before operating the machine. Failure to do so may result in damage to the machine.

**See Figure 3-3.** Loosen the four hold-down adjustment bolts and move the hold-down roller in or out as desired. Adjust the hold-down roller to secure material as close to the blade as possible without interfering with the blade. This adjustment will vary depending on the height of the blade and the material being processed.

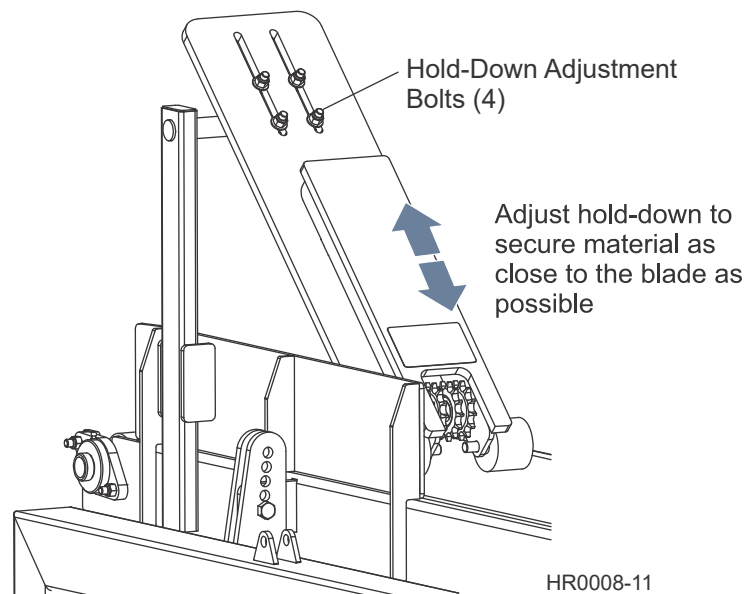
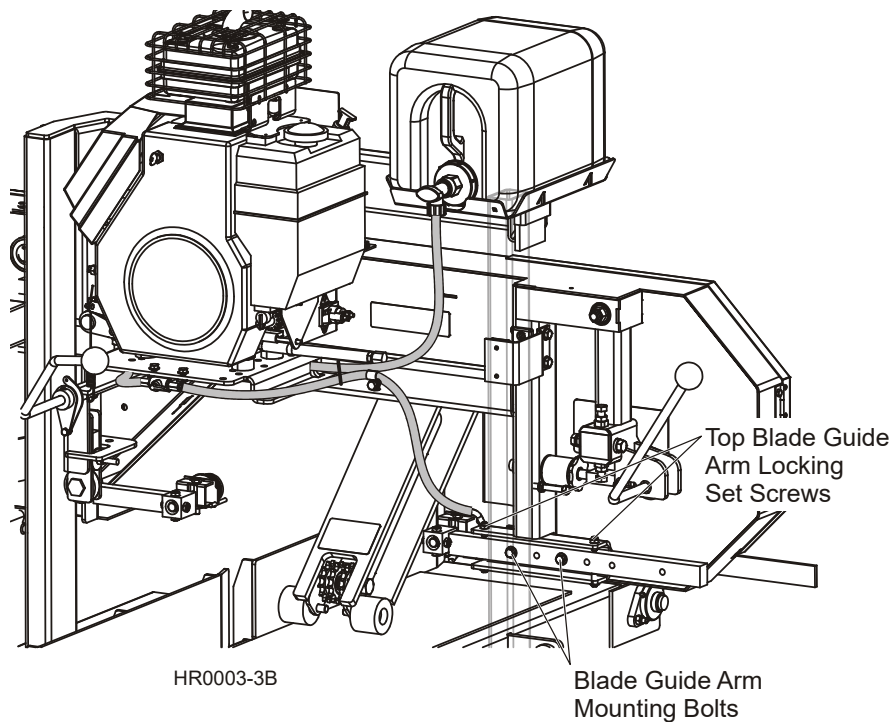

**FIG. 3-3**

### 3.4 Blade Guide Arm Adjustment

The outside blade guide arm can be relocated to position the outer blade guide relative to the material to be sawn. In general, the outer guide should be positioned as close to the material as possible.

**See Figure 3-4.** To relocate the outer blade guide arm, remove the two arm mounting bolts and hardware. Loosen the two top arm locking set screws and move the arm in or out to align the mounting holes. Retighten the top locking set screws and replace the mounting bolts and hardware.



**FIG. 3-4**

### 3.5 Conveyor Tilt Adjustment

The conveyor table can be tilted to allow cutting of tapered lap siding. To tilt the conveyor, remove the tilt adjustment bolts. Lift the conveyor table to align the desired bracket holes. Each hole increases the tilt 2 degrees. Replace the tilt adjustment bolts and tighten the nuts to secure the conveyor table at the desired tilt setting.

See Figure 3-5.

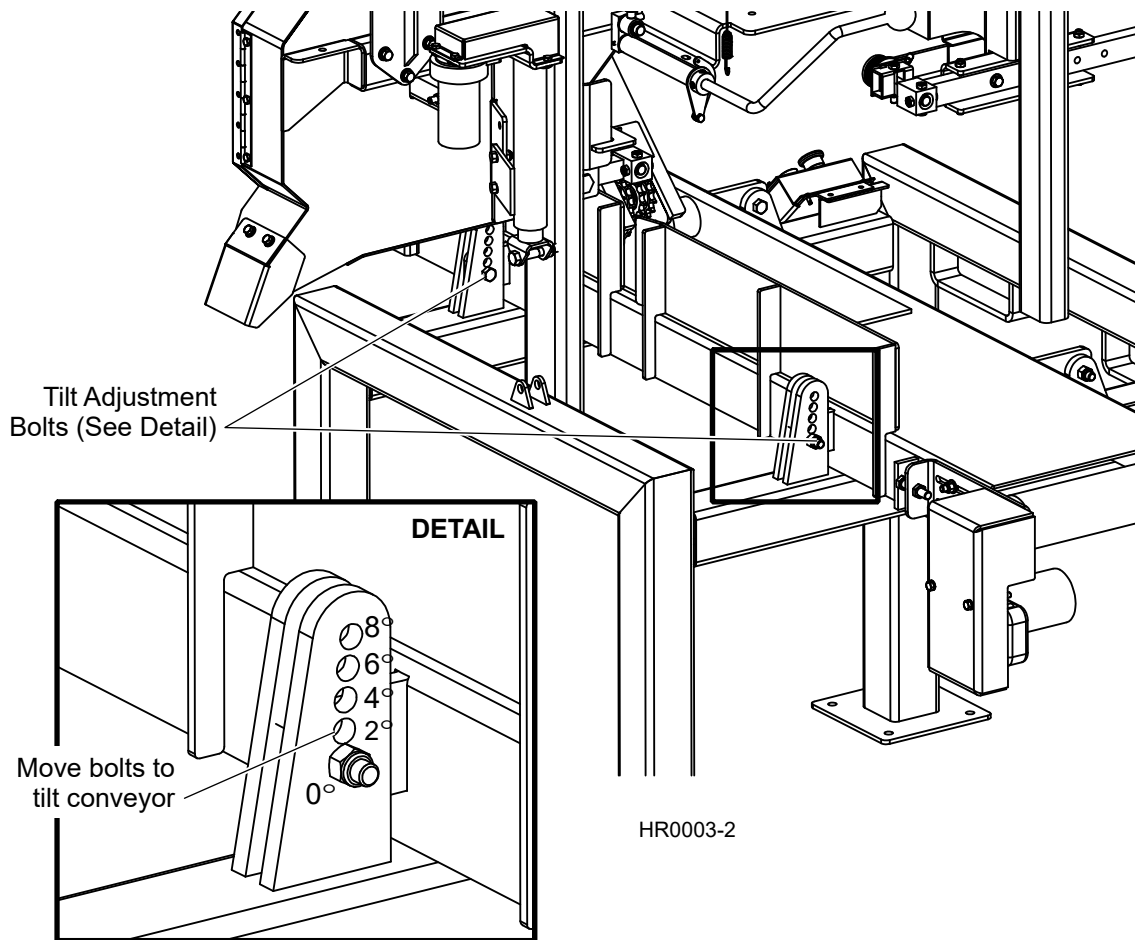

FIG. 3-5

**NOTE:** If equipped with the optional conveyor tables, loosen the end table mount bolts and tilt the tables to align with the conveyor ([See Section 3.10](#)). Retighten the mount bolts.

### 3.6 Shingle Belt Installation (Optional)

1. Turn the resaw power on and use the feed rate switch to start the resaw conveyor belt. Stop the belt when the belt seam is on top and easily accessible. Push the emergency stop to turn resaw power off.
2. Loosen the belt tensioners on each side of the resaw frame and push the belt roller in to provide slack in the conveyor belt.
3. Remove the seam wire to separate the belt at the seam and remove the conveyor belt from the resaw.
4. Place the shingle belt on the resaw frame and secure the seam with the seam wire. Adjust the belt tensioners on each side of the resaw frame to tension the shingle belt.
5. Lift the hold-down roller arm and install the shingle stop assembly to the resaw frame side plate just in front of the blade. Tighten the clamping bolts to secure the stop assembly to the resaw.

See Figure 3-6.

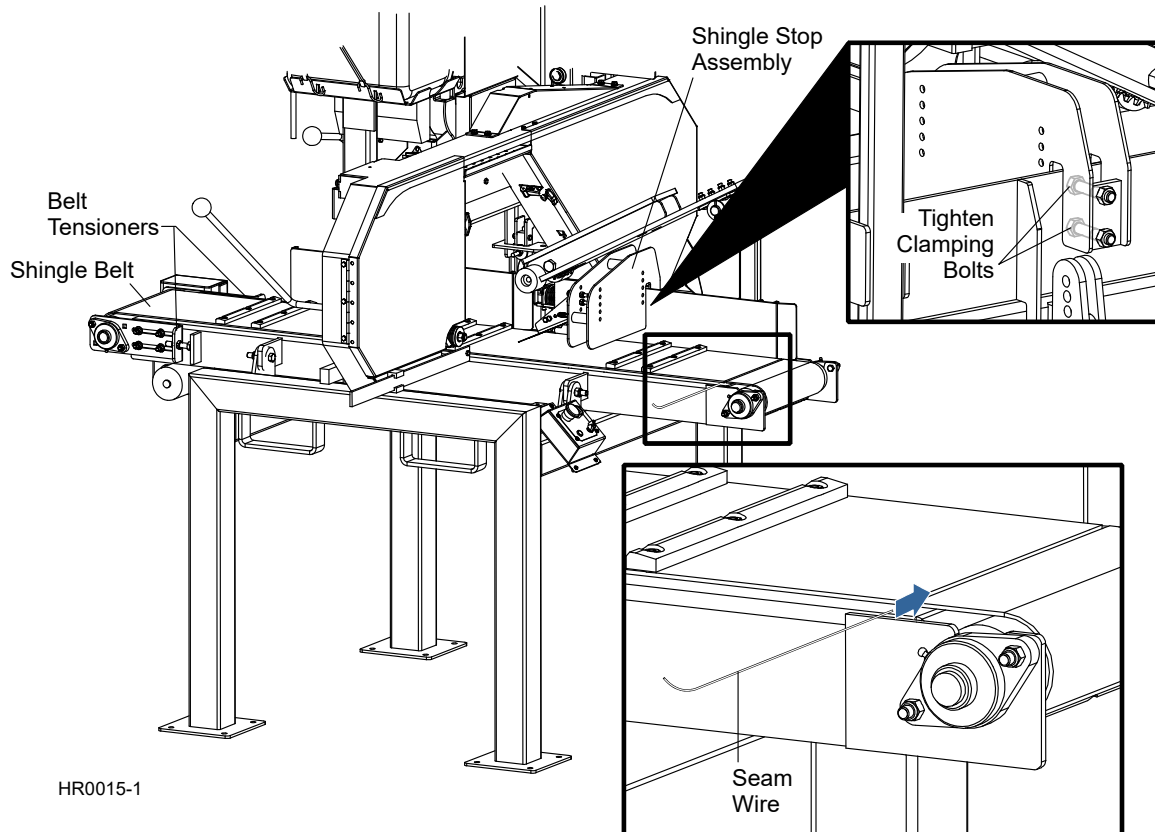

**FIG. 3-6**

### 3.7 Tensioning The Blade

The blade tensioner is factory-set so proper blade tension is achieved when the rubber spring is compressed 3/16" (4.8 mm). An indicator bolt is provided to indicate when the rubber spring has been compressed properly. To tension the blade, turn the blade tension handle up until it locks in place.



**WARNING!** Use both hands to operate the blade tensioner handle. Failure to do so may result in injury.

Check the back side of the rubber spring washer is aligned with the indicator bolt head. If not, release the blade tension and turn the tensioner shaft counterclockwise to compress the rubber spring more; clockwise to compress the rubber spring less.

See **Figure 3-7**. Use the scalloped disk to turn the tensioner shaft.

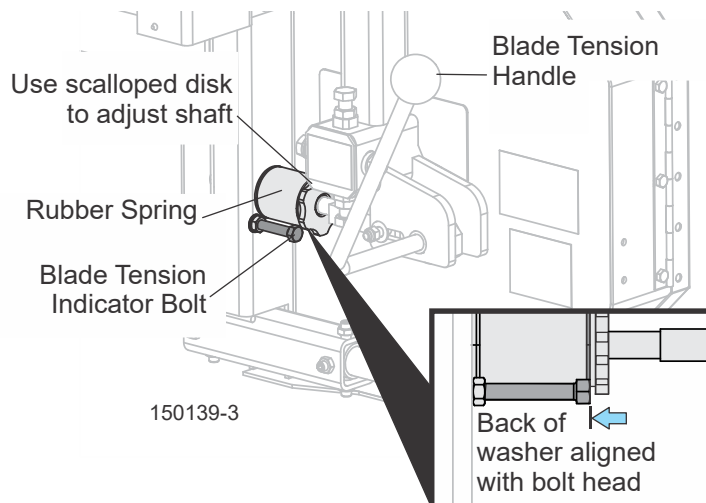

**FIG. 3-7**

Tension the blade and recheck the alignment of the rubber spring washer with the indicator bolt head.

Check the blade tension occasionally when adjusting the cant control or while cutting. As the blade and belts heat up and stretch, the blade tension will change. Adjust the tensioner shaft as necessary to maintain proper blade tension.



### 3.8 Replacing The Blade



**DANGER!** Always disengage the blade and shut off the resaw motor before changing the blade. Failure to do so will result in serious injury.



**WARNING!** Always wear gloves and eye protection when handling bandsaw blades. Changing blades is safest when done by one person! Keep all other persons away from area when coiling, carrying or changing a blade. Failure to do so may result in serious injury.

Open the two blade housing covers that cover the blade wheels. Turn the blade tension handle to release the blade tension until the wheel is pulled in and the blade is lying loose in the blade housing. Lift the blade out of the blade housing.

When installing a blade, make sure the teeth are pointing the correct direction. The teeth should be pointing toward the infeed and sawdust chute sides of the resaw. Install the blade so it is lying around the wheels.

Position 1 1/4" wide blades on the wheels so the gullet is 1/8" (3.0 mm) out from the edge of the wheel. Position 1 1/2" wide blades on the wheels so the gullet is 3/16" (4.5 mm) out from the edge of the wheel.

Close the blade housing cover.

Next, turn the tension handle until the blade is tensioned correctly.

### 3.9 Tracking The Blade

1. Make sure the blade housing covers are closed and all persons are clear of the open side of the saw head.
2. Start the motor, rotating the blade until the blade positions itself on the wheels.

 **WARNING!** Do not spin the blade wheels by hand. Spinning the blade wheels by hand may result in serious injury.

3. Turn off the motor, open the blade housing covers and check the position of the blade on the blade wheels.

**See Figure 3-8.** Position 1 1/4" wide blades so the gullet is 1/8" (3.0 mm) out from the edge of the blade wheel ( $\pm 1/16$  [1.5 mm])( $\pm 1/32$  [.75 mm]).

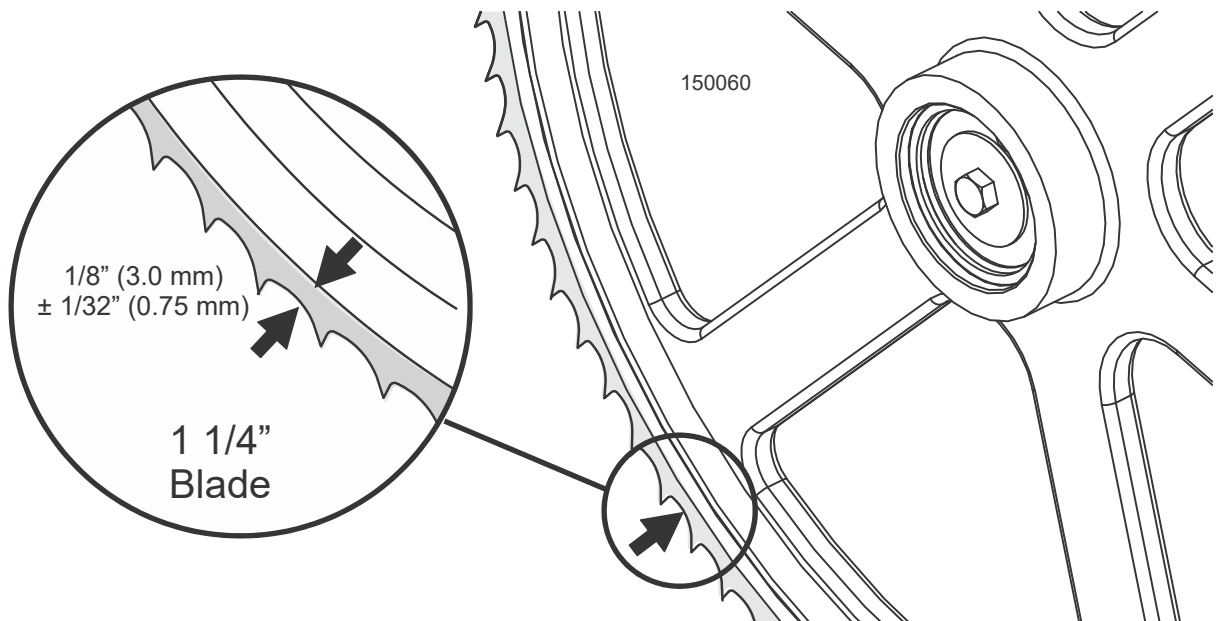

**FIG. 3-8**

See **Figure 3-9**. To adjust where the blade travels on the blade wheels, use the cant control.

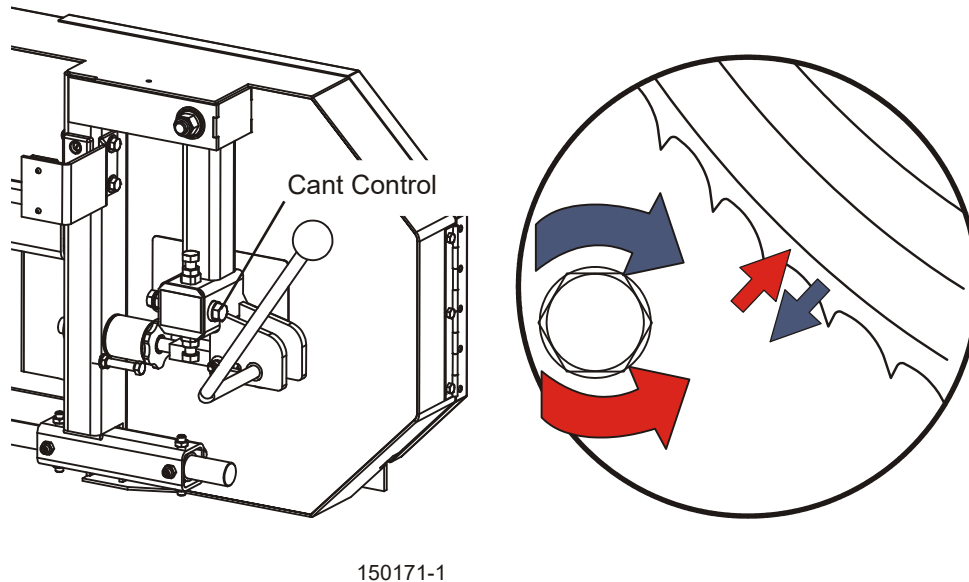

**FIG. 3-9**

If the blade is too far out, back the blade onto the wheel by turning the cant control counterclockwise. If the blade is too far in, turn the cant control clockwise until the gullet of the blade is the correct distance from the front edge of the wheel.

4. Adjust the blade tension if necessary to compensate for any changes that may have occurred while adjusting the cant control.
5. Close the blade housing covers.

**⚠ DANGER!** Make sure all guards and covers are in place and secured before operating the resaw. Failure to do so may result in serious injury. Be sure the blade housing and pulley covers are in place and secure.

**⚠ IMPORTANT!** After aligning the blade on the wheels, always double-check the blade guide spacing and location. ([See page 6-17](#) for more information.)

### 3.10 Table Setup (Optional)

Optional conveyor tables are available to handle material to improve productivity. The tables allow operators to stage material on the infeed and outfeed ends of the resaw. A table mounted to the side of the resaw allows the return of material to be refed into the resaw.

**See Table 3-3.** The table components are available in modules so the customer can configure the setup most ideal for their operation:

Part No.	Description	Comments
HRTBL-KIT	Table Kit, Complete HR	Includes two end tables, mounting brackets and a side table
HRTBL-END1	Table Assembly, HR End	4' infeed/outfeed table. Multiple tables can be connected end-to-end for longer configurations
HRTBL-MOUNT	Mount Assembly, HR Table	Includes brackets to mount tables to the HR100 Series Resaw
HRTBL-SIDE	Table Assembly, HR Side	Return table mounts to side of HR100 Series Resaw
HRTBL-END2	Table Assembly, HR Stand-Alone	Free-standing 4' conveyor table

**TABLE 3-3**

See Figure 3-10. An overview of the table configuration is provided below.

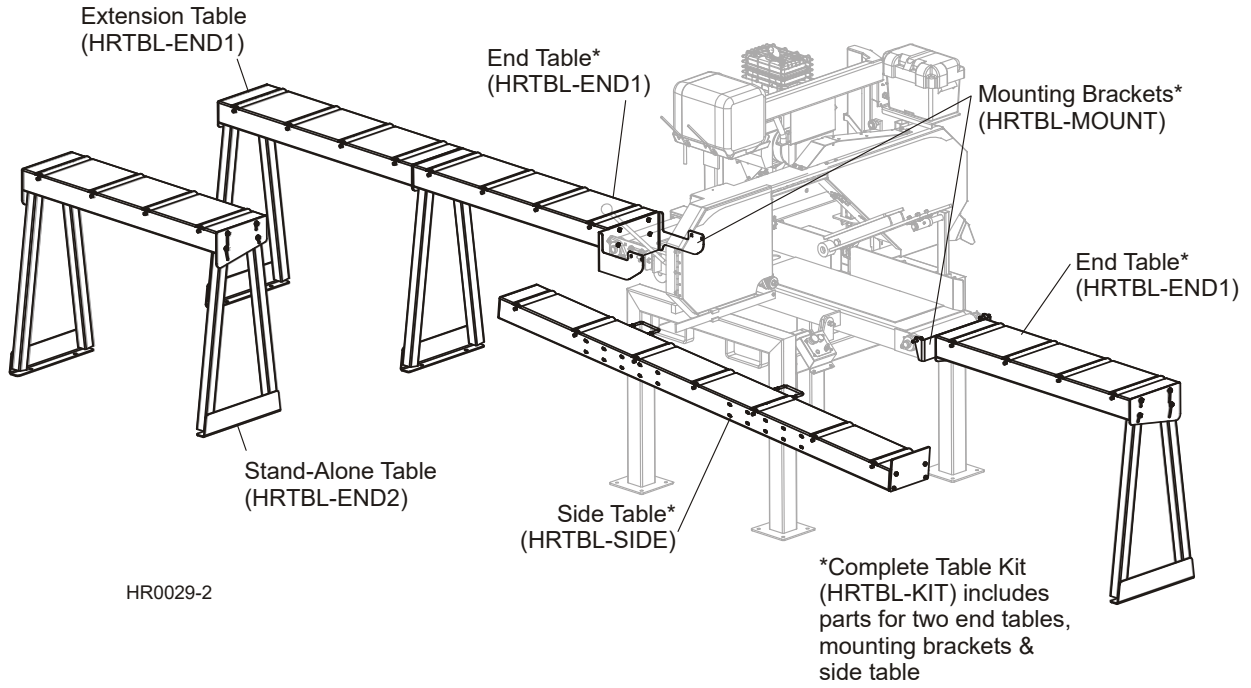

**FIG. 3-10**

### 3 Setup

#### Table Setup (Optional)

See Figure 3-11. At the resaw conveyor, remove the two top conveyor belt bearing mount bolts and lock nuts. Install the front mount plate to the resaw conveyor and secure the mount plate with the provided 3/9-16 x 2" hex head bolts and the original lock nuts.

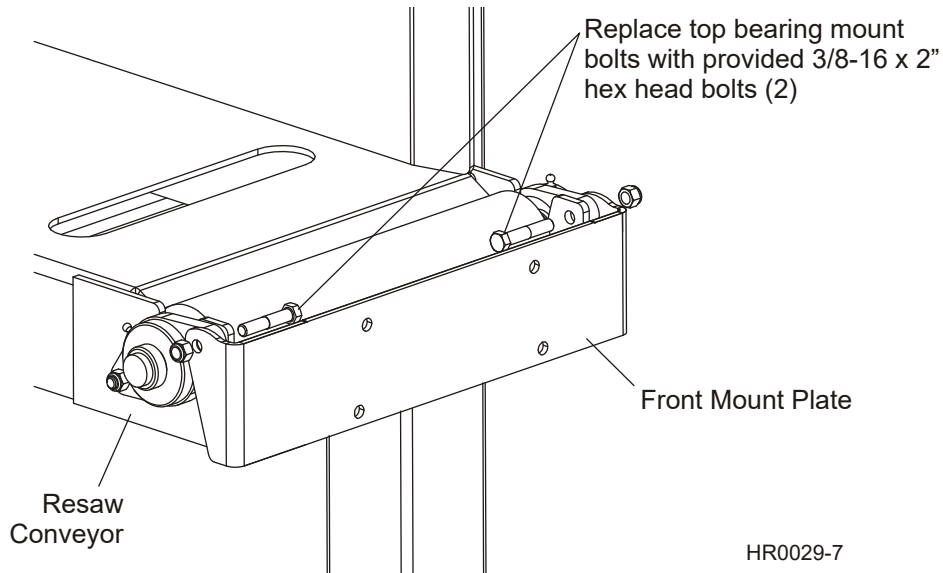

FIG. 3-11

See Figure 3-12. Place the end table assembly in position to align the end table holes with the mounting plate holes. Use the provided 3/8-16 x 1" bolts, flat washers and lock nuts to secure the end table to the mount plate.

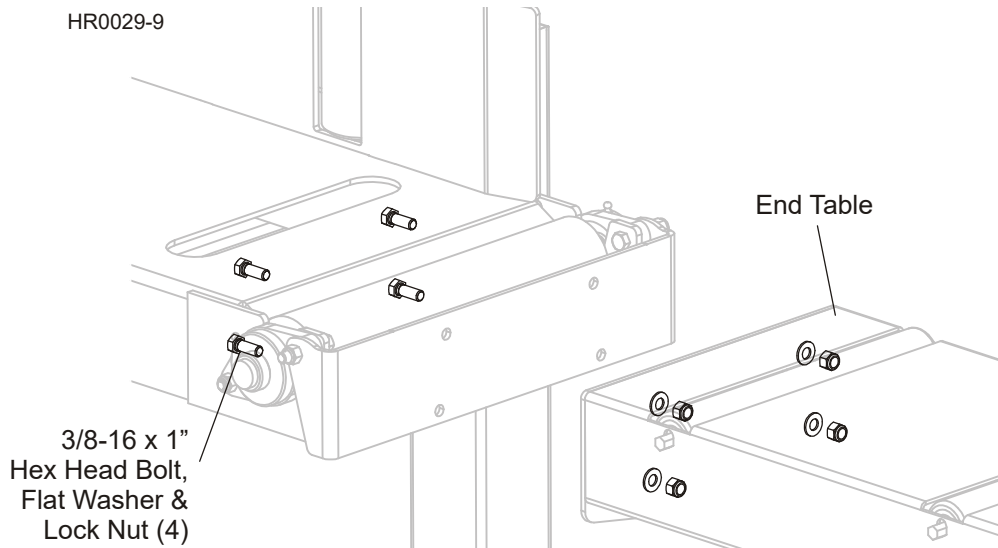
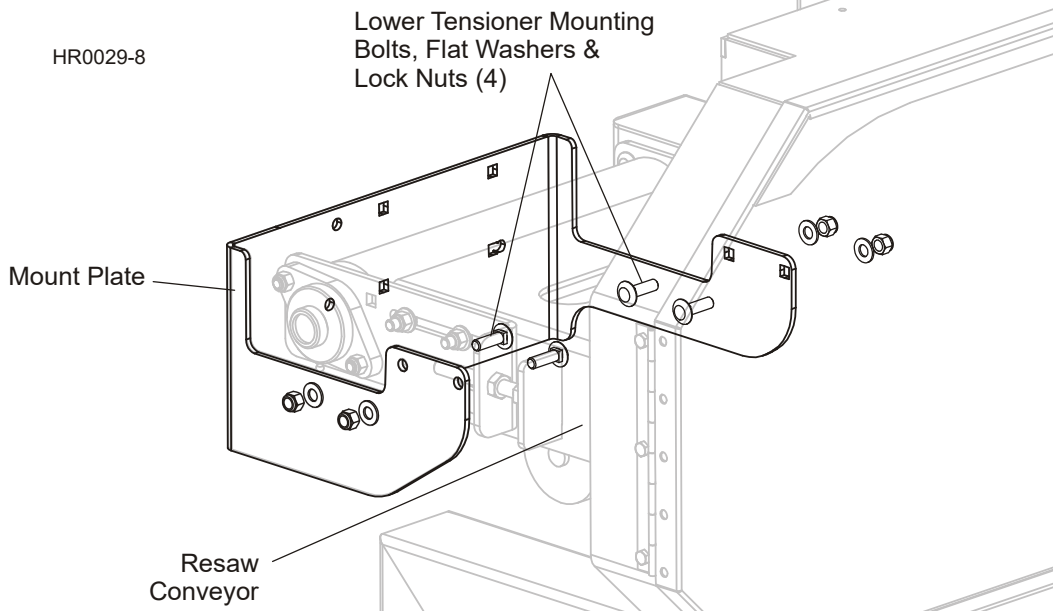

FIG. 3-12

**See Figure 3-13.** At the other end of the resaw conveyor, remove the four bottom belt tensioner mount bolts, flat washers and lock nuts. Install the provided rear mount plate to the resaw conveyor and replace the original hex head bolts, flat washers and lock nuts.



**FIG. 3-13**

**See Figure 3-14.** Place the end table assembly in position to align the end table holes with the mounting plate holes. Use the provided 3/8-16 x 1" bolts, flat washers and lock nuts to secure the end table to the mount plate.

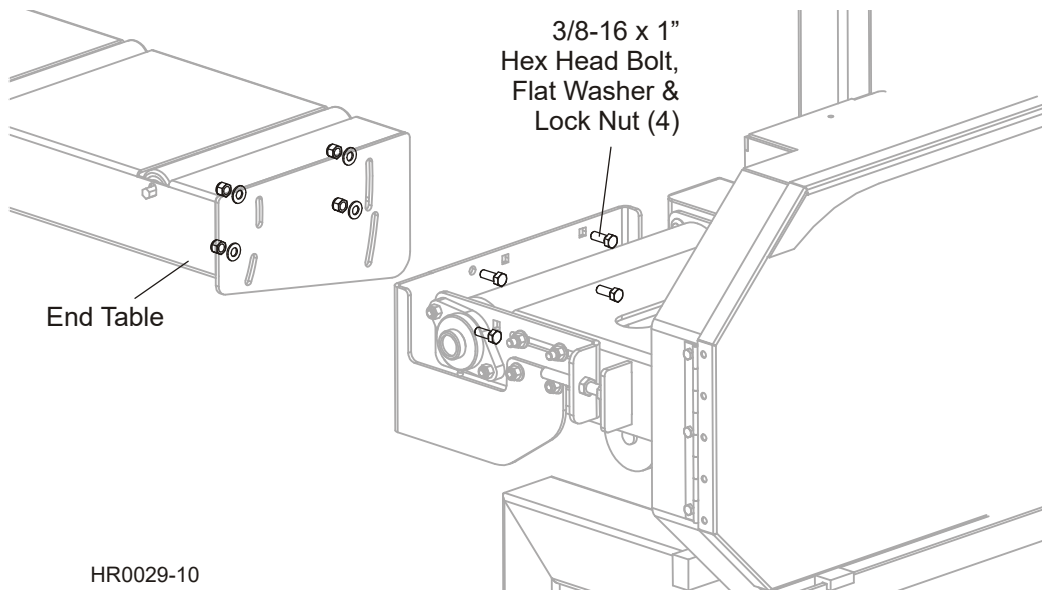

**FIG. 3-14**

# 3

## Setup

### Table Setup (Optional)

See **Figure 3-15**. Install the stop end plate to the side table with four 3/8-16 x 1" hex head bolts, flat washers and lock nuts. Assemble the side table to the resaw legs with the four provided U-bolts, flat washers and lock nuts. Mount the side table so it tilts down from front to back, so material will roll toward the infeed end of the resaw.

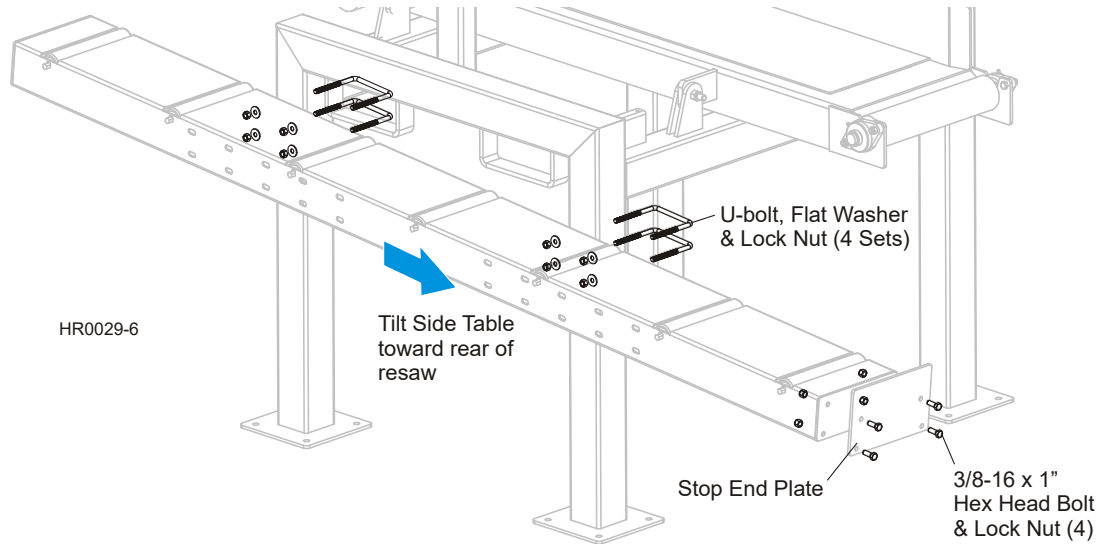

**FIG. 3-15**

If operating the resaw with the conveyor tilted for siding, loosen the end table mount bracket bolts and tilt the tables to align with the conveyor. Retighten the mount bolts.



## SECTION 4 OPERATION

### 4.1 Up/Down Operation

1. If necessary, release the emergency stop buttons (⊙) on all controls. Release the stop by turning it clockwise until it pops out.
2. Turn the feed rate switch (←) counterclockwise to its lowest setting.
3. To turn the resaw power on, push the green (⏻) button on the operator control box. The green power light (⏻) will illuminate when the power is on.

See Figure 4-1.

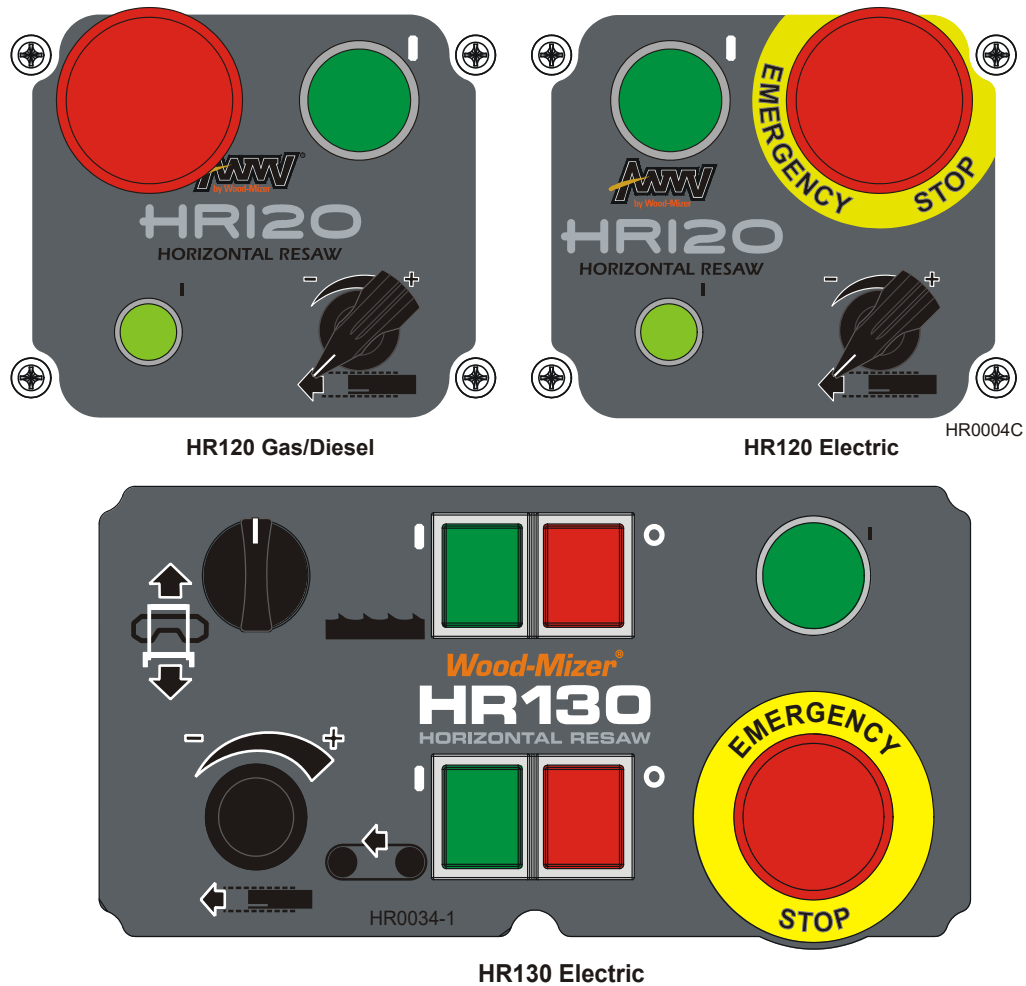



FIG. 4-1

## 4 Operation

### Up/Down Operation

4. Hold the up/down (  ) toggle switch up (HR120) or rotate the selector switch to the right (HR130) to raise the saw head. Hold the toggle switch down (HR120) or rotate the selector switch to the left (HR130) to lower the saw head. Raise or lower the saw head until the blade is positioned the desired distance above the conveyor belt.

See Figure 4-2.

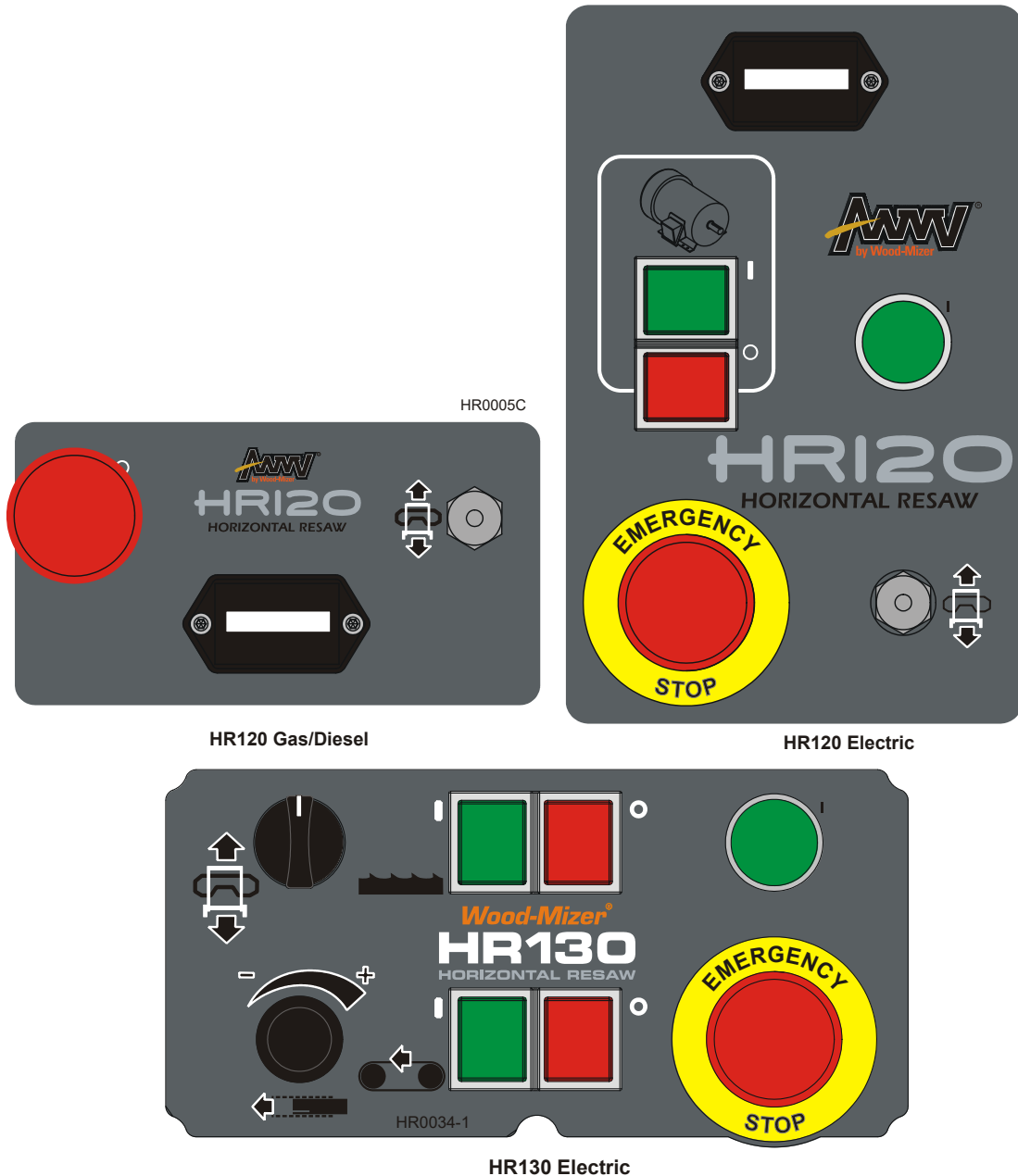

FIG. 4-2

- 5. Use the blade height indicator and scale to determine the height of the blade above the feed conveyor.

See Figure 4-3.

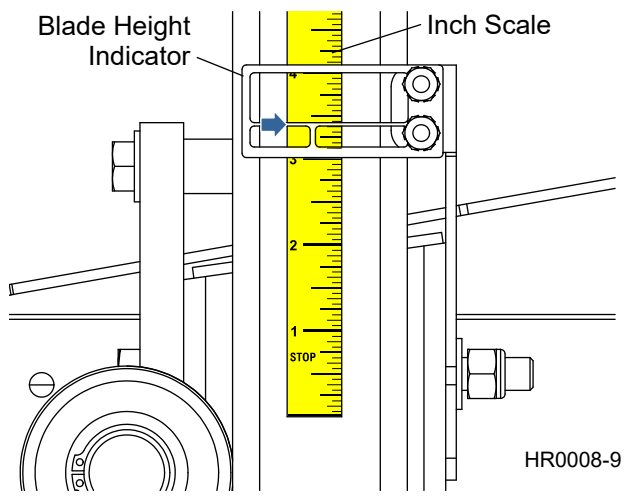

FIG. 4-3

## 4.2 Machine Start



**DANGER!** Always be sure the blade is disengaged and all persons are out of the path of the blade before starting the engine/motor. Failure to do so will result in serious injury.

1. Clear any loose objects from the area of the blade, engine/motor, and drive belt.
2. Be sure the blade housing and pulley covers are in place and secure before starting the engine. Use the rubber latches to fasten the blade housing covers shut.

### *Gas Models*



**DANGER!** Operate your engine/machine only in well ventilated areas. The exhaust gases of your engine can cause nausea, delirium and potentially death unless adequate ventilation is present.

**DANGER!** Never operate an engine with a fuel or oil leak. The leaking fuel or oil could potentially come in contact with hot surfaces and ignite into flames.



**WARNING!** Do not operate engine without proper and operational spark arrester/muffler. Sparks emitted from the engine exhaust could ignite surrounding materials, causing serious injury or death.

3. Close the engine choke by moving the choke lever to the start position.
4. Turn the key switch to the START position and release. Release the key switch to the RUN position after the engine starts.
5. When the engine starts, slowly open the choke all the way by moving the choke lever to the off position.
6. To turn off the engine, let the engine run for 15 seconds with no load, then turn the key switch to the OFF position.

### **Diesel Models**



**DANGER!** Operate your engine/machine only in well ventilated areas. The exhaust gases of your engine can cause nausea, delirium and potentially death unless adequate ventilation is present.

**DANGER!** Never operate an engine with a fuel or oil leak. The leaking fuel or oil could potentially come in contact with hot surfaces and ignite into flames.







**WARNING!** Do not operate engine without proper and operational spark arrester/muffler. Sparks emitted from the engine exhaust could ignite surrounding materials, causing serious injury or death.

3. See the engine manufacturer's manual for lubricating oil recommendations for specific temperature ranges.
4. Use #2 or better quality diesel fuel for above freezing starting. Use a #1 quality diesel fuel for below freezing starting.
5. Turn the key switch to the start (#2) position and release.
6. To turn off the engine, turn the key switch to the off (#0) position.

### **Electric Models (HR120)**

3. Turn the main disconnect switch to the ON position.
4. If necessary, release the emergency stop buttons (⊙) on the feed and electrical cabinet controls. Release the stop by turning it clockwise until it pops out.
5. To turn the resaw power on, push the green (⏻) button on the feed control box. The green power lights (⏻) on both the feed and electrical cabinet controls will illuminate when the power is on.
6. Press the green motor START button (⏻) located on the control cabinet to start the motor.
7. To turn off the motor, press the red motor STOP button on the control cabinet or either emergency stop button on the feed control or electrical cabinet. Turn the main disconnect switch to the OFF position.

***Electric Models (HR130)***

3. Turn the main disconnect switch to the ON position.
4. If necessary, release the emergency stop buttons (  ) on the operator and electrical cabinet controls. Release the stop by turning it clockwise until it pops out.
5. To turn the machine power on, push the green power button (  ) on the operator control box. The button power light will illuminate when the power is on.
6. Press the green blade motor START button (  ) located on the operator control to start the blade motor.
7. Press the green feed motor START button (  ) located on the operator control to start the blade motor.
8. To turn off a motor, press the red motor STOP button on the operator control. To stop all motors, push either emergency stop button on the operator control or electrical cabinet. Turn the main disconnect switch to the OFF position.

### 4.3 Clutch Operation

See **Figure 4-4**. The clutch/brake lever is located next to the engine/motor.

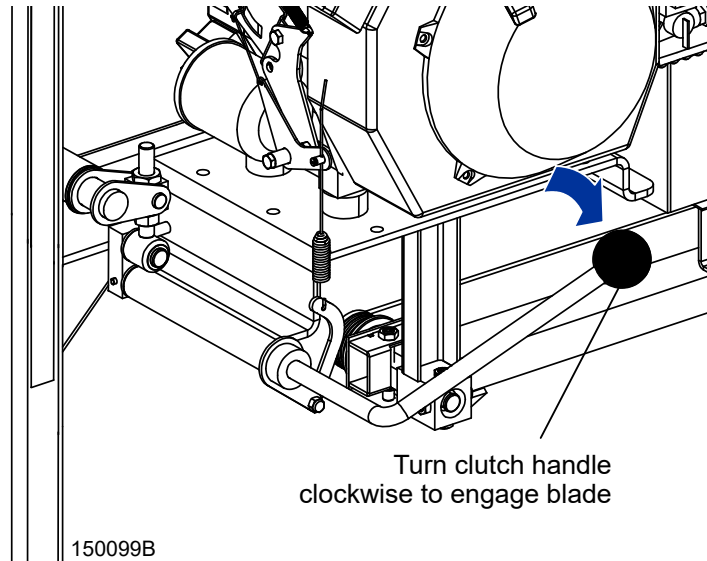

**FIG. 4-4**

1. To engage the blade, pull the clutch lever clockwise until it locks in the down position. This engages the drive mechanism and increases the engine speed to full throttle.
2. To disengage the blade, raise the clutch lever to the up position. This disengages the drive belt and returns the engine to idle (gas/diesel models only).

## 4.4 Feed Operation

1. Turn the feed rate switch ( ← ) clockwise to the desired feed rate.

See Figure 4-5.

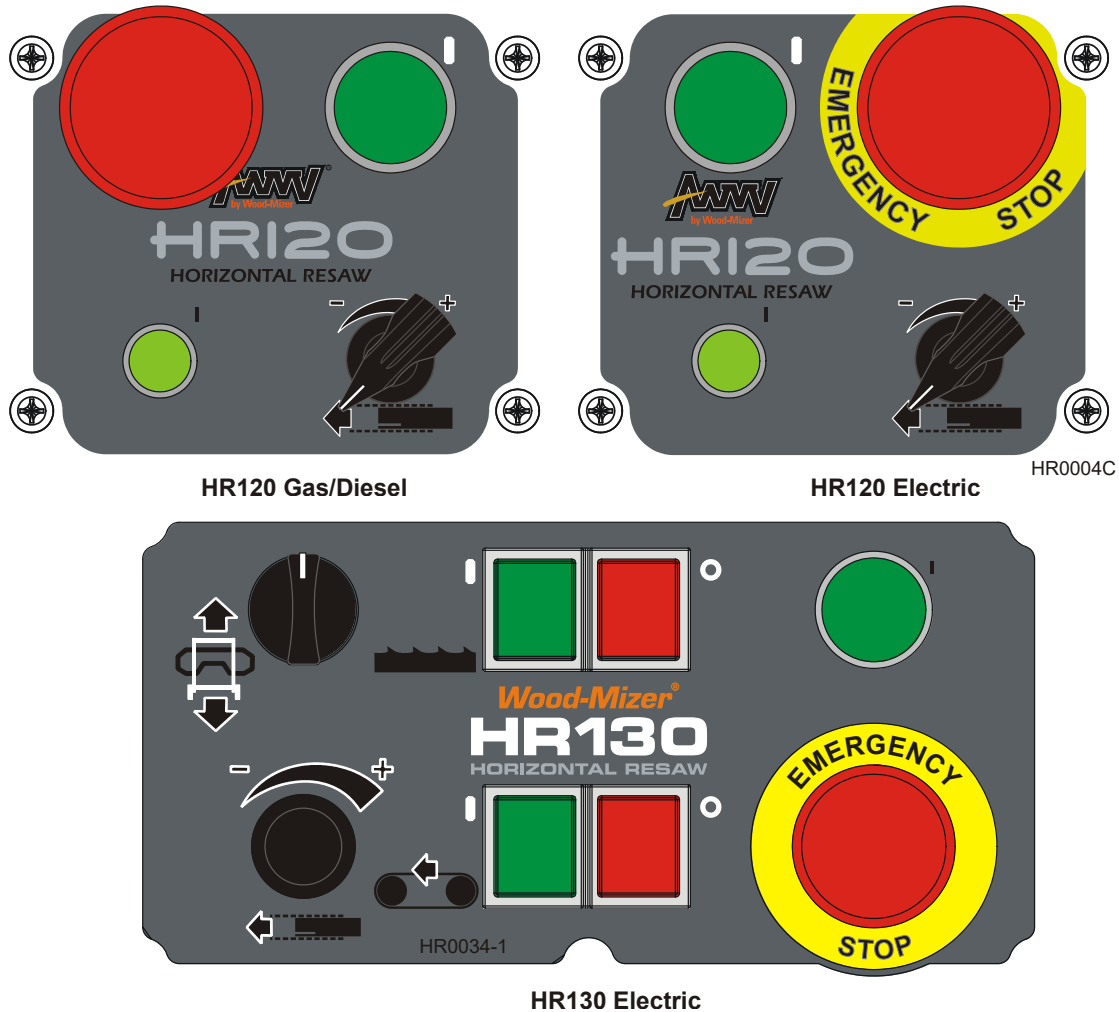

FIG. 4-5

2. Feed the first board into the resaw. Place the material on the feed belt, against the fence. When the blade starts to cut the board, turn the feed rate switch all the way down to stop the feed. Disengage the blade and pull the board out. Check the thickness of the cut and make any needed adjustments.

**NOTE:** Feed rate is affected by the species and the width of the board being cut. The sharpness, set of the blade, and the available horsepower of your engine also will affect the feed rate. If the engine continually "bogs" down, or if the quality of the cuts you are



making gets continually worse, adjust the feed rate or change the blade.

3. Turn the feed rate switch clockwise to the desired feed rate. Feed material continuously through the resaw. When material reaches the outfeed end of the belt, remove it and return it to the feed end if more cuts are desired.
4. When sawing is complete, turn the feed rate switch all the way counterclockwise, disengage the blade and stop the engine.

## 4.5 Water Lube Operation

The Water Lube System keeps the blade clean. Water flows from a 5-gallon (18.9 liter) bottle through a hose to the blade guide where the blade enters the log. A valve in the bottle cap controls the amount of water flow.

**See Figure 4-6.** Install the water bottle bracket at the top of the saw head mast. **NOTE:** The D17/G25 water tank tray also includes the fuel tank, but mounts to the mast in the same manner.

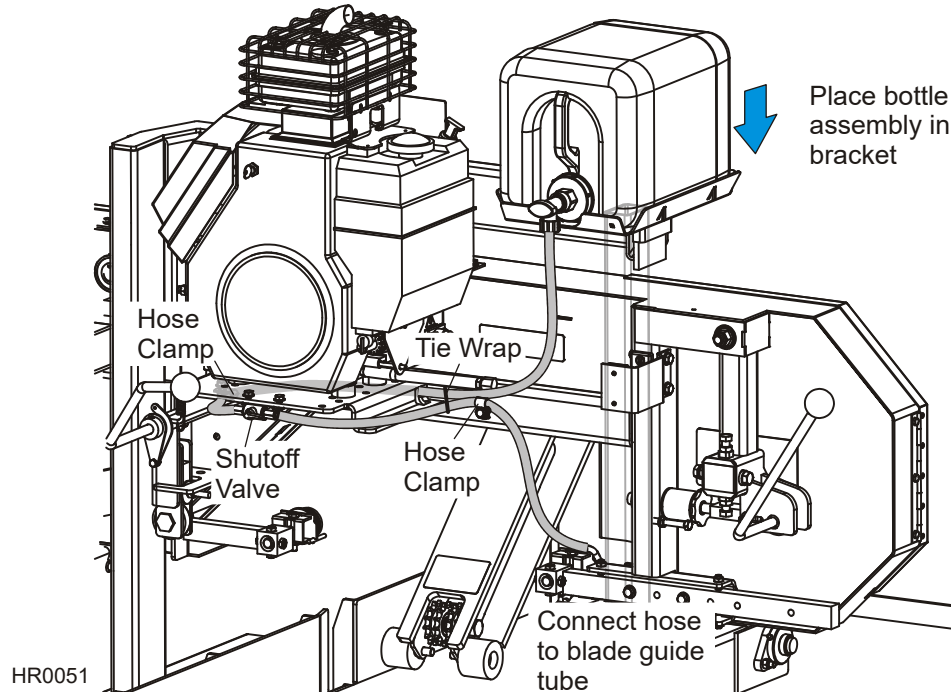

**FIG. 4-6**

See Figure 4-7.

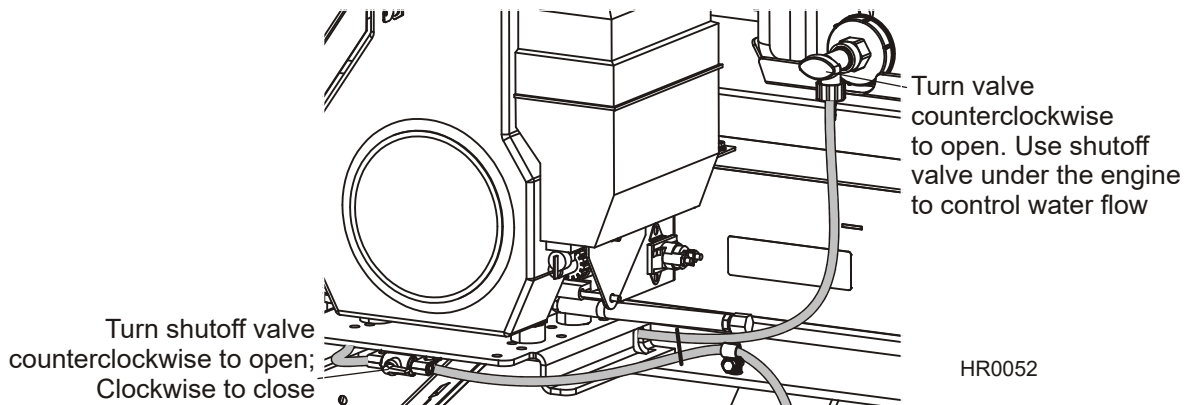

**FIG. 4-7**

Not all types of wood require the use of the Water Lube System. When it is needed, use just enough water to keep the blade clean. This saves water, and lowers the risk of staining the boards with water. Usual flow will be 1-2 gallons (3.8-7.6 liters) per hour.

Before removing the blade, engage the blade. Let the blade spin with water running on it for about 15 seconds. This will clean the blade of sap buildup. Wipe the blade dry with a rag before storing or sharpening.

For further lubrication benefits, add one 12oz. bottle of Wood-Mizer Lube Additive to 5 gallons of water. Wood-Mizer Lube Additive enables some previously impossible timbers to be cut by significantly reducing resin buildup on the blade. It helps to reduce heat buildup, wavy cuts, and blade noise. This biodegradable and environmentally friendly pre-mix includes a water softener additive, so it works with hard water.

 **WARNING!** Use **ONLY** water and Wood-Mizer Lube Additive with the water lube accessory. Never use flammable fuels or liquids such as diesel fuel. If these types of liquids are necessary to clean the blade, remove it and clean with a rag. Failure to do so can damage the equipment and may result in serious injury or death.

If you are sawing in freezing temperatures, remove the water lube bottle from the sawmill when done sawing and store it in a warm place. Blow any remaining water from the water lube hose.

## 4.6 Shingle Belt Operation (Optional)

1. Install the shingle belt and stop assembly as described in [Section 3.6](#).
2. Turn the resaw power on and use the feed rate switch to start the resaw shingle belt. Stop the belt to position a set of cleats in front of the shingle stop assembly. Push the emergency stop to turn resaw power off.
3. Place a stack of shingle blocks (two shingles thick, at least 18" and no more than 20" long) on the belt with the front of the blocks sitting on the tapered cleat. The rear end of the blocks should sit flat on the belt.
4. Loosen the stop assembly clamping bolts and adjust the assembly to approximately 1/4" above the bottom shingle block. Tighten the clamping bolts.

See Figure 4-8.

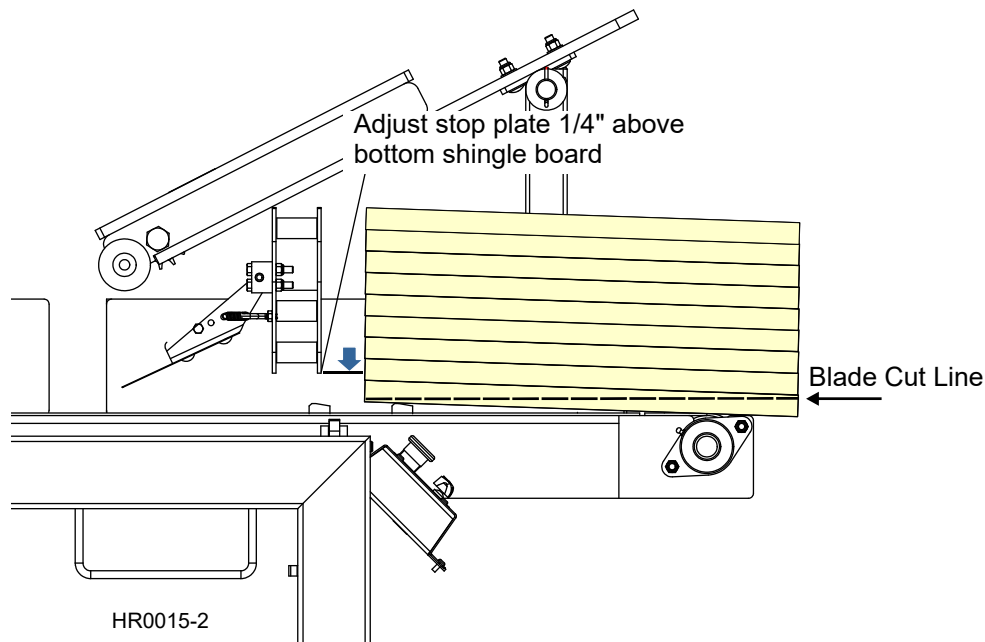



FIG. 4-8

5. Turn the resaw power on and use the up/down toggle switch (  ) to position the blade to cut the shingle blocks in half.



**DANGER!** Always be sure the blade is disengaged and all persons are out of the path of the blade before starting the motor. Failure to do so will result in serious injury.



**DANGER!** Always keep hands away from moving bandsaw blade. Failure to do so will result in serious injury.

**DANGER!** Always be aware of and take proper protective measures against rotating shafts, pulleys, fans, etc. Always stay a safe distance from rotating members and make sure that loose clothing or long hair does not engage rotating members resulting in possible injury.



**WARNING!** Secure all loose clothing and jewelry before operating this machine. Failure to do so may result in serious injury or death.

**WARNING!** Always wear eye, ear, respiration, and foot protection when operating or servicing this machine.

6. Turn the feed rate switch (  ) counterclockwise to its lowest setting.
7. Start the engine and engage the blade. Turn the feed rate switch (  ) clockwise to the desired feed rate.
8. Feed the first board into the Resaw. As the belt rotates, the bottom shingle block should pass under the stop plate and into the blade. When the blade starts to cut the board, turn the feed rate switch (  ) all the way down to stop the feed, turn the resaw power off, disengage the blade and pull the board out. Check the thickness of the cut and make any needed adjustments.
9. Place the block on top of the shingle board stack. Engage the blade and start the feed belt. The resaw will feed each shingle block through the blade. Add more shingle blocks to the stack as the stack gets shorter.

## SECTION 5 MAINTENANCE

### 5.1 Blade Guides



**WARNING!** Before performing service near moving parts such as blades, pulleys, motors, belts and chains, first turn the key switch to the OFF (#0) position and remove the key. If the key is turned on and moving parts activated, serious injury may result.

Check the rollers for performance and wear every blade change. Make sure the rollers are clean and spinning freely. If not, replace them. Replace any rollers which have worn smooth or have become cone shaped.

## 5.2 Sawdust Removal



**WARNING!** Before performing service near moving parts such as blades, pulleys, motors, belts and chains, first turn the key switch to the OFF (#0) position and remove the key. If the key is turned on and moving parts activated, serious injury may result.



Remove the excess sawdust from the blade wheel housings and sawdust chute every blade change.



**WARNING!** Always keep clear of exiting sawdust. Keep hands, feet and any other objects away from the sawdust chute when operating this machine. Failure to do so may result in serious injury.

**WARNING!** Always check to ensure the steel fingers inside the sawdust chute are in place before operating this machine. The steel fingers have been designed to help prevent a broken blade or some other object from becoming a projectile and exiting the sawdust chute. Failure to have these fingers in place may result in serious injury.

### 5.3 Vertical Mast Rails



**WARNING!** Before performing service near moving parts such as blades, pulleys, motors, belts and chains, first turn the key switch to the OFF (#0) position and remove the key. If the key is turned on and moving parts activated, serious injury may result.



Clean and lubricate the vertical mast rails every 50 hours of operation. Clean with solvent and remove any rust with a light-grade sand paper or emery cloth. Lubricate the mast with motor oil or automatic transmission fluid (ATF).



**CAUTION!** Never use grease on the mast rails as it will collect sawdust.



## 5.4 Blade Wheel Belts



**WARNING!** Before performing service near moving parts such as blades, pulleys, motors, belts and chains, first turn the key switch to the OFF (#0) position and remove the key. If the key is turned on and moving parts activated, serious injury may result.



Rotate the blade wheel belts and check them for wear. Rotating the belts every 50 hours will provide longer belt life. Replace belts as necessary. Use only B57 belts manufactured by Goodyear or Browning.

## 5.5 Drive Belt Adjustment



**WARNING!** Before performing service near moving parts such as blades, pulleys, motors, belts and chains, first turn the key switch to the OFF (#0) position and remove the key. If the key is turned on and moving parts activated, serious injury may result.

**WARNING!** Do not for any reason adjust the engine drive belt with the engine running. Doing so may result in serious injury.

 **See Table 5-1.** See the table below for drive belt tension specifications for your model sawmill.

Engine/Motor	After First	Then Every	Belt Tension
E10	20	50	1/2" (13mm) deflection with 7 lbs. of deflection force
D17/G18/G25	20	50	1/2" (13mm) deflection with 9 lbs. of deflection force <sup>1</sup>

**TABLE 5-1**

<sup>1</sup> If installing a new drive belt, initially tension the belt to 14 lbs. then 9 lbs. for subsequent adjustments.

To adjust the drive belt tension:

1. Loosen the drive belt jam and hex nuts. Turn the jam nut counterclockwise (as viewed from the top) to tighten the belt, clockwise to loosen the belt.

See Figure 5-1.

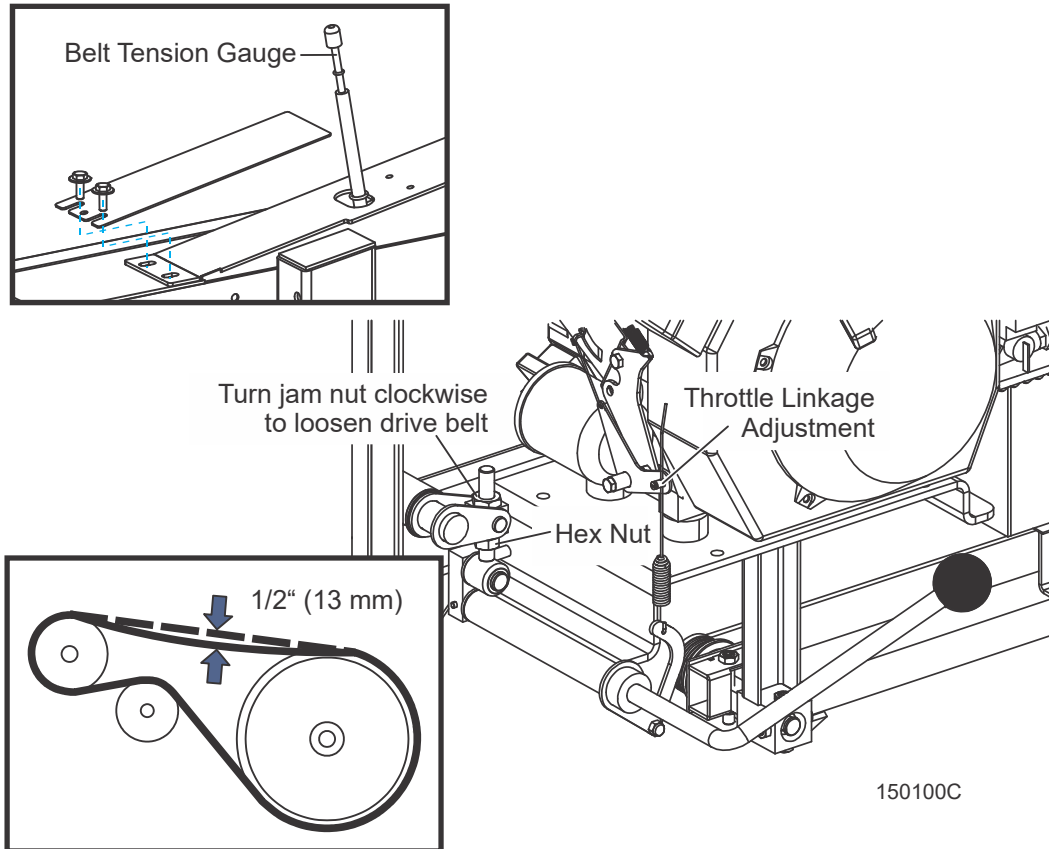

FIG. 5-1

2. After tensioning the drive belt, check the throttle linkage and adjust if necessary. With the clutch handle engaged, the throttle linkage should move the throttle lever to full speed. To adjust, loosen the throttle linkage adjustment screw and slide the throttle linkage down. Retighten the screw.



Periodically check the drive belt for wear. Replace any damaged or worn belts as needed.

## 5.6 Charging The Battery



**DANGER!** Batteries expel explosive gases. Keep sparks, flames, burning cigarettes, or other ignition sources away at all times. Always wear safety goggles and a face shield when working near batteries. Failure to do so will cause serious injury.<sup>1</sup>



**WARNING!** Battery posts, terminals and related accessories contain lead and lead compounds, chemicals known to the State of California to cause cancer and reproductive harm. Wash hands after handling.



**WARNING!** Charge the battery in a well ventilated area. Do not attempt to charge a frozen battery.

Use extreme care to avoid spilling or splashing electrolyte (which is dilute sulfuric acid) as it can destroy clothing and burn the skin. If electrolyte is spilled or splashed on clothing or the body, it should be neutralized immediately and then rinsed with clean water. A solution of baking soda, or household ammonia, and water may be used as a neutralizer.

Electrolyte splashed into the eyes is extremely dangerous. If this should happen, force the eye open and flood it with cool, clean water for approximately fifteen minutes. A doctor should be called immediately when the accident occurs and "on-the-spot" medical attention given if possible. If a doctor cannot come to the scene of the accident immediately, follow his instructions concerning actions to take. Do not add eye drops or other medication unless advised to do so by the doctor. Do not place a battery or acid within the reach of children. If acid (electrolyte) is taken internally drink large quantities of water or milk. Follow with milk of magnesia, beaten egg or vegetable oil. Call a physician immediately.

If electrolyte is spilled or splashed on any surface of the machine, it should be neutralized and rinsed with clean water.



**CAUTION!** Do not overcharge the battery. Overcharging may reduce the overall service life of the battery.

---

<sup>1</sup>Battery Council International, copyright 1987

**CAUTION!** Be sure the battery is fully charged before transporting the sawmill. If the battery is not fully charged, excessive vibration could reduce the overall service life of the battery.

1. Turn the key to the OFF (#0) position and remove the key.
2. Remove the battery box lid.
3. Clean the battery terminals if necessary.
4. Connect the positive charger/jumper cable directly to the positive battery terminal.
5. Connect the negative charger/jumper cable to a grounded metal surface.
6. Follow the instructions supplied with your specific battery charger.





**IMPORTANT:** Be careful not to overcharge the battery, especially when using a high-rate or “boost” charger (40 amps or higher). These are intended to quickly charge a good battery that is discharged. They are not intended for unattended or long-term charging.

7. After the battery is completely recharged, remove the negative charger/jumper cable from ground.
8. Remove the positive charger/jumper cable from the battery.
9. Replace the battery box lid.

## 5.7 Feed System



**WARNING!** Before performing service near moving parts such as blades, pulleys, motors, belts and chains, first turn the key switch to the OFF (#0) position and remove the key. If the key is turned on and moving parts activated, serious injury may result.

-  1. Grease the conveyor belt roller bearings and the hold-down pivot with a NLGI No. 2 grade lithium grease every 1000 hours of operation.
-  2. Periodically check the conveyor belt for wear. Replace a damaged or worn belt as needed. Always check the conveyor belt alignment after installing a new belt. Align the conveyor belt after replacing as necessary ([See Conveyor Belt Alignment](#) in [Section 6.1](#)).

## SECTION 6 ALIGNMENT

### 6.1 Complete Alignment Procedure



**WARNING!** Before performing service near moving parts such as blades, pulleys, motors, belts and chains, first turn the key switch to the OFF (#0) position and remove the key. If the key is turned on and moving parts activated, serious injury may result.

1. Install a blade ([See Section 3.8](#) through [3.9](#)).
2. Measure the distance from the conveyor belt to the bottom of the blade near the inside blade guide.
3. Measure the distance from the conveyor belt to the bottom of the blade near the outside blade guide.

When the blade is parallel to the belt, it will measure the same distance from the belt at the inside and outside of the saw head.

# 6

## Alignment

### Complete Alignment Procedure

See **Figure 6-1**. Turn the saw head tilt adjustment nut clockwise to raise the outside of the saw head. Turn the nut counterclockwise to lower the outside of the saw head. After the saw head is adjusted parallel to the conveyor belt, check the space between the uppermost mast bearing and mast rail. Adjust as necessary so the space is 1/32" - 1/16".

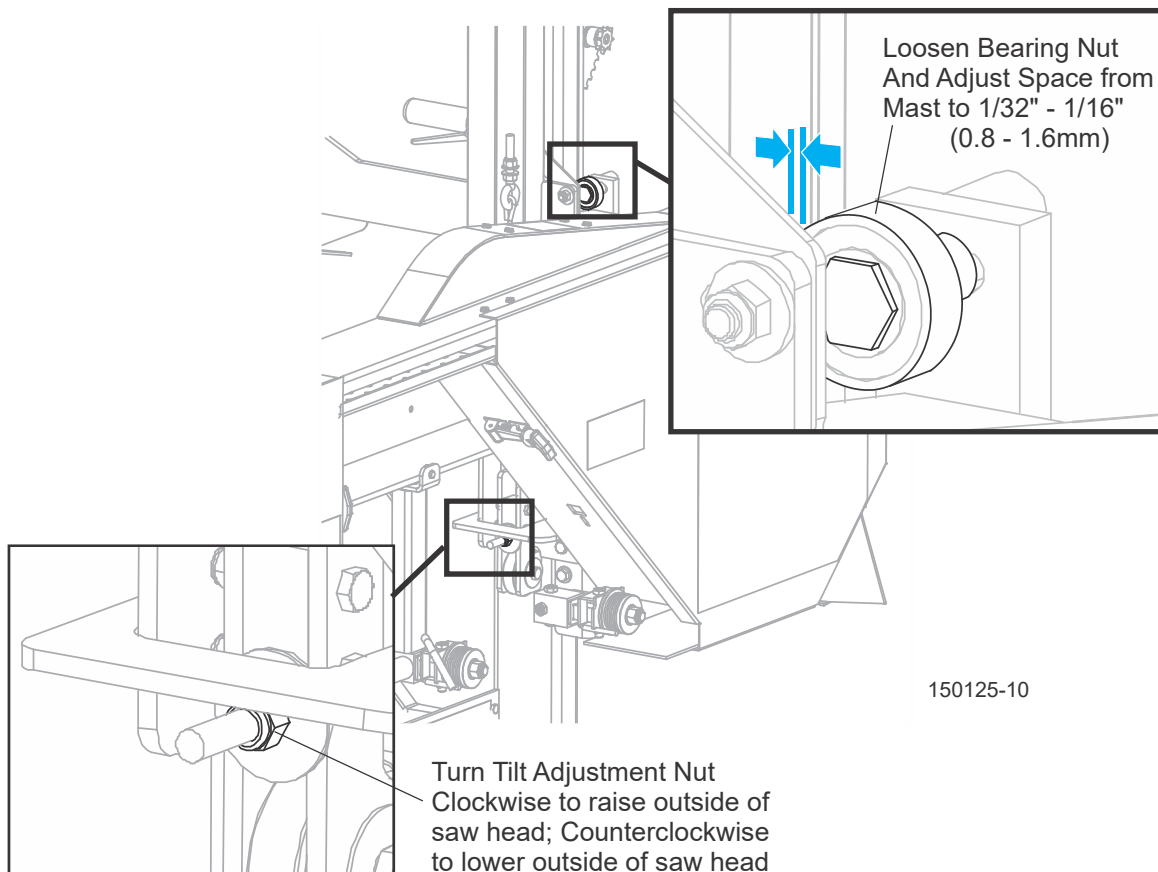

**FIG. 6-1**



### **Blade Installation**

1. Remove the blade and replace the blade wheel belts. New blade wheel belts are required to perform the complete alignment procedure.
2. Blow sawdust off of the blade guide assemblies. Remove sawdust from the blade housings.
3. Remove the blade guide assemblies.

**NOTE:** To remove the blade guide assemblies and maintain the tilt adjustments, only loosen one side screw and the top screw. Leaving the other side screw and bottom screw in position will insure you will return the rollers to their original tilt adjustment.

4. Relocate the outer blade guide arm to position the outer blade guide furthest from the inner blade guide ([See Section 3.4](#)).
5. Install a new blade and apply the appropriate tension ([See Section 3.7](#)).
6. Close the blade housing covers and make sure all persons are clear of the saw head.
7. Start the engine.
8. Engage the blade, rotating the blade until the blade positions itself on the wheels.



**WARNING!** Do not spin the blade wheels by hand. Spinning the blade wheels by hand may result in serious injury.

9. Disengage the blade. Turn the engine off.

**Blade Wheel Alignment**

The blade wheels should be adjusted so they are level in the vertical and horizontal planes. If the blade wheels are tilted up or down, the blade will want to travel in the tilted direction. If the blade wheels are tilted horizontally, the blade will not track properly on the wheels.

1. Use the blade guide alignment tool to check the vertical alignment of each blade wheel. Attach the tool to the blade near the inner blade guide mount. Be sure the tool does not rest on a tooth or burr, and is lying flat against the bottom of the blade.

**See Figure 6-2.**

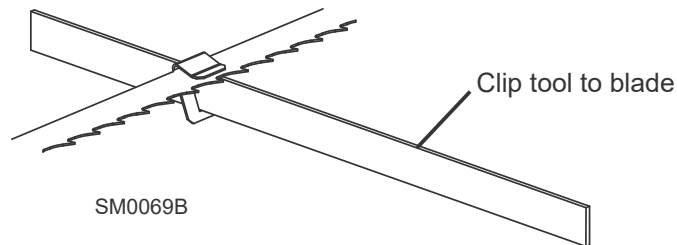
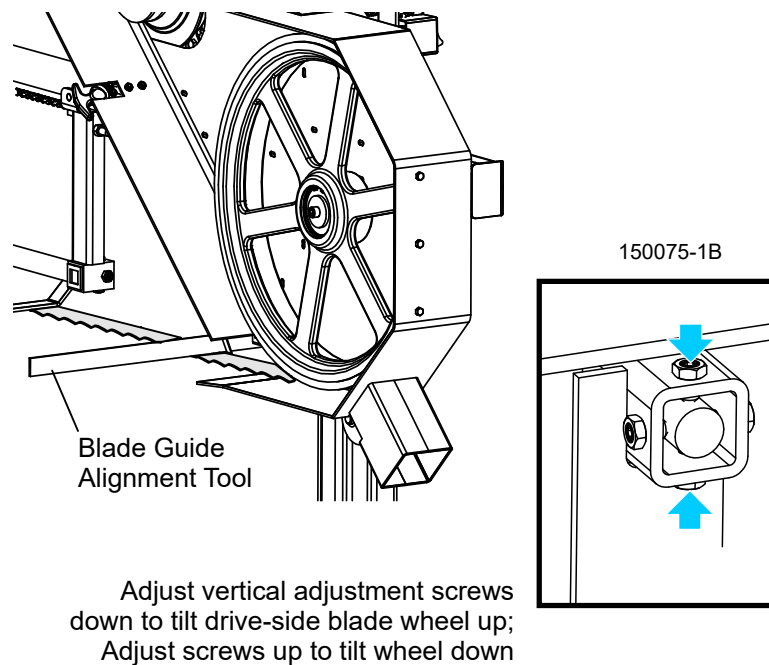

**FIG. 6-2**

2. Measure from the bottom of the tool to the top surface of the conveyor belt at the front and rear ends of the tool.
3. If the two measurements differ by more than 1/16" (1.5 mm), adjust the vertical tilt of the drive-side blade wheel.

**See Figure 6-3.** Use the vertical adjustment screws to adjust the drive-side blade wheel. To tilt the wheel down, loosen the top adjustment screw one quarter turn. Loosen the jam nut on the bottom adjustment screw and tighten the screw. Tighten the top and bottom jam nuts.

To tilt the wheel up, loosen the bottom adjustment screw one quarter turn. Loosen the jam nut on the top adjustment screw and tighten the screw. Tighten the top and bottom jam nuts.



**FIG. 6-3**

4. Recheck the vertical tilt of the drive-side blade wheel with the blade guide alignment tool. Readjust the blade wheel as necessary until the front and rear of the tool are the same distance from the conveyor belt (within 1/16" [1.5 mm]).
5. Remove the tool from the blade and reattach it near the outer blade guide assembly.
6. Measure from the tool to the conveyor belt at both ends of the tool. If the measurements at the front and rear ends of the tool differ by more than 1/16" (1.5 mm), adjust the vertical tilt of the idle-side blade wheel.

# 6

## Alignment

### Blade Wheel Alignment

**See Figure 6-4.** Use the vertical adjustment screws to adjust the idle-side blade wheel. To tilt the wheel up, loosen the bottom adjustment screw one quarter turn. Loosen the jam nut on the top adjustment screw and tighten the screw. Tighten the top and bottom jam nuts.

To tilt the wheel down, loosen the top adjustment screw one quarter turn. Loosen the jam nut on the bottom adjustment screw and tighten the screw. Tighten the top and bottom jam nuts.

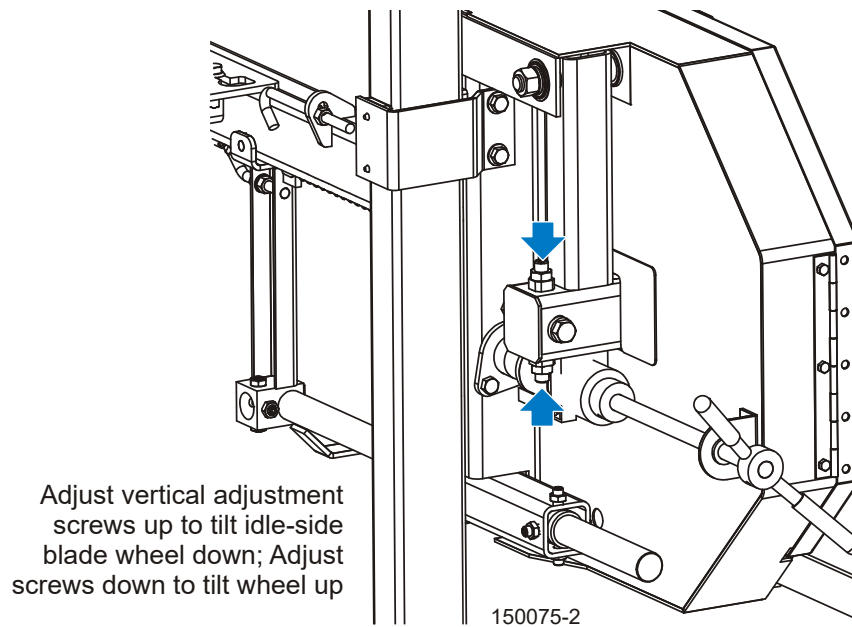
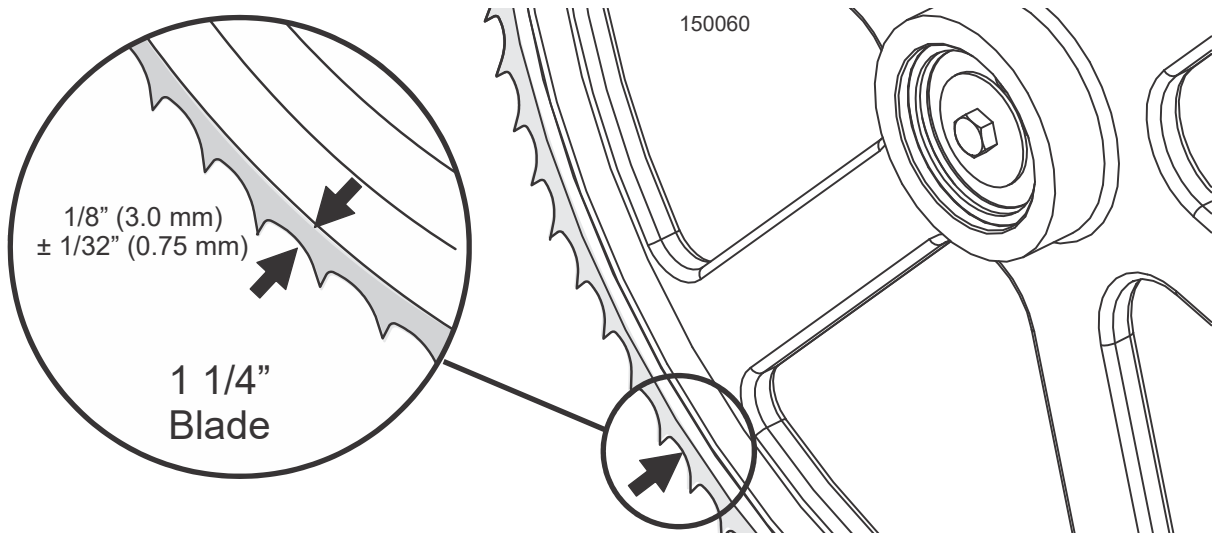

**FIG. 6-4**

7. Recheck the vertical tilt of the idle-side blade wheel with the blade guide alignment tool. Readjust the blade wheel as necessary until the front and rear of the tool are the same distance from the conveyor belt (within 1/16" [1.5 mm]).

8. Check the position of the blade on the idle-side blade wheel.

**See Figure 6-5.** The horizontal tilt of the blade wheel should be adjusted so that the gullet of an 1-1/4" blade is 1/8" (3 mm) out from the front edge of the wheel ( $\pm 1/32$  [0.75 mm]).



**FIG. 6-5**

**See Figure 6-6.** Use the cant control adjustment to adjust the idle-side blade wheel. If the blade is too far forward on the wheel, turn the cant control counterclockwise. If it is too far back on the wheel, turn the cant control clockwise.

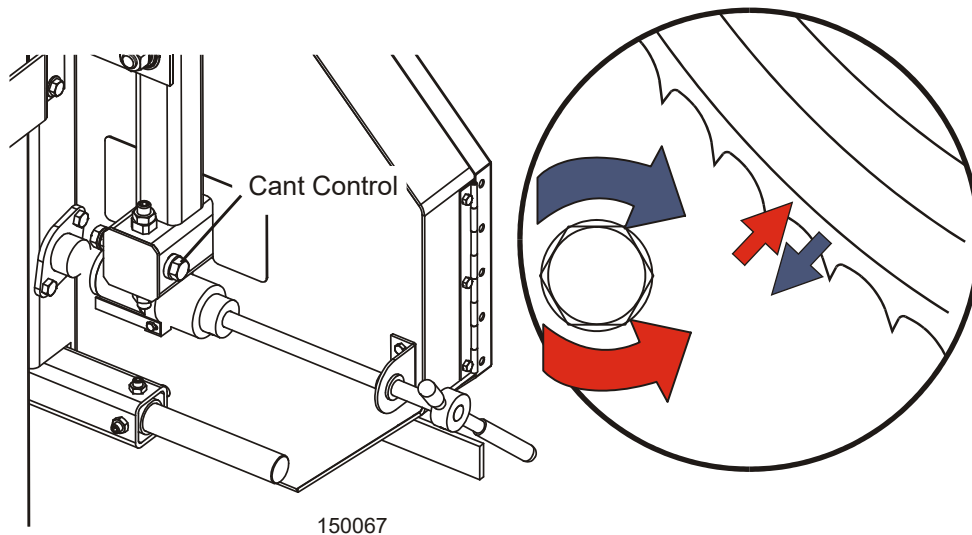

**FIG. 6-6**

9. Check the position of the blade on the drive-side blade wheel. The blade should be positioned on the wheel as described for the idle-side blade wheel. Adjust the drive-side blade wheel if necessary.

# 6

## Alignment

### Blade Wheel Alignment

**See Figure 6-7.** Use the horizontal adjustment screws to adjust the drive-side blade wheel. To move the blade back on the wheel, loosen the right adjustment screw one quarter turn. Loosen the jam nut on the left adjustment screw and tighten the screw. Tighten the left and right jam nuts.

To move the blade out on the wheel, loosen the left adjustment screw one quarter turn. Loosen the jam nut on the right adjustment screw and tighten the screw. Tighten the left and right jam nuts.

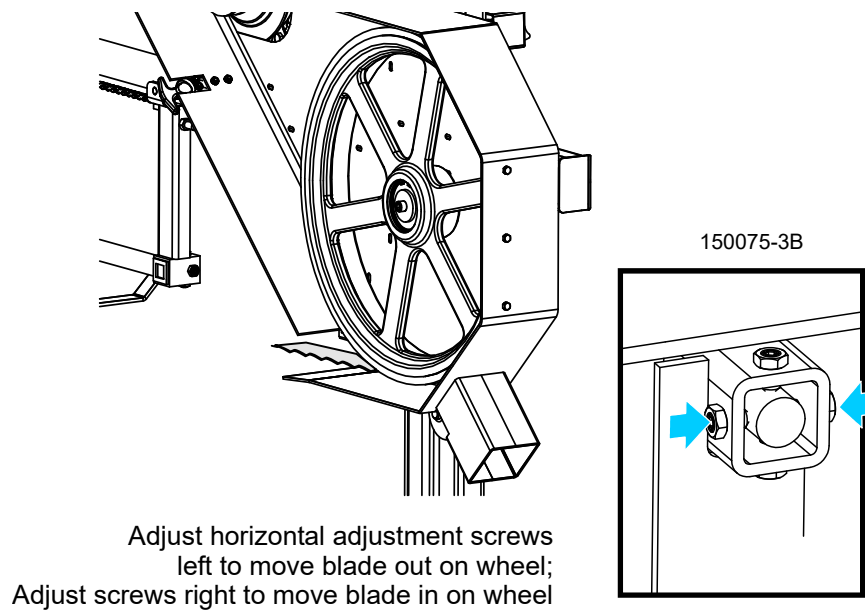

**FIG. 6-7**

### Blade Guide Installation

Each resaw has two blade guide assemblies that help the blade maintain a straight cut. The two blade guide assemblies are positioned on the saw head to guide the blade on each side of the material being cut.

One blade guide assembly is mounted in a stationary position on the drive side of the saw head. This assembly is referred to as the "inner" blade guide assembly.

The other blade guide assembly is mounted on the idle side of the saw head. It is referred to as the "outer" assembly and is adjustable for various widths of materials to be processed.

**NOTE:** Before installing the blade guide assemblies, remove the blade guide adjusting screws and apply a lubricating oil such as 10W30 or Dexron III to each screw. This will prevent the screws and threaded holes from corroding and make screw adjustments easier.

1. Install the outer blade guide assembly (with waterlube tube) to the mounting block on the blade guide arm. Position the assembly so the roller flange is 1/8" (3.0 mm) from the blade.
2. Install the inner blade guide assembly to the mounting block on the saw head. Position the assembly so the roller flange is 1/16" (1.5 mm) from the blade.

**See Figure 6-8.** Tighten the two previously-loosened tilt adjustment screws to secure the blade guide assembly.

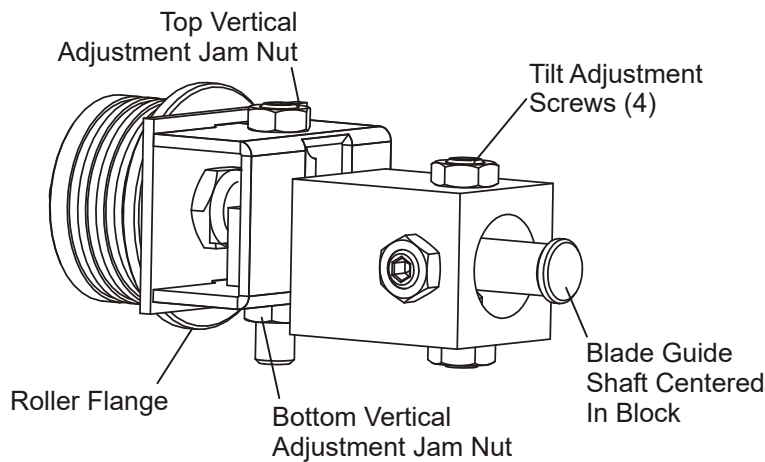

FIG. 6-8

# 6

## Alignment

### Blade Guide Arm Alignment

#### Blade Guide Arm Alignment

The blade guide arm should be parallel to the blade in the vertical and horizontal directions.

1. Relocate the outer blade guide arm to position the outer blade guide closest to the inner blade guide ([See Section 3.4](#)).
2. Place a straight edge on the conveyor belt that will extend the length of the blade guide arm.
3. Measure from the bottom of the blade guide arm to the straight edge at both ends of the arm. The distance to the straight edge should be the same (within 1/32") at each end.

**See Figure 6-9.** Loosen the mounting bolts and use the vertical adjustment screws to tilt the arm. Loosen the jam nuts and turn the screws as necessary until the arm is parallel to the straight edge. Retighten the jam nuts.

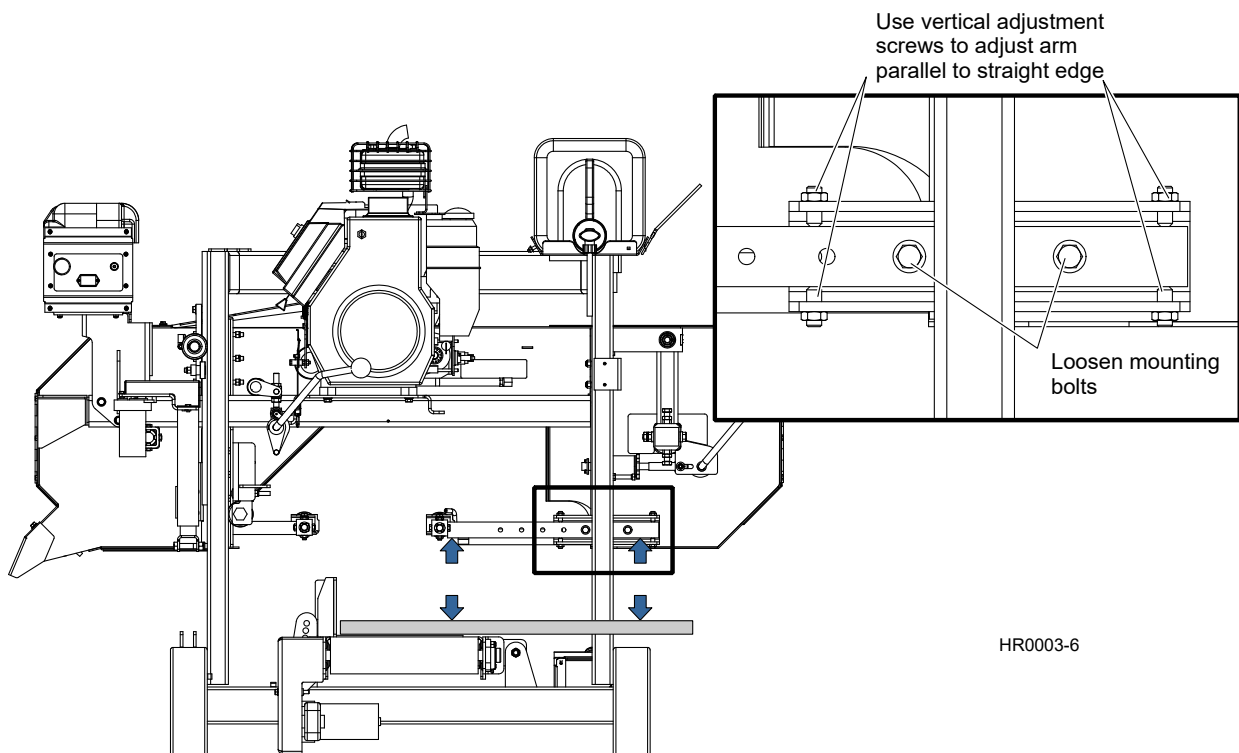
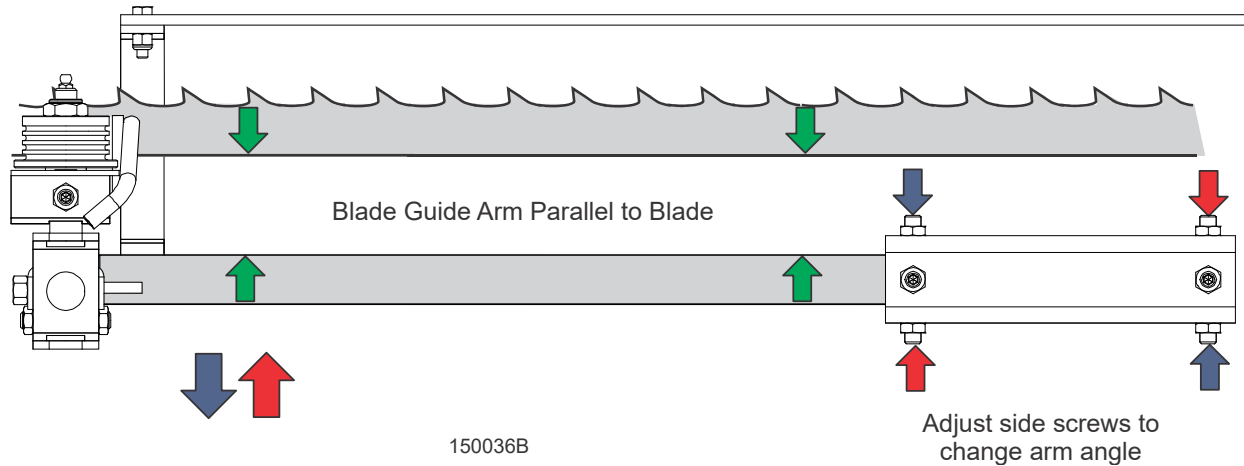

FIG. 6-9



See **Figure 6-10**. With the blade guide arm still all the way in toward the other blade guide, tighten all the side screws until they touch the arm. Back the screws off 1/4 turn and tighten the jam nuts.



**FIG. 6-10**

4. Measure the distance between the blade guide arm and back edge of the blade. Adjust the appropriate side screws on the blade guide arm housing so the arm is measures the same distance from the blade at both ends of the arm.
5. To move the blade guide end of the arm toward the front of the resaw, loosen jam nuts on the front inside screw and the rear outside screw. Turn the screws counterclockwise one full turn and tighten the jam nuts. Loosen the jam nuts on the front outside screw and the rear inside screw. Turn the screws clockwise until they touch the arm, back off 1/4" turn, and tighten the jam nuts.
6. To move the blade guide end of the arm toward the rear of the resaw, loosen jam nuts on the front outside screw and the rear inside screw. Turn the screws counterclockwise one full turn and tighten the jam nuts. Loosen the jam nuts on the front inside screw and the rear outside screw. Turn the screws clockwise until they touch the arm, back off 1/4" turn, and tighten the jam nuts.

### Blade Guide Deflection

Perform the following steps to achieve proper blade deflection with the blade guides.

1. Raise the saw head until the blade is 6" (150 mm) above the conveyor belt. Measure the actual distance with a tape from the top of the belt to the bottom of the blade.
2. Make sure the two vertical adjustment set screws are threaded into the blade guide shaft until they touch each other.

See Figure 6-11.

Loosen the bottom jam nut and tighten the top jam nut until the blade guide deflects the blade down until the bottom of the blade measures 5 3/4" (144 mm) from the conveyor belt.

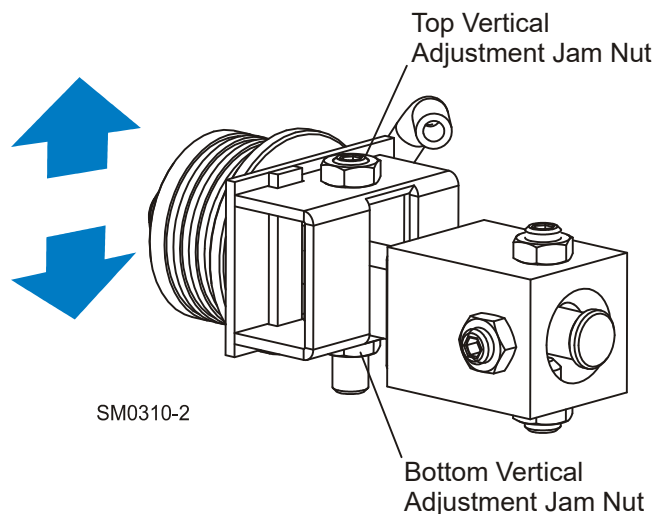

FIG. 6-11

3. Repeat for the other blade guide.

**NOTE:** Be sure that the blade guide deflector rod clears the blade on both guide assemblies. The rod on the outer guide assembly should be checked with the arm all the way in and all the way out.

### Blade Guide Vertical Tilt Alignment

The blade guides should be adjusted properly in the vertical plane. If the blade guides are tilted vertically, the blade will try to travel in the tilted direction.

A Blade Guide Alignment Tool (BGAT) is provided to help you measure the vertical tilt of the blade.

1. Open the adjustable blade guide arm 1/2" (15 mm) from full open.
2. Clamp the alignment tool on the blade. Position the tool close to the outer blade guide roller. Be sure the tool does not rest on a tooth or burr, and is lying flat on the blade.

See Figure 6-12.

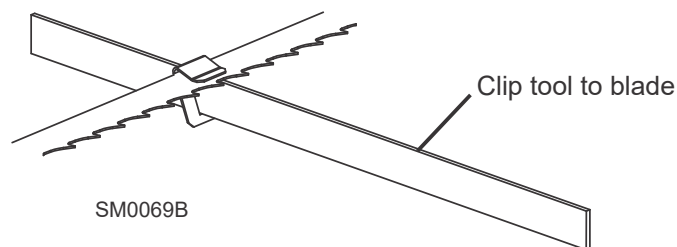

**FIG. 6-12**

3. Measure from the bottom of the tool to the top surface of the conveyor belt at the front and rear ends of the tool.
4. If the measurement from the tool to the belt is not equal within 1/32" (.75 mm), adjust the vertical tilt of the outer blade guide roller.
5. Loosen one set screw at the side of the blade guide assembly.

# 6

## Alignment

### Blade Guide Vertical Tilt Alignment

See **Figure 6-13**. Loosen the jam nuts on the top and bottom vertical tilt adjustment screws. To tilt the roller up, loosen the bottom screw and tighten top screw. To tilt the roller down, loosen the top screw and tighten the bottom screw. Tighten the jam nuts and recheck the tilt of the blade.

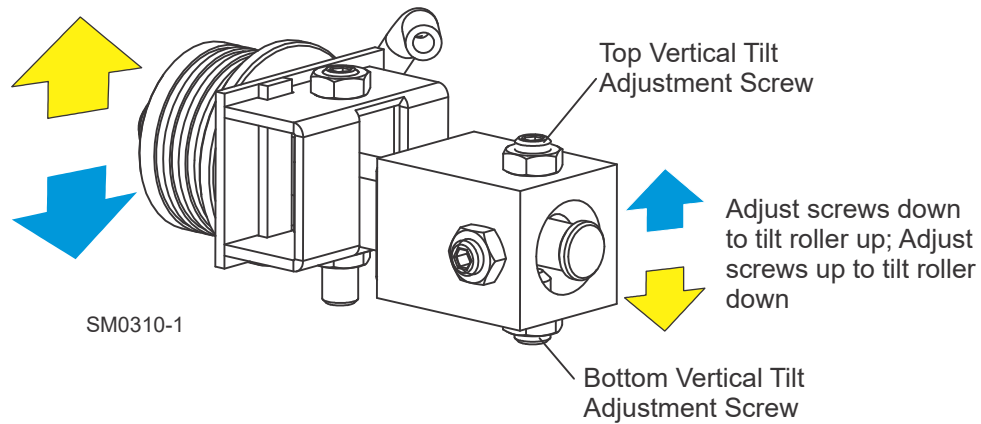

**FIG. 6-13**

6. Move the blade guide alignment tool close to the inner blade guide roller assembly and repeat the above steps. Adjust the vertical tilt of the inner blade guide if necessary.
7. After adjusting the vertical tilt of the blade guides, recheck the blade deflection and adjust if necessary.

### Blade Guide Horizontal Tilt Adjustment

If the blade guides are tilted in the wrong direction horizontally, the back of the blade may contact the flange as the roller is spinning down, causing it to push the blade away from the guide roller.

1. Remove the blade guide alignment tool from the blade and adjust the blade guide arm halfway in.
2. Remove the clip from the blade guide alignment tool. Place the tool against the face of the outer blade guide roller.

See Figure 6-14.

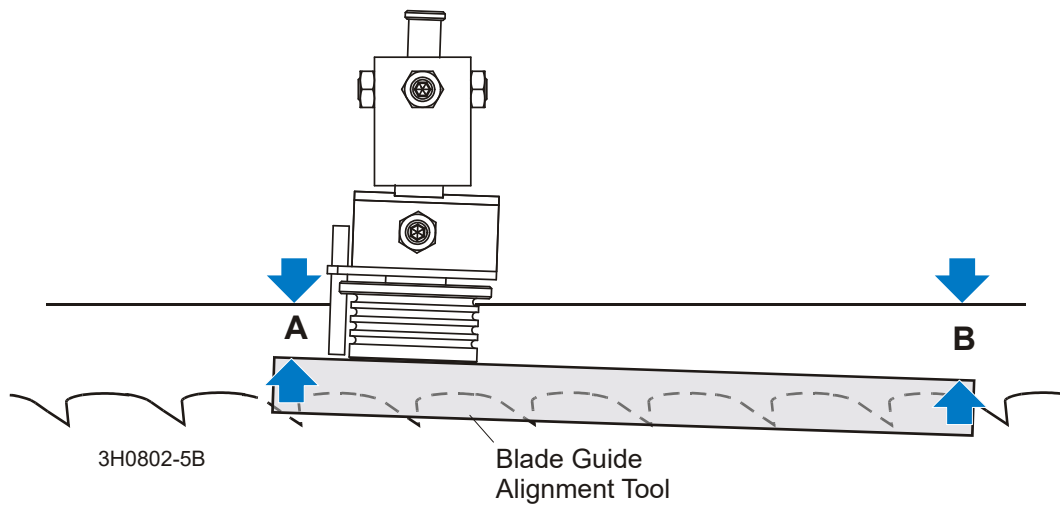

**FIG. 6-14**

3. Measure between the back edge of the blade and the tool at the end closest to the inner blade guide ("B").
4. Measure between the back edge of the blade and the other end of the tool ("A").

The roller should be tilted slightly to the left ('A' 1/8" [3 mm] less than 'B' ±1/8" [3 mm]).

# 6

## Alignment

### Blade Guide Horizontal Tilt Adjustment

**See Figure 6-15.** Loosen the jam nuts on the horizontal tilt adjustment screws. To tilt the roller left, loosen the right screw and tighten left screw. To tilt the roller right, loosen the left screw and tighten the right screw. Tighten the jam nuts and recheck the tilt of the blade.

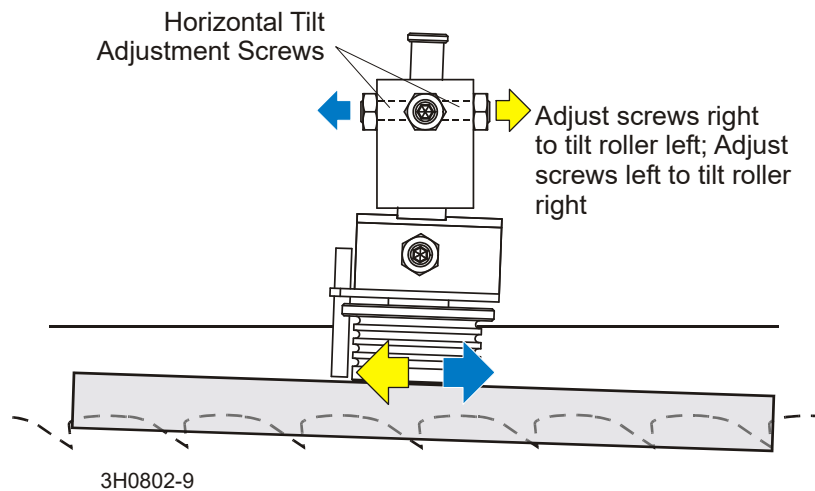

**FIG. 6-15**

5. Repeat the above steps for the inner blade guide roller assembly.

**NOTE:** Once the blade guides have been adjusted, any cutting variances are most likely caused by the blade. [See \*Blade Handbook, Form #600.\*](#)

### Blade Guide Flange Spacing

Each blade guide must be adjusted so the roller flange is the correct distance from the back edge of the blade. If the flange is too close to or too far from the blade, the resaw will not cut accurately.

**HINT:** When adjusting blade guide spacing, loosen the top set screw and one side set screw only. This will ensure horizontal and vertical tilt adjustments are maintained when the adjustment screws are retightened.

1. Measure the distance between the flange on the outer blade guide roller to the back edge of the blade. This distance should measure 1/8" (3.0 mm). Adjust the roller back or forward if necessary.

**See Figure 6-16.** Loosen the top and one side screw shown. Tap the blade guide forward or backward until properly positioned. Retighten the screws and jam nuts.

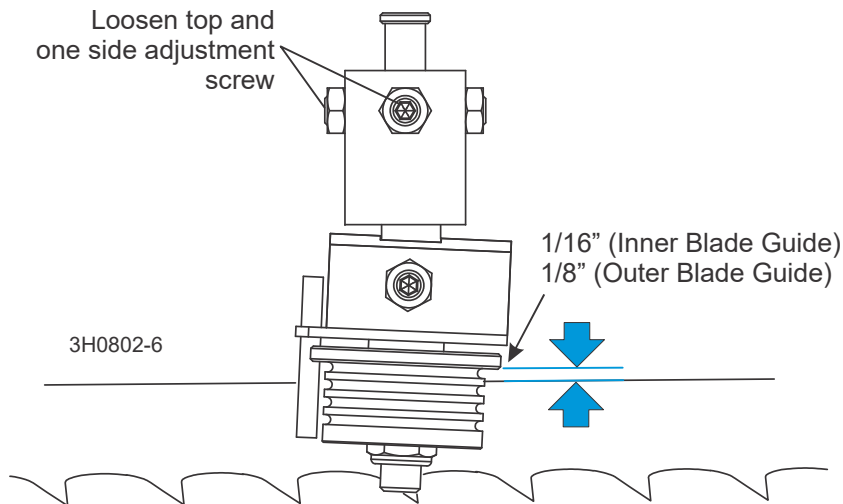

**FIG. 6-16**

2. Measure the distance between the flange on the inner blade guide roller to the back edge of the blade. This distance should measure 1/16" (1.5 mm). Adjust the roller back or forward if necessary.

# 6

## Alignment

### Blade Height Scale Adjustment

#### Blade Height Scale Adjustment

After the entire resaw has been aligned and all adjustments made, check that the blade height scale indicates the true distance from the blade to the bed rails.

1. Measure from the bottom edge on a down-set tooth of the blade to the top of the feed conveyor belt, near the inner blade guide assembly.
2. View the blade height scale with eyes level with the indicator. The scale should indicate the actual distance from the blade to the belt. Adjust the indicator if necessary.

**See Figure 6-17.** Loosen the indicator bracket mounting nut. Adjust the bracket up or down until the indicator is aligned with the correct mark on the scale (+0 -1/32 [0.8 mm]). Retighten the indicator mounting nut.

For example, if the measurement from the down-set tooth of the blade to the belt was 4 3/4", make sure the indicator reads 4 3/4" on the scale.

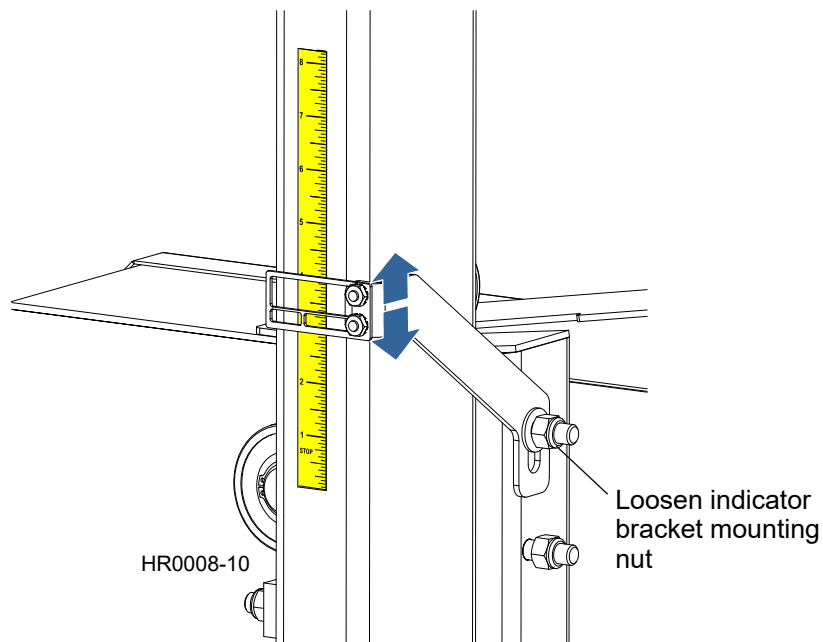

FIG. 6-17



### Conveyor Belt Alignment

If the conveyor belt begins to slip, perform the following steps to tighten the belt:

1. Loosen the tensioner locking bolts on both sides of the frame. Loosen the outer jam nut on each adjustment bolt. Use a wrench to hold the adjustment bolt and turn the inner jam nut clockwise to push the conveyor belt roller out. Turn the adjustment bolts on each side of the frame equally. Only tighten the belt until it no longer slips. Retighten outer jam nuts and the locking bolts.

See Figure 6-18.

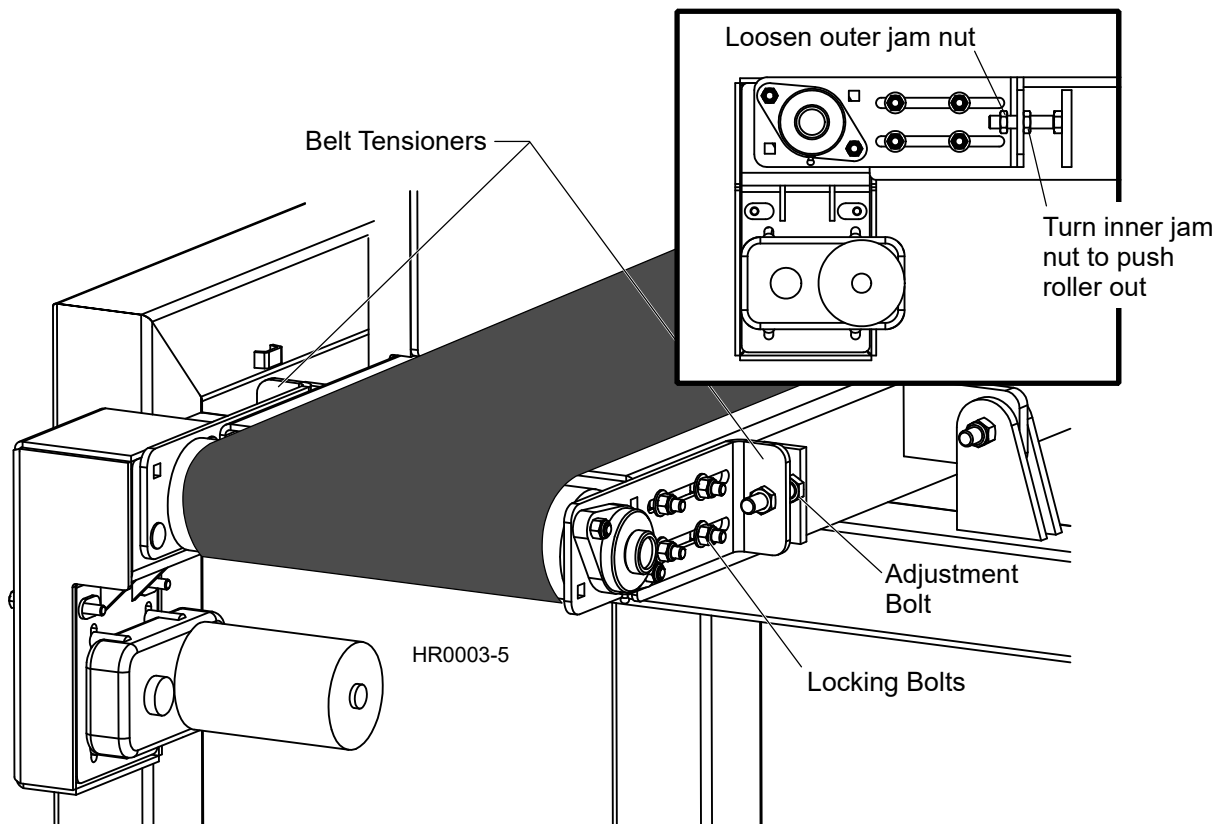

FIG. 6-18

2. After tightening the belt, run the belt for a few minutes and make sure the belt remains centered on the drive rollers while running. If the conveyor belt keeps traveling to one side or the other, loosen the belt tensioner locking bolts on one side of the belt. Use a wrench to hold the alignment bolt and adjust the jam nuts to move the end of the roller in or out.

# 6

## Alignment

### Conveyor Belt Alignment

**See Figure 6-19. Example:** If the belt is tracking to the left, extend the left tensioner bracket out to move the belt to the right. Adjust in small increments until the belt travels straight. Retighten the locking nuts.

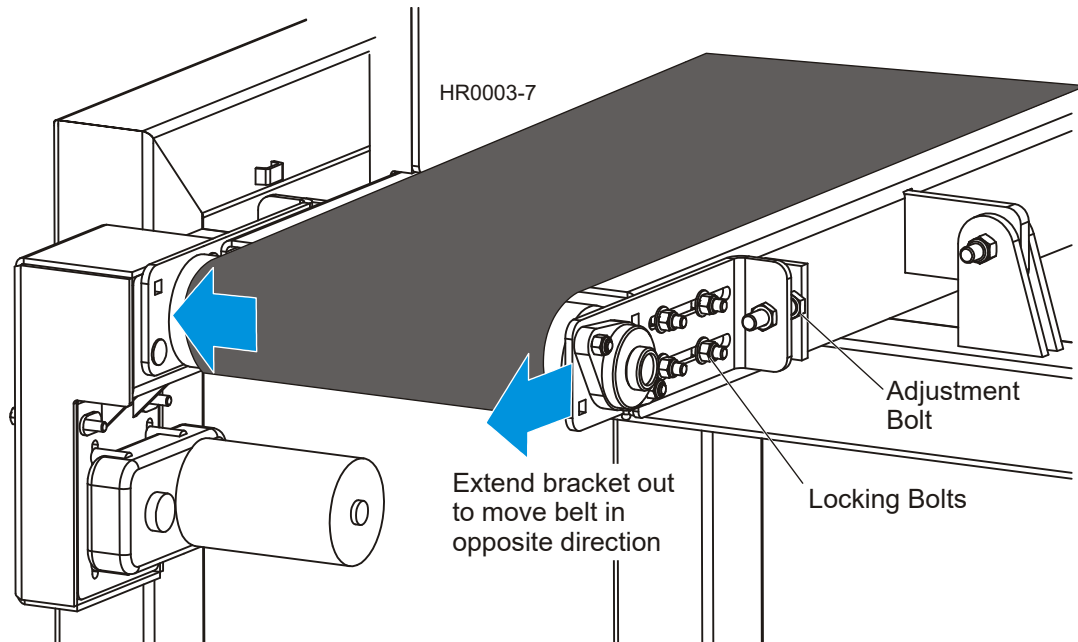

**FIG. 6-19**



Periodically check the conveyor belt for wear. Replace a damaged or worn belt as needed. Always check the conveyor belt alignment after installing a new belt. Align the conveyor belt after replacing as necessary.

---

## SECTION 7 ELECTRICAL INFORMATION

See [Appendix HR120/HR130 Electrical Information \(Form #2224\)](#) for complete electrical information including electrical component lists, electrical component layouts and wiring diagrams.

# INDEX

---

## A

alignment 6-1

---

## M

maintenance

- battery charging 5-7
  - blade guides 5-1
  - blade wheel belts 5-4
  - drive belt 5-5, 5-9
  - mast rails 5-3
  - sawdust removal 5-2
- 

## O

operation

- blade clutch 4-7
  - feed 4-8
  - machine start 4-4
  - shingle belt (optional) 4-12
  - up/down 4-1
  - water lube 4-10
- 

## S

safety

- instructions 1-2
- lockout procedure 1-9
- symbols 1-1

service information

- branch locations 2-2
- customer & machine ID 2-6
- general contact info 2-1

setup

- blade installation 3-9
- blade tensioning 3-8
- blade tracking 3-10
- electrical installation 3-2
- guide arm adjustment 3-5
- hold-down adjustment 3-4
- resaw 3-1
- shingle belt installation (optional) 3-7
- table option 3-12
- tilt conveyor 3-6

specifications 2-3