

# Horizontal Cross Transfer Deck

## Safety, Operation and Maintenance Manual

---

SLPHCTD

rev.A6.00

---



**Safety is our #1 concern!** Read and understand all safety information and instructions before operating, setting up and/or maintaining this equipment.

*June 2008*

*Form #1015*

# Table of Contents

# Section-Page

<b>SECTION 1</b>	<b>SAFETY INSTRUCTIONS</b>	<b>1-1</b>
1.1	Safety Symbols.....	1-1
1.2	Safety Instructions.....	1-2
<b>SECTION 2</b>	<b>OPERATION</b>	<b>2-1</b>
2.1	Transfer Deck Components.....	2-1
2.2	Transfer Deck Setup.....	2-1
2.3	Transfer Deck Operation.....	2-4
<b>SECTION 3</b>	<b>MAINTENANCE</b>	<b>3-1</b>
3.1	Lubrication.....	3-1
3.2	Transfer Chain Tension.....	3-2
3.3	Drive Chain Tension.....	3-3
<b>SECTION 4</b>	<b>SPECIFICATIONS</b>	<b>4-1</b>
4.1	Transfer Deck Dimensions.....	4-1
4.2	Motor Specifications.....	4-3
4.3	Electrical Diagram.....	4-3
4.4	Electrical Components List.....	4-4
<b>SECTION 5</b>	<b>REPLACEMENT PARTS</b>	<b>5-1</b>
5.1	Front Module & Chains.....	5-1
5.2	Middle Module.....	5-2
5.3	Rear Module.....	5-3
5.4	Drive Assembly.....	5-4
5.5	Legs.....	5-5
5.6	Decals.....	5-6

## SECTION 1 SAFETY INSTRUCTIONS

### 1.1 Safety Symbols

The following symbols and signal words call your attention to instructions concerning your personal safety. Be sure to observe and follow these instructions.



The word **DANGER** indicates an imminently hazardous situation which, if not avoided, will result in death or serious injury.



**WARNING!** suggests a potentially hazardous situation which, if not avoided, could result in death or serious injury.



**CAUTION** refers to potentially hazardous situations which, if not avoided, may result in minor or moderate injury to persons or equipment.



**IMPORTANT!** indicates vital information.

**NOTE:** gives helpful information.



Warning stripes are placed on areas where a single decal would be insufficient. To avoid serious injury, keep out of the path of any equipment marked with warning stripes.

# 1 Safety Instructions

## *Safety Instructions*

---

## 1.2 Safety Instructions

**NOTE:** ONLY safety instructions regarding personal injury are listed in this section. Caution statements regarding only equipment damage appear where applicable throughout the manual.

### *Observe Safety Instructions*



**IMPORTANT!** Read the entire Operator's Manual before operating the unit. Take notice of all safety warnings throughout this manual and those posted on the equipment. Keep this manual with this equipment at all times, regardless of ownership.

Also read any additional manufacturer's manuals and observe any applicable safety instructions including dangers, warnings, and cautions.

Only persons who have read and understood the entire operator's manual should operate this equipment. The equipment is not intended for use by or around children.



**IMPORTANT!** It is always the owner's responsibility to comply with all applicable federal, state and local laws, rules and regulations regarding the ownership, operation and towing of your Wood-Mizer equipment.



### ***Wear Safety Clothing***



**WARNING!** Secure all loose clothing and jewelry before operating this equipment. Failure to do so may result in serious injury or death.

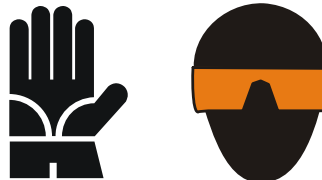

**WARNING!** Always wear eye, ear, respiration and foot protection as well as safety clothing when operating or servicing the equipment.



### ***Keep the Equipment and Area Around Clean***



**DANGER!** Maintain a clean and clear path for all necessary movement around the equipment and lumber stacking areas. Failure to do so may result in serious injury.

### ***Dispose Of Sawing By-Products Properly***



**IMPORTANT!** Always properly dispose of all sawing by-products, including sawdust and other debris.

***Check the Equipment Before Operation***

**DANGER!** Make sure all guards and covers are in place and secured before operating the equipment. Failure to do so may result in serious injury.

***Keep Persons Away***

**DANGER!** Keep all persons out of the path of moving equipment and lumber when operating the equipment. Failure to do so may result in serious injury.



**DANGER!** Be sure that all persons are away from the equipment before starting it. Failure to do so may result in serious injury.

***Keep Hands Away***

**DANGER!** Always keep hands away from moving chain. Failure to do so may result in serious injury.



**DANGER!** Always be aware of and take proper protective measures against rotating shafts, pulleys, fans, etc. Always stay a safe distance from rotating members and make sure that loose clothing or long hair does not engage rotating members resulting in possible injury.



### *Use Proper Maintenance Procedures*



**DANGER!** Make sure all electrical installation, service and/or maintenance work is performed by a qualified electrician and is in accordance with applicable electrical codes.



**DANGER!** Hazardous voltage inside the electric box and at the motor can cause shock, burns, or death. Disconnect and lock out power supply before servicing! Keep all electrical component covers closed and securely fastened during equipment operation.



**WARNING!** Consider all electrical circuits energized and dangerous.



**WARNING!** Disconnect and lock out power supply before servicing! Failure to do so may result in serious injury.



**WARNING!** Never assume or take the word of another person that the power is off; check it out and lock it out.



**WARNING!** Do not wear rings, watches, or other jewelry while working around an open electrical circuit.





**CAUTION!** The conveyor's work-stand should be equipped with a 4 kg or bigger dry powder extinguisher.

# 1 Safety Instructions

*Keep Safety Labels In Good Condition*

## Keep Safety Labels In Good Condition

 **IMPORTANT!** Always be sure that all safety decals are clean and readable. Replace all damaged safety decals to prevent personal injury or damage to the equipment. Contact your local distributor, or call your Customer Service Representative to order more decals.

 **IMPORTANT!** If replacing a component which has a safety decal affixed to it, make sure the new component also has the safety decal affixed.

## Safety Labels Description

See Table 1-1. Pictographic safety labels are shown in the table below.

**TABELA 1-1**





Decal View	Decal No.	Description
	096317	Read thoroughly the operator's manual before operating the equipment. Observe instructions and safety rules when operating.
	099220	Close all guards and covers prior to starting the equipment.

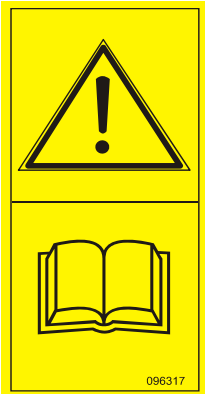

TABELA 1-1

 <p>099221</p>	<p>099221</p>	<p>Keep all persons a safe distance away from work area when operating the unit.</p>
 <p>096314</p>	<p>096314</p>	<p>Keep all persons a safe distance away from work area when operating the unit.</p>
 <p>096316</p>	<p>096316</p>	<p>Do not open or close the electric box when the switch is not in the "0" position.</p>

# 1 Safety Instructions

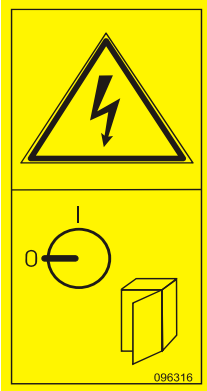
## Safety Labels Description

TABELA 1-1







	<p>096319</p>	<p>Disconnect power supply before opening the box.</p>
	<p>098177</p>	<p>Disconnect power supply before servicing.</p>
	<p>099540</p>	<p>CAUTION! Gear danger – keep a safe distance away!</p>

TABELA 1-1

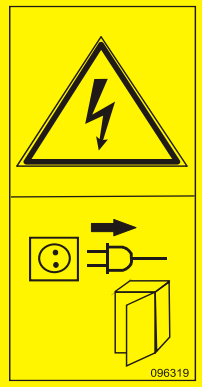
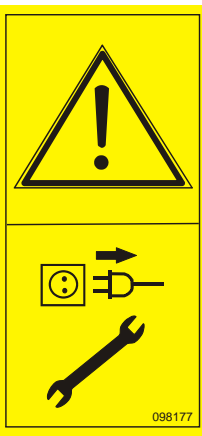
	<p>S12004G</p>	<p>Always wear safety goggles when operating the equipment.</p>
	<p>S12005G</p>	<p>Always wear protective ear muffs when operating the equipment.</p>
	<p>P85070</p>	<p>CE safety certification</p>
	<p>099780</p>	<p>Caution! Slabs falling off the deck!</p>



## **Safety Instructions**

*Safety Labels Description*

---

## SECTION 2 OPERATION

### 2.1 Transfer Deck Components

 **WARNING!** Always stay a safe distance from moving equipment and boards while operating the transfer deck. Failure to do so may result in serious injury or death.

The major components of the Horizontal Cross Transfer Deck are shown below.

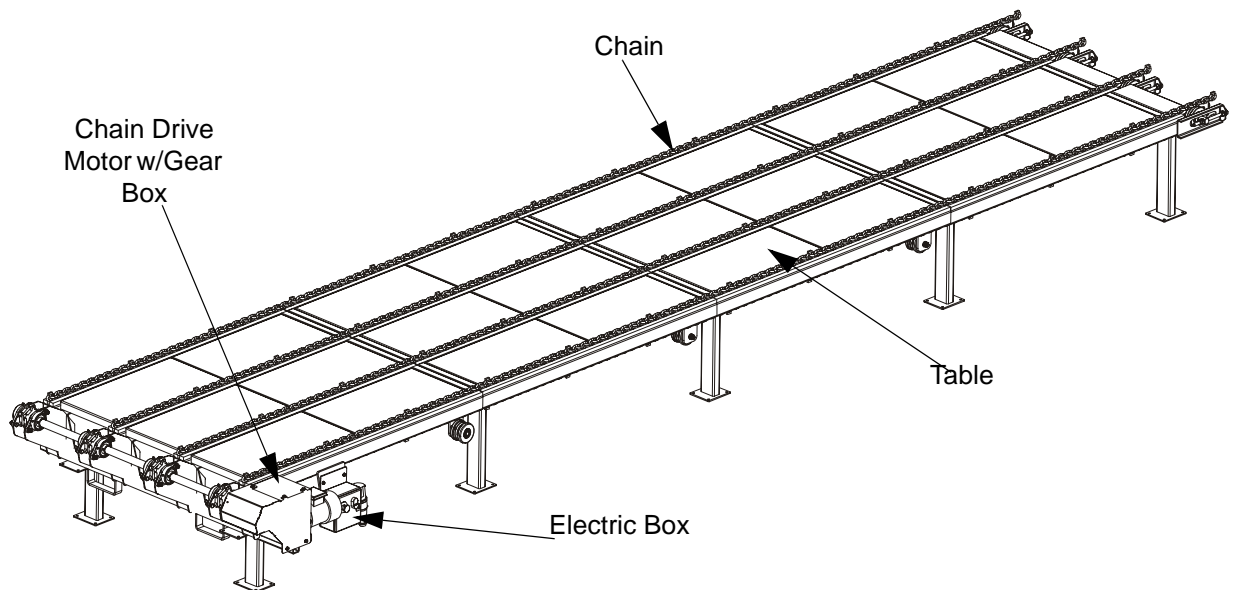

**FIG. 2-1 HORIZONTAL CROSS TRANSFER DECK**

### 2.2 Transfer Deck Setup

 **IMPORTANT!** Before starting to use the transfer deck you have to meet the following conditions:

- Set up the deck on firm and level ground. Fasten the unit to the ground.
- The transfer deck can be operated in temperature range from  $-20^{\circ}\text{C}$  to  $40^{\circ}\text{C}$  only.
- The operator's position is shown in the figure below.

## 2 OPERATION

### Transfer Deck Setup

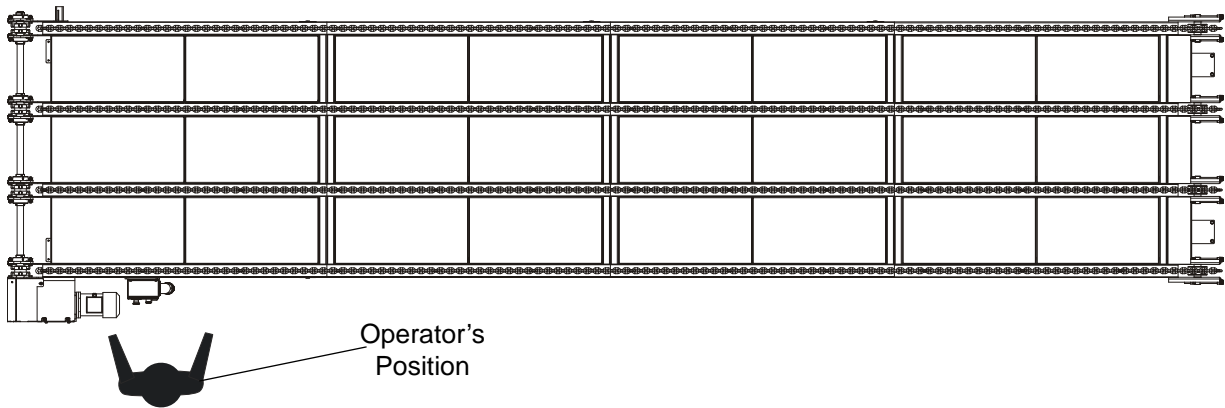

- Have a qualified electrician install the power supply (according to EN 60204 Standard). The power supply must meet the specifications given in the table below.

3-Phase Volts	Fuse Disconnecter	Recommended Wire Size
400 VAC	4 Amp	1.5 mm <sup>2</sup>

TABLE 2-1



**IMPORTANT!** When starting the unit for the first time, check that the chain rotation direction is correct. If it is incorrect, invert the phases in the phase inverter located in the power socket (in the electric box).

**IMPORTANT!** When starting the equipment for the first time, let it run without load for the first 1-2 hours.

- The transfer deck can be lifted with a forklift only. The forklift should be rated for at least 1000-1500kg. The figure below shows a Horizontal Cross Transfer Deck

prepared for towing.



**FIG. 2-1**



**CAUTION!** Since the transfer deck is long, it can be moved and transported in modules only. Disassemble the transfer deck before transportation.

## **2** OPERATION

### *Transfer Deck Operation*

---

### 2.3 Transfer Deck Operation

Use the START/STOP button on the electric box to turn on/off the Cross Transfer Deck. In case of any danger to persons or equipment, push the emergency stop button. This stops the transfer deck and the TVS. To release the stop, turn the emergency stop button clockwise. The machine will not restart until the emergency stop is released.

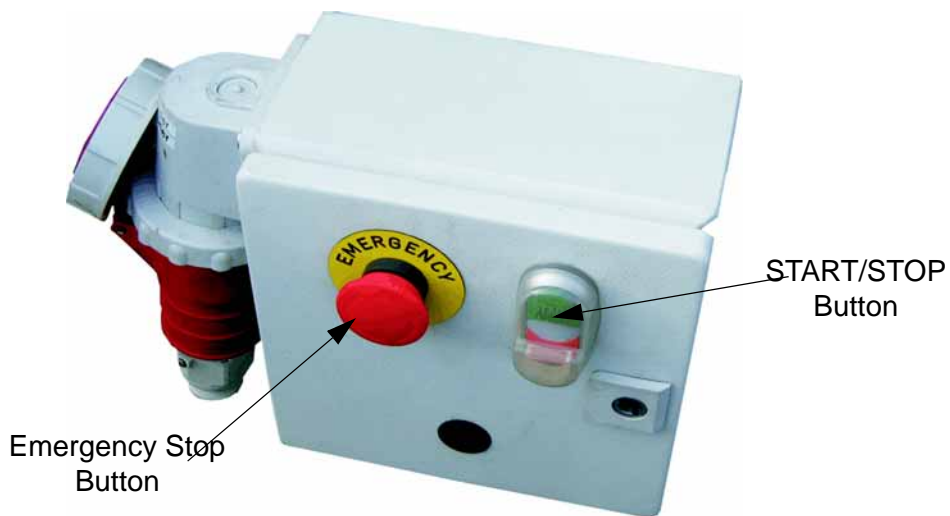

**FIG. 2-1**



**CAUTION!** If at any time you need to immediately stop the chain drive motor, press the emergency stop button located on the electric box.



## SECTION 3 MAINTENANCE

This section lists the maintenance procedures that need to be performed..

 **This symbol** identifies the interval (hours of operation) at which each maintenance procedure should be performed.

### 3.1 Lubrication

 **CAUTION!** Never apply grease to the transfer chain. It causes sawdust buildup in chain links.

-  Using the grease fittings, lubricate the drive shaft bearings every 50 hours of operation.

See Figure 3-1.

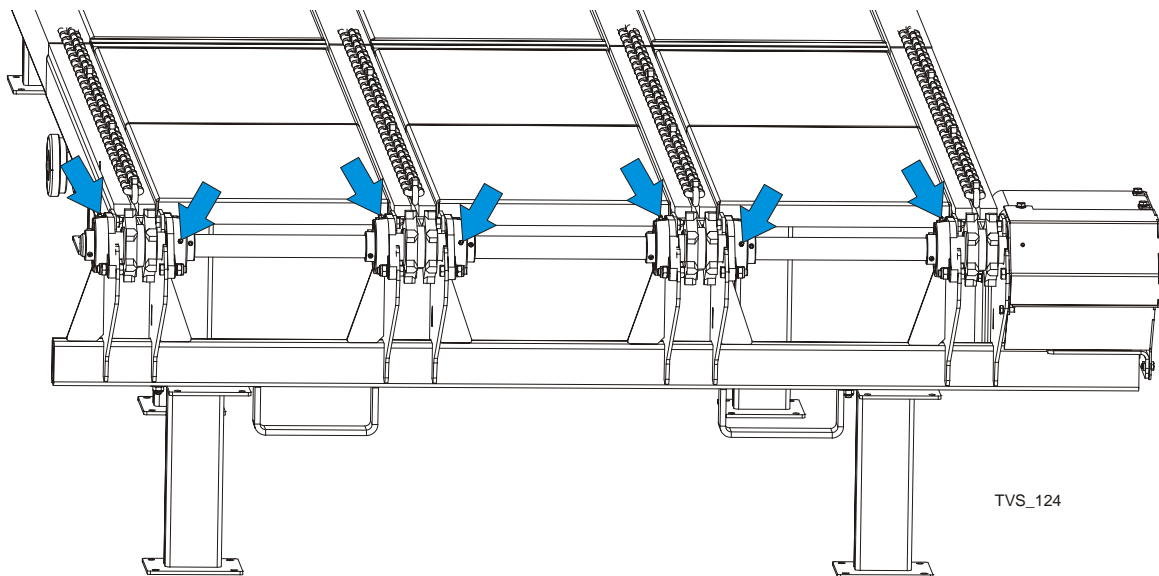

**FIG. 3-1**

- Make sure all safety warning decals are readable. Remove sawdust and dirt. Replace any damaged or unreadable decals immediately. Order decals from your Wood-Mizer Customer Service Representative.

## 3.2 Transfer Chain Tension

See **Figure 3-2**. Use the adjustment bolts shown below to adjust the transfer chain tension as necessary. The chain should lie freely on the guide bars.

**CAUTION!** Do not overtension chains of the TVS, the Log Deck and the Cross Transfer Decks. Overtensioning may lead to premature failure of the gears, bearings, rollers and chains.

See **Figure 3-3**. Adjust the transfer chain tension so that the chain lies freely on the support rollers.

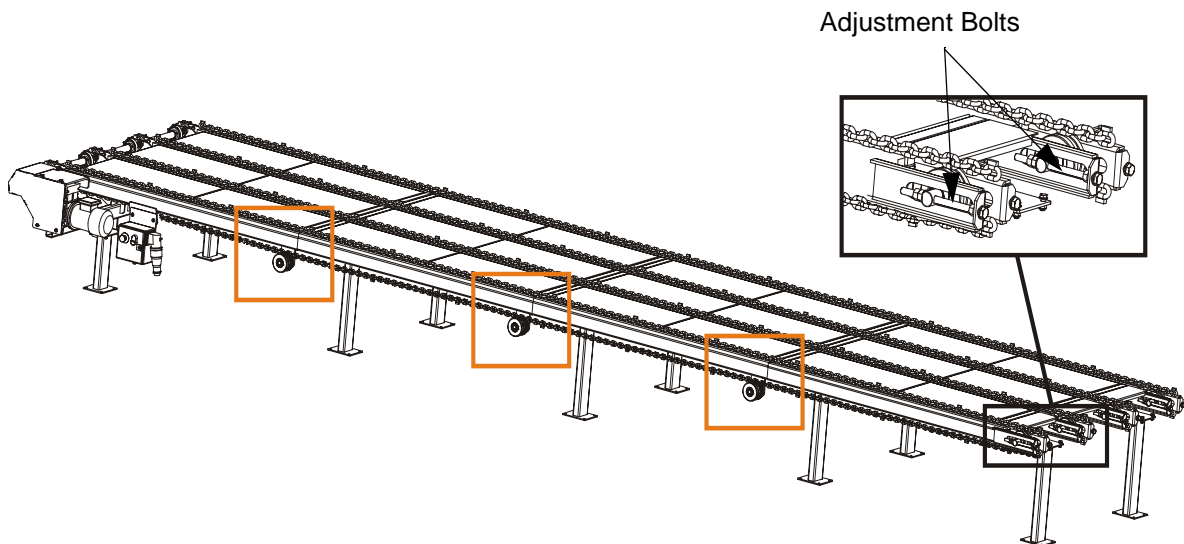
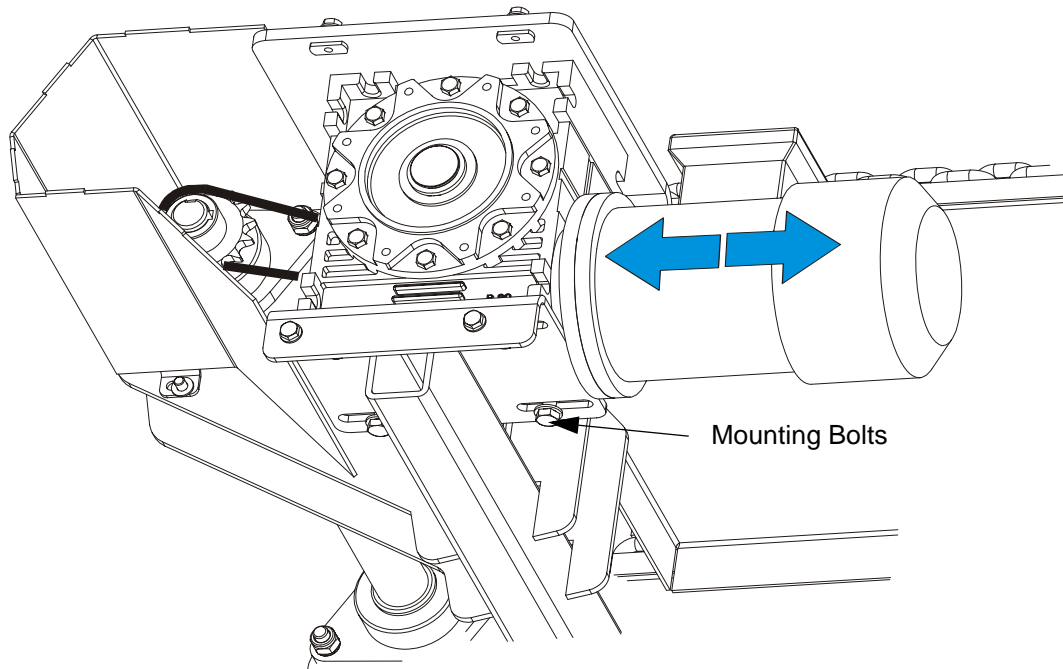

**FIG. 3-3**

### 3.3 Drive Chain Tension

Check tensions of the drive chains every 40 hours of operation and adjust as necessary. The chains should have approximately 1.5 cm of slack.

**See Figure 3-4.** Loosen the mounting bolts and move the motor along with the mounting plate in the direction indicated by the arrows.



**FIG. 3-4**

# 4 SPECIFICATIONS

## Transfer Deck Dimensions

### SECTION 4 SPECIFICATIONS

#### 4.1 Transfer Deck Dimensions

See Figure 4-1. The overall dimensions of the SLPHCTD transfer deck are shown below (all dimensions are in millimeters).

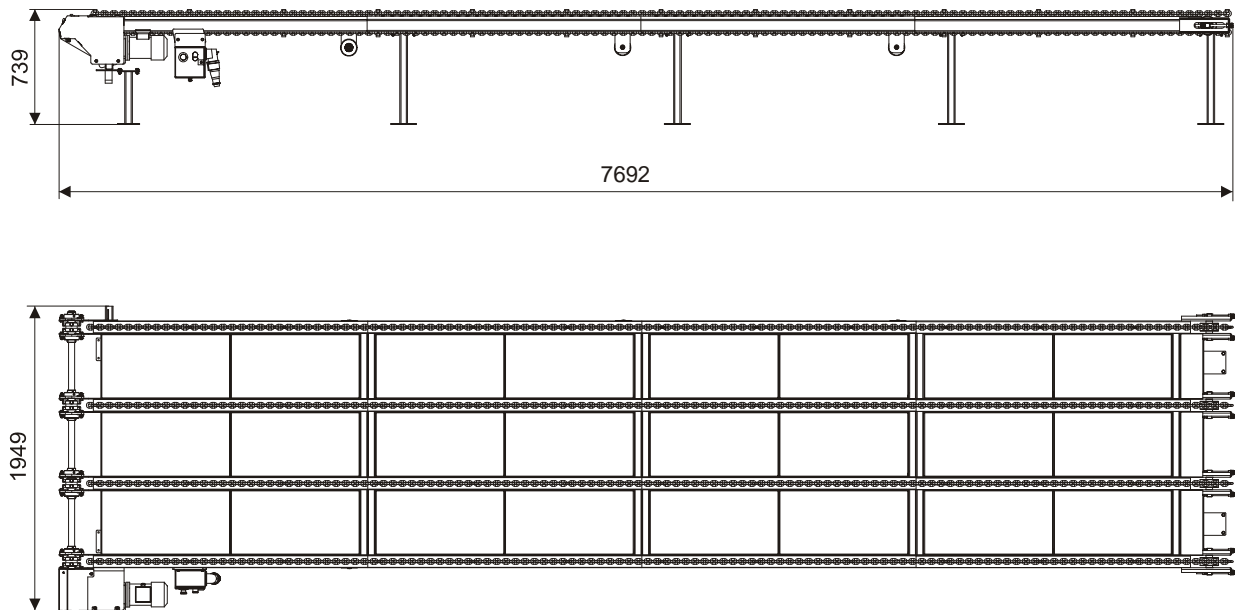

FIG. 4-1

See Table 4-1. See the table below for the weight of your transfer deck.

Transfer Deck Type	Weight
SLPHCTD	600 kg

TABLE 4-1

See Figure 4-2. The overall dimensions of the SLPHCTD Cross Transfer Deck are shown below (all dimensions are in millimeters).

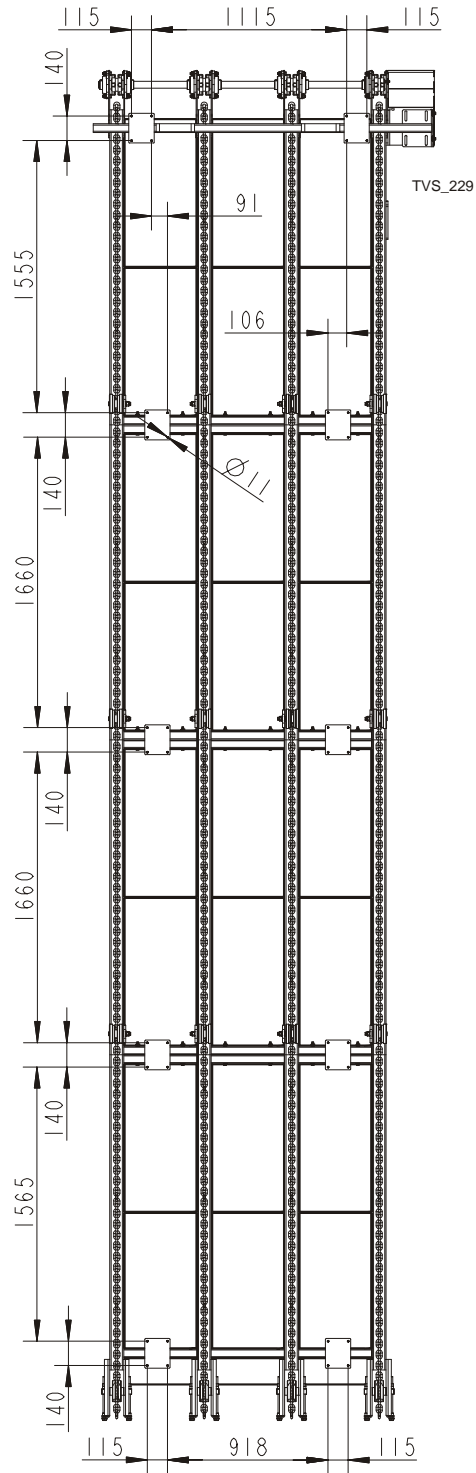

**FIG. 4-2 SLPHCTD**

# 4 SPECIFICATIONS

## Motor Specifications

### 4.2 Motor specifications

See Table 4-2. The specifications of the chain drive motor are listed below.

Motor Type	Manufacturer	Power	Other data
SKh80X-4C1	Besel	1.1kW	1380 r.p.m. 3x230/400V, 50Hz

TABLE 4-2

### 4.3 Electrical Diagram

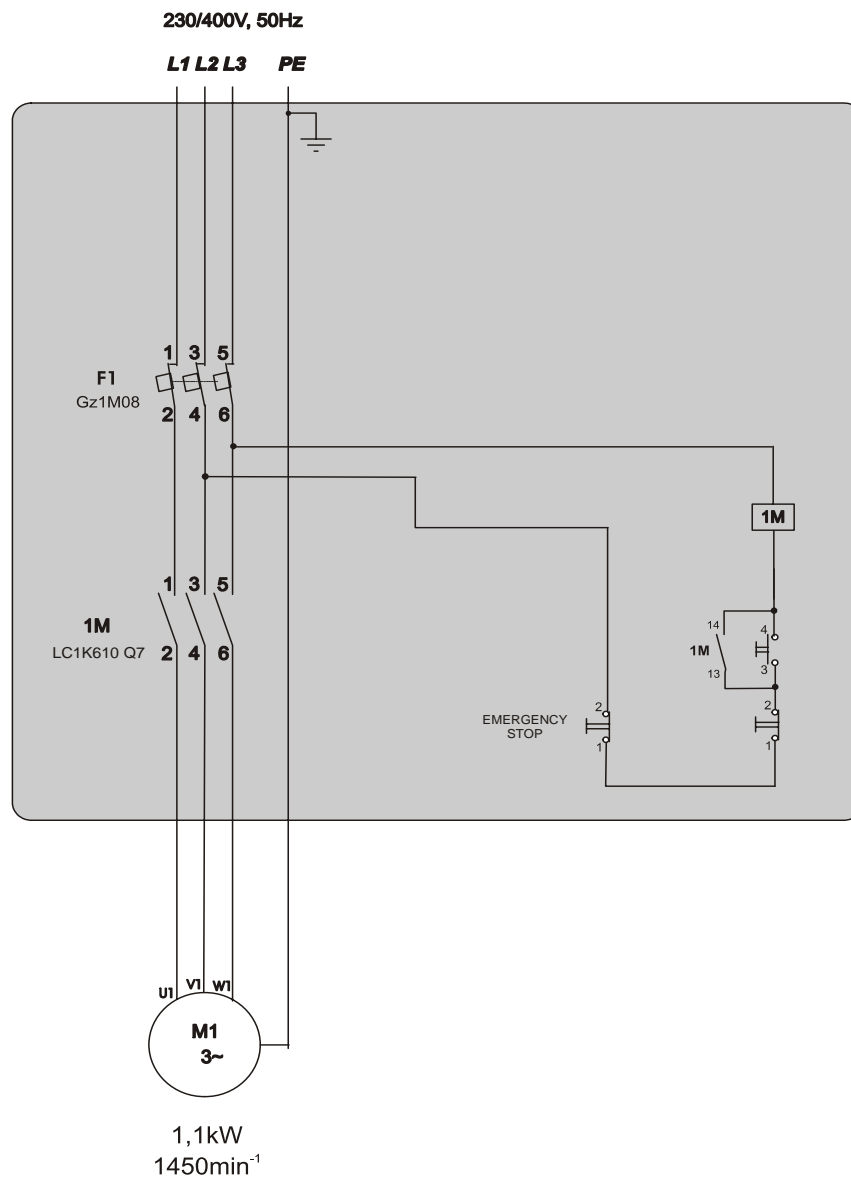

FIG. 4-2

#### 4.4 Electrical Components List

Symbol	Wood-Mizer No.	Opis
<b>GZ</b>	083659	Switch, Gz1 M08 Motor Disconnect
<b>1M</b>	094805	Contactora, LC1K0610 Q7
	089802	Housing, Rittal EB1549500 200x200x120
	E85239	Plug, 16A 5P, Power
	E85240	Socket, 16A
	090452	Switch, M22 START-STOP
	086556	Switch, XB4BS542 Emergency Stop

**TABLE 4-3**

## SECTION 5 REPLACEMENT PARTS

## 5.1 Front Module &amp; Chains

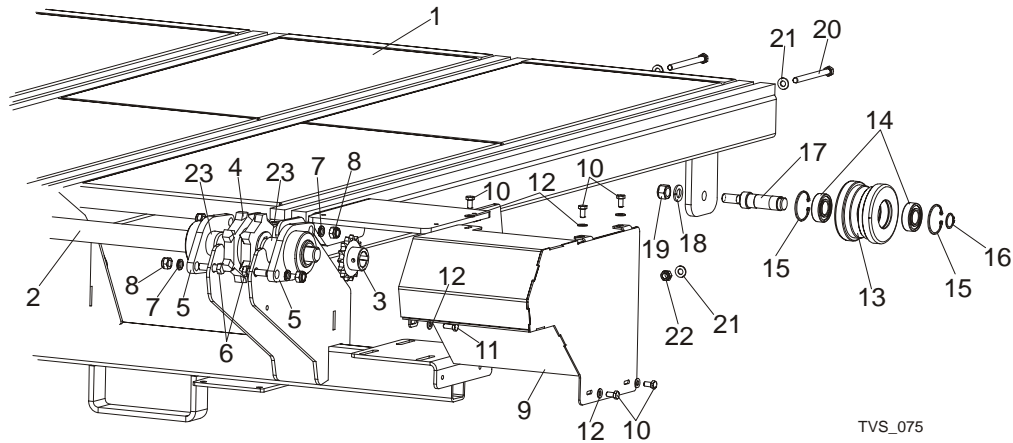

REF	DESCRIPTION (◆ Indicates Parts Available In Assemblies Only)	PART #	QTY.
	<b>COMPLETE FRONT MODULE</b>	<b>099556</b>	1
1	FRAME WELDMENT, CTD FRONT	097899-1	1
2	SHAFT, CTD DRIVE	097893	1
3	SPROCKET, 10B Z 15	095162	1
4	SPROCKET, 16B 20Z	097657	4
5	BEARING, FYTB 40 KG	097898	8
6	BOLT, M12x40-8.8 HEX HEAD ZINC	F81004-1	16
7	WASHER, Z12.2 SPLIT LOCK ZINC	F81056-2	16
8	NUT, M12-8 HEX NYLON ZINC LOCK	F81034-2	16
9	COVER WELDMENT, CTD CHAIN PTD	097903-1	1
10	BOLT, M8x16 -8.8-B HEX HEAD FULL THREAD ZINC	F81002-20	5
11	BOLT, M8x20-8.8-B HEX HEAD FULL THREAD ZINC	F81002-4	1
12	WASHER, 8.4 FLAT ZINC	F81054-1	6
	WHEEL, CTD COMPLETE	098492	4
13	TENSIONER, CTD CHAIN	098493	1
14	BEARING, 6205.2RSR FAG	087353	2
15	RING, W52 INSIDE RETAINING	F81090-6	2
16	RING, 25Z OUTSIDE RETAINING	F81090-22	1
17	SHAFT, CTD CHAIN TENSIONER	098494	1
18	WASHER, 16.3 SPLIT LOCK ZINC	F81058-2	4
19	NUT, M16-8 HEX NYLON ZINC LOCK	F81036-2	4
20	BOLT, M10x125-8.8 HEX HEAD ZINC	F81003-18	6
21	WASHER, 10.5 FLAT ZINC	F81055-1	12
22	NUT, M10-8-B HEX NYLON ZINC LOCK	F81033-1	6
23	BUSHING, FI 40 x FI 48x14 SPACER	099958-1	8
	<b>CHAIN, CTD 7.2</b>	<b>099572</b>	4



5.2 Middle Module

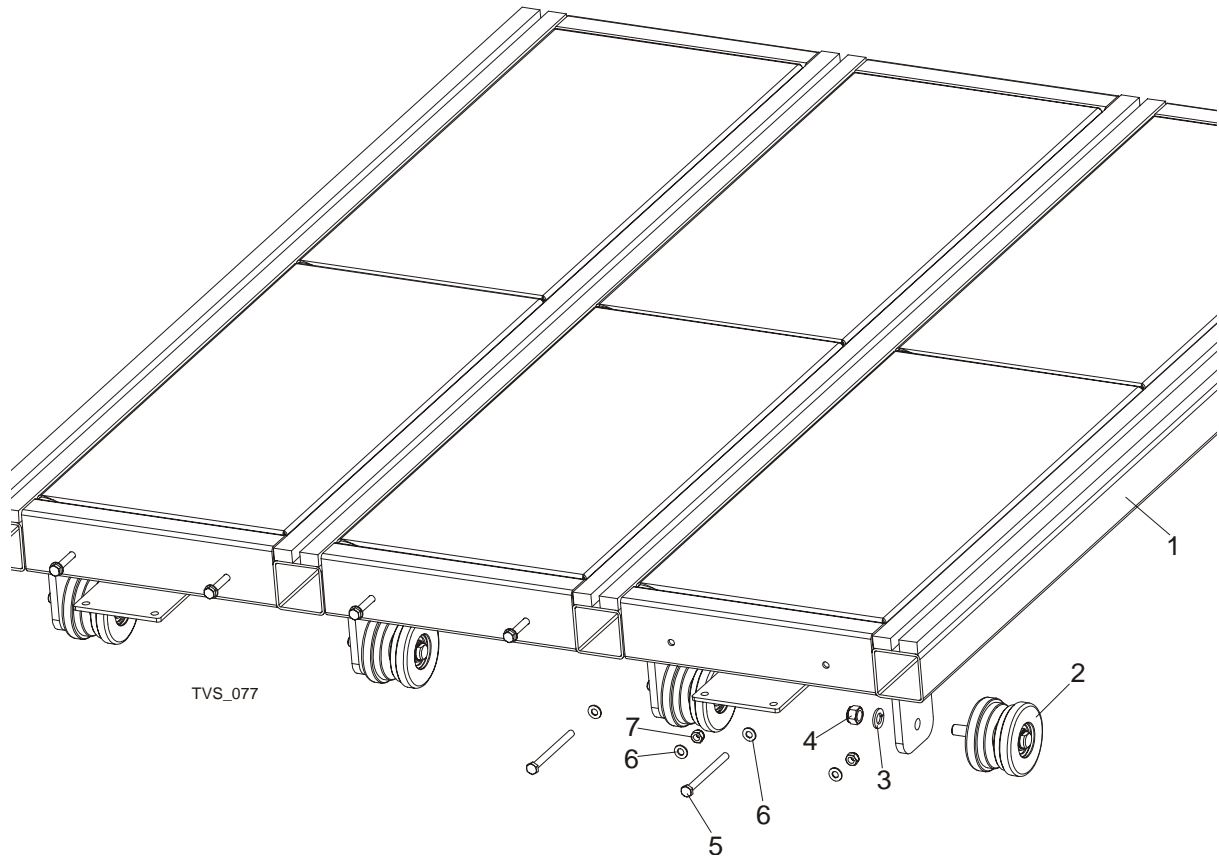

REF	DESCRIPTION (◆ Indicates Parts Available In Assemblies Only)	PART #	QTY.
	<b>COMPLETE MIDDLE MODULE</b>	<b>099557</b>	2
1	MODULE, CTD MIDDLE PAINTED	098125-1	1
2	WHEEL, CTD COMPLETE	098492	4
3	WASHER, 16.3 SPLIT LOCK ZINC	F81058-2	4
4	NUT, M16-8 HEX NYLON ZINC LOCK	F81036-2	4
5	BOLT, M10x125-8.8 HEX HEAD ZINC	F81003-18	6
6	WASHER, 10.5 FLAT ZINC	F81055-1	12
7	NUT, M10-8-B HEX NYLON ZINC LOCK	F81033-1	6

## 5.3 Rear Module

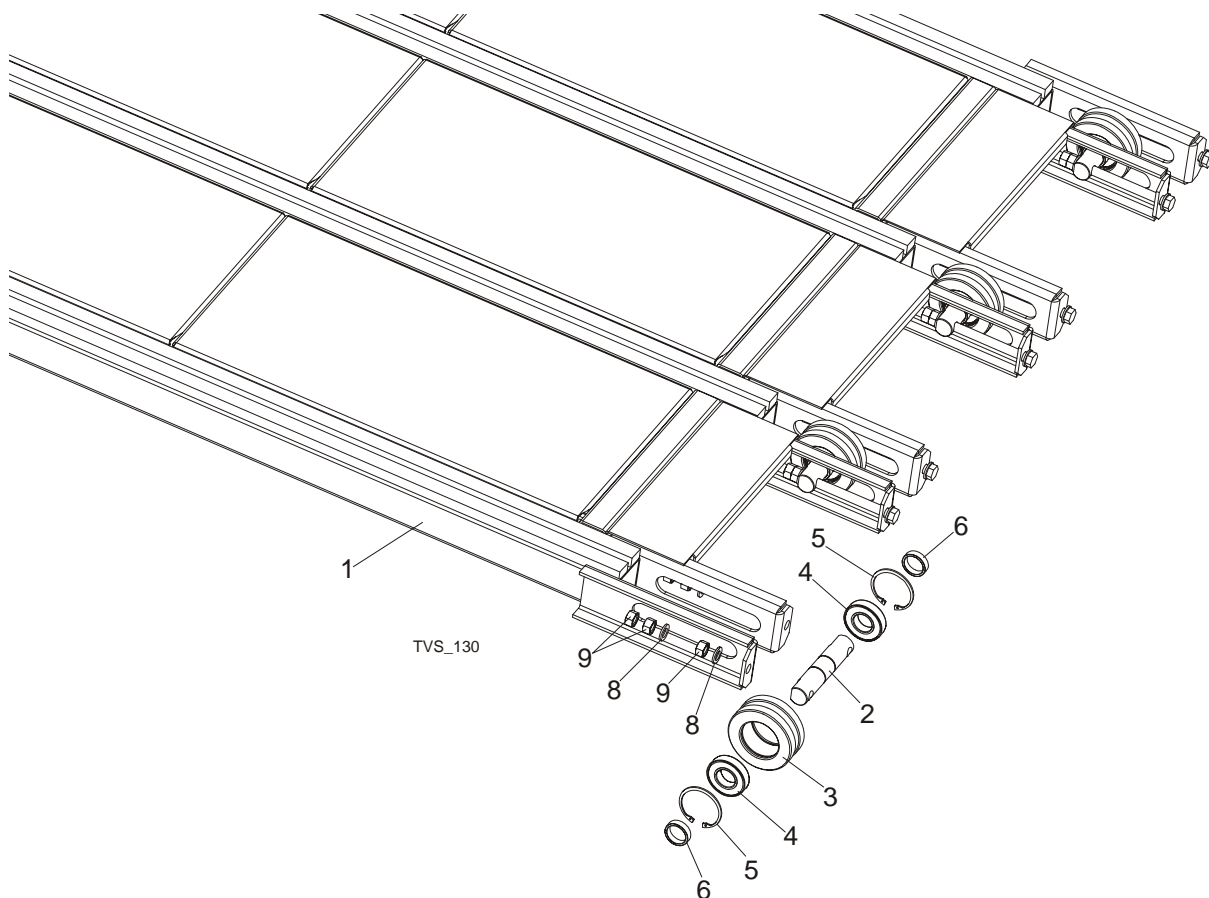

REF	DESCRIPTION (◆ Indicates Parts Available In Assemblies Only )	PART #	QTY.
	<b>COMPLETE REAR MODULE</b>	<b>099558</b>	<b>1</b>
1	FRAME WELDMENT, CTD REAR PTD	097900-1	1
	<b>COMPLETE CHAIN TENSION WHEEL</b>	<b>097655</b>	<b>4</b>
2	SHAFT, CHAIN TENSION WHEEL	096207-1	1
3	WHEEL, TVS CHAIN TENSION	096208-1	1
4	BEARING, 6207-2RS, C3, 35X72X17	014811	2
5	RING, W72 INSIDE RETAINING	F81090-4	2
6	BUSHING, FI 36x FI 44x22 SPACER ZINC	099959-1	8
7	BOLT, M16X240-8.8-A2 FULL THREAD	F81006-29	8
8	WASHER, 17 FLAT ZINC	F81058-1	24
9	NUT, M16-5.8 HEX ZINC	F81036-1	24

5.4 Drive Assembly

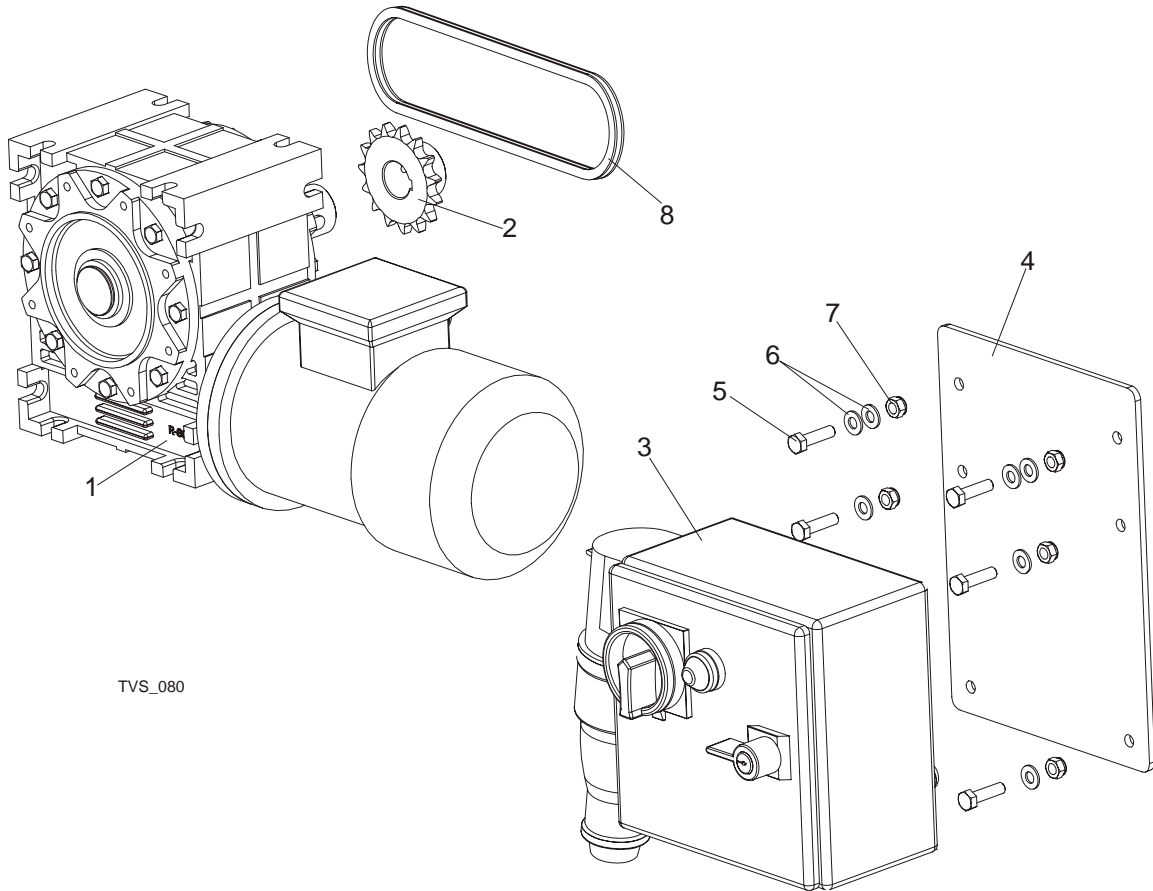

TVS\_080

REF	DESCRIPTION (◆ Indicates Parts Available In Assemblies Only )	PART #	QTY.
	<b>MOTOR KIT</b>	<b>099559</b>	1
1	MOTOREDUCER, MR-80/64-1.1-1400/K3/V6	098663	1
2	SPROCKET, 10B Z 15 INCLINE CONVEYOR	095162	1
3	BOX, CTD ELECTRIC	098826	1
4	PANEL, CTD ELECTRIC BOX	099550-1	1
5	BOLT, M8X30-5.8 HEX HEAD FULL THREAD ZINC	F81002-2	6
6	WASHER, 8.4 FLAT ZINC	F81054-1	8
7	NUT, M8-8-B HEX NYLON ZINC LOCK	F81032-2	6
8	CHAIN, 10B-48PZ	099781	1

**5.5 Legs**

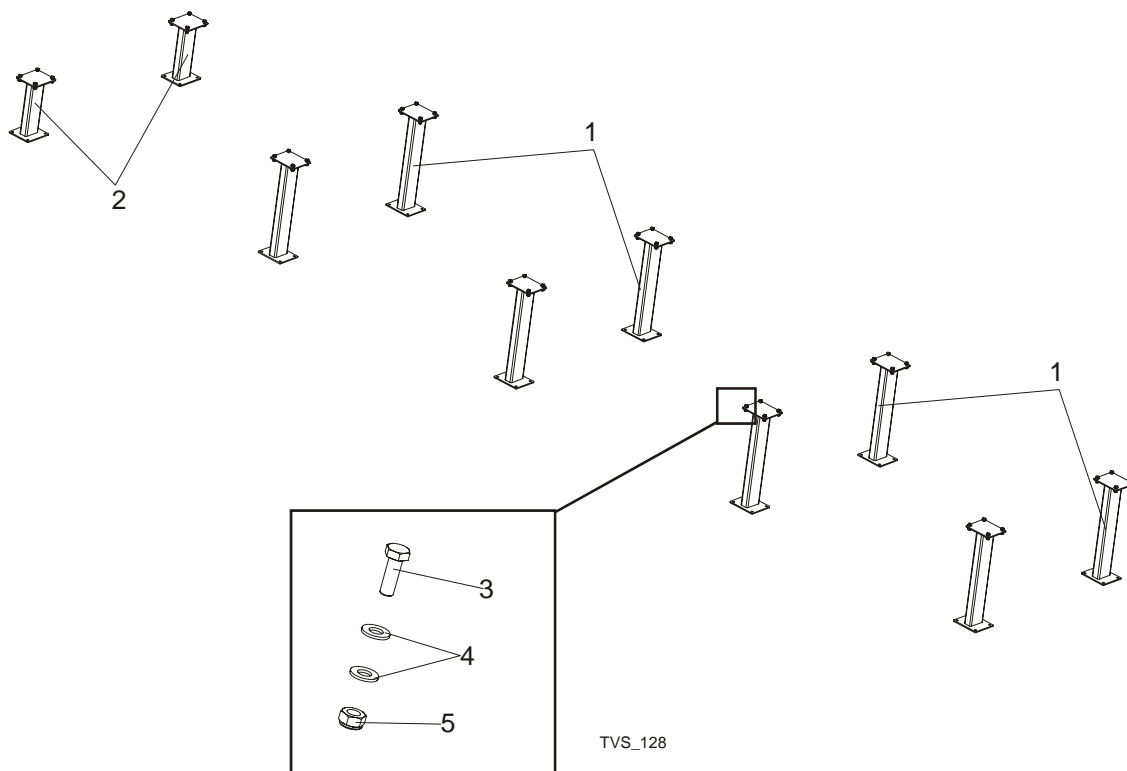

REF	DESCRIPTION (◆ Indicates Parts Available In Assemblies Only)	PART #	QTY.	
	<b>LEG KIT, SLPHCTD</b>	<b>099552</b>	1	
<b>1</b>	LEG, SLPHCTD	<b>099193-1</b>	8	
<b>2</b>	LEG, SLPHCTD FRONT	<b>099276-1</b>	2	
<b>3</b>	BOLT, M10x30-5.8 HEX HEAD FULL THREAD ZINC	<b>F81003-2</b>	40	
<b>4</b>	WASHER, 10.5 FLAT ZINC	<b>F81055-1</b>	80	
<b>5</b>	NUT, M10-8-B HEX NYLON ZINC LOCK	<b>F81033-1</b>	40	

5.6 Decals

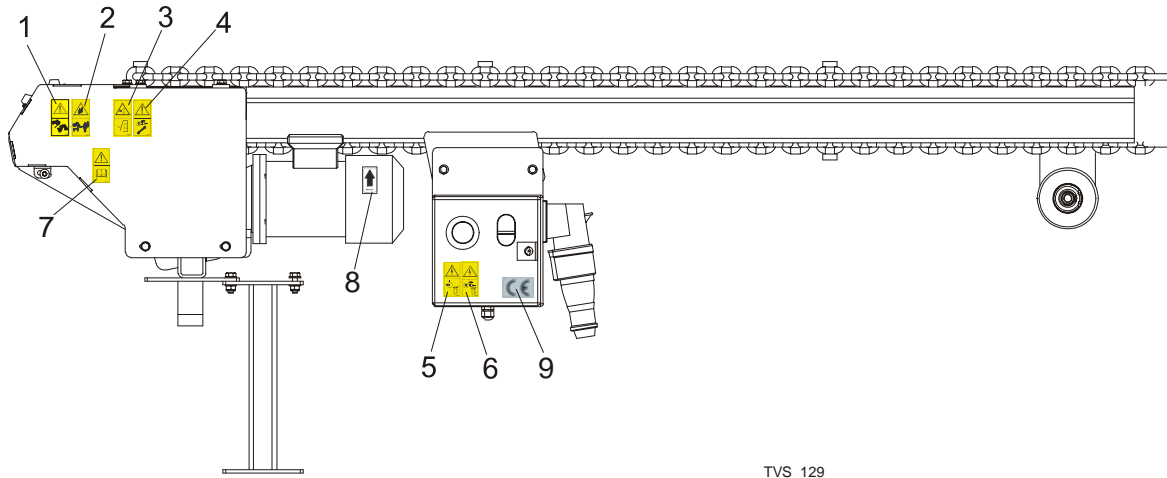

TVS\_129

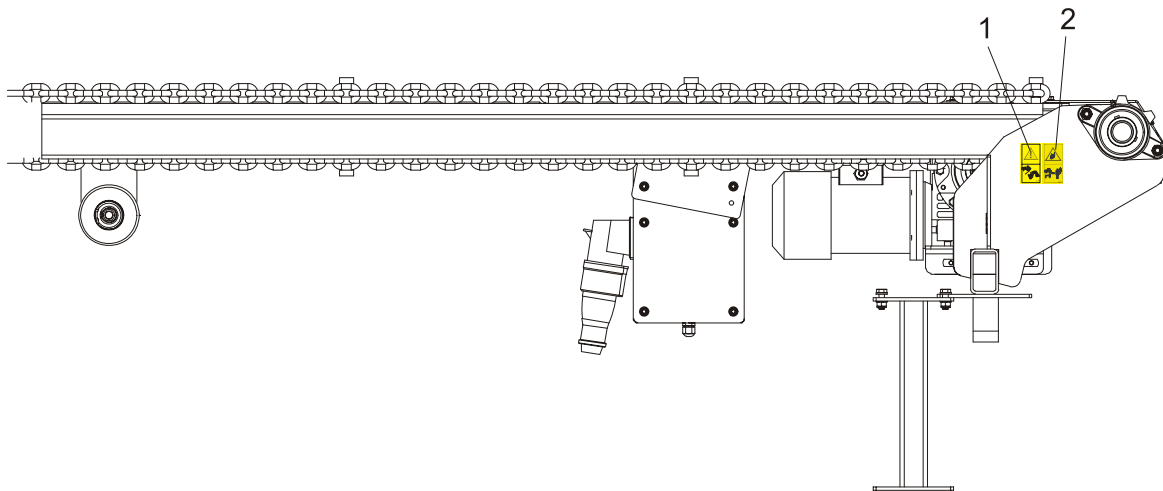

REF	DESCRIPTION (◆ Indicates Parts Available In Assemblies Only )	PART #	QTY.
	<b>DECALS KIT, PICTOGRAMS, CROSS TRANSFER DECK</b>	<b>099835</b>	1
1	Decal, look out for the falling slabs (pictogram)	099780	2
2	Decal, keep away warning (pictogram)	099221	2
3	Decal, close all guards and covers before starting the machine	099220	1
4	Decal, disconnect and lock out power supply before servicing (pictogram)	098177	1
5	Decal, high voltage inside the electric box (pictogram)	096316	1
6	Decal, remove the plug before opening the box (pictogram)	096319	1
7	Decal, read operator's manual (pictogram)	096317	1
8	Decal, 1400 RPM Motor Direction	S20097H	1
9	<b>DECAL, CE - CERTIFIED SAWMILL</b>	<b>P85070</b>	1



## EC declaration of conformity according to EC Machinery Directive 2006/42/EC

We herewith declare,

Wood-Mizer Industries sp. Z O.O.  
114 Nagorna street, 62-600 Kolo; Poland.

That the following described machine in our delivered version complies with the appropriate basic safety and health requirements of the EC Machinery Directive 2006/42/EC based on its design and type, as brought into circulation by us. In case of alteration of the machine, not agreed by us, this declaration is no longer valid.

Designation of the machine: **Cross Transfer Deck (SLPCTD)**

TYPE: **SLPCTD.....**

No. of manufacturer: .....

Applicable EC Directives: EC Machinery Directive 2006/42/EC  
EC Low-Voltage Directive 73/23/EEC  
EC Electromagnetic Compatibility Directive  
2004/108/EC

Responsible for Technical Documentation: Roman Frontczak / R&D Director

Date/Authorized Signature: 29. 12. 2009 

Title : R&D Director