



## user manual

Instrukcja obsługi | Руководство пользователя  
Manuel de l'Utilisateur | Betriebsanweisung  
Bruksanvisning | Manual del Usuario  
Betjeningsvejledning | Gebruikershandleiding  
Käyttöohjeet | Manual de utilizare | Bruksanvisning  
Manuale d'uso | Příručka uživatele | Navodila  
za uporabo

Retain for future use  
Zachować do przyszłego użytku  
Сохраните для последующего  
использования  
A conserver pour une utilisation future  
Für zukünftige Benutzung aufbewahren  
Behold for senere bruk  
Säilytä nämä käyttöohjeet tulevaa tarvetta marten  
Opbevar manualen til fremtidig brug  
Bewaren voor gebruik in de toekomst  
Conservare il presente manuale a l'uso futuro  
Păstrați acest manual pentru utilizare viitoare  
Conservar para futuras consultas  
Behall för framtida användning  
Uchovejte pro další použití  
Hranite za prihodnjo uporabo



# Edger Multi-Rip

## Safety, Operation, Maintenance & Parts Manual

---

<b>EG250E15-EMR</b>	<b>rev. A2.02</b>
<b>EG250E20-EMR</b>	<b>rev. A2.02</b>
<b>EG300E20S-EMR</b>	<b>rev. B2.02</b>
<b>(EE20S-EMR)</b>	
<b>EG300E25S-EMR</b>	<b>rev. B2.02</b>
<b>(EE25S-EMR)</b>	
<b>EG300EC25U (USA)</b>	<b>rev. B3.00</b>

---



**Safety is our #1 concern!** Read and understand all safety information and instructions before operating, setting up or maintaining this machine.

*Form #907*

*General Contact Information*  
*Branches & Authorized Sales Centers Wood-Mizer Locations (North and South America)*

<b>SECTION 1</b>	<b>SERVICING THE EDGER</b>	<b>1-1</b>
1.1	General Information.....	1-1
1.2	Customer and Edger Identification .....	1-1
1.3	Edger Components.....	1-3
<b>SECTION 2</b>	<b>SAFETY</b>	<b>2-1</b>
2.1	Safety Symbols .....	2-1
2.2	Safety Instructions .....	2-1
	<i>Observe Safety Instructions</i>	
	<i>Wear Safety Clothing</i>	
	<i>Keep Edger And Area Around Clean</i>	
	<i>Dispose Of Sawing By-Products Properly</i>	
	<i>Check Edger Before Operation</i>	
	<i>Keep Persons Away</i>	
	<i>Keep Hands Away</i>	
	<i>Use Proper Maintenance Procedures</i>	
	<i>Keep Safety Labels In Good Condition</i>	
	<b>FIRE-FIGHTING</b>	
	<i>Safety Labels Description</i>	
<b>SECTION 3</b>	<b>OPERATION</b>	<b>3-1</b>
3.1	Pre-Operation Check.....	3-1
3.2	Control Overview.....	3-5
	<b>Control Panel, EG300</b>	
	<b>Control Panel, EG250</b>	
3.3	..... Edger Setup	3-8
3.4	Machine Start.....	3-13
3.5	Blade Installation .....	3-18
	<i>Multirip Option</i>	
	<i>Additional Fixed Blade Option</i>	
3.6	Edging Lumber .....	3-23
<b>SECTION 4</b>	<b>SETWORKS OPERATION (EG300 CE ONLY)</b>	<b>4-1</b>
4.1	Edger Controller Panel.....	4-1
4.2	Start-up settings of the controller.....	4-2
4.3	Operation, Memory Buttons (A, B, C, D, E) .....	4-5
4.4	Setworks Malfunction.....	4-7

# Table of Contents

# Section-Page

<b>SECTION 5</b>	<b>NETWORKS OPERATION (EG300 U.S. ONLY)</b>	<b>5-1</b>
5.1	Networks (Optional - U.S. Version) .....5-1	
	<i>Networks Start-up</i>	
	<i>Select Unit Of Measure</i>	
	<i>Calibrate Blades Position</i>	
	<i>Adjust Preset Values</i>	
<b>SECTION 6</b>	<b>MAINTENANCE &amp; ALIGNMENT</b>	<b>6-1</b>
6.1	Replacing the Blades .....6-1	
6.2	Tensioning the Belts .....6-6	
6.3	Tensioning the Chains .....6-7	
6.4	Checking the Rollers .....6-10	
6.5	Lubrication .....6-10	
6.6	Anti-Kickback Fingers Maintenance.....6-11	
6.7	Alignment .....6-11	
6.8	Blade Sharpening.....6-14	
6.9	Using the Blades.....6-15	
6.10	EG300 Safety Devices Inspection (CE version only) .....6-16	
6.11	EG250 Safety Devices Inspection (CE version only) .....6-24	
<b>SECTION 7</b>	<b>SPECIFICATIONS</b>	<b>7-1</b>
7.1	Overall Dimensions .....7-1	
7.2	Multirip Edger Specifications.....7-3	
7.3	Dust Extractor Specifications.....7-5	
<b>SECTION 8</b>	<b>REPLACEMENT PARTS</b>	<b>8-1</b>
8.1	How To Use The Parts List .....8-1	
8.1	Sample Assembly .....8-1	
8.2	Main Shaft Assembly .....8-2	
8.3	Spacer Mounting Kit (Optional).....8-4	
8.4	Infeed Rollers Assembly .....8-5	
8.5	Hold-Down Roller & Anti-Kickback Assembly (EG300) .....8-7	
8.6	Anti-Kickback Fingers (EG250) .....8-10	
8.7	Blade Setting Assembly .....8-11	
8.8	Laser Guide Assembly (EG300) .....8-13	
8.9	Motor Assembly .....8-16	
8.10	Control Box (EG300 CE ONLY) .....8-18	
8.11	Electric Box (EG250) .....8-20	
8.12	Table (EG300) .....8-21	
8.13	Table (Option for EG250 Edgers) .....8-23	
8.14	Board Guide Fence .....8-24	
8.15	Covers.....8-25	

## Table of Contents

## Section-Page

8.16	EG250 Edger Top Cover .....	8-27
8.17	Manual Blade Setting Assembly (EG250) .....	8-28
8.18	Sawdust Hopper (EG300 and EG250 CE Version).....	8-31
8.19	Safety Cover, EG250 E15 (CE Version).....	8-33
8.20	EG300 Edger Decals .....	8-34
8.21	EG250 Edger Decals .....	8-36
8.22	Control Box (EG300 - U.S. Only).....	8-1
8.23	Electric Box (EG300 - U.S. Only).....	8-3
<b>SECTION 9</b>	<b>DC ELECTROMAGNETIC BRAKE (CE ONLY), SIEMENS MOTORS</b>	<b>9-1</b>
9.1	Design and Principle of Operation .....	9-1
9.2	Service .....	9-2
<b>SECTION 10</b>	<b>BRAKE AIR GAP ADJUSTMENT, TAMEL MOTORS</b>	<b>10-1</b>
<b>SECTION 6</b>	<b>LASER INFORMATION</b>	<b>11-1</b>

## Getting Service

Wood-Mizer is committed to providing you with the latest technology, best quality and strongest customer service available on the market today. We continually evaluate our customers' needs to ensure we're meeting current wood-processing demands. Your comments and suggestions are welcome.

### *General Contact Information*

From Europe call your local distributor or our European Headquarters and Manufacturing Facility in Koło, Nagórna 114 St, Poland at **+48-63-2626000**. From the continental U.S., call our U.S. Headquarter 8180 West 10th St. Indianapolis, IN 46214, toll-free at **1-800-525-8100**. Ask to speak with a Customer Service Representative. Please have your machine identification number and your customer number ready when you call. The Service Representative can help you with questions about the operation and maintenance of your machine. He also can schedule you for a service call.

### Office Hours:

Country	Monday - Friday	Saturday	Sunday
Poland	7 a.m.- 3 p.m.	Closed	Closed
US	8 a.m.- 5 p.m.	8 a.m.- 12 p.m	Closed

Please have your vehicle identification number and your customer number ready when you call.

Wood-Mizer will accept these methods of payment:

- Visa, Mastercard, or Discover
- COD
- Prepayment
- Net 15 (with approved credit)



Be aware that shipping and handling charges may apply. Handling charges are based on size and quantity of order.

Technical data are subject to change without prior notice.

Actual product may differ from product images. Some illustrations show machines with optional equipment.

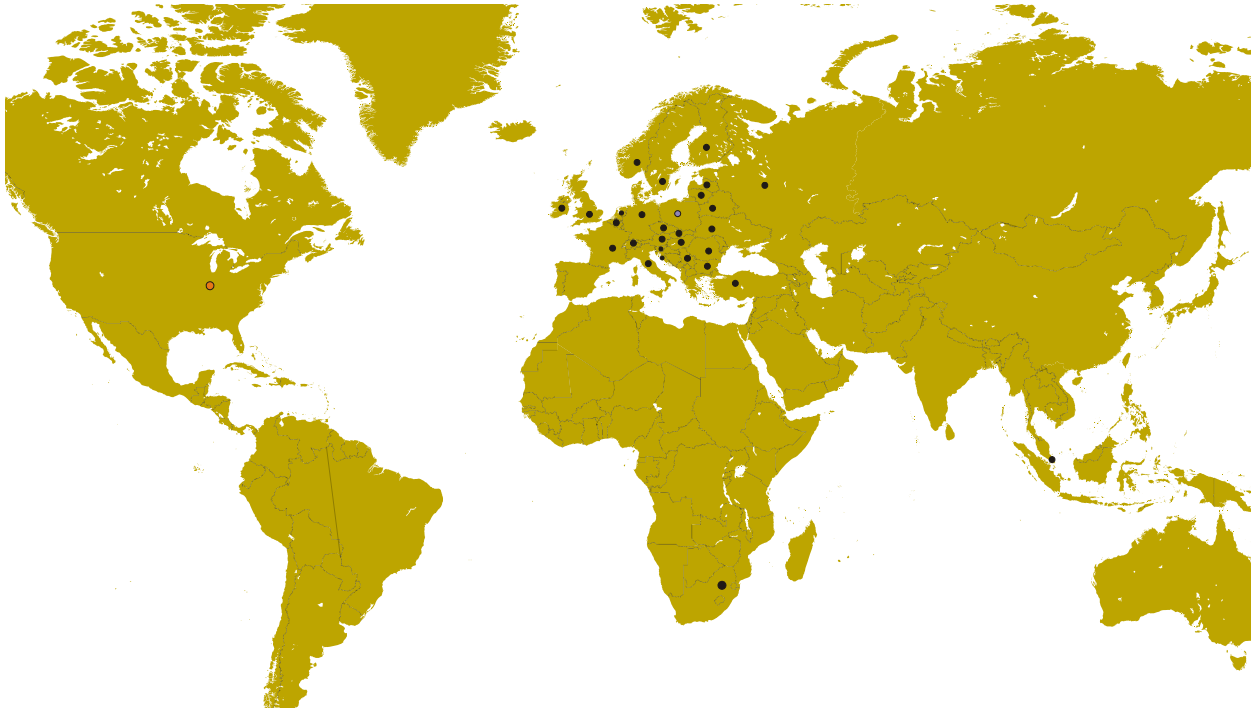
Branches & Authorized Sales Centers Wood-Mizer Locations (North and South America)



EUROPE		UNITED STATES
<p> <b>European Headquarters</b>  <b>Wood-Mizer Industries Sp. z o.o.</b>                      Nagórna 114, 62-600 Kolo, Poland                      Tel.: +48-63-26-26-000                      Fax: +48-63-27-22-327  <a href="http://www.woodmizer.eu">www.woodmizer.eu</a></p>		<p> <b>World Headquarters</b>  <b>Wood-Mizer LLC</b>                      8180 West 10th Street                      Indianapolis, Indiana 46214-2400,                      USA                      Tel.: +1-317-271-1542                      Fax: +1-317-273-1011  <a href="http://www.woodmizer.com">www.woodmizer.com</a></p>
<p><b>BELARUS</b>  <b>MOST-GRUPP</b>                      Siemashko 15, k.3                      Minsk 2200116                      Tel.: +375-17-270-90-08                      Fax: +375-17-270-90-08                      GSM: +375-29-649-90-80                      e-mail: <a href="mailto:most-by@mail.ru">most-by@mail.ru</a></p>	<p><b>SWITZERLAND Stefan Wespí</b>                      Maschinen u. Geräte                      Spezialarbeiten GmbH                      Eichstraße 4                      6353 Weggis                      Tel.: +41-(0)41 - 3900312                      GSM: +41-(0)79 - 9643594  <a href="mailto:info@mobilsaegen.ch">info@mobilsaegen.ch</a></p>	<p><b>RUSSIA Dariusz Mikołajewski</b>  <b>OOO WOOD-MIZER INDUSTRIES</b>                      141031, Moscow                      Reg., Mytishenski raj., pos. Veshki,                      Zavodskaja str., 3B                      Tel.Fax: +7(495) 788-72-35                      Tel.Fax: +7(495) 641-51-60                      e-mail: <a href="mailto:dariuszm@woodmizer-moscow.ru">dariuszm@woodmizer-moscow.ru</a></p>
<p><b>BULGARIA Kalin Simeonov</b>  <b>Ecotechproduct</b>                      38 Star Lozenski pat str.                      Sofia 1186                      Tel.: +359-2-462-7035                      Tel.: +359-2-963-1656                      Tel./Fax                      : +359-2-979-1710  <b>Kalin Simeonov</b>                      GSM: +3592-963-2559                      e-mail: <a href="mailto:office@ecotechproduct.com">office@ecotechproduct.com</a></p>	<p><b>HUNGARY Wiktor Turoczy</b>  <b>Wood-Mizer Hungary K.F.T.</b>                      Szonyi Ut 67., 2921 Komárom                      Tel./Fax: +36-34-346-255                      e-mail: <a href="mailto:woodmizer@woodmizer.hu">woodmizer@woodmizer.hu</a></p>	<p><b>RUSSIA Far East Wladimir Glazaczew</b>  <b>"WM Service"</b>                      Krasnoretschenskaya Str.111                      680006 Khabarovsk                      Tel./Fax: +7-914-541-1183                      e-mail: <a href="mailto:wms-khv@mail.ru">wms-khv@mail.ru</a></p>



<p><b>CROATIA Krešimir Pregernik Pregimex d.o.o.</b> S. Batušića 31, 10090 Zagreb Tel./Fax: +3851-38-94-668 <b>Krešimir Pregernik</b> GSM: +3851-98-207-106 e-mail: <a href="mailto:Kresimir.Pregernik@gmail.com">Kresimir.Pregernik@gmail.com</a></p>	<p><b>ITALY Pasquale Felice Wood-Mizer Italia Srl Cda. Capoiaccio SN</b> 86012 Cercemaggiore Campobasso Tel./Fax: +39-0874-798-357 GSM: +39-333-281-03-79 e-mail: <a href="mailto:wmitaliasrl@gmail.com">wmitaliasrl@gmail.com</a></p>	<p><b>SERBIA Dragan Markov Wood-Mizer Balkan d.o.o.</b> Svetosavska GA 3/3; P. Fah 25 23 300 Kikinda Tel./Fax: +381-230-25-754 Tel./Fax: +381-230-23-567 GSM: +381-63-568-658 e-mail: <a href="mailto:office@woodmizer.co.yu">office@woodmizer.co.yu</a></p>
<p><b>CZECH REPUBLIC Miroslav Greill Wood-Mizer CZ s.r.o.</b> Osvaldova 91 339 01 Klatovy-Luby Tel./Fax: +420-376-312-220 Fax: +420-376-319-011 <b>Miroslav Greill</b> GSM: +420-723-580-799 e-mail: <a href="mailto:greill@woodmizer.cz">greill@woodmizer.cz</a></p>		<p><b>SLOVAKIA Wiktor Turoczy Wood-Mizer Danubia s.r.o.</b> Hadovce 5, 94501 Komárno Tel.: +421-35-77-40-316 Fax: +421-35-7740-326 GSM: +421-905-930-972 e-mail: <a href="mailto:woodmizer@woodmizer.sk">woodmizer@woodmizer.sk</a></p>
<p><b>CZECH REPUBLIC Lubomir Kudlik Wood-Mizer Moravia</b> Sovadinova 6 69002 Breclav Tel./Fax: +420-519-322-443 <b>Lubomir Kudlik</b> GSM: +420-602-734-792 e-mail: <a href="mailto:info@wood-mizer.net">info@wood-mizer.net</a></p>	<p><b>LATVIA Vilmars Jansons OBERTS Ltd</b> Gaujas str. 32/2 LV-2167 Marupe, Rigas Raj. Tel.: +371-7-810-666 Fax: +371-7-810-655 <b>Vilmars Jansons</b> GSM: +371-92-06-966 <b>Andris Orols</b> GSM: +371-28-33-07-90 e-mail: <a href="mailto:andris@oberts.lv">andris@oberts.lv</a></p>	<p><b>TURKEY Er-Ka Ahsap Profil Kerestecilik San. ve Tic. Ltd. Sti.</b> Adana Keresteciler Sitesi 191 sk No.41 ADANA Tel.: +90-322-346-15-86 Fax: +90-322-345-17-07 GSM: +90-533-363-18-44 e-mail: <a href="mailto:info@erkaahsap.com.tr">info@erkaahsap.com.tr</a></p>
<p><b>FINLAND Howard Blackbourn Oy Falkberg Jordbruk Ab</b> Falkintie 220 25610 Ylonkyla Tel.: +358-2732-2253 Fax: +358-2732-2263 <b>Howard Blackbourn</b> GSM: +358-440-424-339 e-mail: <a href="mailto:falkberg@woodmizer.fi">falkberg@woodmizer.fi</a></p>	<p><b>LITHUANIA Andrius Zuzevicius UAB Singlis</b> Savanoriu pr. 187, 2053 Vilnius Tel.: +370-5-2-32-22-44 Fax: +370-5-2-64-84-15 GSM: +370-620-28-645 e-mail: <a href="mailto:andrius.z@singlis.lt">andrius.z@singlis.lt</a></p> <p><b>Dmitrij Gaiduk</b> GSM: +370-69-84-51-91 e-mail: <a href="mailto:dmitrijus.g@singlis.lt">dmitrijus.g@singlis.lt</a></p>	<p><b>UKRAINE Ivan Vinnicki MOST UKRAINA</b> bul. Myru 3, Bajkivtsi Ternoplskyj r-j Ternopolska oblast 47711 Ukraine Tel/Fax: +38 (0352) 52 37 74 GSM: +38 (067) 352 54 34 GSM: +38 (067) 674 50 68 E-mail: <a href="mailto:most-ukraina@ukr.net">most-ukraina@ukr.net</a></p>
<p><b>FRANCE Tizoc Chavez Wood-Mizer France</b> 556 chemin des Embouffus, ZAC des Basses Echarrieres 38440 SAINT JEAN DE BOURNAY Tel: +33-4 74 84 84 44 GSM: +33-607 52 02 82 Mail: <a href="mailto:tchavez@woodmizer.fr">tchavez@woodmizer.fr</a></p>	<p><b>NORWAY Odd Edvoll Wood-Mizer Nordic AS</b> Vardelia 17, 2020 Skedsmokorset Tel.: +47-63-87-49-89 Fax: +47-63-87-37-66 GSM: +47-930-42-335 e-mail: <a href="mailto:odd.edvoll@woodmizer.no">odd.edvoll@woodmizer.no</a></p> <p>e-mail: <a href="mailto:firmapost@woodmizer.no">firmapost@woodmizer.no</a></p>	<p><b>UNITED KINGDOM &amp; IRELAND Wood-Mizer UK</b> Hopfield Barn Kenward Road, Yalding Kent ME18 6JP, UK Tel.: +44-1622-813-201 Fax: +44-1622-815-534 e-mail: <a href="mailto:info@woodmizer.co.uk">info@woodmizer.co.uk</a></p>
<p><b>SLOVENIA Jan Fale FAMTEH d.o.o.</b> Gacnikova pot 2, 2390 Ravne na Koroskem Tel.: +386-2-62-04-232 Fax: +386-2-62-04-231 <b>Jan Fale</b> GSM: +386-2-62-04-230 e-mail: <a href="mailto:jan.fale@famteh.si">jan.fale@famteh.si</a></p> <p><b>Matjaz Kolar</b> Tel.: +386-2-62-04-232 GSM: +386-31-775-999 e-mail: <a href="mailto:matjaz.kolar@famteh.si">matjaz.kolar@famteh.si</a></p>		

<p><b>GERMANY Klaus Longmuss</b>  <b>Wood-Mizer Sägewerke GmbH</b>                  Dorfstraße 5, 29485 Schletau                  Tel.: +49-5883-9880-10                  Fax: +49-5883-9880-20                  e-mail: <a href="mailto:info@woodmizer.de">info@woodmizer.de</a></p> <p><b>Klaus Longmuss</b>                  Tel.: +49-5883-9880-12                  GSM: +49-17-298-55-892                  e-mail: <a href="mailto:KLongmuss@woodmizer.de">KLongmuss@woodmizer.de</a></p>	<p><b>Subagent:</b>  <b>SWEDEN Kjell Larsson</b>  <b>Mekwood AB</b>                  Slingan 14, 812 41 Gästrike-Hammarby                  Tel.: +46-290-515-65  <b>Kjell Larsson</b>                  GSM: +46-706-797-965                  e-mail: <a href="mailto:kjell.larsson@mekwood.se">kjell.larsson@mekwood.se</a></p>	<p><b>IRELAND</b>  <b>Wood-Mizer Ireland</b>                  Stephen Brennan                  Cum Lahardane Ballina County Mayo                  Tel:+353 96 51345</p> <p>E-mail: <a href="mailto:brennanmill@ericom.net">brennanmill@ericom.net</a></p>
<p><b>Subagents:</b>  <b>DENMARK Brian Jensen</b>                  Arnborgvej 9, 7330 Brande- Fasterholt                  Tel.: +45-971-88-265                  Fax: +45-971-88-266</p> <p><b>Brian Jensen</b>                  GSM: +45-23-49-5828                  e-mail: <a href="mailto:Fasterholt-Savvaerk@Mail.Tele.dk">Fasterholt-Savvaerk@Mail.Tele.dk</a></p>	<p><b>ROMANIA Adrian Echert</b>  <b>SC WOOD-MIZER RO SRL</b>                  TRANSILVANIEI Nr. 5                  Sibiu, Cisnadio 555300                  Tel./Fax: : +40-369-405-433                  GSM: +40-745-707-323                  e-mail: <a href="mailto:aechert@woodmizer.ro">aechert@woodmizer.ro</a></p>	<p>Regional Manager - Asia                  Wood-Mizer Asia Pte Ltd.                  James Wong                  Tel: +65 81216910                  Fax: +65 6283 8636                  WWW: <a href="http://www.woodmizerasia.com">www.woodmizerasia.com</a>                  E-mail: <a href="mailto:jwong@woodmizerasia.com">jwong@woodmizerasia.com</a></p>
<p><b>Netherlands Chris Dragt</b>                  Lange Brink 77d,                  7317 BD Apeldoorn                  Tel.: +31-55312-1833                  Fax: +31-55312-2042                  e-mail: <a href="mailto:Info@dragtbosbouw.nl">Info@dragtbosbouw.nl</a></p>	<p><b>Subagent:</b>  <b>ROMANIA M. Echert</b>  <b>S.C. Echert Comprod s.r.l</b>                  Str. Schitului Nr. 6, Apt.7 etajul-1                  725 70 Vatra Dornei, Romania                  Tel./Fax: +40-230-374-235                  Tel. : +40-740-35-35-74</p>	<p>Regional Manager - Africa                  Wood-Mizer Africa                  Jean-Jacques Oelofse                  UNIT 3, LEADER PARK, NO: 20 CHARIOT ROAD                  STORMILL, EXT 5, Roodepoort,                  Johannesburg                  Tel: +27 011 473 1313                  Fax: +27 011 473 2005                  Jean-Jacques Oelofse E-mail:  <a href="mailto:jjoelofse@woodmizerafrika.com">jjoelofse@woodmizerafrika.com</a>                  Jean-Jacques Oelofse                  Skype:jean.jacques.pierre.oelofse</p>

### USA World Headquarters

*Serving North & South America, Oceania, East Asia*

Wood-Mizer LLC  
 8180 West 10th Street  
 Indianapolis, IN 46214

Phone: 317.271.1542 or 800.553.0182  
 Customer Service: 800.525.8100  
 Fax: 317.273.1011  
 Email: [infocenter@woodmizer.com](mailto:infocenter@woodmizer.com)

### Canadian Headquarters

*Serving Canada*

Wood-Mizer Canada  
 396 County Road 36, Unit B  
 Lindsay, ON K9V 4R3

Phone: 705.878.5255 or 877.357.3373  
 Fax: 705.878.5355  
 Email: [ContactCanada@woodmizer.com](mailto:ContactCanada@woodmizer.com)

### Brazil Headquarters

*Serving Brazil*

Wood-Mizer do Brasil  
 Rua Dom Pedro 1, No: 205 Bairro: Sao Jose  
 Ivoti/RS CEP:93.900-000

Tel: +55 51 9894-6461/ +55 21 8030-3338/ +55 51  
 3563-4784  
 Email: [info@woodmizer.com.br](mailto:info@woodmizer.com.br)

### Europe Headquarters

*Serving Europe, Africa, West Asia*

Wood-Mizer Industries Sp z o.o.  
 Nagorna 114  
 62-600 Kolo, Poland

Phone: +48.63.26.26.000  
 Fax: +48.63.27.22.327

### Branches & Authorized Sales Centers

For a complete list of dealers, visit [www.woodmizer.com](http://www.woodmizer.com)

## SECTION 1 SERVICING THE EDGER

### 1.1 General Information

This documentation includes information on preparing the edger for operation and operating, servicing and repairing the machine.

The EG250E15-EMR/EG300E20S-EMR (EG250E20-EMR/EG300E25S-EMR) Edger is designed for sawing wood only (see the "Specifications" section in this manual for maximum wood dimensions). The machine must not be used for other purposes, such as cutting ice, metal or other materials.

Using the machine correctly you will achieve high degree of accuracy and rate of efficiency.

The edger should be operated only by an adult (a person who have attained the age of 18 years) who have read and understood the entire operator's manual. The edger is not intended for use by or around children.

The machine is built to be durable and easy to operate and maintain.

### 1.2 Customer and Edger Identification

Each Wood-Mizer edger has a serial number. In addition, when you pick up your edger, you will receive a customer number. These two numbers will help expedite our service to you. Please locate them now and write them below so you have quick and easy access to them.

**See Figure 1-1.** The figure below shows an exemplary identification plate of the EG300 Edger.

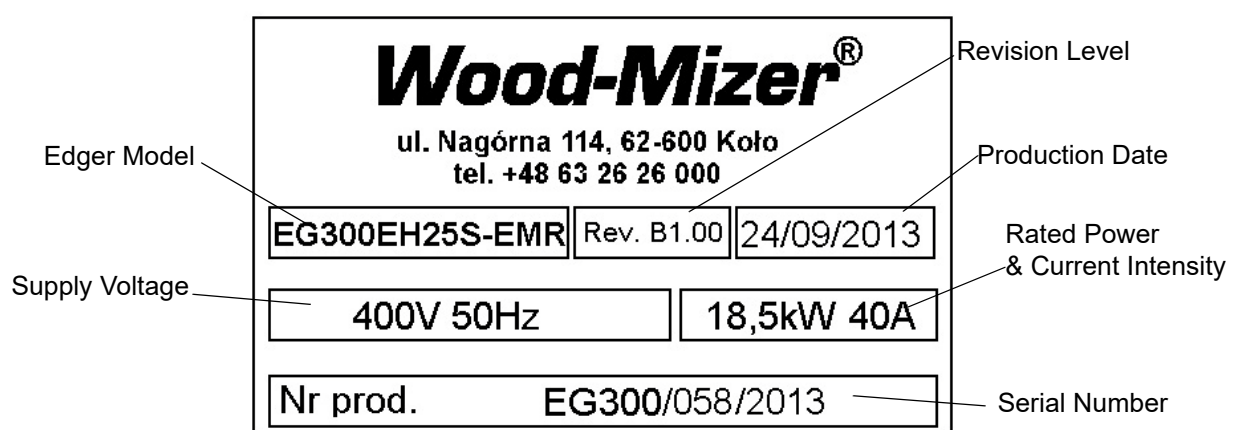
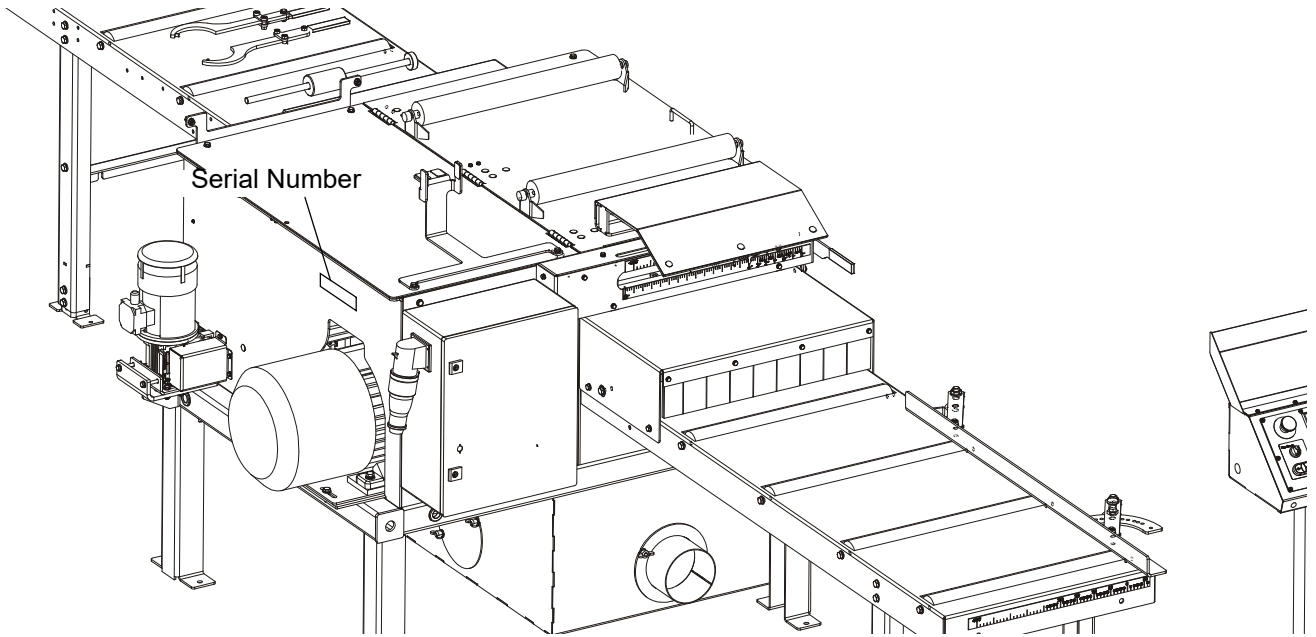

**FIG. 1-1**

# 1 Servicing The Edger

*Customer and Edger Identification*

See Figure 1-2. See the following figures for serial number locations.



**FIG. 1-2**

### 1.3 Edger Components

See Figure 1-3. The major components of the EG300 Edger are shown below.

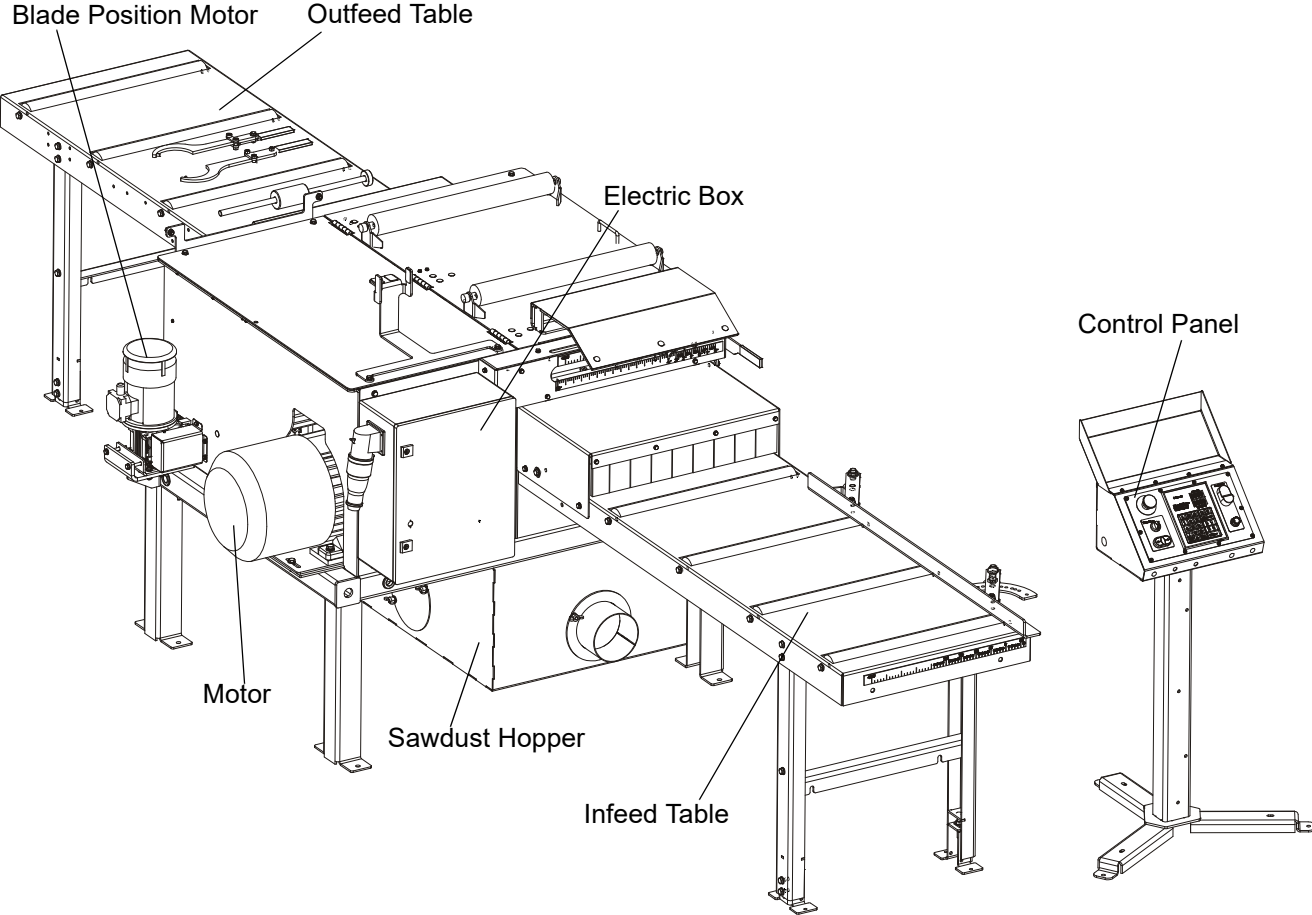

FIG. 1-3 EG300

# 1 Servicing The Edger

## Edger Components

See Figure 1-4. The major components of the EG250 Edger are shown below.

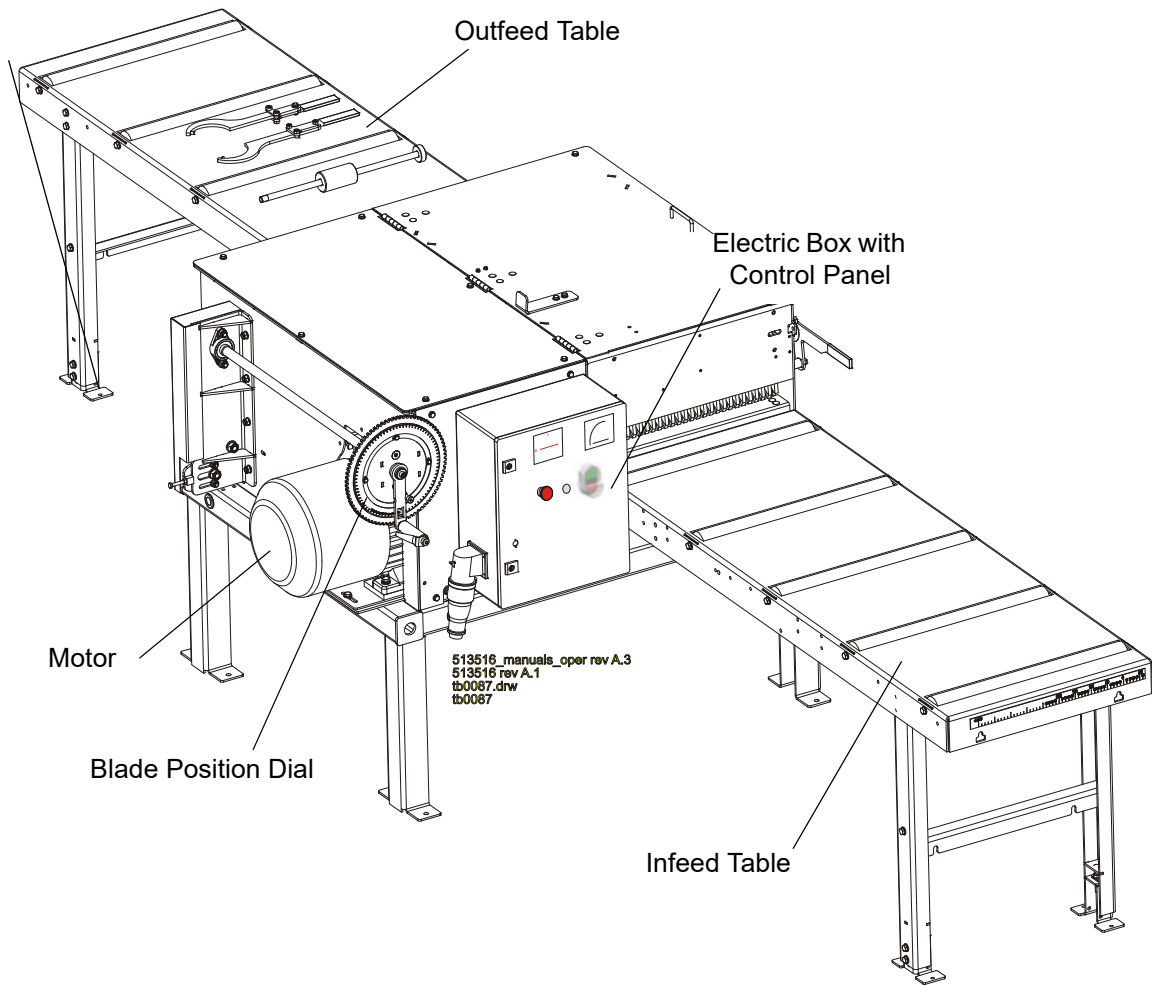

FIG. 1-4 EG250

## SECTION 2 SAFETY

### 2.1 Safety Symbols

The following symbols and signal words call your attention to instructions concerning your personal safety. Be sure to observe and follow these instructions.



**DANGER!** indicates an imminently hazardous situation which, if not avoided, will result in death or serious injury.



**WARNING!** suggests a potentially hazardous situation which, if not avoided, could result in death or serious injury.



**CAUTION!** refers to potentially hazardous situations which, if not avoided, may result in minor or moderate injury or damage to equipment.



**IMPORTANT!** indicates vital information.

**NOTE:** gives helpful information.



Warning stripes are placed on areas where a single decal would be insufficient. To avoid serious injury, keep out of the path of any equipment marked with warning stripes.

### 2.2 Safety Instructions

**NOTE:** ONLY safety instructions regarding personal injury are listed in this section. Caution statements regarding only equipment damage appear where applicable throughout the manual.

#### *Observe Safety Instructions*



**IMPORTANT!** Read the entire Operator's Manual before operating the Edger. Take notice of all safety warnings throughout this manual and those posted on the machine. Keep this manual with this machine at all times, regardless of ownership.

Also read any additional manufacturer's manuals and observe any applicable safety instructions including dangers, warnings, and cautions.

Only persons who have read and understood the entire operator's manual should operate the Egder. The Egder is not intended for use by or around children.

**IMPORTANT!** It is always the owner's responsibility to comply with all applicable federal, state and local laws, rules and regulations regarding the ownership and operation of your Wood-Mizer Egder. All Wood-Mizer owners are encouraged to become thoroughly familiar with these applicable laws and comply with them fully while using the Egder.



### Wear Safety Clothing



**WARNING!** Secure all loose clothing and jewelry before operating the machine. Failure to do so may result in serious injury or death.

**WARNING!** Always wear gloves and eye protection when handling bandsaw blades. Changing blades is safest when done by one person! Keep all other persons away from area when coiling, carrying or changing a blade. Failure to do so may result in serious injury.

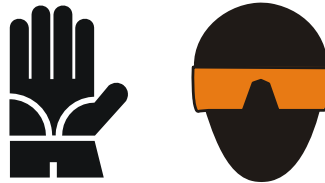

**WARNING!** Always wear ear, respiration and foot protection when operating or servicing the Egder.





### Keep Egder And Area Around Clean



**DANGER!** Maintain a clean and clear path for all necessary movement around the Egder and lumber stacking areas. Failure to do so will result in serious injury.

### Dispose Of Sawing By-Products Properly



**IMPORTANT!** Always properly dispose of all sawing by-products, including sawdust and other debris.

### Check Egder Before Operation



**DANGER!** Make sure all guards and covers are in place and secured before operating the Egder. Failure to do so may result in serious injury.



**WARNING!** Always shut off the motor to stop the blade whenever the Egder is not in use. Failure to do so may result in serious injury.

**WARNING!** Do not for any reason adjust the motor drive belts with the motor running. Doing so may result in serious injury.

**WARNING!** Always ensure that there is a sharp point on the anti-kickback fingers before each use of the Egder.

Be sure the anti-kickback fingers are free from obstruction and are in a downward position with the lever released. Failure to do so may result in serious injury.

### Keep Persons Away



**DANGER!** Keep all persons out of the path of moving equipment and boards when operating the Egder. Failure to do so will result in serious injury.

**Keep Hands Away**

**DANGER!** Motor components can become very hot during operation. Avoid contact with any part of a hot motor. Contact with hot motor components can cause serious burns. Therefore, never touch or perform service functions on a hot motor. Allow the motor to cool sufficiently before beginning any service function.

**DANGER!** Moving Parts Can Crush and Cut. Keep hands clear. Make sure all guards and covers are in place and secured before operating or towing. Failure to do so may result in serious injury.

**DANGER!** Always be aware of and take proper protective measures against rotating shafts, pulleys, fans, etc. Always stay a safe distance from rotating members and make sure that loose clothing or long hair does not engage rotating members resulting in possible injury.

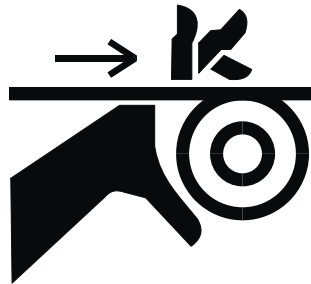

**WARNING!** Coastdown Required. Always shut off the motor and allow all moving parts to come to a complete stop before removing any guards or covers. Do NOT operate with any guards or covers removed.

**WARNING!** Kickback Hazard. Stay clear of area during operation. Follow all anti-kickback service and safety rules. Failure to do so may result in serious injury.



**DANGER!** Before changing the blades or performing any service to the machine, disconnect the power cord from the electric box.

**IMPORTANT!** The blade housing and drive assembly covers are equipped with safety key switches. As soon as you open the cover, the motor will get turned off and all moving parts will stop spinning. The safety switches should always be in proper working condition.

**IMPORTANT!** The cutting width system is equipped with a safety switch. When you feed a board into edger, the cutting width setting is blocked.

### Use Proper Maintenance Procedures



**DANGER!** Make sure all electrical installation, service and/or maintenance work is performed by a qualified electrician and is in accordance with applicable electrical codes.

**DANGER!** Hazardous voltage inside the electric boxes and at the motor can cause shock, burns, or death. Disconnect and lock out power supply before servicing! Keep all electrical component covers closed and securely fastened during machine operation.



**WARNING!** Consider all electrical circuits energized and dangerous.

**WARNING!** Disconnect and lock out power supply before servicing! Failure to do so may result in serious injury.

**WARNING!** Never assume or take the word of another person that the power is off; check it out and lock it out.

**WARNING!** Do not wear rings, watches, or other jewelry while working around an open electrical circuit.

**DANGER!** The operator must not for any reason perform any laser-maintenance or repair work.



**IMPORTANT!** Edger is equipped with two emergency stop buttons - one at the front, the other at the rear of the machine. They are used to immediately stop the motor and/or Edger operation in hazardous situations. The emergency stop buttons should always be in proper condition.

**Keep Safety Labels In Good Condition**



**IMPORTANT!** Always be sure that all safety decals are clean and readable. Replace all damaged safety decals to prevent personal injury or damage to the equipment. Contact your local distributor, or call your Customer Service Representative to order more decals.

**IMPORTANT!** If replacing a component which has a safety decal affixed to it, make sure the new component also has the safety decal affixed.

**Fire-Fighting**

**CAUTION!** The edger's work-stand should be equipped with a 4 kg or bigger dry powder extinguisher.

**Safety Labels Description**

See Table 2-1. See table below for safety labels description.

**TABELA 2-1**

Decals View	Decal No.	Description
	099220	Close guards prior to operating the machine
	096316	Electric box opening is possible with the switch in "0" position only.

**TABELA 2-1**







	<p>096319</p>	<p>Always disconnect the power cord before opening the electric box.</p>
	<p>099540</p>	<p>CAUTION! Gear train - Keep safe distance!</p>
	<p>S12004G</p>	<p>Always wear eye protection equipment when operating this machine.</p>
	<p>S12005G</p>	<p>Always wear ear protection equipment when operating this machine.</p>

TABELA 2-1

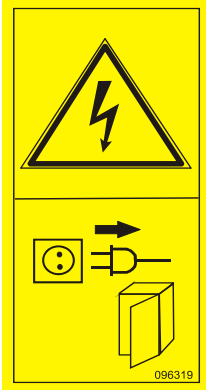
	501465	Always wear safety boots when operating this machine.
	501467	Lubrication point
	099504	Visible and/or invisible laser radiation. Avoid eye or skin exposure to direct or scattered radiation.
	P85070	CE certified machine
	089296	Rotation direction
	S20097	Motor rotation direction

## SECTION 3 OPERATION

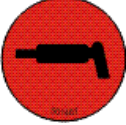
### 3.1 Pre-Operation Check

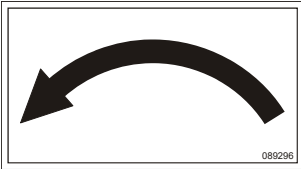
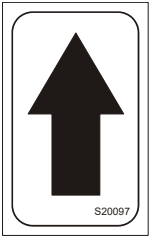
Prior to operating the Edger; always perform these basic checks:

1. Make sure the Edger is level. Secure the legs to the surface. Cement pads or foundations must be built. Legs must be fastened to the foundation using 16mm anchored bolts.



**CAUTION!** Always be sure the machine is level prior to operating. Failure to do so can and will affect machine operation and wear life.

2. Make sure the tables are level with the rest of the Edger. Legs must be fastened to the foundation using 16mm anchored bolts.

3. Make sure the motor drive belt is tensioned properly.



**WARNING!** Do not for any reason adjust the motor drive belts with the motor running. Doing so may result in serious injury.

4. Be sure the anti-kickback fingers are in proper working condition.



**WARNING!** Always ensure that there is a sharp point on the anti-kickback fingers before each use of the Edger.

Be sure anti-kickback fingers are free from obstruction and are in a downward position with lever released. Failure to do so may result in serious injury.

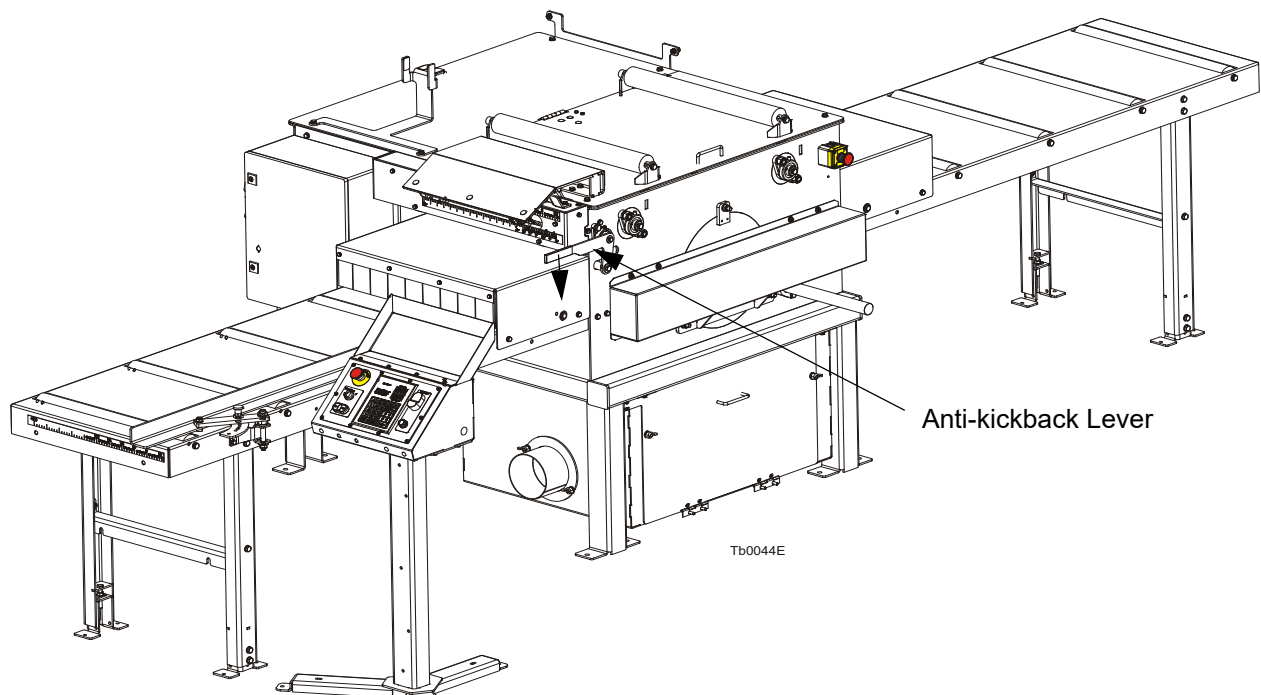

FIG. 3-1

5. Be sure all guards and covers are in place and secured.



**DANGER!** Make sure all guards and covers are in place and secured before operating or towing the Edger. Failure to do so may result in serious injury.

6. Also be aware that the blades are spinning whenever the motor is ON. You should always turn off the motor to stop the blade whenever the Edger is not in use and ensure that all parts have stopped moving before removing any covers or guards.



**WARNING!** Coastdown Required. Always shut off the motor and allow all moving parts to come to a complete stop before removing any guards or covers. Do NOT operate with any guards or covers removed.

**WARNING!** Always shut off the motor to stop the blade whenever the Edger is not in use. Failure to do so may result in serious injury.



**IMPORTANT!** If at any time you need to immediately stop the motor and/or Edger operation, press the Emergency Stop button located at



the front or at the rear of the Edger.

Emergency Stop  
Twist to release

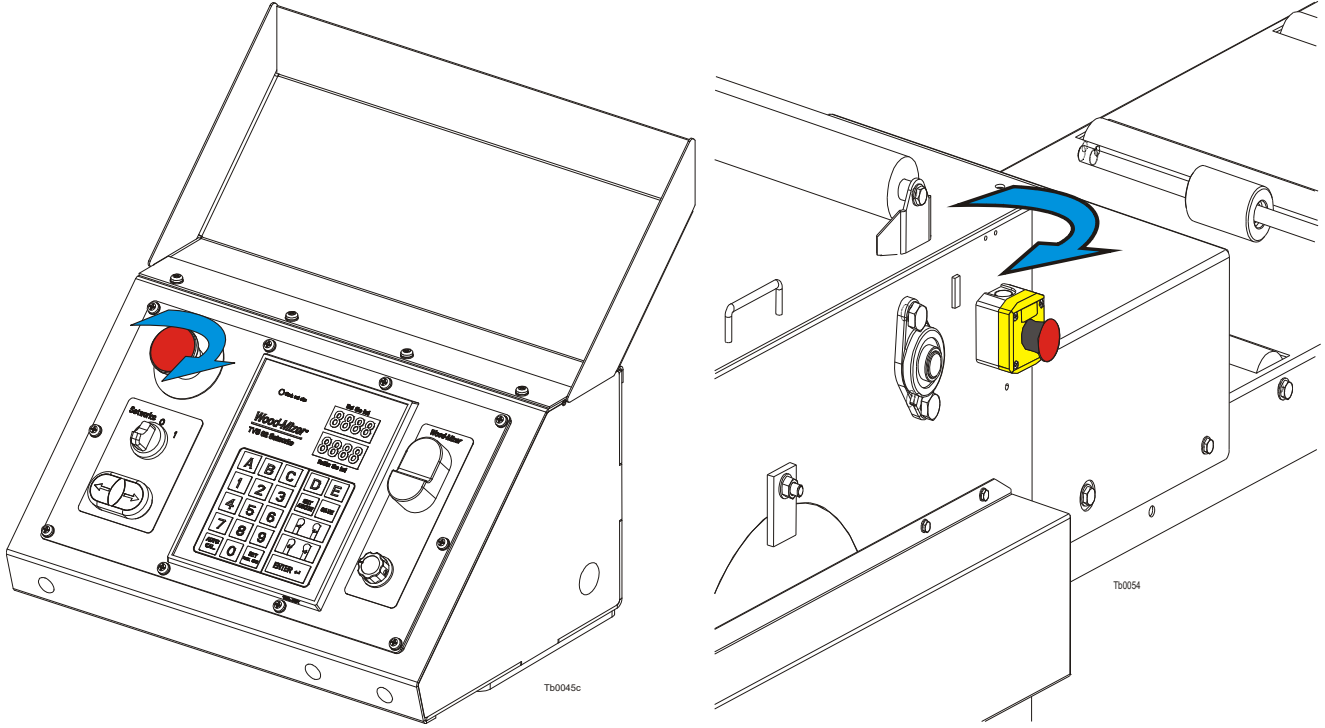

**FIG. 3-2 EG300 E-STOP LOCATION (CE ONLY)**

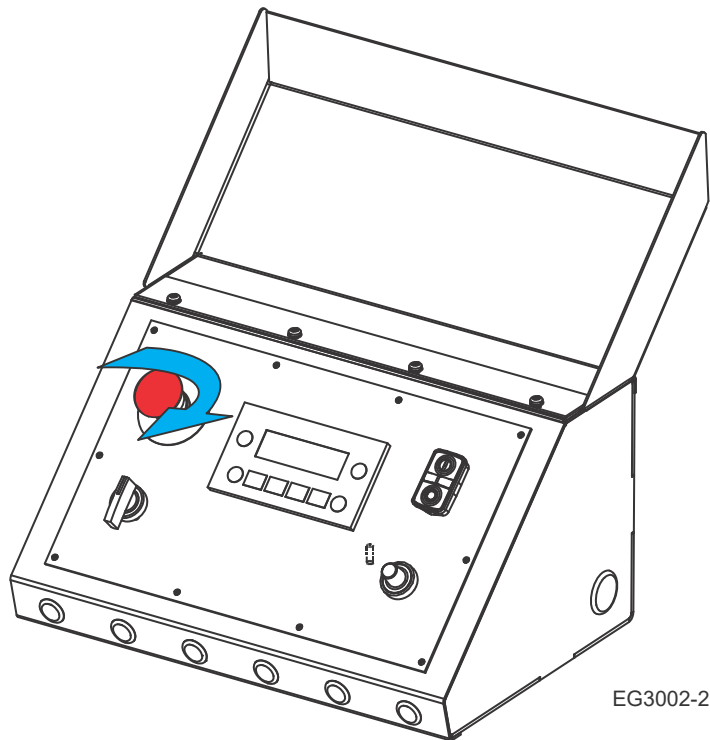

**FIG. 3-3 EG300 E-STOP LOCATION (U.S. ONLY)**

# 3

## OPERATION

### Pre-Operation Check

Emergency Stop  
Twist to release

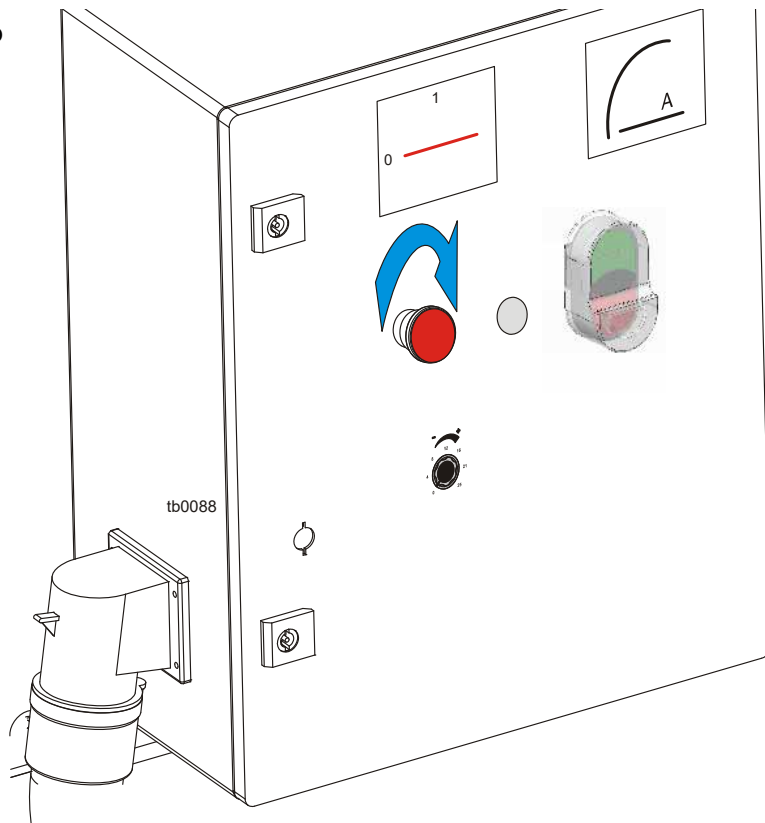

**FIG. 3-4 EG250 E-STOP LOCATION (CE ONLY)**

## 3.2 Control Overview

### Control Panel, EG300

See **Figure 3-5**. The control panel includes: START-STOP switch, blade distance automatic controller, feed rate knob, automatic controller ON/OFF (CE Only) switch, additional switches for

# 3

## OPERATION

### Control Panel, EG300

setting blades distance and emergency stop button.

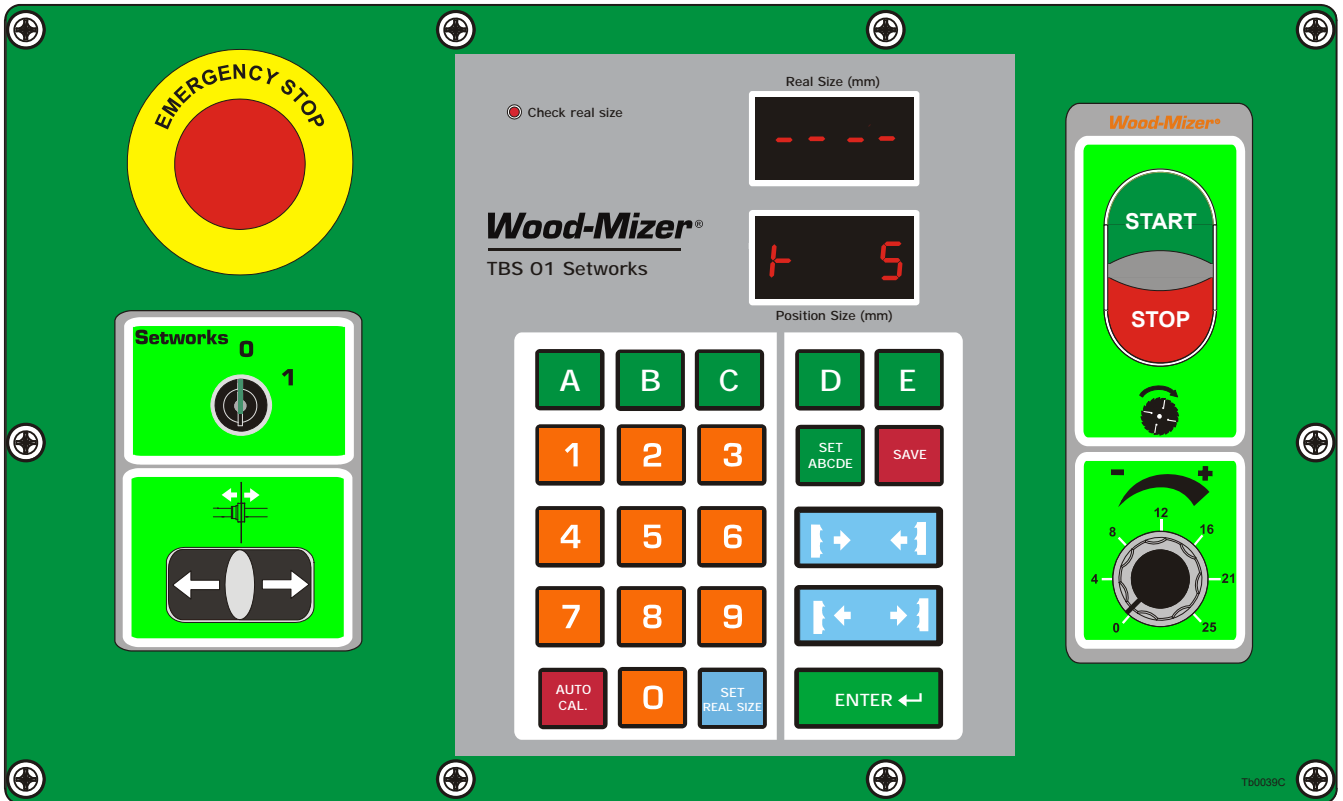

FIG. 3-5 EG300 CONTROL PANEL COMPONENTS (CE ONLY)

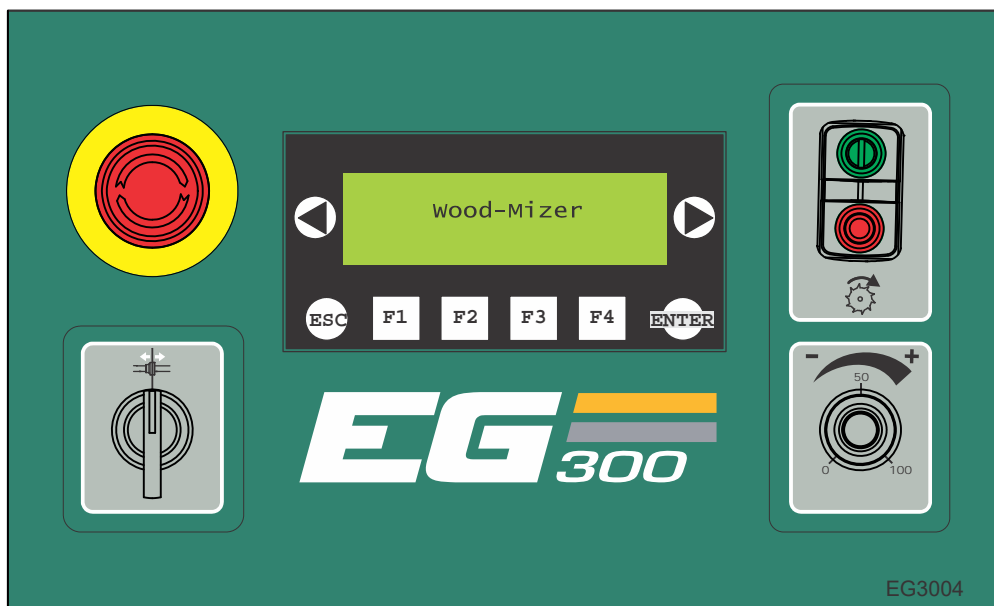

FIG. 3-5 EG300 CONTROL PANEL COMPONENTS (U.S ONLY)

Fig. 3-5

**1. Blade Drive**



To start the blade motor press the START button. To stop the blade motor, press the STOP button.

**2. Feed Roller Speed Adjustment**



The feed roller speed switch controls the speed at which the feed roller moves. Turn the switch right to increase the speed, turn left to reduce the speed.

**3. Edger (CE Only) Networks Controller**

Allows to set blade position automatically. *See SECTION 4 NETWORKS OPERATION (Optional Equipment) (U.S. Only)*

**4. Emergency Stop**

Push the emergency stop button to stop the blade and the track feed motors. Turn the emergency stop clockwise to release the stop. The machine will not restart until the emergency stop is released.

**Control Panel, EG250**

See Figure 3-6. The control panel components are listed below.

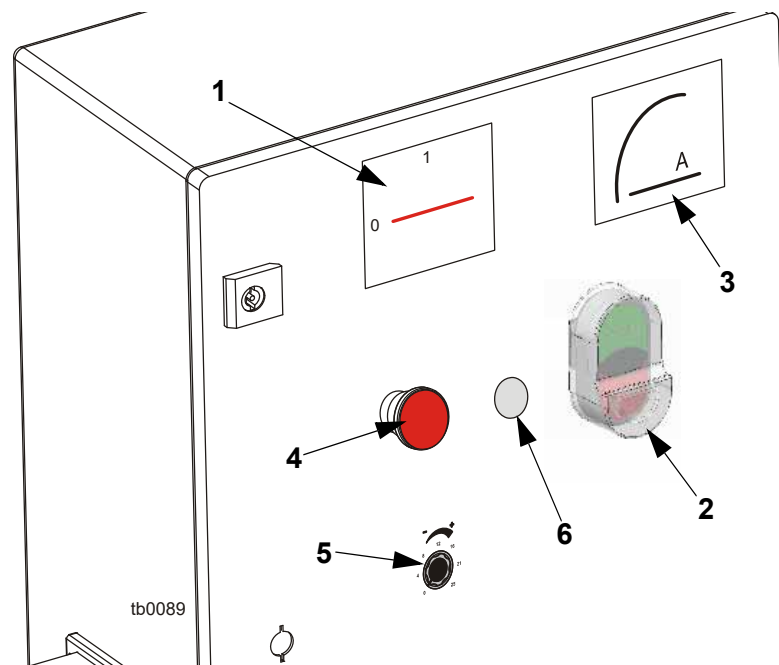

**FIG. 3-6 EG250 CONTROL PANEL COMPONENTS**

**1. Main Disconnect Switch**

Disconnects power from all electrical circuits of the machine.

## 2. Motors START/STOP Button

To start the blades and feed motors press the START button. To stop the motors, press the STOP button.

## 3. Ammeter

Indicates current power consumption of all machine motors.

## 4. Emergency Stop

Push the emergency stop button to stop all motors. Turn the emergency stop clockwise to release the stop. The machine will not restart until the emergency stop is released.

## 5. Feed Roller Speed Adjustment



The feed roller speed switch controls the speed at which the feed roller moves. Turn the switch right to increase the speed, turn left to reduce the speed. (Optional Equipment).

## 6. Power ON Control Light

Indicates the power supply.

### 3.3 Edger Setup



**IMPORTANT!** Before starting to use the Edger you have to meet the following conditions:

- Set up the machine on firm and level ground.
- The machine must be operated with the sawdust exhaust system.
- The edger must not be operated outdoors when it is raining/snowing and in case of rain/snow the edger must be stored under a roof or indoors.
- The machine can be operated in temperature range from  $-15^{\circ}\text{C}$  to  $40^{\circ}\text{C}$  ( $5^{\circ}\text{F}$  to  $104^{\circ}\text{F}$ ) only.
- Light intensity at operators position must be  $300\text{lx}$ .<sup>1</sup>

---

<sup>1</sup> Light source can not cause the stroboscopic effect.

■ The machine operator's (two persons) position is shown below.

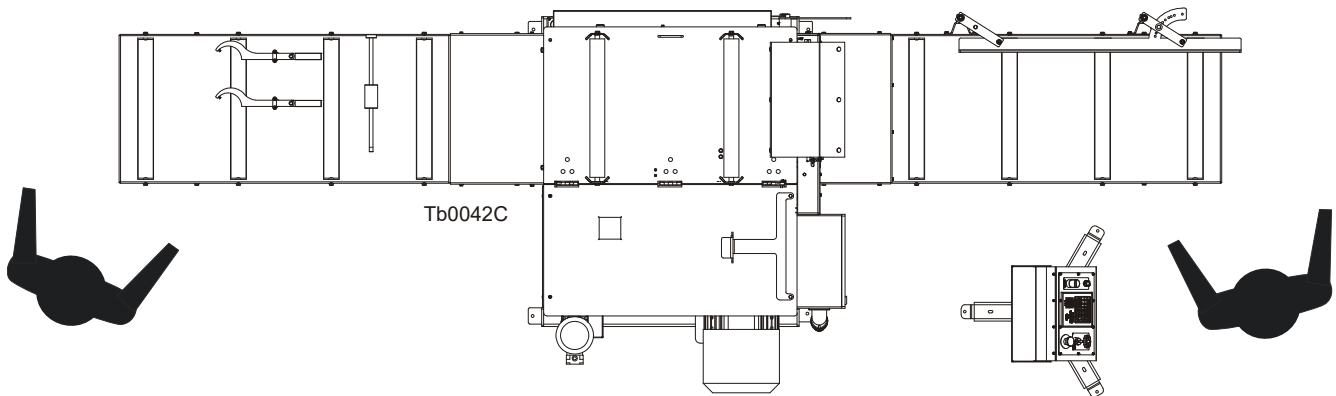

**FIG. 3-7 EG300**

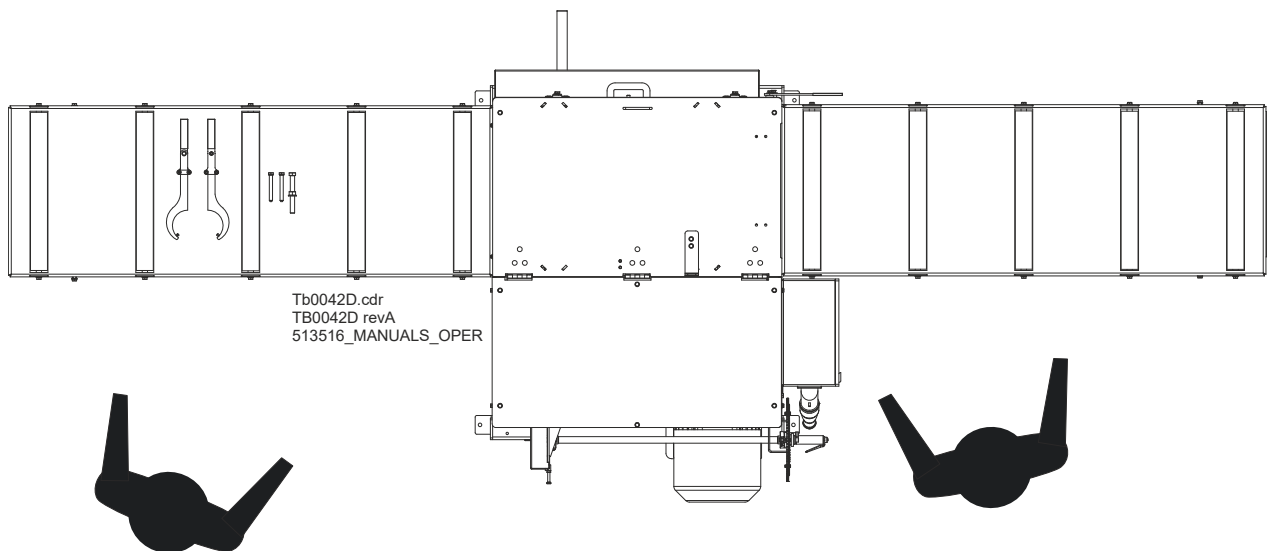

**FIG. 3-8 EG250**

■ Have a qualified electrician install the power supply (according to EN 60204 Standard).  
 The power supply must meet the specifications given in the table below.

3-Phase Volts	Fuse Disconnect	Suggested Wire Size
400 VAC	40 Amps	11 AWG / 4 mm <sup>2</sup> , up to 15 m/ 49 ft long

**TABLE 3-1**



**IMPORTANT!** It is recommended that the electrical system be equipped with a 30mA Ground Fault Interrupter.

**IMPORTANT!** When starting the machine for the first time, check that blade rotation direction is as indicated by the arrow located on the blades covers. If the rotation direction is incorrect, invert the phases in the phase inverter located in the power socket (electric box). Setting the phases in the phase inverter correctly will ensure correct rotation directions of all machine motors.

**IMPORTANT!** When starting the machine for the first time, let it run without any load for 1-2 hours. It will let the infeed and outfeed tables drive components to grind in.

- The Edger can be lifted using the forklift only. Forklift must be rated for at least 2000kg (4409 lb). Edger is equipped with forklift pockets. Remove sawdust hopper before lifting the Edger by forklift. Insert the forks into the pockets shown on the picture below.

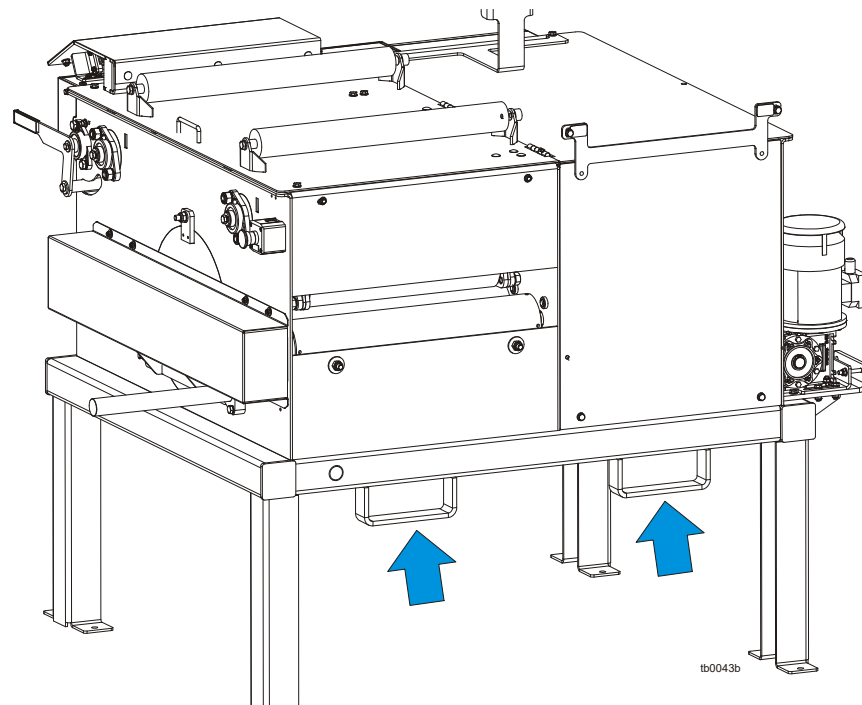
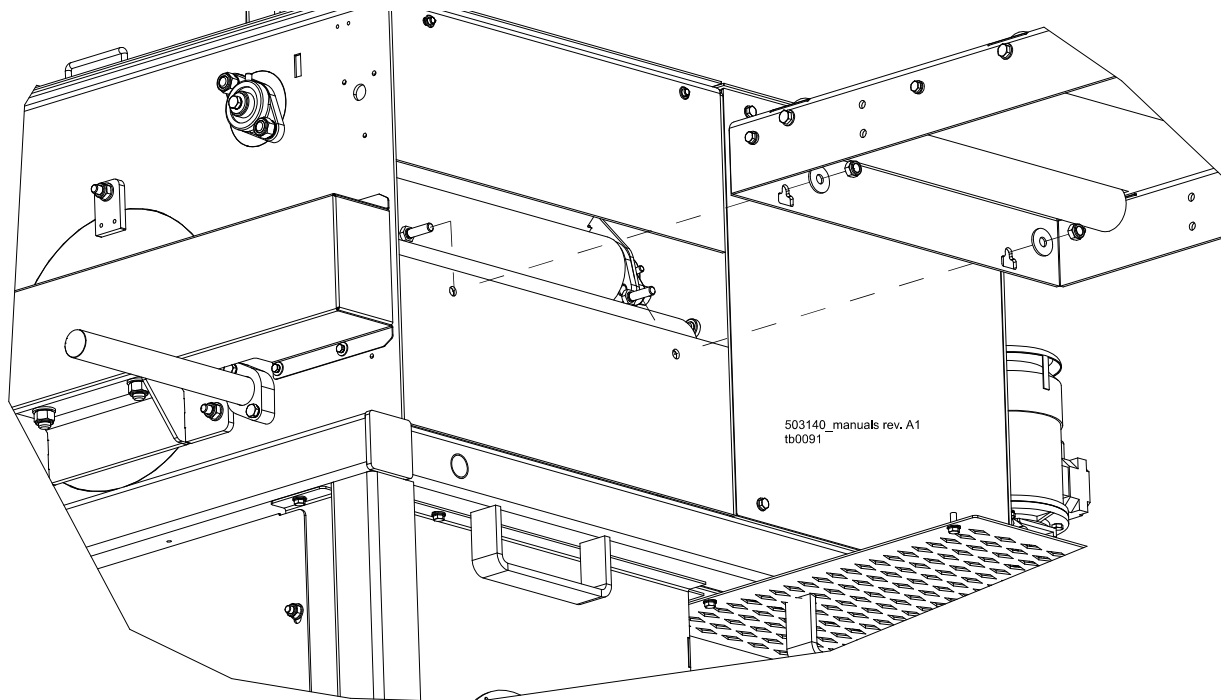

FIG. 3-9



- Mount the outfeed table using M12x40 bolts, 13 washers and M12 nuts.



**FIG. 3-10**

- Mount the outfeed table using the M12x40 bolts, 13 washers, M12 nuts and the supplied special spacers (1 and 1.5mm thick). Place a bar along the inside edge of the blade as shown in the figure # 3-12. Add or remove the spacers to align the table so that the distances A and B

### 3 OPERATION

#### Edger Setup

are equal.

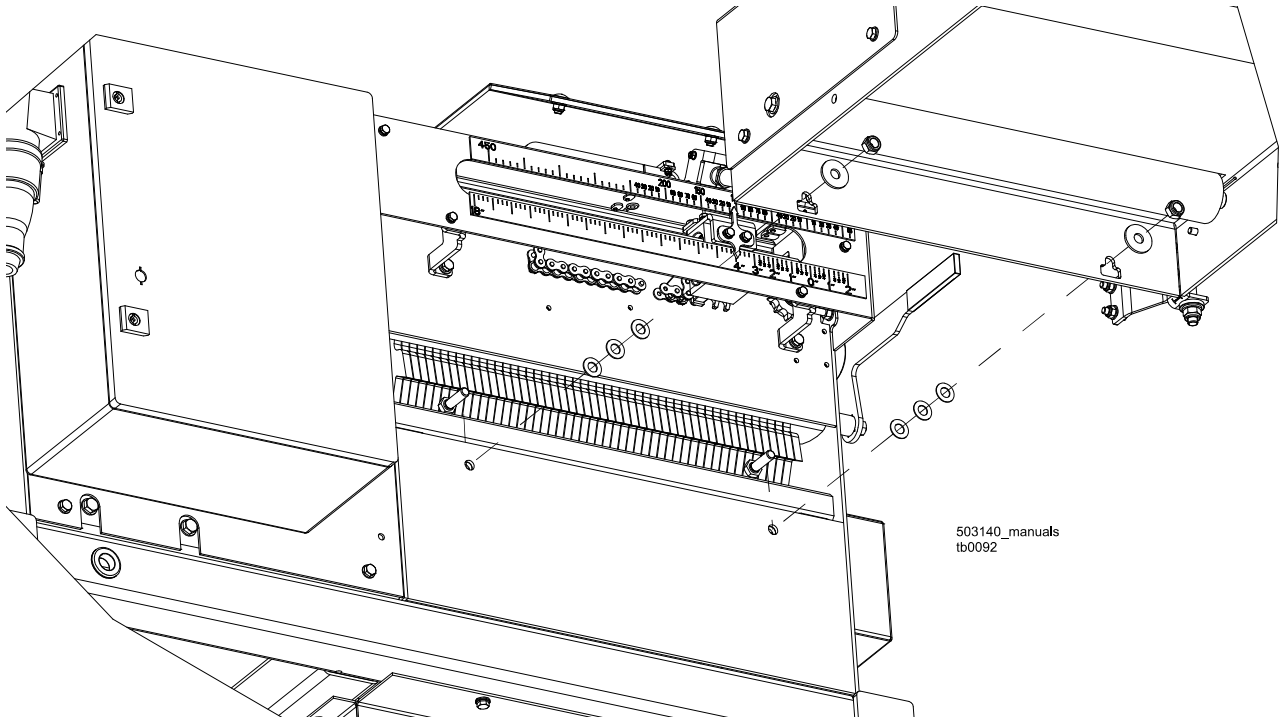

FIG. 3-11

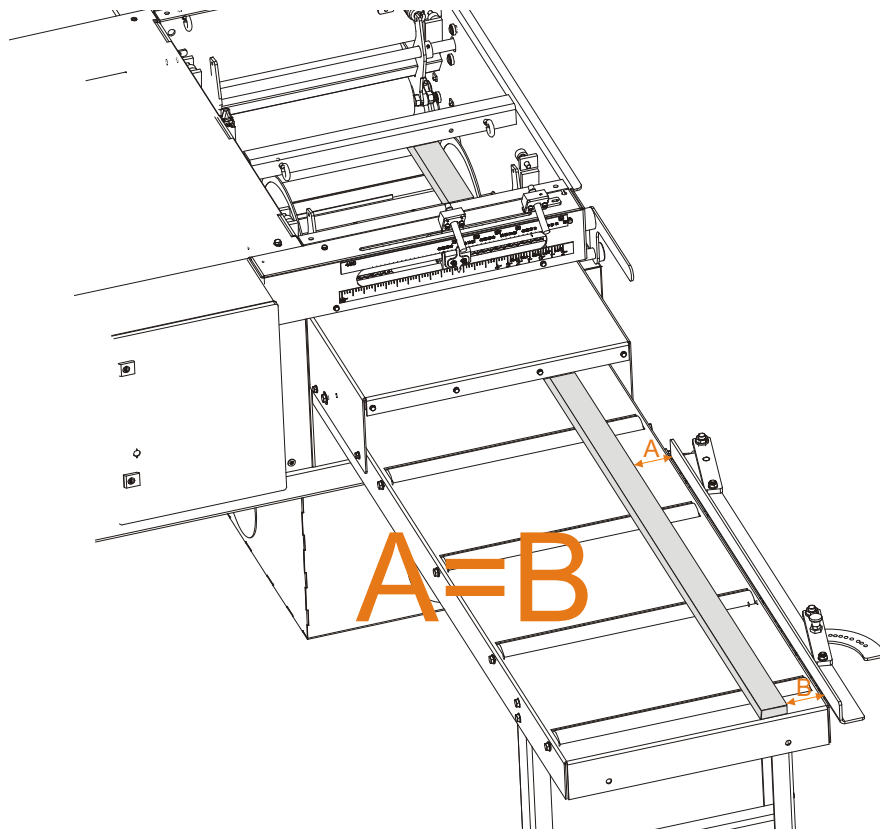

FIG. 3-12

### 3.4 Machine Start



**DANGER!** Before starting the machine, perform these steps to avoid injury and/or damage to the equipment:

- Close the blade housing covers and replace any guards removed for service.
- Check the feed rollers and remove all loose objects such as tools, wood, etc.
- Make sure all persons are a safe distance from the machine.
- Check that the emergency stops are released.

**NOTE:** The machine will not start if either of the emergency stops is on.

Before starting the blades, check that the main power switch on the electric box is on.

**See Figure 3-13.** Start the blade motors. To do this, push the START button on the control panel (see the figure below). The motor should start and the feed rollers should start. To stop the blade motor, push the Stop button shown in the figure above. The motor also may be stopped by pushing the emergency stop button.

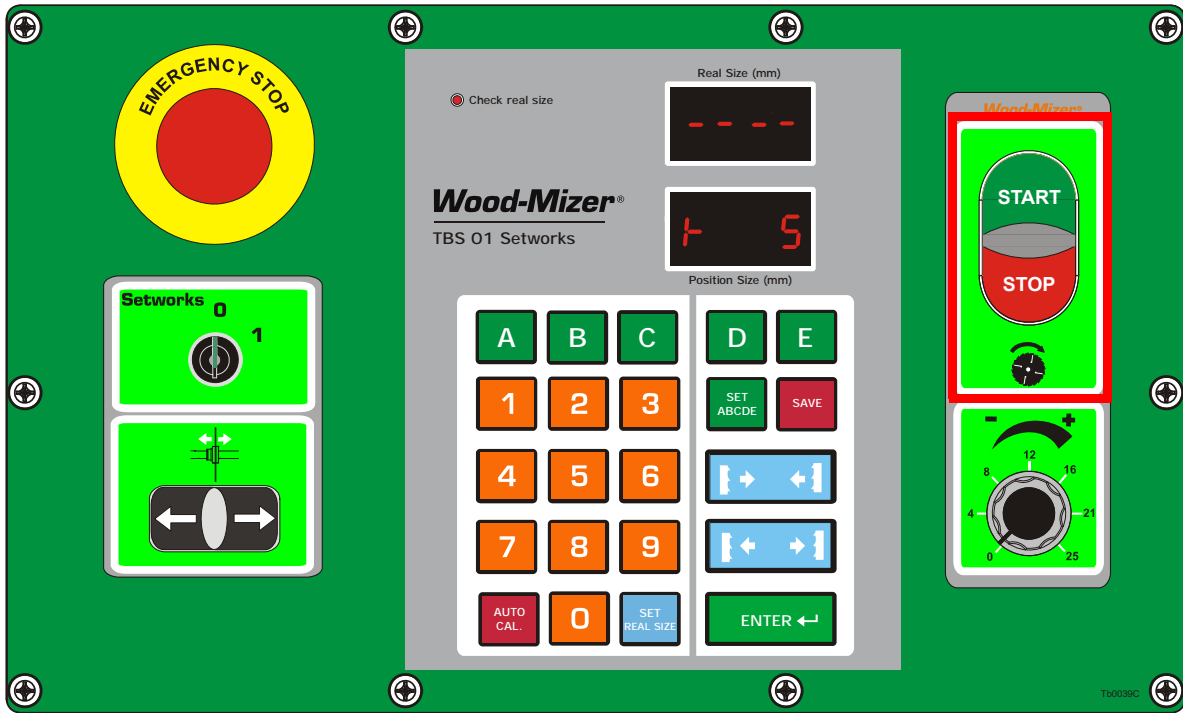

FIG. 3-13 EG300 CONTROL PANEL (CE ONLY)

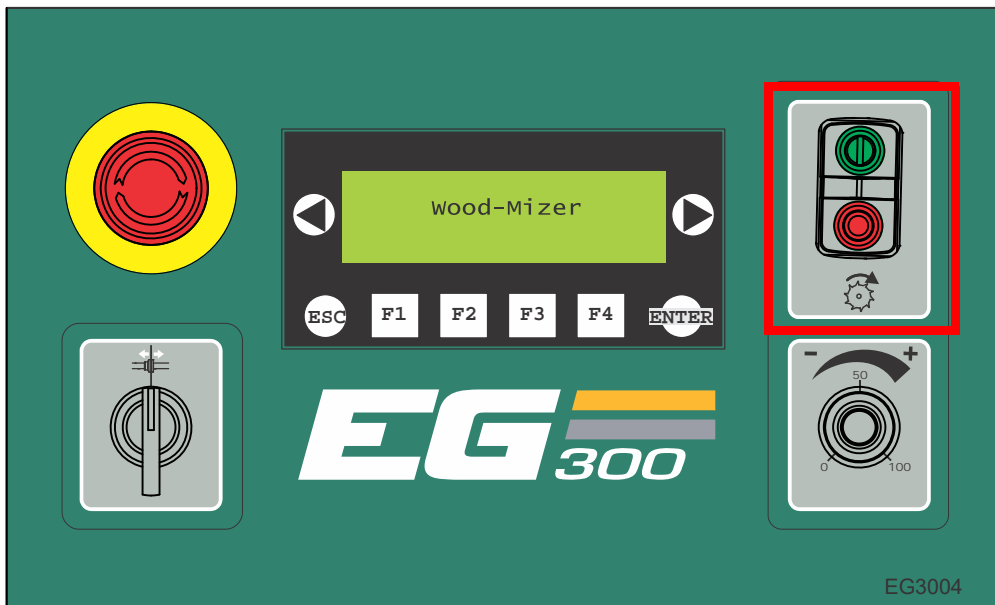
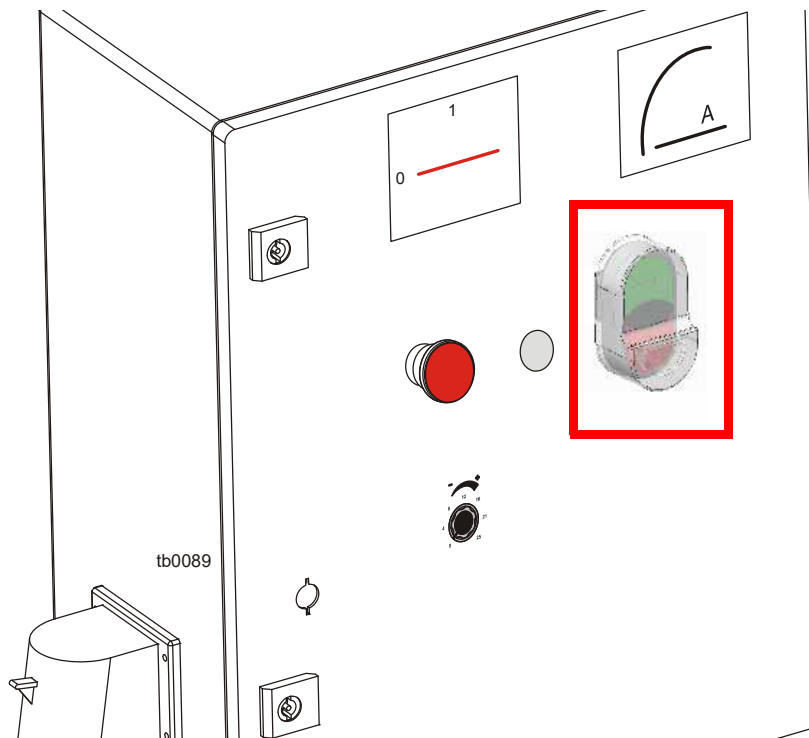

FIG. 3-13 EG300 CONTROL PANEL (U.S. ONLY)



**FIG. 3-13 EG250 CONTROL PANEL**

# 3

## OPERATION

### Machine Start

See Figure 3-14. The speed at which the feed rollers move is adjustable by dial located on the control panel, allows the operator to adjust the feed rate from 0 to ca. 25 m / 82 ft per minute.

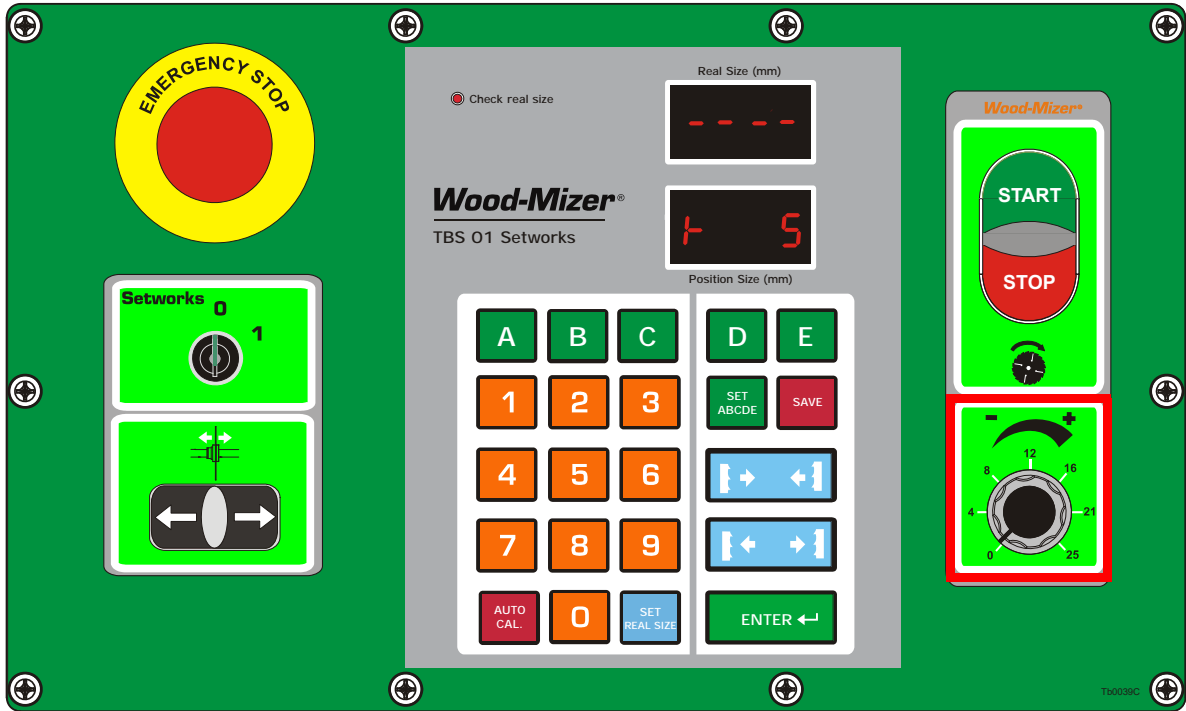

FIG. 3-14 EG300 (CE ONLY)

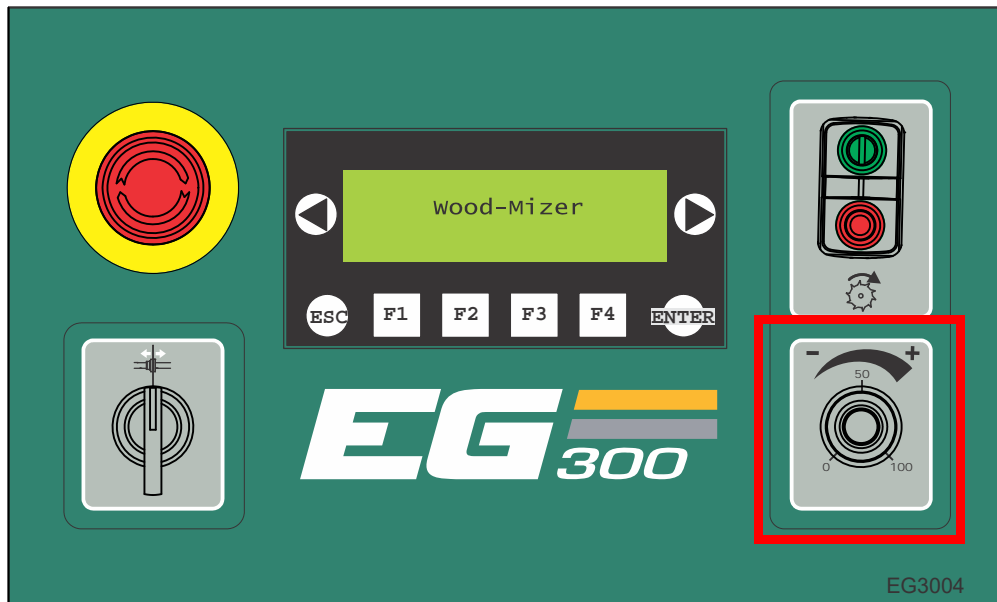
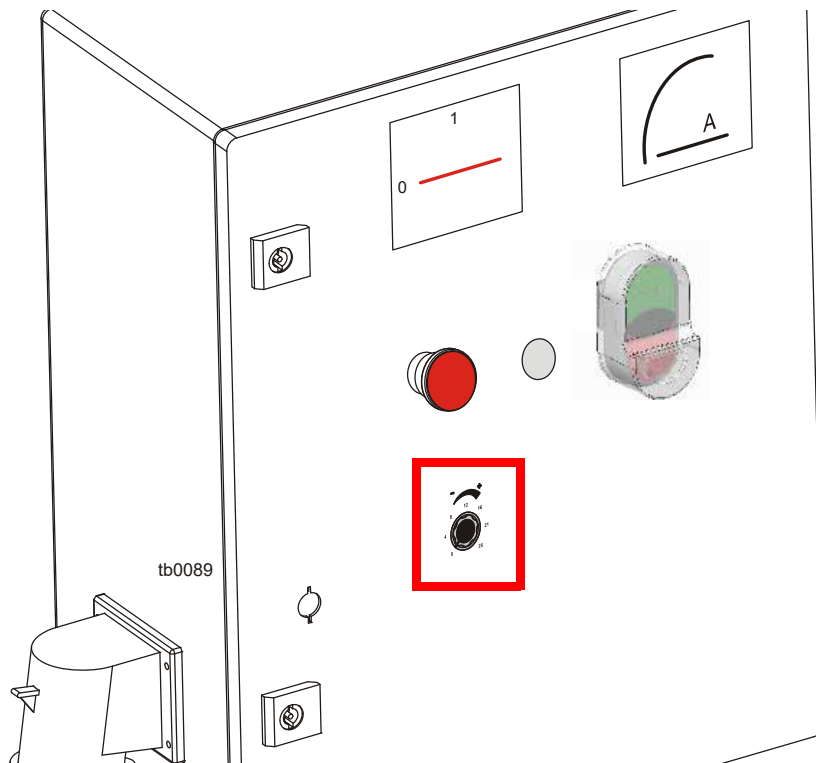

FIG. 3-14 EG300 (U.S. ONLY)



**FIG. 3-14 EG250**

Turn the switch clockwise to increase the feed rate, counterclockwise to slow the feed rate down.

**Factors that will determine what feed rate you can use include:**

- Material thickness.
- Hardness of material to be cut. Some woods that are seasoned or naturally very hard will require slower feed rates.
- Sharpness of blades. Dull or improperly sharpened blades will require slower feed rates than sharp and properly maintained blades.
- Off-bearing capability. Your ability to feed will also determine what feed rate you can use.

## 3.5 Blade Installation

### *Multirip Option*

The main shaft's strength and motor horsepower allows you to use maximally five blades with your Edger. Never use more than five blades! The standard Wood-Mizer Edger is equipped with two blades. The additional three blades in Edger are installed on the provided bushing with spacers.

The blades should be installed on the main shaft in the following order:

- movable blade arbor,
- fixed blade arbor,
- bushing with three blades.

**NOTE:** It is necessary to adjust the movable blade limit switch after installing the bushing with additional blades. To do that, measure the distance from the left edge of the fixed blade arbor to the left edge of the bushing with additional blades (see the figure below). Then loosen the screws and move the limit switch left, the measured distance.



**WARNING!** Failure to adjust the safety switch after installing additional blades may result in machine damage.



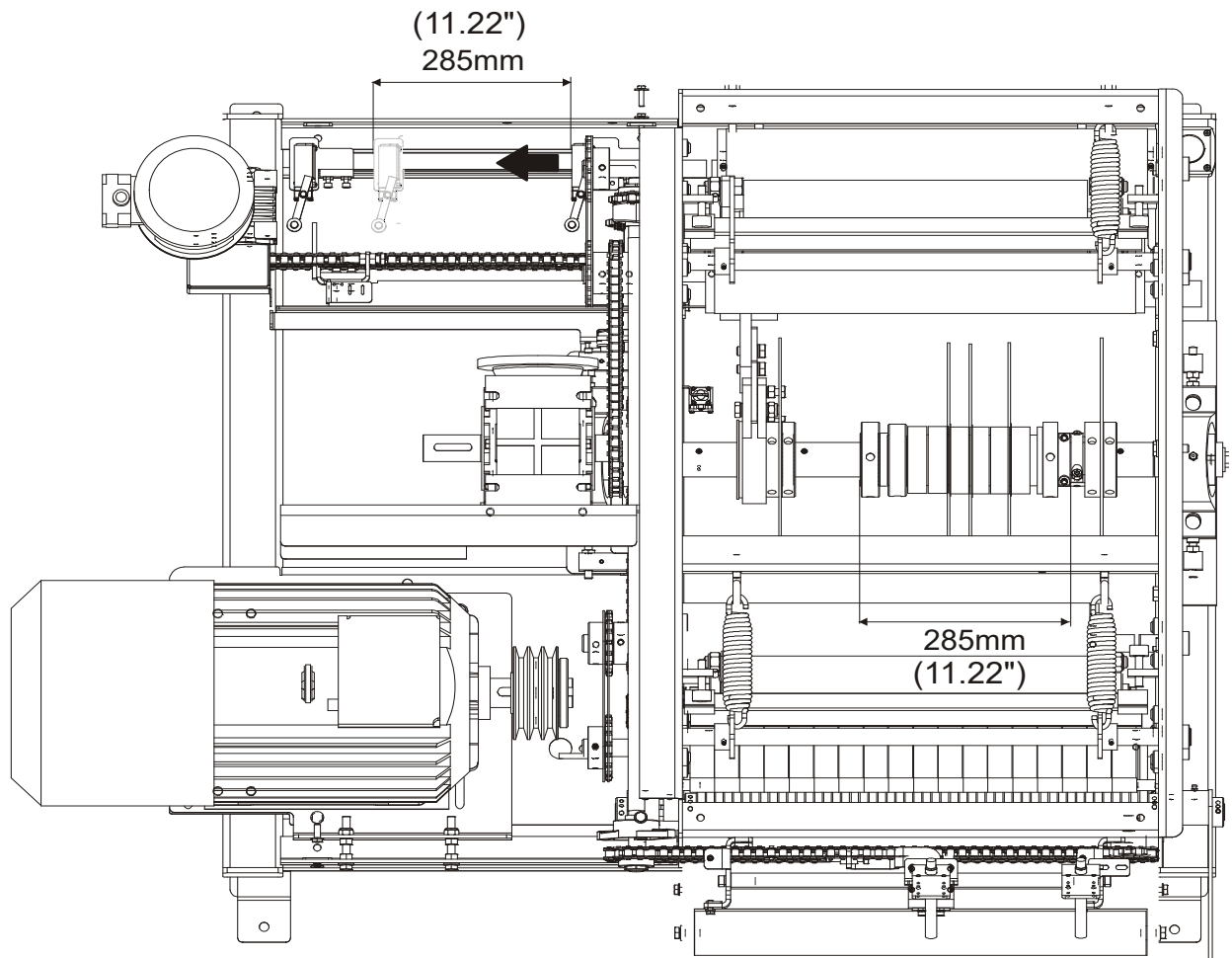

FIG. 3-15

**NOTE(EG300 only) (CE Only):** After installing the additional bushing with blades, you should turn off the Setworks controller because the remaining range of movable blade movement is insufficient for performing the auto-calibration. However, you can still automatically move the movable blade in the remaining range of its movement - using the additional blades distance setting switches located below the Setworks controller ON/OFF switch.

### 3 OPERATION

Multirip Option

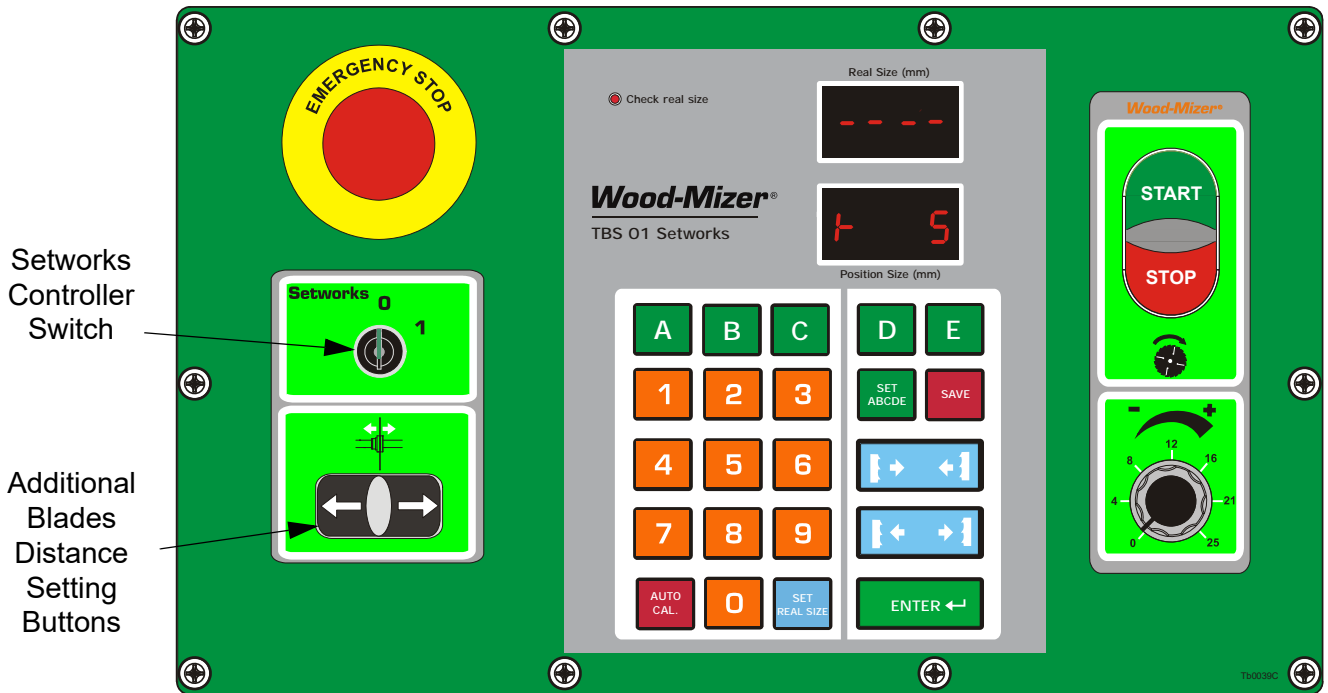

FIG. 3-16EG300 (CE ONLY)

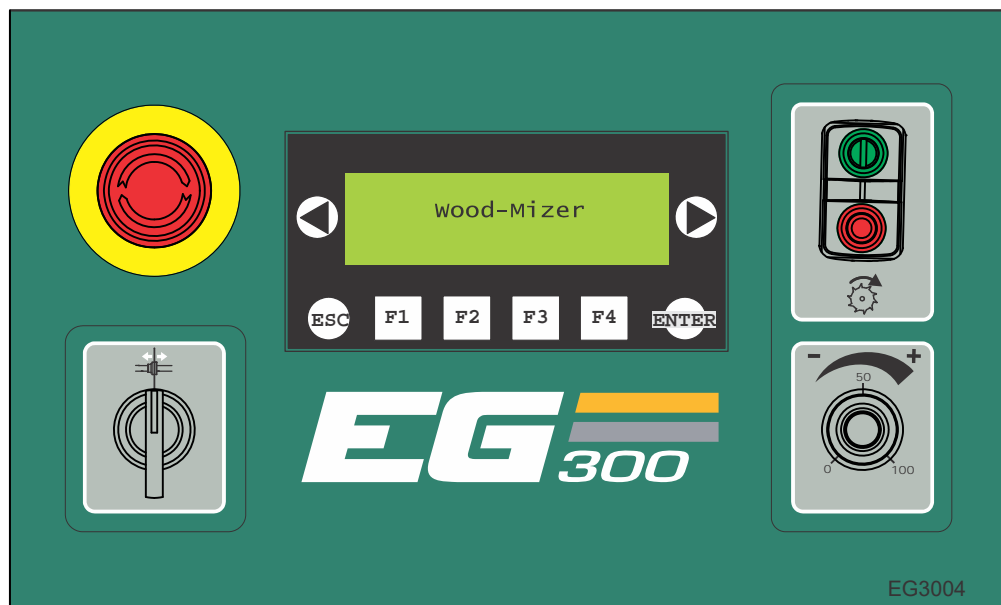

FIG. 3-17 EG300 (U.S. ONLY)

The table below will help you choose suitable thickness and number of spacers for various numbers of blades and distances between them. Use the toolmaker's table to mount the blades on the bushing and then install the bushing assembly to the Edger. You can also mount two bushing assemblies on the shaft, however no more than five blades. To do this, you have to order an additional bushing with spacers.

Ref.	Board Width mm/inch (")	Maximum number of blades	Thickness and number of spacers behind each blade except the last one G [mm]/inch (")				Thickness and number of spacers filling the spacing behind the last blade (up to the nut)					
			G=26,1 1.028"	G=5 0.197"	G=10 0.394"	G=20 0.787"	A - 4,2mm / 0.165"	B - 6,4mm / 0.252"	C - 7,8mm / 0.307"	D - 5,0mm / 0.197"	E - 10,0mm / 0.394"	F - 20,0mm / 0.787"
			Number of spacers									
1	25 / 1"	5	1	0	0	0	1	0	0	1	0	1
2	25 / 1"	4	1	0	0	0	0	0	1	0	1	2
3	30 / 1.181"	4	1	1	0	0	0	0	1	1	1	1
4	35 / 1.377"	4	1	0	1	0	0	0	1	0	0	1
5	40 / 1.574"	4	1	1	1	0	0	0	1	1	0	0
6	25 / 1"	3	1	0	0	0	0	1	0	0	0	4
7	30 / 1.181"	3	1	1	0	0	0	1	0	0	1	3
8	35 / 1.377"	3	1	0	1	0	0	1	0	0	0	3
9	40 / 1.574"	3	1	1	1	0	0	1	0	0	1	2
10	45 / 1.771"	3	1	0	0	1	0	1	0	0	0	2
11	50 / 1.968"	3	1	1	0	1	0	1	0	0	1	1
12	55 / 2.165"	3	1	0	1	1	0	1	0	0	0	1
13	60 / 2.361"	3	1	1	1	1	0	1	0	0	1	0
14	65 / 2.558"	3	1	0	0	2	0	1	0	0	0	0
15	25 / 1"	2	1	0	0	0	0	0	0	1	1	5
16	30 / 1.181"	2	1	1	0	0	0	0	0	0	1	5
17	35 / 1.377"	2	1	0	1	0	0	0	0	1	0	5
18	40 / 1.574"	2	1	1	1	0	0	0	0	0	0	5
19	45 / 1.771"	2	1	0	0	1	0	0	0	1	1	4
20	50 / 1.968"	2	1	1	0	1	0	0	0	0	1	4
21	55 / 2.165"	2	1	0	1	1	0	0	0	1	0	4
22	60 / 2.361"	2	1	1	1	1	0	0	0	0	0	4
23	65 / 2.558"	2	1	0	0	2	0	0	0	1	1	3
24	70 / 2.755"	2	1	1	0	2	0	0	0	0	1	3
25	75 / 2.952"	2	1	0	1	2	0	0	0	1	0	3
26	80 / 3.148"	2	1	1	1	2	0	0	0	0	0	3
27	85 / 3.345"	2	1	0	2	2	0	0	0	1	1	2
28	90 / 3.542"	2	1	1	0	3	0	0	0	0	1	2
29	95 / 3.74"	2	1	0	1	3	0	0	0	1	0	2
30	100 / 3.935"	2	1	1	1	3	0	0	0	0	0	2
31	105 / 4.132"	2	1	0	0	4	0	0	0	1	1	1
32	110 / 4.33"	2	1	1	0	4	0	0	0	0	1	1
33	115 / 4.526"	2	1	0	1	4	0	0	0	1	0	1
34	120 / 4.723"	2	1	1	1	4	0	0	0	0	0	1
35	125 / 4.92"	2	1	0	0	5	0	0	0	1	1	0
36	130 / 5.116"	2	1	1	0	5	0	0	0	0	1	0
37	135 / 5.313"	2	1	0	1	5	0	0	0	1	0	0
38	140 / 5.51"	2	1	1	1	5	0	0	0	0	0	0

**FIG. 3-18**

**NOTE:** The minimum distance between two blades can be 25mm (1"). The maximum distance between the blades can be as follows:

- for 2 blades 140 mm (5.52 ")

# 3

## OPERATION

### *Additional Fixed Blade Option*

- for 3 blades 65 mm (2.56")
- for 4 blades 40 mm (1.57")
- for 5 blades 25 mm (1")

### **Additional Fixed Blade Option**

The edger can be equipped with an additional fixed blade (optional equipment).

**NOTE:** It is necessary to readjust the movable blade limit switch after mounting the additional fixed blade (or blades). To do that, measure the distance from the left edge of the fixed blade arbor to the left edge of the last added blade (see the figure below). Loosen the mounting screws and move the limit switch left, the measured distance.

 **WARNING!** If the limit switch is not readjusted after mounting additional blades, damage to the machine equipment may occur.

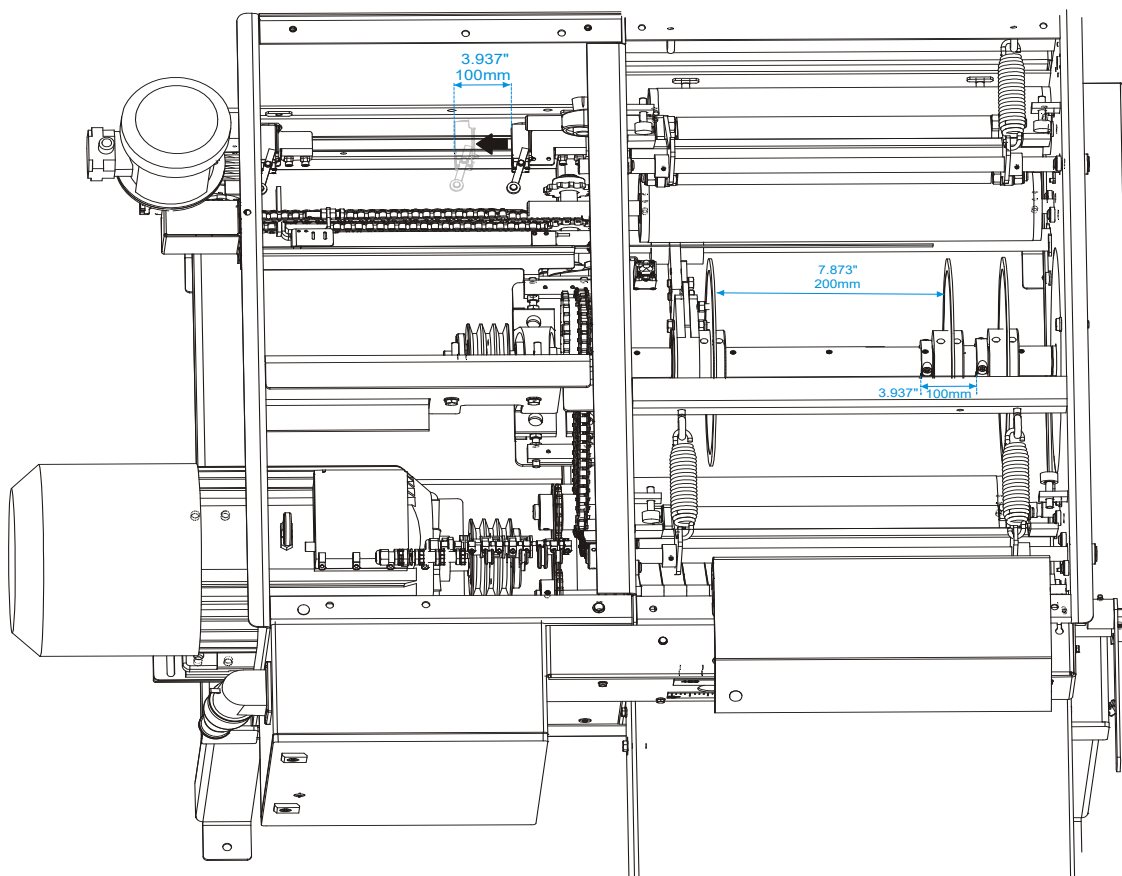

**FIG. 3-19**

## 3.6 Edging Lumber



**DANGER!** Make sure all guards and covers are in place and secured before operating the Edger. Failure to do so may result in serious injury.

**DANGER!** Keep all persons out of the path of moving equipment and boards when operating the Edger or loading boards. Failure to do so will result in serious injury.

**DANGER!** Moving Parts Can Crush and Cut. Keep hands clear. Make sure all guards and covers are in place and secured before operating or towing. Failure to do so may result in serious injury.

**DANGER!** Maintain a clean and clear path for all necessary movement around the Edger and lumber stacking areas. Failure to do so will result in serious injury.



**WARNING!** Always shut off the motor to stop the blade whenever the Edger is not in use. Failure to do so may result in serious injury.

**WARNING!** Always wear eye, ear, respiration, and foot protection when operating the Edger. Failure to do so may result in serious injury.

**WARNING!** Secure all loose clothing and jewellery before operating the Edger. Failure to do so may result in serious injury or death.

After performing the pre-operation check, you are ready to begin edging lumber.

1. Start the machine.
2. Place the board on the infeed table.
3. If one side of the board is edged, place the board with the squared edge against the board guide fence (optional equipment for EG250).

See Figure 3-20. The board guide fence allows guide the board parallel. Release the locking bolt to adjust the board guide fence.

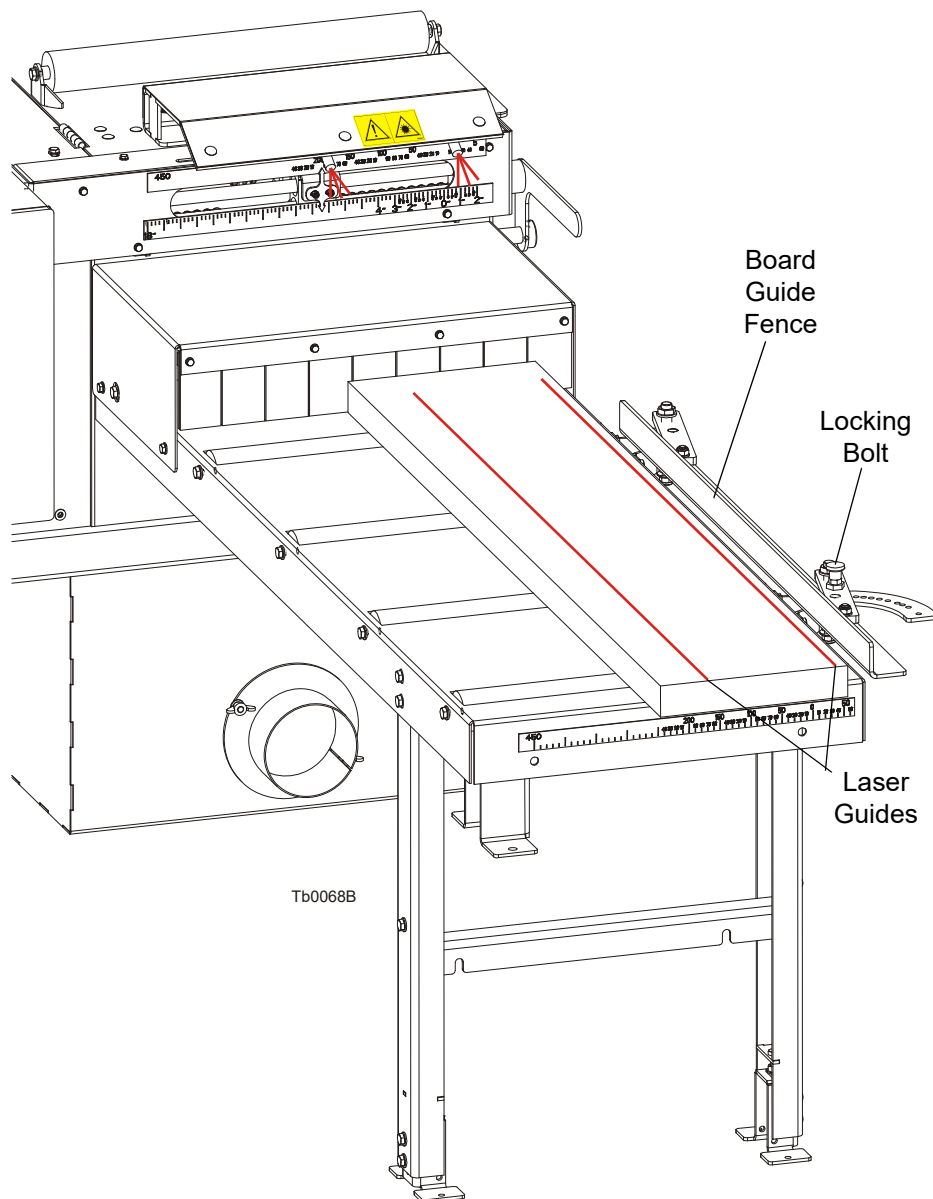

FIG. 3-20

4. Move the blades as desired. If using a fence as a guide, use the corresponding scale to determine the width of the board after edging. The laser will show the path of the blade to help you decide how wide to cut. If edging both sides of the board, use the scale at the top of the edger and or setworks display to determine the width of cut. Again, the lasers show the path of the blades. For instructions how to use Setwork, [See 4.1 Edger Controller Panel](#)
5. Start the blade motor and the feed motor. Set the board feed speed as desired. Push the board into the edger until the feed system takes the board.



**IMPORTANT!** If at any time you need to immediately stop the motor and/or Edger operation, press the Emergency Stop button located at the front or at the rear of the Edger.

6. Repeat the above procedures for all boards to be edged.
7. Shut down the machine when done edging.

## SECTION 4 NETWORKS OPERATION (EG300 CE ONLY)

### 4.1 Edger Controller Panel

See Pic. 4-1.

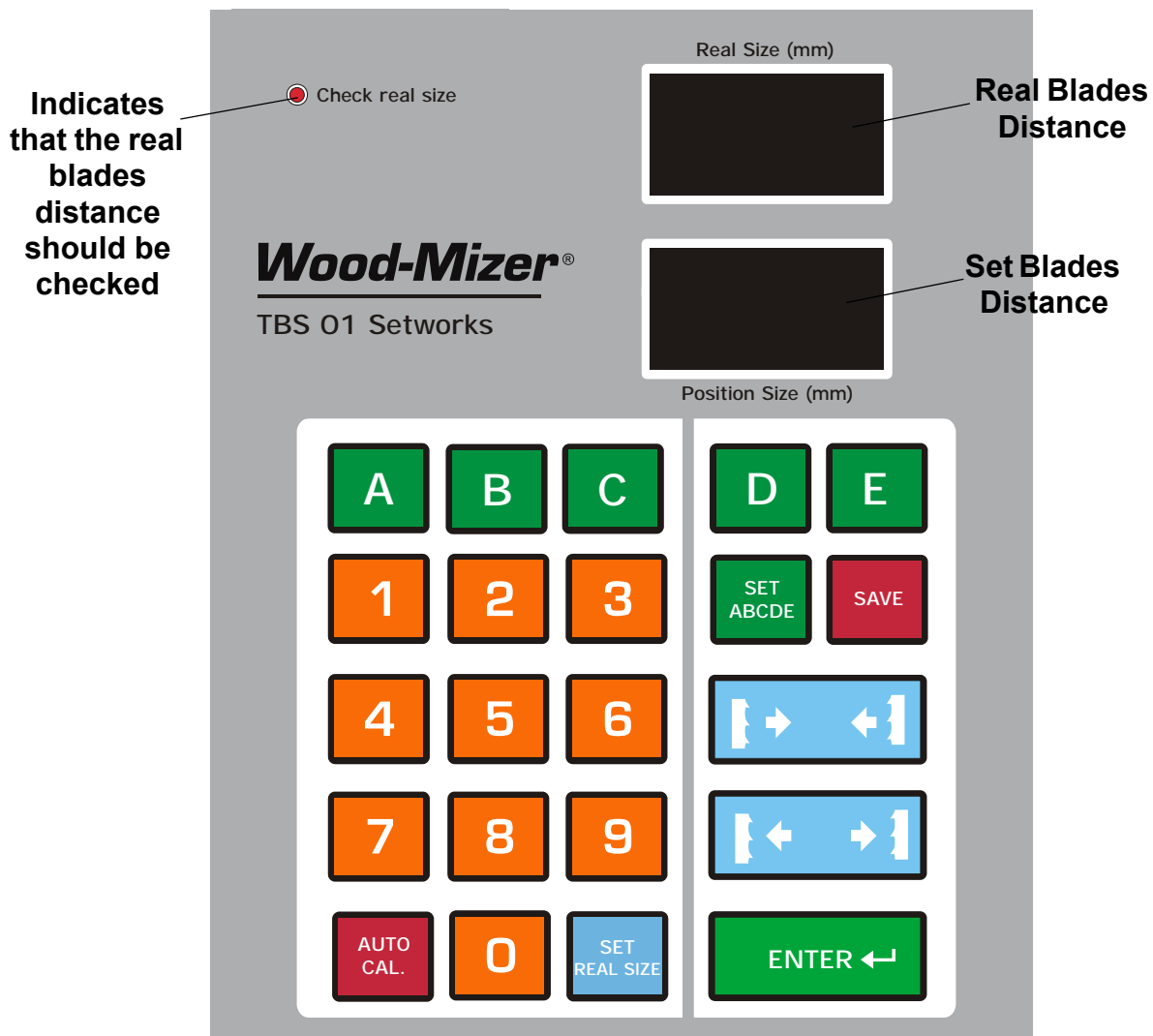

PIC. 4-1



**Descriptions of the control panel buttons:**



A, B, C, D, E - blades width memory buttons.



SET ABCDE - Sets the blades width value to each memory button.



Save - Saves parameters determined by operator.



Blades width manual setting buttons (in/out).



ENTER ← – enters the value to the memory



Auto Mode – Adjustment of the networks automatic calibration parameters. Used for initial calibration and re-calibration if dimensional error occur.



Set Real Size - Sets the real distance between blades. Should be set when “Check real size” indicator lamp blinks.

**IMPORTANT!** Do not use too much force or hard objects to press the buttons. The controller is not water resistant.

## 4.2 Start-up settings of the controller

### 1. Setting the input divider (entered only once, at the first start-up)

- Switch on the controller by turning the main switch to ON position.
- When the text “TBS-01” appears on the display, press and hold  until the divider value appears on the lower right display.
- Enter the correct value of the divider (for Edger the divider value should be **5**).

# 4 NETWORKS OPERATION (EG300 CE Only)

## Start-up settings of the controller

See Pic. 4-2.

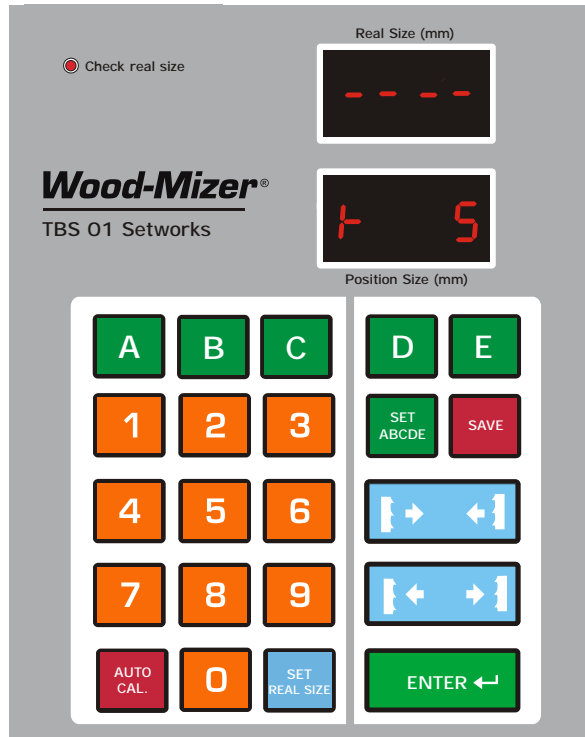



PIC. 4-2

- Press  to save the entered divider value.

### 2. Auto-calibration



This function should be done once a week or in case of: replacement of any component of the blades width setting system, motor or after lubrication of the chains and other moving elements or when significant cutting variances are observed;

- Switch on the edger by turning the main switch to ON position. and wait until the text “TBS-01” disappears.
- Using  buttons set the blades to 180 mm (7.07”) width.
- Press and hold down . After a while - the text “Aut” will appear on the displays. The controller is ready for auto-calibration.

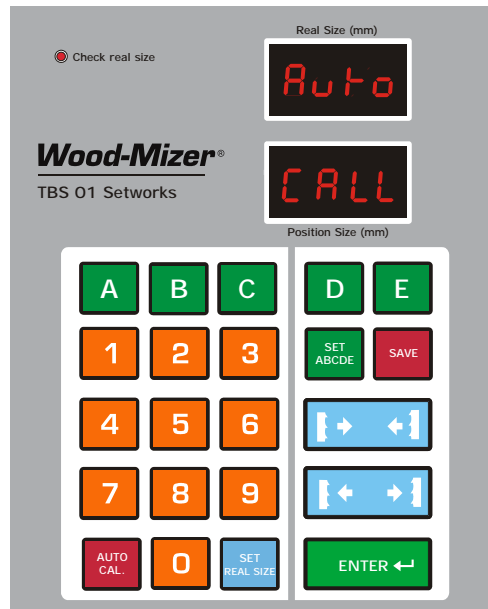
See Pic. 4-3.



PIC. 4-3

- Press  again, the controller successively performs some movements of the blades. After performing the last movement, measure and enter the real head width using the keypad. Confirm by pressing .

### 3. Real blades width entering.

To ensure, that upper display shows the correct blade width, it is necessary to enter real blades width. It must be done on the first start-up and also when:

- significant cutting variances are observed;
- a sudden power disappearance happend when the controller was setting the blade width;
- any repairs to blades drive system was made.

To enter the real blade width:

- Using the scale, set the blades to full measurement (for ex. 250mm (9.842"))
- Press and hold 
- Measure the distance between the blades and make sure if the measured distance is the same as

# 4

## NETWORKS OPERATION (EG300 CE Only)

### Operation, Memory Buttons (A, B, C, D, E)

---

on the scale. If not, [See Section 6.7](#) for scale alignment instructions.

- Enter the distance between the blades without any pauses. Confirm by pressing .



### 4.3 Operation, Memory Buttons (A, B, C, D, E)

After switching-on, the TBS-01 inscription appears on the display, and the networks is ready for operation within a few seconds or after  is pressed.

- To set the blades to any width, enter the blades width value using keypad and press . The blades will automatically move to the entered width value.

- You can also change the blades width manually using .

You can store up to 5 blades width values using the memory buttons.

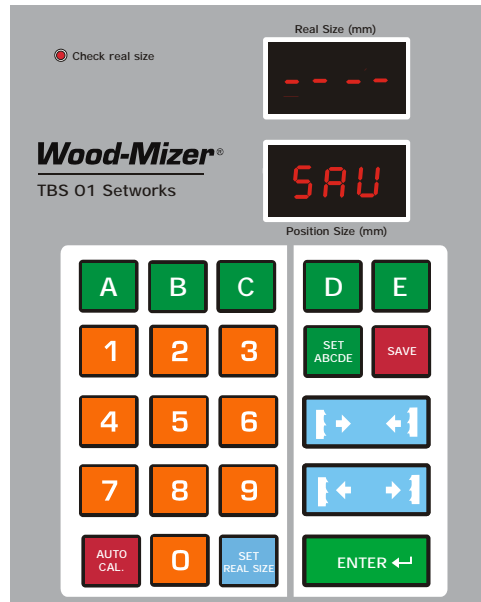

- To store the width value using the memory button, press and hold . On the upper display the “ABC” will appear. Press the memory button (A, B, C, D or E), enter the width value and confirm by pressing . Perform the same procedure for other memory buttons. Press  to exit this function.

See Pic. 4-4.







PIC. 4-4

- To use the stored value, press the required memory button and confirm by pressing . The blades will move to the stored width.

**NOTE:** If during normal operation the “Check real size” lamp start blinking, press and hold the  button. Measure and enter the distance between the blades with an accuracy of 0,1 mm (0.00394"). For example: if you want to enter 102mm - press **1-0-2-0** without any pauses and confirm by pressing .

## 4.4 Networks Malfunction

PROBLEM	CAUSE	SOLUTION
<p><b>Networks does not work.</b></p> <p>When performing a program, the controller disengages the drive mechanism and the display shows:</p>  <p><small>Saw position (mm)</small> 000 <small>Board Thickness (mm)</small> ErP</p>	Magnet sensor improperly adjusted	Align the magnet sensor as shown in figures 4-5 and 4-6. Calibrate the controller. <a href="#">See Page 4-3.</a>
<p>When performing the auto-calibration, the controller disengages the drive mechanism and the display shows:</p>  <p><small>Saw position (mm)</small> Auto <small>Board Thickness (mm)</small> ErP</p>		Enter the real distance between the blades. <a href="#">“Entering Real Blade Height Dimensions” on page 5</a>
<b>Networks calculates dimensions incorrectly.</b>	Improper input parameters	Check the input divider. ( <a href="#">“Setting the input divider (entered only once, at the first start-up)” on page 2</a> and <a href="#">“Real blades width entering.” on page 4</a> ). - Perform the auto-calibration procedure. <a href="#">“Auto-calibration” on page 3.</a>
<b>Blades do not stop at the required width, but continues its movement until limit switch is activated.</b>	Controller not calibrated	Check the input divider. Perform the auto-calibration procedure.
<b>Networks stops.</b>	Blades width sensor signal is bad.	<ul style="list-style-type: none"> <li>- Check the connections between the blades width sensor and the controller.</li> <li>- Check if the sensor or the magnetic strip is not loose.</li> <li>- Check if the connections to the blades setting system contactors are correct and not loose.</li> </ul>
<b>During manual blades movement, the upper display shows a negative value.</b>	Networks not calibrated	Perform the auto-calibration procedure.

When pressing  during normal operation or when attempting to save the program (using  button), the upper display shows horizontal dashes.

The blades width limit would be exceeded if the requested blades movement was performed.

Try to enter different blades width value.

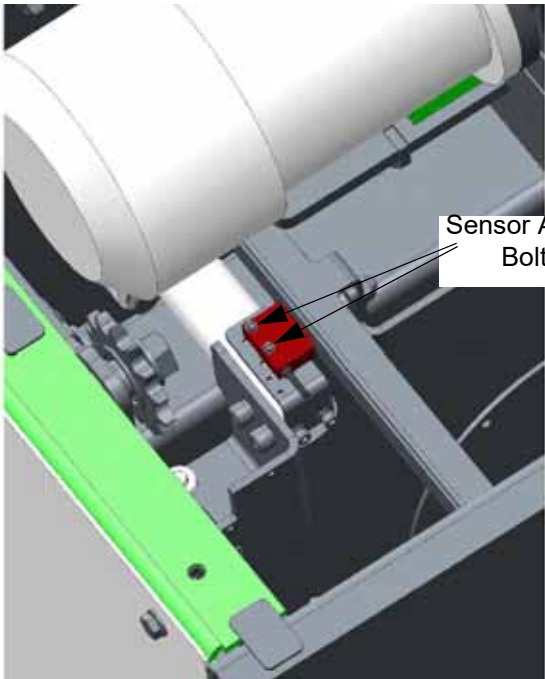

FIG. 4-5

# 4

## NETWORKS OPERATION (EG300 CE Only)

### Setworks Malfunction

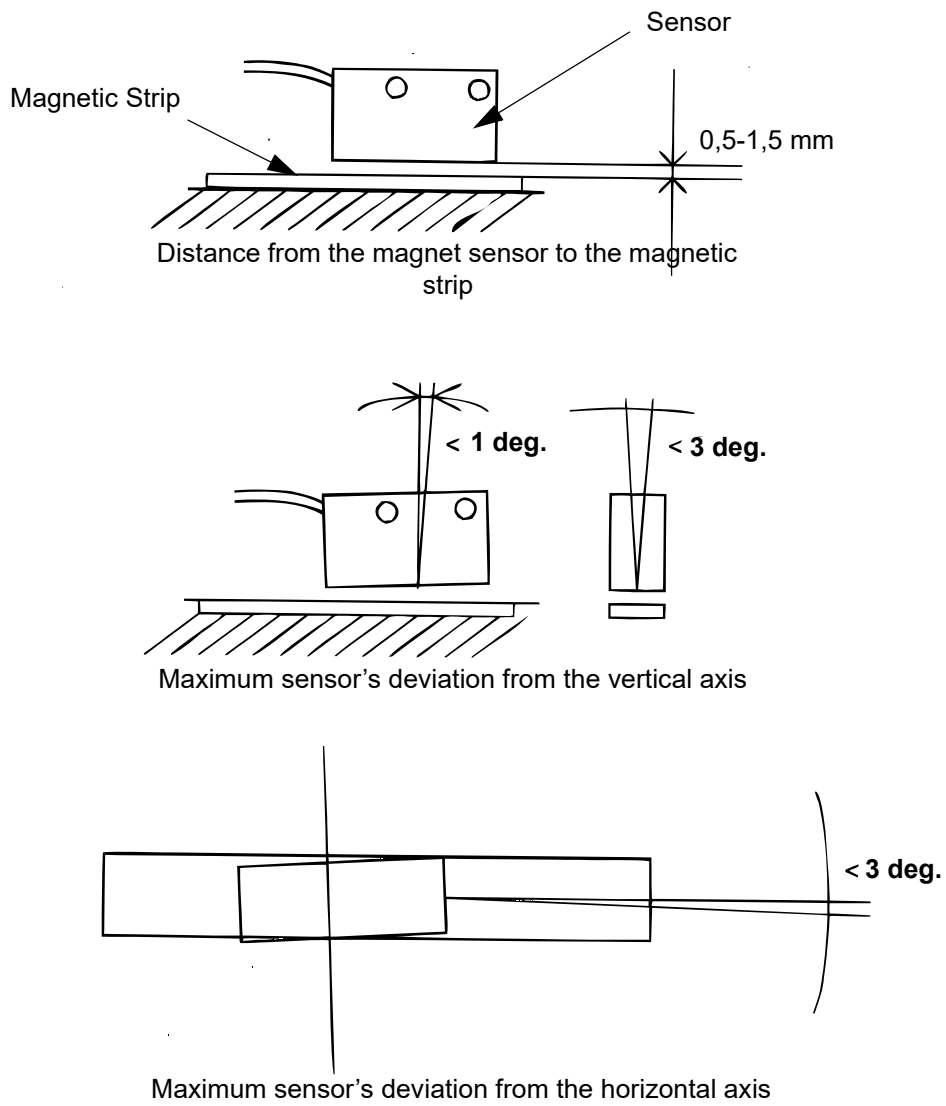

FIG. 4-6



## SECTION 5 NETWORKS OPERATION (EG300 U.S. ONLY)

### 5.1 Networks (Optional - U.S. Version)

The Networks option allows you to program eight positions for the blades and adjust to those positions by pushing a single button. For Networks to be operational, the power to the machine must be on and the green power indicator on the operator control illuminated.

#### 5.1.1 Networks Start-up

See **Figure 5-2**. When the power to the machine is turned on, the Networks display flashes the company name first. After a short delay, you may see an Error #203 displayed. This is normal during start-up as the display waits for the PLC to boot up. Once communication with the PLC is established, the display will return to the first screen and then show the PLC and Display software versions. This information should be supplied to Customer Service when requesting service.

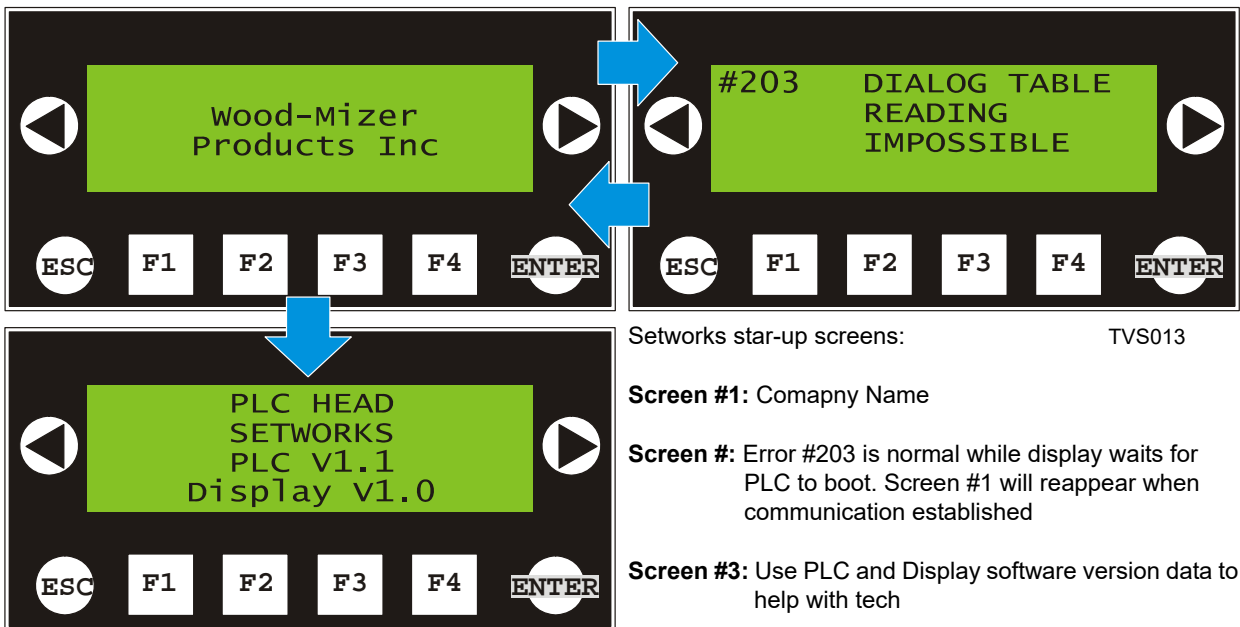

FIG. 5-2

## 5 Networks Operation (EG300 U.S. Only)

Networks (Optional - U.S. Version)

See Figure 5-3. After the Networks display scrolls through the start-up screens, the Main screen will be displayed. Depending on how the control is programmed, the Main screen will display in one of three unit options: Imperial Fractions, Imperial Decimals or Metric.

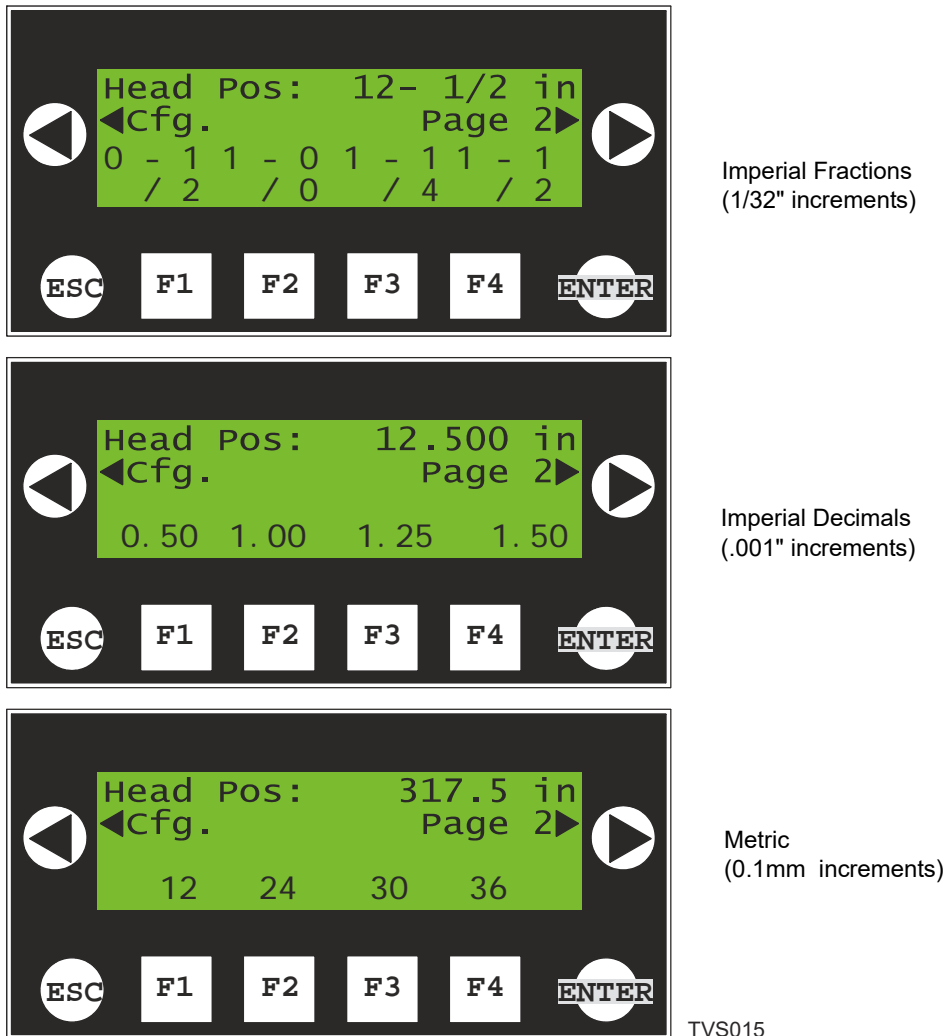

FIG. 5-3

The Main screen displays the distance between blades and the first set of four Presets. Push the corresponding 'F' button to select a preset. The saw heads will move until the blades are that distance apart. Push the right arrow labeled 'Page 2' to scroll to the second set of four Presets.

**NOTE:** If the heads are required to move in to reach the desired preset value, they will travel in past the preset target and then move out to the target. This compensates for backlash in the mechanical system.

**5.1.4 Select Unit Of Measure**

See **Figure 5-5**. Push the left arrow labeled 'Cfg.' to enter the Configuration menu. Use the F1, F2 or F3 buttons to select the unit of measure you wish to use. The units currently selected will be labeled 'ON'. Push 'ESC' to return to the main screen.

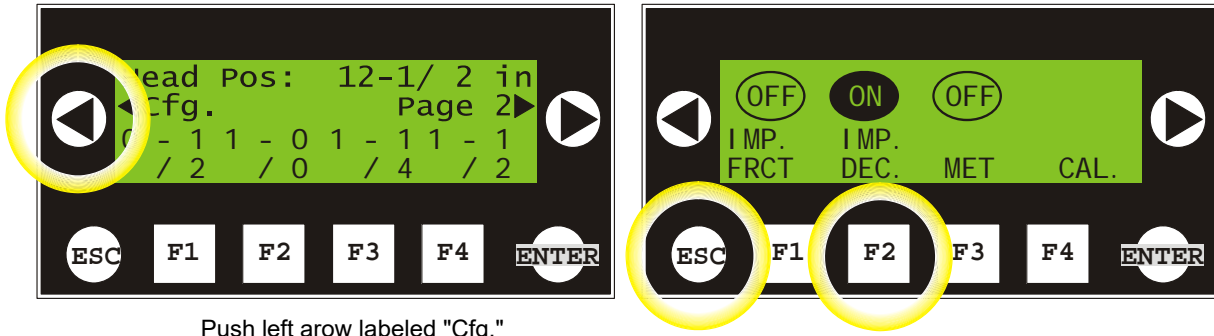

Push left arrow labeled "Cfg."

Push "F1" for Imperial Fractions, "F2" for Imperial Decimals or "F3" for Metric units. The unit selected will show "ON" above the button label. Push ESC to return to the main screen.

TVS016

**FIG. 5-5**

### 5.1.6 Calibrate Blades Position

After the Networks option is installed or if inaccurate position of the blades is observed, calibration of the Networks control with the saw head position may be required.

Adjust the blade positions so the blades are an easy-to-measure distance from each other. **NOTE:** Because the Networks control calibration values are limited to integers between 0 and 9, the distance between the blades should be set less than 9.999 inches in Imperial units or 999.9mm in Metric units. When adjusting the head positions, be sure to move the heads in past the target position and then out to compensate for any backlash in the mechanical system.

See **Figure 5-7**. Push the left arrow labeled 'Cfg.' to enter the Configuration menu. Push the F4 button to enter the Calibration menu. If using Imperial Fractions or Imperial Decimal units, the Calibration menu will display in inch increments. If using Metric units, the menu will display increments in millimeters.

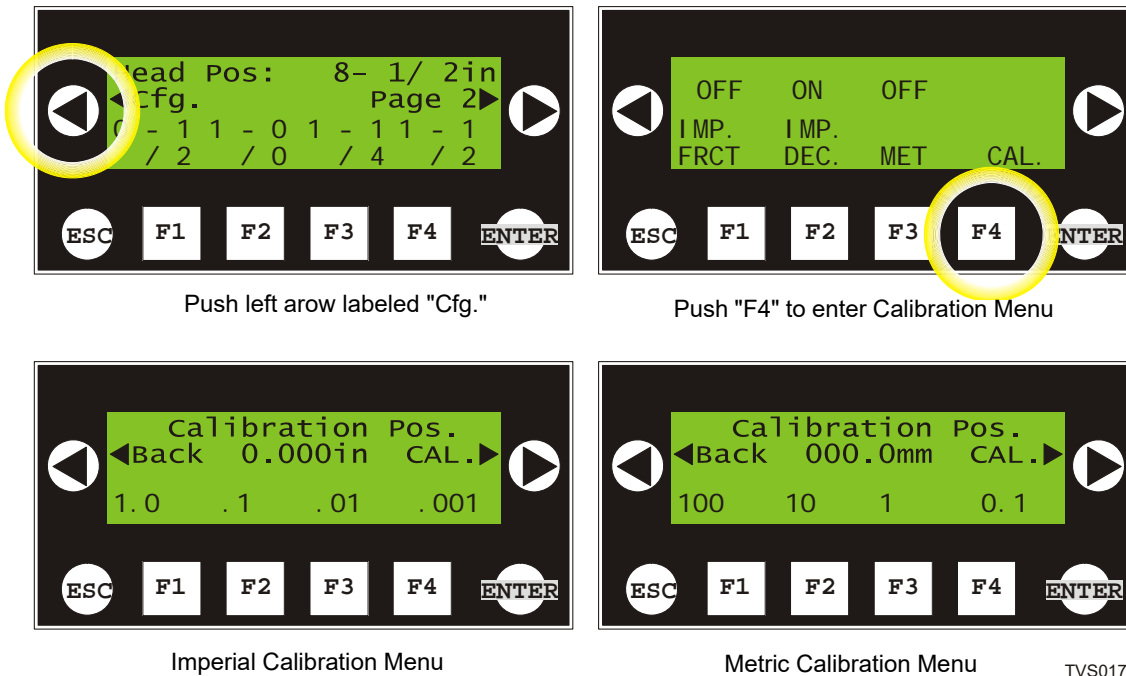

**FIG. 5-7**

Use the F1 - F4 buttons to scroll each value as desired. When the value reaches '9' pushing the button again will return the value to '0'. Adjust the values until the Calibration Position equals the actual measurement between the blades.

To save the Calibration Position setting, push the right arrow button labeled 'CAL.' To exit without changing the calibration, push the left 'BACK' arrow. Push the Back button to return to the Configuration screen or the 'ESC' button to return to the Main screen.

**5.1.8 Adjust Preset Values**

See Figure 5-9. To enter different values for each preset, push the right arrow button labeled 'Page 2' from the Main screen. Push the right arrow again to enter the presets Setup menu. Push the left arrow 'Back' button to return to the Main screen.

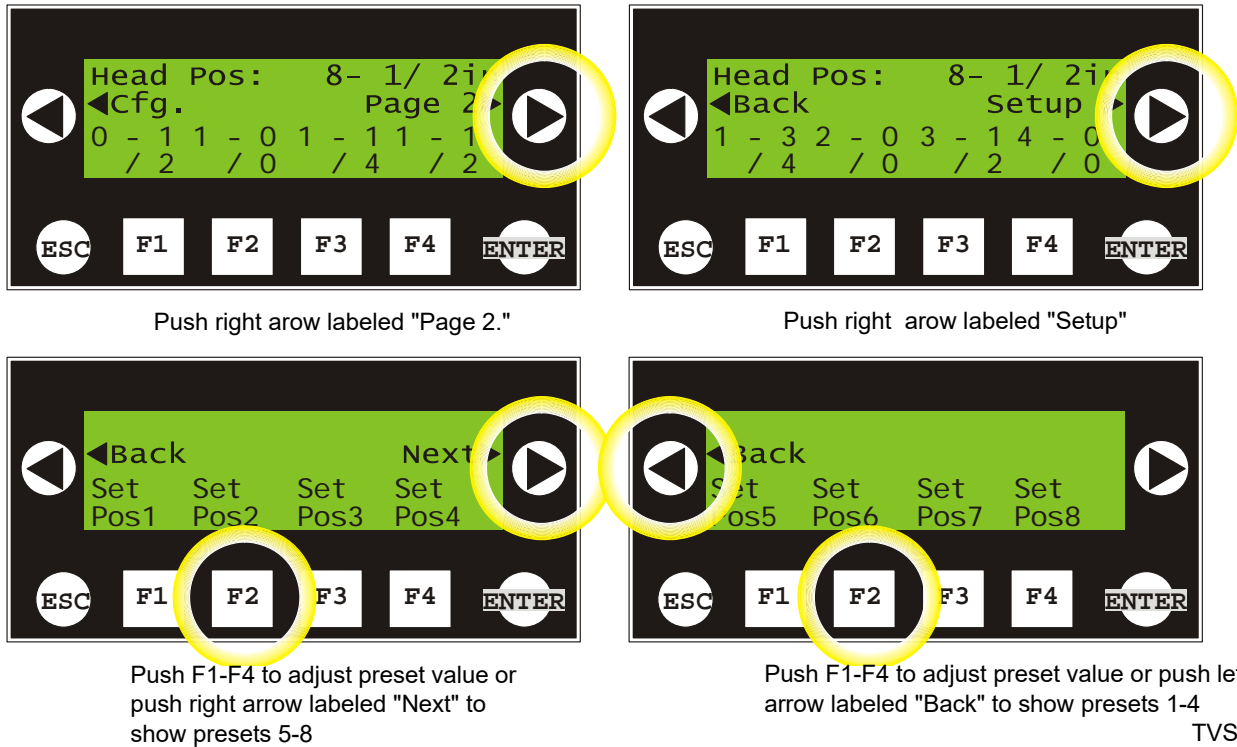

**FIG. 5-9**

See Figure 5-10. In the Setup menu, select the corresponding 'F' button for the value you wish to set. Push the right arrow 'Next' button to scroll to Presets 5-8. Once you select a Preset to change, the Position Set menu will appear.

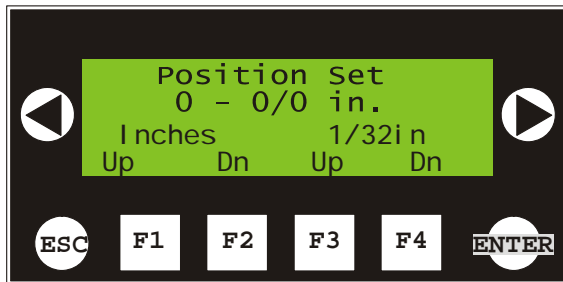

**Imperial Fractions:**

Use F1 & F2 to adjust inches up or down;  
Use F3 & F4 to adjust fraction up or down

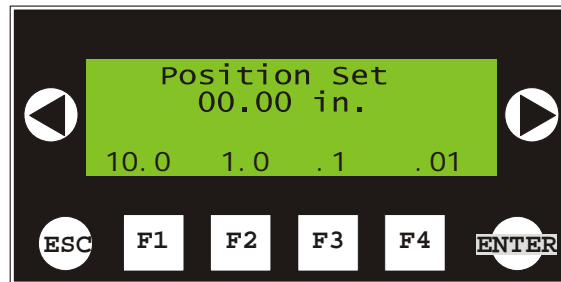

**Imperial Decimals:**

Use F1 to adjust tens value; F2 to adjust ones;  
F3 to adjust tenths; F4 to adjust hundredths

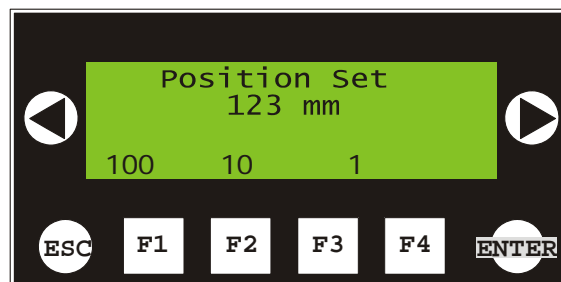

**Metric:**

Use F1 to adjust hundreds value; F2 to adjust tens;  
F3 to adjust ones

TVS019

**FIG. 5-10**

**Imperial Fractions:** Use the F1 and F2 buttons to scroll the whole inch by a value of one up or down each time the corresponding button is pushed. Use F3 and F4 to adjust the fraction value by 1/32 inch up or down each time the corresponding button is pushed.

**Example:** To set the value to 1-1/4, press F1 once and F3 eight times.

**Imperial Decimals:** Use the F1 button to scroll the tens value in increments of 1, F2 to scroll the ones value, F3 to scroll the tenths and F4 to scroll the hundredths.

**Example:** To set the value to 1.25, press F2 once, F3 twice and F4 five times.

**Metric:** Use the F1 button to scroll the hundreds value in increments of 1, F2 to scroll the tens value, and F3 to scroll the ones.

**Example:** To set the value to 25mm, press F2 twice and F3 five times.

Push 'ENTER' to save the preset value and return to the Setup menu. Push the 'Back' button to scroll back through the menus or push 'ESC' to return to the Main screen.

## SECTION 6 MAINTENANCE & ALIGNMENT

### 6.1 Replacing the Blades

1. Replace the blades as necessary. Dull blades will cause the motor to work harder and will result in decreased cut quality and accuracy. Blade life will vary depending on maintenance of machine, operator, species of wood being sawn, and condition of wood being sawn.



**DANGER!** Before changing the blades, make sure the blade mounting arbors have come to a complete stop and the motor is shut off completely. Turn the main switch to "0" position and disconnect the power cord. Failing to do so can cause serious injury.



**WARNING!** Always wear eye, glove and foot protection when handling saw blades.

2. To access the blades, unbolt and open the blade housing cover.
3. With the blade drive shaft secured, use the provided spanner wrenches to loosen the locking nuts on the blades.
4. Remove the bearing/adaptor sleeve assembly along with the side cover. To do this, first unbolt and remove the bearing guard. Then remove the locking bolt and the nuts securing the side cover to the machine body.

See Figure 6-1.

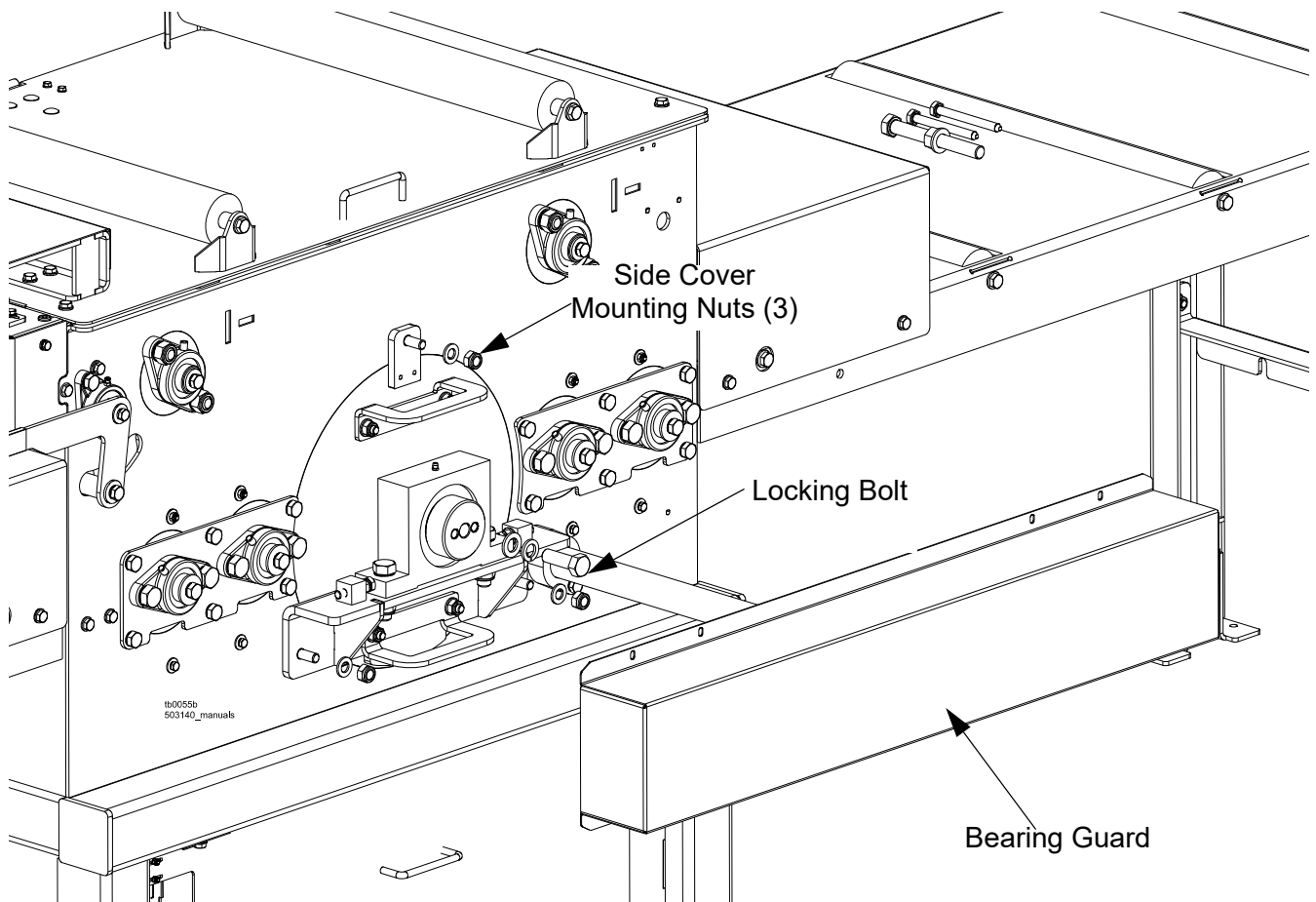

**FIG. 6-1**

5. Next, screw in the provided M10x100 bolts by hand until you feel resistance. Then use a wrench to screw in the bolts evenly until the bearing unit with the side cover slide off the blade shaft.



See Figure 6-2.

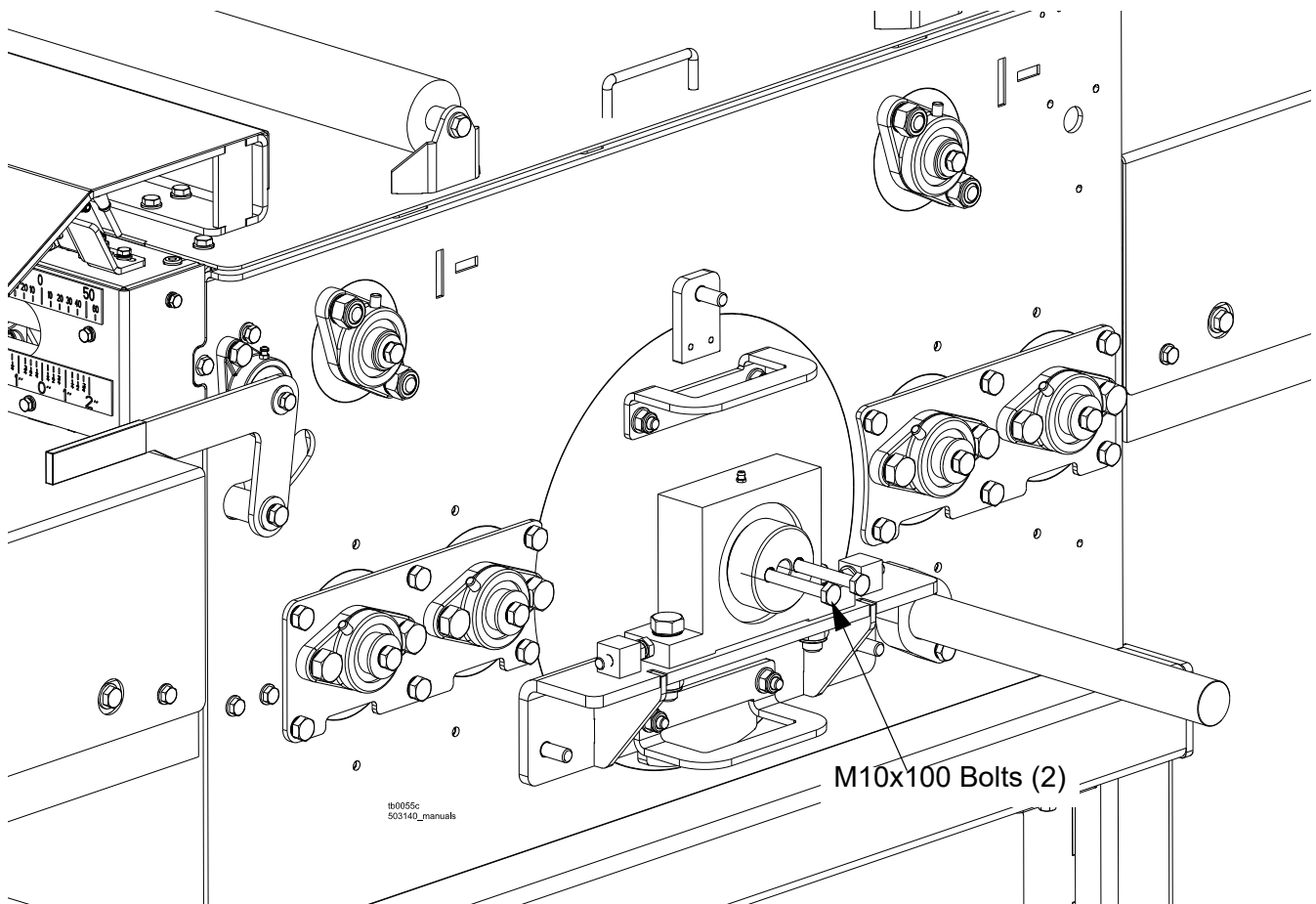

FIG. 6-2

6. Then remove the blade (blades) from the shaft. To do this, remove the fixed blade locking nut using the provided spanner wrenches and next remove the fixed blade. Loosen the two allen screws on the fixed blade arbor and remove the arbor from the shaft.
7. Unscrew and remove the movable blade locking nut. Slide the movable blade from the shaft.

See Figure 6-3.

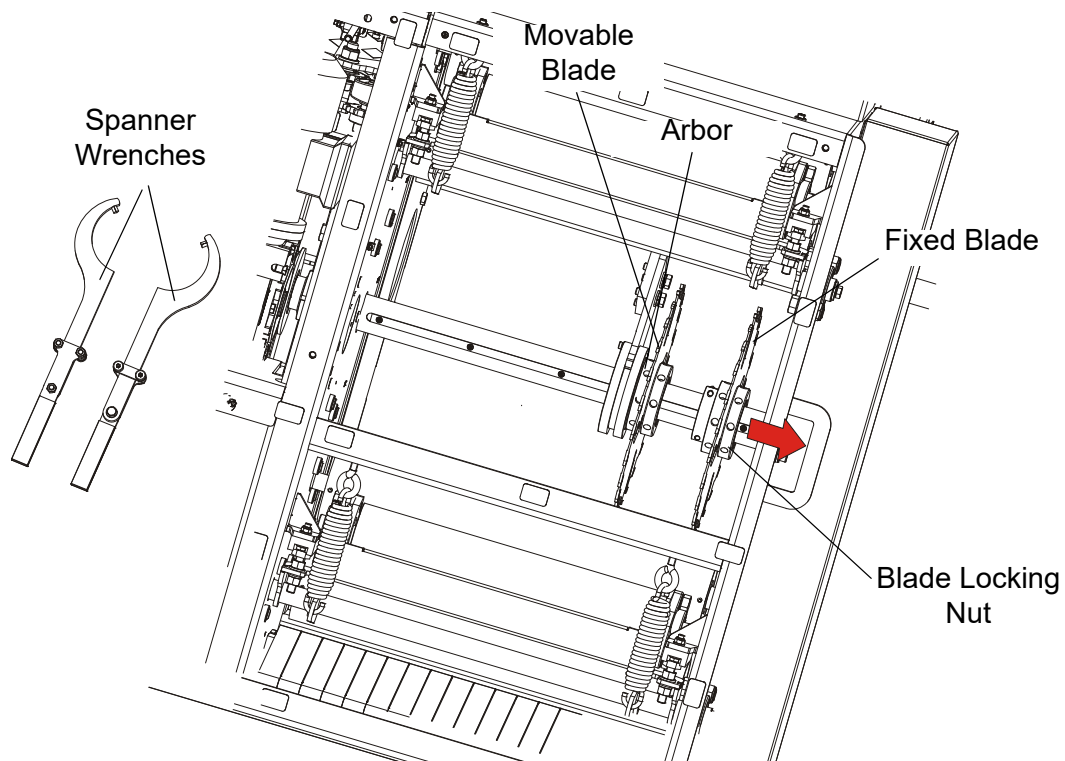

FIG. 6-3

8. Apply an anti-seize lubricant to the face of the arbor and to the face and threads of the blade locking nut.
9. Install a new or resharpened blade to the shaft and position it next to the movable blade arbor. Align the hole in the blade with the pin in the arbor. Loosely reinstall the movable blade locking nut.
10. Reinstall the fixed blade arbor to the shaft. Install a new or resharpened blade, and loosely reinstall the fixed blade locking nut.
11. Reinstall the bearing unit together with the side cover. Screw in the provided adapter sleeve installation bolt (M16x140 bolt with the nut and washer on it) by hand until you feel resistance. Next, using a wrench, turn the nut on this bolt until you feel strong resistance and the bearing unit together with the side cover are in place.

See Figure 6-4.

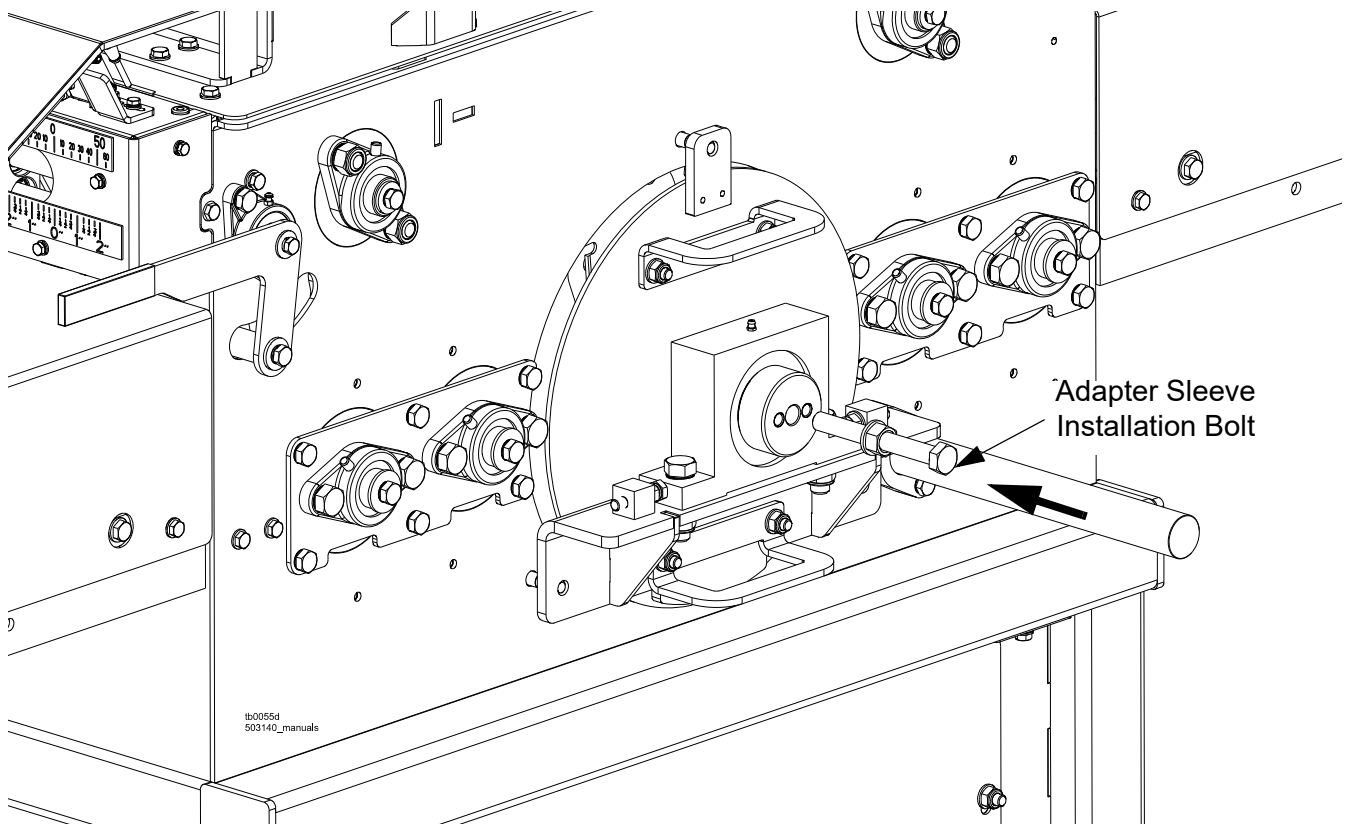

FIG. 6-4

12. Remove the adapter sleeve installation bolt and reinstall the locking bolt.
13. With the blade drive shaft secured, use the spanner wrenches to tighten the blade locking nuts all the way.
14. Align the blades. [See Section 6.7.](#)
15. During alignment, the blade arbor allen screws should be tightened to secure the blade assemblies in place.
16. After alignment, be sure to close and secure the blade housing cover and install the bearing guard.

## 6.2 Tensioning the Belts



**DANGER!** Always shut off the motor and allow all moving parts to come to a complete stop before removing any guards or covers. Failure to do so will result in serious injury.

Before tensioning the belts, make sure the motor is shut off completely and the main switch is in "0" position. Disconnect the power cord. Failing to do so can cause serious injury.



**WARNING!** Do not for any reason adjust the motor drive belts with the motor running. Doing so may result in serious injury.



**CAUTION!** Never apply belt dressing as this will damage the belt and cause early failure.

1. Check the drive belts for wear every 8 hours of operation and more frequently during the first 24-48 hours of operation. Tension or replace as necessary. Tension should be 14mm (0.551") deflection with 4 kG (40N) of force for new belts or 14mm (0.551") deflection with 2,7 kG (27N) of force for used belts. In case of damage of one belt, we recommend to replace all three belts.

To tension the drive belts:

- Unbolt and open the gearbox housing cover.
- Locate and loosen the mounting bolts which secure the motor plate to the edger weldment.
- Using adjustment bolts, tension or loosen the belts. Be sure to adjust the bolts evenly so the motor remains in alignment.



**CAUTION!** Do not over tighten the drive belt as it can cause premature belt and/or bearing failure.

**CAUTION!** Do not under-tighten the drive belt as it can cause one or all of the following damages: slippage of the belt on the drive pulley, binding or fetching up of the blades while in the cut, damage or bending of blades.

- Retighten the motor plate mounting bolts.
2. Close the gearbox housing cover and use the existing bolts to secure.

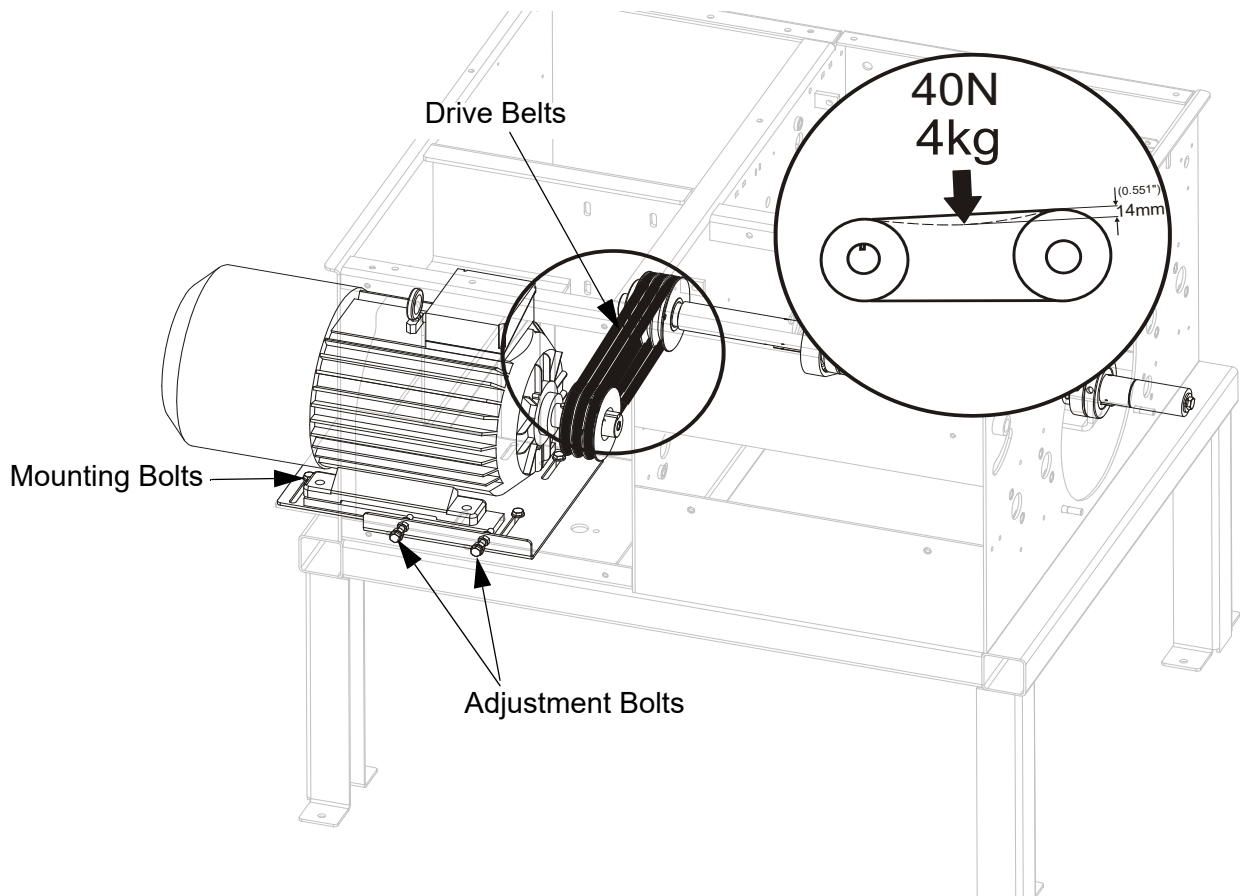

FIG. 6-4

## 6.3 Tensioning the Chains

### Board Feed Drive Chains

Check the board feed drive chains for tension every 40 hours of operation and tension as necessary.

40

**See Figure 6-5.** To tension the drive chains, unbolt and open the gearbox housing cover.

- Loosen the chain tensioner socket bolt.
- Turn the tensioner to tighten the board feed chain.
- Tighten the the chain tensioner socket bolt.

- Retighten the gearbox mounting bolts and close and secure the gearbox housing cover.

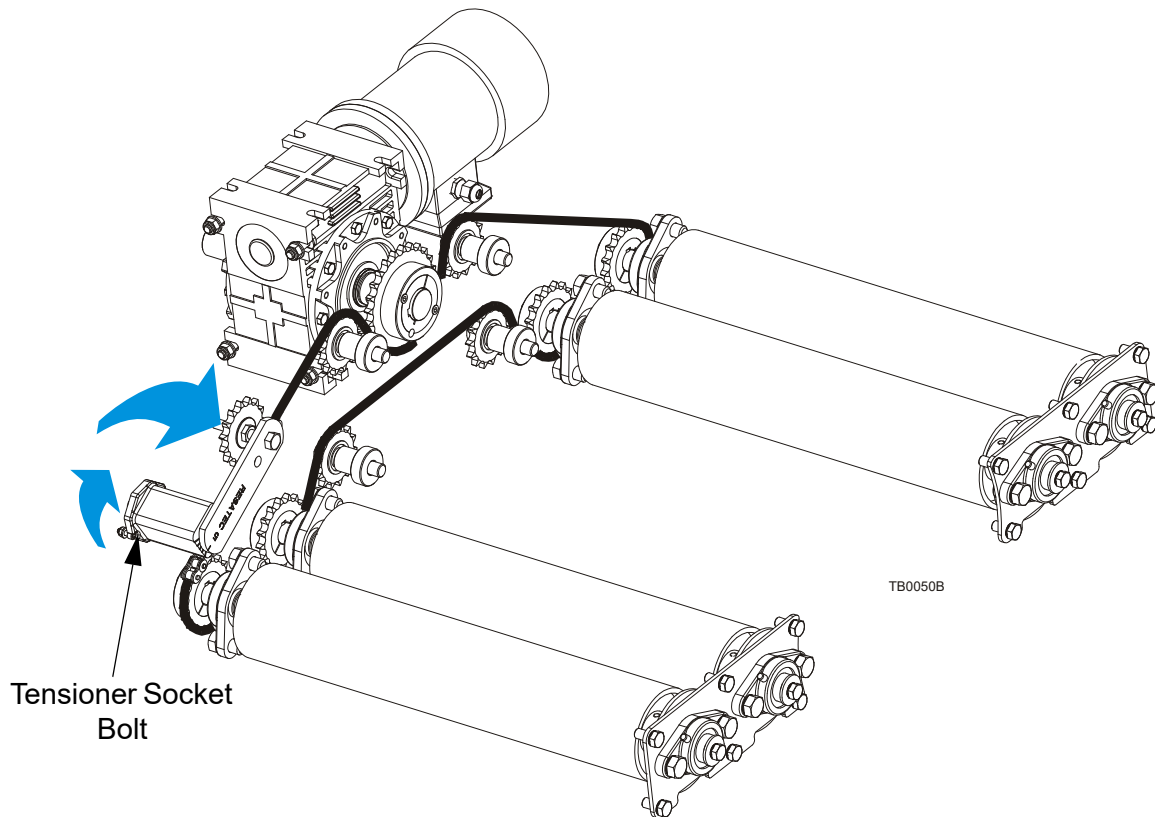

FIG. 6-5

### Blade & Laser Positioning Chains

100

Check the blade and laser positioning chains for tension every 100 hours of operation and tension as necessary. The chains should have approximately 15mm (0.59") of slack. **NOTE:** The chain tension affects cutting accuracy.

**See Figure 6-6.** To tension the blade positioning chain, unbolt and open the gearbox housing cover. Loosen the locking bolts. Using adjustment bolts, tension the chain. After that, tighten the locking bolts.

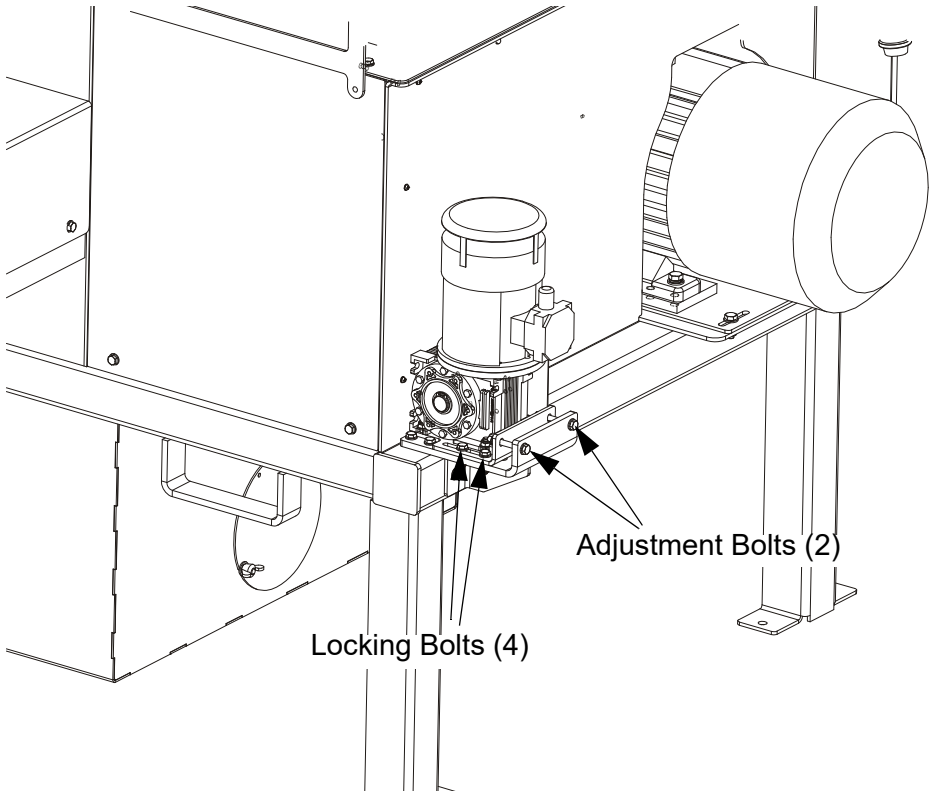
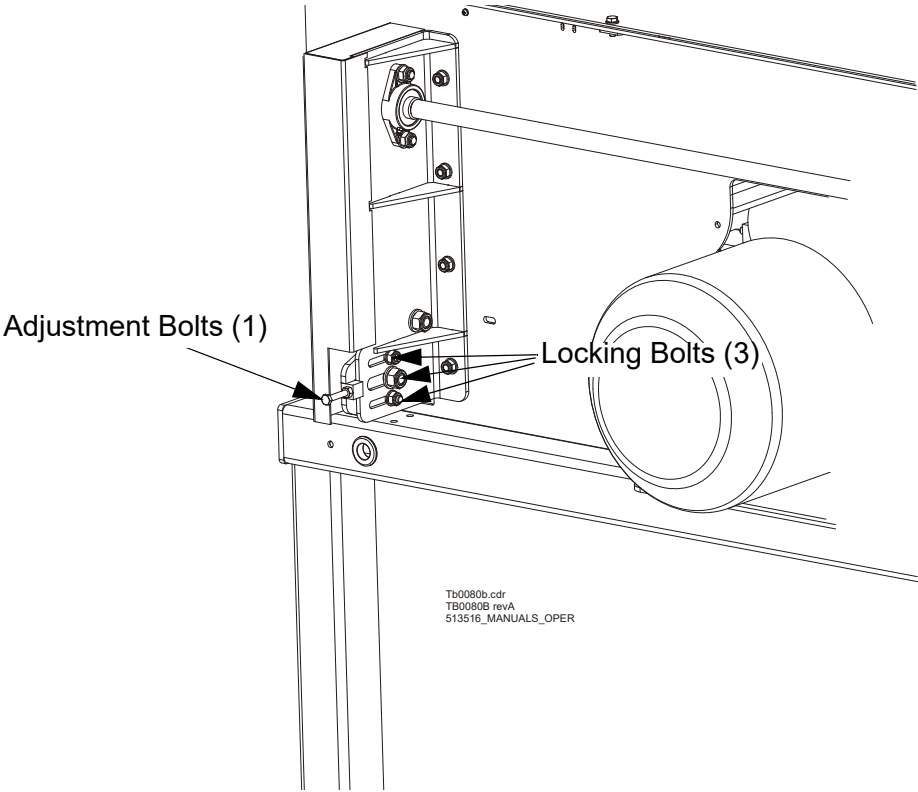

FIG. 6-6 EG300



Tb0080b.cdr  
TB0080B revA  
513516\_MANUALS\_OPER

FIG. 6-6 EG250

See **Figure 6-7**. To tension the laser positioning chain (EG300 only), unbolt and remove the blade housing cover. Loosen the sprocket axle mounting bolt. Using adjustment bolt, tension the chain. After that, tighten the sprocket axle mounting bolt.

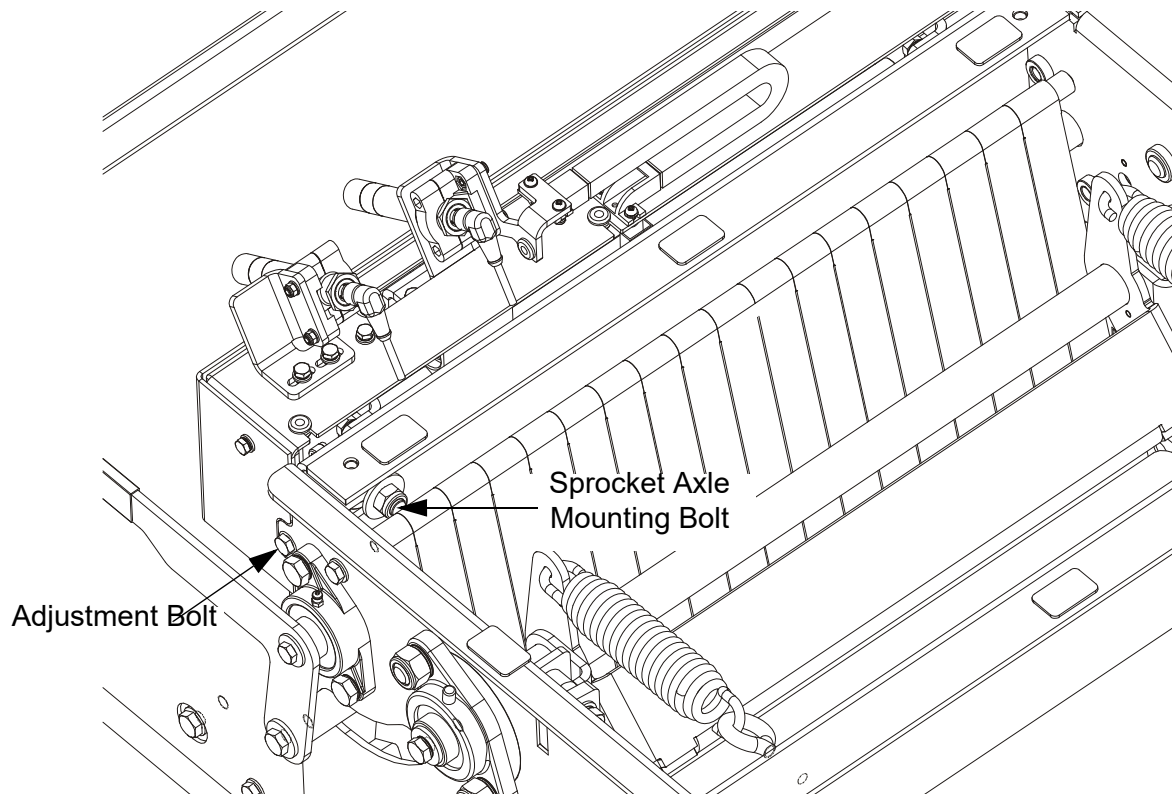

**FIG. 6-7 EG300**

## 6.4 Checking the Rollers

1. Check the hold-down rollers every 8 hours of operation. Remove any dirt or debris from the rollers. Make sure they spin freely, without much play. Replace the spring-loaded hold-down rollers as needed.
2. Check the feed rollers every 8 hours of operation. Clean any debris or sap buildup from the rollers with a wire brush. Replace the feed roller bearings if there is any play in the rollers.

## 6.5 Lubrication

1. Clean any debris from the blade drive shaft and every 8 hours of operation. Use a soft cloth to apply a dry graphite daily to ensure resistance-free motion and to prevent surface corrosion.
2. Lubricate the blade shaft bearings every 200 hours of operation with one to two pumps of lithium-based grease such as Shell Alvania No. 3. Do not overgrease.
3. Lubricate the anti-kickback shaft pivots every 200 hours of operation with a high-quality lithium-based grease such as Shell Alvania No. 3.



4. Lubricate the hold-down roller bearings every 200 hours of operation with a high-quality lithium-based grease such as Shell Alvania No. 3.
5. Apply anti-seize lubricant to the surfaces and threads of the blade arbors and locking nuts every blade change ([See Section 4.1](#)).

## 6.6 Anti-Kickback Fingers Maintenance

This machine has the potential for kick-backs. Kick-backs can cause the board to be suddenly and uncontrollably hurled towards the operator. Such action can result in severe injury or death.

If you are working with frozen boards or with boards that have protruding knots, the chance of kickbacks is increased.

The infeed opening of the Edger is equipped with anti-kickback fingers to help prevent kickback from occurring. To maintain the safety of your Edger, periodically inspect the machine to ensure all anti-kickback fingers are intact and undamaged and have a sharp point. Missing or damaged parts can affect the safety of the machine operator or bystanders and should be replaced immediately. Do not sharpen the anti-kickback fingers! If they are dulled, replace them with new ones.



**DANGER!** Always ensure that there is a sharp point on the anti-kickback fingers before each use of the Edger.

Be sure anti-kickback fingers are free from obstruction and are in a downward position with lever released. Failure to do so may result in serious injury.

## 6.7 Alignment



**WARNING!** Before performing service near moving parts such as blades, pulleys, motors, belts and chains, first turn the main switch to the "0" position and disconnect the power cord.



**WARNING!** Coastdown Required. Always shut off the motor and allow all moving parts to come to a complete stop before removing any guards or covers. Do NOT operate with any guards or covers removed.



**WARNING!** Visible and/or invisible laser radiation. Avoid eye or skin exposure to direct or scattered radiation.



**DANGER!** The operator must not for any reason perform any laser maintenance or repair work.

### Fixed Blade, Laser and Fence Alignment

1. The position of the fixed blade is adjusted by loosening the blade locking nuts just sufficiently to be able to slide the blade on the shaft.
2. Set the fence to the maximum width, so that the pin is secured in the first hole.

## 6

## Maintenance &amp; Alignment

## Alignment

3. Place a 60mm wide bar along the outside edge of the blade and so that the bar is aligned with the 0 mark on the scale and the bar meets the fence. [See Figure 6-8.](#)
4. Tighten the blade clamps and check the alignment again.
5. Check if the fixed blade laser indicates the left edge of the bar. If not, loosen the laser mounting bolts and slide the laser as necessary. Next, tighten the mounting bolts.

See Figure 6-8.

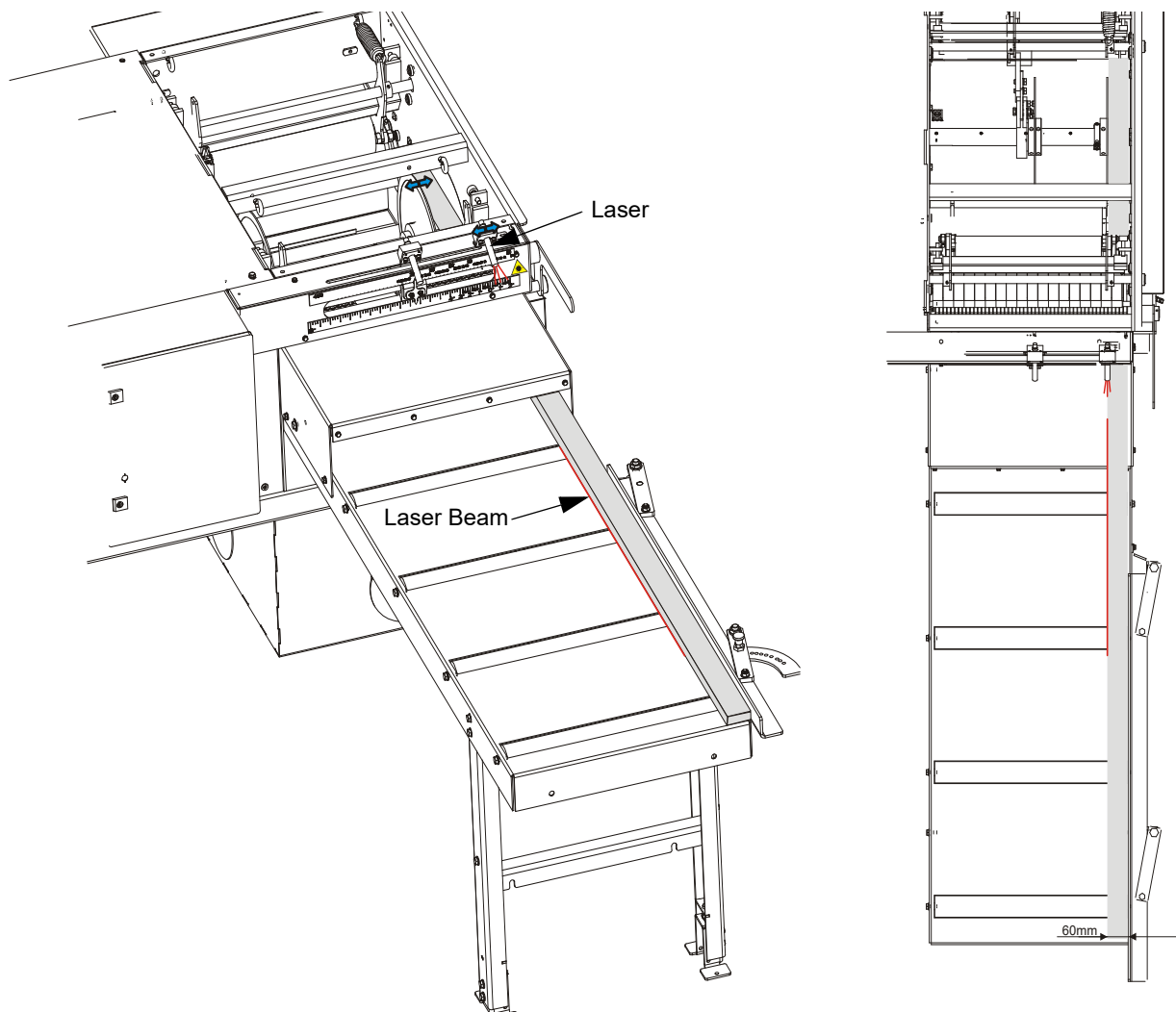



FIG. 6-8

### Adjustable blade and its laser indicator alignment

6. To position the adjustable blade, set the blade to 200mm (7.874") using  buttons or the scale (EG300) or turn the setworks handle as necessary, and release the pin into the appropriate labeled hole (EG250). Measure from the inside of the fixed blade to the inside of the movable blade. If necessary, loosen the movable blade arm and slide the blade assembly on the shaft until the blades are 200mm (7.874") apart. Retighten the blade arm. If the adjustable blade has been aligned, it is necessary to perform the auto-calibration procedure and enter the real blade width to Setwork

Controller ([See Section 4.2](#)) (EG300 only).

Correct the scale indicator position if necessary (EG300 only).

See Figure 6-9.

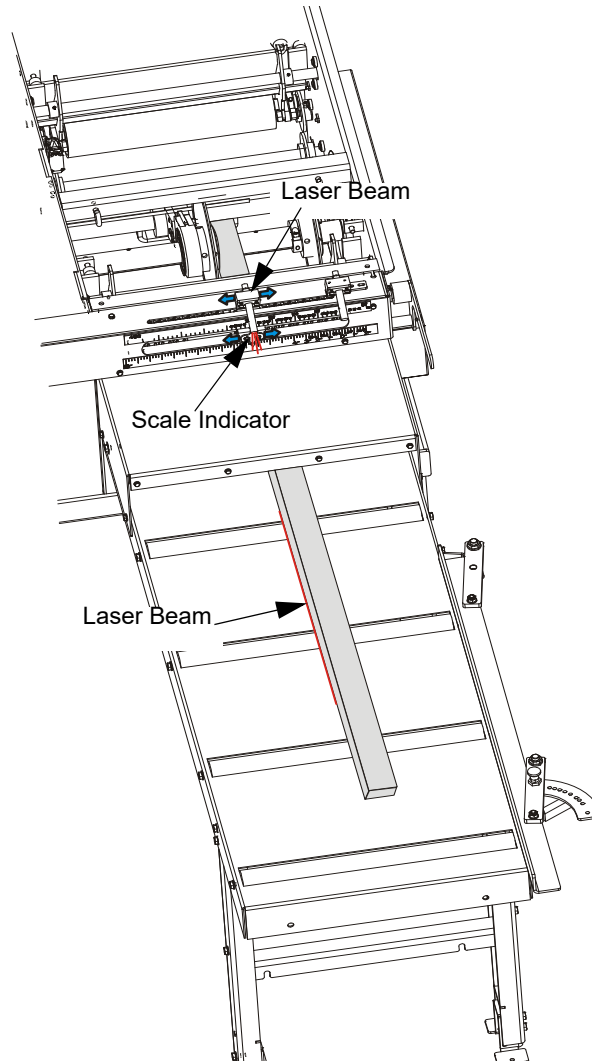

FIG. 6-9

## 6.8 Blade Sharpening

The blade teeth should be sharpened as soon as their dullness, measured as shown in the figure on the right, is .10 -.20 mm (0.0039 - 0.0078").



Use diamond grinding wheels for sharpening the blades. Apply intensive cooling during sharpening to prevent overheating and structural changes in the cemented carbide tips.

**Blades with hard tips (GLOTECH series) must be intensively cooled with water during sharpening. Failure to do so will result in cracks in the tips.**

In Multix type blades the carbide tips should be .4 - .6 mm (0.0157 - 0.0236") wider than the carbides in the wiper slots. (See the figure below.) If this difference is not kept, it will result in disk overheating and – in extreme case – in cracks in the blade gullets. The carbide plates in the wiper slots remove sawdust and splinters from the kerf. They also cause sawdust to be blown away.

When sharpening, maintain the proper tooth geometry as indicated in the figure below.

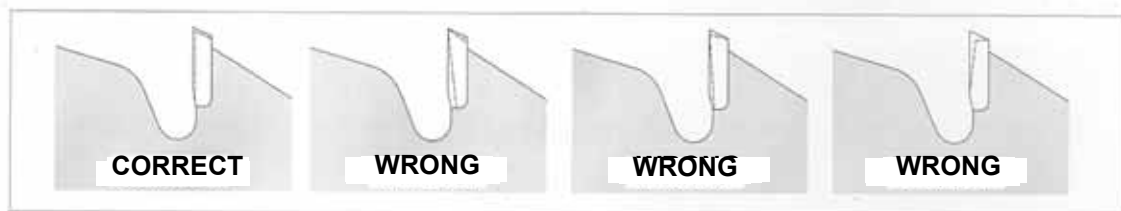

## 6.9 Using the Blades

The surfaces of spacers should be clean and flat against one another. The blade should not rotate on the shaft during sharpening as it will lead to its damage.

### **Do not set teeth with cemented carbide tips!**

Do not make any modifications to the blade teeth!

Do not operate the machine if any of the blades is dull. Using dull blades causes stronger cutting resistance, decreased cut accuracy and may result in blade burning and even cracks in the gullets and the wiper slots.

### **Do not exceed the maximum blade rotation speed recommended for a given type of material!**

When using Multix type blades, keep at least 5 mm (0.197") spacing between the bottom of the wiper slot and the spacer outer diameter.

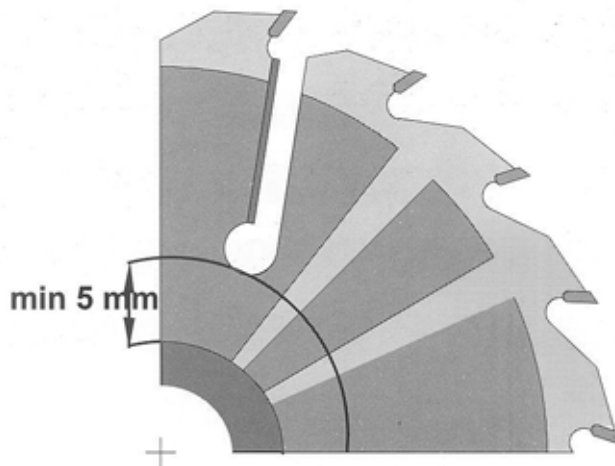

To remove any sawdust buildup from the blade disk, preferably use a solution of hot water and soda or another cleaner.

Any blades which are not used for a longer period of time should be properly maintained.

The blades should be used in accordance with safety rules and their application and with machines in good operating condition and equipped with suitable safety guards.

## 6.10 EG300 Safety Devices Inspection (CE<sup>1</sup> version only)

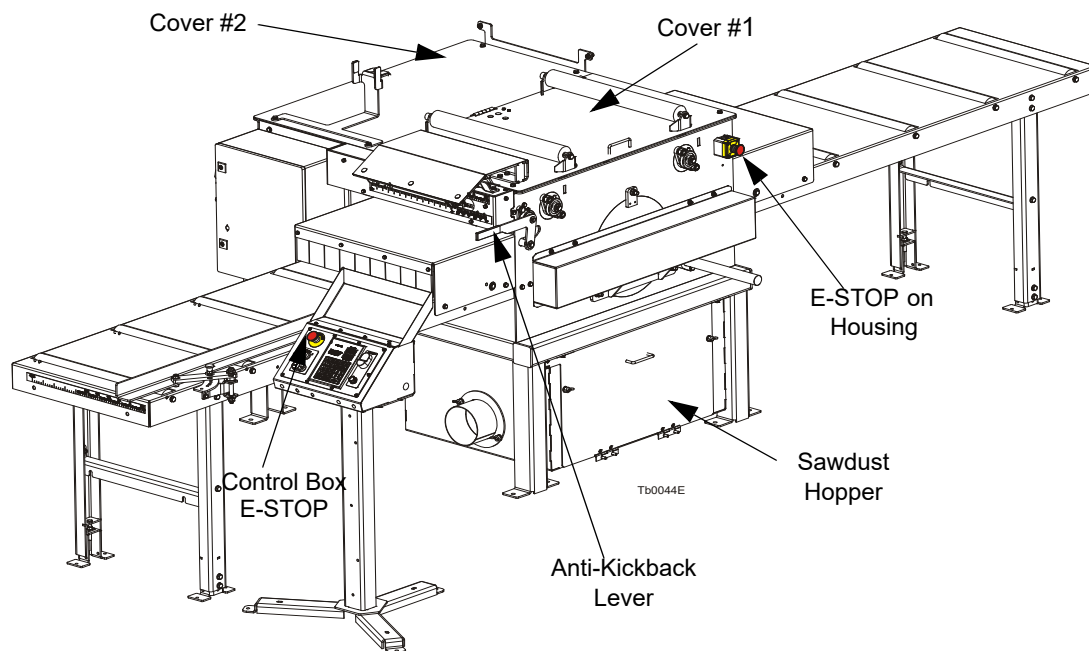

FIG. 6-9

The following safety devices on the EG300 Edger must be inspected before every shift:

- E-STOP button circuit - control box
- E-STOP button circuit - housing weldment
- Safety switch circuit - cover #1
- Safety switch circuit - cover #2
- Safety switch circuit - sawdust hopper
- Blades minimum distance safety switch
- Blades maximum distance safety switch
- Safety switch disabling blades distance setting after starting sawing
- Safety switch circuit - anti-kickback fingers (two persons)
- Motor brake and its circuit

### 1. Control Box E-STOP Button Circuit Inspection

- Start the main motor;

---

1. CE - mandatory conformity marking for products sold in the European Union

- Push the E-STOP button located on the control box. The motor should stop. It should not be possible to restart the motor until the E-STOP is released.

## 2. Housing E-STOP Button Circuit Inspection

- Start the main motor;
- Push the E-STOP button located on the edger housing. The motor should stop. It should not be possible to restart the motor until the E-STOP is released.

## 3. Cover Safety Switch Circuit Inspection - Cover #1

- Start the main motor;
- Open the cover #1;
- The main motor should stop;
- Try to start the motor using the START button. It should not be possible to start the motor.
- Close the cover #1;
- The motor should remain turned off.



**FIG. 6-9**

## 3. Cover Safety Switch Circuit Inspection - Cover #2

- Start the main motor;
- Open the cover #2;
- The main motor should stop;
- Try to start the motor using the START button. It should not be possible to start the motor.
- Close the cover #2;
- The motor should remain turned off.

**FIG. 6-9**

#### **4. Sawdust Hopper Safety Switch Circuit Inspection**

- Start the main motor;
- Open the sawdust hopper cover;
- The main motor should stop;
- Try to start the motor using the START button. It should not be possible to start the motor.
- Close the sawdust hopper cover;
- The motor should remain turned off.

#### **5. Minimum Blades Distance Safety Switch Inspection**

- Press and hold the LEFT arrow on the control box until the blades distance setting is stopped;



- Repeat the above step using the LEFT arrow on the Setworks control panel.

#### **6. Maximum Blades Distance Safety Switch Inspection**

- Press and hold the RIGHT arrow on the control box until the blades distance setting is stopped;
- Repeat the above step using the RIGHT arrow on the Setworks control panel.

#### **7. Inspection of the Safety Switch Disabling Blades Distance Setting After Starting Sawing**

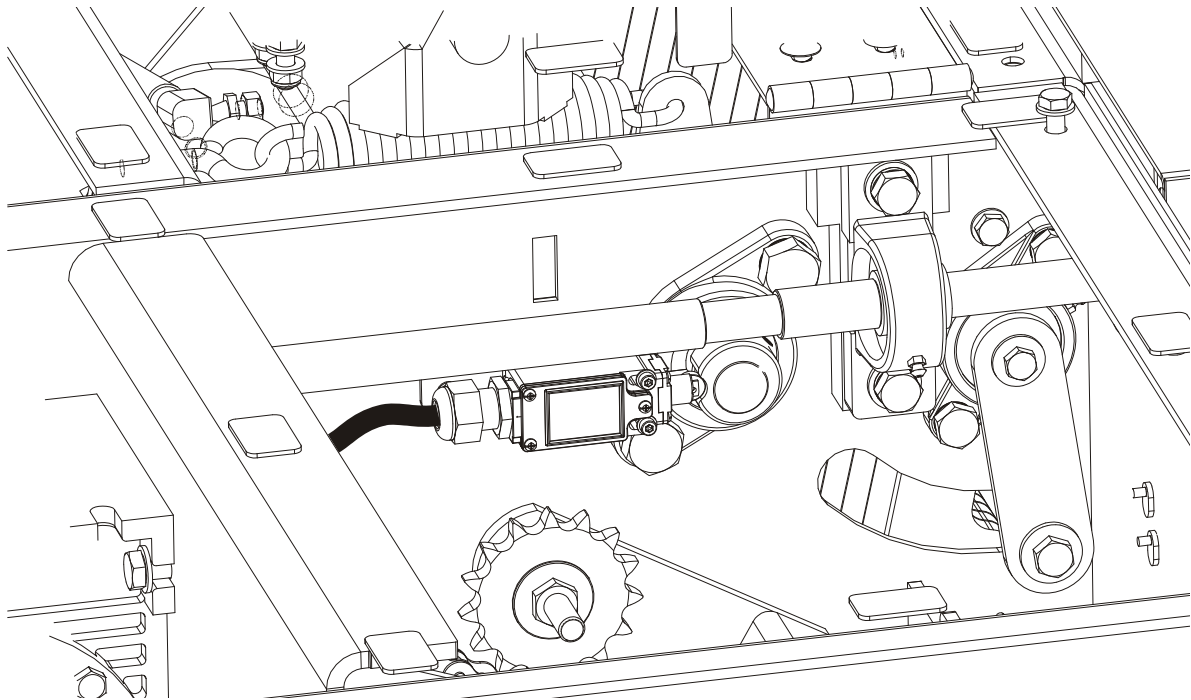

**FIG. 6-9**

- Start the main motor;
- Start the board feed;
- Check if it is possible to move the blade in and out using the appropriate button on the control box and then on the Setworks;

- Push down the lever shown below;

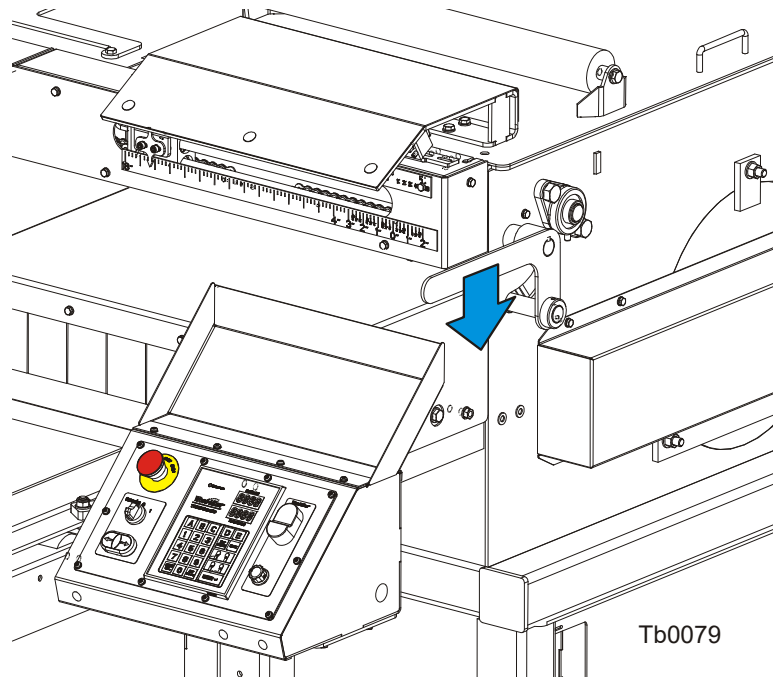
**FIG. 6-9**

- Check again if it is possible to set the blades distance using the appropriate button on the control box and on the Setworks.

8. Safety Switch Circuit Inspection - Anti-kickback Fingers (Two Persons)



FIG. 6-9

- Start the main motor;

# 6

## Maintenance & Alignment

### EG300 Safety Devices Inspection (CE version only)

- Push the anti-kickback lever (shown below) down to raise the anti-kickback fingers;



FIG. 6-9

- The main motor should stop;
- With the anti-kickback fingers raised, try to start the motor using the START button. It should not be possible to start the motor.

- Lower the anti-kickback fingers to their working position.



FIG. 6-9

### 9. Motor Brake and its Circuit Inspection

- Start the motor. Stop the motor by pushing the STOP button. Measure the braking time.
- Start the motor. Stop the motor by turning the key switch to the “0” position. Measure the braking time.
- Start the motor. Stop the motor by turning the key switch to the “H” position. Measure the braking time.
- The motor braking time should be shorter than 10 seconds. If it is longer, adjust or replace the brake linings. See the motor manual.

## 6.11 EG250 Safety Devices Inspection (CE<sup>1</sup> version only)

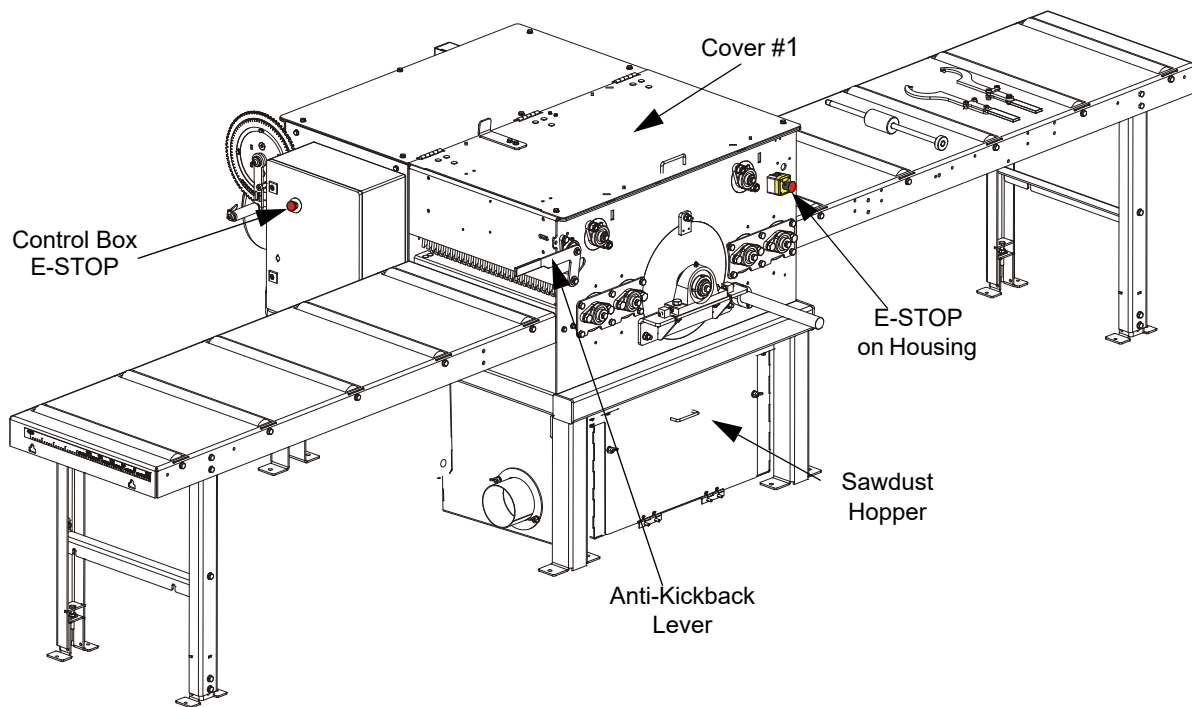

FIG. 6-9

The following safety devices on the EG300 Edger must be inspected before every shift:

- E-STOP button circuit - control box
- E-STOP button circuit - housing weldment
- Safety switch circuit - cover
- Safety switch circuit - sawdust hopper
- Anti-Kickback Safety switch circuit - anti-kickback fingers (two persons)
- Motor brake and its circuit

### 1. Control Box E-STOP Button Circuit Inspection

- Start the main motor;
- Push the E-STOP button located on the control box. The motor should stop. It should not be possible to restart the motor until the E-STOP is released.

### 2. Housing E-STOP Button Circuit Inspection

- Start the main motor;

---

1. CE - mandatory conformity marking for products sold in the European Union



- Push the E-STOP button located on the edger housing. The motor should stop. It should not be possible to restart the motor until the E-STOP is released.

### 3. Cover Safety Switch Circuit Inspection

- Start the main motor;
- Open the cover ;
- The main motor should stop;
- Try to start the motor using the START button. It should not be possible to start the motor.
- Close the cover;
- The motor should remain turned off.



FIG. 6-9

### 4. Sawdust Hopper Safety Switch Circuit Inspection

- Start the main motor;
- Open the sawdust hopper cover;
- The main motor should stop;
- Try to start the motor using the START button. It should not be possible to start the motor.

- Close the sawdust hopper cover;
- The motor should remain turned off.



8. Safety Switch Circuit Inspection - Anti-kickback Fingers (Two Persons)



FIG. 6-9

- Start the main motor;

# 6

## Maintenance & Alignment

### EG250 Safety Devices Inspection (CE version only)

---

- Push the anti-kickback lever (shown below) down to raise the anti-kickback fingers;



**FIG. 6-9**

- The main motor should stop;
- With the anti-kickback fingers raised, try to start the motor using the START button. It should not be possible to start the motor.

- Lower the anti-kickback fingers to their working position.



FIG. 6-9

### 9. Motor Brake and its Circuit Inspection

- Start the motor. Stop the motor by pushing the STOP button. Measure the braking time.
- Start the motor. Stop the motor by turning the key switch to the “0” position. Measure the braking time.
- Start the motor. Stop the motor by turning the key switch to the “H” position. Measure the braking time.
- The motor braking time should be shorter than 10 seconds. If it is longer, adjust or replace the brake linings. See the motor manual.

## SECTION 7 SPECIFICATIONS

### 7.1 Overall Dimensions

See Figure 7-1. The major dimensions of the EG300 Edger are shown below (dimensions are in millimeters and inches).

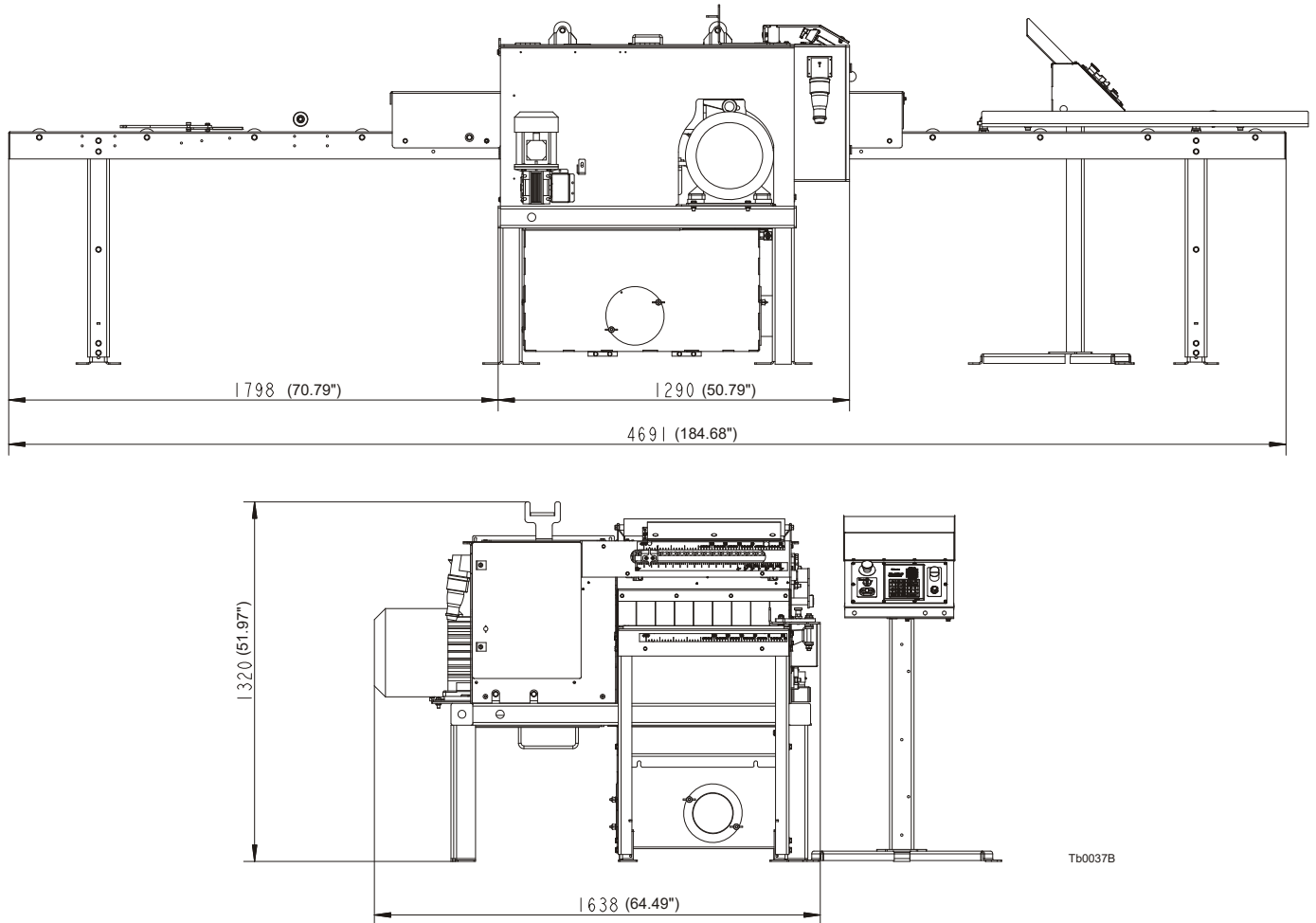

**FIG. 7-2**

See Table 7-1 The overall dimensions of the Edger are listed in the table below.

<b>Weight</b>	988 kg (2178 lb)
<b>Height</b>	1320 mm (51.97")
<b>Width</b>	1638 mm (64.49")
<b>Length</b>	4691 mm (184.68")

**TABLE 7-1**

See Figure 7-3. The major dimensions of the EG250 Edger are shown below (dimensions are in millimeters and inches).

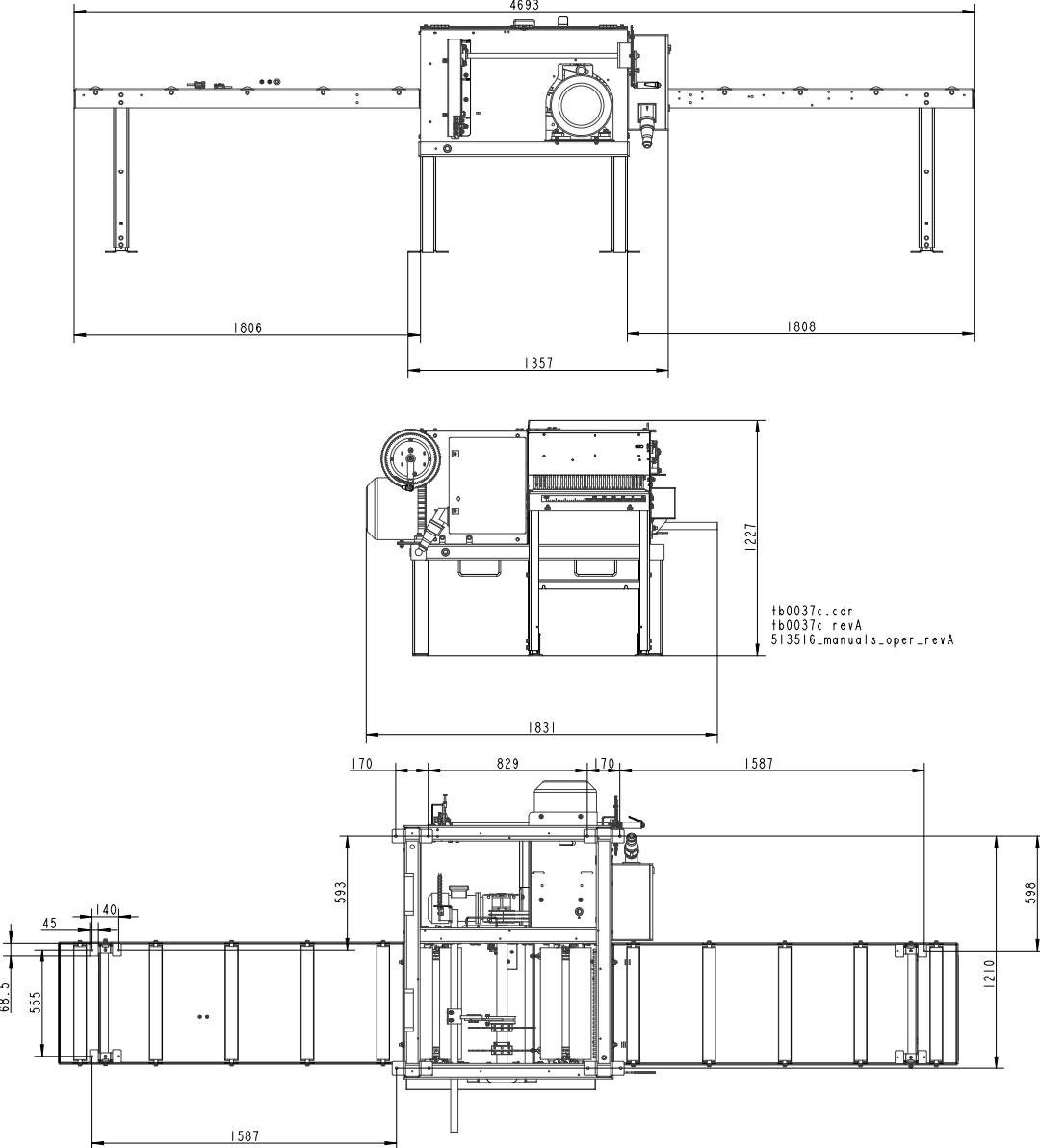

**FIG. 7-4**

## 7.2 Multirip Edger Specifications

See Table 7-2 The power option specifications of the Wood-Mizer Edger is listed below.

	Motor Specifications (CE and U.S.)	Motor Specifications (CE and U.S.)	Motor Specifications
<b>Motor Type</b>	<b>E20</b> Electric Motor	<b>E25</b> Electric Motor	<b>E25</b> Electric Motor
<b>Manufacturer</b>	Tamel SA, Poland	Tamel SA, Poland	Tamel SA, Poland
<b>Voltage</b>	400V, 460V	400V, 460V	230V
<b>Maximum Current</b>	26.5 A	33,5	56,5
<b>RPM</b>	2940 RPM@50Hz 3520 RPM@60Hz	2940 RPM@50Hz 3520 RPM@60Hz	2940 RPM@50Hz
<b>Rated Power</b>	15kW ( 20HP )@50Hz 17,3kW ( 23,5HP )@60Hz	18.5kW ( 25HP )@50Hz 21,3kW ( 29HP )@60Hz	18.5kW ( 25HP )@50Hz
<b>Manufacturer Part #</b>	3Sg 160M-2B-HM-T	3Sg 160L-2-HM-T	3Sg 160L-2-HM-T

**TABLE 7-2**

See Table 7-3 The noise level of the Edger is given below.<sup>1 23</sup>

	Engaged
<b>Edger Equipped With E20 Electric Motor</b>	84 dB (A)

**TABLE 7-3**

1. The noise level measurement was taken in accordance with PN-EN ISO 3746 Standard. Value for associated uncertainty  $K=4\text{dB}$ .
2. The measured values refer to emission levels, not necessarily to noise levels in the workplace. Although there is a relation between emission levels and exposure levels, it is not possible to determine with certainty if preventives are needed or are not needed. The factors affecting a current level of noise exposure during work are inter alia room characteristics and characteristics of other noise sources, e.g. number of machines and machining operations nearby. Also, the permissible exposure level value may vary depending on country. This information enables the machine's user to better identify hazards and a risk.
3. **IMPORTANT!** The total value of hand-arm vibration the operator may be exposed to does not exceed  $2.5 \text{ m/s}^2$ . The highest root mean square value of weighted acceleration to which the whole operator's body is subjected does not exceed  $0.5 \text{ m/s}^2$ .

**See Table 7-4** Other specifications of the Edger are listed below.

<b>Number of Blades</b>	2 - 5
<b>Blade Diameter</b>	350 mm (13.78")
<b>Blade Speed</b>	2940 RPM@50Hz 3520 RPM@60Hz
<b>Feed Speed</b>	0 - 25m(82 ft)/min
<b>Minimum Board Length</b>	700 mm (27.56")
<b>Minimum Board Thickness</b>	10 mm (0.394")
<b>Maximum Board Thickness</b>	60 mm (2.362")
<b>Maximum Egding Width</b>	420 mm (16.535")
<b>Maximum Material Width</b>	550 mm (21.65")

**TABLE 7-4**

### 7.3 Dust Extractor Specifications

See Table 7-5 Specifications of the dust extractors used on the Edger are listed below.<sup>1</sup>

<b>Airflow</b>	1200 m <sup>3</sup> /h 3937 ft <sup>3</sup> /h
<b>Inlet diameter</b>	150 mm (5.905")
<b>Motor power</b>	1,5 kW
<b>Number of sacks</b>	2 pcs
<b>Sack capacity</b>	0.25 m <sup>3</sup> 0.82 ft <sup>3</sup>
<b>Weight</b>	110 kg (242.5 lb)
<b>Pressure drop</b>	1,5kPa (0.22 psi) <sup>1</sup>
<b>Recommended conveying air velocity in the duct</b>	20 m/s 65.6 ft/s

**TABLE 7-5**

<sup>1</sup> The pressure drop between the inlet of the capture device and the connection to the CADES should be maximum 1,5 kPa (for the nominal air flow rate). If the pressure drop exceeds 1,5 kPa the machine might not be compatible with conventional CADES.



**IMPORTANT!** The dust extractor hoses must be grounded or made with materials not accumulating electrostatic charge.



**CAUTION!** Always turn on the dust extractor before starting the machine.

---

1. External chip and dust extraction equipment with fixed installations are dealt with in EN 12779:2016-04.



## SECTION 8 REPLACEMENT PARTS

### 8.1 How To Use The Parts List

- Go to the appropriate section and locate the part in the illustration.
- Use the number pointing to the part to locate the correct part number and description in the table.
- Parts shown indented under another part are included with that part.
- Parts marked with a diamond (◆) are only available in the assembly listed above the part.

See the sample table below. Sample Part #A01111 includes part F02222-2 and subassembly A03333. Subassembly A03333 includes part S04444-4 and subassembly K05555. The diamond (◆) indicates that S04444-4 is not available except in subassembly A03333. Subassembly K05555 includes parts M06666 and F07777-77. The diamond (◆) indicates M06666 is not available except in subassembly K05555.

8.1 Sample Assembly				
REF.	SAMPLE ASSEMBLY, COMPLETE (Includes All Indented Parts Below)	PART #	QTY	
	Sample Part	A01111	1	
1	Sample Subassembly (Includes All Indented Parts Below)	F02222-22	1	
2	Sample Part (Indicates Part Is Only Available With A03333)	A03333	1	
	Sample Subassembly (Includes All Indented Parts Below)	S04444-4	1	◆
3	Sample Part (Indicates Part Is Only Available With K05555)	K05555	1	
	Sample Part	M06666	2	◆
4	SAMPLE ASSEMBLY, COMPLETE (Includes All Indented Parts Below)	F07777-77	1	

#### To Order Parts:

From Europe call your local distributor or our European Headquarters and Manufacturing Facility in Koło, Nagórna 114 St, Poland at **+48-63-2626000**. From the continental U.S., call our U.S. Headquarter 8180 West 10th St. Indianapolis, IN 46214, toll-free at **1-800-525-8100**. Have your customer number, VIN, and part numbers ready when you call. From other international locations, contact the Wood-Mizer distributor in your area for parts.

#### Office Hours:

Country	Monday - Friday	Saturday	Sunday
Poland	7 a.m.- 3 p.m.	Closed	Closed
US	8 a.m.- 5 p.m.	8 a.m.- 5 p.m	Closed



**CAUTION!** It is strongly recommended that only original spare parts be used.

## 8.2 Main Shaft Assembly

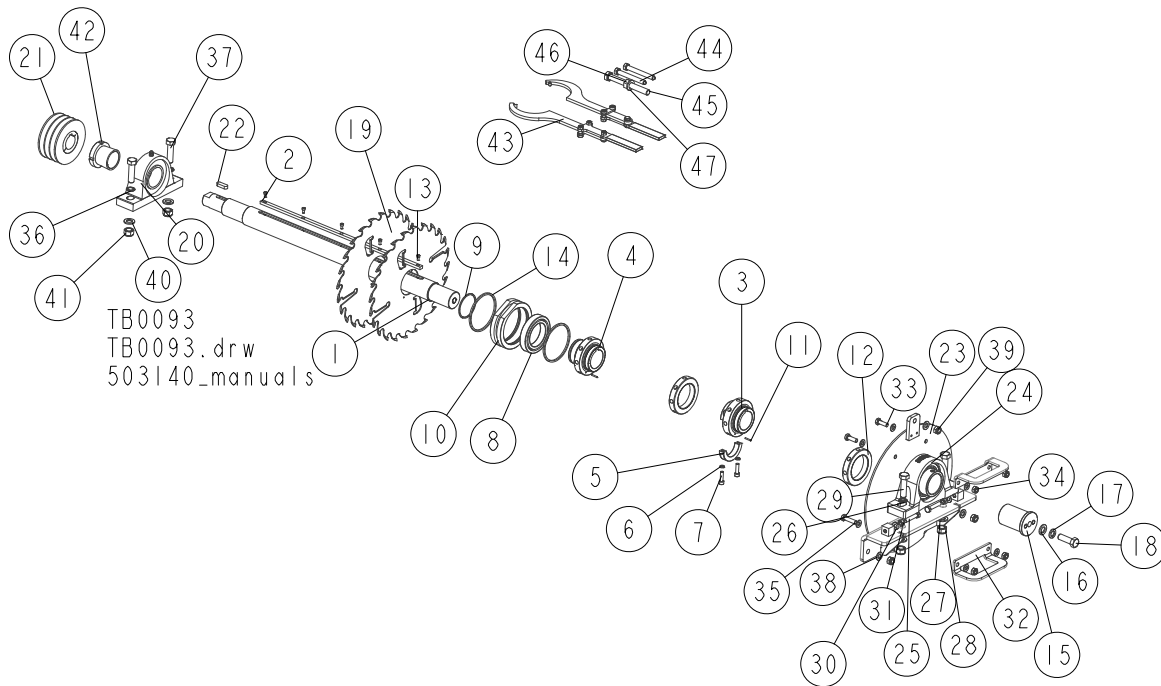

REF.	DESCRIPTION (* Indicates Parts Available In Assemblies Only)	PART #	QTY
	SHAFT, EG300 MAIN - COMPLETE	503887	1
	SHAFT, EDGER BLADE DRIVE - COMPLETE	514131	1
1	SHAFT, CIRCULAR BLADE CHROMIUM - PLATED	514130-1	1
2	KEY, 12X8X585 SPECIAL CHROMIUM - PLATED	514139-1	1
3	ARBOR, ZINC-PLATED MOUNTING	514136-1	1
4	ARBOR, EDGER BLADE (2) ZINC-PLATED	514137-1	1
5	WRAP, ZINC-PLATED	514135-1	1
6	WASHER 8,2 SPLIT LOCK ZINC	F81054-4	2
7	SCREW, M8 X 30-8.8 HEX SOCKET HEAD CAP ZINC	F81002-31	2
8	BEARING, 6014 2RS	089164	1
9	RING, 70MM OUTSIDE RETAINING	089165	1
10	BUSHING, BLADE SLIDE PLATE	514271-1	1
11	PIN, 3M6 X 20 ROLL	F81048-2	2
12	NUT, CLAMPING	089092-1	2
13	SCREW, M5X10 DIN912 A2-70 HEX SOCKET HEAD CAP STAINLESS STEEL	F81000-23	5
14	RING, 110MM INSIDE RETAINING	089166	2
15	SLEEVE, ADAPTER	516879	1
16	WASHER, 17 FLAT ZINC	F81058-1	1
17	WASHER, 16.3 SPLIT LOCK ZINC	F81058-2	1
18	BOLT, M16 X 50-8.8 HEX HEAD	F81006-7	1
19	BLADE DNPDE MULTIX 350 3,9/2,6 SILVER	089144-2	2
20	BEARING, NSK UKP211D1+H2311X	101109	1
21	PULLEY, PBT SPB 125/42(F02321+T31111)	503149	1
22	KEY, A12X8X36, PARALLEL	503182	1
	COVER, SIDE W/BEARING - COMPLETE	503143	1
23	COVER, SIDE W/BEARING SUPPORT BRACKET PTD	503888-1	1
24	BEARING SYJ60TF (UCP 212)	516904	1

# REPLACEMENT PARTS

## Main Shaft Assembly

8

REF.	DESCRIPTION (* Indicates Parts Available In Assemblies Only)	PART #	QTY
25	BOLT, M10x50-8.8-HEX HEAD FULL THREAD ZINC	F81003-4	2
26	WASHER, BN 791 M16/17 BOS. RIBBED LOCK	F81056-13	2
27	WASHER, 17 FLAT ZINC	F81058-1	2
28	NUT, M16,HEX, NYLON ZINC LOCK	F81036-2	2
29	BOLT, M16 X 60 8.8 HEX HEAD FULL THREAD ZINC	F81006-12	2
30	WASHER, 10.5 FLAT ZINC	F81055-1	10
31	NUT, M10-8-B-HEX ZINC	F81033-3	2
32	BRACKET, EG300 SIDE COVER	514845-1	2
33	BOLT, M10X30-5.8 HEX HEAD FULL THREAD ZINC	F81003-2	2
34	NUT, M10-8-B HEX NYLON ZINC LOCK	F81033-1	4
35	BOLT, M10 X 40-8.8 HEX HEAD FULL THREAD ZINC	F81003-16	2
36	WASHER, BN 791 M16/17 BOS. RIBBED LOCK	F81056-13	2
37	BOLT, M16 X 60 8.8 HEX HEAD FULL THREAD ZINC	F81006-12	2
38	WASHER, 13 FLAT ZINC	F81056-1	3
39	NUT, M12-8 HEX NYLON ZINC LOCK	F81034-2	3
40	WASHER, 17 FLAT ZINC	F81058-1	2
41	NUT, M16, HEX NYLON ZINC LOCK	F81036-2	2
42	SLEEVE, H2311H ADAPTER	503075	1
43	WRENCH, 628500/110/115 HOOK	504355	2
	KIT, SLEEVE MOUNTING/DISMOUNTING	514986	1
44	BOLT, SLEEW /DISMOUNTING	514992-1	1
45	BOLT M16X140 -8.8-FE/ZN5	F81006-48	1
46	NUT, M16, HEXAGON, GRADE 5.8 PLAIN	F81036-1	1
47	WASHER, 17 FLAT ZINC	F81058-1	1

## 8.3 Spacer Mounting Kit (Optional)

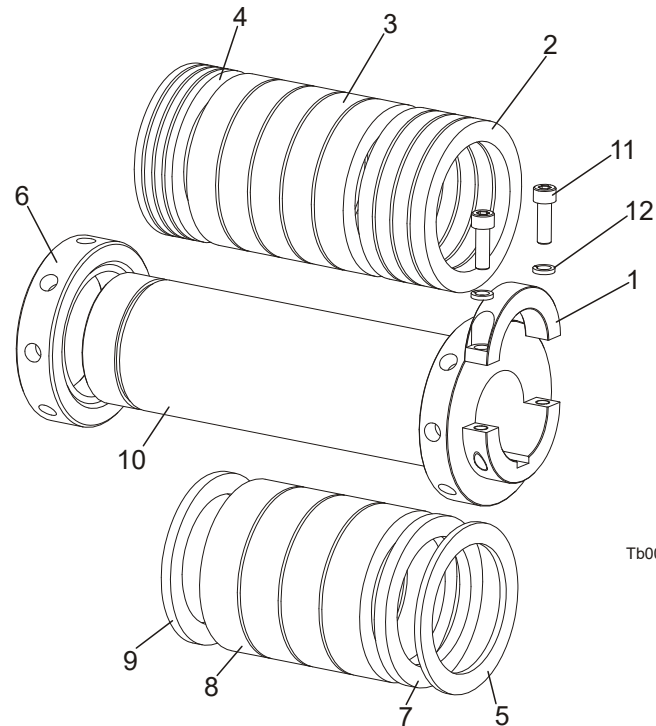

Tb0069B

REF.	DESCRIPTION (◆ Indicates Parts Available In Assemblies Only)	PART #	QTY
	<b>MOUNTING KIT FOR 5 BLADES W/LONG BUSHING</b>	514151 <sup>1</sup>	1
1	COLLAR, LOCKING (EDGER)	514135-1	1
2	RING, SPACER	090967-1	4
3	SPACER	090968-1	5
4	SPACER, G=5 THICK	090971-1	4
5	SPACER, G=4.2MM THICK	091135-1	1
6	NUT, LOCKING ZINC-PLATED	091493-1	1
7	SPACER, G=7MM THICK	091509-1	1
8	SPACER, G=26.1MM THICK	091510-1	4
9	SPACER, G=6.4MM THICK	091511-1	1
10	BUSHING, BLADE MOUNT - LONG	514152-1	1
11	BOLT, M8x25-8.8 SOCKET HEAD	F81002-21	2
12	WASHER, 8,2 SPLIT LOCK ZINC	F81054-4	2

<sup>1</sup> It is possible to mount at most 3 blades as optional equipment.

**8.4 Infeed Rollers Assembly**

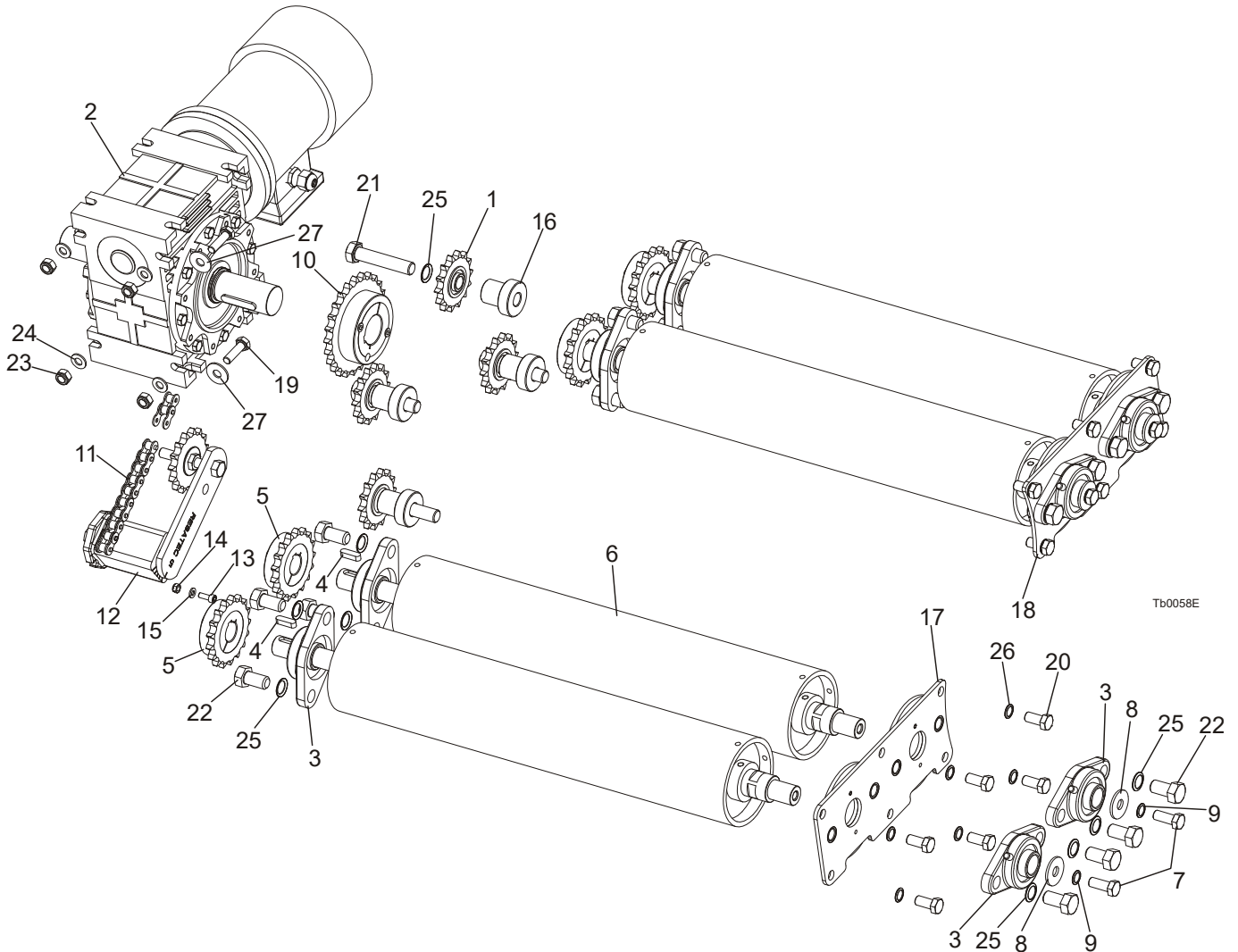

Tb0058E

REF.	DESCRIPTION (◆ Indicates Parts Available In Assemblies Only)	PART #	QTY
	<b>INFEEED ROLLER DRIVE ASSEMBLY, COMPLETE</b>	503145	1
1	SPROCKET, Z14 5/8"x3/8" W/BEARING	088867	4
2	MOTOREDUCER, MR-80/64/1.1-1400/K3/V6	098663	1
	<b>ROLLER, INFEEED COMPLETE</b>	503144	4
3	BEARING, UCFL 205 CX W/HOUSING	089124	2
4	KEY, PARALLEL A 8x7x28 PN-70/M-85005	096035	1
5	SPROCKET, 17Z 10B/25 (T43995+T31074) ZINC	503146	1
6	ROLLER, INFEEED PTD	503176-1	1
7	BOLT, M12x30-8.8-HEX HEAD FULL THREAD ZINC	F81004-22	1
8	WASHER, 13 SPECIAL FLAT ZINC	F81056-14	1
9	WASHER, 792 M12/13 (Bossard) RIBBED LOCK	F81056-15	1
10	SPROCKET, 25Z 10B/38 (T43999+T31109) ZINC	503147	1
11	CHAIN, INFEEED ROLLERS DRIVE - COMPLETE	503179	1
	CHAIN, 10B-1-141	503180	1
	LINK, 10B-1Pz MASTER	088671	2
	TENSIONER, TEKS 5, CHAIN COMPLETE	503884	1

## 8

**REPLACEMENT PARTS***Infeed Rollers Assembly*

12	TENSIONER, TEKS5 5/8x3/8-12S (T31678+T29422). CHAIN	503883	1	
13	BOLT, M6x16 -8.8- SOCKET HEAD ZINC	F81001-21	1	
14	NUT, M6-8-B-HEX NYLON ZINC LOCK	F81031-2	1	
15	WASHER, 6,4 FLAT ZINC	F81053-1	1	
16	BUSHING, 45x16.5x45, SPACER ZINC	503893-1	4	
17	PLATE, INFEED ROLLER MOUNTING LEFT	505473-1	1	
18	PLATE, INFEED ROLLER MOUNTING RIGHT	505475-1	1	
19	BOLT, M10x35-8.8 HEX HEAD FULL THREAD ZINC	F81003-17	4	
20	BOLT, M12x25-8.8-HEX HEAD FULL THREAD ZINC	F81004-31	12	
21	BOLT, M16x80 8.8-B- HEX HEAD FULL THREAD ZINC	F81006-11	4	
22	BOLT, M16X30 8.8 HEX HEAD FULL THREAD ZINC	F81006-36	17	
23	NUT, M10-8-B -HEX NYLON ZINC LOCK	F81033-1	4	
24	WASHER, 10,5 FLAT ZINC	F81055-1	4	
25	WASHER, BN 791 M16/17 Bossard RIBBED LOCK	F81056-13	20	
26	WASHER, 792 M12/13 (Bossard) RIBBED LOCK	F81056-15	12	
27	WASHER, 10.5 SPECIAL FLAT ZINC	F81055-6	4	

**8.5 Hold-Down Roller & Anti-Kickback Assembly (EG300)**

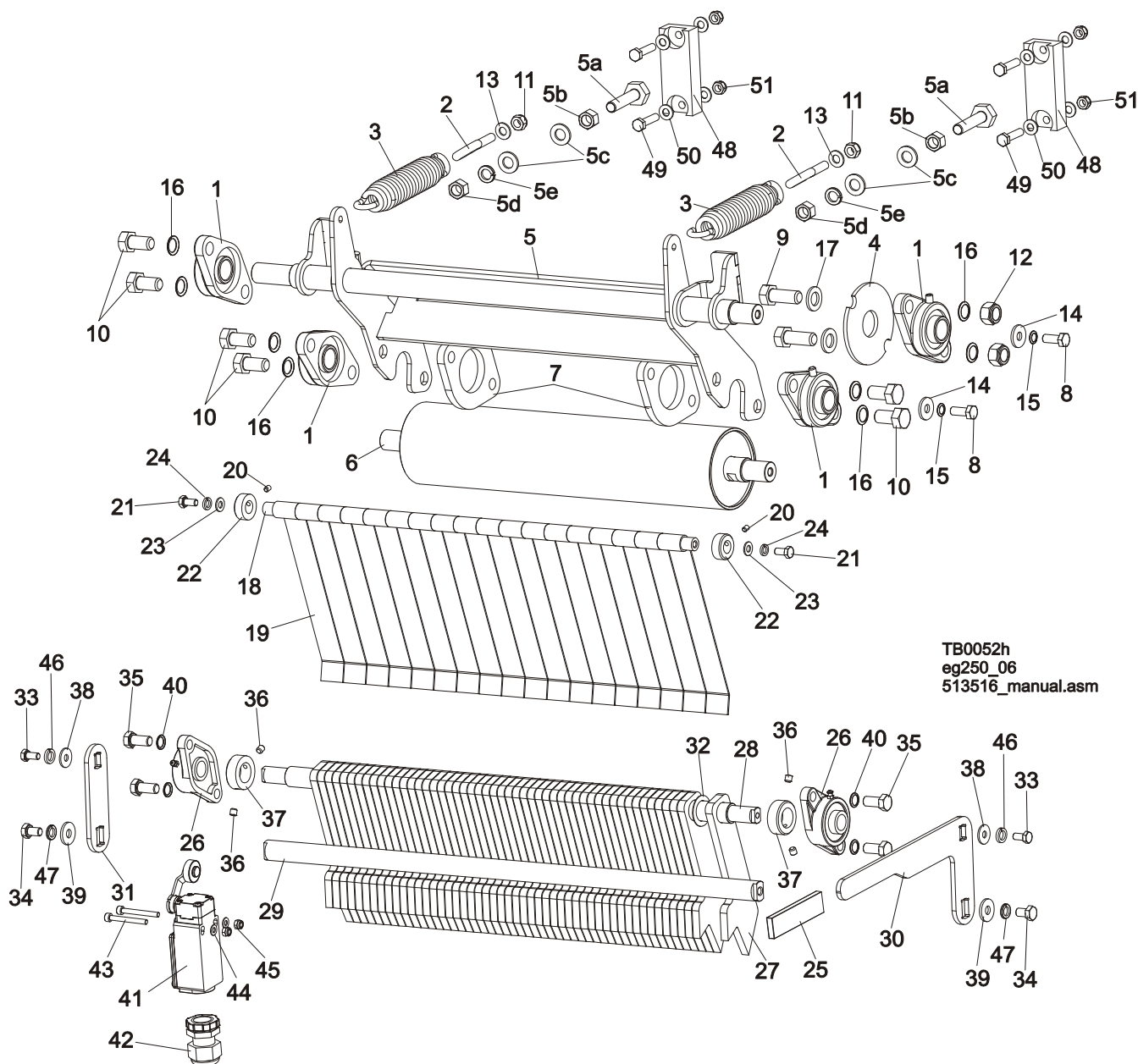

REF.	DESCRIPTION (◆ Indicates Parts Available In Assemblies Only )	PART #	QTY
	<b>HOLD-DOWN ROLLER, COMPLETE</b>	503150	1
	<b>ROLLER, REAR HOLD-DOWN COMPLETE (2)</b>	507536	1
1	BEARING, UCFL 205 CX W/HOUSING	089124	4
2	TENSIONER, ZINC-PLATED	089153-1	2
3	SPRING, HOLD-DOWN ROLLER - ZINC-PLATED	089689-1	2
4	DISK, DRIVE RUNNER MOUNTING, PTD	502190-1	1
5	BRACKET, HOLD-DOWN ROLLER PTD	503151-1	1
	BRACKET, REAR HOLD-DOWN ROLLER MOUNT (2) PTD	507534-1	1
5a	BOLT, SPECIAL M12X55 EDGER ZINC	515410-1	2
5b	NUT, M12, HEXAGON, GRADE 5.8, ZINC	F81034-1	4
5c	WASHER, M12, FLAT, ZINC	F81056-1	4

**REPLACEMENT PARTS***Hold-Down Roller & Anti-Kickback Assembly (EG300)*

5d	NUT, M12, HEXAGON, GRADE 5.8, ZINC	F81034-1	4	
5e	WASHER, M12 SPLIT LOCK ZINC	F81056-2	2	
6	ROLLER, PTD HOLD-DOWN	503170-1	1	
7	PLATE, BEARING HOUSING MOUNTING	505491-1	2	
8	BOLT, M10x25-8.8-HEX HEAD FULL THREAD ZINC	F81003-11	2	
9	BOLT, M16x40-8.8 HEX HEAD FULL THREAD ZINC	F81006-13	2	
10	BOLT, M16X30 8.8 HEX HEAD FULL THREAD ZINC	F81006-36	6	
11	NUT, M10-8-B HEX NYLON ZINC LOCK	F81033-1	2	
12	NUT, M16-8 HEX NYLON ZINC LOCK	F81036-2	2	
13	WASHER, 10.5 FLAT ZINC	F81055-1	2	
14	WASHER, 10.5 SPECIAL FLAT ZINC	F81055-6	2	
15	WASHER, 791 M10/10.5 RIBBED LOCK	F81055-7	2	
16	WASHER, BN 791 M16/17 Bos. RIBBED LOCK	F81056-13	8	
17	WASHER, 17 FLAT ZINC	F81058-1	2	
	<b>SAWDUST SHIELD ASSEMBLY</b>	503163	1	
18	SHAFT, SAWDUST SHIELD ZINC-PLATED	089236-1	1	
19	PLATE, SAWDUST SHIELD ZINC-PLATED	503153-1	18	
20	SCREW, M6X10-45H HEX SOCKET SET W/FLAT POINT ZINC	F81001-26	2	
21	BOLT, M8x20 -5.8-B HEX HEAD FULL THREAD ZINC	F81002-1	2	
22	RING, 17 Fe/Zn5 STOPPING LIGHT TYPE	F81039-1	2	
23	WASHER, 8.4 FLAT ZINC	F81054-1	2	
24	WASHER, 8.2 SPLIT LOCK ZINC	F81054-4	2	
	<b>ANTI-KICKBACK ASSEMBLY, COMPLETE</b>	503158	1	
25	CAP, RRWA-91626-110 HANDLE END	086875	1	
26	BEARING, UCFL 204 CX	500060	2	
27	FINGER, ANTI-KICKBACK PTD	503154-1	51	
28	SHAFT, ANTI-KICKBACK FINGER	503159-1	1	
29	ROD, ANTI-KICKBACK FINGER SUPPORT ZINC-PLATED	503160-1	1	
30	HANDLE, ANTI-KICKBACK FINGER LIFT	503161-1	1	
31	PLATE, ANTI-KICKBACK LINK	503162-1	1	
32	WASHER, ZINC-PLATED SPACER	503164-1	50	
33	BOLT, M8x16 -8.8-B HEX HEAD FULL THREAD ZINC	F81002-20	2	
34	BOLT, M10x16-8.8 HEX HEAD FULL THREAD ZINC	F81003-13	2	
35	BOLT, M12x25-8.8 HEX HEAD FULL THREAD ZINC	F81004-31	4	
36	SCREW, M8x8 45H GEOMET HEX SOCKET SET W/FLAT POINT ZINC	F81014-1	4	
37	RING, 25 ZINC STOPPING LIGHT TYPE	F81039-4	2	
38	WASHER, 8.5 FLAT SPECIAL ZINC	F81054-11	2	
39	WASHER, 10.5 FLAT SPECIAL ZINC	F81055-6	2	
40	WASHER, 792 M12/13 (Bossard) RIBBED LOCK	F81056-15	4	
41	SWITCH, GLCB01A1B LIMIT	100931	1	
42	GLAND, SKINTOP PG 13.5 CABLE	086524	1	
43	SCREW, M4x35-8.8 HEX SOCKET HEAD CAP ZINC	F81011-34	2	
44	WASHER, 4.3 FLAT ZINC	F81051-2	2	
45	NUT, M4-B HEX NYLON ZINC LOCK	F81029-1	2	
46	WASHER, 8.2 SPLIT LOCK ZINC	F81054-4	2	
47	WASHER, 10.2 SPLIT LOCK ZINC	F81055-2	2	
48	BUMPER, RUBBER, NARROW	515070	4	
49	BOLT, 8MM X 1.25X35MM HH ZINC	F81002-13	8	
50	WASHER, 8.4 FLAT, ZINC	F81054-1	16	



# REPLACEMENT PARTS

## *Hold-Down Roller & Anti-Kickback Assembly (EG300)*

8

51	NUT,M8-8-B,HEX,NYLON LOCK ZINC	F81032-2	8	
----	--------------------------------	----------	---	--

## 8.6 Anti-Kickback Fingers (EG250)

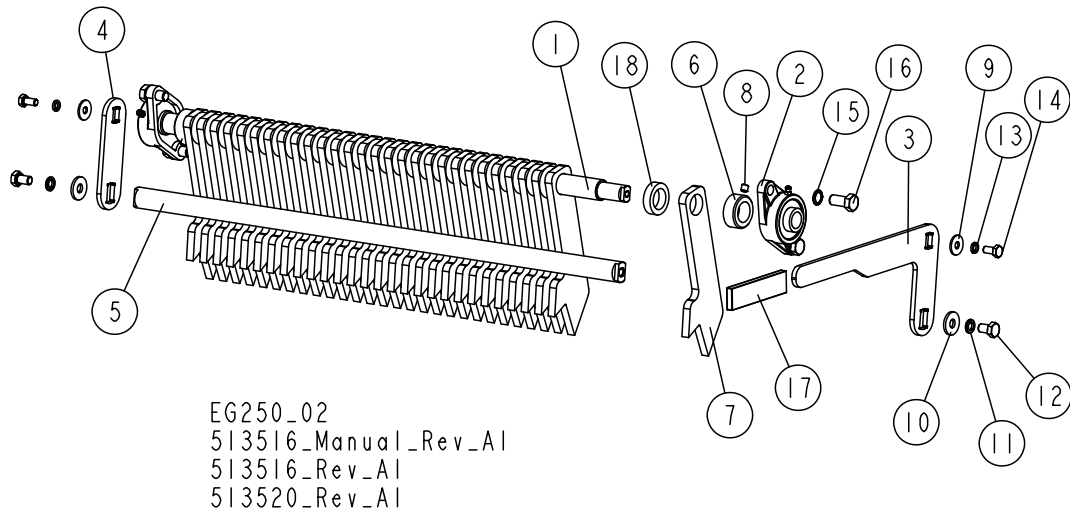

REF.	DESCRIPTION (◆ Indicates Parts Available In Assemblies Only )	PART #	QTY
	<b>ANTIKICKBACK ASSEMBLY</b>	<b>513520</b>	<b>1</b>
1	SHAFT, ANTI-KICKBACK FINGER ZINC-PLATED	503159-1	1
2	BEARING, UCFL 204 (CX).	500060	2
3	HANDLE, ANTI-KICKBACK FINGER LIFT	503161-1	1
4	PLATE, ANTI-KICKBACK LINK	503162-1	1
5	ROD, ANTI-KICKBACK FINGER SUPPORT ZINC-PL.	503160-1	1
6	RING, 25 ZINC-PL. STOPPING LIGHT TYPE	F81039-4	2
7	FINGER, ANTI-KICKBACK	503154-1	29
8	SCREW, M8x8 45H GEOMET HEX SOCKET SET W/FLAT POINT ZINC	F81014-1	2
9	WASHER, ISO 7093-1-8-200 HV-A2E.	F81054-11	2
10	WASHER, 10.5 SPECIAL FLAT ZINC	F81055-6	2
11	WASHER, Z 10.2 SPLIT LOCK ZINC	F81055-2	2
12	BOLT, M10X16-8.8 HEX HEAD FULL THREAD ZINC	F81003-13	2
13	WASHER, 8.2 SPLIT LOCK ZINC	F81054-4	2
14	BOLT, M8X16-8.8-B HEX HEAD FULL THREAD ZINC	F81002-20	2
15	WASHER, 792 M12/13 (Bossard) RIBBED LOCK	F81056-15	4
16	BOLT, M12X25-8.8 HEX HEAD FULL THREAD ZINC	F81004-31	4
17	CAP, RRWA 91626 HANDLE END	086875	1
18	BUSHING, 25.5/38.5-10	513521-1	28

**8.7 Blade Setting Assembly**

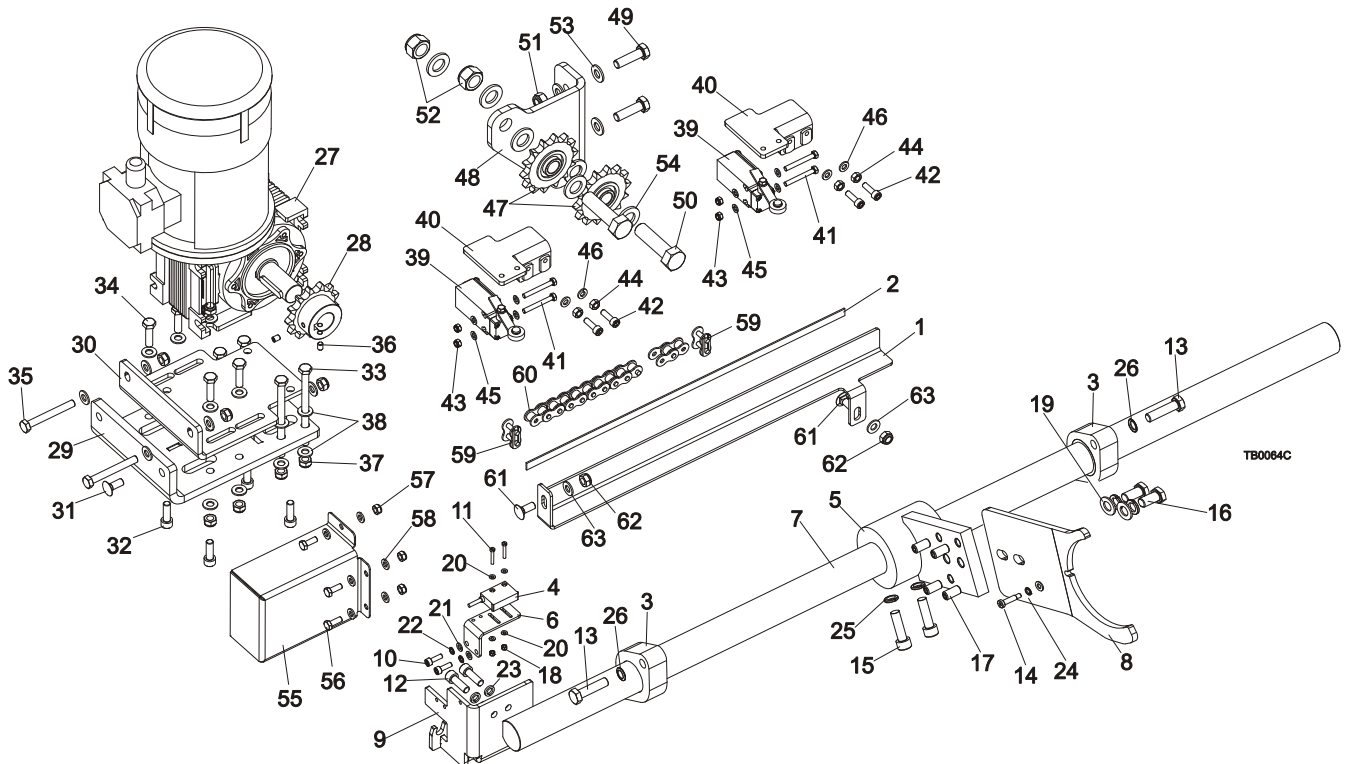

REF.	DESCRIPTION (◆ Indicates Parts Available In Assemblies Only )	PART #	QTY
	<b>BLADE AND LASER SETTING DRIVE ASSEMBLY, COMPLETE</b>	503903	1
1	BRACKET, MAGNETIC STRIP	101025-1	1
2	STRIP, l=450mm MAGNETIC	101410-1	1
	<b>MOVING BLADE SLIDE SHAFT, COMPLETE</b>	503902	1
3	BEARING, COMPLETE	089134	2
4	SENSOR, MSK-320	096014	1
5	BRACKET, BLADE SLIDE	101009-1	1
6	BRACKET, SENSOR MOUNT	101399-1	1
7	SHAFT, BLADE SLIDE BLOCK	101417-1	1
8	PLATE, BLADE SLIDE ZINC-PLATED	500549-1	1
9	BRACKET, BLADE SLIDE CHAIN HOLDER	503911-1	1
10	BOLT, M5x16-8.8-SOCKET HEAD ZINC	F81000-25	2
11	SCREW, M3x20-5.8-A-PAN HEAD ZINC	F81000-8	2
12	BOLT, M8x25 -8.8- SOCKET HEAD ZINC	F81002-21	2
13	BOLT, M10x40-8.8 HEX HEAD FULL THREAD ZINC	F81003-16	4
14	BOLT, M10x50-8.8-HEX HEAD FULL THREAD ZINC	F81003-4	1
15	BOLT, M10x35 SOCKET HEAD ZINC	F81003-56	2
16	BOLT, M12x30-8.8-HEX HEAD FULL THREAD ZINC	F81004-22	2
17	SCREW, M10x1x20 DIN913 STAINLESS STEEL	F81015-1	4
18	NUT, M3-6-HEX NYLON ZINC LOCK	F81028-2	2
19	WASHER, Z12,2 SPLIT LOCK ZINC	F81056-2	2
20	WASHER, 3,2 FLAT ZINC	F81050-2	4
21	WASHER, 5,3 FLAT ZINC	F81052-1	2
22	WASHER, 5,1 SPLIT LOCK ZINC	F81052-2	2

23	WASHER, 8,2 SPLIT LOCK ZINC	F81054-4	2	
24	WASHER, M12 FLAT ZINC	F81056-1	2	
25	WASHER, 10,2 SPLIT LOCK ZINC	F81055-2	2	
26	WASHER, 791 M10/10.5 RIBBED LOCK	F81055-7	4	
	MOTOREDUCER, BLADE DISTANCE SETTING DRIVE, COMPLETE	503908	1	
27	MOTOREDUCER, MR-50/78/0.18-900 K3/B8	101024	1	
28	SPROCKET, Z=13, 10B T72572, ZINC-PLATED	502382-1	1	
29	BASE, BLADE DISTANCE SETTING REDUCER, PTD	503904-1	1	
30	PLATE, MOVABLE PTD	503905-1	1	
31	BOLT, M8x20-8.8 MUSHROOM HEAD SQUARE NECK ZINC	F81002-11	1	
32	SCREW, M8x25 -8.8- HEX SOCKET HEAD CAP ZINC	F81002-21	4	
33	BOLT, M8x110 -8.8- HEX HEAD ZINC	F81002-53	2	
34	BOLT, M8x30-8.8-B-HEX HEAD FULL THREAD ZINC	F81002-7	6	
35	BOLT, M8x65 8.8 HEX HEAD FULL THREAD ZINC	F81002-9	2	
36	SCREW, M6x8 45H GEOMET	F81013-1	2	
37	NUT, M8-8-B-HEX NYLON ZINC LOCK	F81032-2	15	
38	WASHER, 8,4-LOCK ZINC	F81054-1	25	
	BLADE DISTANCE SETTING SAFETY SWITCH, COMPLETE	503910	1	
39	SWITCH, GLCB01A2B (HONEYWELL) SAFETY	086469	2	
40	BASE, SAFETY SWITCH (EDGER)	500553-1	2	
41	BOLT, M5x40-8.8-HEX HEAD FULL THREAD ZINC	F81000-74	4	
42	SCREW, M6x20 -8.8- SOCKET HEAD ZINC	F81001-22	4	
43	NUT, M5-8-DIN 985 ZINC	F81030-2	4	
44	NUT, M6-8-HEX ZINC	F81031-1	4	
45	WASHER, 5,3 FLAT ZINC	F81052-1	8	
46	WASHER, 6,4 FLAT ZINC	F81053-1	4	
	SPROCKET ASSEMBLY, COMPLETE	503914	1	
47	SPROCKET, Z14 5/8"x3/8" W/BEARING	088867	2	
48	BRACKET, SPROCKET PTD	503915-1	1	
49	BOLT, M10x35-8.8 HEX HEAD FULL THREAD ZINC	F81003-17	2	
50	BOLT, M16x60 8.8 HEX HEAD FULL THREAD ZINC	F81006-12	2	
51	NUT, M10-8-B -HEX NYLON ZINC LOCK	F81033-1	2	
52	NUT, M16-8-HEX NYLON ZINC LOCK	F81036-2	2	
53	WASHER, 10,5 FLAT ZINC	F81055-1	4	
54	WASHER, 17 FLAT ZINC	F81058-1	6	
	BLADE DISTANCE SETTING CHAIN COVER, COMPLETE	505465	1	
55	COVER, BLADE DISTANCE SETTING PTD	505466-1	1	
56	BOLT, M6x20 8.8 HEX HEAD FULL THREAD ZINC	F81001-2	3	
57	NUT, M6-8-B-HEX NYLON ZINC LOCK	F81031-2	3	
58	WASHER, 6,4 FLAT ZINC	F81053-1	6	
	BLADE AND LASER SETTING CHAIN, COMPLETE	505467	1	
59	LINK, 10B-1Pz MASTER	088671	2	
60	CHAIN, 10B-133	505468	1	
61	BOLT, M8x20-8.8 MUSHROOM HEAD SQUARE NECK ZINC	F81002-11	2	
62	NUT, M8-8-B-HEX NYLON ZINC LOCK	F81032-2	2	
63	WASHER, 8,4-FLAT ZINC	F81054-1	2	
	LASER DISTANCE SETTING DRIVE SHAFT, COMPLETE - <a href="#">See Section 8.8</a>	503921	1	
	LASER MOUNT AND GUIDE ASSEMBLY, COMPLETE - <a href="#">See Section 8.8</a>	503925	1	

**8.8 Laser Guide Assembly (EG300)**

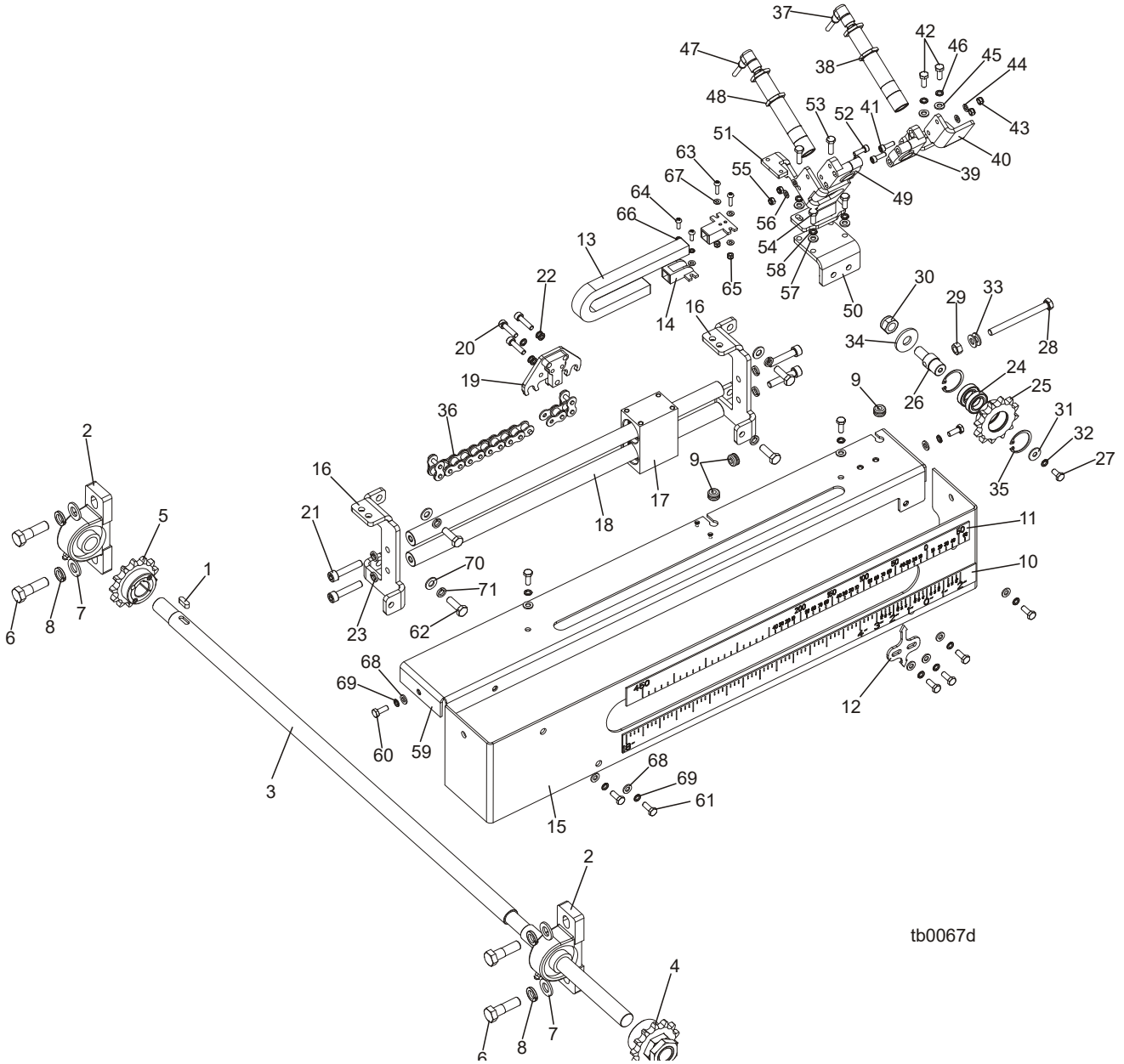

REF.	DESCRIPTION (◆ Indicates Parts Available In Assemblies Only)	PART #	QTY
	<b>LASER DISTANCE SETTING DRIVE SHAFT</b>	503921	1
1	KEY, A 6x6x18 PARALLEL	089404	1
2	BEARING, UCP 204 CX	500059	2
3	SHAFT, LASER DISTANCE SETTING DRIVE, ZINC-PLATED	503920-1	1
4	SPROCKET, Z=13, 10B W/BUSHING S203K COMPLETE	503924	1
5	SPROCKET, 3/8"/5/8" 13Z,10B-1/22 (T43993+T31013) ZINC	505481	1
6	BOLT, M12x40-8.8 HEX HEAD ZINC	F81004-1	4
7	WASHER, 13 FLAT ZINC	F81056-1	4
8	WASHER, Z12.2 SPLIT LOCK ZINC	F81056-2	4

	<b>LASER MOUNT AND GUIDE ASSEMBLY</b>	503925	1	
9	SEAL WIRE, GH6 RUBBER	085338	3	
10	SCALE, EDGER INCH	101006	1	
11	SCALE, EDGER METRIC	101007	1	
12	POINTER, BLADE SCALE	500068-1	1	
13	GUIDE, CHAIN SR20012018 (EDGER)	500621	1	
14	BRACKET, AN20012K (complete) MOUNTING	500622	1	
15	GUARD, EDGER LASER	500743-1	1	
	LASER GUIDE, COMPLETE	503916	1	
16	BRACKET, GUARDS - COMPLETE	500070-1	2	
17	BLOCK, LASER GUIDE - COMPLETE	504010	1	
18	ROD, LASER GUIDE	504359	2	
19	BRACKET, LASER CHAIN	505459-1	1	
20	SCREW, M6x25 -8.8-HEX SOCKET HEAD CAP ZINC	F81001-41	3	
21	SCREW, M8x40 -8.8- HEX SOCKET HEAD CAP ZINC	F81002-29	4	
22	WASHER, Z 6,1 SPLIT LOCK ZINC	F81053-3	5	
23	WASHER, 8,2 SPLIT LOCK ZINC	F81054-4	4	
	LASER CHAIN TENSIONER, COMPLETE	503917	1	
24	BEARING, 61903 2RS BALL	500051	2	
25	SPROCKET, Z=12, 10B-1, ZINC	503918-1	1	
26	SHAFT, TENSIONER SPROCKET, ZINC	503919-1	1	
27	BOLT, M6x12-8.8-HEX HEAD FULL THREAD ZINC	F81001-7	1	
28	BOLT, M8x90-8.8-HEX HEAD FULL THREAD ZINC	F81002-16	1	
29	NUT, M8-8-B-HEX ZINC	F81032-1	1	
30	NUT, M12-8 HEX NYLON ZINC LOCK	F81034-2	1	
31	WASHER, 6,5 SPECIAL FLAT ZINC	F81053-11	1	
32	WASHER, Z 6,1 SPLIT LOCK ZINC	F81053-3	1	
33	WASHER, 8,4-FLAT ZINC	F81054-1	2	
34	WASHER, 13 FLAT SPECIAL	F81056-12	1	
35	RING, Z28 OUTSIDE RETAINING	F81090-12	2	
36	LASER GUIDE CHAIN, COMPLETE	503926	1	
	CHAIN, 10B-89	503927	1	
	LINK, 10B-1Pz MASTER	088671	2	
	LASER W/HOUSING, COMPLETE	505469	1	
37	CABLE, 5 M	087652	1	
38	LASER, Z5M18B-F-532-IG90 LINEAR (GREEN BEAM)	501025	1	
39	BRACKET, SMB 18SF LASER	503469	1	
40	BRACKET, LASER PTD	505470-1	1	
41	SCREW, M5x16-8.8-HEX SOCKET HEAD CAP ZINC	F81000-25	2	
42	BOLT, M6x16-8.8-HEX HEAD FULL THREAD ZINC	F81001-32	2	
43	NUT, M5-8-Fe/Zn5 DIN 985	F81030-2	2	
44	WASHER, 5,3 FLAT ZINC	F81052-1	2	
45	WASHER, 6,4 FLAT ZINC	F81053-1	2	
46	WASHER, Z 6,1 SPLIT LOCK ZINC	F81053-3	2	
	MOVABLE LASER W/HOUSING, COMPLETE	505471	1	
47	CABLE, 5 M	087652	1	
48	LASER, Z5M18B-F-532-IG90 LINEAR (GREEN BEAM)	501025	1	
49	BRACKET, SMB 18SF LASER	503469	1	
50	BRACKET, INDICATOR ZINC	505462-1	1	

51	BRACKET, MOVABLE LASER PTD	505472-1	1	
52	SCREW, M5x16-8.8-HEX SOCKET HEAD CAP ZINC	F81000-25	2	
53	SCREW, M6x20 8.8 SOCKET HEAD	F81001-22	2	
54	SCREW, M6x16, HEX SOCKET HEAD CAP	F81001-21	2	
55	NUT, M5-8-Fe/Zn5 DIN 985	F81030-2	2	
56	WASHER, 5,3 FLAT ZINC	F81052-1	2	
57	WASHER, 6,4 FLAT ZINC	F81053-1	4	
58	WASHER, Z 6,1 SPLIT LOCK ZINC	F81053-3	4	
59	COVER, LASERS UPPER	505861-1	1	
60	BOLT, M6x16 8.8 HEX HEAD FULL THREAD ZINC	F81001-15	8	
61	BOLT, M6x16-8.8-HEX HEAD FULL THREAD ZINC	F81001-32	2	
62	BOLT, M8x25-8.8-B-HEX HEAD FULL THREAD ZINC	F81002-5	4	
63	SCREW, M4x16 5,8-B CROSS RECESSED PAN HEAD	F81011-42	2	
64	SCREW, M4x12 -5.8-B CROSS RECESSED PAN HEAD	F81011-43	2	
65	NUT, M4-B HEX NYLON ZINC LOCK	F81029-1	2	
66	WASHER, Z 4.1 SPLIT LOCK ZINC	F81051-1	2	
67	WASHER, 4.3 FLAT ZINC	F81051-2	6	
68	WASHER, 6.4 FLAT ZINC	F81053-1	10	
69	WASHER, 6.4 FLAT ZINC	F81053-3	10	
70	WASHER, 8.4 FLAT ZINC	F81054-1	4	
71	WASHER, 8.2 SPLIT LOCK ZINC	F81054-4	4	

## 8.9 Motor Assembly

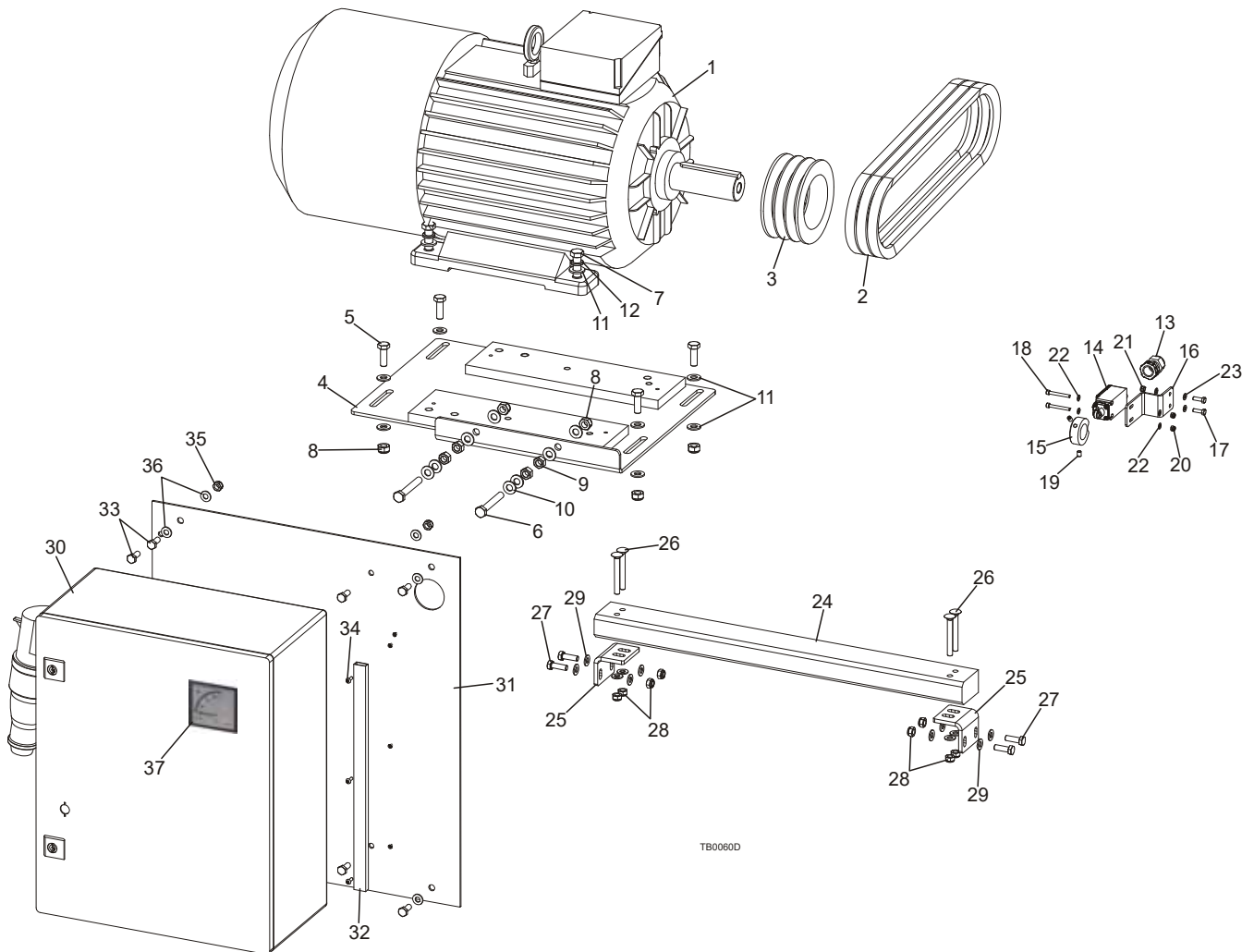

REF.	DESCRIPTION (◆ Indicates Parts Available In Assemblies Only)	PART #	QTY
	<b>EDGER MOTOR ASSEMBLY, E20 COMPLETE</b>	503183	1
	<b>EDGER MOTOR ASSEMBLY, E25 COMPLETE</b>	503189	1
1	MOTOR, 1LA7166-2AA60-Z G26+C01 (E25)	087397	1
	MOTOR ELECTR.15KW WITH BRAKE SG160M2B (E20)	087396	1
2	V-BELT, B39 1040 Lp, EDGER	101130	3
3	SHEAVE, PBT SPB3 125/42, (F02321+T31111)	503149	1
4	PLATE, E15, E20, E25 MOTOR MOUNT PTD	503190-1	1
5	BOLT, M10x30-5.8-HEX HEAD FULL THREAD ZINC	F81003-2	4
6	BOLT, M10x70-8.8-HEX HEAD FULL THREAD ZINC	F81003-20	2
7	BOLT, M12x35-8.8-HEX HEAD FULL THREAD ZINC	F81004-24	4
8	NUT, M10-8-B -HEX NYLON ZINC LOCK	F81033-1	6
9	NUT, M10-8-B-HEX ZINC	F81033-3	4
10	WASHER, 10,5 FLAT ZINC	F81055-1	16
11	WASHER, 13 FLAT ZINC	F81056-1	4
12	WASHER, Z12.2 SPLIT LOCK ZINC	F81056-2	4
	<b>HOLD-DOWN ROLLER SAFETY SWITCH, COMPLETE</b>	505860	1
13	GLAND, SKINTOP ST PG 13,5 GREY CABLE	086524	1



14	SWITCH, GLCB01C SAFETY	100910	1	
15	CAM, SAFETY SWITCH	500073	1	
16	BRACKET, SAFETY SWITCH	500140-1	1	
17	BOLT, M5x16-5.8-HEX HEAD FULL THREAD ZINC	F81000-51	2	
18	SCREW, M4x35-8.8 HEX SOCKET HEAD CAP ZINC	F81011-34	2	
19	SCREW, M6x8 45H GEOMET	F81013-1	2	
20	NUT, M4-B HEX NYLON ZINC LOCK	F81029-1	2	
21	NUT, M5-8-Fe/Zn5 DIN 985	F81030-2	2	
22	WASHER, 4.3 FLAT ZINC	F81051-2	4	
23	WASHER, 5.3 FLAT ZINC	F81052-1	4	
	<b>COMPLETE ANTI-KICKBACK BAR</b>	505858	1	
24	BAR, ANTI-KICKBACK	089055	1	
25	BRACKET, ANTI-KICKBACK BAR	505859-1	2	
26	BOLT, M8x65-8.8 MUSHROOM HEAD SQUARE NECK ZINC	F81002-24	4	
27	BOLT, M8x25-8.8-B HEX HEAD FULL THREAD ZINC	F81002-5	4	
28	NUT, M8-8-B HEX NYLON ZINC LOCK	F81032-2	8	
29	WASHER, 8.4 FLAT ZINC	F81054-1	12	
	<b>EG300 EDGER FRONT COVER - COMPLETE</b>	505489	1	
30	BOX, 400V ELECTRIC	100776	1	
31	COVER, EG300 EDGER FRONT	505487-1	1	
32	CONDUITE, LONG VERTICAL CABLE	505863	1	
33	BOLT, M8x20-8.8-B HEX HEAD FULL THREAD ZINC	F81002-4	8	
34	SCREW, M4x12-5.8-B CROSS RECESSED PAN HEAD	F81011-43	3	
35	NUT, M8-8-B-HEX NYLON ZINC LOCK	F81032-2	4	
36	WASHER, 8.4 FLAT ZINC	F81054-1	8	
37	AMMETER, EQB72 40/80A FOR E25 MOTOR	505373	1	
	AMMETER, EQB72 30/60A FOR E20 MOTOR	505372	1	

## 8.10 Control Box (EG300 CE Only)

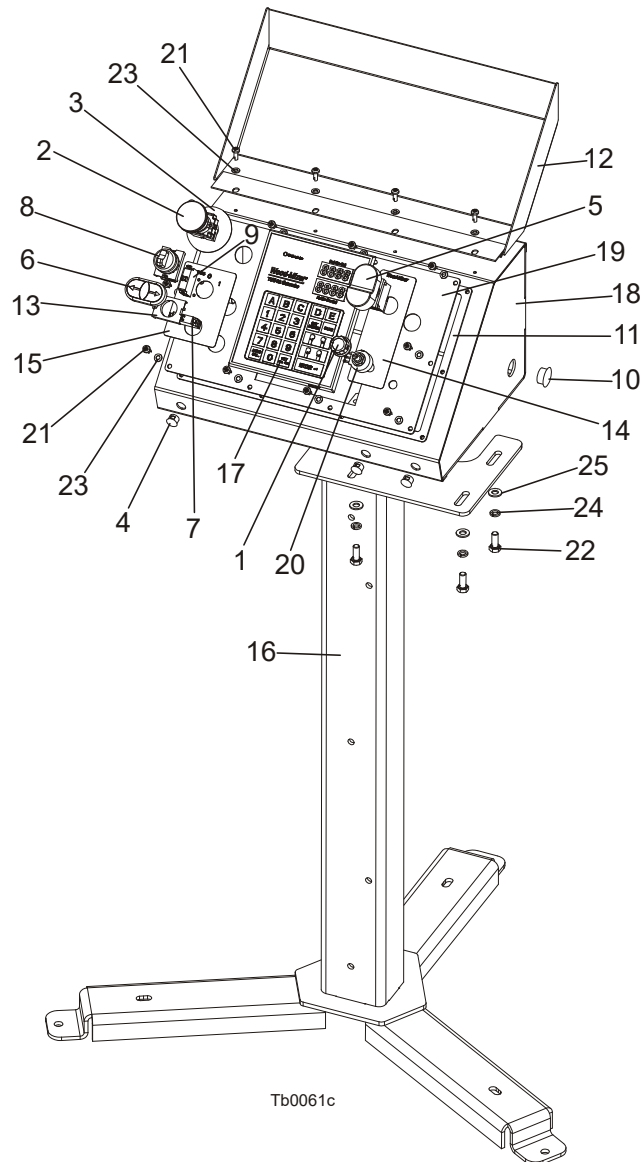

REF.	DESCRIPTION (◆ Indicates Parts Available In Assemblies Only)	PART #	QTY
	<b>EG300 EDGER CONTROL BOX - COMPLETE</b>	504374	1
1	KNOB, 1/4"ID FLUTED ROUND PLASTIC	033478	1
2	SWITCH, XB4 BS542 EMERGENCY STOP	086556	1
3	WASHER, ZBY9330 EMERGENCY STOP SWITCH	086561	1
4	CAP, 12.7 HEYMAN DP 500 #2643 HOLE	086773	3
5	SWITCH, 24V ILLUMINATED START/STOP	090452	1
6	BUTTON, M22-DDL-S-X7/X7	090917	1
7	ELEMENT, M22-K10 CONTACT	091362	1
8	SWITCH, 2POSITION KEY	091467	1
9	ELEMENT, M22-K01 CONTACT	092684	1
10	CAP, SR1086 NA OT.22,2 HOLE	093544	2
11	GASKET, CONTROL BOX	097132	1
12	COVER, LT20/40 CONTROL BOX - COMPLETE	097135-1	1

# REPLACEMENT PARTS

Control Box (EG300 CE ONLY)

8

13	LINK, M22-A	100905	1	
14	DECAL, EDGER 1 CONTROL BOX	500035	1	
15	DECAL, EDGER 2 CONTROL BOX	500035-1	1	
16	STAND, LT20B CONTROL BOX	501651-1	1	
17	CONTROLLER, TBS01	503467	1	
18	BOX, TVS CONTROL	503536-1	1	
19	PANEL, EG300 CONTROL BOX	504375-1	1	
20	POTENTIOMETER, 1k	E20519	1	
21	BOLT, #10-24 x 1/2 PH PAN HEAD TYPE 23	F05015-17	14	
22	BOLT, M8x20-8.8-B-HEX HEAD FULL THREAD ZINC	F81002-4	4	
23	WASHER, 5.3 FLAT ZINC	F81052-1	14	
24	WASHER, 8.4-FLAT ZINC	F81054-1	4	
25	WASHER, 8.2 SPLIT LOCK ZINC	F81054-4	4	

## 8.11 Electric Box (EG250)

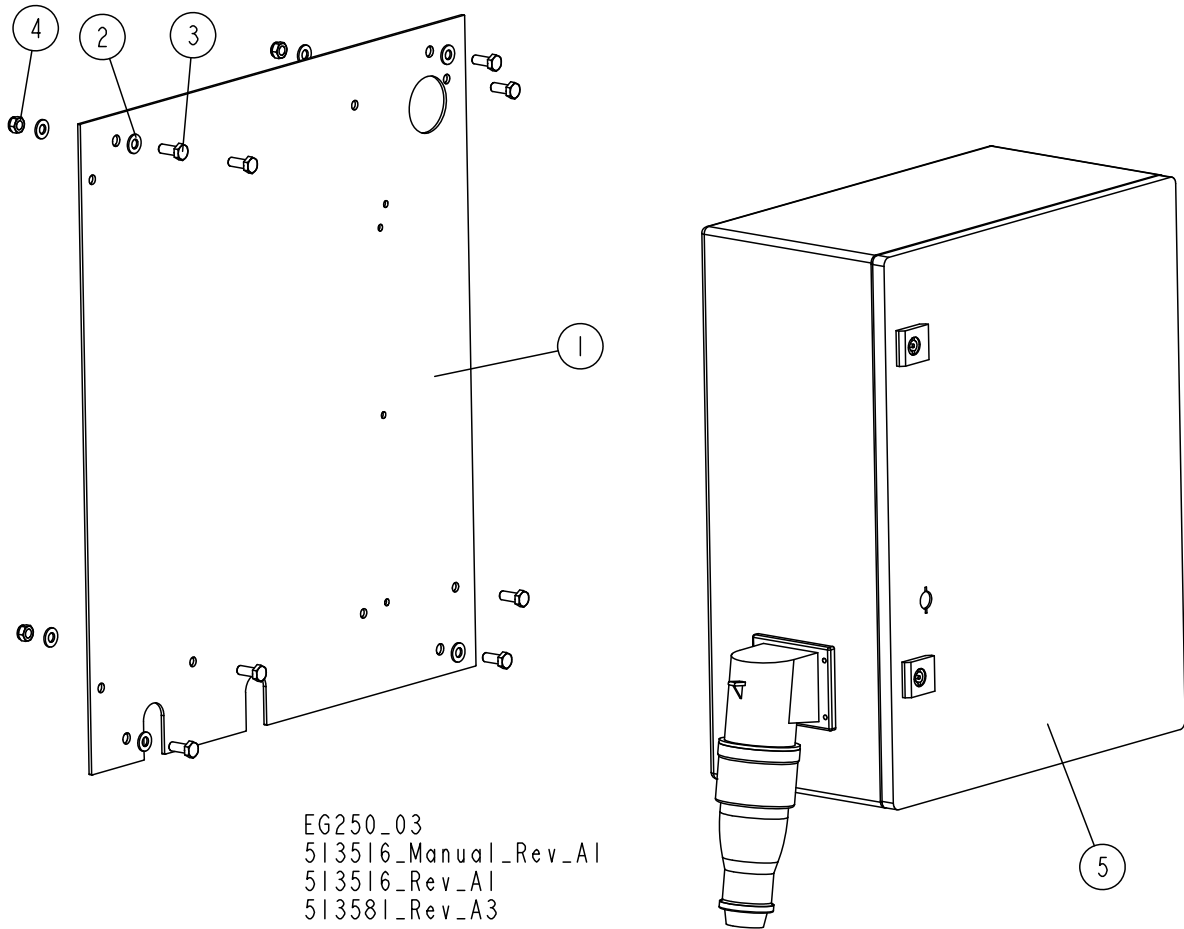

REF.	DESCRIPTION (◆ Indicates Parts Available In Assemblies Only)	PART #	QTY	
	<b>COVER, EG250 EDGER FRONT - COMPLETE</b>	<b>513581</b>	<b>1</b>	
1	PLATE, FRONT EDGER COVER	505488-1	1	
2	WASHER, 8.4 FLAT ZINC	F81054-1	8	
3	BOLT, M8X20 8.8 HEX HEAD FULL THREAD ZINC	F81002-4	8	
4	NUT, M8 8 HEX NYLON ZINC LOCK	F81032-2	4	
5	<b>BOX, EG250 ELECTRIC</b>	<b>512953</b>	<b>1</b>	

8.12 Table (EG300)

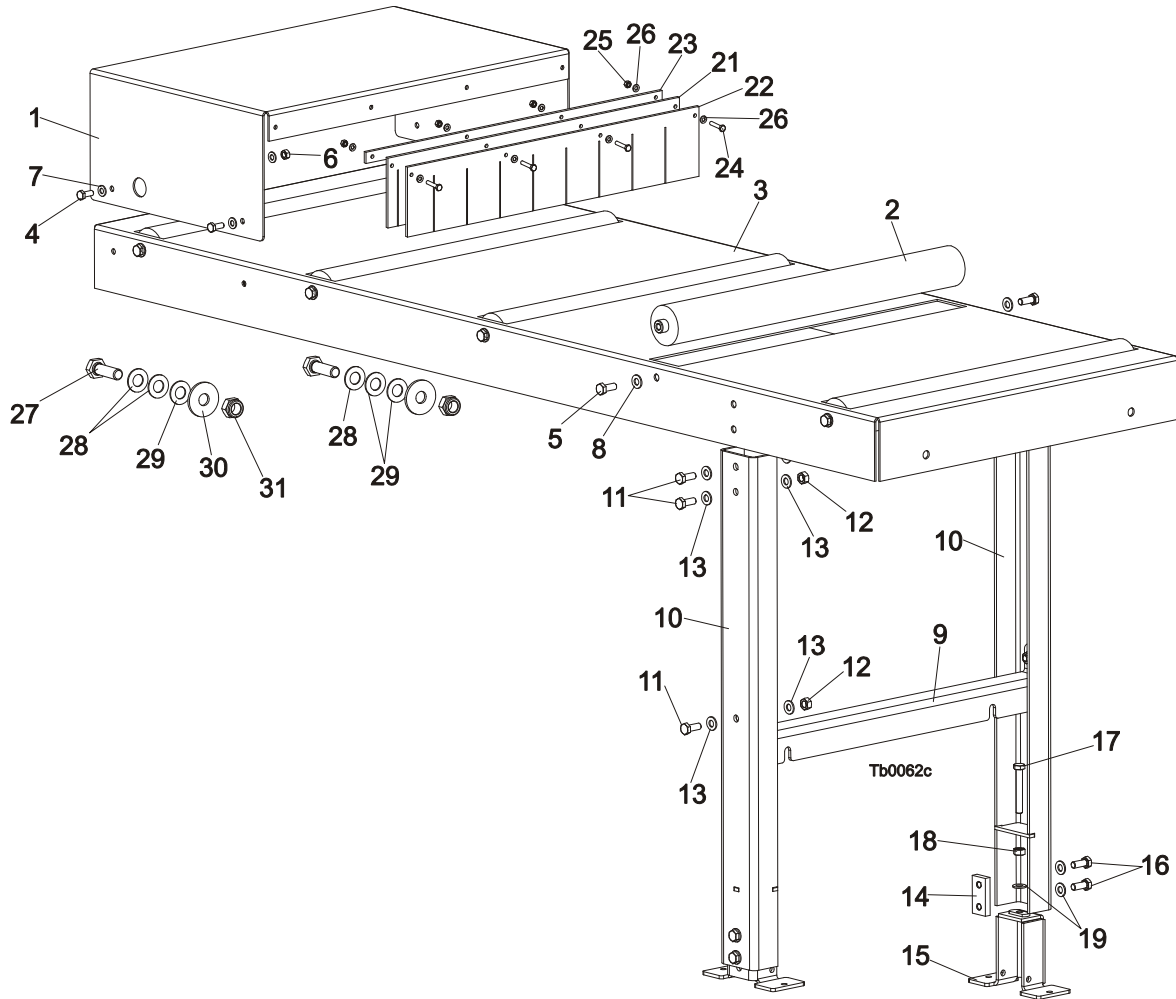

REF.	DESCRIPTION (◆ Indicates Parts Available In Assemblies Only )	PART #	QTY
	<b>TABLE, EDGER COMPLETE</b>	101400	1
1	GUARD, BOARD	099299-1	1
2	ROLLER, 63.5/20x590 (EDGER)	501090-1	5
3	TOP, TABLE	500078-1	1
4	BOLT, M8x20-5.8-HEX HEAD FULL THREAD ZINC	F81002-1	4
5	BOLT, M10x25-8.8-HEX HEAD FULL THREAD ZINC	F81003-11	10
6	NUT, M8-8-B-HEX ZINC	F81032-1	4
7	WASHER, 8.4-FLAT ZINC	F81054-1	8
8	WASHER, 10.5 FLAT ZINC	F81055-1	10
	<b>LEG, EDGER TABLE COMPLETE</b>	500118	1
9	PLATE, TABLE LEG CONNECTION	500074-1	1
10	LEG, EDGER TABLE	500076-1	2
11	BOLT, M10x25-8.8-HEX HEAD FULL THREAD ZINC	F81003-11	6
12	NUT, M10-8-B-HEX ZINC	F81033-3	6
13	WASHER, 10.5 FLAT ZINC	F81055-1	12
	<b>COMPLETE ADJUSTABLE LEG FOOT</b>	101014	2
14	PLATE, M10 CLAMPING ZINC-PLATED	101242-1	1
15	FOOT, LEG ADJUSTABLE	101022-1	1

## 8

**REPLACEMENT PARTS***Table (EG300)*

16	BOLT, M10x25-8.8-HEX HEAD FULL THREAD ZINC	F81003-11	2	
17	BOLT, M10x70-8.8-HEX HEAD FULL THREAD ZINC	F81003-20	1	
18	NUT, M10-8-B-HEX ZINC	F81033-3	1	
19	WASHER, 10.5 FLAT ZINC	F81055-1	3	
20	BOARD ENTER COVER	500143	1	
21	PLATE, 1 PLASTIC	089380	1	
22	PLATE, 2 PLASTIC	089381	1	
23	BAR, PLASTIC PLATE MOUNTING	500142-1	1	
24	BOLT, M6x30 5.8 HEX HEAD FULL THREAD ZINC	F81001-13	4	
25	NUT, M6-8-HEX ZINC	F81031-1	4	
26	WASHER, 6.4 FLAT ZINC	F81053-1	8	
27	BOLT, M12x40 8.8 HEX HEAD FULL THREAD ZINC	F81004-4	2	
28	WASHER, 13/25-1.5 STAINLESS STEEL	514080	3	
29	WASHER, 13/25-1 STAINLESS STEEL	514079	3	
30	WASHER, 13 SPECIAL FLAT ZINC	F81056-14	2	
31	NUT, M12-8 HEX NYLON ZINC LOCK	F81034-2	2	

**8.13 Table (Option for EG250 Edgers)**

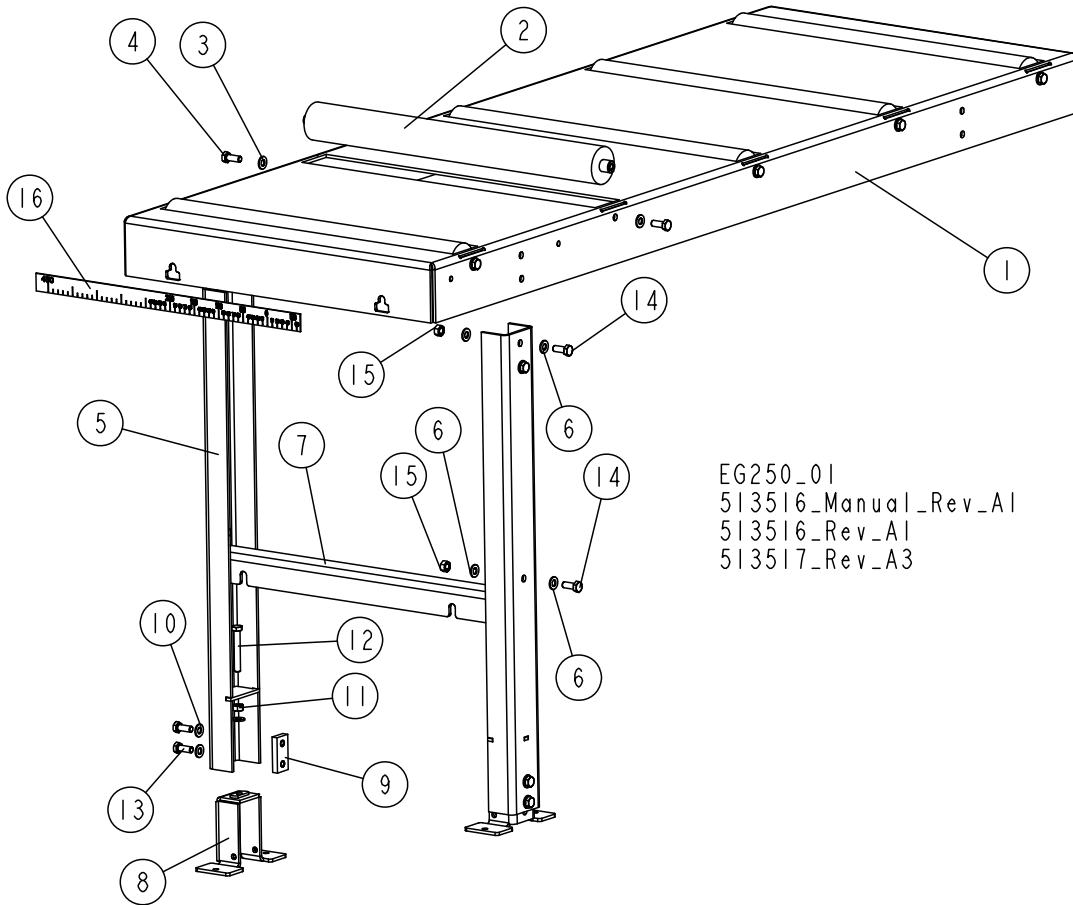

REF.	DESCRIPTION (◆ Indicates Parts Available In Assemblies Only )	PART #	QTY
	<b>TABLE, EDGER COMPLETE (W/O GUARDS)</b>	<b>513517</b>	<b>1</b>
1	TOP, IND EDGER TABLE	512488-1	1
2	ROLLER, 63.5/20X590	501090-1	5
3	WASHER,10.5 FLAT ZINC	F81055-1	10
4	BOLT, M10X25 8.8 HEX HEAD FULL THREAD ZINC	F81003-11	10
	<b>LEG, EDGER TABLE - COMPLETE</b>	<b>500118</b>	<b>1</b>
5	LEG, EDGER TABLE	500076-1	2
6	WASHER, 10.5 FLAT ZINC	F81055-1	11
7	PLATE, TABLE LEG CONNECTION	500074-1	1
	<b>COMPLETE ADJUSTABLE LEG FOOT</b>	<b>101014</b>	<b>2</b>
8	FOOT, ADJUSTABLE	101022-1	1
9	PLATE, M10 ZINC-PLATED CLAMPING	101242-1	1
10	WASHER, 10.5 FLAT ZINC	F81055-1	3
11	NUT, M10 8 HEX ZINC	F81033-3	1
12	BOLT, M10X70 8.8 HEX HEAD FULL THREAD ZINC	F81003-20	1
13	BOLT, M10X25 8.8 HEX HEAD FULL THREAD ZINC	F81003-11	2
14	BOLT, M10X25 8.8 HEX HEAD FULL THREAD ZINC	F81003-11	5
15	NUT, M10 8 HEX ZINC	F81033-3	5
16	SCALE, EDGER METRIC	101007	1

## 8.14 Board Guide Fence

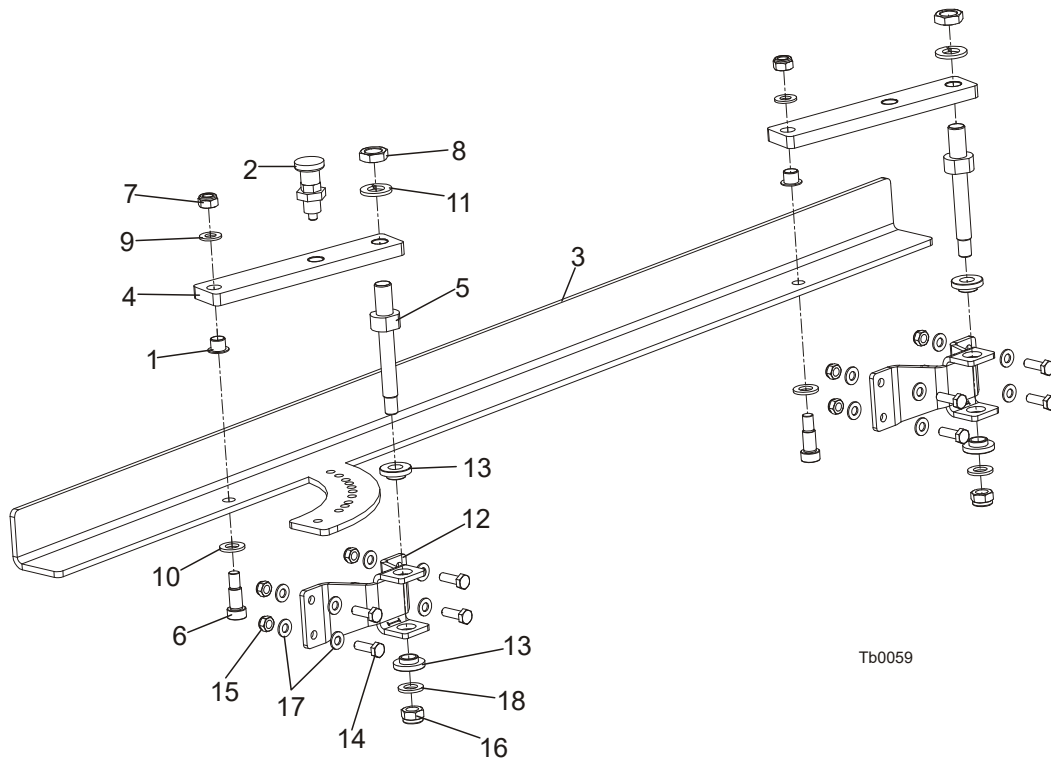

REF.	DESCRIPTION (◆ Indicates Parts Available In Assemblies Only)	PART #	QTY
	<b>COMPLETE BOARD GUIDE FENCE</b>	101100	1
	FENCE, BOARD GUIDE	101020	1
1	BUSHING, XFM-1214-12 FLANGED	088934	2
2	PIN, DETENT	090197	1
3	FENCE, GUIDE	101097-1	1
4	BAR, GUIDE FENCE ARM	101098-1	2
5	PIN, GUIDE FENCE ARM ZINC-PLATED	101099-1	2
6	BOLT, 12/M10x20 12.9 ISO7379 (BOSSARD) SHOULDER	F81003-68	2
7	NUT, M10-8-B HEX NYLON ZINC LOCK	F81033-1	2
8	NUT, M16x1.5-08-B-HEX THIN ZINC	F81036-6	2
9	WASHER, 10.5 FLAT ZINC	F81055-1	2
10	WASHER, 13 FLAT ZINC	F81056-1	2
11	WASHER, 16.3 SPLIT LOCK ZINC	F81058-2	2
12	BRACKET, BOARD GUIDE FENCE	101102-1	2
13	BUSHING, BOARD GUIDE FENCE	101411	4
14	BOLT, M8x25-8.8-B HEX HEAD FULL THREAD ZINC	F81002-5	8
15	NUT, M8-8-B HEX NYLON ZINC LOCK	F81032-2	8
16	NUT, M12-8 HEX NYLON ZINC LOCK	F81034-2	2
17	WASHER, 8.4 FLAT ZINC	F81054-1	16
18	WASHER, 13 FLAT ZINC	F81056-1	2



8.15 Covers

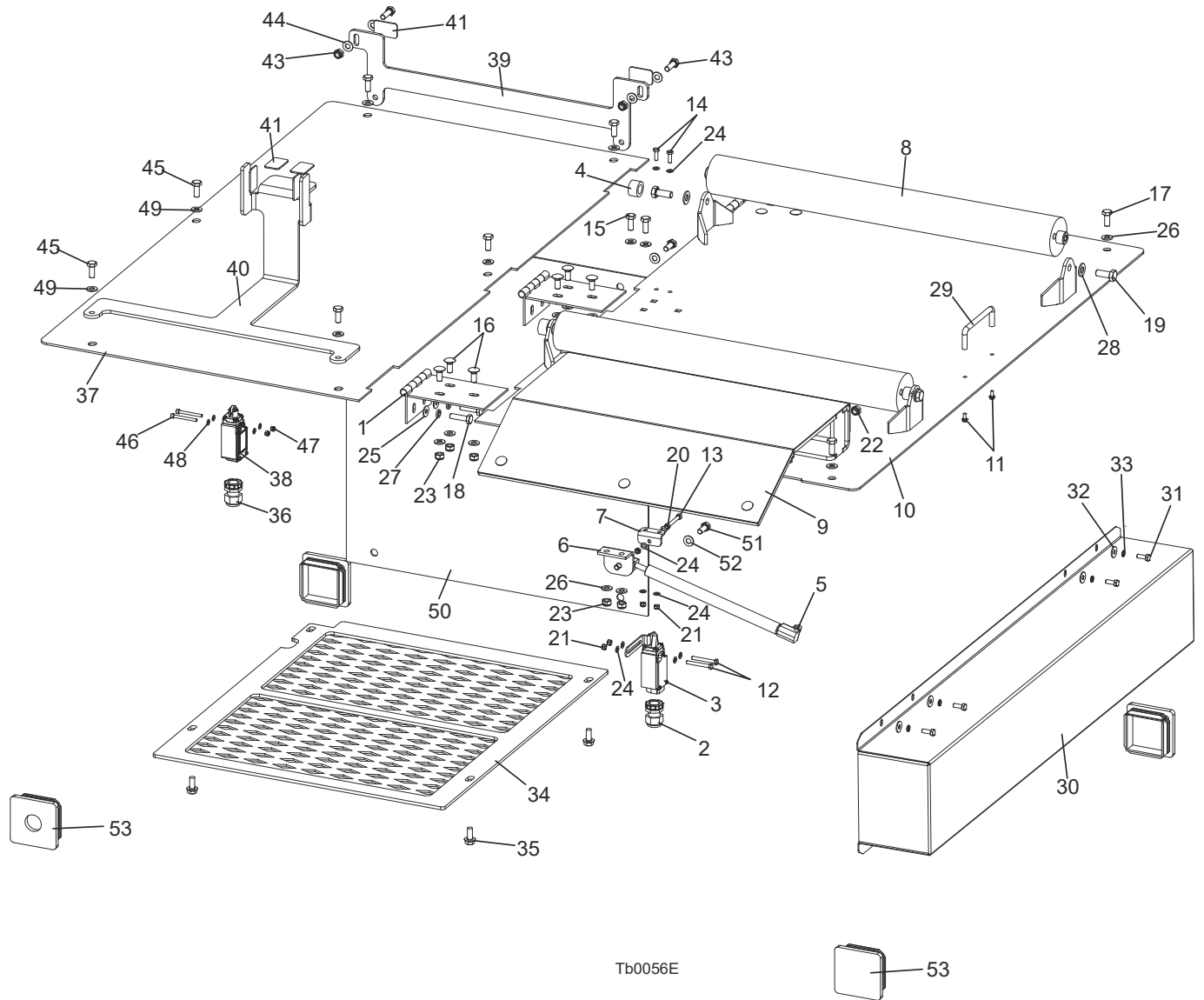

Tb0056E

REF.	DESCRIPTION (◆ Indicates Parts Available In Assemblies Only)	PART #	QTY
	<b>COVER, UPPER LEFT HINGED - COMPLETE</b>	505484	1
1	HINGE, COMPLETE	038136-1	3
2	GLAND, SKINTOP ST PG 13,5 GREY CABLE	086524	1
3	SWITCH, GSCA 01S1 SAFETY	088407	1
4	CAP, BUMPER RUNNER No 646	089083	2
5	SPRING, 340N GAS COMPLETE	089212	1
6	BRACKET, GAS SPRING	089213-1	1
7	BRACKET, SAFETY SWITCH CAM	089225-1	1
8	ROLLER, 63.5/20x590 PTD. (EDGER)	501090-1	2
9	COVER, EDGER LASER - COMPLETE	500755	1
10	COVER, UPPER HINGED	505485-1	1
11	SCREW, #8-32x3/8 SELF-TAPPING 4.2x13HW	F05015-8	2
12	BOLT, M5x40-8.8-HEX HEAD FULL THREAD ZINC	F81000-74	2
13	SCREW, M5x45 DIN912 A2-70 HEX SOCKET HEAD	F81000-24	1

14	BOLT, M5x16-5.8-HEX HEAD FULL THREAD ZINC	F81000-51	2	
15	BOLT, M8x20-5.8-HEX HEAD FULL THREAD ZINC	F81002-1	2	
16	BOLT, M8x20-8.8 MUSHROOM HEAD SQUARE NECK ZINC	F81002-11	13	
17	BOLT, M8x20-8.8-B-HEX HEAD FULL THREAD ZINC	F81002-4	2	
18	BOLT, M8x30-8.8-B-HEX HEAD FULL THREAD ZINC	F81002-7	2	
19	BOLT, M10x25-8.8-HEX HEAD FULL THREAD ZINC	F81003-11	4	
20	NUT, M5-8-HEX ZINC	F81030-1	1	
21	NUT, M5-8-ZINC DIN 985	F81030-2	5	
22	NUT, M8-8-B HEX ZINC	F81032-1	2	
23	NUT, M8-8-B-HEX NYLON ZINC LOCK	F81032-2	15	
24	WASHER, 5.3 FLAT ZINC	F81052-1	10	
25	WASHER, 6.5 SPECIAL FLAT ZINC	F81053-11	2	
26	WASHER, 8.4-FLAT ZINC	F81054-1	19	
27	WASHER, 8.2 SPLIT LOCK ZINC	F81054-4	2	
28	WASHER, 10.5 FLAT ZINC	F81055-1	4	
29	HANDLE, BLADE COVER	P08065	1	
	<b>INFEED ROLLERS SIDE COVER - COMPLETE</b>	503892	1	
30	COVER, INFEED ROLLER SIDE	515402-1	1	
31	BOLT, M6x16 8.8 HEX HEAD FULL THREAD ZINC	F81001-15	8	
32	WASHER, 6.5 SPECIAL FLAT ZINC	F81053-11	8	
33	WASHER, Z 6.1 SPLIT LOCK ZINC	F81053-3	8	
	<b>COVER, EDGER DRIVE BOTTOM - COMPLETE</b>	503894	1	
34	COVER, EDGER DRIVE BOTTOM	505492-1	1	
35	SCREW, 5/16-18 x 3/4 SELF-TAPPING	F05015-30	4	
	<b>UPPER RIGHT COVER - COMPLETE</b>	503896	1	
36	GLAND, SKINTOP ST PG 13,5 GREY CABLE	086524	1	
37	COVER, RIGHT HINGED	089108-1	1	
38	SWITCH, GLCB01C SAFETY	100910	1	
	<b>HOLDER, EDGER CONTROL BOX TRANSPORT COMPLETE</b>	503899	1	
39	HOLDER, 1 EDGER CONTROL BOX TRANSPORT	501078-1	1	
40	HOLDER, 2 EDGER CONTROL BOX TRANSPORT	501079-1	1	
41	WASHER, CORK	502881	6	
42	BOLT, M8x25-8.8-B-HEX HEAD FULL THREAD ZINC	F81002-5	2	
43	NUT, M8-8-B-FeZn5 HEX NYLON ZINC LOCK	F81032-2	2	
44	WASHER, 8.4 FLAT ZINC	F81054-1	4	
45	BOLT, M8x20-8.8-B-HEX HEAD FULL THREAD ZINC	F81002-4	6	
46	SCREW, M4x40-8.8 SOCKET HEAD ZINC	F81011-37	2	
47	NUT, M4-B HEX NYLON ZINC LOCK	F81029-1	2	
48	WASHER, 4.3 FLAT ZINC	F81051-2	4	
49	WASHER, 8.4 FLAT ZINC	F81054-1	6	
	<b>REAR COVER - COMPLETE</b>	505857	1	
50	COVER, REAR	089107-1	1	
51	BOLT, M8x20-8.8-B-HEX HEAD FULL THREAD ZINC	F81002-4	4	
52	WASHER, 8.4 FLAT ZINC	F81054-1	4	
53	<b>CAP, EDGER FRAME</b>	089644	4	

**8.16 EG250 Edger Top Cover**

EG250\_04  
513516\_Manual\_Rev\_AI  
513516\_Rev\_AI  
513518\_Rev\_AI

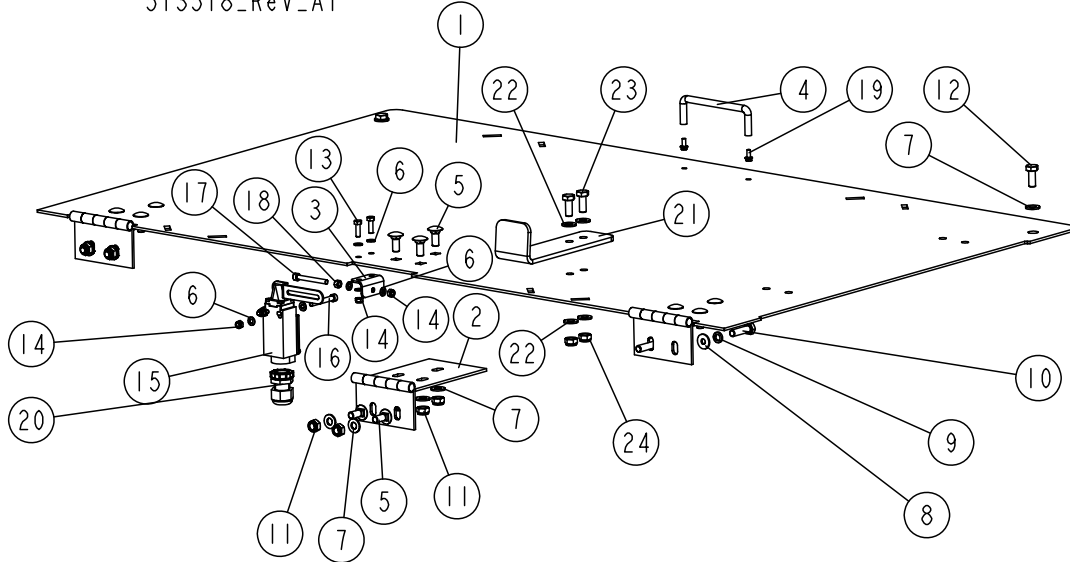

REF.	DESCRIPTION (◆ Indicates Parts Available In Assemblies Only)	PART #	QTY
	<b>COVER, LEFT TOP HINGED - COMPLETE</b>	<b>513518</b>	<b>1</b>
1	COVER, TOP HINGED	505486-1	1
2	HINGE, COMPLETE	038136-1	3
3	BRACKET, SAFETY SWITCH CAM	089225-1	1
4	HANDLE, 4"	P08065	1
5	BOLT, M8x20-8.8 MUSHROOM HEAD SQUARE NECK ZINC	F81002-11	13
6	WASHER, 5.3 FLAT ZINC	F81052-1	10
7	WASHER, 8.4 FLAT ZINC	F81054-1	15
8	WASHER, 6.5 SPECIAL FLAT ZINC	F81053-11	2
9	WASHER, 8.2 SPLIT LOCK ZINC	F81054-4	2
10	BOLT, M8X30 8.8 HEX HEAD FULL THREAD ZINC	F81002-7	2
11	NUT, M8 8 HEX NYLON ZINC LOCK	F81032-2	13
12	BOLT, M8X20 8.8 HEX HEAD FULL THREAD ZINC	F81002-4	2
13	BOLT, M5X16-5.8 HEX HEAD FULL THREAD ZINC	F81000-51	2
14	NUT, M5-8-FE/ZN5 DIN985 NYLON LOCK	F81030-2	5
15	SWITCH, GSCA 01S1 SAFETY	088407	1
16	SCREW, M5X40 8.8 HEX SOCKET HEAD CAP ZINC	F81000-74	2
17	SCREW, M5X45 DIN912 A2-70 HEX SOCKET HEAD CAP STAINLESS	F81000-24	1
18	NUT, M5 8 HEX ZINC	F81030-1	1
19	SCREW, #8-32X3/8 4.2X13HW SELF-TAPPING	F05015-8	2
20	GLAND, PG13.5 CABLE	086524	1
21	ANGLE, COVER STOP	513872-1	1
22	WASHER, 8.4 FLAT ZINC	F81054-1	4
23	BOLT, M8X20 8.8 HEX HEAD FULL THREAD ZINC	F81002-4	2
24	NUT, M8 8 HEX NYLON ZINC LOCK	F81032-2	2

## 8.17 Manual Blade Setting Assembly (EG250)

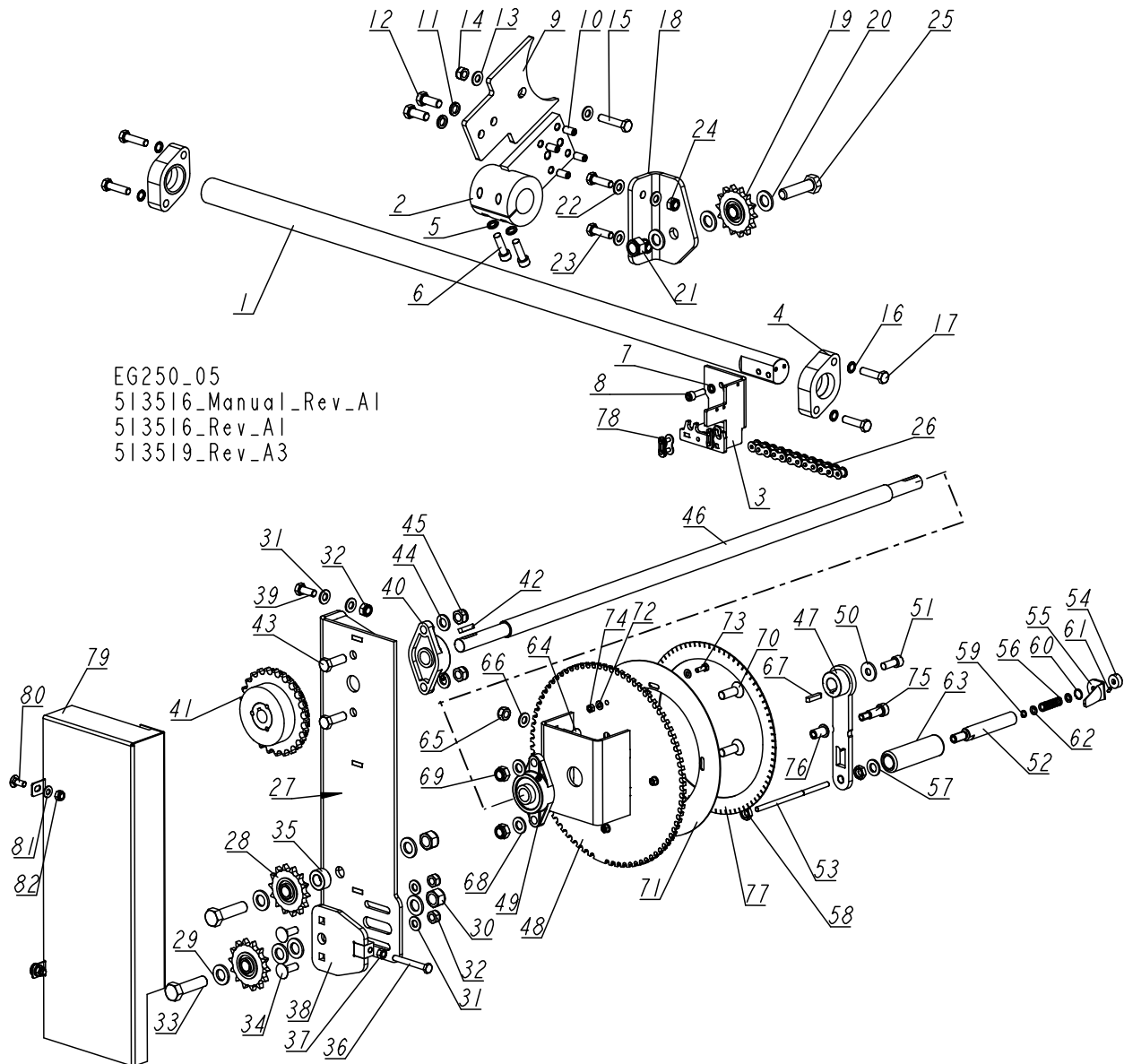

REF.	DESCRIPTION (◆ Indicates Parts Available In Assemblies Only)	PART #	QTY
	<b>DRIVE ASSEMBLY, MANUAL BLADE SETTING</b>	<b>513519</b>	<b>1</b>
	<b>SHAFT, MOVING BLADE SLIDE - COMPLETE</b>	<b>513522</b>	<b>1</b>
1	SHAFT, BLADE SLIDE BRACKET	101417-1	1
2	BRACKET, BLADE SLIDE	101009-1	1
3	BRACKET, BLADE SLIDE CHAIN HOLDER	503911-1	1
4	BEARING, COMPLETE	089134	2
5	WASHER, Z 10.2 SPLIT LOCK ZINC	F81055-2	2
6	SCREW, M10X35-8.8 HEX SOCKET HEAD CAP ZINC	F81003-56	2
7	WASHER, 8.2 SPLIT LOCK ZINC	F81054-4	2
8	SCREW, M8X25 8.8 HEX SOCKET HEAD CAP ZINC	F81002-21	2
9	PLATE, BLADE SLIDE ZINC-PLATED	500549-1	1
10	SCREW, M10X1X20 DIN 913 STAINLESS STEEL SET	F81015-1	4
11	WASHER, Z12.2 SPLIT LOCK ZINC	F81056-2	2

# REPLACEMENT PARTS

## Manual Blade Setting Assembly (EG250)

8

REF.	DESCRIPTION (◆ Indicates Parts Available In Assemblies Only)	PART #	QTY
12	BOLT, M12X30 8.8 HEX HEAD FULL THREAD ZINC	F81004-22	2
13	WASHER, 10.5 FLAT ZINC	F81055-1	2
14	NUT, M10-8-B HEX NYLON ZINC LOCK	F81033-1	1
15	BOLT, M10X50-8.8 HEX HEAD FULL THREAD ZINC	F81003-4	1
16	WASHER, 791 M10/10.5 RIBBED LOCK	F81055-7	4
17	BOLT, M10X40-8.8 HEX HEAD FULL THREAD ZINC	F81003-16	4
	<b>SPROCKET ASSEMBLY, MANUAL BLADE SETTING</b>	<b>513523</b>	<b>1</b>
18	BRACKET, SPROCKET MOUNT	513524-1	1
19	SPROCKET, Z14 5/8"x3/8" W/BEARING	088867	1
20	WASHER, 17 SPLIT LOCK ZINC	F81058-1	3
21	NUT, M16-8 HEX NYLON ZINC LOCK	F81036-2	1
22	WASHER, 10.5 FLAT ZINC	F81055-1	4
23	BOLT, M10X35 8.8 HEX HEAD FULL THREAD ZINC	F81003-17	2
24	NUT, M10-8-B HEX NYLON ZINC LOCK	F81033-1	2
25	BOLT, M16X60-8.8 HEX HEAD FULL THREAD ZINC	F81006-12	1
26	CHAIN, 10B-1 L=2206.6	513667	1
	<b>SPROCKET ASSEMBLY, MANUAL BLADE SETTING</b>	<b>513525</b>	<b>1</b>
27	BRACKET WELDMENT, SPROCKET MOUNT	513631-1	1
28	SPROCKET, Z14 5/8"x3/8" W/BEARING	088867	2
29	WASHER, 17 SPLIT LOCK ZINC	F81058-1	6
30	NUT, M16-8 HEX NYLON ZINC LOCK	F81036-2	2
31	WASHER, 10.5 FLAT ZINC	F81055-1	10
32	NUT, M10-8-B HEX NYLON ZINC LOCK	F81033-1	6
33	BOLT, M16X60-8.8 HEX HEAD FULL THREAD ZINC	F81006-12	2
34	BOLT, M10X30-8.8 CARRIAGE HEAD ZINC	F81003-101	2
35	BUSHING, 16.5/25-14 SPACER ZINC	501415-1	1
36	BOLT, M8X65 8.8 HEX HEAD FULL THREAD ZINC	F81002-9	1
37	NUT, M8-8-B HEX ZINC	F81032-1	1
38	PLATE WELDMENT, CHAIN TENSION	513582-1	1
39	BOLT, M10X25 8.8 HEX HEAD FULL THREAD ZINC	F81003-11	4
40	BEARING, UCFL 204 (CX).	500060	1
41	SPROCKET T43999 + TAPER LOCK T31101	513529	1
42	KEY, A6X6X30 PARALLEL	094245	1
43	BOLT, M12X35 8.8 HEX HEAD FULL THREAD ZINC	F81004-24	2
44	WASHER, 13 FLAT ZINC	F81056-1	2
45	NUT, M12-8 HEX NYLON ZINC LOCK	F81034-2	2
46	SHAFT, BLADE SETTING DRIVE	513530-1	1
	<b>CRANK HANDLE &amp; DIAL ASSEMBLY</b>	<b>513605</b>	<b>1</b>
47	HANDLE WELDMENT, CRANK	513598-1	1
48	DIAL WELDMENT	513601-1	1
49	BEARING, UCFL 204 (CX)	500060	1
50	WASHER, 10.5 SPECIAL FLAT ZINC	F81055-6	1
51	SCREW, M10X25 8.8 HEX SOCKET HEAD CAP ZINC	F81003-32	1
	<b>KNOB, PLASTIC CRANK HANDLE</b>	<b>096499</b>	<b>1</b>
52	MANDREL, CRANK HANDLE KNOB	096504-1	1
53	PIN, CRANK HANDLE KNOB	097095-1	1
54	RING, 7 STOPPING LIGHT TYPE	F81039-9	1
55	PLATE, EDGER HANDLE	047689	1

**REPLACEMENT PARTS***Manual Blade Setting Assembly (EG250)*

REF.	DESCRIPTION (◆ Indicates Parts Available In Assemblies Only )	PART #	QTY	
56	SPRING, 1/2 OD X 1-1/2 LENGTH X .055	047690	1	
57	WASHER, 13 FLAT ZINC	F81056-1	1	
58	NUT, M12-04-A THIN	F81034-6	2	
59	RING, Z7 OUTSIDE RETAINING	F81090-17	1	
60	RING, W13 INSIDE RETAINING	F81090-18	1	
61	SCREW, M4X8 GEOMET HEX SOCKET SET W/CONE POINT	F81011-40	1	
62	WASHER, 7.2/12.5	097264	2	
63	TUBE, CRANK HANDLE KNOB	097263	1	
64	BOLT, Z M10X25-8.8 CARRIAGE HEAD ZINC	F81003-59	2	
65	NUT, M10-8-B HEX NYLON ZINC LOCK	F81033-1	2	
66	WASHER, 10.5 FLAT ZINC	F81055-1	2	
67	KEY, A6X6X30 PARALLEL	094245	1	
68	WASHER, 13 FLAT ZINC	F81056-1	2	
69	NUT, M12-8 HEX NYLON ZINC LOCK	F81034-2	2	
70	SCREW, M12X35-8.8 DIN7991 FLAT SOCKET HEAD CAP ZINC	F81004-69	2	
71	PLATE, DIAL SCALE	513852-1	1	
72	WASHER, 6.4 FLAT ZINC	F81053-1	8	
73	BOLT, M6X16-8.8 HEX HEAD FULL THREAD ZINC	F81001-15	4	
74	NUT, M6 8 HEX ZINC	F81031-1	4	
75	BOLT, 12/M10X25 12.9 ISO7379 (BOSSARD) SHOULDER	F81003-84	1	
76	NUT, M10X13X22 RIVET ZINC-PLATED	F81033-15	1	
77	DECAL, DIAL SCALE	513851	1	
78	LINK, 10B-1PZ MASTER	088671	2	
79	GUARD, DRIVE SPROCKET	513606-1	1	
80	BOLT, M8X20-8.8 CARRIAGE HEAD ZINC	F81002-11	2	
81	WASHER, 8.4 FLAT ZINC	F81054-1	2	
82	NUT, M8 8 HEX NYLON ZINC LOCK	F81032-2	2	

**8.18 Sawdust Hopper (EG300 and EG250 CE Version)**

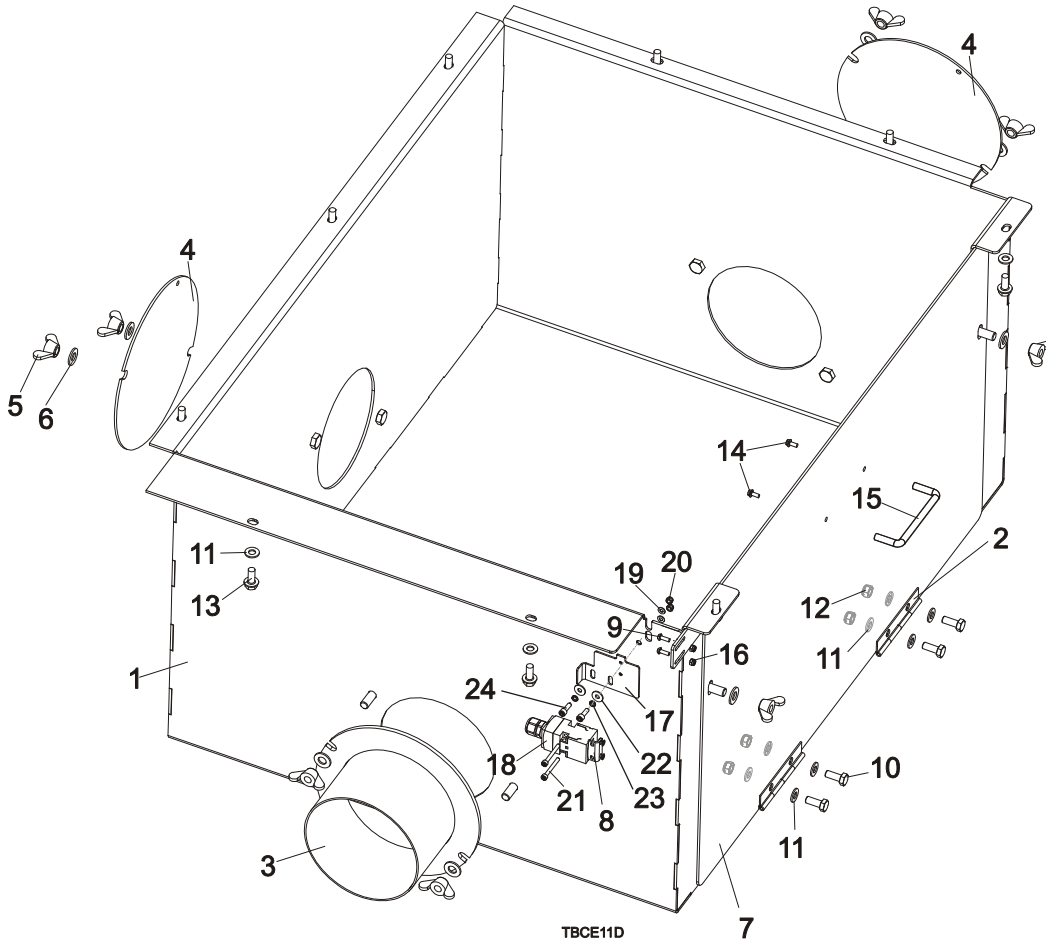

REF.	DESCRIPTION (◆ Indicates Parts Available In Assemblies Only)	PART #	QTY
	<b>HOPPER ASSEMBLY, EDGER SAWDUST DEEP</b>	<b>101103</b>	<b>1</b>
1	HOPPER WELDMENT, SAWDUST	101104-1	1
2	Hinge, Cover	089356	2
3	Tube Weldment, Sawdust Exhaust System Connector	095412-1	1
4	Cover, Hopper Hole Ptd	095413-1	2
5	Nut, M10 Wing Zinc	F81033-8	8
6	Washer, 10.5 Flat Zinc	F81055-1	8
7	Cover, Hopper Hinged	100689-1	1
8	Key, AZ17/170-B5 Safety Switch	094422	1
9	Screw, M4x12 5,8-B Cross Recessed Pan Head	F81011-43	2
10	Bolt, M8x20-8.8-B Hex Head Full Thread Zinc	F81002-4	4
11	Washer, 8.4 Flat Zinc	F81054-1	17
12	Nut, M8-8-B Hex Nylon Zinc Lock	F81032-2	4
13	Screw, 5/16-18 x 3/4 Self-Tapping	F05015-30	9
14	Screw, #8-32x3/8, Self-Tapping	F05015-8	2
15	Handle, Blade Cover	P08065	1
16	Nut, M4-B Hex Nylon Zinc Lock	F81029-1	2
	<b>EG300 SAWDUST HOPPER SAFETY SWITCH W/MOUNT BRACKET - COMPLETE</b>	<b>507537</b>	<b>1</b>
17	BRACKET, AZ17-11ZRK SAFETY SWITCH MOUNT	507538-1	1

**8****REPLACEMENT PARTS***Sawdust Hopper (EG300 and EG250 CE Version)*

18	SWITCH, AZ17-11ZRK SAFETY	094232	1	
19	WASHER, 4.3 FLAT ZINC	F81051-2	2	
20	NUT, M4-B HEX NYLON ZINC LOCK	F81029-1	2	
21	SCREW, M4X35 -8.8 HEX SOCKET HEAD CAP ZINC	F81011-34	2	
22	WASHER, 6.5 SPECIAL FLAT ZINC-PL.	F81053-11	2	
23	WASHER, Z 6.1 SPLIT LOCK ZINC	F81053-3	2	
24	SCREW, M6X16 -8.8 HEX SOCKET HEAD CAP ZINC	F81001-21	2	



**8.19 Safety Cover, EG250 E15 (CE Version)**

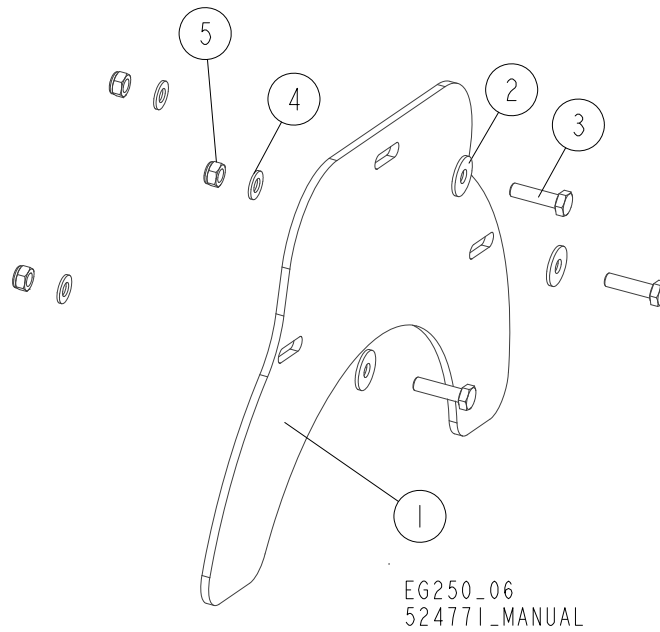

REF.	DESCRIPTION (◆ Indicates Parts Available In Assemblies Only )	PART #	QTY	
	COVER ASSEMBLY, SAFETY	524771	1	
1	COVER, SAFETY	520528-1	1	
2	WASHER, ISO 7093-1-8-200 HV-A2E	F81054-11	3	
3	BOLT, M8X30 8.8 HEX HEAD FULL THREAD ZINC	F81002-7	3	
4	WASHER, 8.4 FLAT ZINC	F81054-1	3	
5	NUT, M8-8-B HEX NYLON ZINC LOCK	F81032-2	3	

## 8.20 EG300 Edger Decals

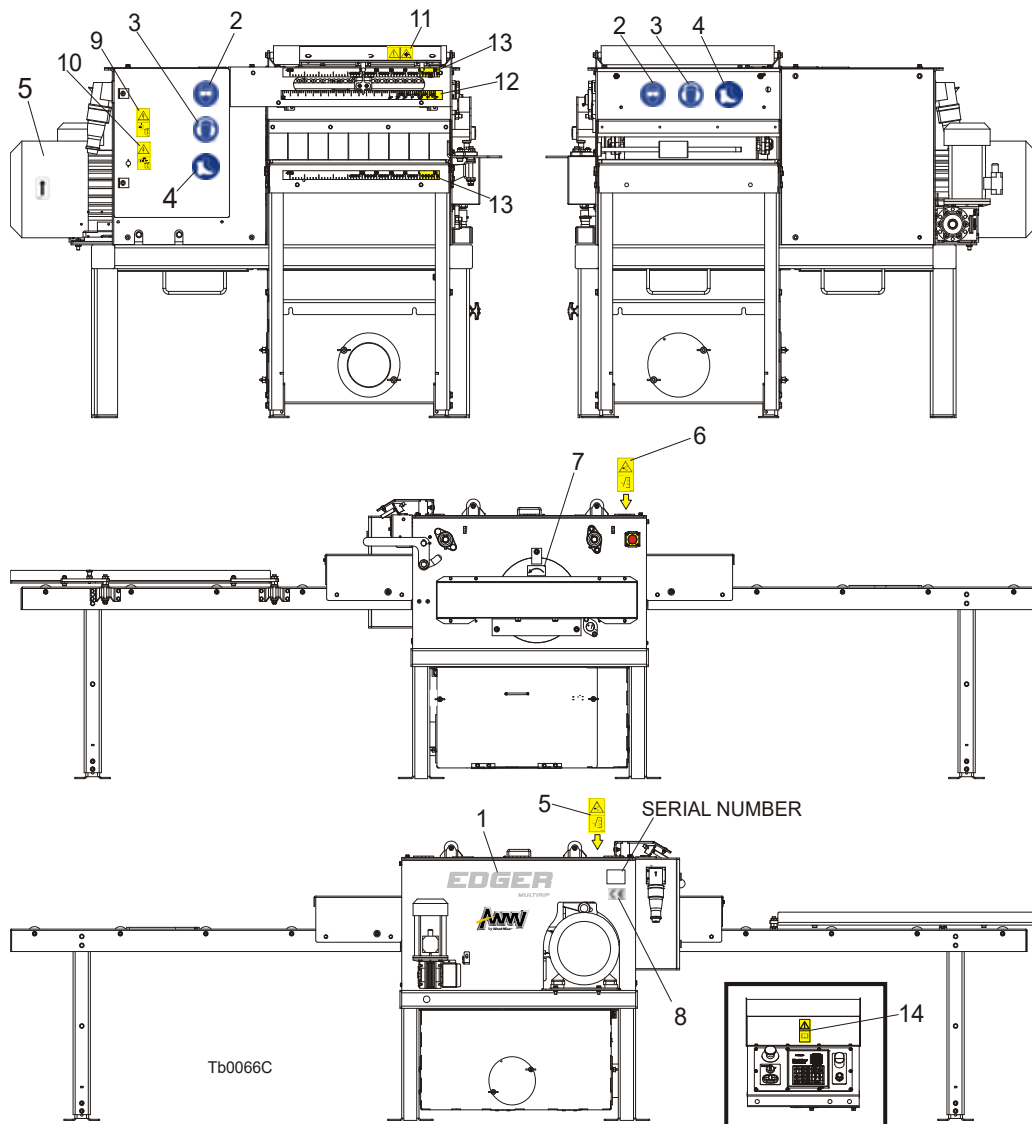

REF.	DESCRIPTION (◆ Indicates Parts Available In Assemblies Only)	PART #	QTY
	<b>DECAL KIT, EDGER W/ELECTRICAL BLADE SETTING</b>	<b>500995</b>	<b>1</b>
1	DECAL KIT, MACHINE NAME	099586	1
	PICTOGRAPHIC DECAL KIT, EDGER	099520	1
2	DECAL, EYE PROTECTION WARNING (PICTOGRAM)	S12004G	2
3	DECAL, EAR PROTECTION WARNING (PICTOGRAM)	S12005G	2
4	DECAL, USE SAFETY BOOTS (PICTOGRAM)	501465	2
5	DECAL, MOTOR ROTATION DIRECTION	S20097	1
6	DECAL, SAWMILL COVERS CAUTION	099220	2
7	DECAL, ROTATION DIRECTION	089296	1
8	DECAL, CE CERTIFIED	P85070	1
9	DECAL, HIGH VOLTAGE INSIDE THE ELECTRIC BOX (PICTOGRAM)	096316	1
10	DECAL, REMOVE THE PLUG BEFORE OPENING THE BOX (PICTOGRAM)	096319	1
11	DECAL, CAUTION - LASER BEAM (PICTOGRAM)	099504	1
12	SCALE, EDGER INCH	101006	1

**REPLACEMENT PARTS**  
*EG300 Edger Decals*

**8**

<b>13</b>	SCALE, EDGER METRIC	101007	2	
<b>14</b>	DECAL, READ THE MANUAL BEFORE OPERATING THE MACHINE	096317	1	

8.21 EG250 Edger Decals

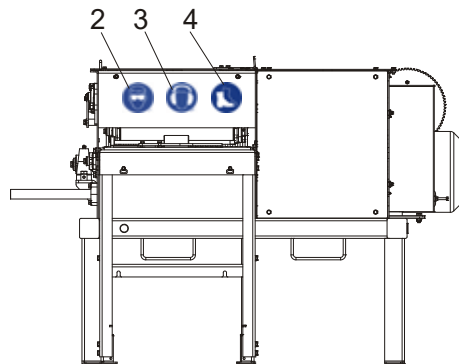
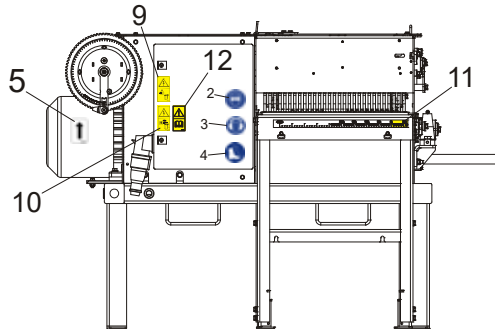

513516\_manuals\_oper rev.A  
tb0066e rev.A

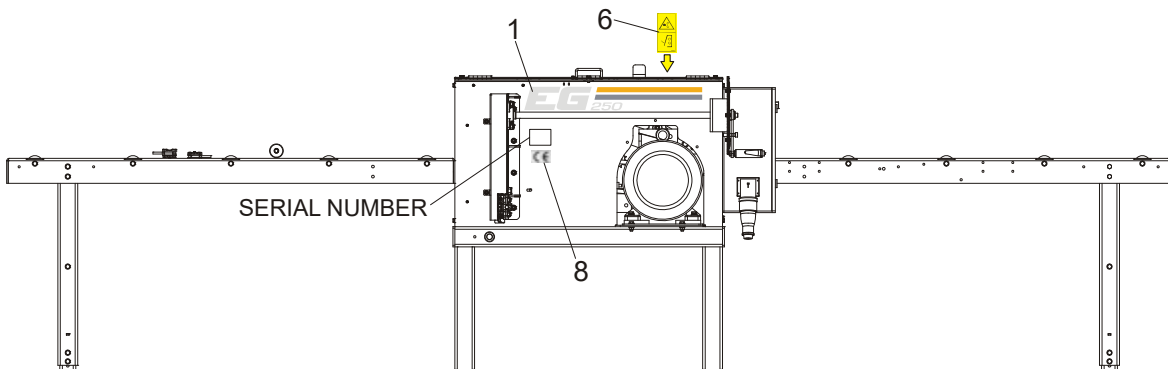
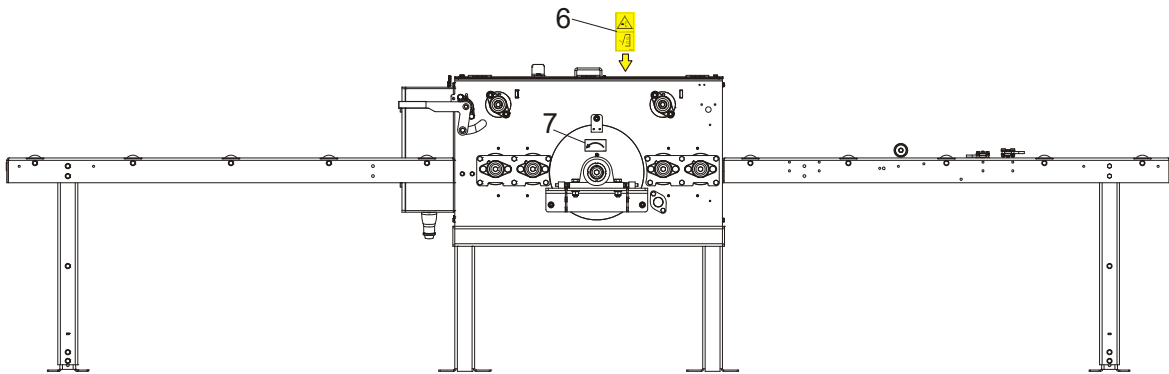

# REPLACEMENT PARTS

## EG250 Edger Decals

8

REF.	DESCRIPTION (◆ Indicates Parts Available In Assemblies Only )	PART #	QTY	
	<b>DECAL KIT, EG250 EDGER</b>	<b>514407</b>	<b>1</b>	
1	DECAL, EG250 EDGER LOGO	514408	1	
2	DECAL, EYE PROTECTION WARNING (PICTOGRAM)	S12004G	2	
3	DECAL, EAR PROTECTION WARNING (PICTOGRAM)	S12005G	2	
4	DECAL, USE SAFETY BOOTS (PICTOGRAM)	501465	2	
5	DECAL, MOTOR DIRECTION	S20097	1	
6	DECAL, SAWMILL COVERS CAUTION	099220	2	
7	DECAL, ROTATION DIRECTION	089296	1	
8	DECAL, CE CERTIFIED MACHINE (SMALL)	P85070	1	
9	DECAL, HIGH VOLTAGE INSIDE THE ELECTRIC BOX (PICTOGRAM)	096316	1	
10	DECAL, REMOVE THE PLUG BEFORE OPENING THE BOX (PICTOGRAM)	096319	1	
11	DECAL, EDGER METRIC SCALE	101007	2	
12	DECAL, READ THE MANUAL BEFORE OPERATING THE MACHINE	096317	1	

## 8.22 Control Box (EG300 - U.S. Only)

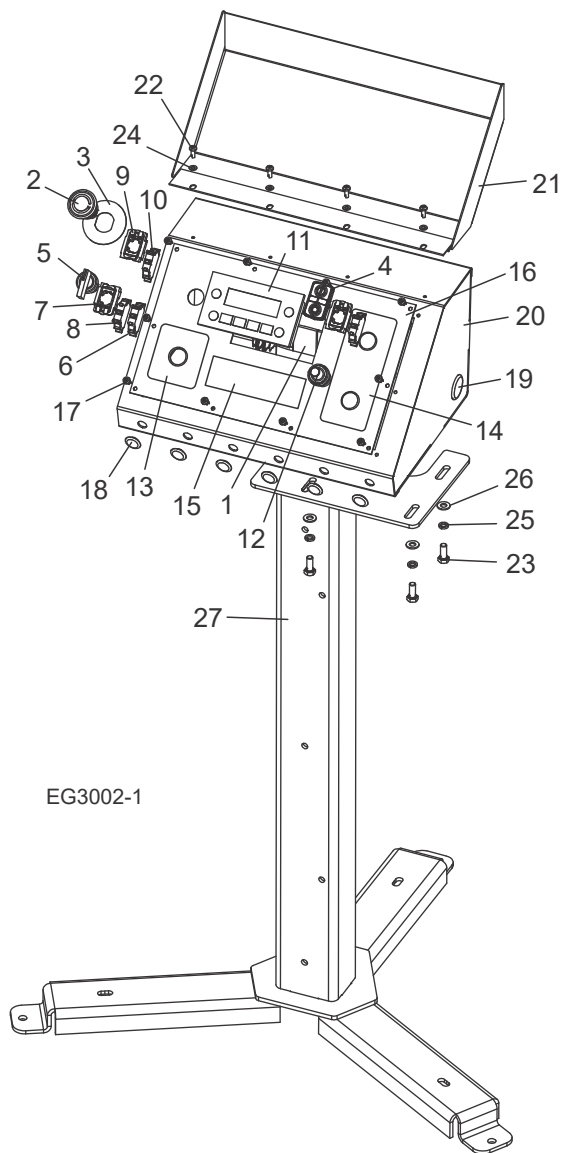

REF.	DESCRIPTION (◆ Indicates Parts Available In Assemblies Only)	PART #	QTY
	<b>OPERATOR ASSEMBLY, EG300EC25U (U.S. ONLY)</b>	068176	1
1	PLC Assembly, PLC Setworks	069849-3	1
	Panel Assembly, EG300U Front Operator	073513	1
2	Push-Button, Mshrm Mntnd Red TrnRI ZB5	068940	1
3	Legend, E-Stop, Round Yellow	050992	1
4	Push-Button, Flush Marked ZB5	068909	1
5	Selector Switch Head, 3 Pos Spring Ret	073511	1
6	Switch Block, NO ZB5	068920	1
	Collar, Mount 1NO ZB5	068952	2
7	Switch Collar, Mount ZB5	068951	1
8	Switch Block, NO ZB5	068920	1
	Switch Collar Assembly, Mount 1NC ZB5	068950	1
9	Switch Collar, Mount ZB5	068951	1
10	Switch Block, Contact NC ZB5	068921	1

11	Display, Text Magelis 4 Line 24VDC Green	069835	1	
12	Switch, Potentiometer 22mm 5k	068077	1	
13	Decal, EG300 Blade In/Out	073514	1	
14	Decal, EG300 On/Off/Feed Rate	073515	1	
15	Decal, EG300 Front Panel Logo	073516	1	
16	Plate, EG300U Front Operator	076133	1	
17	Bolt, #10-24x1/2 Ph Pan Hd, Type 23	F05015-17	10	
18	Plug, 1/2IN Hole	019613	6	
19	Plug, AS050 Oiltite	024685	2	
	Gasket, Control Box	N/A	1	
	Cable Assembly, Edger Modbus Comms	078423	1	
	Cable, 18 Cond 20AWG 600V	R01913-11	15 ft.	
20	<b>CONTROL BOX, TVS</b>	503536-1	1	
21	<b>COVER, LT20/40 CONTROL BOX - COMPLETE</b>	097135-1	1	
22	<b>BOLT, #10-24 X 1/2 PH PAN HEAD TYPE 23</b>	F05015-17	4	
23	<b>BOLT, M8X20-8.8-B-HEX HEAD FULL THREAD ZINC</b>	F81002-4	4	
24	<b>WASHER, 5,3 FLAT ZINC</b>	F81052-1	4	
25	<b>WASHER, 8,4-FLAT ZINC</b>	F81054-1	4	
26	<b>WASHER, 8,2 SPLIT LOCK ZINC</b>	F81054-4	4	
27	<b>STAND, LT20B CONTROL BOX</b>	501651-1	1	

**8.23 Electric Box (EG300 - U.S. Only)**

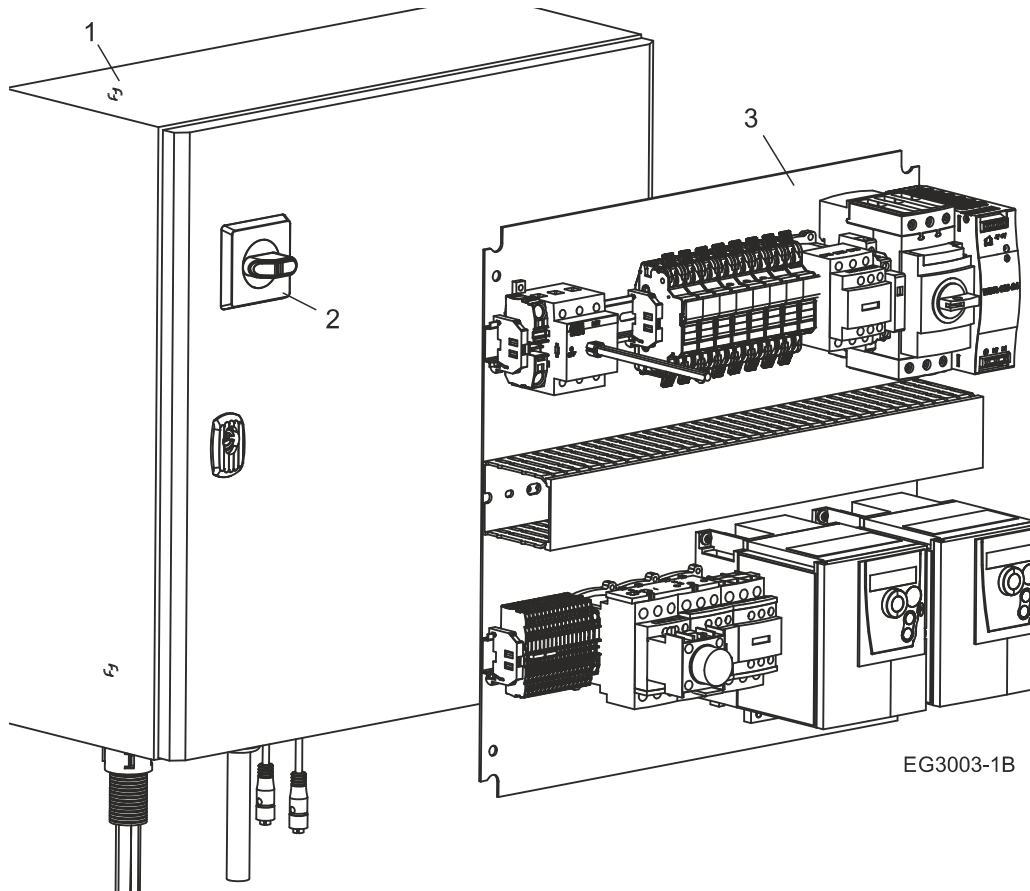

REF.	DESCRIPTION (◆ Indicates Parts Available In Assemblies Only)	PART #	QTY
	<b>EG300 EDGER CONTROL BOX (U.S. ONLY)</b>	068171	1
1	Enclosure, EG300EC25U Control	068090	1
2	Handle, Disconnect RED/YEL 6mm Shaft	050883-1	1
3	Insert Assembly, EG300EC25U Control	073512	1
	<i>See Form #2218 EG300EC25U Electrical Information for Electrical Components and Schematics</i>		



## SECTION 9 DC ELECTROMAGNETIC BRAKE (CE ONLY), SIEMENS MOTORS

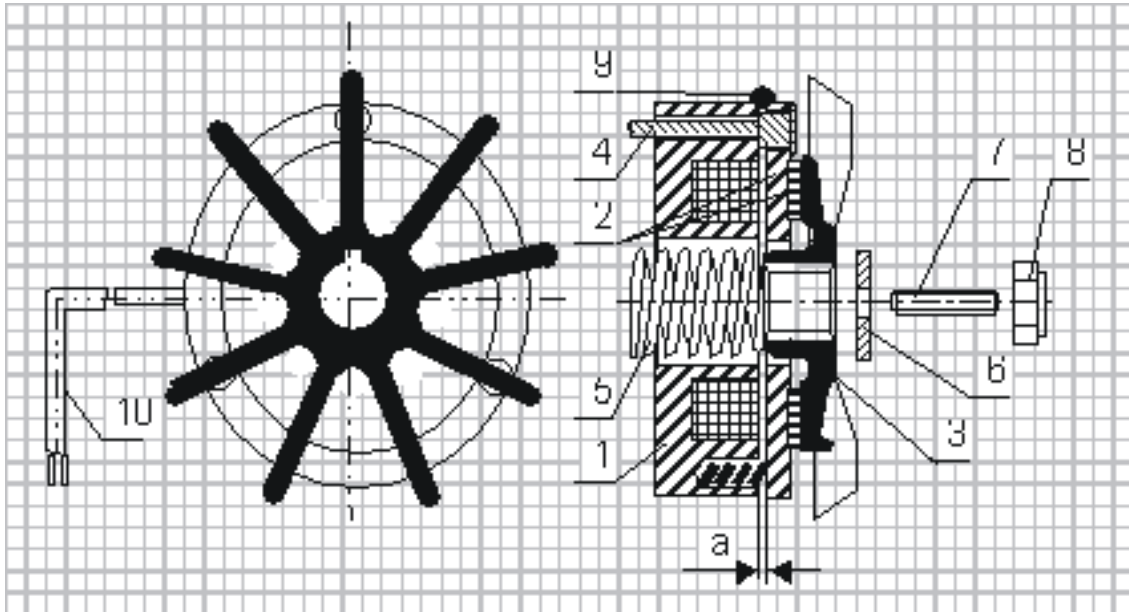

- 1 - Electromagnet,
- 2 - Armature complete with brake linings,
- 3 - Fan,
- 4 - Retaining bolt
- 5 - Central spring,
- 6 - Special washer,
- 7 - Set screw,
- 8 - Self-locking nut,
- 9 - Sealing ring,
- 10 - Output cable.

### 9.1 Design and principle of operation

The DC electromagnetic brake type H consists of 3 main subassemblies:

- electromagnet (1),
- armature complete (2)
- cast iron fan (3).

**Electromagnet (1) energised:** The DC voltage from the motor applied via the rectifying circuit causes the attraction of the armature (2) releasing the brake and thus the fan (3) is free to rotate.

**Electromagnet (1) de-energised:** The electromagnet stops to attract the armature (2) and spring

presses the armature with brake linings (2) against the fan and the brake is thus applied.

## 9.2 Service

During normal operation and at the routine inspections verify the air gap and check if all screws are tight. In case when any symptoms of inefficient braking are observed, then use the self-locking nut (8) to re-adjust the air gap to the value corresponding to Table 1.

Such readjustment may be repeated until the brake linings are completely worn out. When this will occur, a complete armature with brake linings (2) must be replaced.

If the air gap of the brake is correctly adjusted and despite of it the brake does not operate properly (the brake fails to release), it may be caused by:

- the electromagnet (1): burned coil or defected output cable (10),
- rectifying circuit (installed in the electric motor terminal box).

The above mentioned subassemblies should be checked and defected part replaced.

**Table 1:**

TYPE	H-63	H-71	H-80	H-90	H-100	H-112	H-132	H-160
Nominal Gap „a”	0.2 ±0,05	<b>0.2</b> ±0,05	<b>0.2</b> ±0,05	<b>0.2</b> ±0,05	<b>0.2</b> ±0,1	<b>0.2</b> ±0,1	<b>0.2</b> ±0,1	<b>0.2</b> ±0,1

## SECTION 10 BRAKE AIR GAP ADJUSTMENT, TAMEL MOTORS

To ensure proper operation of the brake, it is necessary to set correctly the air gap between the armature plate and the electromagnet. Each time the brake is installed or the motor overheats or the brake is inspected (**the inspection should be performed at least every six months**), check and, if necessary, adjust the brake air gap.

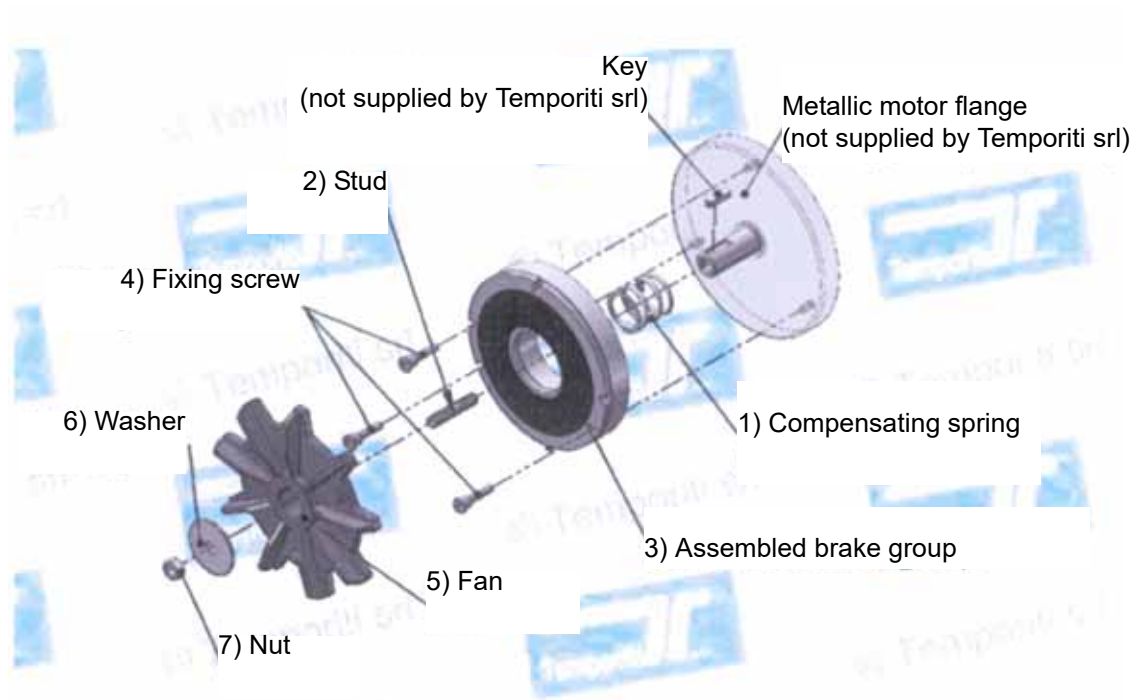

Adjustment of the brake air gap is performed when the gap has reached the value of 0,5mm and always after dismantling the brake.

**To adjust the air gap, perform the following steps :**

- Position the blade of the thickness gauge in the nearness of the fixing screws, between the magnet and the armature plate, as in the picture below, leaving it inserted for all adjusting.

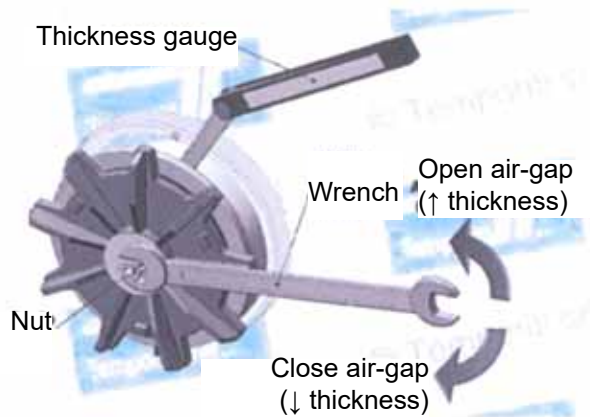

- Adjust the thickness between the air gap according to the values in table 1, fix the hexagonal self-locking nuts previously positioned by screwing/unscrewing with the hexagonal key.
- Check the correct value of the air gap with a thickness gauge blade of 0,1 mm bigger then the thickness used in the previous point and check it does not enter.

Table 1

Air Gap	Value
Minimal	0.20 mm
Maximal	0.50 mm

---

## SECTION 6 LASER INFORMATION

## LP-520L-10

Industrial hermetic focusable laser line generator with rectilinearity correction.

Laser for industrial applications.

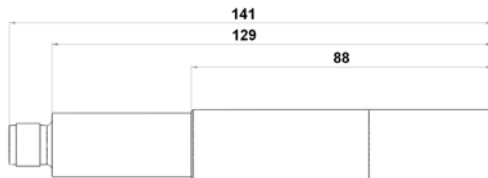

### Technical data:

- Safety Class 2M from EN 60825-1:2014;
- Wavelength  $\lambda=520\text{nm}$ ;
- Average Output Power 10mW;
- Operating Voltage 9V÷28VDC;
- Operating Current <100mA;
- Optics: aspherical acrylic lens F=8mm; NA=0,28; rod lens  $\phi 5$ ;
- Line generating angle  $\sim 90^\circ$  ;
- Possibility to adjust the focus from few cm to several meters (external focus mechanism);
- Dimensions  $\phi 20 \times 130$ ;
- International Protection Rating IP65;
- Aluminium housing (black anodized);
- Chromed brass mounting M18 x 1;
- Operating temperature: 0 do +60°C;
- Storage temperature: -40 do +85°C;
- Laser diode electrically isolated from housing;
- M12 plug, 4-pin M12 x 1;
- Pin configuration:
  - 1: voltage supply (+)
  - 3: voltage supply (-)

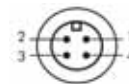

### OPTIONS:

- different optical power, wavelength, line generating angle, gaussian or uniform line optics,
- modulation.



RAIFFEISEN BANK POLSKA S.A.  
 PLN 96 1750 0009 0000 0000 0272 8238, EUR 15 1750 0009 0000 0000 0272 8338  
 USD 55 1750 0009 0000 0000 0272 8297, CHF 90 1750 0009 0000 0000 0272 8348  
 NIP PL5280303208, D&B 422320739

## EC declaration of conformity according to EC Machinery Directive 2006/42/EC, Annex II, 1.A

We herewith declare,

Wood-Mizer Industries sp. z o.o.  
114 Nagorna street, 62-600 Kolo; Poland.

That the following described machine in our delivered version complies with the appropriate basic safety and health requirements of the EC Machinery Directive 2006/42/EC based on its design and type, as brought into circulation by us. In case of alteration of the machine, not agreed by us, this declaration is no longer valid.

Designation of the machine:	<b>Edger Multirip</b>
TYPE:	EG250, EG250-MR, EG250-EMR EG300, EG300-MR, EG300-EMR
No. of manufacturer:	.....
Applicable EC Directives:	EC Machinery Directive 2006/42/EC EC Electromagnetic Compatibility Directive 2004/108/EC
Applicable Harmonized Standards:	PN-EN ISO 12100:2012; PN-EN 1870-4:2012; PN-EN ISO 13849-1:2008 PN-EN 60204-1:2010 PN-EN ISO 13857:2010;
Notified Body according to annex IV :	INSTYTUT TECHNOLOGII DREWNA Centrum Certyfikacji Wyrobów Przemysłu Drzewnego ul. Winiarska 1, 60-654 Poznań
Notification No:	1583
Responsible for:	EC type examination
EC type-examination certificate no.	0415/2014
Responsible for Technical Documentation:	Adam Kubiak / R&D Manager Wood-Mizer Industries Sp. z o.o. 62-600 Koło, ul. Nagórna 114, Poland Tel. +48 63 26 26 000
Place/Date/Authorized Signature:	Koło, 24.10.2014 <b>Adam Kubiak</b>
Title:	R&D Manager