

Wood-Mizer[®] Sawmill

Safety, Setup, Operation & Maintenance Manual

LX150

rev. A2.01



Safety is our #1 concern! Read and understand all safety information and instructions before operating, setting up or maintaining this machine.

Form #2272

California
Proposition 65 Warning



WARNING: Breathing gas/diesel engine exhaust exposes you to chemicals known to the State of California to cause cancer and birth defects or other reproductive harm.

Always start and operate the engine in a well-ventilated area.
If in an enclosed area, vent the exhaust to the outside.
Do not modify or tamper with the exhaust system.
Do not idle the engine except as necessary.

For more information go to **www.P65warnings.ca.gov**.



WARNING: Drilling, sawing, sanding or machining wood products can expose you to wood dust, a substance known to the State of California to cause cancer. Avoid inhaling wood dust or use a dust mask or other safeguards for personal protection.

For more information go to **www.P65Warnings.ca.gov/wood**.

Active Patents assigned to Wood-Mizer, LLC

Wood-Mizer, LLC has received patents that protect our inventions which are a result of a dedication to research, innovation, development, and design. Learn more at: woodmizer.com/patents

©2020 Wood-Mizer LLC

Printed in the United States of America, all rights reserved. No part of this manual may be reproduced in any form by any photographic, electronic, mechanical or other means or used in any information storage and retrieval system without written permission from

Wood-Mizer, LLC
8180 West 10th Street
Indianapolis, Indiana 46214

Table of Contents

Section-Page

SECTION 1	INTRODUCTION	1-1
1.1	About This Manual.....	1-1
1.2	Getting Service.....	1-1
	<i>General Contact Information</i>	1-1
1.3	Warranty.....	1-2
1.4	Customer and Sawmill Identification.....	1-5
1.5	Specifications.....	1-6
	<i>LX150 Dimensions</i>	1-7
SECTION 2	SAFETY	2-5
2.1	Safety Symbols.....	2-5
2.2	Safety Instructions.....	2-5
2.3	Electrical Lockout Procedures.....	2-10
SECTION 3	SAWMILL ASSEMBLY	3-1
3.1	Tools required.....	3-1
3.2	Uncrating the mill.....	3-2
	<i>Pre-assemble the legs</i>	3-6
	<i>Unpack the saw head</i>	3-7
	<i>Assemble the log bed</i>	3-8
3.3	Bumper Assemblies.....	3-10
	<i>Install Travel Locks</i>	3-11
	<i>Leveling the bed</i>	3-12
3.4	Saw Mast Assembly.....	3-13
3.5	Feed Drive Rope Assembly.....	3-15
3.6	Install the Blade.....	3-17
SECTION 4	SAWMILL SETUP	4-1
4.1	Installing the Blade.....	4-1
4.2	Tensioning The Blade.....	4-3
4.3	Tracking The Blade.....	4-3
4.4	Sawblade.....	4-6
	<i>Blade Guide Vertical Tilt Alignment</i>	4-6
	<i>Blade Guide Flange Spacing</i>	4-7
4.5	Starting The Engine.....	4-9
SECTION 5	SAWMILL OPERATION	5-1
5.1	Power Feed.....	5-1
5.2	Up/Down Operation.....	5-3
5.3	Loading, Turning, & Clamping Logs.....	5-4
5.4	Blade Guide Arm Operation.....	5-6
5.5	Cutting The Log.....	5-7
5.6	Edging.....	5-8

Table of Contents

Section-Page

5.7	Blade Height Scale	5-9	
5.8	Water Lube Operation	5-10	
5.9	Transporting the Sawmill	5-11	
SECTION 6	MAINTENANCE		6-1
6.1	Wear Life.....	6-1	
6.2	Blade Guides	6-1	
6.3	Changing The Blade	6-2	
6.4	Sawdust Removal	6-3	
6.5	Mast Track, Wipers, & Scrapers	6-4	
6.6	Vertical Mast Rails	6-5	
6.7	Miscellaneous	6-5	
6.8	Drive Belt Adjustment.....	6-6	
6.9	Up/Down System.....	6-8	
6.10	Charging The Battery	6-9	
SECTION 7	TROUBLESHOOTING GUIDE		7-1
7.1	Sawing Problems	7-1	
SECTION 8	SAWMILL ALIGNMENT		8-1
8.1	Routine Alignment Procedure	8-1	
	<i>Prepare the sawmill for alignment.....</i>	8-1	
	<i>Blade Guide Arm Alignment</i>	8-2	
	<i>Blade Guide Vertical Tilt Alignment.....</i>	8-5	
	<i>Blade Guide Horizontal Tilt Adjustment.....</i>	8-6	
	<i>Blade Guide Flange Spacing</i>	8-7	
	<i>Blade Height Scale Adjustment.....</i>	8-9	
8.2	Complete Alignment Procedure	8-10	
	<i>Frame Setup</i>	8-10	
	<i>Complete Blade Replacement</i>	8-10	
	<i>Blade Wheel Alignment</i>	8-11	
	<i>Blade Guide Re-installation.....</i>	8-14	
	<i>Blade Guide Arm Alignment</i>	8-15	
	<i>Blade Guide Deflection</i>	8-17	
	<i>Blade Guide Vertical Tilt Alignment.....</i>	8-18	
	<i>Blade Guide Flange Spacing</i>	8-20	
	<i>Blade Height Scale Adjustment.....</i>	8-21	
	INDEX		I

SECTION 1 INTRODUCTION

1.1 About This Manual

This manual replaces any previous information received on your Wood-Mizer^{®1} equipment.

The information and instructions in this manual do not amend or extend the limited warranties for the equipment given at the time of purchase.

1.2 Getting Service

General Contact Information

Toll free phone numbers are listed below for the *continental* U.S. and Canada.

	United States	Canada
Sales	1-800-553-0182	1-877-866-0667
Service	1-800-525-8100	1-877-866-0667
Website	www.woodmizer.com	www.woodmizer.ca
E-mail	woodmizer@woodmizer.com	oninfo@woodmizer.com

Office Hours: All times are Eastern Standard Time.

Monday - Friday	Saturday (Indianapolis Office Only)	Sunday
8 a.m. to 5 p.m.	8 a.m. to 12 p.m.	Closed

Please have your customer and serial number ready when you call.

Wood-Mizer will accept these methods of payment:

- Visa, Mastercard, or Discover
- COD
- Prepayment
- Net 15 (with approved credit)

Shipping and handling charges based on size and quantity of order may apply. Items normally ship on the day they are ordered. Next Day or Second Day shipping is available at additional cost.

¹Wood-Mizer[®] is a registered trademark of Wood-Mizer LLC.
U.S. Patent No. 6,655,429.

If your sawmill was purchased outside the United States or Canada, contact your distributor for service.

USA and World Headquarters	Canadian Headquarters
<p><i>Serving North & South America, Oceania, East Asia</i></p> <p>Wood-Mizer LLC 8180 West 10th Street Indianapolis, IN 46214</p> <p>Phone: 317.271.1542 or 800.553.0182 Customer Service: 800.525.8100 Email: infocenter@woodmizer.com</p>	<p><i>Serving Canada</i></p> <p>Wood-Mizer Canada 396 County Road 36, Unit B Lindsay, ON K9V 4R3</p> <p>Phone: 705.878.5255 or 877.357.3373 Fax: 705.878.5355 Email: ContactCanada@woodmizer.com</p>
European, African, and Asian Headquarters	Branches and Authorized Sales Centers
<p><i>Serving Europe, Africa, Western Asia</i></p> <p>Wood-Mizer Industries Sp z o.o. Nagorna 114 62-600 Kolo, Poland</p> <p>Phone: +48.63.26.26.000 Fax: +48.63.27.22.327</p>	<p>For a complete list of dealers, visit www.woodmizer.com</p>

1.3 Warranty

Wood-Mizer® LLC Limited Product Warranty

Wood-Mizer®

Wood-Mizer LLC (“Warrantor”), an Indiana corporation with its principal place of business at 8180 West Tenth Street, Indianapolis, IN 46214-2400 USA, warrants to the purchaser (“Purchaser”) that for the time periods specifically stated herein and subject to the terms, conditions and limitations stated herein, the equipment manufactured by the Warrantor will be free from defects in material and workmanship attributable to Warrantor so long as, during the warranty periods stated herein, the equipment is installed, operated and maintained in accordance with the instructions provided by Warrantor.

PRODUCT	MODEL CLASS	LENGTH OF WARRANTY		EFFECTIVE DATE
		USA & CANADA	NON USA & CANADA	
Portable Sawmills, Resaws, Edgers	LT, LX, HR, EG	Two years	One year	Date of purchase
Portable Sawmills with Chassis	LT28, LT35, LT40, LT50, LT70, LX450	Two years, excluding the chassis, which chassis shall have a five year warranty	One year	

Industrial Sawmills, Resaws, Edgers	WM, HR, EG, TVS, SVS	One year	One year	Date of purchase or date of installation / training (if applicable), whichever occurs first, not to exceed 6 months from date of purchase
TITAN Industrial	WB, TV, HR, EG, EA, MR	One year	One year	
Material Handling	TWC, IC, TD, LD, GC, CR, CB, CC	One year	One year	
Blade Maintenance Equipment	BMS, BMT, BMST	One year	One year	Date of purchase
Options and Accessories	Various	One year*	One year*	
Moulders, Extractors, Kilns	MP, MD, KS, KD	One year	One year	
Slab Flattener	MB	Two years	One year	
Pallet Equipment	PD, PC	One year	One year	
Log Splitters	FS	One year	One year	
Replacement Parts	Various	90 days	90 days	

* Warranty on Options will match the warranty on the primary equipment when purchased on same invoice.

EXCLUSIONS FROM 90 DAY, LIMITED ONE YEAR AND TWO YEAR WARRANTY

Warrantor shall have **no** responsibility under this warranty for any wear components, including, but not limited to: belts, blade guides, blades, electric motor brushes, drum switches, filters, fuses, hoses, bearings (excluding cylindrical drive bearings), bushings, cable carriers, and spark plugs. All wear components are furnished “as is”, without any warranty from Warrantor. This limited warranty does not cover any defects caused by misuse, negligence, alterations, damage due to overload, abnormal conditions, excessive operation, accident, or lack of performance of normal maintenance services.

Several components which are used in the manufacture of the equipment but not manufactured by Warrantor such as cant hooks, power plants, laser sights, batteries, tires, and trailer axles have warranties provided by the original equipment manufacturer (written copies available upon request). Warrantor does not separately warrant such items. Components or equipment manufactured by third parties are not covered by this warranty. Warrantor, however, will provide reasonable assistance to the Purchaser to make claims against any warranties applicable to such component parts as provided by such original equipment manufacturers. Components or equipment manufactured by third parties are not covered by this Warranty.

FIVE YEAR LIMITED CHASSIS WARRANTY

The limited five year chassis warranty described above, DOES NOT extend to (a) any damage stemming from accident, improper towing, overload, abuse, misuse, abnormal conditions, negligence, excessive operation, or lack of maintenance, (b) rust caused by exposure to corrosive atmospheric conditions, or (c) the sawmill head, carriage, axle, brakes, or any hydraulic or electrical components attached to the chassis.

WARRANTOR’S OBLIGATIONS AS TO DEFECTS

In the event that the equipment fails to perform due to defective materials or workmanship attributable to Warrantor under normal use and service within the established warranty period, Purchaser’s sole and exclusive remedy and Warrantor’s sole liability shall be to replace or repair, in Warrantor’s sole and subjective discretion, any defective part at Warrantor’s principal place of business without cost to the Purchaser if such defect exists. The determination of whether a product is defective shall be made by Warrantor in Warrantor’s sole and subjective discretion. The Purchaser must notify Warrantor prior to shipping any defective part. Warrantor, at its sole discretion, may cover expenses incurred in shipping the defective part to Warrantor for evaluation; provided, however, that Warrantor will not be responsible for labor, travel time, mileage, removal, installation or incidental or consequential damages. However, any

part in excess of 140 pounds must be returned by the Purchaser, to the Warrantor's nearest authorized facility at the Purchaser's expense, if return is requested by Warrantor. Warrantor shall have a reasonable time within which to replace or repair the defective part. If Warrantor determines that the product is not defective under the terms of this warranty in Warrantor's sole and subjective discretion, then Purchaser shall be responsible for any expenses incurred by Warrantor in returning the equipment to the Purchaser.

LIMITATIONS AND DISCLAIMERS OF OTHER WARRANTIES

EXCEPT FOR THE EXPRESS WARRANTY PROVISIONS STATED ABOVE, WARRANTOR DISCLAIMS ALL WARRANTIES, EXPRESS AND/OR IMPLIED, INCLUDING WITHOUT LIMITATION, THE IMPLIED WARRANTIES OF MERCHANTABILITY, AND FITNESS FOR A PARTICULAR PURPOSE, NONINFRINGEMENT AND TITLE. No representation or other affirmation of fact by representatives of Warrantor, whether verbal or in writing, including photographs, brochures, samples, models, or other sales aids, shall constitute a warranty or other basis for any legal action against Warrantor. There are no other representations, promises, agreements, covenants, warranties, guarantees, stipulations or conditions, express or implied, by Warrantor except as expressly set forth herein. THE ORIGINAL PURCHASER AND ANY INTENDED USER OR BENEFICIARY OF THIS EQUIPMENT, SHALL NOT BE ENTITLED TO RECOVER ANY INDIRECT, SPECIAL, PUNITIVE, EXEMPLARY, CONSEQUENTIAL, SPECIAL, OR INCIDENTAL DAMAGES OR LOSSES, INCLUDING BUT NOT LIMITED TO, DAMAGES OF LOST PRODUCTION, LOST REVENUE, LOST PRODUCT, LOST PROFITS, LOST BUSINESS, LOSS OF USE, LOSS OF GOODWILL, OR BUSINESS INTERRUPTION, FROM WARRANTOR FOR ANY REASON WHATSOEVER INCLUDING WITHOUT LIMITATION WARRANTY OR DEFECT IN THE PRODUCT REGARDLESS OF THE SOLE, JOINT AND/OR CONCURRENT NEGLIGENCE, BREACH OF CONTRACT, BREACH OF WARRANTY, STRICT LIABILITY IN TORT OR STATUTORY CLAIMS OR OTHER LEGAL FAULT OR RESPONSIBILITY OF EITHER WARRANTOR OR PURCHASER OR ITS EMPLOYEES OR AGENTS. Warrantor does not warrant that its equipment meets or complies with the requirements of any particular safety code or governmental requirements.

Defective items replaced under the terms of this warranty become the property of Warrantor.

DESIGN CHANGES

Warrantor reserves the right to change the design of its products from time to time without notice and without obligation to make corresponding changes in or to its products previously manufactured.

RIGHTS OF PURCHASERS

The validity and effect of this limited warranty as well as its interpretation, operation and effect, shall be determined exclusively by the principles of law and equity of the State of Indiana, USA. This limited warranty gives Purchaser specific legal rights. Purchaser may also have other rights, which may vary from state to state. Some states may not allow limitations as to the duration of implied warranties or to the exclusion or limitation of incidental or consequential damages, so some of the limitations and exclusions detailed set forth above may not apply. In the event that any one or more of the provisions of this warranty shall be or become invalid, illegal or unenforceable in any respect, the validity, legality and enforceability of the remaining provisions of this warranty shall not be affected thereby.

INTERPRETATIONS

This Warranty constitutes the entire warranty agreement between Warrantor and Purchaser and supersedes any prior understandings or agreements pertaining to the same subject matter. This warranty cannot be amended except in writing which refers to this warranty which is signed by both Warrantor and Purchaser.

© 2020 Wood-Mizer LLC – 8180 West 10th Street, Indianapolis, IN 46214

1.4 Customer and Sawmill Identification

Each Wood-Mizer sawmill is identified with a model number, revision, and serial number (see the figure below).

MFG BY/FABRIQUÉ PAR: WOOD-MIZER PRODUCTS, INC. 8180 W. 10th St. Indianapolis,
46214-2400 U.S.A. 317/271-1542 Or 800/553-0182

Model No.: LX150

Serial No.: 01190001	Rev.: A1.00
-----------------------------	--------------------

Sawmill U.S. Patent Nos. 3,935,780 and 4,559,858; Brevet au Canada 1986 No. 1,211,684 Brevete 1986;
Dry Kiln U.S. Patent Nos. 4,620,373 et 4,490,926. Other patents pending.

SERIAL NUMBER TAG.

The model number includes the base model and the engine/motor configuration. The serial number contains the month and year of manufacture and a sequence number. The revision number helps identify the exact design of the equipment.

Model Number	LX150 Basic Sawmill I.D.	G14 Engine/Motor Configuration
Serial Number	0119 Month/Year of Manufacture	0001 Manufacture Sequence
Revision Number	A1. Major Revision Code	00 Minor Revision Code

MODEL, SERIAL, AND REVISION NUMBER DESCRIPTION.

1 Introduction

Specifications

1.5 Specifications

Model: LX150 Rev. A1.00+

Dimensions:

Length: 218.5" 18'-2.5"
Width: 100" 8'-4"
Height (Ground To Mast): 6'-4.75" (not including 4" legs)
Height (Max Head Position): 7'-2" (not including 4" legs)

Weights (Estimated):

G25
Basic Unit :

Log Capacity:

Length: 18' 5"
Log Diameter: 36"
Max Throat Width (guide to guide): 35-1/2"

Engine:

G25
Manufacturer: Kohler
Fuel: Gas
Horsepower Rating: 25
Weight: 151
Idle Speed: 1800 RPM
High Throttle Speed (No Load): 3600 RPM

Noise Level - @ operator position: 102 dBA
Noise Level - 20 feet away: 94 dBA
Blade Speed (No Load):
Fuel Consumption (per hour): 0.9 gal.
Cooling System: Air
Drive Shaft O.D.: 1 1/8"
Drive Pulley O.D.: 5.6"
Drive Belt: 2/3VFL900
Blade Braking: 5 Seconds
Oil Capacity w/Filter: 2.1 qts.
Battery: 12V 524/26A

Rates:

Hourly Production: up to 125 bdf.
(Average range w/experienced operators
and average size logs)

LX150 Dimensions

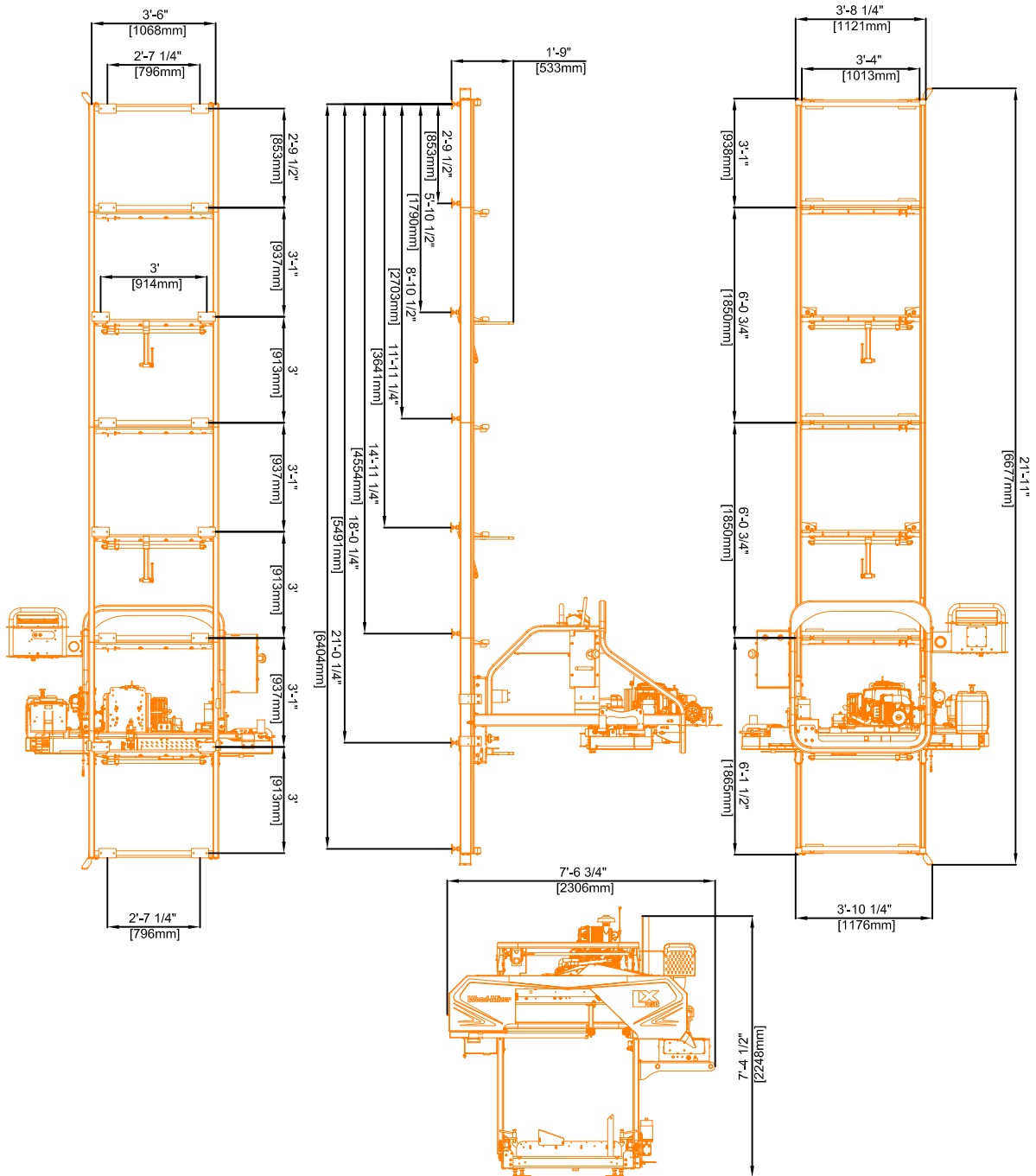

SECTION 2 SAFETY

2.1 Safety Symbols

The following symbols and signal words call your attention to instructions concerning your personal safety. Be sure to observe and follow these instructions.



DANGER! indicates an imminently hazardous situation which, if not avoided, will result in serious injury or death.



WARNING! suggests a potentially hazardous situation which, if not avoided, could result in serious injury or death.



CAUTION! refers to potentially hazardous situations which, if not avoided, may result in minor or moderate injury or damage to equipment.

NOTICE: indicates vital information.

NOTE: gives helpful information.

2.2 Safety Instructions

OWNER'S RESPONSIBILITY

NOTICE: The procedures listed in this manual may not include all ANSI, OSHA, or locally required safety procedures. It is the owner/operator's responsibility and not Wood-Mizer Products to ensure all operators are properly trained and informed of all safety protocols. Owner/Operators are responsible for following all safety procedures when operating and performing maintenance to the Sawmill.

NOTE: ONLY safety instructions regarding personal injury are listed in this section. Caution statements regarding only equipment damage appear where applicable throughout the manual.

OBSERVE SAFETY INSTRUCTIONS

NOTICE: Read the entire Operator's Manual before operating the sawmill. Take notice of all safety warnings throughout this manual and those posted on the machine. Keep this manual with this machine at all times, regardless of ownership.

Also read any additional manufacturer's manuals and observe any applicable safety instructions including dangers, warnings, and cautions.

Only persons who have read and understood the entire operator's manual should operate the sawmill. The sawmill is not intended for use by or around children.

NOTICE: It is always the owner's responsibility to comply with all applicable federal, state and local laws, rules and regulations regarding the ownership, operation and towing of your Wood-Mizer sawmill. All Wood-Mizer mill owners are encouraged to become thoroughly familiar with these applicable laws and comply with them fully while using the mill.



WARNING! Clean sawdust from all guards, vents, control boxes, or any area where sawdust may gather **after every shift**. Failure to do so may result in fire, causing death or serious injury.



WEAR SAFETY CLOTHING



WARNING! Secure all loose clothing and jewelry before operating the sawmill. Failure to follow this may result in serious injury or death.



WARNING! Always wear gloves and eye protection when handling bandsaw blades. Changing blades is safest when done by one person! Keep all other persons away from area when coiling, carrying or changing a blade. Failure to follow this may result in serious injury or death.



WARNING! Always wear eye, ear, and foot protection when operating or servicing the sawmill. Failure to follow this may result in serious injury or death.



WARNING! Some woods require respiration protection when operating the sawmill. It is the sawyer's responsibility to know which woods require respiration protection. Failure to follow this may result in serious injury or death.



KEEP SAWMILL AND AREA AROUND SAWMILL CLEAN



DANGER! Maintain a clean and clear path for all necessary movement around the mill and lumber stacking areas. Failure to follow this will result in serious injury or death.

HANDLE FUEL/LUBRICANTS SAFELY



DANGER! Due to the flammable nature of fuel and oil, never smoke, weld, grind or allow sparks near your engine or storage tanks, especially during times of fueling. Failure to follow this will result in serious injury or death.



DANGER! Never allow fuel to spill on a hot engine. The hot temperature of your engine could induce a fire or explosion. Failure to follow this will result in serious injury or death.



WARNING! Store gasoline away from sawdust and other flammable materials. Failure to follow this may result in serious injury or death.



WARNING! Use ONLY water and Wood-Mizer Lube Additive with the water lube accessory. Never use flammable fuels or liquids such as diesel fuel. If these types of liquids are necessary to clean the blade, remove it and clean with a rag. Failure to follow this can damage the equipment and may result in serious injury or death.



DISPOSE OF SAWING BY-PRODUCTS PROPERLY

NOTICE: Always properly dispose of all sawing by-products, including sawdust and other debris, coolant, oil, fuel, oil filters and fuel filters.

USE CAUTION WHEN WORKING WITH BATTERIES (GAS & DIESEL SAWMILLS ONLY)



DANGER! Batteries expel explosive gases; keep sparks, flames, burning cigarettes, or other ignition sources away at all times. Failure to follow this will result in serious injury or death.



WARNING! Always wear safety goggles and a face shield when working near batteries. Failure to follow this could result in serious injury or death.



WARNING! Wash hands after handling batteries to remove possible lead, acid, or other contaminants. Failure to follow this could result in serious injury or death.



WARNING! Charge the battery in a well ventilated area. Failure to follow this could result in serious injury or death.



WARNING! Do not attempt to charge a frozen battery. Failure to follow this could result in serious injury or death.

NOTICE: When working with batteries, use extreme care to avoid spilling or splashing electrolyte (dilute sulfuric acid) as it can destroy clothing and burn the skin.

EMERGENCY TREATMENT FOR CONTACT WITH BATTERY COMPONENTS (LEAD/SULFURIC ACID) per SDS (Safety Data Sheet):

EYE CONTACT	Sulfuric Acid and Lead: Flush eyes immediately with large amounts of water for at least 15 minutes while lifting lids. Seek immediate medical attention if eyes have been exposed directly to acid.
SKIN CONTACT	Sulfuric Acid: Flush affected area(s) with large amounts of water using deluge emergency shower, if available, shower for at least 15 minutes. Remove contaminated clothing, including shoes. If symptoms persist, seek medical attention. Wash contaminated clothing before reuse. Discard contaminated shoes. Lead: Wash immediately with soap and water.
INGESTION	Sulfuric Acid: Administer large amounts of water. Do NOT induce vomiting or aspiration into the lungs may occur and can cause permanent injury or death; consult physician.
INHALATION	Sulfuric Acid: Remove to fresh air immediately. If not breathing, give artificial respiration. If breathing is difficult, give oxygen. Consult a physician. Lead: Remove from exposure, gargle, wash nose and lips; consult physician.



CAUTION! Do not overcharge the battery. Overcharging may reduce the overall service life of the battery.



CAUTION! Be sure the battery is fully charged before transporting the sawmill. If the battery is not fully charged, excessive vibration could reduce the overall service life of the battery.

CAUTIONS FOR SAWMILL SETUP



WARNING! Do not set up the mill on ground with more than a 10 degree incline. If setup on an incline is necessary, put blocks under one side of the mill or dig out areas for the legs to keep mill level. Setting up the mill on an incline could cause it to tip over. Failure to follow this will result in serious injury or death.



WARNING! Keep all persons out of the area while loading and unloading the sawmill. Failure to follow this may result in serious injury or death.

CHECK SAWMILL BEFORE OPERATION



DANGER! Make sure all guards and covers are in place and secured before operating or towing the sawmill. Failure to follow this will result in serious injury or death.

Be sure the blade housing and pulley covers are in place and secure. Use the safety retainer pin and cable to fasten blade housing covers.



WARNING! Do not operate the sawmill without the retaining (stop bumper) bracket properly installed on the bed. The saw head may tip and fall from the sawmill. Failure to follow this will result in serious injury or death.

KEEP PERSONS AWAY



DANGER! Keep all persons out of the path of moving equipment and logs when operating sawmill or loading and turning logs. Failure to follow this will result in serious injury or death.



WARNING! Always be sure the blade is disengaged and all persons are out of the path of the blade before starting the engine or motor. Failure to follow this may result in serious injury or death.

KEEP HANDS AWAY



DANGER! Always keep hands away from moving bandsaw blade. Failure to follow this will result in serious injury or death.



DANGER! Stay a safe distance from rotating members and make sure that loose clothing or long hair does not engage rotating members resulting in possible injury. Failure to follow this will result in serious injury or death.



WARNING! Always disengage the blade and shut off the sawmill engine before changing the blade. Failure to follow this may result in serious injury or death.



WARNING! Do not touch or perform service functions on a hot engine; allow the engine to cool sufficiently before beginning any service function. Failure to follow this may result in serious injury or death.



WARNING! Do not spin the blade wheels by hand. Failure to follow this may result in serious injury or death.



WARNING! Disengage the clutch/brake mechanism whenever the sawmill is not cutting. Failure to follow this may result in serious injury or death.





WARNING! Do not adjust the engine drive belt with the engine running. Failure to follow this may result in serious injury or death.



 **WARNING!** Keep hands, feet, and other objects away from the sawdust chute when operating sawmill. Failure to follow this may result in serious injury or death.

CAUTIONS FOR GAS OR DIESEL ENGINE OPERATION

 **DANGER!** Operate your engine/machine only in well ventilated areas. Failure to follow this will result in serious injury or death.

 **WARNING!** Never operate an engine with a fuel or oil leak; combustibles may come in contact with hot surfaces and ignite into flames. Failure to follow this may result in serious injury or death.

 **WARNING!** Do not operate engine without proper and operational spark arrester/muffler. Sparks emitted from the engine exhaust could ignite surrounding materials. Failure to follow this may result in serious injury or death.

KEEP SAFETY LABELS IN GOOD CONDITION

NOTICE: Always be sure that all safety decals are clean and readable. Replace all damaged safety decals to prevent personal injury or damage to the equipment. Contact your local distributor, or call your Customer Service Representative to order more decals.

NOTICE: If replacing a component which has a safety decal affixed to it, make sure the new component also has the safety decal affixed.

USE CAUTION WHEN WORKING WITH HEAVY LOGS

 **WARNING!** Always make sure log is clamped securely before sawing. Failure to follow this may result in serious injury or death.

UP/DOWN SYSTEM SAFETY

 **WARNING!** Secure the saw head with a chain rated at least 1900 lbs. working load capacity before adjusting the up/down chain to prevent falls. Failure to follow this may result in serious injury or death.

2.3 Electrical Lockout Procedures

RULES FOR USING LOCKOUT PROCEDURE

The equipment shall be locked out to protect against accidental or inadvertent operation when such operation could cause injury to personnel. Do not attempt to operate any switch or valve bearing a lock.

LOCKOUT PROCEDURES MUST BE USED DURING, BUT NOT LIMITED TO:

Table 1:

Changing or adjusting blades	Electrical maintenance
Unjamming operations	Retrieval of tools/parts from work area
Cleaning	Activities where guards or electrical panel guard is open or removed
Mechanical repair	

MAINTENANCE HAZARDS INCLUDE, BUT NOT LIMITED TO:

Table 2:

Blade contact	Missiles (thrown blades/wood chips)
Pinch points	Electrical
Kickbacks	

FAILURE TO LOCKOUT MAY RESULT IN, BUT NOT LIMITED TO:

Table 3:

Cut	Serious injury and death
Crush	Amputation
Blindness	Burn
Puncture	Shock
Electrocution	

TO CONTROL MAINTENANCE DANGERS:

- Lockout procedures must be followed (see **OSHA regulation 1910.147**).
- Never rely on machine stop control for maintenance safety (emergency stops, on/off buttons, interlocks).
- Do not reach into moving blades or feed systems. Allow all coasting parts to come to a complete stop.
- Electrical power supply and air supply must both be locked out.
- Where established lockout procedures cannot be used (electrical troubleshooting or mechanical dynamic troubleshooting), alternative effective protective techniques shall be employed which may require special skills and planning.
- Always follow safe operations practices in the workplace.

EQUIPMENT LOCKOUT PROCEDURE

Lockout procedures per OSHA regulation 1910.147, appendix A:

GENERAL

The following simple lockout procedure is provided to assist owner/operators in developing their procedures so they meet the requirements of **OSHA regulation 1910.147**. When the energy isolating devices are not lockable, tagout may be used, provided the owner/operator complies with the provisions of the standard which require additional training and more rigorous periodic inspections. When tagout is used and the energy isolating devices are lockable, the owner/operator must provide full operator protection (see OSHA regulation 1910.147, paragraph (c)(3)) and additional training and more rigorous periodic inspections are required. For more complex systems, more comprehensive procedures may need to be developed, documented, and utilized.

PURPOSE

This procedure establishes the minimum requirements for the lockout of energy isolating devices whenever maintenance or servicing is done on machines or equipment. It shall be used to ensure that the machine or equipment is stopped, isolated from all potentially hazardous energy sources and locked out before personnel perform any servicing or maintenance where the unexpected energization or start-up of the machine or equipment or release of stored energy could cause injury.

COMPLIANCE WITH THIS PROGRAM

All personnel are required to comply with the restrictions and limitations imposed upon them during the use of lockout. The authorized personnel are required to perform the lockout in accordance with this procedure. All operators, upon observing a machine or piece of equipment which is locked out to perform servicing or maintenance shall not attempt to start, energize, or use that machine or equipment.

SEQUENCE OF LOCKOUT

1. Notify all affected personnel that servicing or maintenance is required on a machine or equipment and that the machine or equipment must be shut down and locked out to perform the servicing or maintenance.
2. The authorized employee shall refer to the company procedure to identify the type and magnitude of the energy that the machine or equipment utilizes, shall understand the hazards of the energy, and shall know the methods to control the energy.
3. If the machine or equipment is operating, shut it down by the normal stopping procedure (depress the stop button, open switch, close valve, etc.).
4. De-activate the energy isolating device(s) so that the machine or equipment is isolated from the energy source(s).
5. Lock out the energy isolating device(s) with assigned individual lock(s).
6. Stored or residual energy (such as that in capacitors, springs, elevated machine members, rotating flywheels, hydraulic systems, and air, gas, steam, or water pressure, etc.) must be dissipated or restrained by methods such as grounding, repositioning, blocking, bleeding down, etc.
7. Ensure that the equipment is disconnected from the energy source(s) by first checking that no personnel are exposed, then verify the isolation of the equipment by operating the push button or

other normal operating control(s) or by testing to make certain the equipment will not operate.



CAUTION! Return operating control(s) to neutral or "off" position after verifying the isolation of the equipment.

8. The machine or equipment is now locked out.

RESTORING EQUIPMENT TO SERVICE

When the servicing or maintenance is completed and the machine or equipment is ready to return to normal operating condition, the following steps shall be taken.

1. Check the machine or equipment and the immediate area around the machine to ensure that nonessential items have been removed and that the machine or equipment components are operationally intact.
2. Check the work area to ensure that all personnel have been safely positioned or removed from the area.
3. Verify that the controls are in neutral.
4. Remove the lockout devices and re-energize the machine or equipment.

NOTE: The removal of some forms of blocking may require re-energization of the machine before safe removal.

5. Notify affected personnel that the servicing or maintenance is completed and the machine or equipment is ready for use.

PROCEDURE INVOLVING MORE THAN ONE PERSON

In the preceding steps, if more than one individual is required to lock out the equipment, **each shall place his own personal lock on the energy isolating devices.**

SECTION 3 SAWMILL ASSEMBLY

CAREFUL PLANNING IS ESSENTIAL TO A SMOOTH ASSEMBLY.

READ THIS SECTION *THOROUGHLY* TO PLAN THE ASSEMBLY.



IMPORTANT! Do not unbolt all the shipping brackets at once. Remove the shipping brackets securing the sawmill to the pallet at each step to prevent inadvertent shifting of the parts.

3.1 Tools required

Lifting device (fork lift, crane, etc.)

Socket set, metric and imperial

Open-end wrench set, metric and imperial

Socket driver

Utility knife

Rubber mallet

Two blocks, minimum 5-1/2" tall. (Ideal size: 5-1/2 x 5-1/2 x 20")

3.2 Uncrating the mill

See Figure 3-1.



FIG. 3-1

1. Remove any shipping straps or plastic coverings from the mill before beginning.
2. Remove and inspect the parts boxes. (See Table 1.)

NOTE: If the saw head blocks the parts boxes, the head can be raised using the operator's control. The battery is connected at the factory, so power is available to raise the head. See [See Section 5.2 Up/Down Operation](#).

3. Leave the blade in its box.

TABLE 1: PARTS BOX CONTENTS

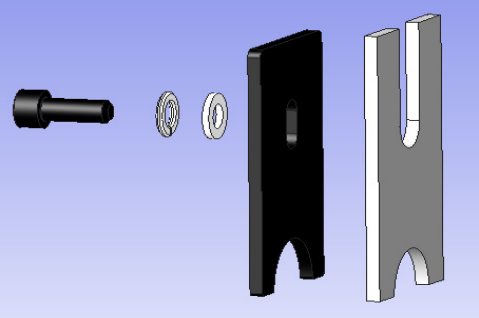
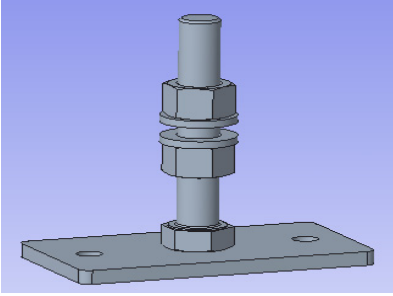
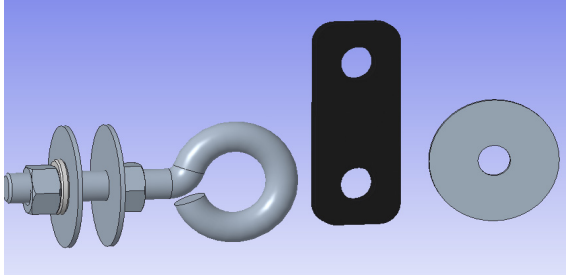
Part #	Description	Qty	Image
Rail Wiper Assemblies			
517609	Wiper	4	
517610-1	Wiper Plate	4	
F05020-6	Bolt, M6-1x20 HH Class 8	4	
F05026-2	Washer, M6 Split Lock	4	
F05026-1	Washer, M6 Flat Class 4	4	
Bed Feet Assembly			
F81037-1	Nut, M20-8 Hex Zinc	32	
F81059-2	Washer, 21 Flat Zinc	32	
514996-1	Leg, Weldment	16	
Power Feed Rope Assembly			
049339	Plate, Rope Lock	1	
F05011-44	Washer, 3/8 Fender	3	
F05011-4	Washer, 3/8 Split Lock	1	
F01010-1	Nut, 3/8-16 Hex	2	
F05007-30	Bolt, 3/8-16x2 Eye 5/8 ID	1	
018035	Rope, 5/16Dia Solid Braided Poly 36ft (Not shown)	1	



3 Sawmill Assembly

Uncrating the mill

TABLE 1: PARTS BOX CONTENTS

Part #	Description	Qty	Image
	Idle Side Bed Stop Assembly, Front Back Orientation		
516075-1	Plate, Bed Stop	2	
515061-1	Plate, Bed Stop Shim	2	
P12165	Bushing, Bed Stop	2	
086182-1	Bolt, Bed Stop	2	
F81043-2	Pin, Roll S-Zn 4x25 PN-M/82001	2	
F81055-1	Washer, Flat 10,5 Fe/Zn5 PN-78/M-82005	8	
F81033-1	Nut, M10-8-B -Fe/Zn PN-M82175	4	
F81003-17	Bolt, M10x35-8.8 Fe/Zn5 PN-M/82105	4	
	Power Feed Side Bed Stop Assembly, Front Back Orientation		
517901-1	Plate, Bed Stop (Front)	1	
517902-1	Plate, Bed Stop (Rear)	1	
515061-1	Plate, Bed Stop Shim	2	
P12165	Bushing, Bed Stop	2	
086182-1	Bolt, Bed Stop	2	
F81043-2	Pin, Roll S-Zn 4x25 PN-M/82001	2	
F81055-1	Washer, Flat 10,5 Fe/Zn5 PN-78/M-82005	8	
F81033-1	Nut, M10-8-B -Fe/Zn PN-M82175	4	
F81003-17	Bolt, M10x35-8.8 Fe/Zn5 PN-M/82105	4	

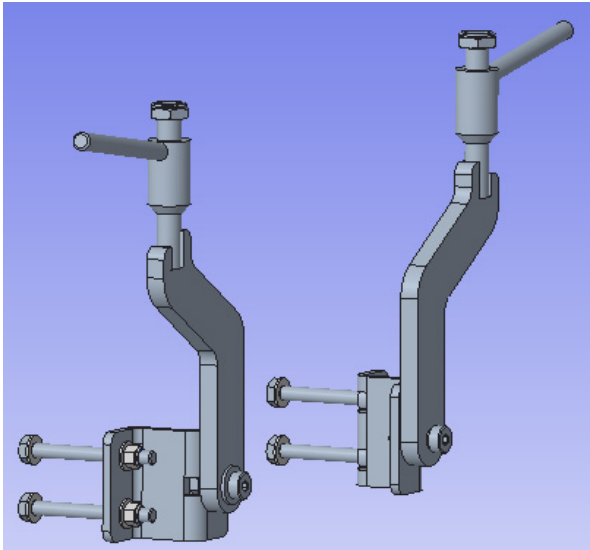
TABLE 1: PARTS BOX CONTENTS

Part #	Description	Qty	Image
	Travel Locks (Left and Right)		
110778	Bracket, Travel Lock Mount	2	
079600	Lock Weldment, Travel	2	
079747	Nut Weldment, Travel Lock	2	
F05010-10 1	Nut, 5/8-18 Nyl Jam	2	
F05011-2	Washer, 1/2 SAE Flat	2	
F05008-11 5	Bolt, 1/2x5/8 Shoulder 3/8-16 Thrd Unplated	2	
F05010-25	Nut, 3/8-16 Swaged	2	
F05011-13 4	Washer, M10 Flat	8	
F05022-22	Bolt, M10-1.5x90 Hex Head Class 8	4	
F05004-27 0	Nut, M10-1.50 Hex Nyl Lock	4	
	Mast Safety Assemblies	3	
011119	Plate, LX150 Mast Safety	3	
P13576	Pad, Catapillar Track	3	
F05021-2	Bolt, M8-1.25x20 Class 8 HH	6	
507563	Bolt, Clamp Complete	2	

3 Sawmill Assembly

Pre-assemble the legs

TABLE 1: PARTS BOX CONTENTS

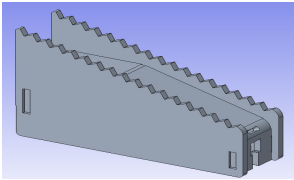
Part #	Description	Qty	Image
515413-1	Wedge	1	

- 4. Open the parts box and spread the parts out in an orderly fashion. See Figure 3-2.
- See Figure 3-2.**

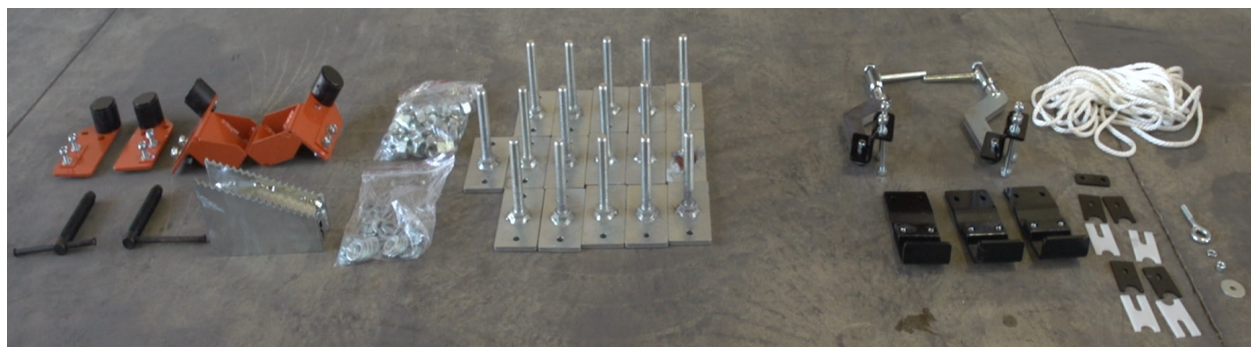

FIG. 3-2

- 5. Ensure all the parts are present.

Pre-assemble the legs

- 1. Place one F81037-1 nut and F81059-2 washer on all 16 bed feet.
- 2. Spin the nuts uniformly down each foot, approximately 1/2 to 2/3 of the way.

See Figure 3-3.

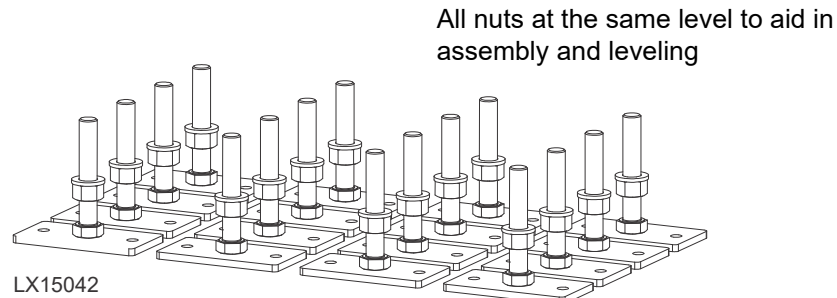
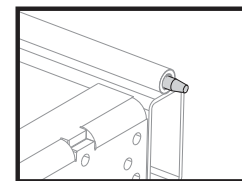

FIG. 3-3

3. Place the small bed section at the end of the designated area for the mill assembly.



IMPORTANT! Observe the direction of the alignment pins in relation to the remaining bed sections. Plan the assembly such that the log supports are on the same side as the operator's station.



NOTE: Ensure the bed is assembled in the final operating location. Once assembled, it should not be moved.

Unpack the saw head

1. Ensure all shipping restraints are removed prior to performing the next step.
2. Prepare a location for the mast to set down on blocks similar to the shipping blocks (ideal size: 5-1/2 x 5-1/2 x 20") prior to removing it from the transport crate.



WARNING! Use a fork lift, crane, or other lifting device to remove the saw head from the packing crate. Failure to follow this may result in serious injury or death.

3. Securely attach lifting straps to the top of the mast as shown in Figure 3-4.



CAUTION! Set the mast down **ONLY** on the prepared blocks. Setting it on any other surface may result in major equipment damage.

3 Sawmill Assembly

Assemble the log bed

See Figure 3-4.

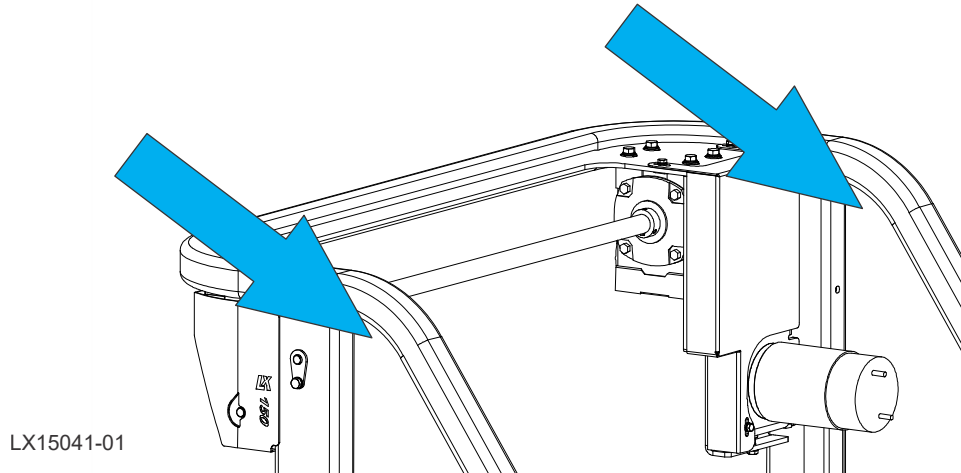

FIG. 3-4

Assemble the log bed



WARNING! Use a minimum of two people to remove the bed sections from the packing crate. Failure to follow this may result in serious injury.



1. Unbolt the next bed section from the shipping strap and remove. (**Do not unbolt all the sections at once to prevent inadvertent movement.**)
2. Apply the bed legs to the sections as shown in Figure 3-5.

See Figure 3-5.

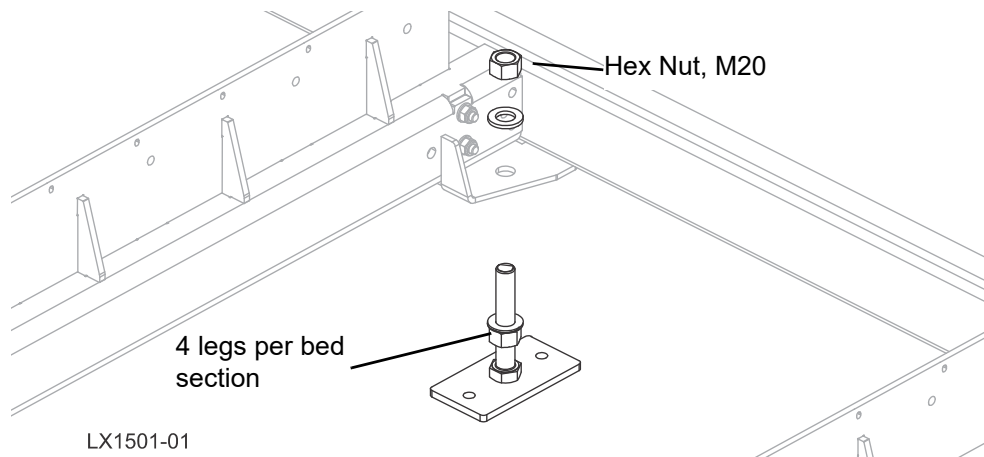

FIG. 3-5

3. Lay the first and second bed sections end-to-end so the track alignment pins of each section align with the section in front of it.
4. Slide the sections together as shown in Figure 3-6.

See Figure 3-6.

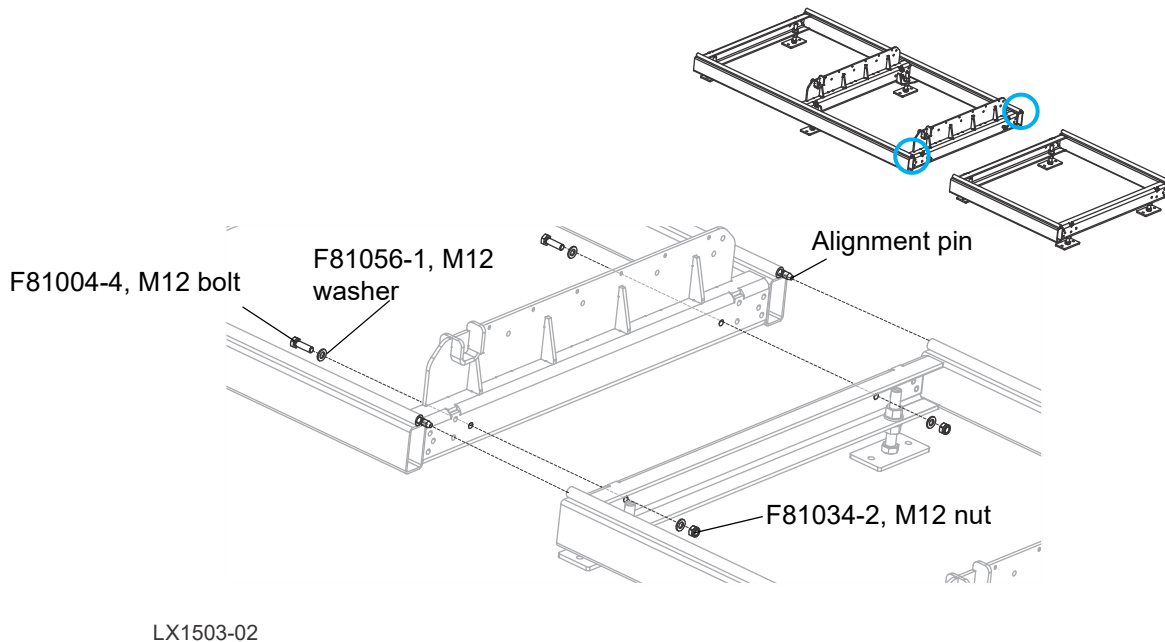

FIG. 3-6

5. Use a rubber hammer to force the alignment pins into bed rails, if necessary.
6. Secure the bed sections together as shown in Figure 3-6, drawing the top surface together smoothly.

NOTE: The top surface (round rails) touch before the square support tubes, leaving a small (1/8" +/-) gap. This is normal. Do not attempt to draw the square support tubes together.

NOTE: Make sure the top surfaces (round rails) of the bed sections are smoothly aligned. It may be necessary to adjust one bed section up or down until the surfaces are aligned, then tighten the bolts.

7. Recheck that the rail joints are tight and smooth.
8. Level the bed and readjust legs as necessary.

See Figure 3-7.

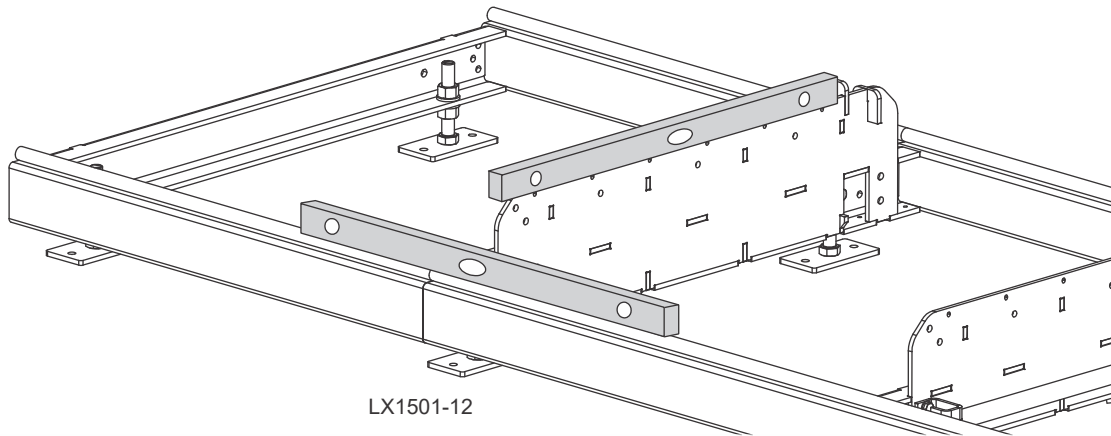

FIG. 3-7

9. Loosen the upper nut on the feet, then use lower nut to adjust the sawmill bed height; retighten the upper nut.

See Figure 3-8.

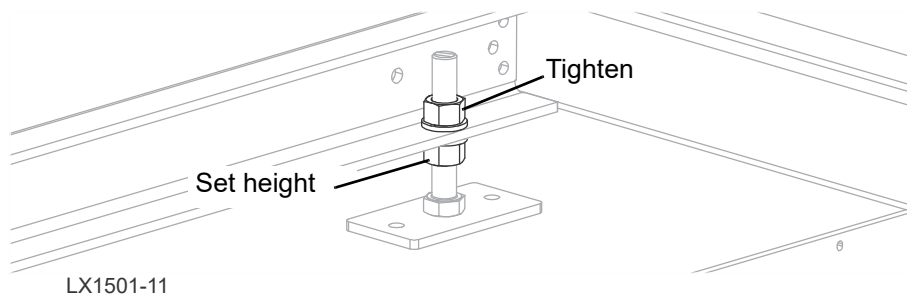

FIG. 3-8

10. Repeat this procedure for the third and fourth bed section.

3.3 Bumper Assemblies



IMPORTANT! The bumpers are left/right oriented, with the larger bumpers belonging on the same side as the log supports.

See Figure 3-9.

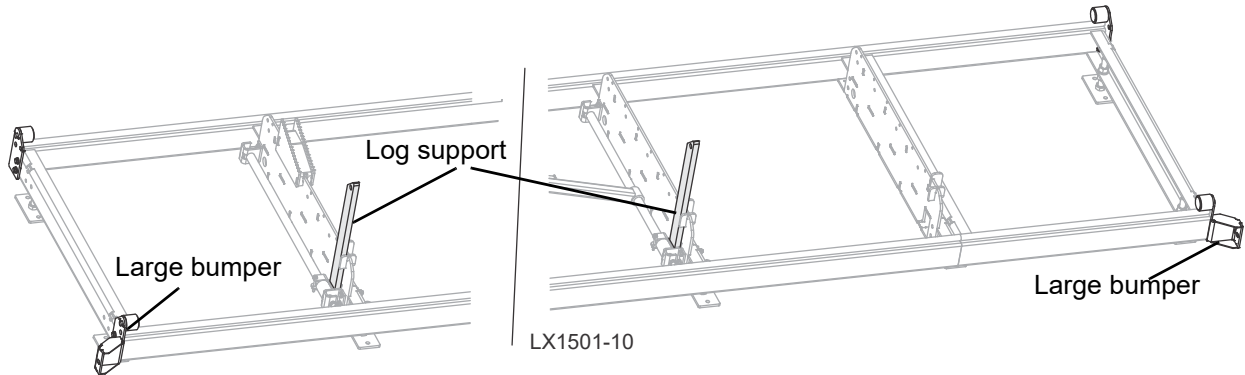

FIG. 3-9

1. Mount the bumpers to the frame with the shims between the frame and the bumpers.

See Figure 3-10.

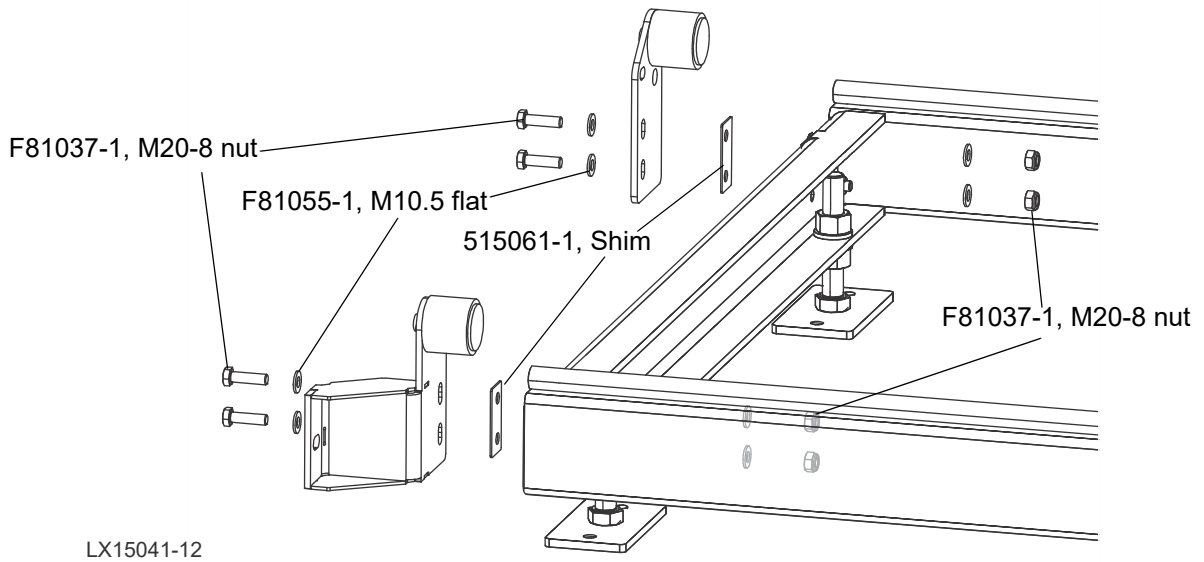

FIG. 3-10

Install Travel Locks



CAUTION! Do not attempt to move a fully assembled mill. Equipment damage will occur.

If relocation of the mill is necessary, the saw head and mast may be locked to ONE bed section for transport.

3

Sawmill Assembly

Leveling the bed

1. Remove the F81003-50 M10x80mm mounting bolts for the log support/clamp one bed section.
2. Remount the log support/clamp and the travel lock with the longer F05022-22 M10x90mm and the F05004-270 M10 nylock nuts.

See Figure 3-11.

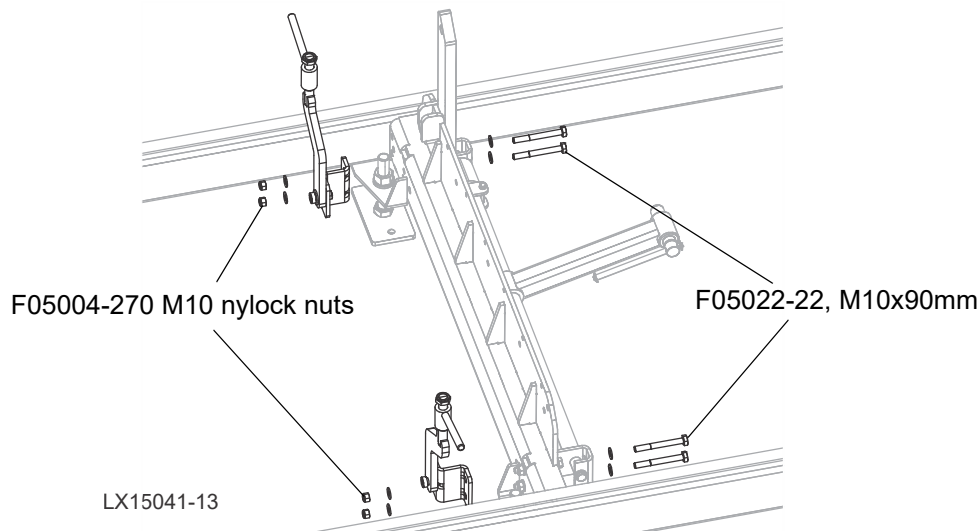

FIG. 3-11

Leveling the bed

NOTE: Leveling the bed is best done before setting the saw head on the log bed.

1. Adjust the frame legs so the sawmill appears level as shown in Figure 3-7 and 3-8.
2. Run a string from the front bed rail to the rear bed rail near the operator's side of the frame. See Figure 3-12.
3. Place **IDENTICAL** matching spacers between the string and the front and rear bed rails.
4. Measure the distance between the string and the other bed rails.
5. Adjust the frame legs until all bed rails measure the same distance from the string.

See Figure 3-12.

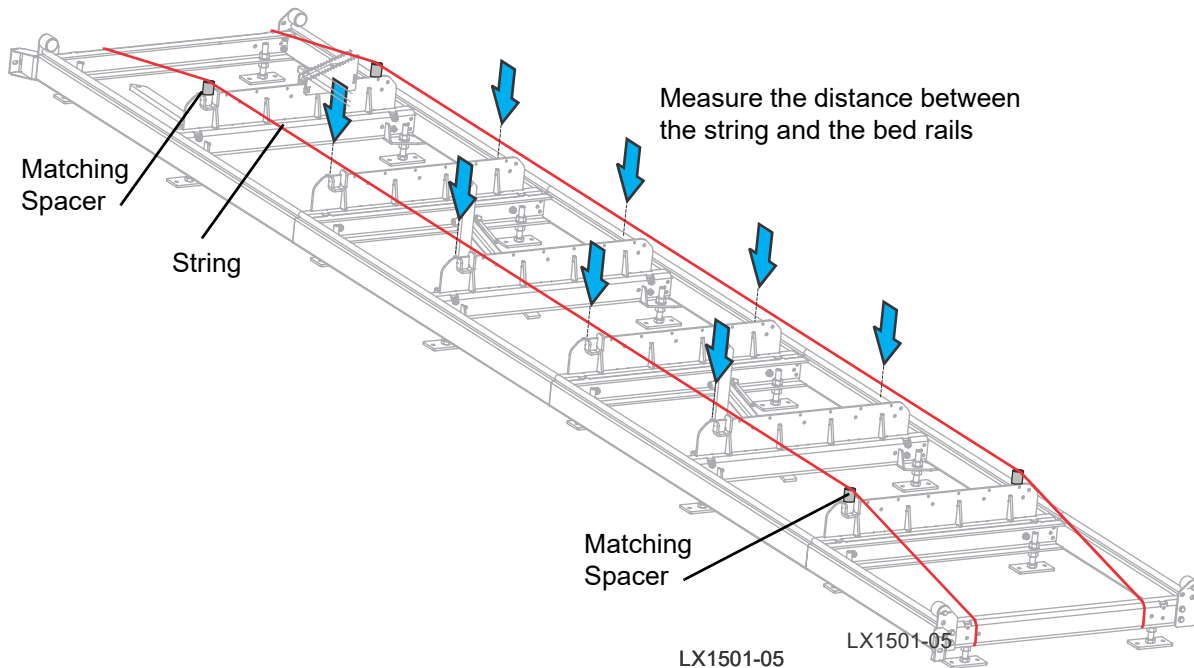

FIG. 3-12

6. Repeat the bed rail adjustment with the string at the other side of the sawmill frame.

3.4 Saw Mast Assembly



IMPORTANT! Do not attempt to set the carriage down on any surface that is not properly supported. Equipment damage will occur.

1. Check the orientation of the carriage before placing it on the bed frame; the operator is on the same side as the log supports.
2. Position the saw head over the end of the bed frame assembly.
3. Carefully slide the saw head rollers onto the bed frame track, keeping the saw head square to the bed to avoid jamming the track rollers.
4. Lower the saw head on the bed frame.
5. Mount the mast safety assembly to each track roller housing (one on the power feed side and two on the idle side).

3 Sawmill Assembly

Saw Mast Assembly

See Figure 3-13.

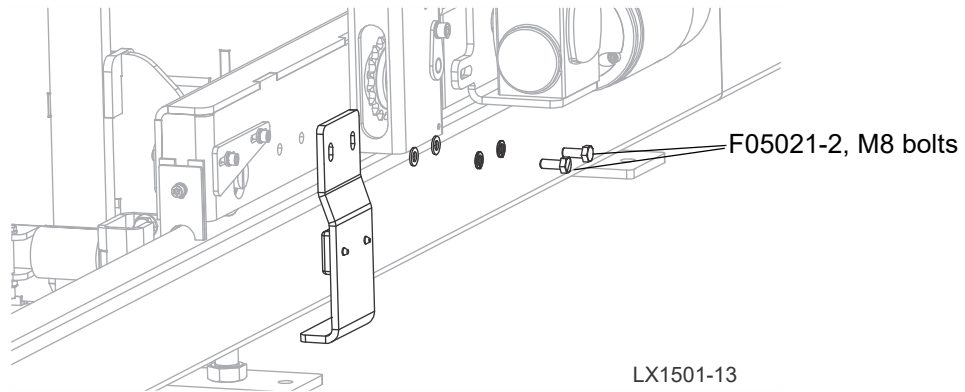

FIG. 3-13

6. Install all four the rail wipers on the mast rollers as shown in Figure 3-14.

The wiper should fit snugly on the rail while the mount should stay 1/8" above the rail.

See Figure 3-14.

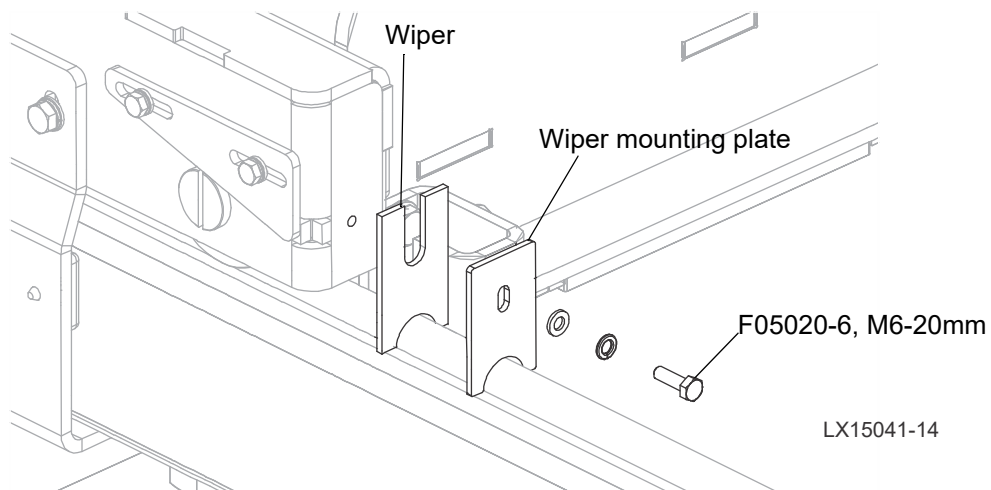

FIG. 3-14

7. Install the gas hoses to the tank.

See Figure 3-15.

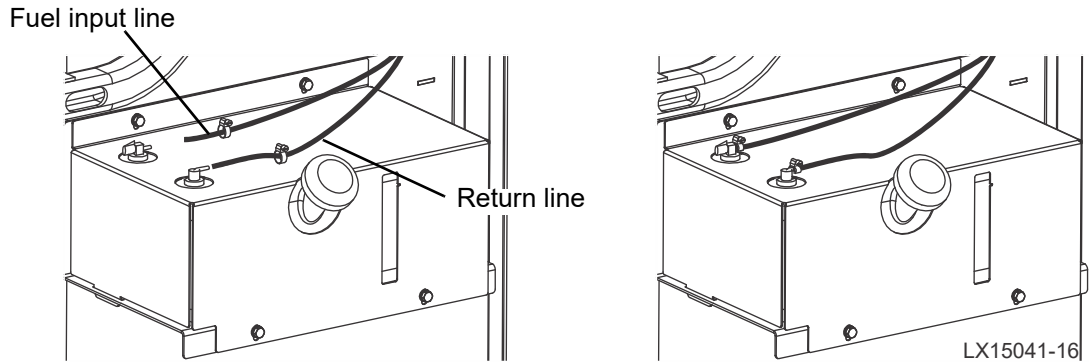

FIG. 3-15

8. Fill the water and fuel tank.

3.5 Feed Drive Rope Assembly

1. Thread one end of the feed rope through the bumper bracket at the front end of the bed assembly.
2. Slide one F05011-44 fender washer over the outside end of the rope.
3. Tie a knot in the rope at that end as shown in Figure 3-16.

See Figure 3-16.

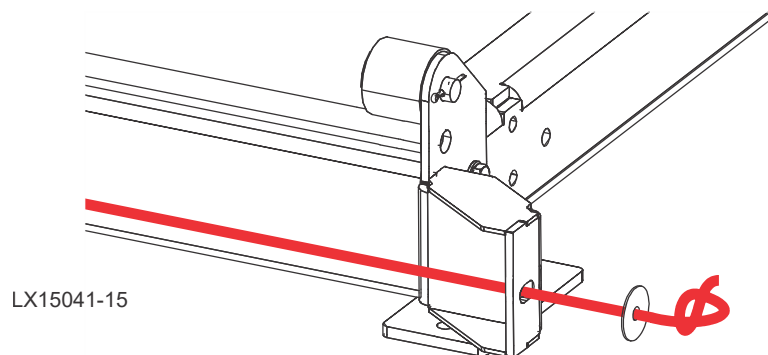

FIG. 3-16

4. Thread the feed rope through the pulleys of the feed drive assembly in a figure 8 pattern as shown in Figure 3-17.

3**Sawmill Assembly***Feed Drive Rope Assembly*

NOTE: The pulleys may be difficult to access, but it is not necessary to remove any parts.

See Figure 3-17.

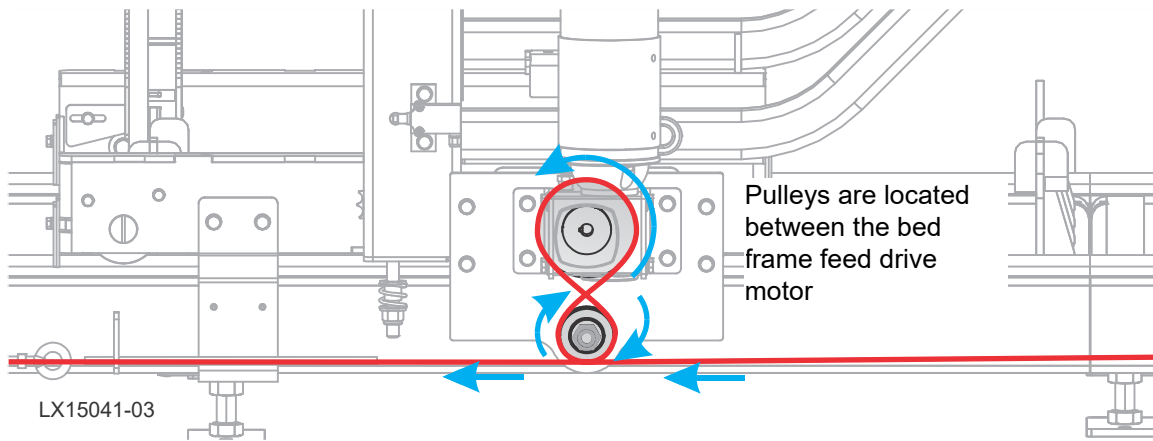

FIG. 3-17

5. Assemble the feed rope eyebolt in the rear bumper bracket as shown in Figure 3-18.
6. Thread the feed rope through the rope lock plate, the eyebolt, and back through the plate as shown in Figure 3-18.
7. Tie a knot in the end of the feed rope.
8. Adjust the feed rope tension by sliding the rope lock plate.

See Figure 3-18.

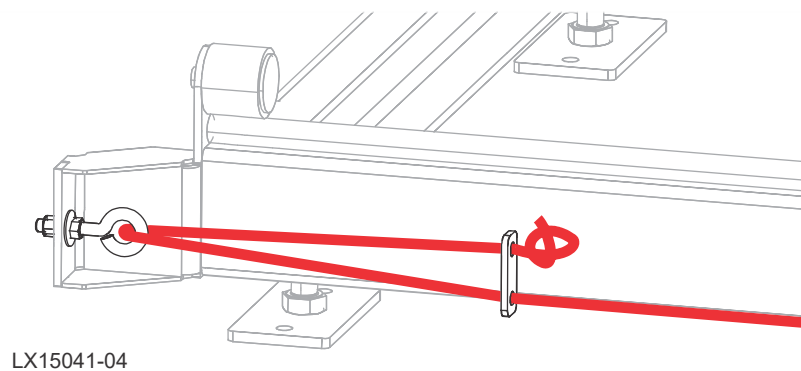

FIG. 3-18

3.6 Install the Blade



DANGER! COILED BLADES ARE UNDER SPRING TENSION. KNOW PROPER BLADE HANDLING BEFORE UNPACKING YOUR BLADE. FAILURE TO FOLLOW THIS WILL RESULT IN SERIOUS INJURY.



WARNING! Wear gloves and eye protection when handling bandsaw blades. Failure to follow this may result in serious injury.



WARNING! Keep all other persons away from area when coiling, carrying, or changing a blade. Changing blades is safest when done by one person. Failure to follow this may result in serious injury.

1. Watch the video on sawmill blades before removing the blade from the box.

NOTE: Do not remove the blade from the shipping box at this time.

2. Go to:



**HOW TO COIL, UNCOIL,
AND INVERT A BLADE**

<https://www.youtube.com/watch?v=43TWwSgSOaQ>

3. Open the blade housing cover.
4. Turn the blade tension bar with the ratchet until the blade wheel is moved in.

See Figure 3-19.

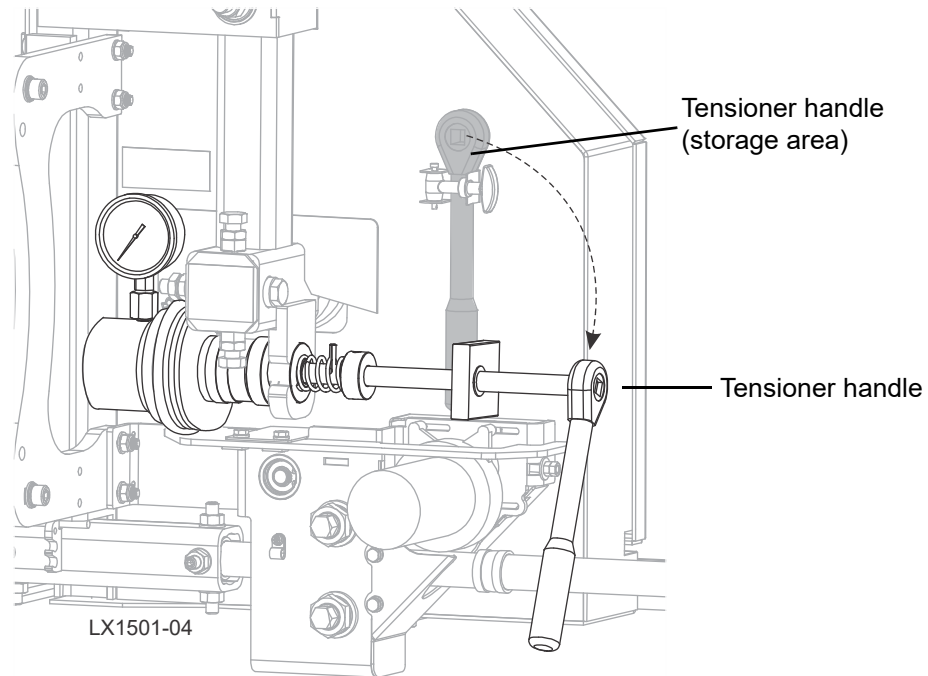

FIG. 3-19

5. Carefully remove and uncoil the blade from the shipping box.
6. Place the new blade around the blade wheels.

NOTE: When installing a blade, make sure the teeth are pointing the correct direction. The teeth should be pointing toward the operator side of the mill when you are looking at the blade below the blade guides. If necessary, invert the blade as shown in the video.

7. Position 1 1/4" wide blades (standard) on the wheels so the gullet is 1/8" (3.0 mm) out from the edge of the wheel.

SECTION 4 SAWMILL SETUP

The following setup procedure should be performed whenever the sawmill is moved or reassembled. If sawing problems occur and misalignment is suspected, [See Section SECTION 8](#) for complete alignment instructions.

[See Section SECTION 3](#) for sawmill assembly instructions.



DANGER! Do not use a gas engine indoors. Failure to follow this will result in serious injury or death.

NOTICE: Set up conditions include:

- Set up the sawmill on firm, level ground and level the sawmill.
- Use a sawdust collection system when operating under roof or indoors (electric only).
- When operating the sawmill outdoors, set up the sawmill placing the operator downwind to separate the operator from sawdust and/or engine exhaust gases.

4.1 Installing the Blade



WARNING! Wear gloves and eye protection when handling bandsaw blades. Failure to follow this may result in serious injury.



WARNING! Keep all other persons away from area when coiling, carrying, or changing a blade. Changing blades is safest when done by one person. Failure to follow this may result in serious injury.

1. Open the blade housing cover.
2. Turn the blade tension bar with the ratchet until the blade wheel is moved in.

See Figure 4-1.

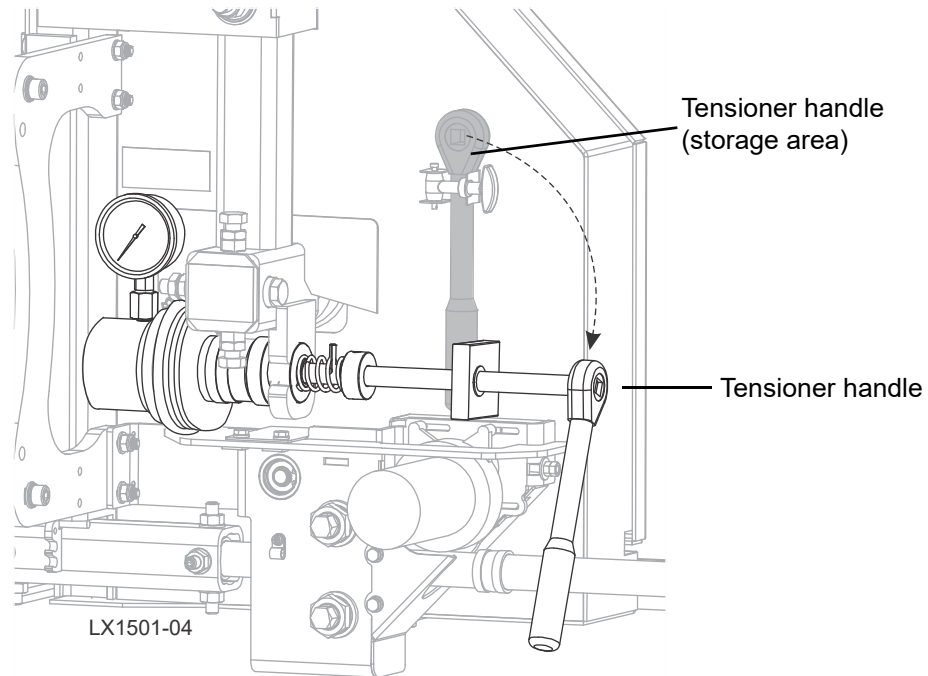

FIG. 4-1

3. Place the new blade around the blade wheels.

NOTE: When installing a blade, make sure the teeth are pointing the correct direction. The teeth should be pointing toward the operator side of the mill when you are looking at the blade below the blade guides.

4. Position 1 1/4" wide blades (standard) on the wheels so the gullet is 1/8" (3.0 mm) out from the edge of the wheel.

4.2 Tensioning The Blade

1. Use the supplied handle to turn the tensioner handle clockwise until the tension gauge indicates 1500-1700 PSI tension.

See Figure 4-2.

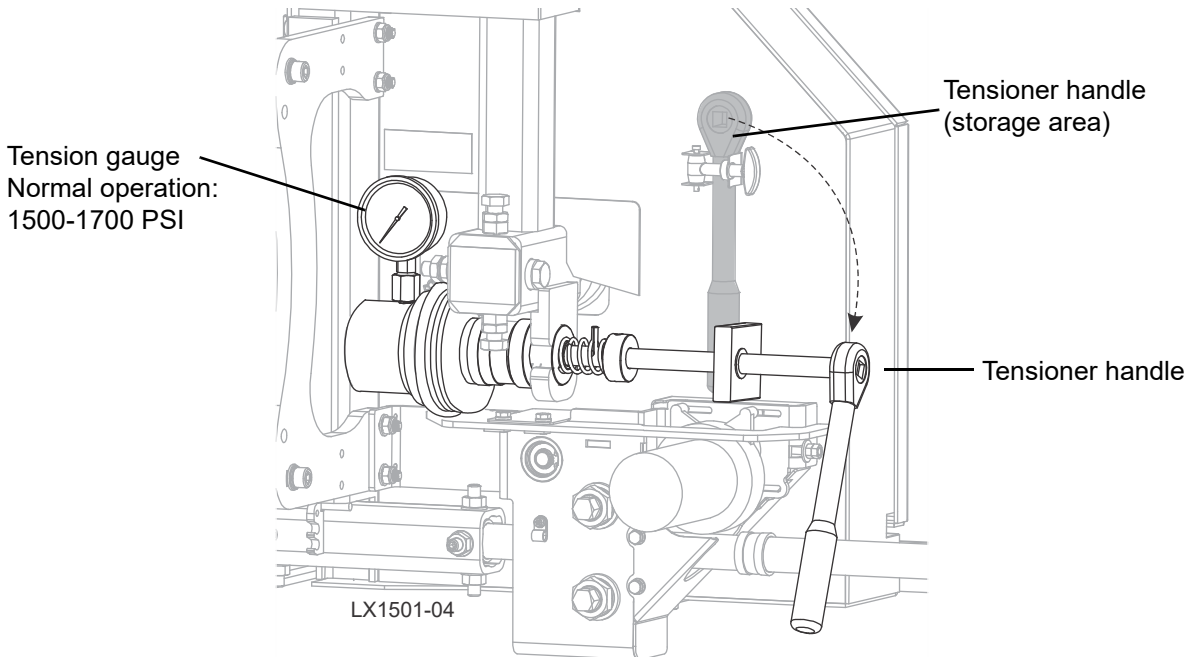

FIG. 4-2

2. Check the blade tension when adjusting the cant control or making other adjustments.

NOTE: Check the blade tension after prolong use. The blade and belts heat up and stretch, the blade tension will change.

3. Check the blade tension when there are changes in the ambient temperature.

4.3 Tracking The Blade



WARNING! Do not spin the blade wheels by hand. Failure to follow this may result in serious injury.

1. Ensure the blade housing cover is closed and all persons are clear of the open side of the saw head.

 **DANGER!** Always be sure the blade is disengaged and all persons are out of the path of the blade before starting the engine or motor. Failure to follow this will result in serious injury

 **WARNING!** Make sure all guards and covers are in place and secured before operating the sawmill. Failure to follow this may result in serious injury.

2. Start the engine.

NOTICE: See the appropriate manual supplied with your specific engine/motor configuration for starting and operating instructions.

See Figure 4-3.

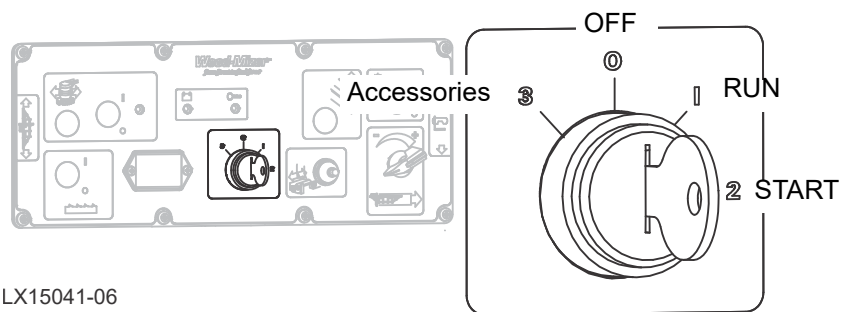

FIG. 4-3

3. Engage the blade momentarily, rotating the blade until the blade positions itself on the wheels.
4. Disengage the blade.
5. Turn off the engine, remove the key, and check the position of the blade on the blade wheels.
6. Use the cant control to adjust where the blade travels on the blade wheels.

NOTE: If the blade is too far out, back the blade onto the wheel by turning the cant control counterclockwise. If the blade is too far in, turn the cant control clockwise until the gullet of the blade is the correct distance from the front edge of the wheel.

See Figure 4-4.

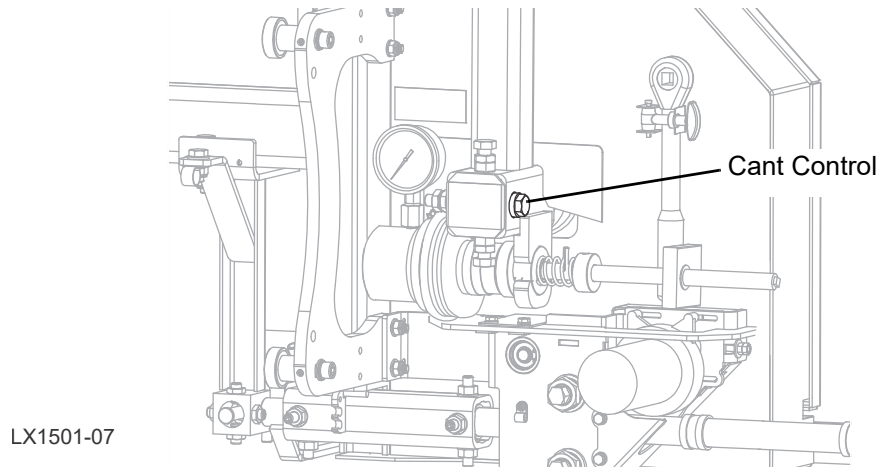

FIG. 4-4

7. Position 1 1/4" wide blades so the gullet is 1/8" (3.0 mm) out from the edge of the blade wheel ($\pm 1/32$ [.75 mm]).

See Figure 4-5.

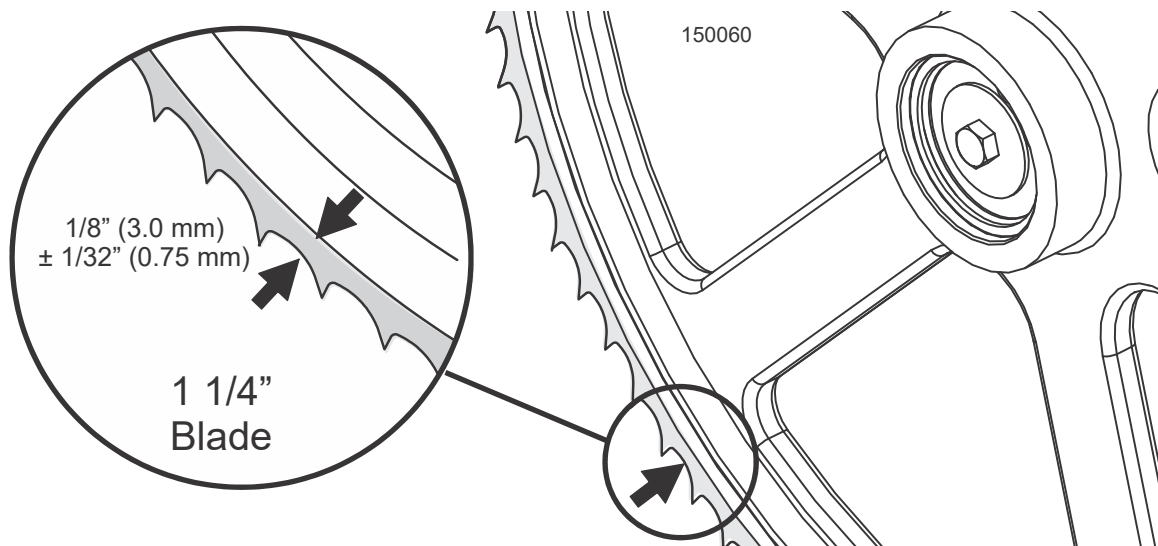

FIG. 4-5

8. Adjust the blade tension if necessary to compensate for any changes that may have occurred while adjusting the cant control.
9. Close the blade housing covers and ensure blade housing and pulley covers are in place and secure



WARNING! Make sure all guards and covers are in place and secured before operating the sawmill. Failure to follow this may result in serious injury or death.

NOTICE: After aligning the blade on the wheels, always double-check the blade guide spacing and location.

4.4 Sawblade

Blade Guide Vertical Tilt Alignment

The blade guides should be adjusted properly in the vertical plane. If the blade guides are tilted vertically, the blade will try to travel in the tilted direction.

A Blade Guide Alignment Tool (BGAT) is provided to help you measure the vertical tilt of the blade.

OUTER BLADE GUIDE

1. Open the adjustable blade guide arm 1/2" (13 mm) from fully open.
2. Clip the alignment tool on the blade.
3. Position the tool close to the outer blade guide assembly.

NOTE: Be sure the tool does not rest on a tooth or burr, and is lying flat against the bottom of the blade.

See Figure 4-6.

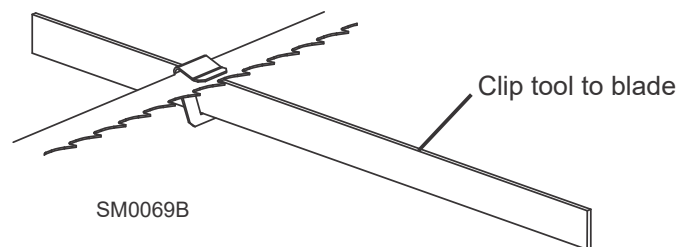

FIG. 4-6

4. Move the carriage so that the **front** end of the tool is positioned above the bed rail.
5. Measure the distance from the bed rail to the bottom edge of the tool.
6. Move the carriage so that the **back** end of the tool is positioned above the bed rail.

7. Measure the distance from the bed rail to the bottom edge of the tool.
8. If the measurement from the tool to the bed rail is not equal within 1/32" (.75 mm), adjust the vertical tilt of the outer blade guide roller.

See Figure 4-7.

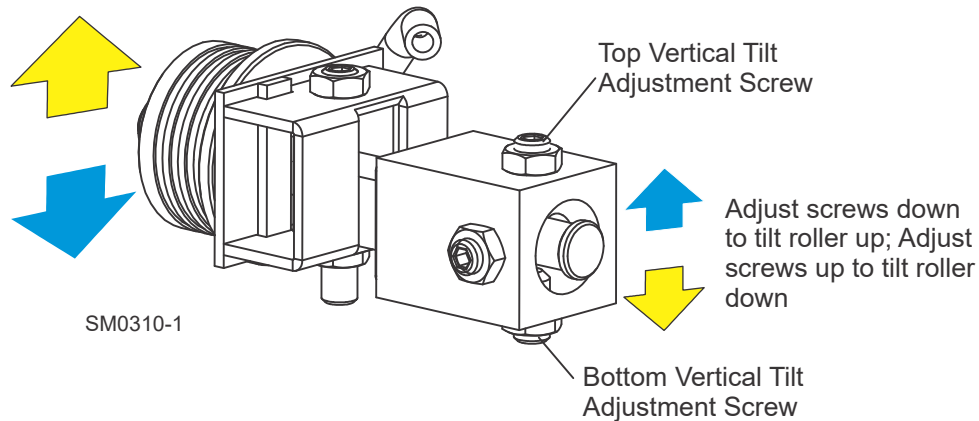

FIG. 4-7

9. Loosen one set screw at the side of the blade guide assembly.
10. Loosen the jam nuts on the top and bottom vertical tilt adjustment screws.
 - a. To tilt the roller up, loosen the bottom screw and tighten top screw.
 - b. To tilt the roller down, loosen the top screw and tighten the bottom screw.
11. Tighten the jam nuts and recheck the tilt of the blade.

INNER BLADE GUIDE

12. Move the blade guide alignment tool close to the inner blade guide roller assembly and repeat the above steps.
13. Adjust the vertical tilt of the inner blade guide, if necessary.

Blade Guide Flange Spacing

Each blade guide must be adjusted so the roller flange is the correct distance from the back edge of the blade. If the flange is too close to or too far from the blade, the sawmill will not cut accurately.

The blade guide rollers should also be slightly cocked. If the moving blade makes contact with the leading flange edge of the roller, momentum may cause the blade to slip over the flange. Contact with the trailing edge would force the blade upward onto the roller.

NOTICE: When adjusting blade guide spacing, **loosen the top set screw and one side set screw only.** This will ensure horizontal and vertical tilt adjustments are maintained when the adjustment screws are retightened.

OUTER BLADE GUIDE

1. Ensure that the distance between the flange on the **outer blade guide roller** to the back edge of the blade measures to 1/8" (3.0 mm).
2. Adjust the roller back or forward if necessary.

See Figure 4-8.

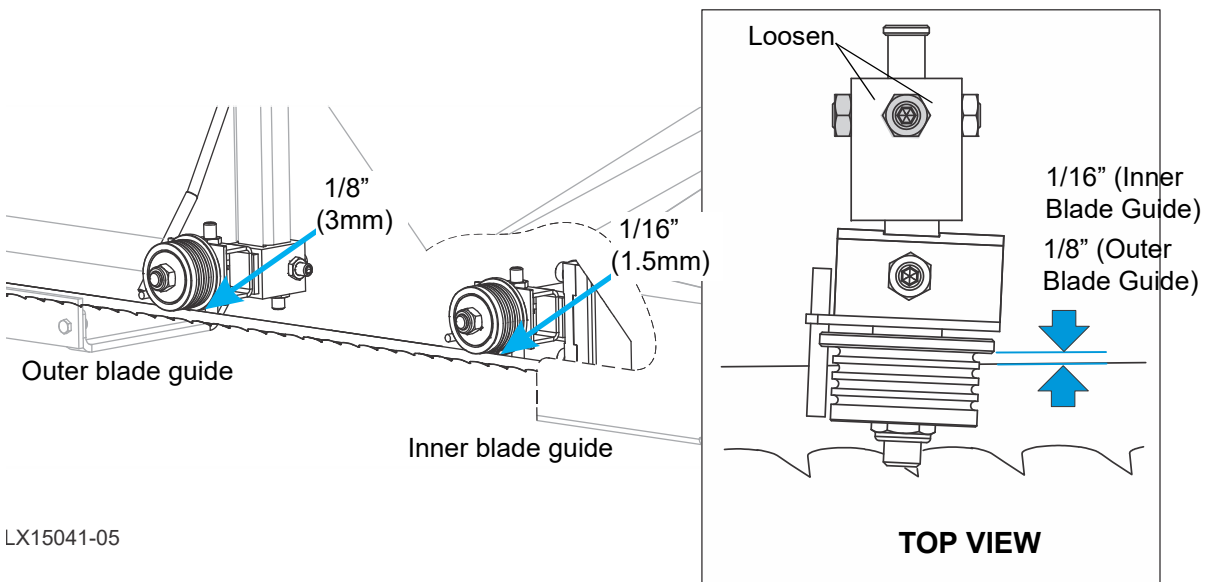

LX15041-05

FIG. 4-8

3. Loosen the top screw and one side screw.
4. Gently tap the blade guide forward or backward until properly positioned.
5. Retighten the screws and jam nuts.

INNER BLADE GUIDE

6. Ensure that the distance between the flange on the **inner blade guide roller** to the back edge of the blade measures to 1/16" (1.5 mm). See Figure 4-8.
7. Adjust the roller back or forward, as described above.

4.5 Starting The Engine

DANGER! Always be sure the blade is disengaged and all persons are out of the path of the blade before starting the engine or motor. Failure to follow this will result in serious injury



WARNING! Make sure all guards and covers are in place and secured before operating the sawmill. Failure to follow this may result in serious injury.

Electrical systems will run with the key in the Accessories (3) position; however, you risk running your battery down.

See the manual supplied with your specific engine/motor configuration for starting and operating instructions.

See **Figure 4-9**.

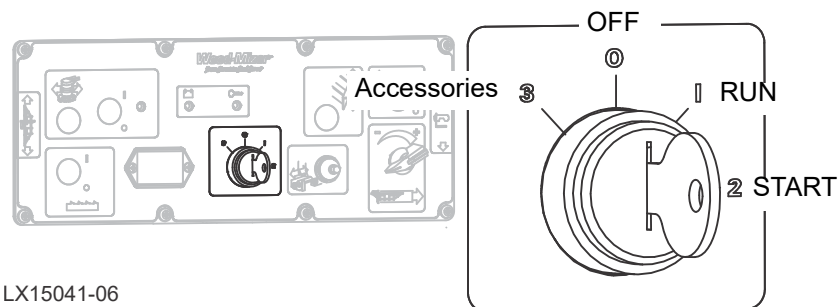

FIG. 4-9

SECTION 5 SAWMILL OPERATION

5.1 Power Feed

The power feed system moves the carriage forward and backward by using the two switches on the control panel illustrated below.

See Figure 5-1.

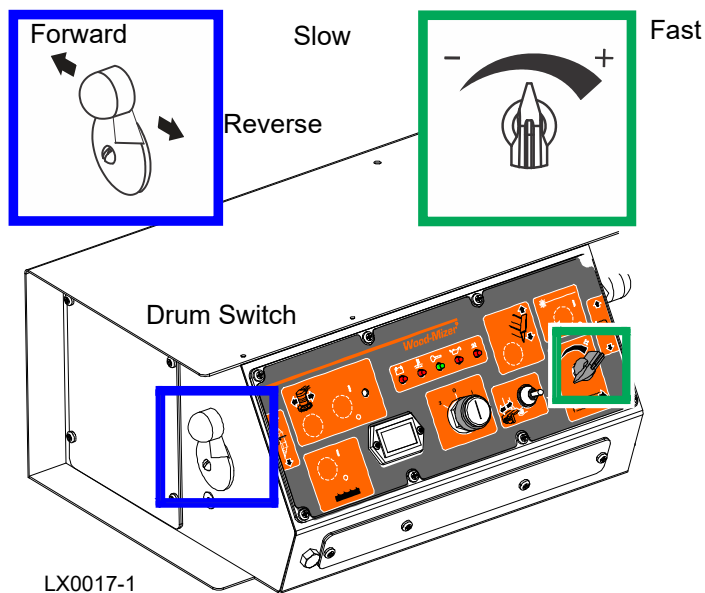

FIG. 5-1

CARRIAGE FORWARD AND REVERSE

The carriage forward/reverse drum switch controls the direction in which the carriage travels.

NOTICE: If the forward/reverse operation is backwards, the wiring on the Power Feed motors is reversed. Rewire the motors.

The middle position (as shown) is the neutral position. The power feed switch is designed to return to the neutral or "off" position when released from operating in the reverse position. If the switch remains engaged, manually move the switch to the neutral or "off" position and [See Section 5.6](#).



WARNING! Ensure the power feed switch is in the neutral position before turning the key switch to the on (#1) or accessory (#3) position to prevent accidental carriage movement. Failure to follow this will result in death or serious injury.

CARRIAGE FEED RATE

The carriage feed rate switch controls the speed at which the carriage travels forward. Turn the switch clockwise to increase speed. Turn it counterclockwise to reduce speed.

USING THE POWER FEED

1. Use the forward/reverse drum switch and the feed rate switch to position the sawhead for the cut.
2. Engage the clutch to start the blade.
3. Set the feed rate relative to the size and material you are cutting. If not known, set at the slowest rate.

HINT: To get a straight cut in the first part of the board, feed the blade into the log at a slow speed. Turn the carriage feed rate switch to a slow speed until the whole width of the blade has entered the cut. This stops the blade from flexing and dipping up or down. Then use the carriage feed rate switch to increase the feed rate as desired. Maximum feed rate varies with width and hardness of the wood. Over-feeding results in engine and blade wear, and also produces a wavy cut.

4. Press and lock power feed handle forward to move forward.
5. Stop the carriage at the end of the cut by raising (unlocking) the feed handle, or by turning the carriage feed rate switch counterclockwise until the carriage stops moving.
6. Disengage the blade by setting the clutch handle up. The engine will drop to idle.
7. Remove the board from the top of the log.



CAUTION! Be sure to stop the blade when returning the carriage. This will not only prevent the blade from being pulled off and ruined by a wood sliver, but also will increase the life of the blade.

8. Raise the carriage slightly to ensure the blade clears the log when returned.
9. Return the carriage to the front of the mill by pushing the forward/reverse drum switch back.



IMPORTANT! The power feed motor will bypass the carriage feed rate switch and the carriage will automatically return at the fastest speed available.

 **DANGER!** Stay clear of the area between the trailer axle and saw carriage. Failure to follow this will result in death or serious injury.

5.2 Up/Down Operation

 **CAUTION!** Ensure the blade is properly installed and tensioned before moving the sawhead.

1. Use the up/down drum switch located on the right side of the control panel to raise or lower the cutting head.
2. Hold the switch in position until the cutting head reaches the desired height, then release.

See Figure 5-2.

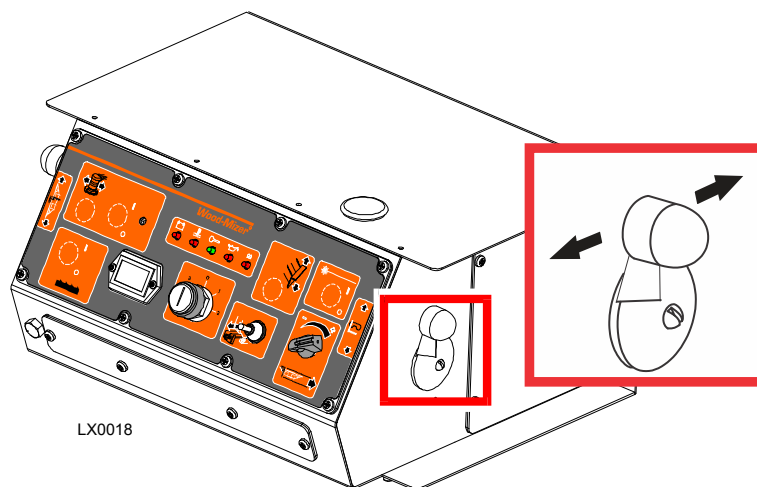



FIG. 5-2

 **CAUTION!** Ensure the up/down drum switch moves to the neutral (off) position when released to ensure that the saw head stops moving. If the switch remains engaged, manually move the switch to the neutral or "off" position, then troubleshoot the switch.

 **CAUTION!** DO NOT try to force the carriage above the 35" (88 cm) mark or below the 1" (2.54 cm) mark. Damage to the up/down system may result.

5.3 Loading, Turning, & Clamping Logs

LOADING LOGS

1. Move the saw carriage to the front end of the frame.



CAUTION! Before loading a log, be sure the cutting head is moved far enough forward so the log does not hit it. Failure to follow this may result in machine damage.



IMPORTANT! The saw carriage may be moved without the engine started, but repeated operation in this manner may drain your battery.

2. Adjust the log clamps all the way down and to the loading side of the sawmill frame.



CAUTION! Be sure the log clamps are adjusted out of the path of the log before loading a log onto the bed. Failure to follow this may result in machine damage.

3. Raise the side supports on the sawmill bed to prevent the log from falling off the side of the bed.
4. Position the log at the foot of the ramps.

NOTE: Logs also may be loaded onto the mill with a tractor or other equipment specifically designed for that purpose.

5. Use a cant hook to roll the log up the ramps and onto the sawmill bed. Position the log against the side supports.

NOTE: Position the log on the bed sections to maximize support of the log by the bed. If the log overhangs the bed, (particularly if the optional bed extension is installed) it may tend to sag, resulting in inaccurately sawn lumber.

6. Remove the log ramps and set aside.

TURNING LOGS

7. Use cant hooks to rotate the log on the sawmill bed. Spin the log against the side supports until it is turned the way you want it for the first cut.

CLAMPING LOGS



CAUTION! Make sure the side supports and clamp are positioned low enough for the blade to pass over them. If they are not, back the clamp off slightly and push the side supports down until they are positioned below the level of your first few cuts. Failure to follow this will result in machine damage.

1. Slide the clamp against the log and turn the locking handle to lock the clamp against the log.
2. Tighten the clamp against the log with the locking handle.

See Figure 5-3.

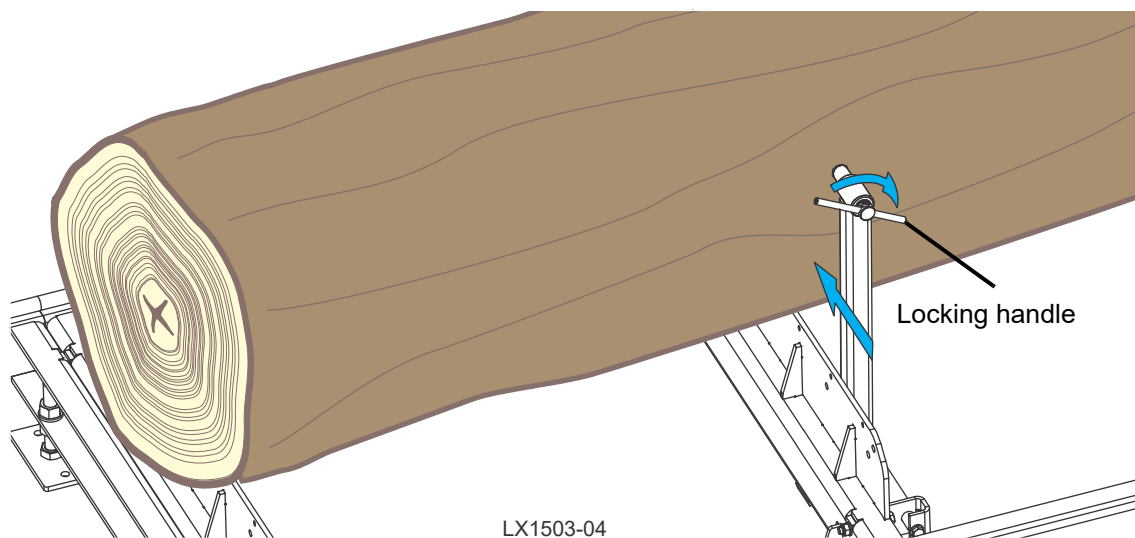

FIG. 5-3

LEVELING A TAPERED LOG

Use shims or the wedge to raise either end of a tapered log until the heart of the log measures the same distance from the bed rails at each end of the log.

See Figure 5-4.

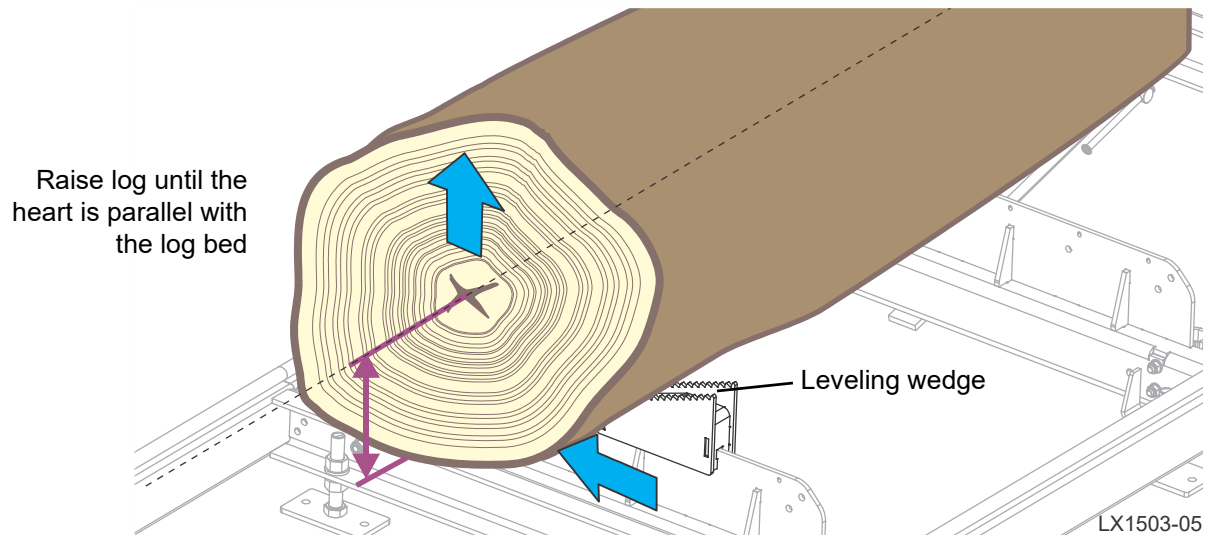

FIG. 5-4

5.4 Blade Guide Arm Operation

1. Set the outer blade guide to clear the widest section of the log by less than 1" (25.4 mm).
2. Use the blade guide toggle switch on the control panel to adjust the outer blade guide as necessary.
3. Push the switch to the left to move the arm in; push the switch to the right to move the arm out.

See Figure 5-5.

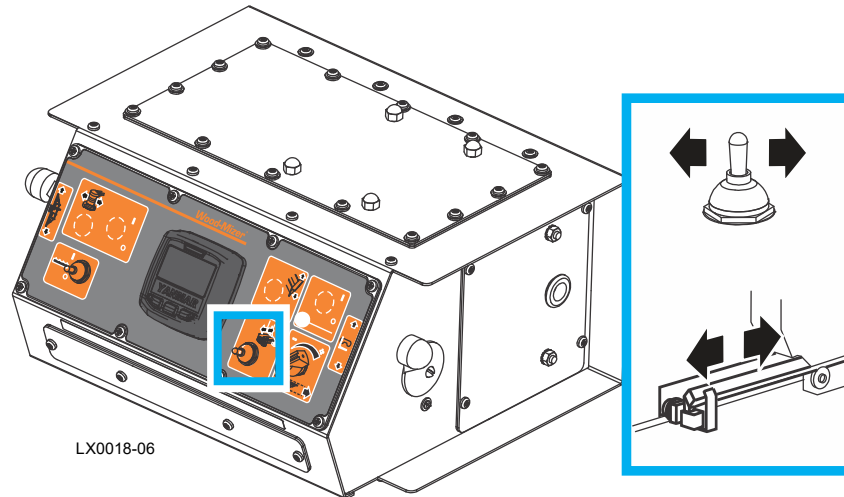

FIG. 5-5

4. Use the blade guide toggle switch to readjust the outer blade guide as you are cutting in order to keep the guide within 1" (2.5 cm) of the log.
5. Adjust the arm out before returning the carriage.

5.5 Cutting The Log

1. Once the log is placed where you want it and clamped firmly, move the saw head to position the blade close to the end of the log.
2. Use the blade height scale to determine where to make your first cut ([See Section 5.7](#)).

The blade height scale will help you to do this. Set the blade to the desired height with the up/down crank. Make sure that the blade will clear all side supports and the clamps. Adjust the outer blade guide to clear the widest section of the log by moving the blade guide arm knob.

3. Engage the clutch to start the blade spinning.
4. Start the water lube if necessary to prevent sap buildup on the blade. [See Section 5.8](#).
5. Feed the blade into the log slowly ([See Section 5.5](#)).

Once the blade completely enters the log, increase the feed rate as desired. Always try to cut at the fastest speed you can while keeping an accurate cut. Cutting too slowly will waste blade life and lower production! As you get to the end of the log, slow down the feed rate.

6. When the teeth exit the end of the log, disengage the clutch and remove the cut slab.
7. Return the carriage to the front of the mill.
8. Repeat until the first side of the log is cut as desired.
9. Set aside the usable flitches (boards with bark on one or both sides) to edge them later.
10. Remove the wedge if it was used.
11. Remove the clamps and turn the log 90 or 180 degrees.

Make sure the flat on the log is placed flat against side supports if turned 90 degrees or it is placed on bed rails if turned 180 degrees.



IMPORTANT! If the log was turned 90 degrees and you are using the wedge to compensate for taper in the log, use the wedge again on the second side of the log until the heart is parallel with the bed.

12. Repeat the steps used to cut the first side of the log until the log is square. Cut boards from the remaining cant by adjusting the blade height for the thickness of boards that you want.



IMPORTANT! Remember that the blade cuts a 1/16 - 1/8" (1.6-3.2 mm) wide kerf. If you want 1" (25.4 mm) thick boards, lower the carriage 1 1/16 - 1 1/8" (27-28.6 mm) for each board.

5.6 Edging

1. Raise the side supports to 1/2 the height of the flitches, or the boards that need to be edged.
2. Stack the flitches on edge against the side supports.
3. Clamp the flitches against the side supports halfway up the flitch height.

Wider flitches should be placed to the clamp side. When they are edged, flip them over to edge the second side without disturbing the other flitches or without having to pull them from the middle of the stack.

4. Adjust the blade height to edge a few of the widest boards.
5. Loosen the clamps and turn the edged boards over to edge the other side.
6. Repeat steps 2-4.

- Loosen the clamps and remove the boards that have good clean edges on both sides. Clamp the remaining flitches and repeat steps 2-5.

5.7 Blade Height Scale

See Figure 5-6.

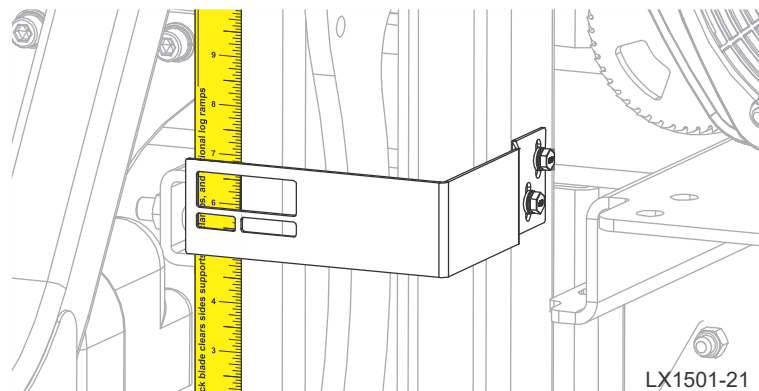

FIG. 5-6

THE INCH SCALE

The horizontal line on the blade height indicator shows how many inches the bottom of the blade is above the bed of the mill. If you know the height of your blade at each cut, you can determine the thickness of lumber you are sawing.

Example: You want to cut 1" (25 mm) random width boards from a log. Position the blade for the first cut. Move the carriage to an even measurement on the inch scale. Make a trim cut. Return the carriage for the second cut and lower it 1 1/8" (29 mm) below the original measurement. (The extra 1/8" (3 mm) allows for saw kerf and shrinkage of the lumber.)



IMPORTANT! The yellow area on the scale identifies where the blade could encounter a side support or log clamp. Check that these items are below the blade level before sawing.

THE QUARTER SCALE

See Table 5-1. The magnetic quarter scale has four sets of marks. Each set represents a specific lumber thickness. Saw kerf and shrinkage allowance are included, but actual board thickness will vary slightly depending on blade thickness and tooth set.

Standard Quarter Scale

TABLE 5-1

5 Sawmill Operation

Water Lube Operation

Scale	Actual Board Thickness
4/4	1" (25 mm)
5/4	1 1/4" (32 mm)
6/4	1 1/2" (38 mm)
8/4	2" (51 mm)

TABLE 5-1

To use the quarter scale, look at the blade height indicator.

Position the magnetic quarter scale over the inch scale. Align one of the quarter scale marks with the horizontal line on the indicator.

Make a trim cut. When you return the carriage for a second cut, lower the carriage to the next mark on the scale. This mark shows where the blade should be positioned to cut a certain thickness of lumber, without having to measure on the inch scale.

Example: You want to cut 1" (25 mm) (4/4) random width boards from a log. Position the blade for the first cut. Position the magnetic quarter scale so a 4/4 mark is aligned with the line on the indicator. Make a trim cut. Return the carriage for the second cut. Now, instead of having to measure down 1 1/8" (29 mm) on the inch scale, you can simply lower the blade so the indicator is aligned with the next 4/4 mark on the quarter scale. Turn the log 90 degrees and repeat.

5.8 Water Lube Operation

The Water Lube System keeps the blade clean. Water flows from a 5-gallon (18.9 liter) bottle through a hose to the blade guide where the blade enters the log. A valve in the bottle cap controls the amount of water flow. Normal flow is 1-2 gallons (3.8-7.6 liters) per hour.

See Figure 5-7.

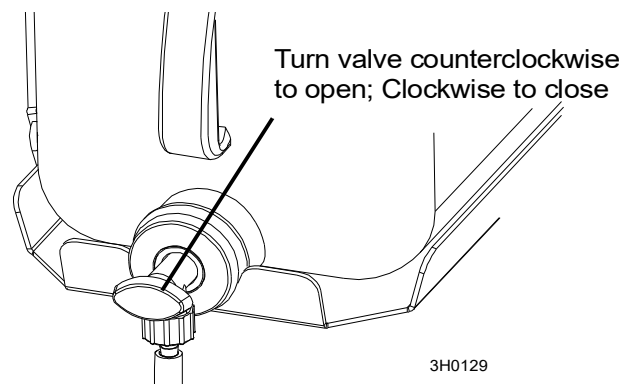

FIG. 5-7

Not all types of wood require the use of the Water Lube System. When it is needed, use just enough water to keep the blade clean. This saves water, and lowers the risk of staining the boards with water.

When changing blades, let the blade spin with water running on it for about 15 seconds before removing it. This will clean the blade of sap buildup. Dry blade with a rag before storing or sharpening.

For lubrication benefits, add one 12oz. (0.35L) bottle of Wood-Mizer Lube Additive to 5 gallons (18.9 liters) of water. Wood-Mizer Lube Additive enables some previously impossible timbers to be cut by significantly reducing resin buildup on the blade. It helps to reduce heat buildup, wavy cuts, and blade noise. This biodegradable and environmentally friendly pre-mix includes a water softener additive, so it works with hard water.



WARNING! Use ONLY water and Wood-Mizer Lube Additive with the water lube accessory. Never use flammable fuels or liquids such as diesel fuel. If these types of liquids are necessary to clean the blade, remove it and clean with a rag. Failure to follow this can damage the equipment and may result in serious injury or death.

If you are sawing in freezing temperatures, remove the water lube bottle from the sawmill when done sawing and store it in a warm place. Blow any remaining water from the water lube hose.

5.9 Transporting the Sawmill

THE LX150 SAWMILL IS NOT INTENDED TO BE PORTABLE. If it is necessary to move the sawmill, it should be dismantled in a reverse order as described in the assembly procedures. Transportation should be done in the same configuration as originally shipped to the customer.

SECTION 6 MAINTENANCE



WARNING! Turn the key switch to the OFF (0) position and remove the key before performing service near moving parts such as blades, pulleys, motors, belts, and chains. If the key is turned on and moving parts activated, serious injury or death may result.

See the [Maintenance chart](#) located after this section for a complete list of maintenance procedures and intervals. Keep a log of machine maintenance by recording in the machine hours and the date you perform each procedure.



This symbol identifies the interval (hours of operation) at which each maintenance procedure should be performed.

Be sure to refer to option and engine manuals for other maintenance procedures.

6.1 Wear Life

See Table 6-1. This chart lists estimated life expectancy of common replacement parts if proper maintenance and operation procedures are followed. Due to the many variables which exist during sawmill operation, actual part life may vary significantly. This information is provided so that you may plan ahead in ordering replacement parts.

Part Description	Estimated Life
B57 Blade Wheel Belts	400 hours
Blade Guide Rollers	1000 hours
Drive Belt	1250 hours

TABLE 6-1

6.2 Blade Guides



WARNING! Turn the key switch to the OFF (0) position and remove the key before performing service near moving parts such as blades, pulleys, motors, belts, and chains. If the key is turned on and moving parts activated, serious injury or death may result.

1. Check the rollers for performance and wear every blade change.
2. Replace any rollers which are not clean, not spinning freely, or have worn smooth or misshaped.

6.3 Changing The Blade



WARNING! Turn the key switch to the OFF (0) position and remove the key before performing service near moving parts such as blades, pulleys, motors, belts, and chains. If the key is turned on and moving parts activated, serious injury or death may result.



WARNING! Wear gloves and eye protection when handling bandsaw blades. Failure to follow this may result in serious injury.



WARNING! Keep all other persons away from area when coiling, carrying, or changing a blade. Changing blades is safest when done by one person. Failure to follow this may result in serious injury.

1. Open the blade housing cover.
2. Turn the blade tension bar with the ratchet until the blade wheel is moved in.

See Figure 6-1.

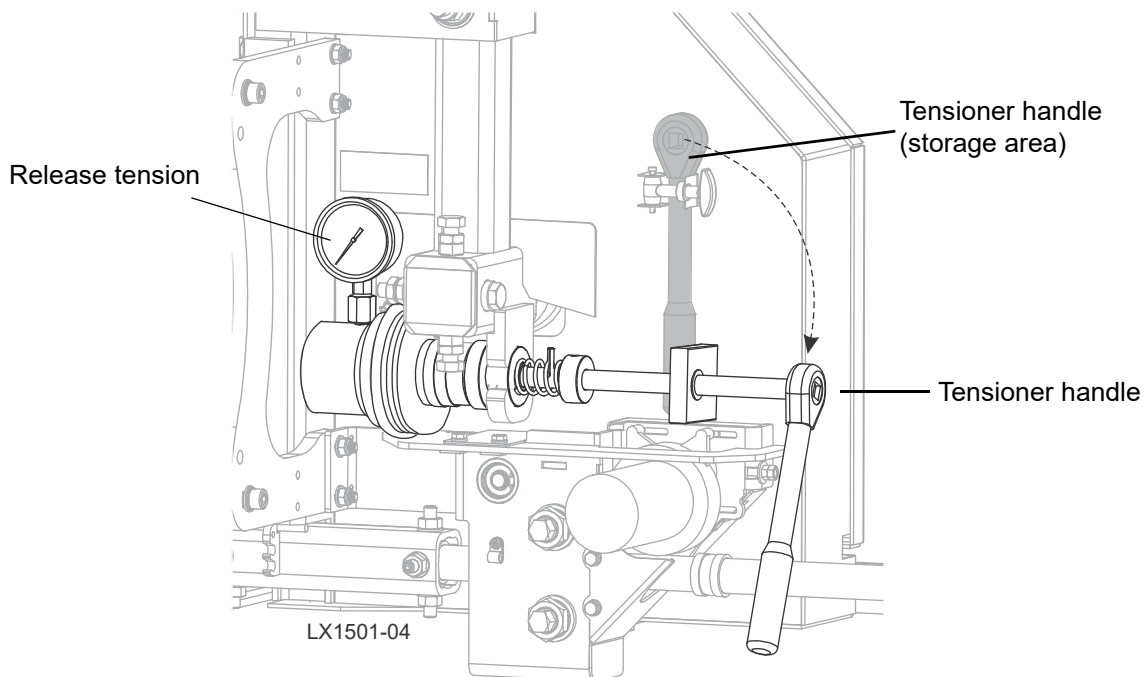

FIG. 6-1

3. Place the new blade around the blade wheels.

6

Maintenance Sawdust Removal

When installing a blade, make sure the teeth are pointing toward the operator side of the mill when you are looking at the blade below the blade guides.

4. Position 1 1/4" wide blades (standard) on the wheels so the gullet is 1/8" (3.0 mm) out from the edge of the wheel.

See Figure 6-2.

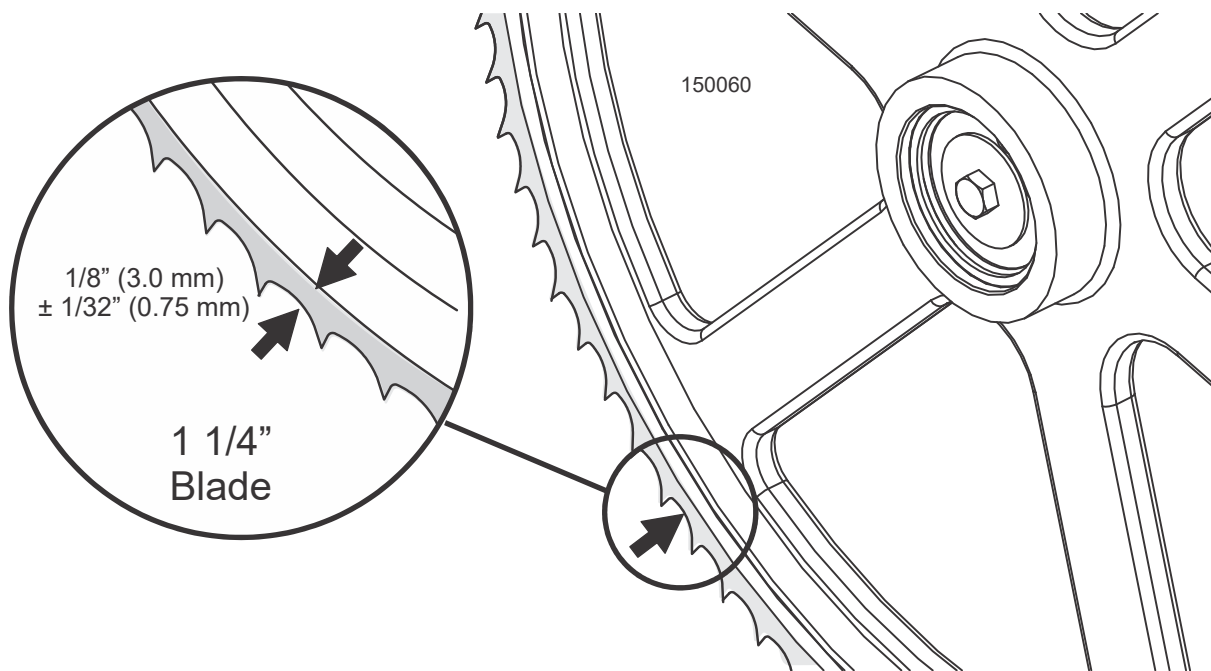

FIG. 6-2

5. Close the blade housing cover.

6.4 Sawdust Removal



WARNING! Turn the key switch to the OFF (0) position and remove the key before performing service near moving parts such as blades, pulleys, motors, belts, and chains. If the key is turned on and moving parts activated, serious injury or death may result.



Remove the excess sawdust from the blade wheel housings and sawdust chute every blade change.



WARNING! Keep hands, feet and any other objects away from the sawdust chute when operating sawmill. Failure to follow this may result in serious injury or death.



WARNING! Ensure the steel fingers inside the sawdust chute are in place before operating the sawmill. Failure to have these fingers in place may result in serious injury or death.

The steel fingers have been designed to help prevent a broken blade or some other object from becoming a projectile and exiting the sawdust chute.

Remove sawdust buildup from rope feed pulleys and up/down chain sprockets as necessary.

6.5 Mast Track, Wipers, & Scrapers



WARNING! Turn the key switch to the OFF (0) position and remove the key before performing service near moving parts such as blades, pulleys, motors, belts, and chains. If the key is turned on and moving parts activated, serious injury or death may result.

Properly maintaining the sawmill mast track is critical in preventing corrosion that can cause pitting and scaling on the rail surfaces. Pitted and scaled surfaces can, in turn, cause rough cuts or jerky feed movement.

1. Clean track rails to remove any sawdust and sap buildup every eight hours of operation.

8

Use a light-grade sandpaper or emery cloth to sand off any rust or other adhering particles from the rails.



CAUTION! Keep track rails free of rust. Formation of rust on the track rail in the areas where the cam bearings roll can cause rapid deterioration of the track rail's surface.

2. Lubricate the rails by wiping them with Dexron III ATF transmission fluid.

Lubrication will help protect the rails from corrosive elements such as acid rain and/or moisture from nearby bodies of saltwater (if applicable). This lubrication is essential to maintain the integrity of the track rails and track rollers and to achieve long service life.

3. Remove sawdust from the track roller housings and brush any sawdust buildup from the housings every twenty-five hours of operation.

25

4. Check the track scrapers (2 per track roller housing) for a firm fit against the rail.

AR

If a track scraper needs to be adjusted, loosen the screw, push the scraper downward until it fits firmly against the rail, and retighten the screw.

See Figure 6-3.

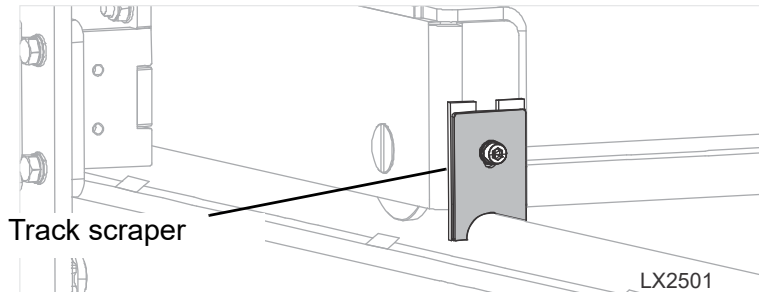

FIG. 6-3

6.6 Vertical Mast Rails



WARNING! Turn the key switch to the OFF (0) position and remove the key before performing service near moving parts such as blades, pulleys, motors, belts, and chains. If the key is turned on and moving parts activated, serious injury or death may result.



Wipe the vertical mast rails with Dexron III ATF transmission fluid every 50 hours of operation.



CAUTION! Never use grease on the mast rails as it will collect sawdust.

6.7 Miscellaneous



WARNING! Turn the key switch to the OFF (0) position and remove the key before performing service near moving parts such as blades, pulleys, motors, belts, and chains. If the key is turned on and moving parts activated, serious injury or death may result.



1. Oil all chains with Dexron III ATF every fifty hours of operation.



CAUTION! Do not use chain lube. It causes sawdust buildup in chain links.





2. Grease the clamps and side support pivots with a NLGI No. 2 grade lithium grease every fifty hours of operation.
3. Check the mill alignment after every setup ([See Section SECTION 7](#)).
4. Make sure all safety warning decals are readable.

Remove sawdust and dirt covering warning decals. Replace any damaged or unreadable decals immediately. Order decals from your Customer Service Representative.

5. Replace the idle blade wheel belt as necessary. (Use only belts supplied by Wood-Mizer.)

6.8 Drive Belt Adjustment

 **WARNING!** Turn the key switch to the OFF (0) position and remove the key before performing service near moving parts such as blades, pulleys, motors, belts, and chains. If the key is turned on and moving parts activated, serious injury or death may result.

 **WARNING!** For battery-powered equipment, disconnect the negative battery terminal cable. Failure to follow this may result in injury or death.

 **WARNING!** For electrical motors, disconnect and lockout power before performing any service to the electrical system. Failure to follow this may result in injury or death.

 **WARNING!** Do not adjust the engine drive belts or belt support bracket with the engine running. Doing so may result in serious injury or death.

 **See Table 6-2.** See the table below for drive belt tension specifications. Measure the belt tension with a gauge, as shown in Fig 6-4.

New Belt Installation		
Check After	Deflection	Force
20 hrs	7/16" (11mm)	8 lbs. (3.63 kg)

Subsequent Adjustment		
Check Every	Deflection	Force
50 hrs	7/16" (11mm)	8 lbs. (3.63 kg)

TABLE 6-2

ADJUST THE DRIVE BELT TENSION

1. Use the Tension Gauge (part number 016309) supplied with your Wood-Mizer to measure the drive belt tension.
2. Zero out the pounds indicator by sliding the small o-ring against the yellow flange.
3. Open the access hole in the belt cover and place the tension gauge firmly against the belt.
4. Set the large o-ring even with the belt cover.

6

Maintenance

Drive Belt Adjustment

5. Add 1/2" (12.5mm) to that measurement and reset the large o-ring to the belt cover + 1/2" (12.5mm) setting.
6. Press down on the rubber boot; stop pressing when the large o-ring meets the edge of the belt cover.

See Figure 6-4.

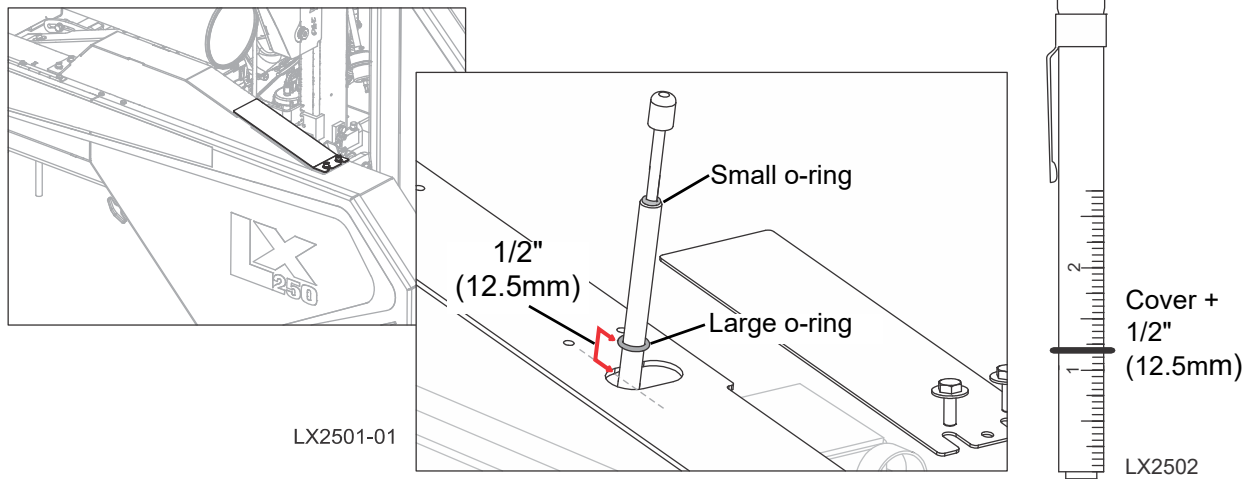

FIG. 6-4

7. Read the pounds indicated by the small O-ring; it should read 8 lbs (3.63 kg).
8. If the reading is too high or low, use the clutch cable adjustment nuts to correct the tension.

See Figure 6-5.

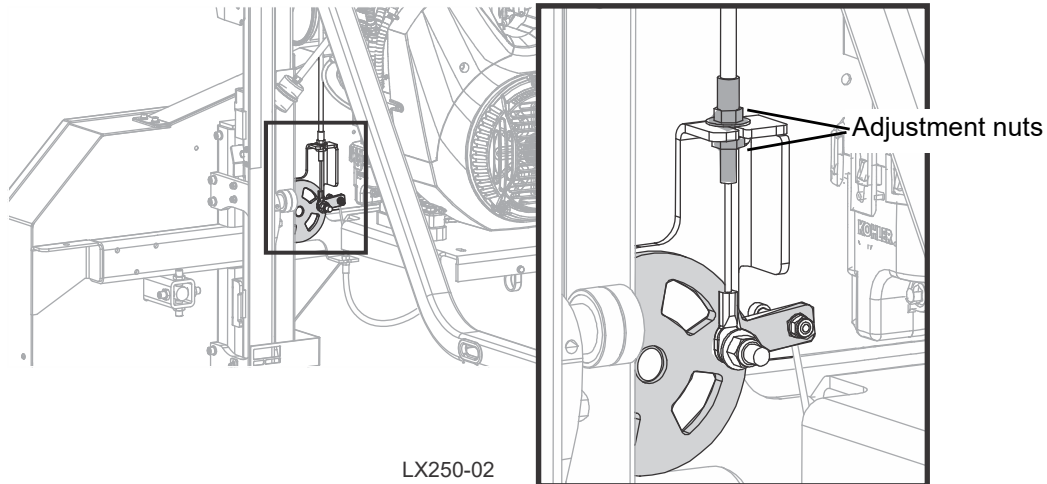

FIG. 6-5

6.9 Up/Down System



WARNING! Turn the key switch to the OFF (0) position and remove the key before performing service near moving parts such as blades, pulleys, motors, belts, and chains. If the key is turned on and moving parts activated, serious injury or death may result.

ADJUST THE UP/DOWN CHAIN AS NEEDED.



The up/down chain is adjusted to level the sawhead.

1. Locate the chain adjusting bolt at the bottom of the mast.
2. Loosen the adjustment nut provided on the bottom of the sprocket assembly and move the sprocket up/down until the sawhead is level.
3. Repeat on the other side as necessary.

See Figure 6-6.

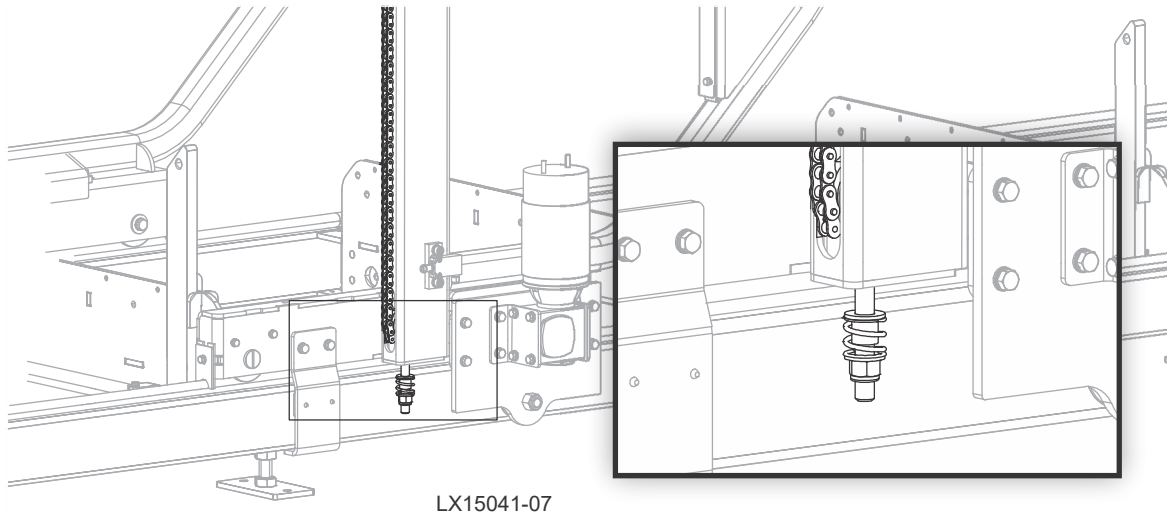







FIG. 6-6

6.10 Charging The Battery

-  **WARNING!** Turn the key switch to the OFF (0) position and remove the key before performing service near moving parts such as blades, pulleys, motors, belts, and chains. If the key is turned on and moving parts activated, serious injury or death may result.
-  **WARNING!** Batteries expel explosive gases; keep sparks, flames, burning cigarettes, or other ignition sources away at all times. Failure to follow this will result in serious injury or death.
-  **WARNING!** Always wear safety goggles and a face shield when working near batteries. Failure to follow this could result in serious injury or death.
-  **WARNING!** Wash hands after handling batteries to remove possible lead, acid, or other contaminants. Failure to follow this could result in serious injury or death.
-  **WARNING!** Charge the battery in a well ventilated area. Failure to follow this could result in serious injury or death.
-  **WARNING!** Do not attempt to charge a frozen battery. Failure to follow this could result in serious injury or death.

NOTICE: When working with batteries, use extreme care to avoid spilling or splashing electrolyte (dilute sulfuric acid) as it can destroy clothing and burn the skin.

EMERGENCY TREATMENT FOR CONTACT WITH BATTERY COMPONENTS (LEAD/SULFURIC ACID) per SDS (Safety Data Sheet):

EYE CONTACT	Sulfuric Acid and Lead: Flush eyes immediately with large amounts of water for at least 15 minutes while lifting lids. Seek immediate medical attention if eyes have been exposed directly to acid.
SKIN CONTACT	Sulfuric Acid: Flush affected area(s) with large amounts of water using deluge emergency shower, if available, shower for at least 15 minutes. Remove contaminated clothing, including shoes. If symptoms persist, seek medical attention. Wash contaminated clothing before reuse. Discard contaminated shoes. Lead: Wash immediately with soap and water.
INGESTION	Sulfuric Acid: Administer large amounts of water. Do NOT induce vomiting or aspiration into the lungs may occur and can cause permanent injury or death; consult physician.
INHALATION	Sulfuric Acid: Remove to fresh air immediately. If not breathing, give artificial respiration. If breathing is difficult, give oxygen. Consult a physician. Lead: Remove from exposure, gargle, wash nose and lips; consult physician.



CAUTION! Do not overcharge the battery. Overcharging may reduce the overall service life of the battery.



CAUTION! Be sure the battery is fully charged before transporting the sawmill. If the battery is not fully charged, excessive vibration could reduce the overall service life of the battery.

1. Turn the key to the OFF (0) position and remove the key.
2. Remove the battery box lid.
3. Clean the battery terminals, if necessary.
4. Connect the positive charger/jumper cable directly to the positive battery terminal.
5. Connect the negative charger/jumper cable to a grounded metal surface.
6. Follow the instructions supplied with your specific battery charger.



IMPORTANT: Be careful not to overcharge the battery, especially when using a high-rate or “boost” charger (40 amps or higher). These

6**Maintenance***Charging The Battery*

are intended to quickly charge a good battery that is discharged. They are not intended for unattended or long-term charging.

7. After the battery is completely recharged, remove the negative charger/jumper cable from ground.
8. Remove the positive charger/jumper cable from the battery.
9. Replace the battery box lid.

SECTION 7 TROUBLESHOOTING GUIDE

7.1 Sawing Problems



WARNING! Turn the key switch to the OFF (0) position and remove the key before performing service near moving parts such as blades, pulleys, motors, belts, and chains. If the key is turned on and moving parts activated, serious injury or death may result.

PROBLEM	CAUSE	SOLUTION
Blades Dull Quickly	Dirty logs	Clean or debark logs, especially on entry side of the cut
	When grinding teeth, heating too much and causing teeth to soften	Grind just enough metal to restore sharpness to the teeth. Use water/coolant while sharpening blade
	Poor sharpening techniques	Make sure the tip is being sharpened completely: Read the instructions with your blade sharpening equipment carefully
Blades break prematurely	Poor sharpening techniques	Read the instructions with your blade sharpening equipment carefully
	Rubber belts on idle blade wheel worn to a point that blade contacts metal pulley - look for shiny spots on edge of wheels	Change idle blade wheel belts
	Tension too tight	Tension blade to recommended specifications
Blade does not track right on drive wheel	Cant adjustment is incorrect	Readjust
Blade guides do not spin while cutting	Frozen bearings	Replace bearings
Drive belts wear prematurely or jump	Engine/motor and drive pulleys out of alignment	Align pulleys
Boards thick or thin on ends or middle of board.	Stress in log which causes log to not lay flat on the bed.	After log has been squared, take equal cuts off opposing sides. Take a board off the top. Turn the log 180 degrees. Take a board off. Repeat, keeping the heart in the middle of the cant, and making it your last cut.
	Set in teeth.	Resharpen and reset blade.
	Bed rails misaligned.	Realign sawmill bed.

TABLE 7-0

7 Troubleshooting Guide

Sawing Problems

PROBLEM	CAUSE	SOLUTION
Height adjustment jumps or stutters when moving up or down.	Up/down chain improperly adjusted.	Adjust up/down chain.
	Vertical wear pads are too tight.	Adjust pads.
Lumber is not square	Vertical side supports not square to bed	Adjust side supports.
	Blade not parallel to bed rails	Adjust bed rails parallel to blade.
	Sawdust or bark between cant and bed rails	Remove particles
Sawdust builds up on track	Tooth set problems	Resharpen and reset blade
	Excessive oiling	Do not oil track
	Track wipers worn	Adjust wipers to firmly contact track
	Track is sticky	Clean track with solvent and apply silicone spray
Wavy cuts	Excessive feed	Slow feed rate
	Improperly sharpened blade (This will be the problem 99% of the time!)	Resharpen blade, following the sharpener's instructions carefully
	Blade guides improperly adjusted	Adjust blade guides.
	Sap buildup on blade	Use Water Lube.
	Tooth set problem	Resharpen and reset blade

TABLE 7-0

SECTION 8 SAWMILL ALIGNMENT

Two alignment procedures are available to realign the sawmill if necessary. The Routine Alignment instructions should be performed as necessary to solve sawing problems not related to blade performance. The Complete Alignment procedure should be performed approximately every 1500 hours of operation.

NOTICE: These steps build on each other and should be performed in sequence.

8.1 Routine Alignment Procedure

Prepare the sawmill for alignment.

Adjust the blade parallel to the bed rails.

Adjust the blade guide arm parallel to the saw head main tube.

Align blade guide arm parallel to the blade.

Adjust side supports square to the bed.

Final adjustments.

Prepare the sawmill for alignment.

Before performing the setup procedures from Section 3: setup the mill on firm, level ground, level the bed, and adjust the legs so the entire frame is level.

BLADE REPLACEMENT

1. Remove the blade and check the blade wheel belts.
2. Remove any sawdust buildup from the surface of the belts.
3. Replace worn belts if they do not keep the blade from contacting the blade wheel.
4. Perform subsections [4.1 Tensioning the Blade](#), and [4.3 Tracking the Blade](#).

Blade Guide Arm Alignment**BLADE GUIDE ARM PARALLEL TO THE SAW HEAD MAIN TUBE**

The blade guide arm moves the outer blade guide in and out. If the arm becomes loose, the blade guide will not deflect the blade properly, causing inaccurate cuts. A loose blade guide arm can also cause blade vibration.

1. Adjust the blade guide arm out to within 1/2" (13 mm) of fully open (blue/right position in Figure 8-1).

NOTE: When adjusting the blade guide arm screws, be careful not to tighten the screws too much or put the arm in a bind. Operate the blade guide arm to ensure the arm moves easily in and out.

2. Adjust the arm up until the slide pad touches the saw head main tube by
 - a. loosening the inner jam nuts (blue),
 - b. loosening the upper screw,
 - c. tightening the lower screw, and
 - d. tighten both jam nuts.

See Figure 8-1.

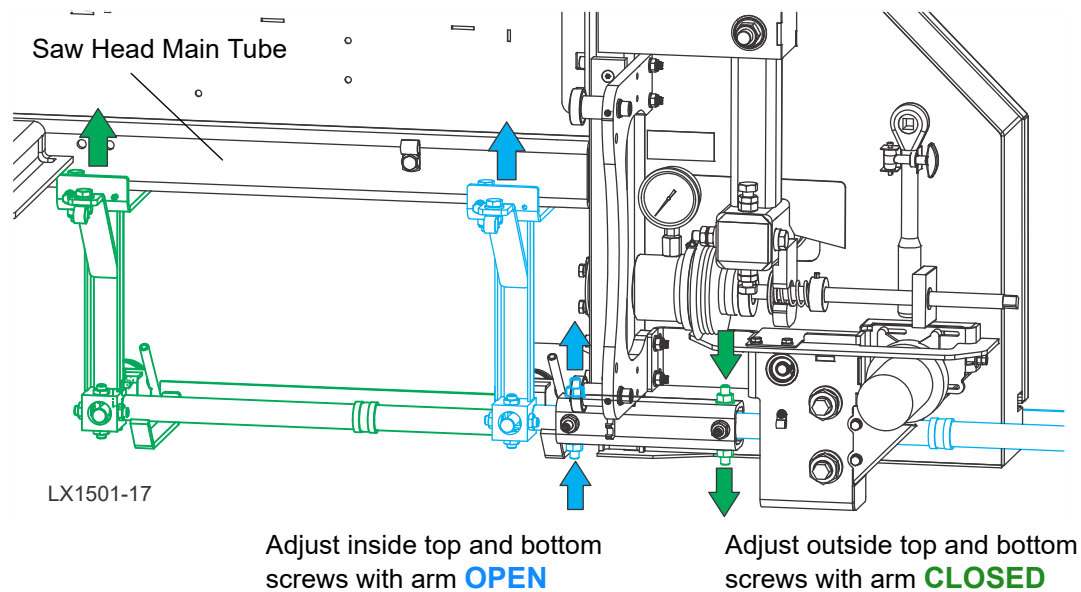

FIG. 8-1

3. Adjust the blade guide arm in all the way closed (green/left position in Figure 8-1).
4. Adjust the arm up until the slide pad touches the saw head main tube by
 - a. loosening the outer jam nuts (green),
 - b. tightening the upper screw,
 - c. loosening the lower screw, and
 - d. tightening both jam nuts.

BLADE GUIDE ARM PARALLEL TO THE BLADE

1. Open the idle side front saw head cover to gain access to the front side blade guide arm side adjustment screws.

See Figure 8-2.

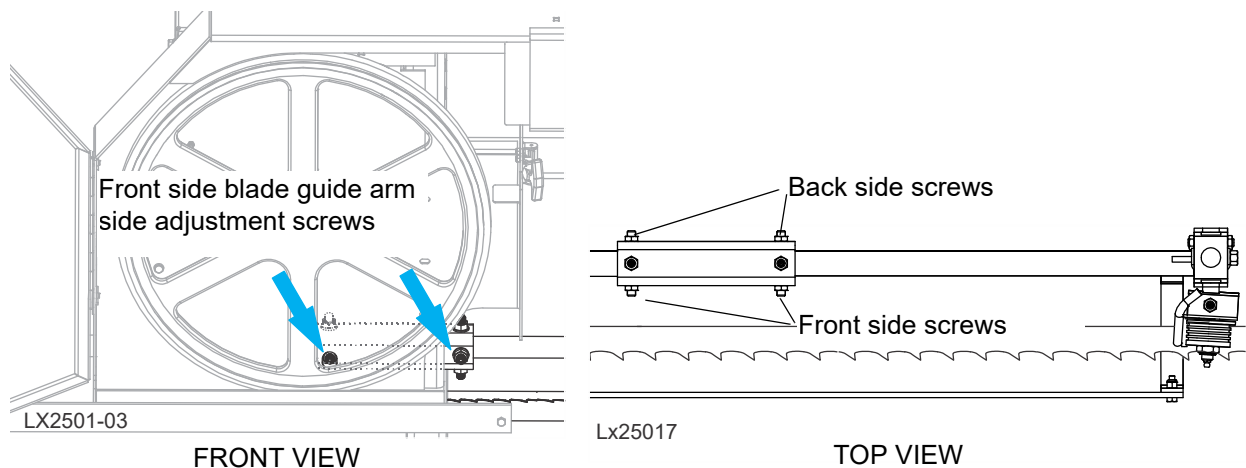

FIG. 8-2

2. With the blade guide arm still all the way closed, **lightly** tighten all the side screws (two front, two back) until they touch the arm.
3. Back the screws off 1/4 turn and tighten the jam nuts.

8 Sawmill Alignment

Blade Guide Arm Alignment

See Figure 8-3.

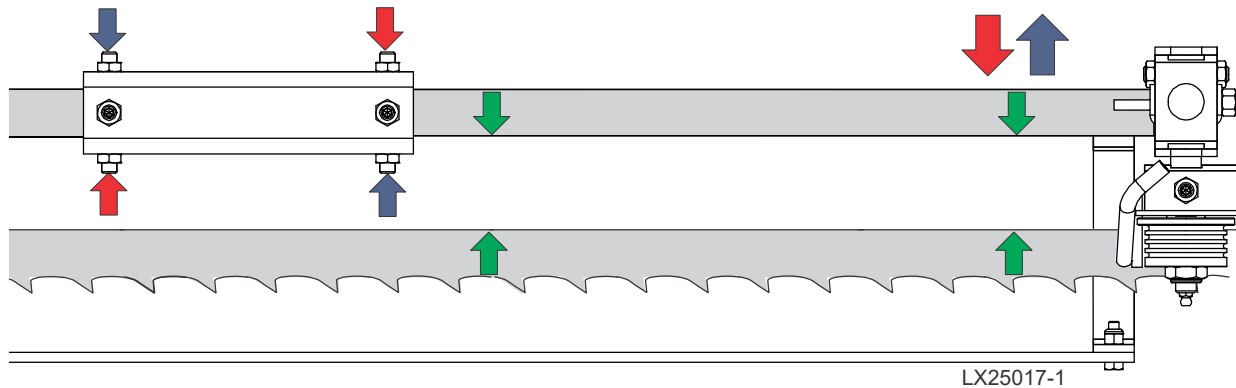

FIG. 8-3

4. Measure the distance between the blade guide arm and back edge of the blade.
5. Adjust the appropriate side screws on the blade guide arm housing so the arm measures the same distance from the blade at both ends of the arm.

BLADE GUIDE ARM TO THE REAR OF THE SAWMILL

1. Loosen jam nuts on the front inside screw and the rear outside screw (blue arrows in Figure 8-3).
2. Turn the screws counterclockwise one full turn and tighten the jam nuts.
3. Loosen the jam nuts on the front outside screw and the rear inside screw.
4. Turn the screws clockwise until they touch the arm.
5. Back off 1/4" turn, and tighten the jam nuts.

BLADE GUIDE ARM TO THE FRONT OF THE SAWMILL

1. Loosen jam nuts on the front outside screw and the rear inside screw (red arrows in Figure 8-3).
2. Turn the screws counterclockwise one full turn and tighten the jam nuts.
3. Loosen the jam nuts on the front inside screw and the rear outside screw.
4. Turn the screws clockwise until they touch the arm.

5. Back off 1/4" turn, and tighten the jam nuts.

Blade Guide Vertical Tilt Alignment

The blade guides should be adjusted properly in the vertical plane. If the blade guides are tilted vertically, the blade will try to travel in the tilted direction.

A Blade Guide Alignment Tool (BGAT) is provided to help you measure the vertical tilt of the blade.

6. Open the blade guide arm to within 1/2" (13 mm) of fully open.
7. Clip the alignment tool on the blade.

NOTICE: Position the tool close to the outer blade guide assembly. Be sure the tool does not rest on a tooth or burr, and is lying flat against the bottom of the blade.

See Figure 8-4.

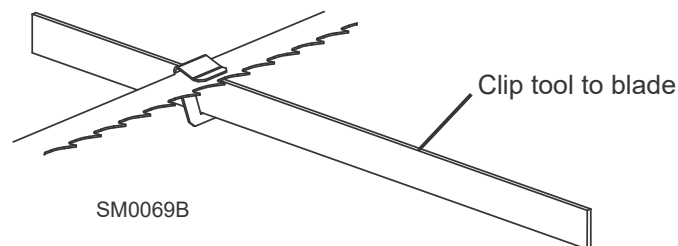

FIG. 8-4

8. Move the mast so that the front end of the tool is positioned above the bed rail.
9. Measure the distance from the bed rail to the bottom edge of the tool.
10. Move the mast so that the back end of the tool is positioned above the bed rail.
11. Measure the distance from the bed rail to the bottom edge of the tool.
12. If the measurement from the tool to the bed rail is not equal within 1/32" (.75 mm), adjust the vertical tilt of the outer blade guide roller.

See Figure 8-5.

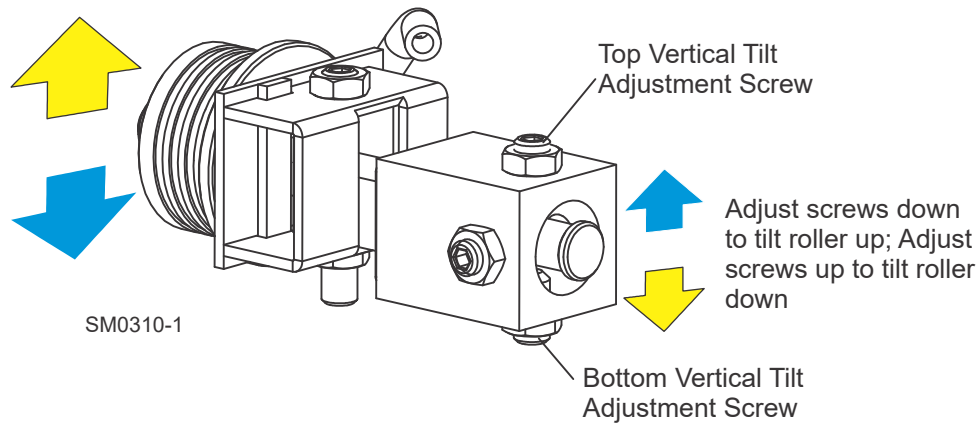

FIG. 8-5

13. Loosen one set screw at the side of the blade guide assembly.
14. Loosen the jam nuts on the top and bottom vertical tilt adjustment screws.

To tilt the roller up, loosen the bottom screw and tighten top screw. To tilt the roller down, loosen the top screw and tighten the bottom screw.
15. Tighten the jam nuts and recheck the tilt of the blade.
16. Move the blade guide alignment tool close to the inner blade guide roller assembly and repeat the above steps.
17. Adjust the vertical tilt of the inner blade guide, if necessary.

Blade Guide Horizontal Tilt Adjustment

If the blade guides are tilted in the wrong direction horizontally, the back of the blade may contact the flange as the roller is spinning down, causing it to push the blade away from the guide roller.

1. Remove the blade guide alignment tool from the blade and adjust the blade guide arm halfway in.

See Figure 8-6.

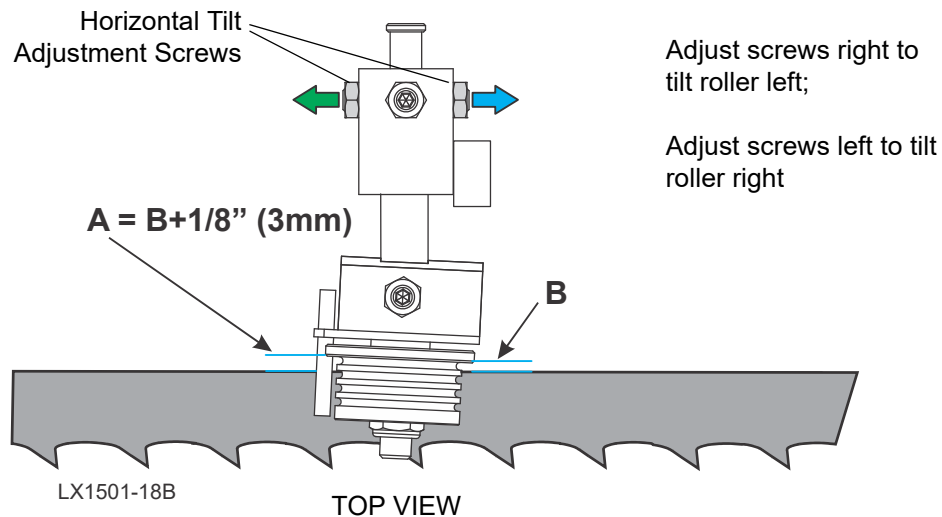

FIG. 8-6

2. Measure between the back edge of the blade and the blade guide roller at the left side of the blade guide ("A").
3. Measure between the back edge of the blade and the blade guide roller at the right side of the blade guide ("B").

The roller should be tilted slightly to the left ('A' 1/8" [3 mm] less than 'B' ±1/8" [3 mm]).

4. Loosen the jam nuts on the horizontal tilt adjustment screws.
 To tilt the roller left, loosen the right screw and tighten left screw. To tilt the roller right, loosen the left screw and tighten the right screw.
5. Tighten the jam nuts and recheck the tilt of the blade
6. Repeat the above steps for the other blade guide roller assembly.

Blade Guide Flange Spacing

Each blade guide must be adjusted so the roller flange is the correct distance from the back edge of the blade. If the flange is too close to or too far from the blade, the sawmill will not cut accurately.

NOTICE: When adjusting blade guide spacing, loosen the top set screw and one side set screw only. This will ensure horizontal and vertical tilt adjustments are maintained when the adjustment screws are retightened.

OUTER BLADE GUIDE

1. Ensure that the distance between the flange on the outer blade guide roller to the back edge of the blade measures to 1/8" (3.0 mm).
2. Adjust the roller back or forward if necessary.

See Figure 8-7.

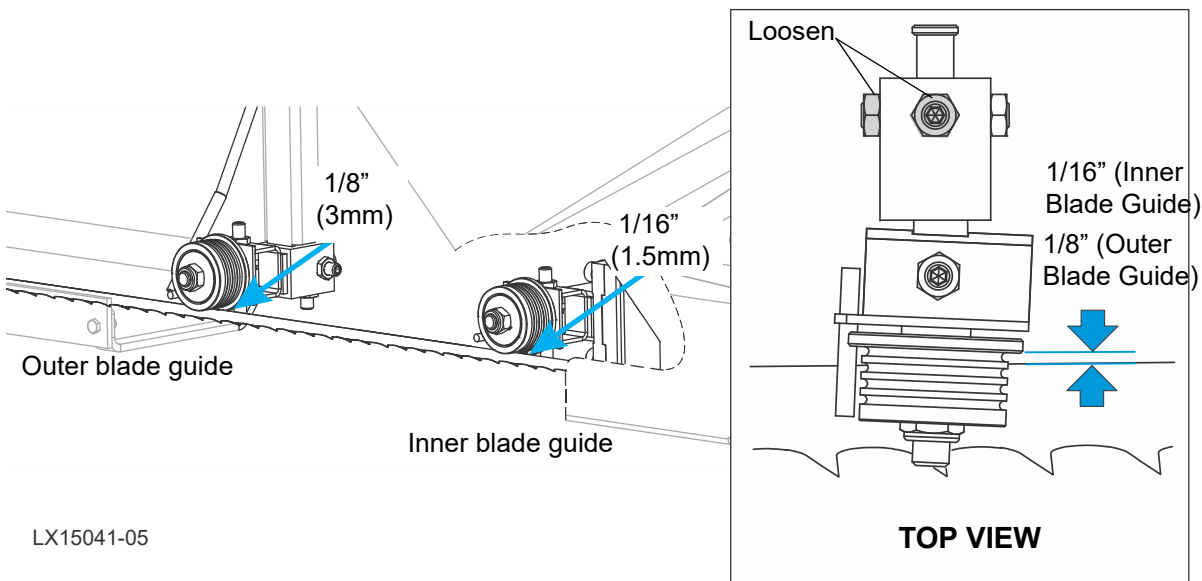

FIG. 8-7

3. Loosen the top screw and one side screw.
4. Gently tap the blade guide forward or backward until properly positioned.
5. Retighten the screws and jam nuts.

INNER BLADE GUIDE

6. Ensure that the distance between the flange on the outer blade guide roller to the back edge of the blade measures to 1/16" (1.5 mm).
7. Adjust the roller back or forward, as described above.

NOTE: Once the blade guides have been adjusted, any cutting variances are most likely caused by the blade. [See Blade Handbook, Form #600.](#)

Blade Height Scale Adjustment

After the entire sawmill has been aligned and all adjustments made, check that the blade height scale indicates the true distance from the blade to the bed rails.

1. Move the saw mast so the blade is positioned directly above one of the bed rails.
2. Measure from the bottom edge on a down-set tooth of the blade to the top of the bed rail, near the inner blade guide assembly.

If the scale does not indicate the actual distance from the blade to the bed rail when viewed level at the indicator, adjust the indicator.

See Figure 8-8.

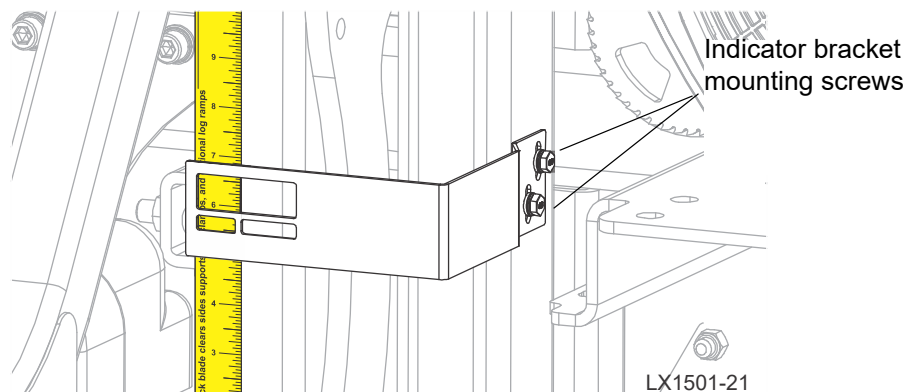

FIG. 8-8

3. Loosen the indicator bracket mounting screws.
4. Adjust the bracket up or down until the indicator is aligned with the correct mark on the scale (+0 -1/32 [0.8 mm]).
5. Retighten the indicator mounting screws.

For example, if the measurement from the down-set tooth of the blade to the bed rail was 14 3/4" (375 mm), make sure the indicator reads 14 3/4" (375 mm) on the scale.



Sawmill Alignment

Complete Alignment Procedure

8.2 Complete Alignment Procedure

The Complete Alignment procedure should be performed approximately every 1500 hours of operation (sooner if you regularly transport the sawmill over rough terrain).

NOTICE: The alignment procedures should be done in the order listed here, as each procedure builds on the previous procedure.

Frame Setup

Before performing the following alignment procedures, setup the mill on firm, level ground.

Level the frame and adjust the saw head.

Complete Blade Replacement

1. Open the sawhead and remove the saw blade.
2. Replace the blade wheel belts.

NOTE: New blade wheel belts are required to perform the complete alignment procedure.

3. Blow sawdust off of the blade guide assemblies and blade housings.
4. Remove the blade guide assemblies.

NOTE: To remove the blade guide assemblies and maintain the tilt adjustments, only loosen one side screw and the top screw. Leaving the other side screw and bottom screw in position will insure you will return the rollers to their original tilt adjustment.

5. Adjust the outer blade guide arm until the outer blade guide is approximately 24" from the inner blade guide.
6. Install a new blade and apply the appropriate tension.
7. Close the blade housing covers and make sure all persons are clear of the saw head.
8. Start the engine.
9. Engage the blade momentarily, rotating the blade until the blade positions itself on the wheels.



WARNING! Do not spin the blade wheels by hand. Spinning the blade wheels by hand may result in serious injury.

10. Disengage the blade.
11. Turn the engine off.

Blade Wheel Alignment

The blade wheels should be adjusted so they are level in the vertical and horizontal planes. If the blade wheels are tilted up or down, the blade will want to cut in the tilted direction. If the blade wheels are tilted horizontally, the blade will not track properly on the wheels.

DRIVE-SIDE BLADE WHEEL

1. Attach the Blade Guide Alignment Tool (p/n LTBGAT) to the blade as close to the wheel as possible without anything interfering with the tool.

NOTICE: Be sure the tool does not rest on a tooth or burr, and is lying flat against the bottom of the blade.

See Figure 8-9.

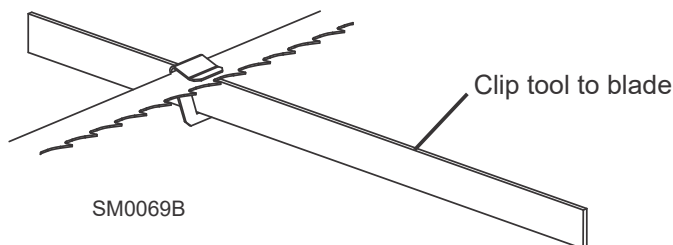

FIG. 8-9

2. Move the saw mast so the front end of the tool is positioned over the first bed rail.
3. Measure from the bottom of the tool to the top surface of the bed rail.
4. Move the saw mast so the rear of the tool is positioned over the bed rail.
5. Measure from the bottom of the tool to the top surface of the bed rail.
6. If the two measurements differ by more than 1/16" (1.5 mm), adjust the vertical tilt of the drive-side blade wheel.

See Figure 8-10.

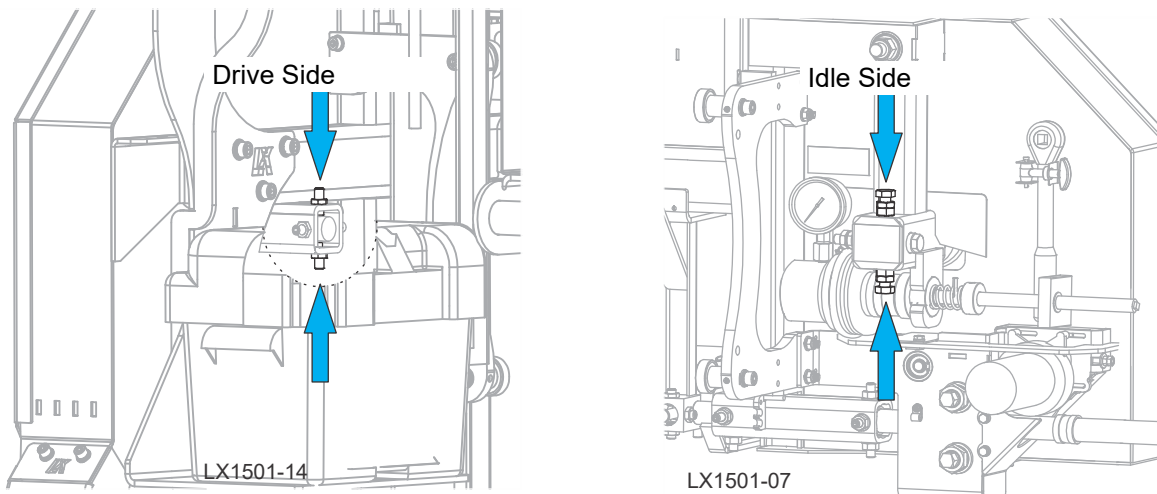

FIG. 8-10

7. Use the vertical adjustment screws to adjust the drive-side blade wheel.
 - 1). To tilt the wheel down, loosen the top adjustment screw one quarter turn.
 - 2). Loosen the jam nut on the bottom adjustment screw and tighten the screw.
 - 3). Tighten the top and bottom jam nuts.
 - 4). To tilt the wheel up, loosen the bottom adjustment screw one quarter turn.
 - 5). Loosen the jam nut on the top adjustment screw and tighten the screw.
 - 6). Tighten the top and bottom jam nuts
8. Recheck the vertical tilt of the drive-side blade wheel with the blade guide alignment tool.
9. Readjust the blade wheel as necessary until the front and rear of the tool are the same distance from the bed rail (within 1/16" [1.5 mm]).

IDLE-SIDE BLADE WHEEL

1. Move the blade guild arm fully to the right.
2. Remove the tool from the blade and reattach it as close to the idle-side wheel as possible without anything interfering with the tool.

3. Measure from the tool to the bed rail at both ends of the tool.
4. If the measurements at the front and rear ends of the tool differ by more than 1/16" (1.5 mm), adjust the vertical tilt of the idle-side blade wheel in the same manner as in Step 7.
5. Recheck the vertical tilt of the idle-side blade wheel with the blade guide alignment tool. Readjust the blade wheel as necessary until the front and rear of the tool are the same distance from the bed rail (within 1/16" [1.5 mm]).

BLADE TRACKING

6. Check the position of the blade on the idle-side blade wheel.

The horizontal tilt of the blade wheel should be adjusted so that the blade tracks with the gullet of an 1-1/4" blade at 1/8" (3 mm) out from the front edge of the wheel ($\pm 1/32$ [0.75 mm]).

See Figure 8-11.

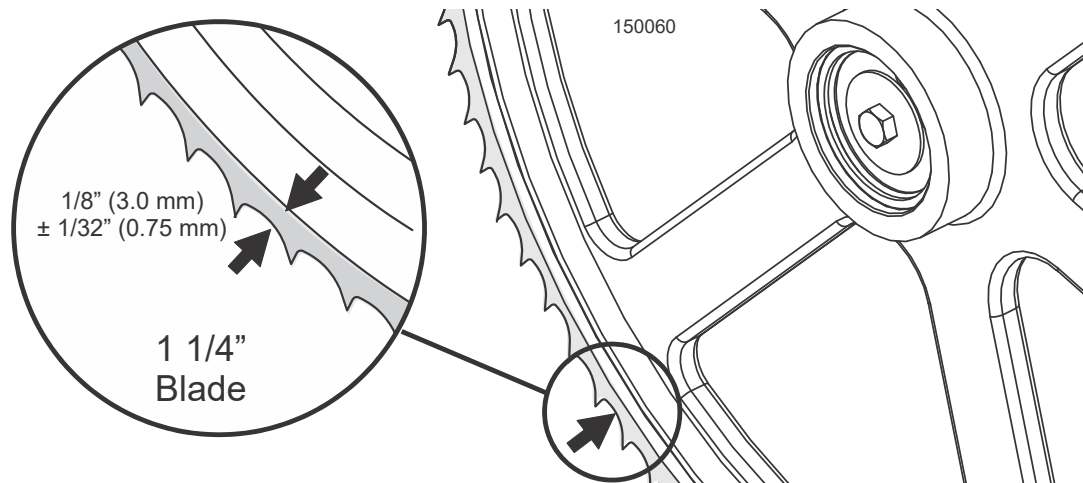

FIG. 8-11

7. Use the cant control adjustment to adjust the idle-side blade wheel.

If the blade is too far forward on the wheel, turn the cant control counterclockwise. If it is too far back on the wheel, turn the cant control clockwise.

See Figure 8-12.

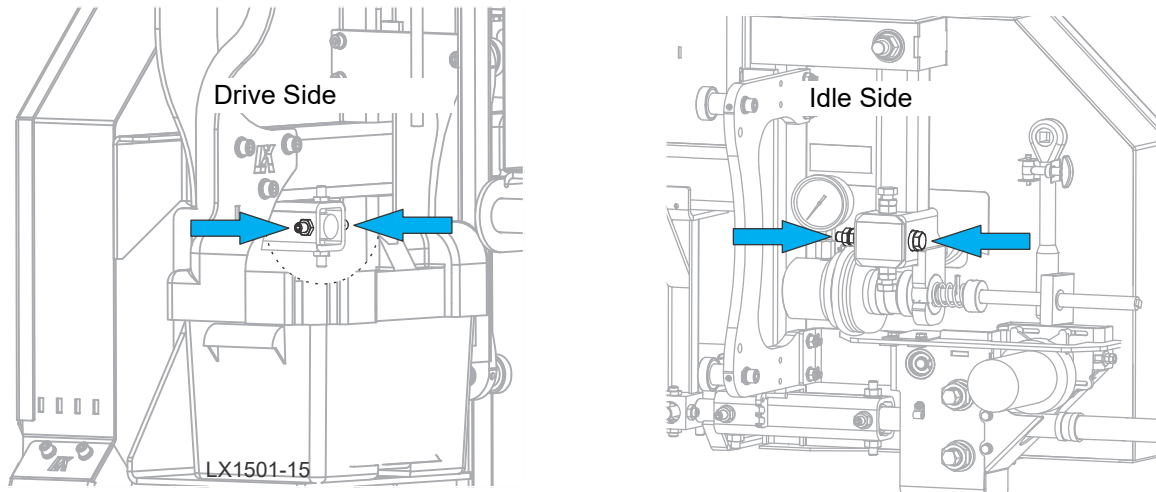

FIG. 8-12

8. If necessary, adjust the drive-side blade wheel to position the blade as shown in Figure 8-11.

NOTE: To move the blade back onto the blade drive wheel, loosen the right adjustment screw one quarter turn. Loosen the jam nut on the left adjustment screw and tighten the screw. Tighten the left and right jam nuts.

To move the blade out on the wheel, loosen the left adjustment screw one quarter turn. Loosen the jam nut on the right adjustment screw and tighten the screw. Tighten the left and right jam nuts.

Blade Guide Re-installation

NOTE: Before re-installing the blade guide assemblies, remove the blade guide adjusting screws and apply a lubricating oil such as 10W30 or Dexron III to each screw. This will prevent the screws and threaded holes from corroding and make screw adjustments easier.

1. Position outer blade guide assembly (with waterlube tube) to the mounting block on the blade guide arm so the that roller flange is **1/8" (3.0 MM)** from the blade.
2. Position the inner blade guide assembly to the mounting block on the saw head so that the roller flange is **1/16" (1.5 MM)** from the blade.
3. Tighten the two previously-loosened tilt adjustment screws to secure the blade guide assembly.

See Figure 8-13.

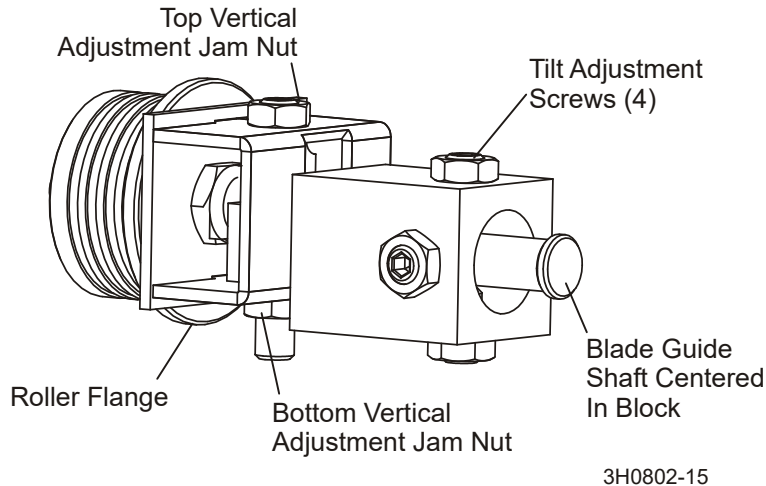

FIG. 8-13

4. Loosen the top vertical adjustment jam nut and tighten the bottom vertical adjustment jam nut to adjust the blade guide roller up so it **DOES NOT TOUCH THE BLADE**.

Blade Guide Arm Alignment

1. Inspect the blade guide arm for both looseness and parallel motion to the blade.

If the arm becomes loose, the blade guide will not deflect the blade properly, causing inaccurate cuts. A loose blade guide arm can also cause blade vibration

2. Open the blade guide arm to the widest position.
3. Use the inside top and bottom screws to adjust the arm up until the slide pad touches the saw head brace tube.
4. Tighten the jam nuts

8 Sawmill Alignment

Blade Guide Arm Alignment

See Figure 8-14. .

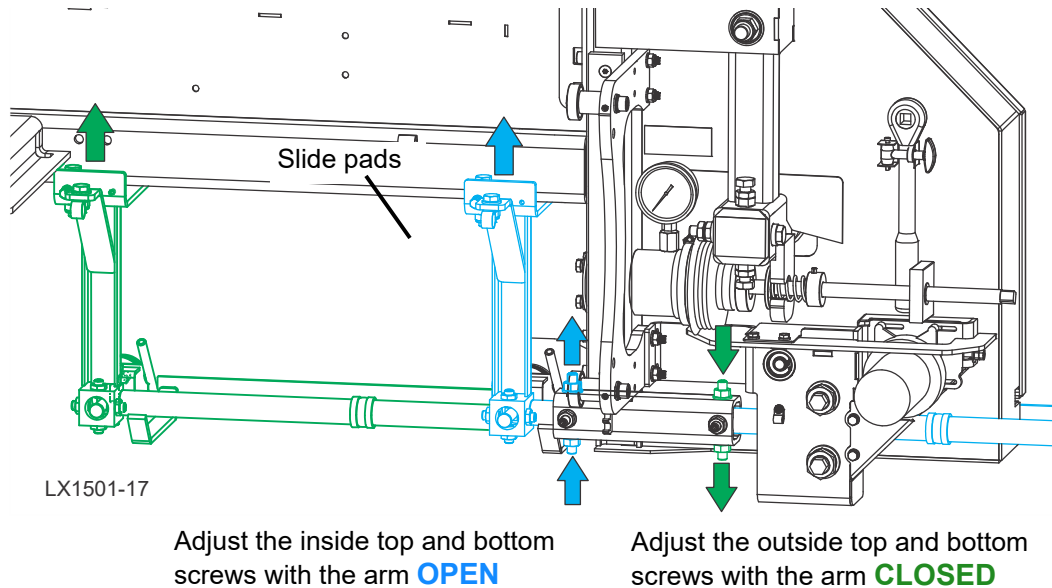

FIG. 8-14

5. Adjust the blade guide arm out to 1/2" (13 mm) from fully open.
6. Adjust the blade guide arm in all the way toward the other blade guide.
7. Use the outside top and bottom screws to adjust the arm up until the slide pad touches the saw head brace tube. Tighten the jam nuts.

NOTICE: When adjusting the blade guide arm screws, be careful not to tighten the screws too much or put the arm in a bind. Operate the blade guide arm to ensure the arm moves easily in and out.

8. With the blade guide arm still all the way in toward the other blade guide, tighten all the side screws until they touch the arm.
9. Back the screws off 1/4 turn and tighten the jam nuts.

See Figure 8-15.

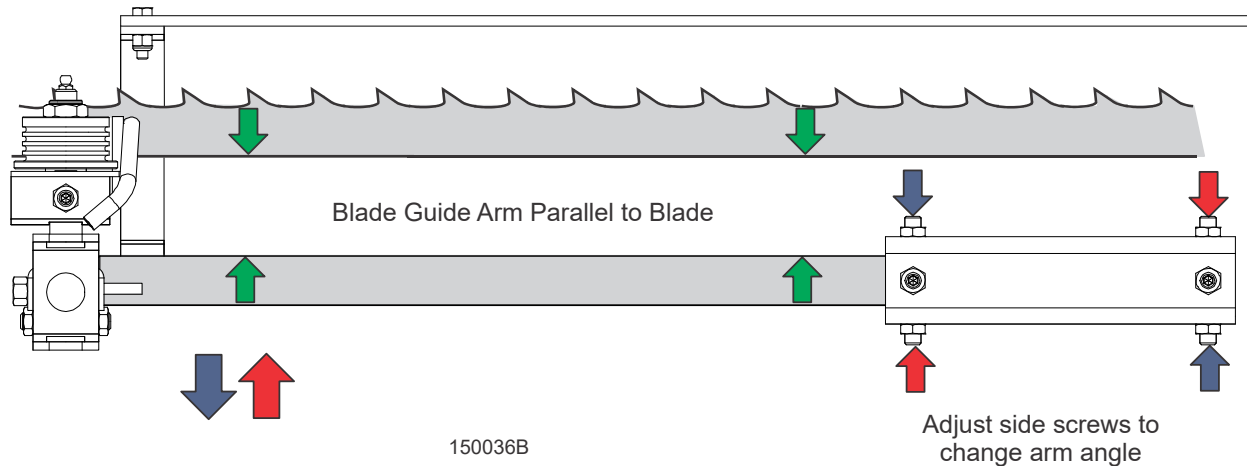

FIG. 8-15

10. Measure the distance between the blade guide arm and back edge of the blade.
11. Adjust the appropriate side screws on the blade guide arm housing so the arm measures the same distance from the blade at both ends of the arm.
12. To move the blade guide end of the arm toward the **FRONT** of the sawmill, loosen jam nuts on the front inside screw and the rear outside screw in order to turn the screws counterclockwise one full turn and tighten the jam nuts.
13. Loosen the jam nuts on the front outside screw and the rear inside screw in order to turn the screws clockwise until they touch the arm, back off 1/4" turn, and tighten the jam nuts.
14. To move the blade guide end of the arm toward the **REAR** of the sawmill, loosen jam nuts on the front outside screw and the rear inside screw in order to turn the screws counterclockwise one full turn and tighten the jam nuts.
15. Loosen the jam nuts on the front inside screw and the rear outside screw. Turn the screws clockwise until they touch the arm, back off 1/4" turn, and tighten the jam nuts.

Blade Guide Deflection

Perform the following steps to achieve proper blade deflection with the blade guides.

1. Raise the saw head until the blade is 15" (375 mm) above a bed rail. Measure the actual distance with a tape from the top of the rail to the bottom of the blade.
2. Make sure the two vertical adjustment set screws are threaded into the blade guide shaft until they touch each other.

See Figure 8-16.

Loosen the bottom jam nut and tighten the top jam nut until the blade guide deflects the blade down until the bottom of the blade measures 14 3/4" (370 mm) from the bed rail.

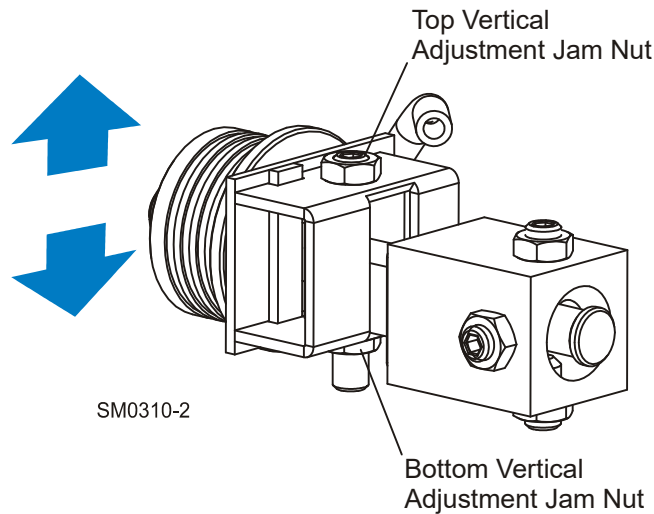
**FIG. 8-16**

3. Repeat for the other blade guide.

NOTE: Be sure that the blade guide deflector rod clears the blade on both guide assemblies. The rod on the outer guide assembly should be checked with the arm all the way in and all the way out.

Blade Guide Vertical Tilt Alignment

The blade guides should be adjusted properly in the vertical plane. If the blade guides are tilted vertically, the blade will try to travel in the tilted direction.

A Blade Guide Alignment Tool (BGAT) is provided to help you measure the vertical tilt of the blade.

1. Open the adjustable blade guide arm 1/2" (13 mm) from full open.
2. Clip the alignment tool on the blade. Position the tool close to the outer blade guide assembly. Be sure the tool does not rest on a tooth or burr, and is lying flat against the bottom of the blade.

See Figure 8-17.

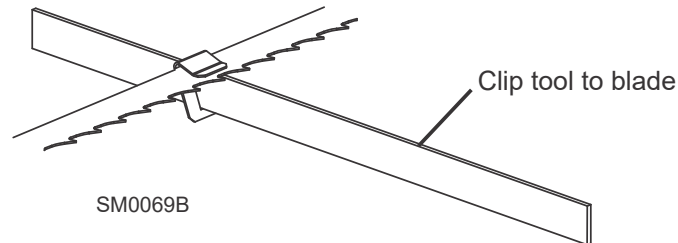

FIG. 8-17

3. Move the mast so that the front end of the tool is positioned above the bed rail. Measure the distance from the bed rail to the bottom edge of the tool.
4. Move the mast so that the back end of the tool is positioned above the bed rail. Measure the distance from the bed rail to the bottom edge of the tool.
5. If the measurement from the tool to the bed rail is not equal within 1/32" (.75 mm), adjust the vertical tilt of the outer blade guide roller.

See Figure 8-18.

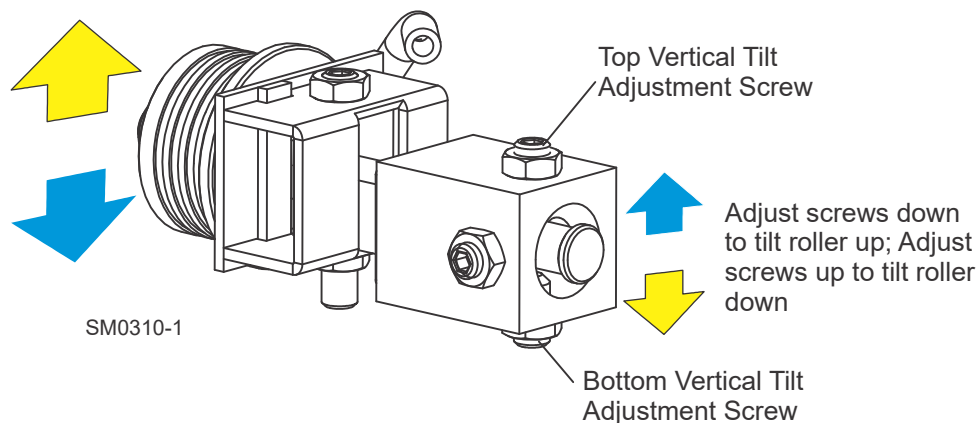

FIG. 8-18

6. Loosen one set screw at the side of the blade guide assembly.
7. Loosen the jam nuts on the top and bottom vertical tilt adjustment screws.

To tilt the roller up, loosen the bottom screw and tighten top screw. To tilt the roller down, loosen the top screw and tighten the bottom screw.

8. Tighten the jam nuts and recheck the tilt of the blade.

9. Move the blade guide alignment tool close to the inner blade guide roller assembly and repeat the above steps. Adjust the vertical tilt of the inner blade guide if necessary.

Blade Guide Flange Spacing

Each blade guide must be adjusted so the roller flange is the correct distance from the back edge of the blade. If the flange is too close to or too far from the blade, the sawmill will not cut accurately.

NOTICE: When adjusting blade guide spacing, loosen the top set screw and one side set screw only. This will ensure horizontal and vertical tilt adjustments are maintained when the adjustment screws are retightened.

OUTER BLADE GUIDE

1. Ensure that the distance between the flange on the outer blade guide roller to the back edge of the blade measures to 1/8" (3.0 mm).
2. Adjust the roller back or forward if necessary.

See Figure 8-19.

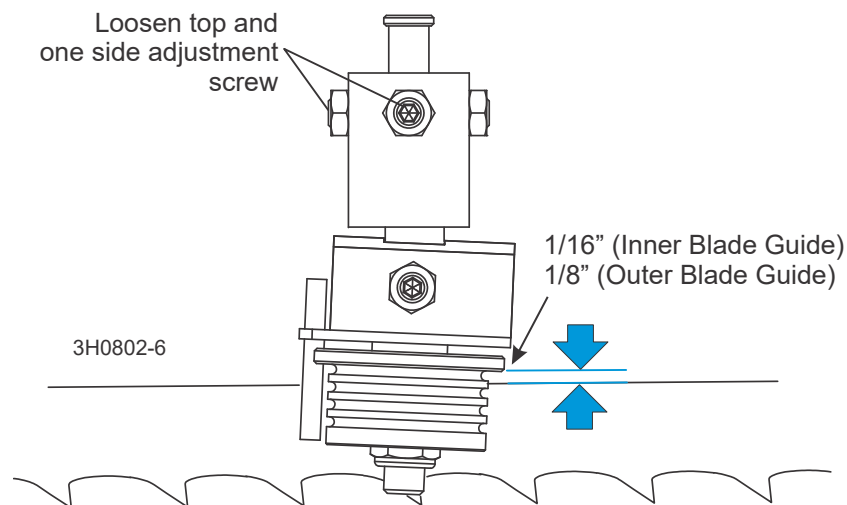

FIG. 8-19

3. Loosen the top screw and one side screw.
4. Gently tap the blade guide forward or backward until properly positioned.
5. Retighten the screws and jam nuts.

INNER BLADE GUIDE

6. Ensure that the distance between the flange on the outer blade guide roller to the back edge of the blade measures to 1/16" (1.5 mm). (See Figure 8-19.)
7. Adjust the roller back or forward, as described above.

Blade Height Scale Adjustment

After the entire sawmill has been aligned and all adjustments made, check that the blade height scale indicates the true distance from the blade to the bed rails.

1. Move the saw mast so the blade is positioned directly above one of the bed rails.
2. Measure from the bottom edge on a down-set tooth of the blade to the top of the bed rail, near the inner blade guide assembly.
3. If the scale does not indicate the actual distance from the blade to the bed rail when viewed level at the indicator, adjust the indicator.

See Figure 8-20.

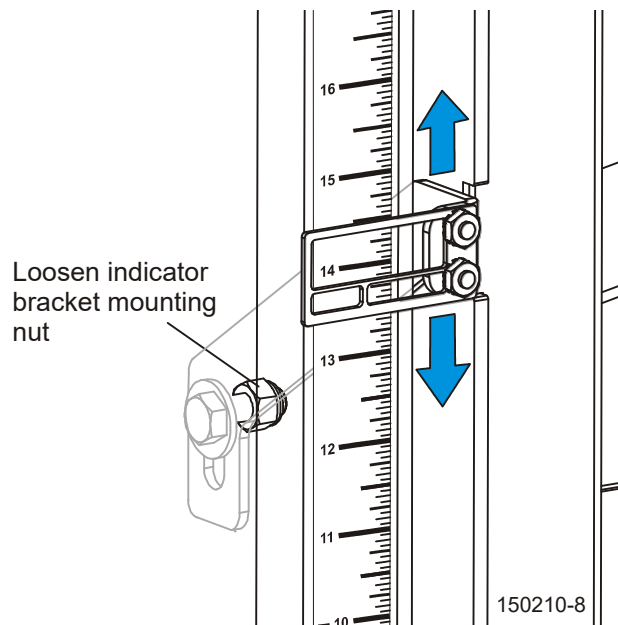

FIG. 8-20

4. Loosen the indicator bracket mounting nut.
5. Adjust the bracket up or down until the indicator is aligned with the correct mark on the scale (+0 -1/32 [0.8 mm]).



Sawmill Alignment

Blade Height Scale Adjustment

6. Retighten the indicator mounting nut.

For example, if the measurement from the down-set tooth of the blade to the bed rail was 14 3/4" (375 mm), make sure the indicator reads 14 3/4" (375 mm) on the scale.

INDEX

A

assembly
 battery 3-14
 bed sections 3-1
 sawdust deflector 3-14

B

blade
 breakage, troubleshooting 7-1

blade guide arm
 operation 5-6

C

chain
 maintenance 6-5
 up/down tension 6-8

clutch/brake lever
 operation 5-3

L

leveling logs 5-5

loading logs 5-4

M

maintenance
 blade guide 6-1
 blade wheel belts 6-6
 carriage track/wipers 6-4
 drive belt 6-6
 mast rails 6-5
 miscellaneous 6-5
 part wear life 6-1
 sawdust removal 6-3
 up/down 6-8

O

operation
 edging 5-8
 sawing 5-7

P

power feed
 operation 5-2
 speed adjustment 5-1, 5-2

S

safety
 instructions 2-5
 lockout procedure 2-11
 symbols 2-5

scale
 blade height operation 5-9
 inch height 5-9
 quarter inch 5-9

service information
 general contact info 1-1

T

troubleshooting 7-1
 sawing problems 7-1

turning logs 5-4

U

up/down
 operation 5-6

W

water lube
operation 5-10