

**Pallet Dismantler
Safety, Operation,
Maintenance & Parts Manual**

**Electric Center Drop Table Models rev.A2.08
PD200ECDT**

Safety is our #1 concern!

Form #2316

Models Effected:

PD200A10-CUW72

PD200A10-CUW84

PD200B10-CU

PD200B10-CU-HS

PD200B10-CUW72

PD200B10-CUW84

PD200C10-CU

PD200C10-CU-HS

PD200C10-CUW72

PD200C10-CUW72-HS

PD200C10-CUW84



**WARNING! Read and understand this
manual before using this machine.**

California

Proposition 65 Warning



WARNING: Drilling, sawing, sanding or machining wood products can expose you to wood dust, a substance known to the State of California to cause cancer. Avoid inhaling wood dust or use a dust mask or other safeguards for personal protection.

For more information go to **www.P65Warnings.ca.gov/wood**.

Active Patents assigned to Wood-Mizer, LLC

Wood-Mizer, LLC has received patents that protect our inventions which are a result of a dedication to research, innovation, development, and design. Learn more at: woodmizer.com/patents

©2023 Wood-Mizer LLC

Printed in the United States of America, all rights reserved. No part of this manual may be reproduced in any form by any photographic, electronic, mechanical or other means or used in any information storage and retrieval system without written permission from

Wood-Mizer, LLC

8180 West 10th Street

Indianapolis, Indiana 46214

SECTION 1 INTRODUCTION

1.1 About this manual 1-1
1.2 Specifications 1-2

SECTION 2 GENERAL SAFETY

2.1 Safety symbols 2-1
2.2 Electrical Lockout Procedures 2-2

SECTION 3 SETUP AND OPERATION

3.1 Site Preparation 3-1
3.2 Onsite setup 3-1
3.3 Operation 3-1
 One-person operation 3-1
 Two-person operation 3-3

SECTION 4 MAINTENANCE

4.1 General maintenance after each use 4-1
4.2 Tracking the blade 4-1
4.3 Changing the blade 4-2
4.4 Remove the drive hub 4-3

SECTION 5 REPLACEMENT PARTS

5.1 How To Use The Parts List 5-1
 To Order Parts 5-1
5.2 Pallet Dismantler Assembly 5-2
5.3 Pallet Dismantler Parts (Drive Side) 5-3
5.4 Motors 5-5
5.5 Pallet Dismantler Parts (Idle Side) 5-6
5.6 Pallet Dismantler Table Parts 5-8
5.7 Table Control Assembly 5-10
5.8 Motor Control Assembly 5-11
5.9 Blade Guide Assembly 5-13
5.10 Decals 5-14
5.11 Trailer Front (Optional) 5-16
5.12 Trailer Rear (Optional) 5-17

Wood-Mizer® LLC Limited Product Warranty



Wood-Mizer LLC ("Warrantor"), an Indiana corporation with its principal place of business at 8180 West Tenth Street, Indianapolis, IN 46214-2400 USA, warrants to the purchaser ("Purchaser") that for the time periods specifically stated herein and subject to the terms, conditions and limitations stated herein, the equipment manufactured by the Warrantor will be free from defects in material and workmanship attributable to Warrantor so long as, during the warranty periods stated herein, the equipment is installed, operated and maintained in accordance with the instructions provided by Warrantor.

PRODUCT	MODEL CLASS	LENGTH OF WARRANTY		EFFECTIVE DATE
		USA & CANADA	NON USA & CANADA	
Portable Sawmills, Resaws, Edgers	LT, LX, HR, EG	Two years	One year	Date of purchase
Portable Sawmills with Chassis	LT28, LT35, LT40, LT50, LT70, LX450	Two years, excluding the chassis, which chassis shall have a five year warranty	One year	
Industrial Sawmills, Resaws, Edgers	WM, HR, EG, TVS, SVS	One year	One year	Date of purchase or date of installation / training (if applicable), whichever occurs first, not to exceed 6 months from date of purchase
TITAN Industrial	WB, TV, HR, EG, EA, MR	One year	One year	
Material Handling	TWC, IC, TD, LD, GC, CR, CB, CC	One year	One year	
Blade Maintenance Equipment	BMS, BMT, BMST	One year	One year	Date of purchase
Options and Accessories	Various	One year*	One year*	
Moulders, Extractors	MP, MD	Two years	One year	
Kilns	KS, KD	One year	One year	
Slab Flattener	MB	Two years	One year	
Pallet Equipment	PD, PC	One year	One year	
Log Splitters	FS	One year	One year	
Replacement Parts	Various	90 days	90 days	

* Warranty on Options will match the warranty on the primary equipment when purchased on same invoice.

Exclusions from 90 Day, Limited One Year and Two Year Warranty

Warrantor shall have no responsibility under this warranty for any wear components, including, but not limited to: belts, blade guides, blades, electric motor brushes, drum switches, filters, fuses, hoses, bearings (excluding cylindrical drive bearings), bushings, cable carriers, and spark plugs. All wear components are furnished "as is", without any warranty from Warrantor. This limited warranty does not cover any defects caused by misuse, negligence, alterations, damage due to overload, abnormal conditions, excessive operation, accident, or lack of performance of normal maintenance services.

Several components which are used in the manufacture of the equipment but not manufactured by Warrantor such as cant hooks, power plants, laser sights, batteries, tires, and trailer axles have warranties provided by the original equipment manufacturer (written copies available upon request). Warrantor does not separately warrant such items. Components or equipment manufactured by third parties are not covered by this warranty. Warrantor, however, will provide reasonable assistance to the Purchaser to make claims against any warranties applicable to such component parts as provided by such original equipment manufacturers. Components or equipment manufactured by third parties are not covered by this Warranty.

Five Year Limited Chassis Warranty

The limited five year chassis warranty described above, DOES NOT extend to (a) any damage stemming from accident, improper towing, overload, abuse, misuse, abnormal conditions, negligence, excessive operation, or lack of maintenance, (b) rust caused by exposure to corrosive atmospheric conditions, or (c) the sawmill head, carriage, axle, brakes, or any hydraulic or electrical components attached to the chassis.

Warrantor's Obligations as To Defects

In the event that the equipment fails to perform due to defective materials or workmanship attributable to Warrantor under normal use and service within the established warranty period, Purchaser's sole and exclusive remedy and Warrantor's sole liability shall be to replace or repair, in Warrantor's sole and subjective discretion, any defective part at Warrantor's principal place of business without cost to the Purchaser if such defect exists. The determination of whether a product is defective shall be made by Warrantor in Warrantor's sole and subjective discretion. The Purchaser must notify Warrantor prior to shipping any defective part. Warrantor, at its sole discretion, may cover expenses incurred in shipping the defective part to Warrantor for evaluation; provided, however, that Warrantor will not be responsible for labor, travel time, mileage, removal, installation or incidental or consequential damages. However, any part in excess of 140 pounds must be returned by the Purchaser, to the Warrantor's nearest authorized facility at the Purchaser's expense, if return is requested by Warrantor. Warrantor shall have a reasonable time within which to replace or repair the defective part. If Warrantor determines that the product is not defective under the terms of this warranty in Warrantor's sole and subjective discretion, then Purchaser shall be responsible for any expenses incurred by Warrantor in returning the equipment to the Purchaser.

Limitations and Disclaimers of Other Warranties

EXCEPT FOR THE EXPRESS WARRANTY PROVISIONS STATED ABOVE, WARRANTOR DISCLAIMS ALL WARRANTIES, EXPRESS AND/OR IMPLIED, INCLUDING WITHOUT LIMITATION, THE IMPLIED WARRANTIES OF MERCHANTABILITY, AND FITNESS FOR A PARTICULAR PURPOSE, NON-INFRINGEMENT AND TITLE. No representation or other affirmation of fact by representatives of Warrantor, whether verbal or in writing, including photographs, brochures, samples, models, or other sales aids, shall constitute a warranty or other basis for any legal action against Warrantor. There are no other representations, promises, agreements, covenants, warranties, guarantees, stipulations or conditions, express or implied, by Warrantor except as expressly set forth herein. THE ORIGINAL PURCHASER AND ANY INTENDED USER OR BENEFICIARY OF THIS EQUIPMENT, SHALL NOT BE ENTITLED TO RECOVER ANY INDIRECT, SPECIAL, PUNITIVE, EXEMPLARY, CONSEQUENTIAL, SPECIAL, OR INCIDENTAL DAMAGES OR LOSSES, INCLUDING BUT NOT LIMITED TO, DAMAGES OF LOST PRODUCTION, LOST REVENUE, LOST PRODUCT, LOST PROFITS, LOST BUSINESS, LOSS OF USE, LOSS OF GOODWILL, OR BUSINESS INTERRUPTION, FROM WARRANTOR FOR ANY REASON WHATSOEVER INCLUDING WITHOUT LIMITATION WARRANTY OR DEFECT IN THE PRODUCT REGARDLESS OF THE SOLE, JOINT AND/OR CONCURRENT NEGLIGENCE, BREACH OF CONTRACT, BREACH OF WARRANTY, STRICT LIABILITY IN TORT OR STATUTORY CLAIMS OR OTHER LEGAL FAULT OR RESPONSIBILITY OF EITHER WARRANTOR OR PURCHASER OR ITS EMPLOYEES OR AGENTS. Warrantor does not warrant that its equipment meets or complies with the requirements of any particular safety code or governmental requirements.

Defective items replaced under the terms of this warranty become the property of Warrantor.

Design Changes

Warrantor reserves the right to change the design of its products from time to time without notice and without obligation to make corresponding changes in or to its products previously manufactured.

Rights of Purchasers

The validity and effect of this limited warranty as well as its interpretation, operation and effect, shall be determined exclusively by the principles of law and equity of the State of Indiana, USA. This limited warranty gives Purchaser specific legal rights. Purchaser may also have other rights, which may vary from state to state. Some states may not allow limitations as to the duration of implied warranties or to the exclusion or limitation of incidental or consequential damages, so some of the limitations and exclusions detailed set forth above may not apply. In the event that any one or more of the provisions of this warranty shall be or become invalid, illegal or unenforceable in any respect, the validity, legality and enforceability of the remaining provisions of this warranty shall not be affected thereby.

Interpretations

This Warranty constitutes the entire warranty agreement between Warrantor and Purchaser and supersedes any prior understandings or agreements pertaining to the same subject matter. This warranty cannot be amended except in writing which refers to this warranty which is signed by both Warrantor and Purchaser.

SECTION 1 Introduction

1.1 About this manual

Congratulations on your purchase of a Wood-Mizer Pallet Dismantler! When properly maintained and operated, your pallet dismantler should give you many years of dependable service.



CAUTION! Read this entire manual before operating the equipment. Take notice of all safety warnings throughout this manual and those posted on the equipment. Keep this manual with this equipment at all times, regardless of ownership.



Read all additional manufacturer's manuals and observe any applicable safety instructions including dangers, warnings, and cautions.

Only persons who have read and understood the entire operator's manual should operate the Wood-Mizer Pallet Dismantler. The pallet dismantler is not intended for use by or around children.

1.2 Specifications

Machine Dimensions:

Length:	10.5 ft (3.2 m), 11 ft, (3.35 m) 11.5 ft (3.50 m)
Width:	5 ft (1.5 m),
Height:	4 ft (1.2 m)
Weight:	1,800 lbs (820 k)

Material Handling:

Standard (S)	60" (1.52 m)
Wide (SW)	66" (1.68m)
72 (S72)	72" (1.83m)

Power:

PD200A10	230v 1ph 10hp
PD200B10	230v 3ph 10hp
PD200C10	460v 3ph 10hp

Blade:

Top speed	2,200 fpm (670 m/min)
Material	Bi-metal
Size:	1-1/4" x 0.042 thick
Life expectancy:	1,200 pallet or 3 days production
Teeth:	5-8 variable teeth per inch

Air Pressure:

Min:	80 psi (5.6 Kg/cm)
Max:	120 psi (8.4 Kg/cm)

Drive Wheels:

Hub size:	15"- 6 lugs x 5.5 bolt circle inch
Tire size:	ST205/75D-15 bias ply only

SECTION 2 General Safety

OWNER'S RESPONSIBILITY

NOTICE It is always the **owner's responsibility** to comply with all applicable safety instructions, as well as federal, state and local laws, rules and regulations regarding the ownership and operation equipment. All owners should be thoroughly familiar with all applicable safety instructions and laws and comply with them fully while using or transporting the equipment.



WARNING! Clean sawdust from all guards, vents, control boxes, or any area where sawdust may gather **after every shift**. Failure to do so may result in fire.



NOTE: ONLY safety instructions regarding **personal injury** are listed in this section. Safety instructions regarding only equipment damage appear where applicable throughout the manual.

2.1 Safety symbols

The following symbols and signal words call your attention to instructions concerning your personal safety. Be sure to observe and follow these instructions.



DANGER! indicates an imminently hazardous situation which, if not avoided, will result in death or serious injury.



WARNING! suggests a potentially hazardous situation which, if not avoided, could result in death or serious injury.



CAUTION! refers to potentially hazardous situations which, if not avoided, may result in minor or moderate injury or damage to equipment.

NOTICE indicates vital information.

NOTE: gives helpful information.

OBSERVE SAFETY INSTRUCTIONS

NOTICE

- Keep children away from the area.
- Read the entire operator's manual before operating the equipment.
- Take notice of all safety warnings throughout this manual and those posted on the machine.
- Keep this manual with this machine at all times, regardless of ownership.
- Read all additional manufacturer's manuals.
- Obey all applicable safety instructions including dangers, warnings, and cautions.
- Only persons who have read and understood the entire operator's manual should operate the equipment.



WEAR SAFETY CLOTHING



WARNING! Secure all loose clothing and jewelry before operating the equipment.

Always wear hand, eye, ear, and foot protection when operating or servicing the equipment.

EQUIPMENT SETUP



DANGER! Do not operate the equipment without all covers and guards in place.



WARNING! Set up the equipment on solid, level ground.

Check that the tire pressures are between 50-55 psi.

KEEP HANDS AWAY



DANGER! Keep hands 12" away from the blade.

Remove power before clearing debris or any other maintenance activity.



WARNING! Avoid contact with any hot parts (engines or motors).

Allow the system to cool sufficiently before beginning any service function, including debris removal.

Avoid contact with sharp edges of the cutting blade.



KEEP EQUIPMENT AND AREA AROUND EQUIPMENT CLEAN

 **DANGER!** Maintain a clean and clear path for all necessary movement around the equipment and stacking areas.

 **WARNING!** Do not allow children in the area of the equipment. Failure to do so may result in death or serious injury

DISPOSE OF WOOD BY-PRODUCTS PROPERLY

NOTICE Properly dispose of all wood by-products, including sawdust, chips, and other debris, including operation waste such as coolant, oil, fuel, oil filters, fuel filters, etc.

KEEP SAFETY LABELS IN GOOD CONDITION

NOTICE Ensure that all safety decals are clean and readable. Replace all damaged safety decals to prevent personal injury or damage to the equipment. Contact your local distributor, or call your Customer Service Representative to order more decals.

If replacing a component that has a safety decal affixed to it, ensure the new component also has the safety decal affixed.

2.2 Electrical Lockout Procedures

RULES FOR USING LOCKOUT PROCEDURE

The equipment shall be locked out to protect against accidental or inadvertent operation when such operation could cause injury to personnel. Do not attempt to operate any switch or valve bearing a lock.

LOCKOUT PROCEDURES MUST BE USED DURING, BUT NOT LIMITED TO:

- Changing or adjusting blades
- Unjamming operations
- Cleaning
- Mechanical repair
- Electrical maintenance
- Retrieval of tools/parts from work area
- Activities where guards or electrical panel guard is open or removed

MAINTENANCE HAZARDS INCLUDE, BUT NOT LIMITED TO:

- Blade contact
- Pinch points
- Kickbacks
- Missiles (thrown blades/wood chips)
- Electrical

FAILURE TO LOCKOUT MAY RESULT IN, BUT NOT LIMITED TO:

- Cut
- Crush
- Blindness

- Puncture
- Electrocution
- Serious injury and death
- Amputation
- Burn
- Shock

TO CONTROL MAINTENANCE DANGERS:

- Lockout procedures must be followed (see **OSHA regulation 1910.147**).
- Never rely on machine stop control for maintenance safety (emergency stops, on/off buttons, interlocks).
- Do not reach into moving blades or feed systems. Allow all coasting parts to come to a complete stop.
- Electrical power supply and air supply must both be locked out.
- Where established lockout procedures cannot be used (electrical troubleshooting or mechanical dynamic troubleshooting), alternative effective protective techniques shall be employed which may require special skills and planning.
- Always follow safe operations practices in the workplace.

EQUIPMENT LOCKOUT PROCEDURE

Lockout procedures per OSHA regulation 1910.147, appendix A:

GENERAL

The following simple lockout procedure is provided to assist owner/operators in developing their procedures so they meet the requirements of **OSHA regulation 1910.147**. When the energy isolating devices are not lockable, tagout may be used, provided the owner/operator complies with the provisions of the standard which require additional training and more rigorous periodic inspections. When tagout is used and the energy isolating devices are lockable, the owner/operator must provide full operator protection (see OSHA regulation 1910.147, paragraph (c)(3)) and additional training and more rigorous periodic inspections are required. For more complex systems, more comprehensive procedures may need to be developed, documented, and utilized.

PURPOSE

This procedure establishes the minimum requirements for the lockout of energy isolating devices whenever maintenance or servicing is done on machines or equipment. It shall be used to ensure that the machine or equipment is stopped, isolated from all potentially hazardous energy sources and locked out before personnel perform any servicing or maintenance where the unexpected energization or start-up of the machine or equipment or release of stored energy could cause injury.

COMPLIANCE WITH THIS PROGRAM

All personnel are required to comply with the restrictions and limitations imposed upon them during the use of lockout. The authorized personnel are required to perform the lockout in accordance with this procedure. All operators, upon observing a machine or piece of equipment which is

locked out to perform servicing or maintenance shall not attempt to start, energize, or use that machine or equipment.

SEQUENCE OF LOCKOUT

1. Notify all affected personnel that servicing or maintenance is required on a machine or equipment and that the machine or equipment must be shut down and locked out to perform the servicing or maintenance.
2. The authorized employee shall refer to the company procedure to identify the type and magnitude of the energy that the machine or equipment utilizes, shall understand the hazards of the energy, and shall know the methods to control the energy.
3. If the machine or equipment is operating, shut it down by the normal stopping procedure (depress the stop button, open switch, close valve, etc.).
4. De-activate the energy isolating device(s) so that the machine or equipment is isolated from the energy source(s).
5. Lock out the energy isolating device(s) with assigned individual lock(s).
6. Stored or residual energy (such as that in capacitors, springs, elevated machine members, rotating flywheels, hydraulic systems, and air, gas, steam, or water pressure, etc.) must be dissipated or restrained by methods such as grounding, repositioning, blocking, bleeding down, etc.
7. Ensure that the equipment is disconnected from the energy source(s) by first checking that no personnel are exposed, then verify the isolation of the equipment by operating the push button or other normal operating control(s) or by testing to make certain the equipment will not operate.



CAUTION! Return operating control(s) to neutral or "off" position after verifying the isolation of the equipment.

8. The machine or equipment is now locked out.

RESTORING EQUIPMENT TO SERVICE

When the servicing or maintenance is completed and the machine or equipment is ready to return to normal operating condition, the following steps shall be taken.

1. Check the machine or equipment and the immediate area around the machine to ensure that nonessential items have been removed and that the machine or equipment components are operationally intact.
2. Check the work area to ensure that all personnel have been safely positioned or removed from the area.
3. Verify that the controls are in neutral.
4. Remove the lockout devices and re-energize the machine or equipment.

NOTE: The removal of some forms of blocking may require re-energization of the machine before safe removal.

5. Notify affected personnel that the servicing or maintenance is completed and the machine or equipment is ready for use.

PROCEDURE INVOLVING MORE THAN ONE PERSON

In the preceding steps, if more than one individual is required to lock out the equipment, **each shall place his own personal lock on the energy isolating devices.**

SECTION 3 SETUP AND OPERATION

3.1 Site Preparation

An outside source of compressed air adjustable from 80-120 psi (5.6-8.4 Kg/cm) is required.



WARNING! Have a certified electrician install the power to your machine.

Be sure the power supply cables are not a trip hazard.



CAUTION! Improper voltage will cause damage to the motor and electronic components. Have a qualified electrician install the power supply to begin using your pallet dismantler.

NOTICE The power supply must meet the motor specifications concerning wire size, fused disconnect, and voltage, which are provided in the motor's manual. The electrical installation must also meet local codes.

NOTICE Ensure the blade spins in the proper direction. If not, have the electrician change the engine rotation.

3.2 Onsite setup



DANGER! Maintain a clean and clear path for all necessary movement around the pallet dismantler and stacking areas.



WARNING! Do not allow children in the area of the pallet dismantler.

Do not set up the pallet dismantler on ground with more than a 10 degree incline.

3.3 Operation



DANGER! Keep hands 12" away from the blade.



WARNING! Do not load pallets greater than 60" (1.5 m).

Avoid contact with sharp edges of the cutting wedges.

Check that the tire pressures are between 50-55 psi.

One-person operation

NOTICE Before starting, ensure the blade is tensioned properly. Failure to do so may result in drive wheel tire damage.



6. Tighten the tension by ratcheting the device handle until the pivot arm is touching the stop bolt.

NOTE: If a new blade is required see [Section 4.3 Changing the blade.](#)

7. Remove the pass back bars from the table top by unpinning them and slide them out.
8. Momentarily (approximately 15 seconds) run the blade on the drive wheels.
9. Turn off disconnect.
10. Open the wheel covers to inspect the blade tracking.

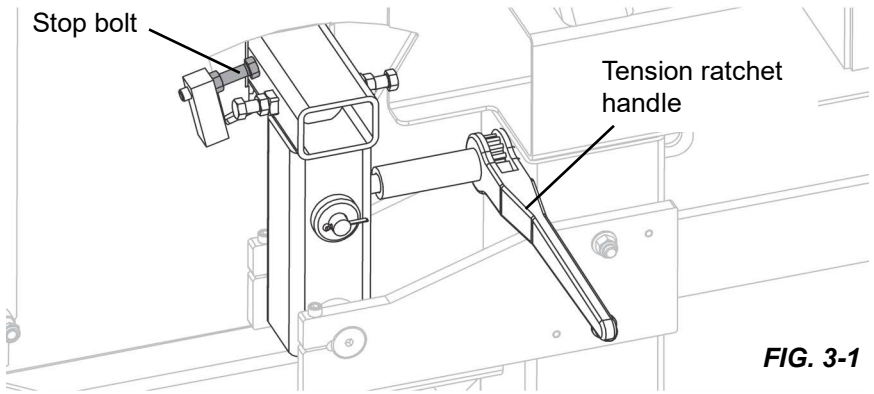

FIG. 3-1

NOTE: If the blade is not tracking in the center of the tire, refer to [Section 4.2 Tracking the blade.](#)

11. When the blade is tracking properly, close the wheel covers and turn on the disconnect.
12. Start the blade.
13. Use the air valve to adjust the table approximately one board thickness plus 1/4 inch (6 mm) below the blade.

Air valve controls: Neutral is the 3 o'clock position. Raise the handle up to raise the table; lower handle to lower table. Always return the handle to the neutral position.

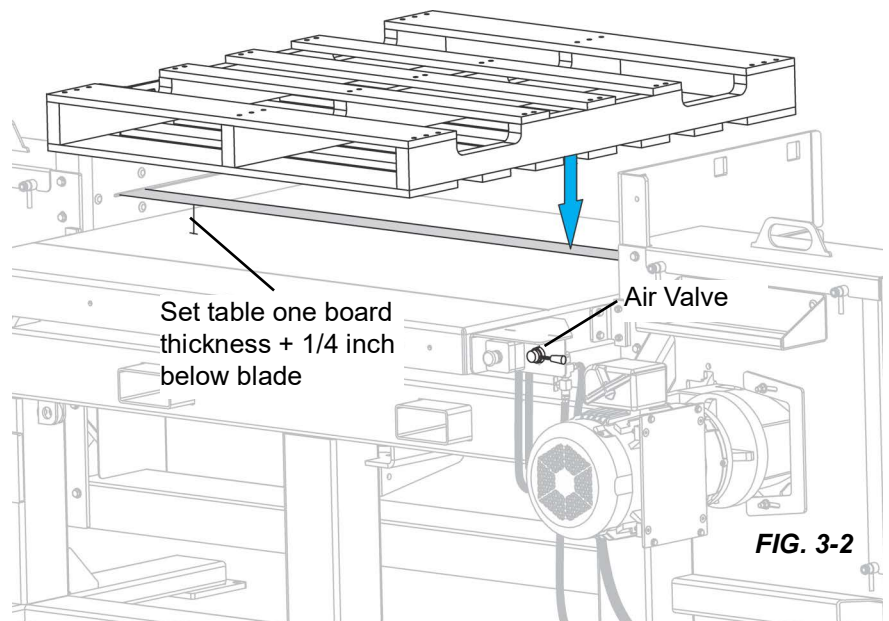

FIG. 3-2

14. Place half the pallet over the blade and lower the pallet so the blade is positioned between two deck boards. (See figure 3-2.)
15. Pull the pallet away from the blade.
16. Lift and rotate the pallet to remove the other half of the boards.
17. Turn the pallet over and repeat Step 14. through Step 16.
18. Remove the last board by pulling the stringers from left to right.

NOTE: Move the pallet from side-to-side as you pull to ease the cut.

Two-person operation

NOTICE BEFORE STARTING, ENSURE THE BLADE IS TENSIONED PROPERLY. FAILURE TO DO SO MAY RESULT IN DRIVE WHEEL TIRE DAMAGE.

1. Tighten the tension by ratcheting the device handle until the pivot arm is touching the stop bolt.

NOTE: If a new blade is required see Section 4.3 Changing the blade.

2. Momentarily (approximately 15 seconds) start the blade.
3. Turn off power.
4. Open the wheel covers to inspect the blade tracking.

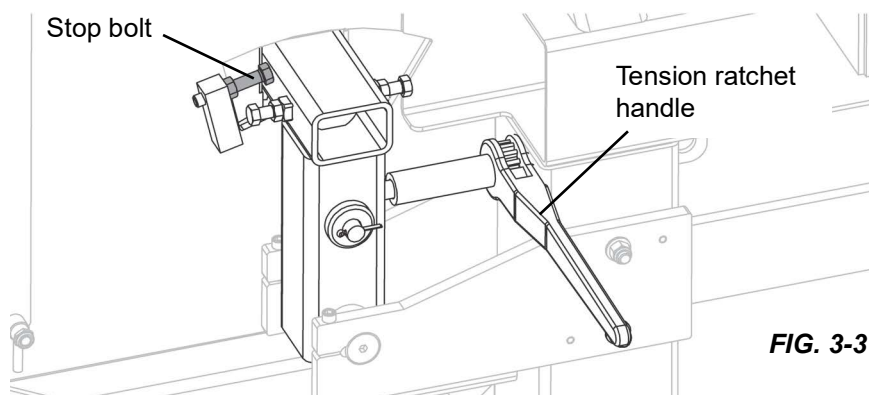

FIG. 3-3

NOTE: If the blade is not tracking in the center of the tire, refer to [Section 4.2 Tracking the blade](#).

5. When the blade is tracking properly, close the wheel covers and turn on the power.
6. Use the air valve to adjust the table approximately one board thickness plus 1/4 inch (6 mm) below the blade.

Air valve controls: Neutral is the 3 o'clock position. Raise the handle up to raise the table; lower handle to lower table. Always return the handle to the neutral position.

7. **Operator 1:** Place the pallet on the table with the deck side down and against the fence.
8. **Operator 1:** Start the blade.

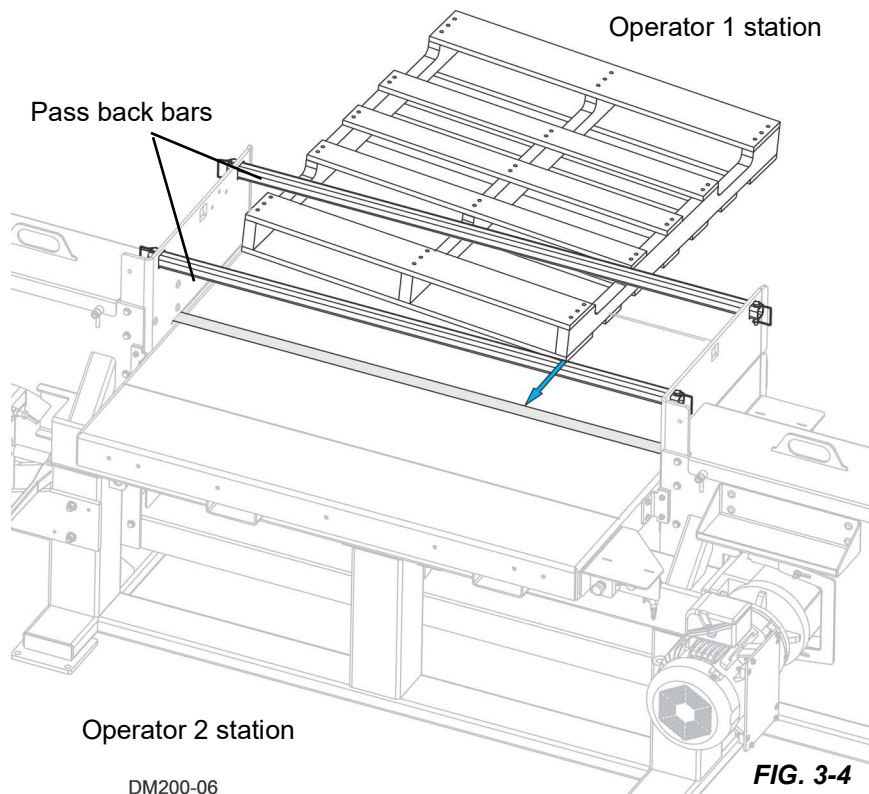

FIG. 3-4

NOTICE ONLY ONE PERSON SHOULD HAVE CONTACT WITH THE PALLET WHILE CUTTING.

9. **Operator 1:** With the pallet at a slight angle to the blade, push the pallet half way through the blade.(See Figure 3-4.)



DANGER! Keep hands 12” away from the blade. Failure to do so will result in death or serious injury.

NOTE: Move the pallet from side-to-side as you push or pull to ease the cut.

10. **Operator 2:** Pull the pallet completely through the blade.
11. **Operator 2:** TURN THE PALLET OVER AND PLACE IT ON THE PASS BACK BARS.
12. **Operator 1:** Place the pallet on the table and against the fence.
13. **Operator 1:** With the pallet at a slight angle to the blade, push the pallet half way through the blade.
14. **Operator 2:** Pull the pallet completely through the blade.
15. **Either operator.** Turn off blade.



DANGER! Remove power before clearing debris or any other maintenance activity.

16. **Operator 2:** Clear lumber and debris from the table to make it ready for the next pallet.
17. Repeat Step 7. through Step 16.

SECTION 4 MAINTENANCE



WARNING! Before performing service, lock out the electrical service as described in section 2.4. Failure to do so could result in death or serious injury.

Refer to Online Manuals for electrical schematics.

4.1 General maintenance after each use

1. Check for debris impeding any moving parts.
2. Clean debris off of the motor or engine and fuel tank.
3. Check engine oil per motor/engine manufacturer's manual specifications.
4. Check that the tire pressure are between 50-55 psi.
5. Check gearbox oil level per gearbox manufacturer's manual specifications.

NOTICE DO NOT OVERFILL THE GEARBOX. The gearbox is mounted in the B7 wall mounting position. In this mounting position the unit requires **6.1 PINTS** of oil.

Recommend lubricants are:

Mobile (Mobilgear 630)
Castrol (Alpha SP220)
Texaco (Meropa 220)

Citgo (EP Compound 220)
Shell (Omala 220)
Chevron (Gear Compound EP ISO2200)

4.2 Tracking the blade



WARNING! Before performing service, lock out the electrical service as described in section 2.4. Failure to do so could result in death or serious injury.

1. Open the wheel covers to observe the blade on the drive wheels.
2. Loosen the lock nuts on the tensioner.

3. Loosen the inner (**B**) while tightening the outer (**A**) bolt to move the blade **TOWARD THE BLADE GUIDE BEARING**.

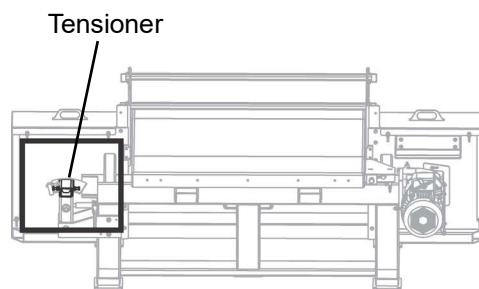

DM200-07

4. Loosen the outer (**A**) while tightening the inner (**B**) bolt to move the blade **AWAY FROM THE BLADE GUIDE BEARING**.

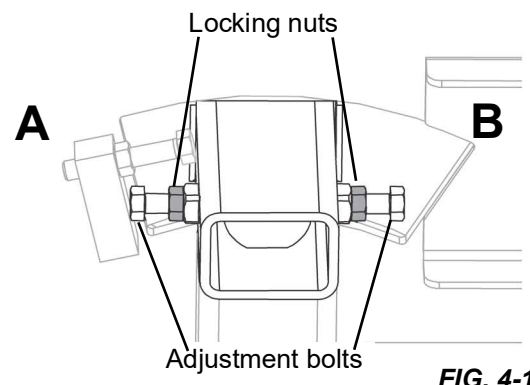

FIG. 4-1

NOTICE Do not move the adjustment bolts more than 1/4 turn per adjustment. This adjustment is sensitive.

5. Close the wheel covers.
6. Momentarily (approximately 15 seconds) start the blade.
7. Ensure power is off before performing the next steps.
8. Open the wheel covers to observe the blade on the drive wheels.
9. Repeat Step 3. through Step 8. as necessary for the blade to track properly.
10. Tighten the lock nuts when finished.

4.3 Changing the blade



WARNING! Before performing service, lock out the electrical service as described in section 2.4. Failure to do so could result in death or serious injury.

1. Open the wheel covers to observe the blade on the drive wheels.
2. Release the tension by ratcheting the device until the pivot arm is fully released.
3. Removed the used blade.
4. Install the new blade on the center of the drive wheel tires.

NOTICE Ensure the blade is positioned as shown below in Figure 4-3.

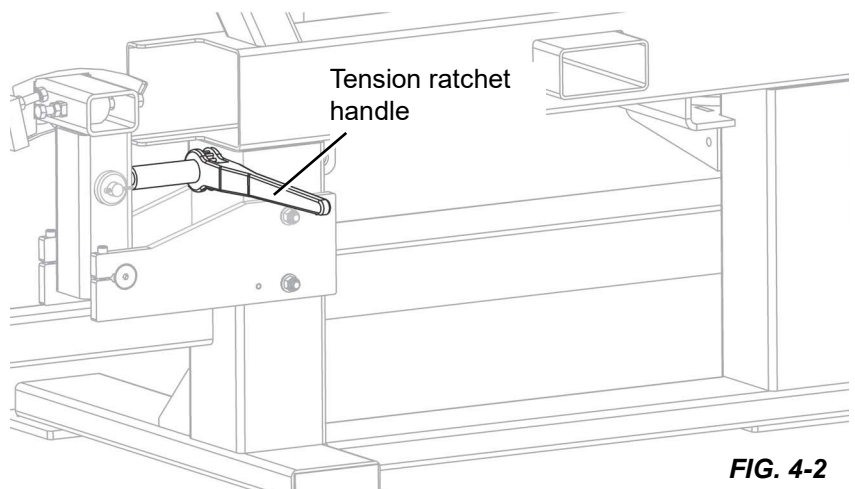
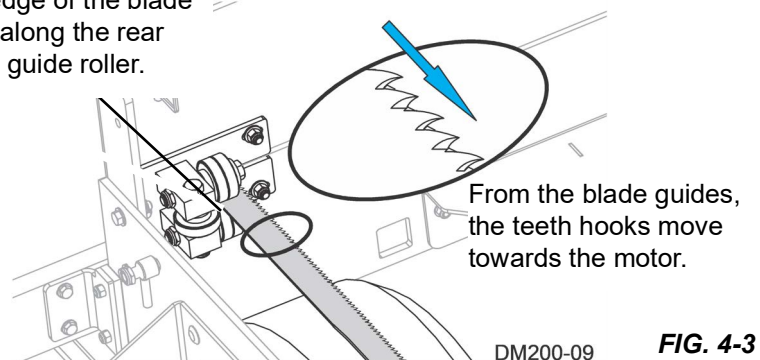

FIG. 4-2

5. Tighten the tension by ratcheting the device handle until the pivot arm is touching the stop bolt.

Flat edge of the blade rides along the rear blade guide roller.



DM200-09

FIG. 4-3

6. Close the wheel covers.
7. Momentarily (approximately 15 seconds) start the blade.
8. Ensure power is off before performing the next steps.
9. Open the wheel covers to observe the blade on the drive wheels.

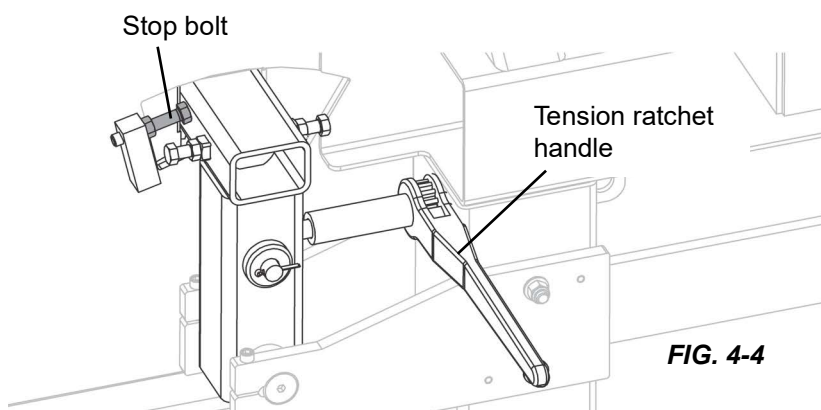

NOTE: If the blade is not tracking in the center of the tire, refer to [Section 4.2 Tracking the blade.](#)

10. When the blade is tracking properly, close the wheel covers and continue operations.

4.4 Remove the drive hub

Occasionally bearings will need to be changed on the gearbox.

1. Remove the blade drive wheel cover.
2. Loosen and remove the blade. Refer to [Section 4.3 Changing the blade.](#)
3. Remove the drive wheel by loosening and removing the six lug nuts.

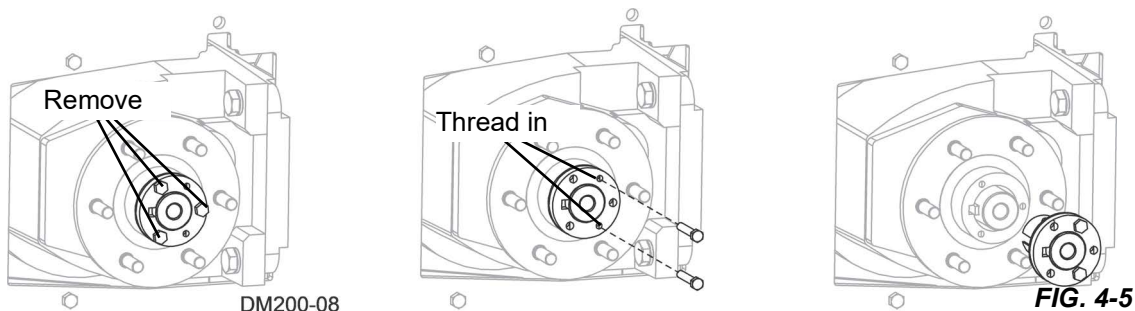

4. Remove the three bolts in the tapered bushing on the drive shaft.
5. Replace two of the bolts into the treaded holes.
6. Alternate tighten the two bolts until the bushing releases from the wheel flange.

The gearbox is now accessible for maintenance.

SECTION 5 REPLACEMENT PARTS

5.1 How To Use The Parts List

- Use the table of contents to locate the assembly that contains the part you need.
- Go to the appropriate section and locate the part in the illustration.
- Use the number pointing to the part to locate the correct part number and description in the table.
- Parts shown indented under another part are included with that part.

To Order Parts

- From the continental US, call **1-800-525-8100** to order parts. Have your customer number, vehicle identification number, and part numbers ready when you call.
- From other international locations, contact the Wood-Mizer distributor in your area for parts.

REF	PART #	DESCRIPTION	COMMENTS	QTY.
	012345	SAMPLE ASSEMBLY, COMPLETE (INCLUDES ALL INDENTED PARTS BELOW)		1
1	F02222-22	Sample Part		1
2	F03333-33	Sample Part		2
	098765	Sample Subassembly (Includes All Indented Parts Below)		1
3	S04444-44	Subassembly Sample Part		1
4	K55555	Subassembly Sample Part		1
	054321	Sample Sub-Subassembly (Includes All Indented Parts Below)		2
5	022222	Sub-Subassembly Sample Part		1
6	F10234-56	Sub-Subassembly Sample Part		1

The Sample Assembly, Complete, part number 02345 (top level assembly) includes two parts (F0222-22 and F0333-33) and the 098765 subassembly.

Subassembly 098765 contains two parts(S04444-44 and K55555) and two copies of sub-subassembly 054321.

Each sub-subassembly 054321 contains two parts (022222 and F10234-56).

5.2 Pallet Dismantler Assembly

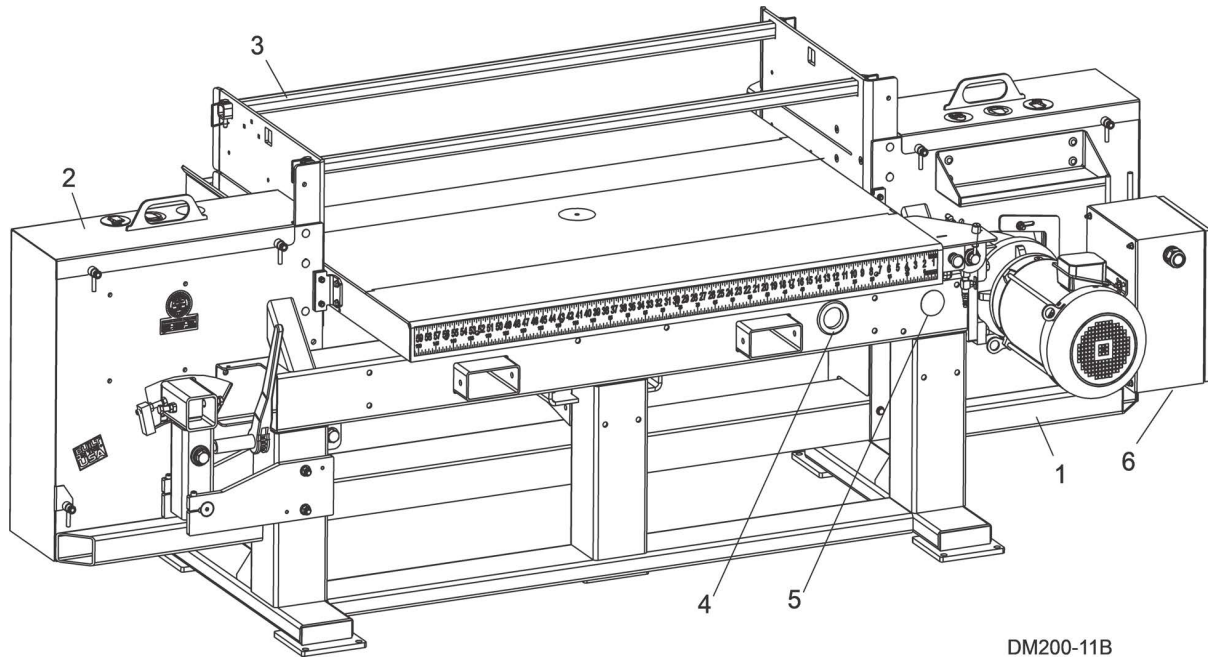

REF	PART #	DESCRIPTION	COMMENTS	QTY.
	PD200	Dismantler Assembly, Pallet		1
1		Pallet Dismantler Parts (Drive Side)	(See Section 5.3)	
2		Pallet Dismantler Parts (Idle Side)	(See Section 5.5)	
3		Pallet Dismantler Table Parts, Standard and Rear Drop	(See Section 5.6)	
4	085614	Grommet, Rubber 2 1/2 Dia		2
5	036462	Plug, 2 1/2 Dia Dome		1
6		Motor Control Assembly	See Section 5.10	

5.3 Pallet Dismantler Parts (Drive Side)

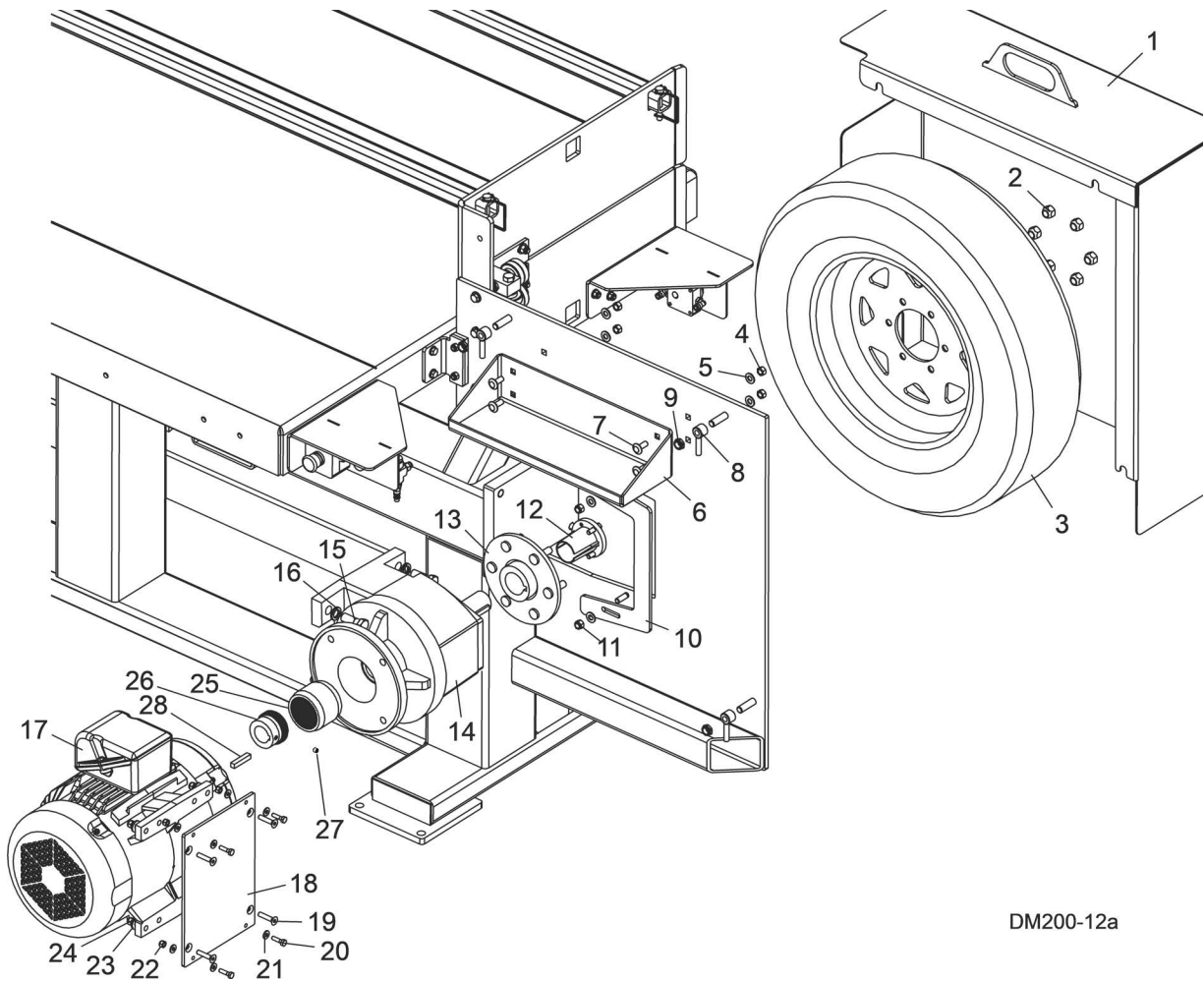

DM200-12a

REF	PART #	DESCRIPTION	COMMENTS	QTY.
1	079980	Cover Weldment, Dismantler, Drive		1
2	P04646	Nut, 1/2-20 Lug		6
3	133316	Tire/Wheel Assy, ST205/75D15		1
4	F05010-25	Nut, 3/8-16 Swaged Lock		4
5	F05011-3	Washer, 3/8 Flat SAE		6
6	079982	Tray, Dismantler Tool		1
7	F05007-165	Bolt, 3/8-16x1 Carriage, Zinc Grade 5		4
8	021145	Nut Weldment, Cover		3
9	F05010-127	Nut, 1/2-13 Half Nyloc		3
10	079981	Plate, Adapter		2
11	F05010-10	Nut, 3/8-16 Hex Nyloc		2
12	079945	Bushing, P2x1 5/8		1
13	079984	Hub Assembly, Dismantler Dr		1
14	079936	Reducer, 6:1 Inline	Parts to rebuild this reducer are available through Motion Industries. The model number is 772.1. The recommended gear oil is Mobile 630. Fill qty is 2.6 quarts. Oil is available in quart size through Grainger.	1
15	F05009-33	Bolt, 5/8-11x1 3/4 Hex Head		4

5 Replacement Parts
Pallet Dismantler Parts (Drive Side)

REF	PART #	DESCRIPTION	COMMENTS	QTY.
16	F05011-27	Washer, 5/8 Split Lock		4
17		Motor	See 5.4 Motors	
18	114116	Mount, PD200E Control		1
19	F05008-86	Bolt, 5/16-18x1 1/2 FH FT BO		4
20	F05005-101	Bolt, 1/4-20x1 Hex Head Grade 5		4
21	F05011-11	Washer, 1/4 SAE Flat		8
22	F05010-69	Nut, 1/4-20 Nylock		4
23	F05011-16	Washer, 5/16 Standard Flat		4
24	F05010-58	Nut, 5/16-18 Nylok Hex		4
	130150	Coupler Assy, M38x1 3/8 BoWex		1
25	130185	Sleeve, Bowex Coupler		1
	130184	Hub, Bowex Coupler, 1 3/8		1
26	130183_1	Part, New		1
27	F05004-234	Screw, M8-1.25x8mm SH Set BO		1
28	014693	Key, 3/8x3/8x1 7/8		4

5.4 Motors

Motor Part Number	Used with models	
079949 Motor, 10hp 1 PH Dismantler	PD200A10-SU	PALLET DISM,230V1PH10HP,STD TBL.,UL
	PD200A10-SUW	PALLET DISM,230V1PH10HP,STD TBL.,UL, 66"
	PD200A10-SUW72	PALLET DISM. 220V 1 PH. 10HP,STD.TBL. UL
	PD200A10-SUW84	PALLET DISM,220V1PH10HP,STD TBL.,UL, 84"
130065 Motor, 10HP 3525RPM, Lincoln	PD200B10-CU-HS	PALLET DISM, 230V 3PH10HP, CTR TBL, UL,
	PD200B10-RU-HS	PALLET DISM, 230V3PH10HP,REAR DRP, UL
	PD200C10-CUW72-HS	PALLET DISM, 460V3PH10HP,CTR TBL.,UL, HS
	PD200C10-RU-HS	PALLET DISM, 460V3PH10HP,REAR DRP, UL
	PD200B10-SU-HS	PALLET DISM,230V3PH10HP,STD TBL.,UL, HS
	PD200C10-CU-HS	PALLET DISM,460V3PH10HP,CTR TBL.,UL
	PD200C10-SU-HS	PALLET DISM,460V3PH10HP,STD TBL.,UL
	PD200C10-SUW-HS	PALLET DISM,460V3PH10HP,STD UL, 66", HS
130076 Motor, 10hp Dismantler 3ph	PD200B10-RUW72	PALLET DISM, 230V 3 PH 10 HP, REAR DRP
	PD200B10-CU	PALLET DISM, 230V 3PH10HP, CTR TBL, UL
	PD200B10-CUW72	PALLET DISM, 230V 3PH10HP, CTR TBL, UL
	PD200B10-RU	PALLET DISM, 230V3PH10HP,REAR DRP, UL
	PD200C10-RUW72	PALLET DISM, 460V 3 PH 10 HP, REAR DRP
	PD200C10-RU	PALLET DISM, 460V3PH10HP,REAR DRP, UL
	PD200B10-BU	PALLET DISM,230V3PH10HP,CTR TBL.,UL*OBS*
	PD200B10-SU	PALLET DISM,230V3PH10HP,STD TBL.,UL
	PD200B10-SUW	PALLET DISM,230V3PH10HP,STD TBL.,UL, 66"
	PD200B10-SUW72	PALLET DISM,230V3PH10HP,STD TBL.,UL, 72"
	PD200B10-SUW84	PALLET DISM,230V3PH10HP,STD TBL.,UL, 84"
	PD200B10-SUW96	PALLET DISM,230V3PH10HP,STD TBL.,UL, 96"
	PD200H10-SS	PALLET DISM,400V3PH50HZ,10HP,STD TBL
	PD200C10-CU	PALLET DISM,460V3PH10HP,CTR TBL.,UL
	PD200C10-SU	PALLET DISM,460V3PH10HP,STD TBL.,UL
	PD200C10-SUW	PALLET DISM,460V3PH10HP,STD TBL.,UL, 66"
	PD200C10-SUW72	PALLET DISM,460V3PH10HP,STD TBL.,UL, 72"
	PD200C10-SUW84	PALLET DISM,460V3PH10HP,STD TBL.,UL, 84"
110401 Motor, 10hp 575v, 1750rpm	PD200K10-CU	PALLET DISM, 575V 3PH10HP, CTR TBL, UL
	PD200K10-RU	PALLET DISM, 575V3PH10HP,REAR DRP, UL
	PD200K10-SU	PALLET DISM, 575V3PH10HP,STD TBL.,UL
	PD200K10-SUW72	PALLET DISM,575V3PH10HP,STD TBL.,UL, 72"

5.5 Pallet Dismantler Parts (Idle Side)

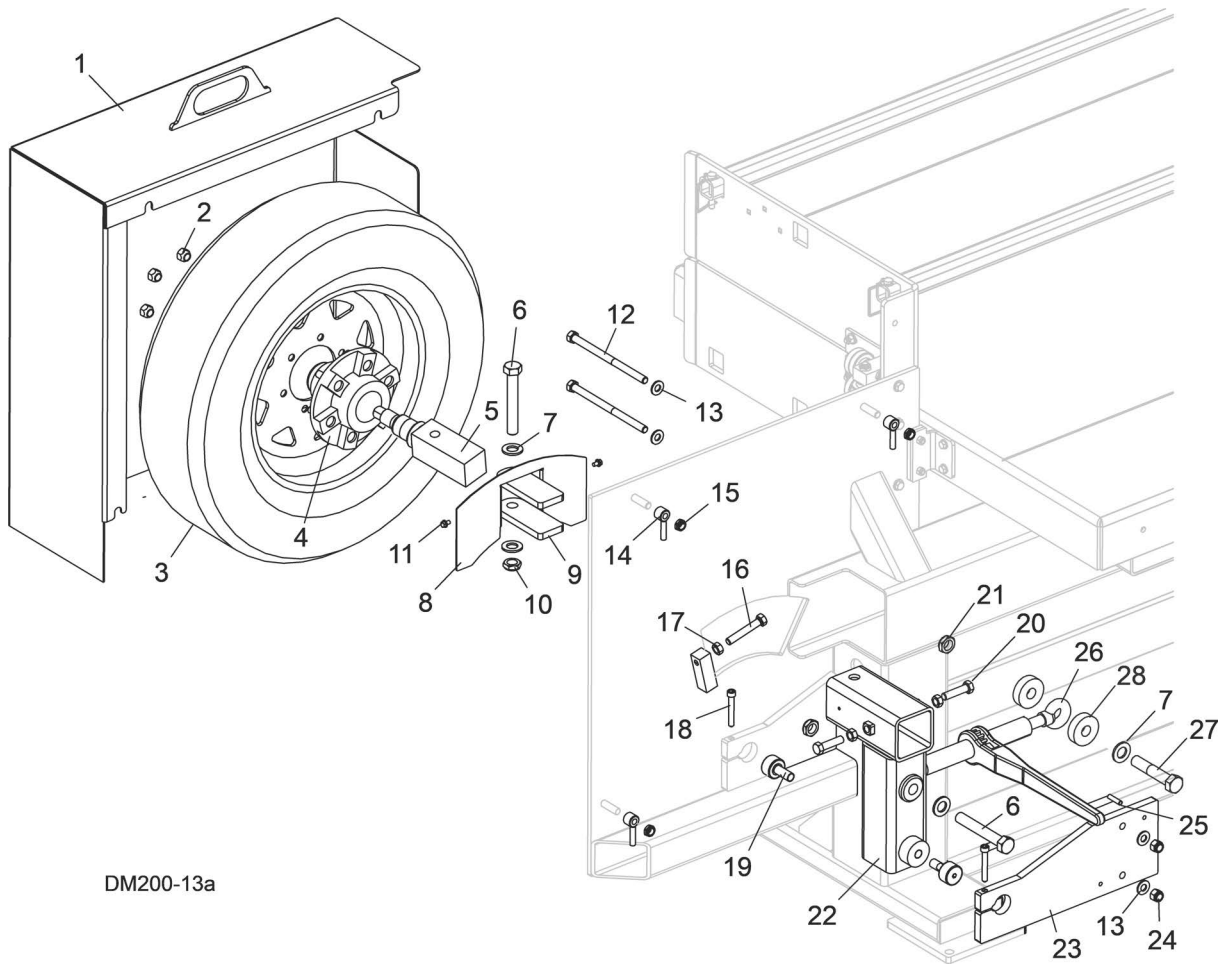

DM200-13a

REF	PART #	DESCRIPTION	COMMENTS	QTY.
1	079979	Cover Weldment, Dismantler Idle		1
2	P04646	Nut, 1/2-20 Lug		6
3	133316	Tire/Wheel Assy, ST205/75D15		1
	079921	Shaft Assembly, Dismantler		1
4	079941	Hub, 6 lug Dismantler		1
5	079992	Shaft, Dismantler Idle Machined		1
6	F05009-88	Bolt, 3/4-10x5 Hex Head Grade 5		2
7	F05011-62	Washer, 3/4 SAE Flat		4
8	079983	Guard, Dismantler Idler		1
9	079988	Spacer, Dismantler Idler Side		2
10	F05010-122	Nut, 3/4-10 Half Nyloc		1
11	F05005-78	Screw, 1/4-20x3/8 Hex Flanged Whiz Lock		2
12	F05008-69	Bolt, 1/2-13x8 Hex Head Grade 5		2
13	F05011-2	Washer, 1/2 SAE Flat		4
14	021145	Nut Weldment, Cover		3
15	F05010-127	Nut, 1/2-13 Half Nyloc		3
16	F05008-7	Bolt, 1/2-13x3 Full Thread Hex Head Tap		1
17	F05010-35	Nut, 1/2-13 Hex		3
18	F05007-24	Screw, 3/8-16x2 1/2 SHC		2

REF	PART #	DESCRIPTION	COMMENTS	QTY.
19	012797	Bearing, Cam Follower 1 1/2		2
20	F05008-116	Bolt, 1/2-13x2 Full Thread Grade 5		2
21	F05010-122	Nut, 3/4-10 Half Nyloc		2
22	079960	Tensioner Weldment, Dismantler		1
23	079963	Plate, Tensioner Mount		1
24	F05010-8	Nut, 1/2-13 Nyl Hex Lock		2
25	F05012-127	Pin, 5/16x1 1/4 Roll		2
26	079975	Tensioner Ratchet, Dismantler		1
27	F05013-3	Bolt, 3/4-10x2 Hex Head Grade 5		1
28	130258	Spacer, 3/4x2 3/16x5/8		2

5.6 Pallet Dismantler Table Parts

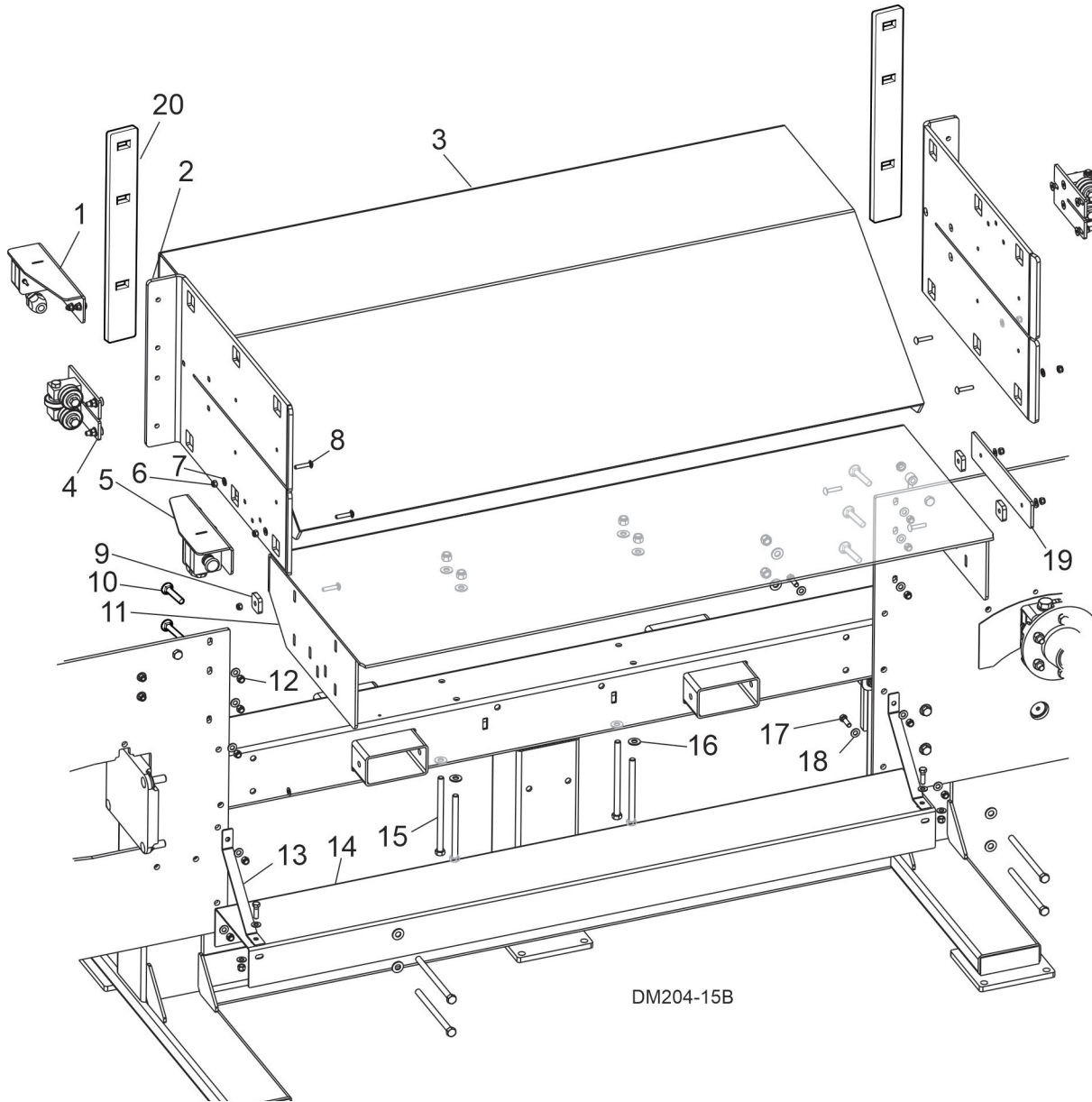

REF	PART #	DESCRIPTION	COMMENTS	QTY.
1	079685	Control Assy, Dismantler Rear, CD	(See Section 5.7)	1
2	079953	Plate, Dismantler Fence		2
3	079652	Table Wldmnt, Center Drop, Front		1
	079652-72	Table Wldmnt, Center Drop, Front, 72		1
4	079957	Blade Guide Assy, Dismantler	(See Section 5.9)	2
5	079681	Control Assy, Dismantler Front, CD	(See Section 5.7)	1
6	F05010-58	Nut, 5/16-18 Nylok Hex		10
7	F05011-17	Washer, 5/16 SAE Flat		10
8	F05006-153	Bolt, 5/16-18x1-1/2 Carriage Gr5		10
9	079659	Spacer, Dismantler Table		4
10	F05007-235	Bolt, 3/8-16x1 3/4 Carriage Gr5		6
11	079654	Table Wldmnt, Center Drop, Rear		1

REF	PART #	DESCRIPTION	COMMENTS	QTY.
	079654-72	Table Wldmnt, Center Drop, Rear 72		1
12	F05010-10	Nut, 3/8-16 Hex Nyloc		20
13	079964	Gusset, 7 3/4 x 7 3/4		2
14	079998	Frame Weldment, 60" Dismantler, CU		1
	079998-72	Frame Weldment, 72" Dismantler, CU		1
15	F05008-87	Bolt, 1/2-13x7 1/2 HH FT		8
16	F05011-2	Washer, 1/2 SAE Flat		20
17	F05007-123	Bolt, 3/8-16x1 1/4 Full Thread Hex Head Grade 5		6
18	F05011-3	Washer, 3/8 Flat SAE		30
19	079660	Plate, Table Mount		1
20	133404	Strip, PD200 Guide		2
	130824	Blades, Pallet Dismantler 268" Pack (3) (For Standard (60") units)		1
	130826	Blades, Pallet Dismantler 292" Pack (3) (For 72" units)		1

5.7 Table Control Assembly

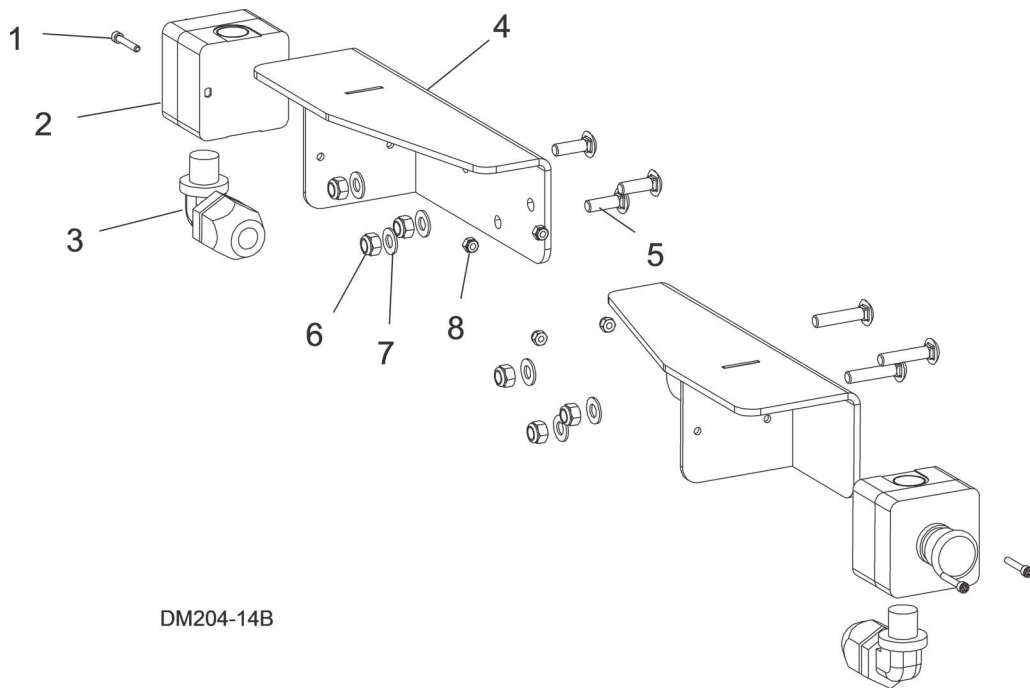

REF	PART #	DESCRIPTION	COMMENTS	QTY.
	079685	CONTROL ASSY, DISMANTLER REAR, CD		1
	079681	CONTROL ASSY, DISMANTLER FRONT, CD		1
1	F05004-295	Screw, 8-32x1 SHC Brass		2
2	052999	E-Stop Box, 40mm Oper-10A NC		1
3	E22722	Connector, 1/2In 90 Deg Liquid Tight		1
4	079686	Brkt Weldment, Rear Control, CD	Front and rear are mirror images of each other.	1
	079682	Brkt Weldment, Front Control, CD		2
5	f05006-90	Bolt, 5/16-18x1 Carriage Gr5		3
6	F05010-58	Nut, 5/16-18 Nylok Hex		3
7	F05011-17	Washer, 5/16 SAE Flat		3
8	F05010-169	Nut, #8-32 Hex Nylock		2

5.8 Motor Control Assembly

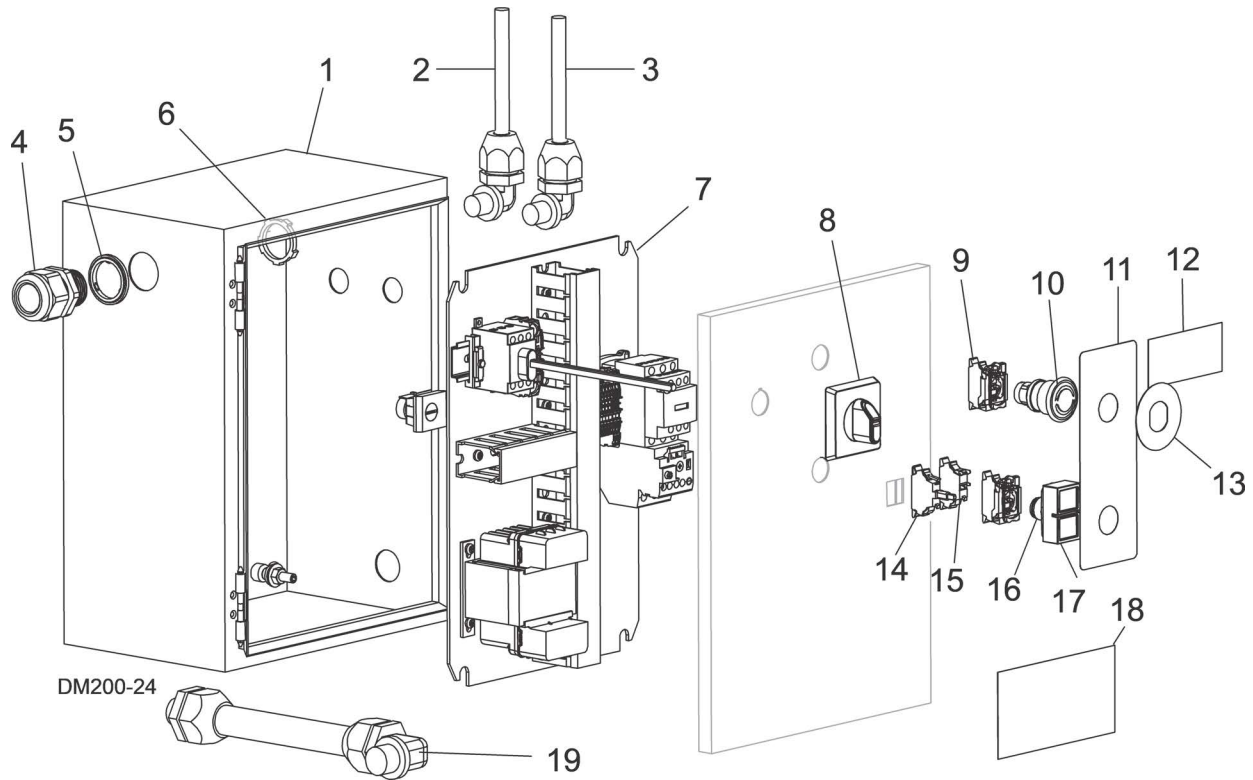

REF	PART #	DESCRIPTION	COMMENTS	QTY.
	114100	CONTROL ASSY, PD200A10 240VAC 1PH		1
	114104	CONTROL ASSY, PD200B/C10 240/480VAC 3PH		1
	114113	CONTROL ASSY, PD200K10 575VAC 3PH		1
1	114115	Enclosure, Elec. Control PD200E		1
2	114111	Harness Assy, Rear E-Stop PD200E		1
3	114110	Harness Assy, Front E-Stop PD200E		1
4	069861	Connector, 1" NPT 0.59-1.00		1
5	053734	Ring, 1" Sealing		1
6	053735	Nut, 1" NPT Connector Lock Sealing		1
7	114102	Insert, Panel Assy PD200A10 240VAC 1PH		1
	114105	Insert, Panel Assy. PD200B/C10 240/480V 3PH		1
	114114	Insert, Panel Assy. PD200K10 575VAC 3PH		1
8	050883-1	Handle, Disconnect RED/YEL 6mm Shaft		1
9	068950	Collar, Mount 1NC ZB5		2
10	068940	Push-Button, Mshrm Mntnd Red TrnRI ZB5		1
11	114112	Decal, PD200E Control		1
12	114100-NPLBL	Label, PD200A10 Elec Nameplate		1
	114104-NPLBL	Label, PD200B/C10 Elec. Name		1
	114104-NPLBL	Label, PD200K10 Elec. Name		1
13	050992	Legend, E-Stop, Round Yellow		1
14	068910	Light Module, Green ZB5		1
15	068920	Contact Block, NO ZB5		1

5 Replacement Parts
Motor Control Assembly

REF	PART #	DESCRIPTION	COMMENTS	QTY.
16	068909	Push-Button, Grn/Red Flush Illuminated		1
17	052501	Boot, Clear Sealing ZB Sw		1
18	S20061	Decal, Electrical Hazard Danger		1
19	114108	Harness Assy, PD200 240VAC 1PH		1
	114109	Harness Assy, PD200 240/480 VAC 3PH		1
	114117	Harness Assy, PD200 575VAC 3PH		1

5.9 Blade Guide Assembly

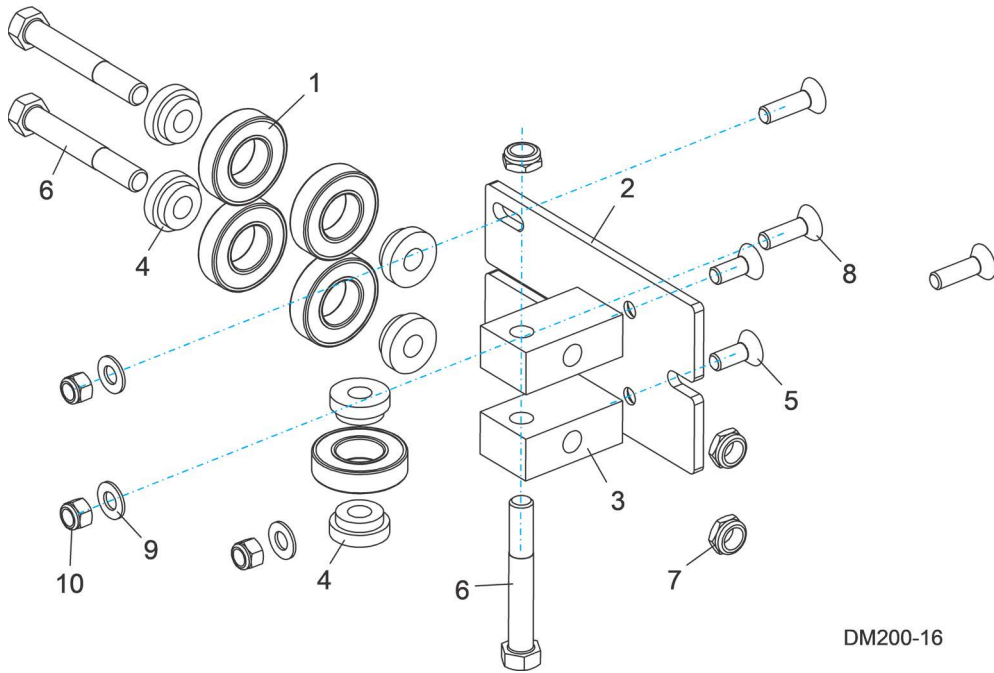

DM200-16

REF	PART #	DESCRIPTION	COMMENTS	QTY.
	079957	Blade Guide Assembly, Dismantler		2
1	042360	Bearing, R16 Sealed		5
2	079954	Mount, B/G Bearing		1
3	079955	Block, Dismantler Blade Guide		2
4	079956	Spacer, Dismantler Blade Guide		6
5	F05007-64	Screw, 3/8-16x1 Zinc & Bake FSHC		2
6	F05008-61	Bolt, 1/2-13x3 1/2 HH Gr5		3
7	F05010-127	Nut, 1/2-13 Half Nyloc		3
8	F05007-247	Screw, 3/8-16 x 1-1/2 FHS SS		3
9	F05011-3	Washer, 3/8 Flat SAE		3
10	F05010-10	Nut, 3/8-16 Hex Nyloc		3

5.10 Decals

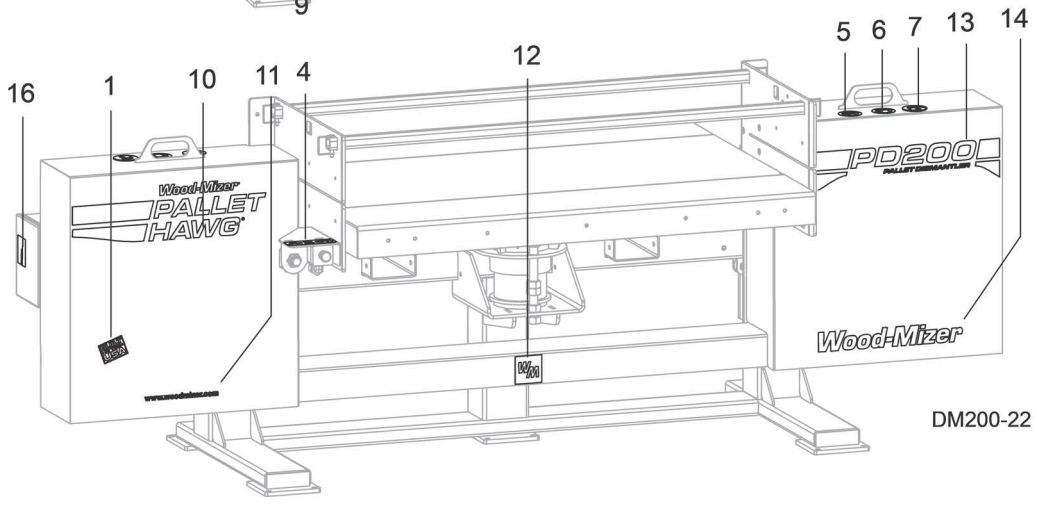
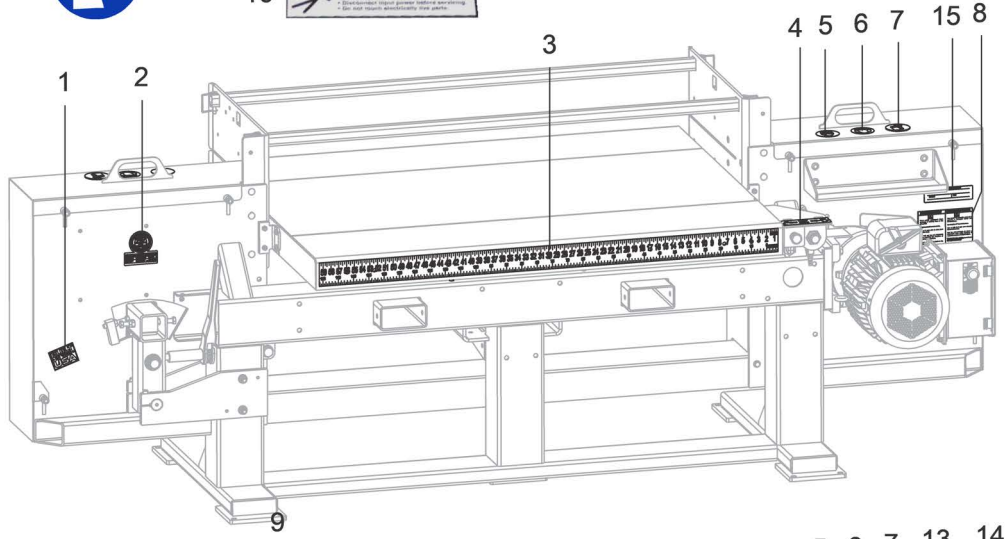
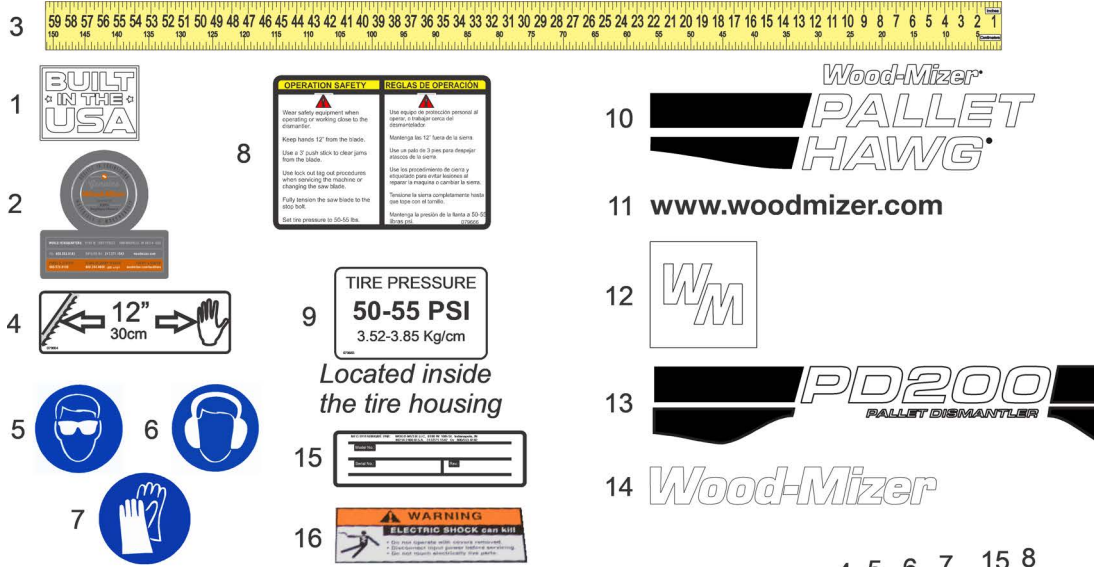

REF	PART #	DESCRIPTION	COMMENTS	QTY.
	079680	Decal Kit, Dismantler		2
1	074008	Decal, Built In The USA		2

REF	PART #	DESCRIPTION	COMMENTS	QTY.
2	079278	Decal, Wood-Mizer Quality & Information		1
3	079667	Decal, Pallet Scale		1
4	079664	Decal, Keep 12" Away		2
5	S12004G	Decal, Eye Warning		2
6	S12005G	Decal, Ear Warning		2
7	512107	Decal, Hand Protection		2
8	079666	Decal, Pallet Hawg Operation		1
9	079665	Decal, Pallet Hawg Tire Pressure		2
10	079661	Decal, Pallet Hawg		1
11	003235	Decal, Wood-Mizer Website		1
12	079663	Decal, WM Badge		2
13	079662	Decal, PD200		1
14	065025	Decal, Wood-Mizer Logo Wht LT40,50		1
15	015820	Decal, ID Serial No.		1
16	110781	Decal, Danger High Voltage	The original safety decal on the control box came from the vendor. If needing a replacement, order the 110781.	1

5.11 Trailer Front (Optional)

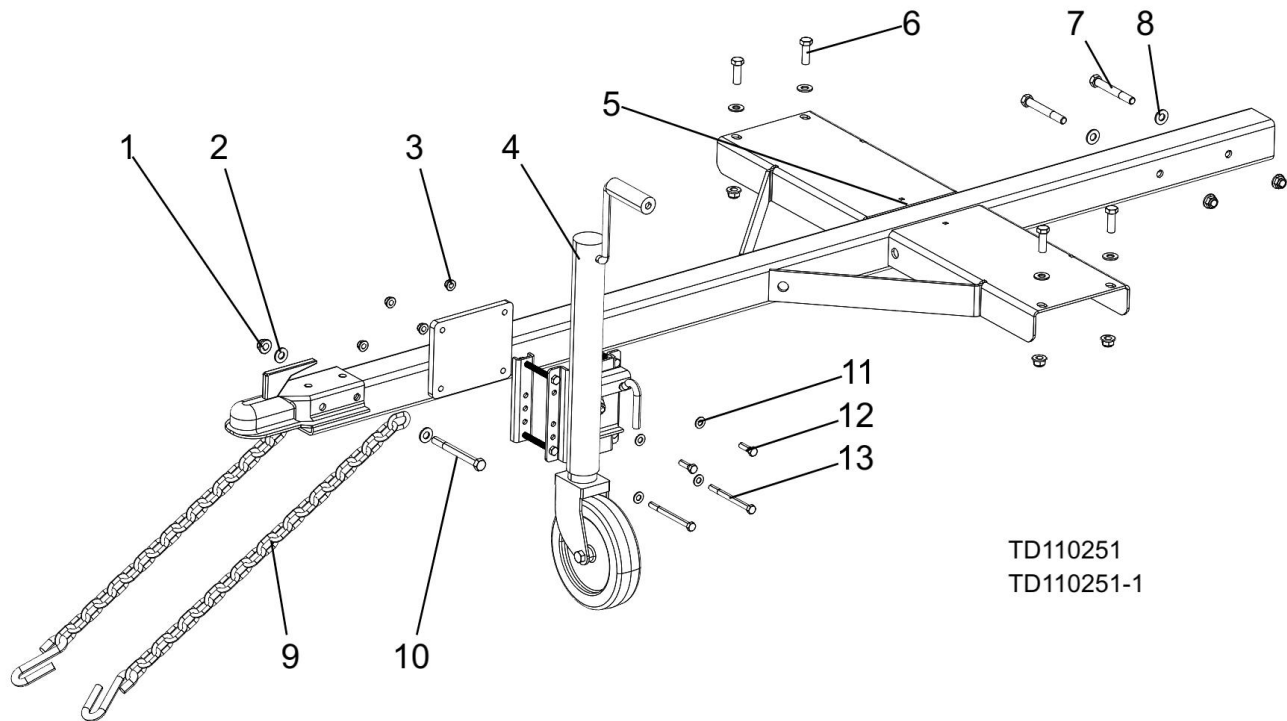

TD110251
TD110251-1

REF	PART #	DESCRIPTION	COMMENTS	QTY.
1	F05010-223	Nut, 1/2-13 Flanged Hex Nylock		7
2	F05011-101	Washer, 1/2 SAE Flat Gr5-8		2
3	F05010-222	Nut, 3/8-16 Flanged Hex Nylock		4
4	074997	Jack, Trailer Wheel 1500 lbs		1
5	110250	Hitch Frame Wldmnt, PD200		1
6	F05008-33	Bolt, 1/2-13x1 1/2 HH Gr5		4
7	F05008-78	1/2-13 x 4 HHB GR5 ZINC		2
8	F05011-2	Washer, 1/2 SAE Flat		6
9	107163	Chain, 30 Inch Safety		2
10	F05008-66	BOLT, 1/2-13 X 5 GR5 ZINC HEX HEAD		1
11	F05011-3	Washer, 3/8 Flat SAE		6
12	F05007-123	Bolt, 3/8-16x 1 1/4 HH Gr5		2
13	F05007-35	Bolt, 3/8-16x4 1/2 Hex Head Gr5 Zinc		2

5.12 Trailer Rear (Optional)

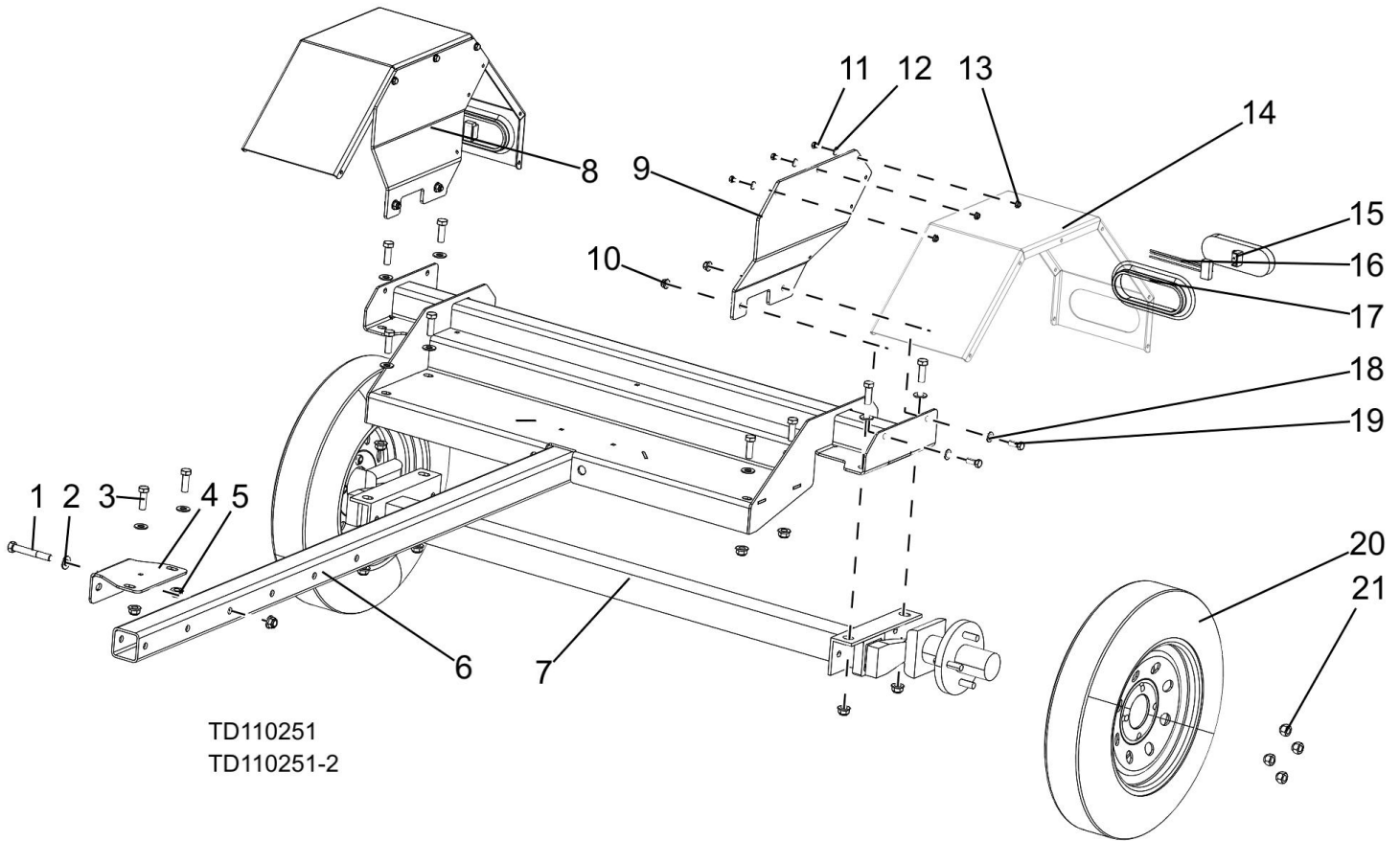

TD110251
TD110251-2

REF	PART #	DESCRIPTION	COMMENTS	QTY.
1	F05008-61	Bolt, 1/2-13x3 1/2 Hex Head GR5 Zinc		1
2	F05011-2	Washer, 1/2 SAE Flat		11
3	F05008-33	Bolt, 1/2-13x1 1/2 HH Gr5		10
4	110246	Mount Angle, PD200 Mid		1
5	F05010-223	Nut, 1/2-13 Flanged Hex Nylock		11
6	110249	Axle Frame Wldmnt, PD200		1
7	079363	Axle, 2200 LBS		1
8	110244	Fender Mount, PD200 RH		1
9	110245	Fender Mount, PD200 LH		1
10	F05010-222	Nut, 3/8-16 Flanged Hex Nylock		4
11	F05005-123	Bolt, 1/4-20x3/4 HH Gr5		6
12	F05011-11	Washer, 1/4 SAE Flat		6
13	F05010-220	Nut, 1/4-20 Flanged Hex Nylock		6
14	TS-1224	Plate, Fender FS300		2
15	074710	Light, 7 Diode LED Tail		2
16	074711	Plug, 3 Wire Tail Light		2
17	006688	Grommet, 6 1/2 Light Mounting		2
18	F05011-3	Washer, 3/8 Flat SAE		4
19	F05007-87	Bolt, 3/8-16x1 Gr5 HH		4
20	133318	Tire Wheel Assy, 480-12		2
21	P04646	Nut, 1/2-20 Lug		8