

HR300 Series
Replacement Parts

HR300 Series

rev. A2.02

Safety is our #1 concern!

Form #1696



WARNING! Read and understand this manual before using this machine.

California
Proposition 65 Warning



WARNING: Breathing gas/diesel engine exhaust exposes you to chemicals known to the State of California to cause cancer and birth defects or other reproductive harm.

- Always start and operate the engine in a well-ventilated area.
- If in an enclosed area, vent the exhaust to the outside.
- Do not modify or tamper with the exhaust system.
- Do not idle the engine except as necessary.

For more information go to **www.P65warnings.ca.gov**.



WARNING: Drilling, sawing, sanding or machining wood products can expose you to wood dust, a substance known to the State of California to cause cancer. Avoid inhaling wood dust or use a dust mask or other safeguards for personal protection.

For more information go to **www.P65Warnings.ca.gov/wood**.

Active Patents assigned to Wood-Mizer, LLC

Wood-Mizer, LLC has received patents that protect our inventions which are a result of a dedication to research, innovation, development, and design. Learn more at: woodmizer.com/patents

©2022 Wood-Mizer LLC

Printed in the United States of America, all rights reserved. No part of this manual may be reproduced in any form by any photographic, electronic, mechanical or other means or used in any information storage and retrieval system without written permission from

Wood-Mizer, LLC
8180 West 10th Street
Indianapolis, Indiana 46214

Table of Contents

Section-Page

SECTION 1	REPLACEMENT PARTS	1-1
1.1	How To Use The Parts List.....	1-1
1.2	Sample Assembly.....	1-1
SECTION 2	BLADE GUIDES	2-1
2.1	Blade Guide Assembly, Idle Side	2-1
2.2	Blade Guide Assembly, Drive Side	2-5
SECTION 3	BLADE WHEELS & DRIVE	3-1
3.1	Blade Drive Assembly	3-1
3.2	Drive Belt Covers and Brake Solenoid.....	3-3
3.3	Blade Motor Assembly (20HP).....	3-5
3.4	Blade Motor Assembly (25HP).....	3-6
3.5	Blade Motor Assembly (10HP).....	3-7
3.6	Idle Blade Wheel Assembly.....	3-8
SECTION 4	SAW HEAD	4-1
4.1	Blade Tensioner Assembly	4-1
4.2	Middle Throat Screw	4-3
4.3	Water Lube Assembly.....	4-4
4.4	Covers & Sawdust Chute	4-5
4.5	Saw Head Decals	4-7
SECTION 5	UP/DOWN	5-1
5.1	Mast Assembly.....	5-1
5.2	Up/Down System Assembly	5-3
SECTION 6	FEED	6-1
6.1	Feed Track Assembly.....	6-1
6.2	Feed Motor Assembly	6-3
6.3	Stationary Feed Rollers.....	6-5
6.4	Pressure Roller Assembly	6-6
6.5	Pressure Roller Chain Assembly.....	6-9
SECTION 7	FRAME	7-1
7.1	Saw Head Tilt Assembly.....	7-1
7.2	Control Box & Harnesses	7-3
SECTION 8	OPTIONS	8-1
8.1	End Table (Optional)	8-1
8.2	Feed Tables (Optional).....	8-2
8.3	Side Table (Optional).....	8-3
8.4	Lube-Mizer Pump Assembly (Optional).....	8-4

SECTION 1 REPLACEMENT PARTS

1.1 How To Use The Parts List

- Use the table of contents to locate the assembly that contains the part you need.
- Go to the appropriate section and locate the part in the illustration.
- Use the number pointing to the part to locate the correct part number and description in the table.
- Parts shown indented under another part are included with that part.

To Order Parts

- From the continental US, call **1-800-525-8100** to order parts. Have your customer number, vehicle identification number, and part numbers ready when you call.
- From other international locations, contact the Wood-Mizer distributor in your area for parts.

1.2 Sample Assembly



REF	PART #	DESCRIPTION	COMMENTS	QTY.
	012345	SAMPLE ASSEMBLY, COMPLETE	INCLUDES ITEMS 1-6	1
1	F02222-22	Sample Part		1
2	F03333-33	Sample Part		2
	098765	Sample Subassembly	Includes items 3-6	1
3	S04444-44	Subassembly Sample Part		1
4	K55555	Subassembly Sample Part		1
	054321	Sample Sub-Subassembly	Includes items 5-6	2
5	022222	Sub-Subassembly Sample Part		1
6	F10234-56	Sub-Subassembly Sample Part		1

The Sample Assembly, Complete, part number 02345 (top level assembly) includes two parts (F0222-22 and F0333-33) and the 098765 subassembly.

Subassembly 098765 contains two parts(S04444-44 and K55555) and two copies of sub-subassembly 054321.

Each sub-subassembly 054321 contains two parts (022222 and F10234-56).

1.3 Torque Values

Grade		Units	SAE 5	SAE 8
Grade Mark				
Bolt Dia.	Threads Per In.	Units	SAE 5	SAE 8
6	32	in-lbs (Nm)	20 (2.3)	-
8	32	in-lbs (Nm)	24 (2.7)	30 (3.4)
10	24	in-lbs (Nm)	35 (4.0)	45 (5.1)
10	32	in-lbs (Nm)	40 (4.5)	50 (5.7)
12	24	in-lbs (Nm)	50 (5.7)	65 (7.3)
1/4	20	in-lbs (Nm)	95 (10.7)	125 (14.1)
1/4	28	in-lbs (Nm)	95 (10.7)	150 (17.0)
5/16	18	ft-lbs (Nm)	17 (22.6)	23 (31.2)
5/16	24	ft-lbs (Nm)	20 (27.1)	25 (33.8)
3/8	16	ft-lbs (Nm)	30 (40.7)	40 (54.2)
3/8	24	ft-lbs (Nm)	35 (47.5)	45 (61.0)
7/16	14	ft-lbs (Nm)	50 (67.8)	65 (88.1)
7/16	20	ft-lbs (Nm)	55 (74.6)	70 (94.9)
1/2	13	ft-lbs (Nm)	75 (101.7)	100 (135.6)
1/2	20	ft-lbs (Nm)	85 (115.3)	110 (149.2)
9/16	12	ft-lbs (Nm)	105 (142.4)	135 (183.1)
9/16	18	ft-lbs (Nm)	115 (155.9)	150 (203.4)
5/8	11	ft-lbs (Nm)	150 (203.4)	195 (264.4)
5/8	18	ft-lbs (Nm)	160 (217.0)	210 (284.8)
3/4	10	ft-lbs (Nm)	170 (230.5)	220 (298.3)
3/4	16	ft-lbs (Nm)	175 (237.3)	225 (305.1)
7/8	9	ft-lbs (Nm)	302 (409.5)	473 (640.9)
7/8	14	ft-lbs (Nm)	300 (406.8)	400 (542.4)
1	8	ft-lbs (Nm)	466 (631.8)	714 (967.4)

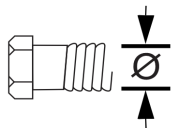

Metric Bolt Head Identification



Metric Grade 8.8



Metric Grade 10.9

Diameter & Thread Pitch	COARSE THREAD				FINE THREAD				Wrench Size	
	Metric 8.8		Metric 10.9		Metric 8.8		Metric 10.9			
	N-m	lbs-ft	N-m	lbs-ft	N-m	lbs-ft	N-m	lbs-ft		
6 x 1.0	8	6	11	8					10 mm	
8 x 1.25	20	15	27	20	8 x 1.0	21	16	29	22	13 mm
10 x 1.5	39	29	54	40	10 x 1.25	41	30	57	42	16 mm
12 x 1.75	68	50	94	70	12 x 1.25	75	55	103	76	18 mm
14 x 2.0	109	80	151	111	14 x 1.5	118	87	163	120	21 mm
16 x 2.0	169	125	234	173	16 x 1.5	181	133	250	184	24 mm
18 x 2.5	234	172	323	239	18 x 1.5	263	194	363	268	27 mm
20 x 2.5	330	244	457	337	20 x 1.5	367	270	507	374	30 mm
22 x 2.5	451	332	623	460	22 x 1.5	495	365	684	505	34 mm
24 x 3.0	571	421	790	583	24 x 2.0	623	459	861	635	36 mm
30 x 3.0	1175	867	1626	1199	30 x 2.0	1258	928	1740	1283	46 mm

SECTION 2 BLADE GUIDES

2.1 Blade Guide Assembly, Idle Side

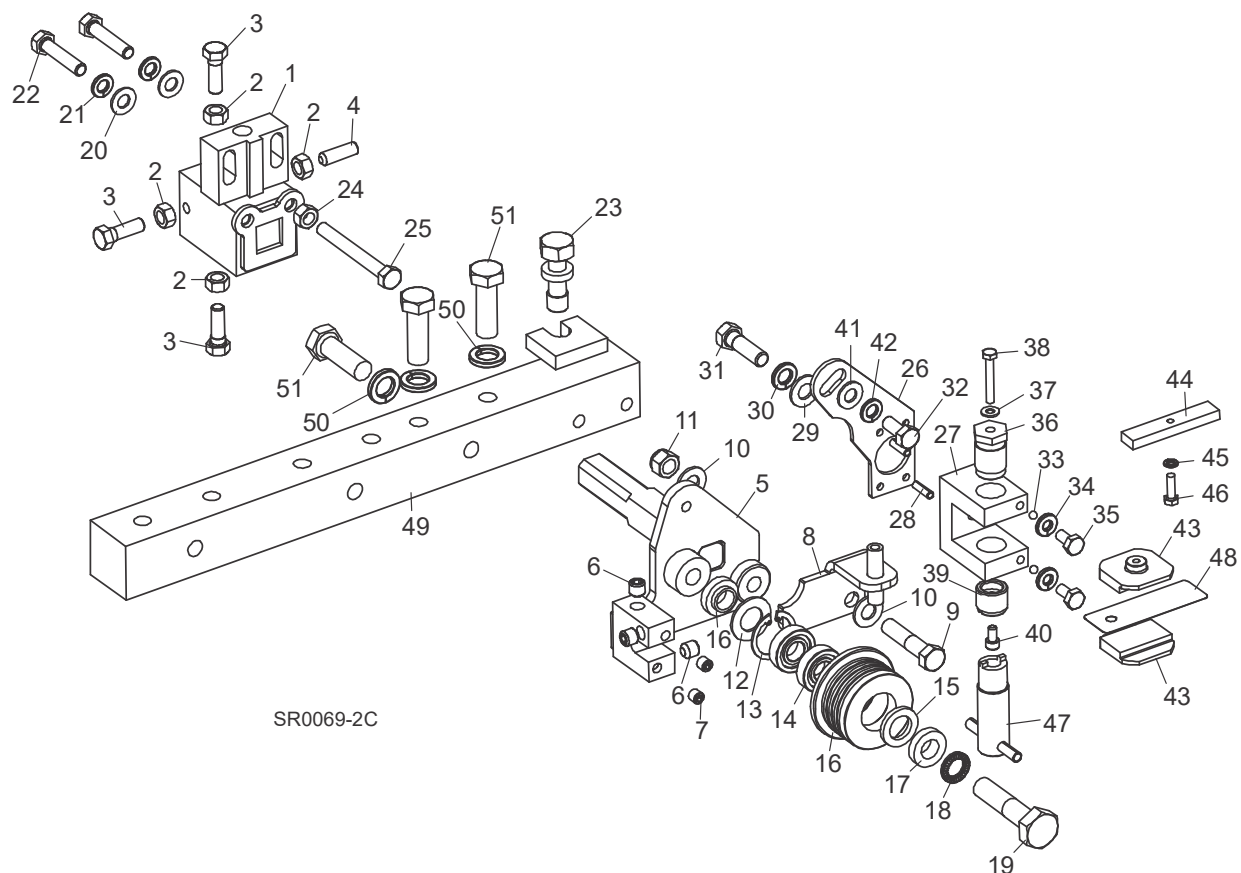

SR0069-2C

REF	PART #	DESCRIPTION	COMMENTS	QTY.
	006338	GUIDE ASSEMBLY, IDLE SIDE BLADE ROLLER		1
	065677	Block Assembly, Blade Guide Mount		1
1	003911	Block Weldment, Blade Guide Mount	Available in assemblies only.	1
2	F05010-17	Nut, 5/16-18 Hex		4
3	F05006-88	Bolt, 5/16-18 x 1" Hex Head Stainless Steel		3
4	F05006-122	Screw, 5/16-18 x 1" Socket Head Flat Point Stainless Steel Set		1
5	003924	Shaft Weldment, Idle Side Guide		1
6	P30127	Fitting, 1/8" NPT Socket Pipe Plug		3
7	007734	Fitting, 1/16" NPT Socket Pipe Plug		2
8	006322	Bracket Weldment, Water Lube		1
9	F05007-119	Bolt, 3/8-16UNF-2A x 1 3/4" Grade 5		1
10	F05011-3	Washer, 3/8" SAE Flat		2
11	F05010-10	Nut, 3/8-16 Hex Nylon Lock		1

REF	PART #	DESCRIPTION	COMMENTS	QTY.
	A04925	Roller Assembly, Blade Guide (standard for use with 1 1/4" & 1 1/2" blades)	The resaw is equipped standard with blade guide rollers that can be used with the standard 1 1/4" blade or 1 1/2" blades. Optional extended blade guide rollers are available for use with 1 1/2" blades. The extended rollers may provide more stability during difficult sawing, but will reduce the total amount of times the blade can be reused after sharpening. Use kit 006382 to convert the rollers and guide blocks for both blade guides for 1 1/2" blades.	1
	014299	Roller Assembly, Extended Blade Guide (optional for use with 1 1/2" blades)		1
	K07079	Bearing Kit, Blade Guide Rebuild		1
12	P04252	Washer, 5/8" White Felt		1
13	F04254-1	Ring, 1 1/8" Interior Retaining		1
14	015975	Bearing, R8-2RS Blade Guide	Available in assemblies only.	2
15	P06455	Washer, 5/8" Gray Felt		1
	F05005-105	Screw, 1/4-28 x 1/4" Socket Head Cup Point Set Black Oxide		1
	057407-1507	Instruction Sheet, Blade Guide Rebuild		1
16	S04250	Roller, Flanged Blade Guide (1 1/4" & 1 1/2" blade)	Available in assemblies only.	1
	014298	Roller, Flanged Blade Guide (1 1/2" blade)	Available in assemblies only.	1
	A04925-364	Instruction Sheet, Blade Guide Roller Replacement		1
17	S04253	Spacer, Blade Guide		2
18	F05011-125	Washer, 1/2" Nord-Lock		1
19	F05008-10	Bolt, 1/2-13 x 2 1/4" Hex Head Grade 5		1
20	F05011-17	Washer, 5/16" SAE Flat		2
21	F05011-13	Washer, 5/16" Split Lock		2
22	F05006-76	Bolt, 5/16-18 x 1 1/2" Hex Head		2
23	035656	Bolt, Blade Guide Vertical Adjustment		1
24	F05010-17	Nut, 5/16-18 Hex		1
25	F05006-136	Bolt, 5/16-18 x 2 3/4" Hex Head Full Thread		1
	006340	GUIDE KIT, HIGH-PERFORMANCE BLADE GUIDE (OPTIONAL)	High-Performance Blade Guide Kit requires LMS blade lube system. If resaw already equipped with LMS, use kit 006340 to upgrade both drive and idle side blade guides to High-Performance. If no LMS, add kit LMS-SHR.	1
	003928	Block Assembly, Idle Side Blade Guide		1
26	003915	Plate, Block Tilt Adjustment		1
27	003909	Block, Guide Block Mount		1
28	F05012-22	Pin, 3/16" x 5/8" Roll		2
29	F05011-3	Washer, 3/8" SAE Flat		1
30	F05011-4	Washer, 3/8" Split Lock		1
31	F05007-123	Bolt, 3/8-16 x 1 1/4" Hex Head Grade 5		1
32	F05006-102	Bolt, 5/16-18 x 3/4" Hex Head		1

REF	PART #	DESCRIPTION	COMMENTS	QTY.
33	003914	Ball, 3/16" Dia. Nylon		2
34	F05011-14	Washer, 1/4" Split Lock		2
35	F05005-15	Bolt, 1/4-20 x 1/2" Hex Head		2
36	003994	Bolt, Blade Guide Block Mount		1
37	042867	Washer, #10 Brass		1
38	F05004-240	Bolt, #10-32 x 1 1/4" Hex Head Stainless Steel		1
39	044057	Screw, Lower Block Adjustment		1
40	F05004-200	Screw, #10-32 x 3/8" Socket Head Stainless Steel		1
41	F05011-17	Washer, 5/16" SAE Flat		1
42	F05011-13	Washer, 5/16" Split Lock		1
43	052355	Block, Blade Guide Wear (Standard for 1 1/4" Blades)	052355 blocks for use with 1 1/4" blade provided as standard equipment. 052309 blocks available for optional use with 1 1/2" blades. Use kit 006382 to convert the rollers and guide blocks for both blade guides for 1 1/2" blades. EZ-Glide blocks 036347 are available for customers who prefer this block.	2
	052309	Block, Blade Guide Wear (Optional for 1 1/2" Blades)	The resaw is equipped standard with blade guide rollers that can be used with the standard 1 1/4" blade or 1 1/2" blades. Optional extended blade guide rollers are available for use with 1 1/2" blades. The extended rollers may provide more stability during difficult sawing, but will reduce the total amount of times the blade can be reused after sharpening. Use kit 006382 to convert the rollers and guide blocks for both blade guides for 1 1/2" blades.	2
	036347	Block Assembly, 1" Sq. EZ-Glide Wear		2
44	035799	Block, Blade Guide Alignment		1
45	F05011-20	Washer, #10 Split Lock		1
46	F05004-152	Screw, #10-32 x 5/8" Hex Head		1
47	044064	Adjustment Tool, Lower Guide Block		1
48	035248	Shim, .008" Blade Guide Block Spacer		1
		Drive Side Blade Guide Parts (See Section 2.2)		
49	036864	BAR WELDMENT, SHR IDLE SIDE BLADE GUIDE		1
50	F05011-9	WASHER, 1/2" SPLIT LOCK		3
51	F05008-33	BOLT, 1/2-13 X 1 1/2" HEX HEAD GRADE 5		3

2.2 Blade Guide Assembly, Drive Side

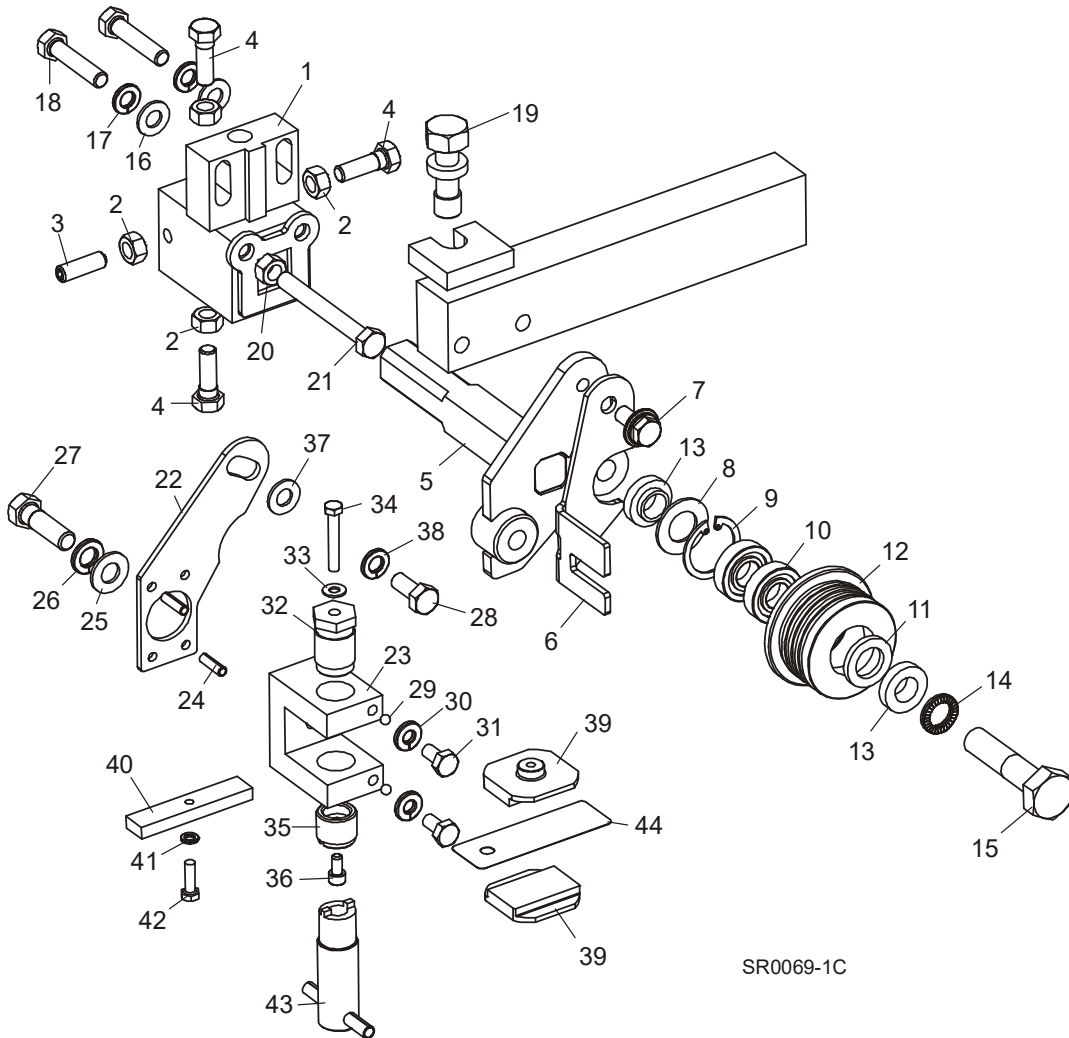

SR0069-1C

REF	PART #	DESCRIPTION	COMMENTS	QTY.
	003905	GUIDE ASSEMBLY, DRIVE SIDE BLADE ROLLER		1
	003910	Block Assembly, Blade Guide Mount		1
1	003911	Block Weldment, Blade Guide Mount	Available in assemblies only.	1
2	F05010-17	Nut, 5/16-18 Hex		4
3	F05006-122	Screw, 5/16-18 x 1" Socket Head Flat Point Stainless Steel Set		1
4	F05006-88	Bolt, 5/16-18 x 1" Hex Head Stainless Steel		3
5	003913	Shaft Weldment, Drive Side Guide		1
6	003916	Plate, Blade Guide Deflector		1
7	F05006-101	Bolt, 5/16-18 x 3/4" Hex Head w/Flat & Lock Washer		1

REF	PART #	DESCRIPTION	COMMENTS	QTY.
	A04925	Roller Assembly, Blade Guide (standard for use with 1 1/4" & 1 1/2" blades)	The resaw is equipped standard with blade guide rollers that can be used with the standard 1 1/4" blade or 1 1/2" blades. Optional extended blade guide rollers are available for use with 1 1/2" blades. The extended rollers may provide more stability during difficult sawing, but will reduce the total amount of times the blade can be reused after sharpening. Use kit 006382 to convert the rollers and guide blocks for both blade guides for 1 1/2" blades.	1
	014299	Roller Assembly, Extended Blade Guide (optional for use with 1 1/2" blades)		1
	K07079	Bearing Kit, Blade Guide Rebuild		1
8	P04252	Washer, 5/8" White Felt		1
9	F04254-1	Ring, 1 1/8" Interior Retaining		1
10	015975	Bearing, R8-2RS Blade Guide	Available in assemblies only.	2
11	P06455	Washer, 5/8" Gray Felt		1
	F05005-105	Screw, 1/4-28 x 1/4" Socket Head Cup Point Set Black Oxide		1
	057407-1507	Instruction Sheet, Blade Guide Rebuild		1
12	S04250	Roller, Flanged Blade Guide (1 1/4" & 1 1/2" blade)	Available in assemblies only.	1
	014298	Roller, Flanged Blade Guide (1 1/2" blade)	Available in assemblies only.	1
	A04925-364	Instruction Sheet, Blade Guide Roller Replacement		1
13	S04253	Spacer, Blade Guide		2
14	F05011-125	Washer, 1/2" Nord-Lock		1
15	F05008-10	Bolt, 1/2-13 x 2 1/4" Hex Head Grade 5		1
16	F05011-17	Washer, 5/16" SAE Flat		2
17	F05011-13	Washer, 5/16" Split Lock		2
18	F05006-76	Bolt, 5/16-18 x 1 1/2" Hex Head		2
19	035656	Bolt, Blade Guide Vertical Adjustment		1
20	F05010-17	Nut, 5/16-18 Hex		1
21	F05006-136	Bolt, 5/16-18 x 2 3/4" Hex Head Full Thread		1
	006340	GUIDE KIT, HIGH-PERFORMANCE BLADE GUIDE (OPTIONAL)	High-Performance Blade Guide Kit requires LMS blade lube system. If resaw already equipped with LMS, use kit 006340 to upgrade both drive and idle side blade guides to High-Performance. If no LMS, add kit LMS-SHR.	1
	003927	Block Assembly, Drive Side Blade Guide		1
22	003915	Plate, Block Tilt Adjustment		1
23	003909	Block, Guide Block Mount		1
24	F05012-22	Pin, 3/16" x 5/8" Roll		2
25	F05011-3	Washer, 3/8" SAE Flat		1
26	F05011-4	Washer, 3/8" Split Lock		1
27	F05007-123	Bolt, 3/8-16 x 1 1/4" Hex Head Grade 5		1
28	F05006-102	Bolt, 5/16-18 x 3/4" Hex Head		1

REF	PART #	DESCRIPTION	COMMENTS	QTY.
29	003914	Ball, 3/16" Dia. Nylon		2
30	F05011-14	Washer, 1/4" Split Lock		2
31	F05005-15	Bolt, 1/4-20 x 1/2" Hex Head		2
32	003994	Bolt, Blade Guide Block Mount		1
33	042867	Washer, #10 Brass		1
34	F05004-240	Bolt, #10-32 x 1 1/4" Hex Head Stainless Steel		1
35	044057	Screw, Lower Block Adjustment		1
36	F05004-200	Screw, #10-32 x 3/8" Socket Head Stainless Steel		1
37	F05011-17	Washer, 5/16" SAE Flat		1
38	F05011-13	Washer, 5/16" Split Lock		1
39	052355	Block, Blade Guide Wear (Standard for 1 1/4" Blades)	052355 blocks for use with 1 1/4" blade provided as standard equipment. 052309 blocks available for optional use with 1 1/2" blades. Use kit 006382 to convert the rollers and guide blocks for both blade guides for 1 1/2" blades. EZ-Glide blocks 036347 are available for customers who prefer this block.	2
	052309	Block, Blade Guide Wear (Optional for 1 1/2" Blades)		2
	036347	Block Assembly, 1" Sq. EZ-Glide Wear		2
40	035799	Block, Blade Guide Alignment		1
41	F05011-20	Washer, #10 Split Lock		1
42	F05004-152	Screw, #10-32 x 5/8" Hex Head		1
43	044064	Adjustment Tool, Lower Guide Block		1
44	035248	Shim, .008" Blade Guide Block Spacer		1
		Idle Side Blade Guide Parts (See Section 2.1)		

SECTION 3 BLADE WHEELS & DRIVE

3.1 Blade Drive Assembly

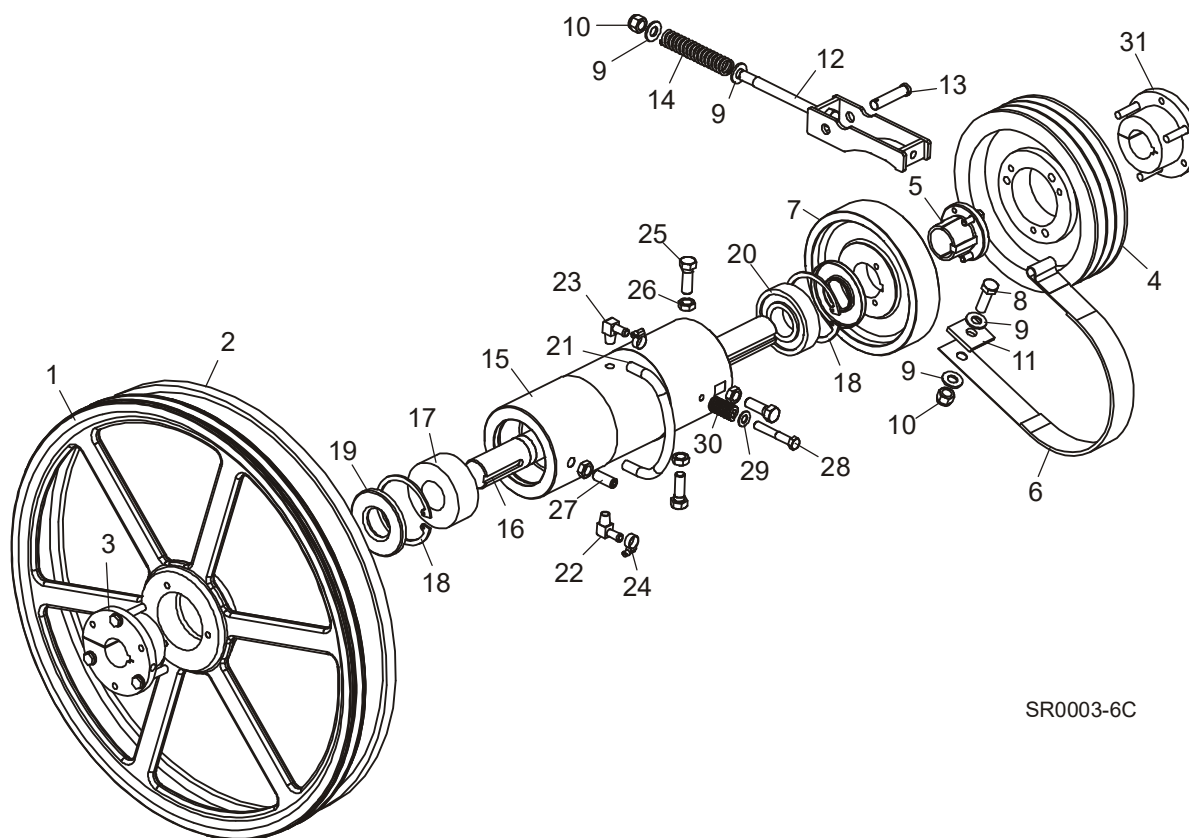

SR0003-6C

REF	PART #	DESCRIPTION	COMMENTS	QTY.
1	036827	SHEAVE, 24" SHR "V"GROOVE		1
2	017922-1	BELT, B72.5		1
3	016532	BUSHING, SF X 1 9/16"		1
4	007349	SHEAVE, 3/5V X 9.25SF (HR300EC25-1/HR300EB25-1 60HZ ONLY)		1
	036929	SHEAVE, 3/5V X 9.75SF (HR300EC20-1/HR300EB20-1 60HZ ONLY)		1
	006320	SHEAVE, 3/5V5.5SDS (HR300EC20-1/HR300EB20-1 50HZ ONLY)		1
	038845	SHEAVE, 2B8.6SK (HR300EA10-1 ONLY)		1
5	014003	BUSHING, P1 1-9/16 SPLIT TAPER		1
6	014391	BAND, UPPER PIVOT BRAKE		1
7	014000	PULLEY, BRAKE		1
8	F05008-33	BOLT, 1/2-13 X 1 1/2" HEX HEAD GRADE 5		1
9	F05011-2	WASHER, 1/2" SAE FLAT		4
10	F05010-8	NUT, 1/2-13 HEX NYLON LOCK		2
11	S04195	PLATE, 1/4" X 1 3/4" X 1 3/4" BRAKE STRAP		1
12	036953	BRAKE LINK WELDMENT, SHR		1
13	F05012-81	PIN, 1/2" X 2 1/4" CLEVIS		1
14	036954	SPRING, .88" X 4.31" X .125"		1
	036925	BEARING ASSEMBLY, SHR		1

REF	PART #	DESCRIPTION	COMMENTS	QTY.
15	036927	Housing, SHR Cylindrical Bearing		1
16	036928	Shaft, SHR Drive		1
17	036926	Bearing, MU5308TV		1
18	F04254-17	Ring, 90mm I17 IR Retaining		2
19	P10206	Seal, CR15890		2
20	016055	Bearing, 6308 C3, Open		1
21	016394	Tube, Oil Level		1
22	016330	Fitting, 1/4" NPT x 3/8" Hose Barb, Elbow		2
23	016331	Fitting, 1/4" NPT x 3/8" Hose Barb, Vented Elbow		1
24	P649	Hose Clamp, 7/32"-5/8"		2
25	F05008-53	BOLT, 1/2-20 X 1 1/2" HEX HEAD GRADE 5		3
26	F05010-16	NUT, 1/2-20 HEX JAM		4
27	F05004-170	BOLT, 1/2-20 X 1 1/2" STAINLESS STEEL CONE POINT		1
28	F05007-125	BOLT, 3/8-16 X 2-1/2" HEX HEAD GRADE 5		1
29	F05011-3	WASHER, 3/8" FLAT SAE		1
30	034430	SPRING, 3/4" OD X 1 1/2" DIE		1
31	016532	BUSHING, SF X 1 9/16" (HR300EC20-1/HR300EB20-1/HR300EC25-1/HR300EB25-1 60HZ ONLY)		1
	033249	BUSHING, SDS X 1 5/8" (HR300EC20-1/HR300EB20-1 50HZ ONLY)		1
	014690	BUSHING, SK X 1 9/16" (HR300EA10-1 ONLY)		1

3.2 Drive Belt Covers and Brake Solenoid

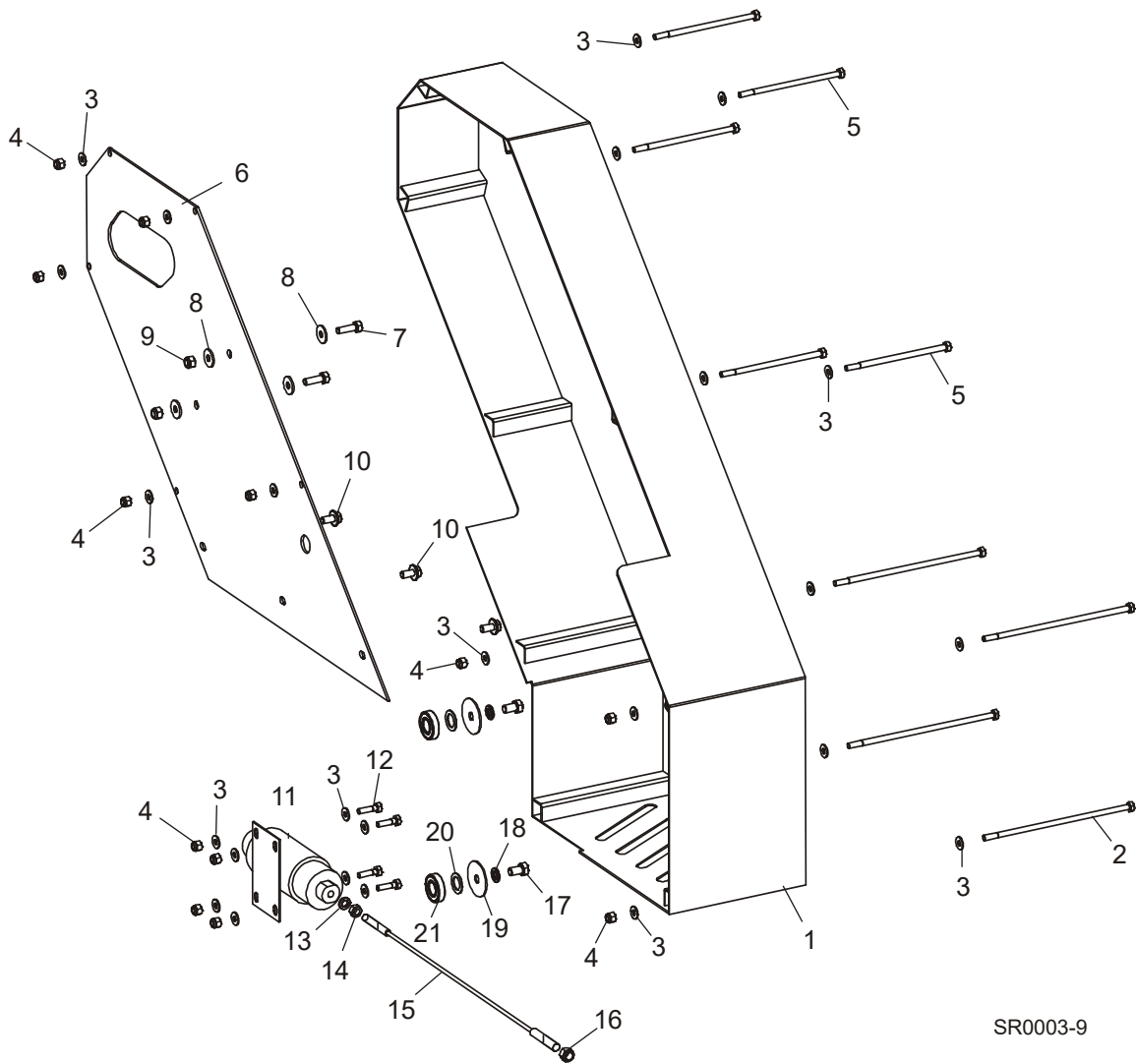

SR0003-9

REF	PART #	DESCRIPTION	COMMENTS	QTY.
1	036935	GUARD WELDMNT, SHR		1
2	F05005-173	BOLT, 1/4-20 X 8" HEX HEAD GRADE 5		4
3	F05011-11	WASHER, 1/4" SAE FLAT		26
4	F05010-69	NUT, 1/4-20 NYLON LOCK		13
5	F05005-82	BOLT, 1/4-20 X 5 1/2" HEX HEAD GRADE 5		5
6	036896	PLATE, REAR GUARD		1
7	F05006-27	BOLT, 5/16-18 X 1" HEX HEAD GRADE 5		2
8	F05011-16	WASHER, 5/16" STANDARD FLAT		4
9	F05010-58	NUT, 5/16-18 HEX NYLON LOCK		2
10	F05006-101	BOLT, 5/16-18 X 3/4" HEX HEAD W/FLAT & LOCK WASHER		3
11	038442	SOLENOID, 39#, 24VDC		1
12	F05005-101	BOLT, 1/4-20 X 1" HEX HEAD GRADE 5		4
13	F05011-13	WASHER, 5/16" SPLIT LOCK		1
14	F05010-28	NUT, 5/16-24 HEX		1
15	038460	CABLE, SHR BRAKE		1
16	F05010-10	NUT, 3/8-16 HEX NYLON LOCK		1

REF	PART #	DESCRIPTION	COMMENTS	QTY.
17	F05004-124	BOLT, 3/8-16 X 1/2" HEX HEAD GRADE 5		2
18	F05011-4	WASHER, 3/8" SPLIT LOCK		2
19	036931	WASHER, .39" X 1.75" X 14GA		2
20	016510	SHIM, 5/8" X 1" X 1/16"		2
21	P04156	BEARING, R-10		2

3.3 Blade Motor Assembly (20HP)

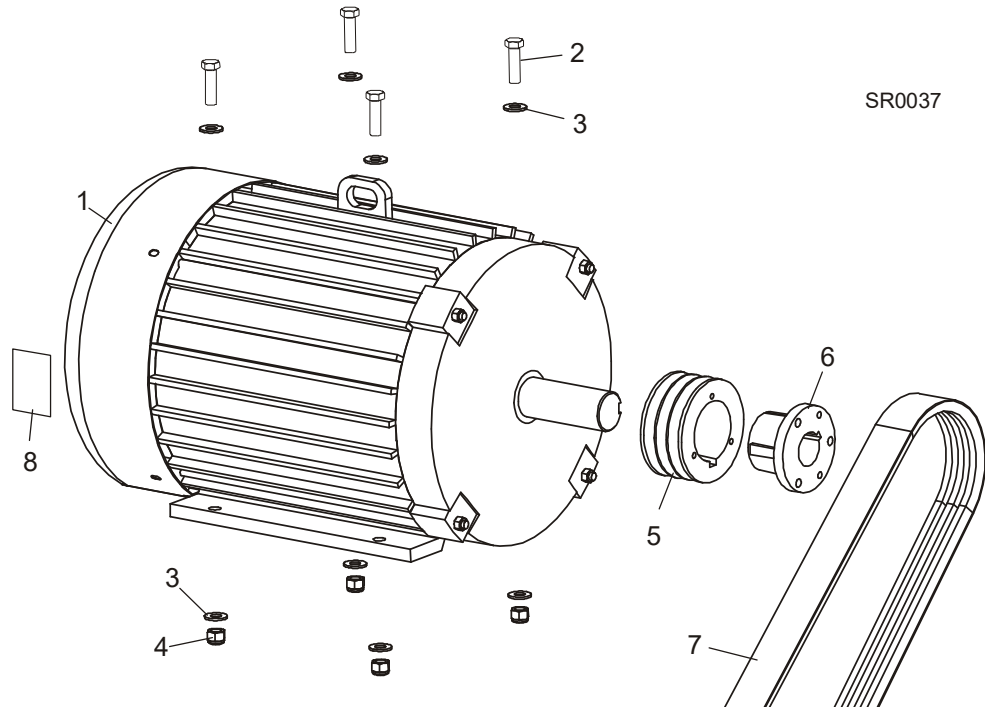

REF	PART #	DESCRIPTION	COMMENTS	QTY.
	038489	MOTOR ASSEMBLY, 20HP SINGLE HEAD RESAW		1
1	074144	Motor, Lincoln 20HP 1775 RPM (HR300EB20-1, HR300EC20-1, HR300EH20-1 Only)		1
2	F05008-88	Bolt, 1/2-13 x 1 3/4" Hex Head Grade 5		4
3	F05011-2	Washer, 1/2" SAE Flat		8
4	F05010-8	Nut, 1/2-13 Hex Nylon Lock		4
5	034560	Sheave, 3/5V4.9 Drive (20HP Motor Only)		1
6	034503	Bushing, Q1 x 1 5/8" (20HP Motor Only)		1
	042353	Bushing, Q1 x 1 7/8" (25HP Motor Only Rev. A1.00 - A1.03)		1
7	038478	Belt, 3/5V800 Drive		1
		Driven Sheave & Bushing (See Section 3.1)		
8	S20097	DECAL, MOTOR DIRECTION		1

3.4 Blade Motor Assembly (25HP)

TD-038488_001

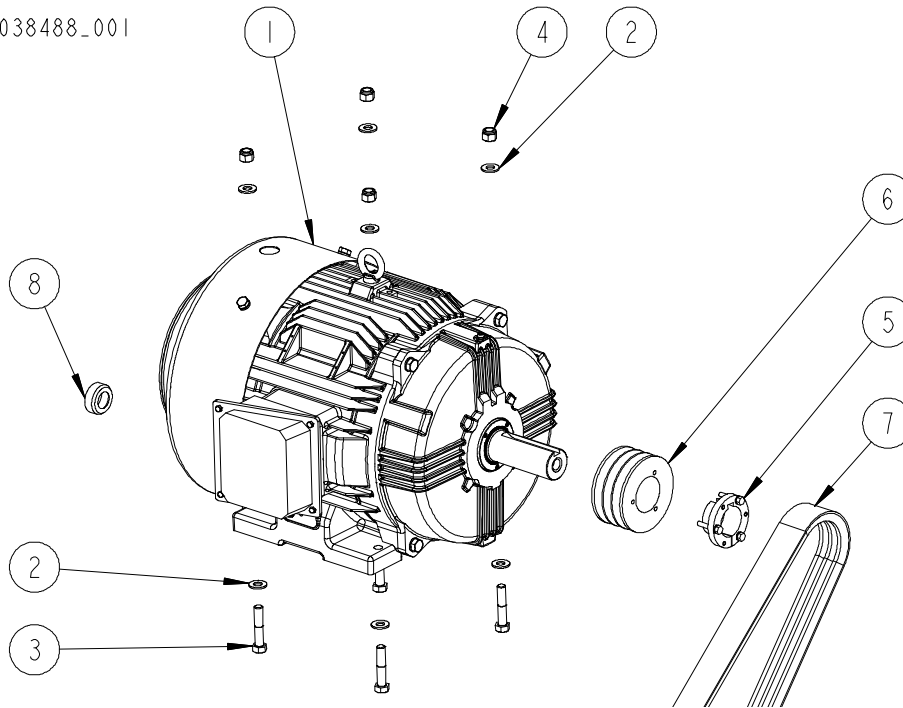

REF	PART #	DESCRIPTION	COMMENTS	QTY.
	038488	MOTOR ASSY, 25HP HR300/SHR		1
1	130056	Motor, 25HP 1800RPM Marathon Premium Eff		1
2	F05011-2	Washer, 1/2" SAE Flat		8
3	F05008-74	BOLT, HEX HEAD 112-13x2 1/2 GR5 ZINC		4
4	F05010-8	Nut, 1/2-13 Nyl Hex Lock		4
5	007351	Bushing, SDSx1 7/8		1
6	007350	Sheave, 3/5V4.65 Drive		1
7	038478	Belt, 3/5V800 Drive		1
8	038664	Bushing, 1 1/2-1 Reducer		1
		Driven Sheave & Bushing (See Section 3.1)		

3.5 Blade Motor Assembly (10HP)

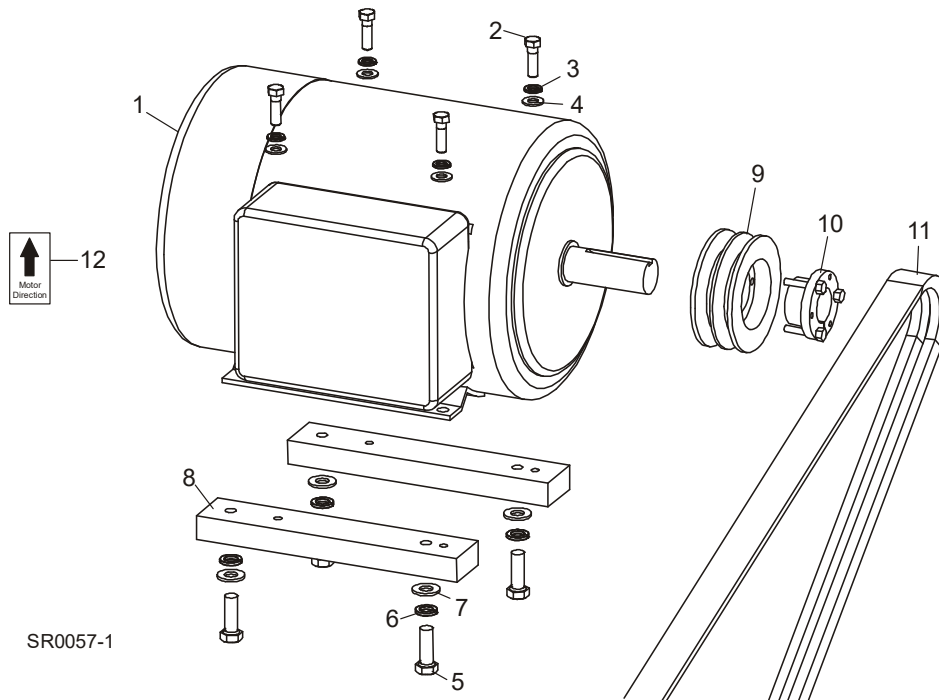

REF	PART #	DESCRIPTION	COMMENTS	QTY.
	038490	MOTOR ASSEMBLY, 10HP SINGLE HEAD RESAW		1
1	038487	Motor, Lincoln 10HP 1725 RPM Single Phase		1
2	F05007-123	Bolt, 3/8-16 x 1 1/4" Hex Head Grade 5		4
3	F05011-4	Washer, 3/8" Split Lock		4
4	F05011-3	Washer, 3/8" SAE Flat		4
5	F05008-33	Bolt, 1/2-13 x 1 1/2" Hex Head Grade 5		4
6	F05011-9	Washer, 1/2" Split Lock		4
7	F05011-2	Washer, 1/2" SAE Flat		4
8	038661	Spacer, 10HP SHR Motor		2
9	P21003	Sheave, 2B4.0SH		1
10	P21001	Bushing, SH x 1 3/8"		1
11	P10277-2	Belt, 2BX74 Drive		1
		Driven Sheave & Bushing (See Section 3.1)		
12	S20097	DECAL, MOTOR DIRECTION		1

3.6 Idle Blade Wheel Assembly

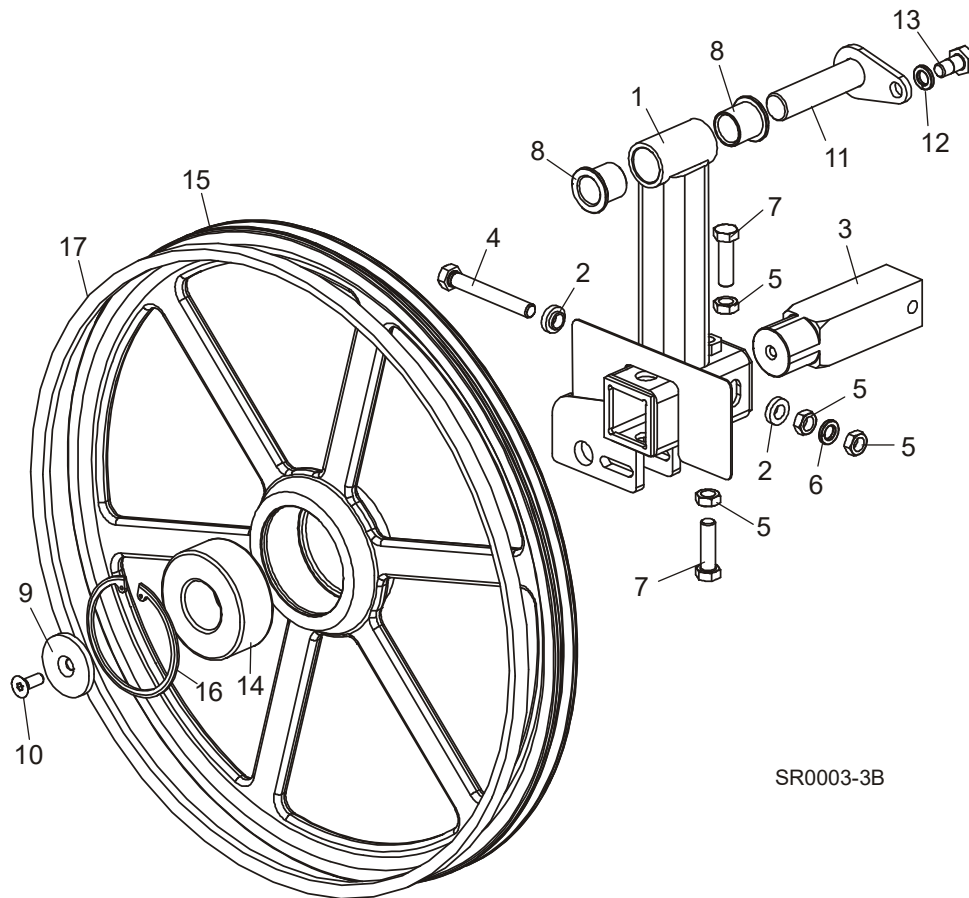

SR0003-3B

REF	PART #	DESCRIPTION	COMMENTS	QTY.
	036877	IDLER ASSEMBLY, SHR		1
1	036874	Idler Weldment, SHR		1
2	S04253	Spacer, .510" x .937" x .34"		2
3	016398	Shaft, 1 3/4" Idler, 3/8" Retainer		1
4	F05008-111	Bolt, 1/2-20 x 3 3/4" Hex Head Full Thread Grade 2		1
5	F05010-16	Nut, 1/2-20 Hex Jam		4
6	F05011-9	Washer, 1/2" Split Lock		1
7	F05008-127	Bolt, 1/2-20 x 1 3/4" Hex Head Full Thread		2
8	P109	Bushing, 1" ID x 1-1/4" OD Flanged		2
9	016397	Retainer, 13/32" I.D. x 2 1/4" O.D. x 1/4"		1
10	F05007-64	Screw, 3/8-16 x 1" Socket Head		1
11	042232	PIN WELDMENT, SIDE SUPPORT		1
12	F05011-9	WASHER, 1/2" SPLIT LOCK		1
13	F05008-50	BOLT, 1/2-13 X 1 HEX HEAD GRADE 2		1
	017835	WHEEL ASSEMBLY, 24 IDLE, BELTED		1
14	016014	Bearing, 5309-2RS		1
15	034871	Sheave, 24" Idler "V"Groove		1
16	F04254-28	Ring, 100mm Internal Beveled		1
17	017922-1	BELT, B72.5		1

SECTION 4 SAW HEAD

4.1 Blade Tensioner Assembly

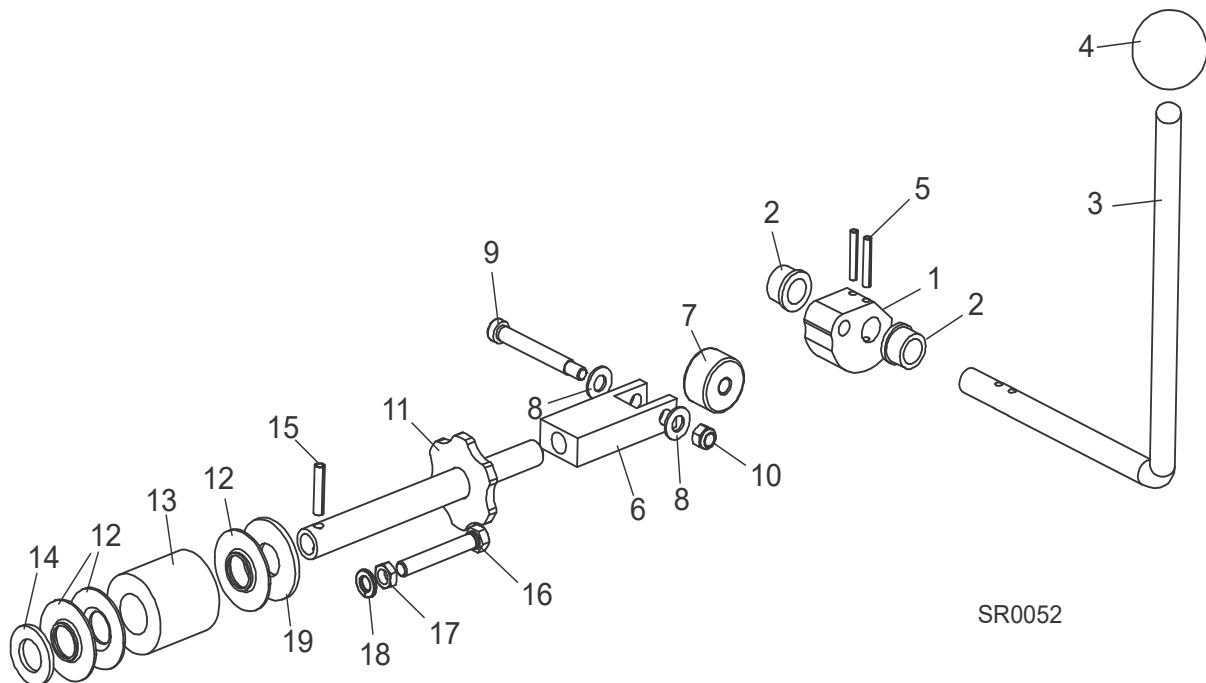

SR0052

REF	PART #	DESCRIPTION	COMMENTS	QTY.
	038643	TENSION ASSEMBLY, CAM ACTUATED BLADE		1
1	049104	Cam, Tension		1
2	P05135	Bushing, 5/8" x 7/8" x 1/2" Bronze		2
3	048804	Handle, Blade Tensioner		1
4	P04211	Knob, 5/8-18 Ball		1
5	F05012-16	Pin, 3/16" x 1 1/4" Roll		2
6	128072	Block, Tensioner Bearing Mount	Bearing Mount 049321 was replaced with 128072 on 10/16/2019 per ECN 36137.	1
7	048219	Cam Follower, 3/8" x 1 3/8" x 13/16"		1
8	F05011-3	Washer, 3/8" SAE Flat		2
9	F05007-202	Bolt, 3/8 x 2 1/2" Socket Head Shoulder		1
10	F05010-58	Nut, 5/16-18 Hex Nylon Lock		1
11	038642	Shaft Weldment, Blade Tension		1
12	014925	Guide, Tension Handle		3
13	014828	Spring, Rubber Tensioner Blade		1
14	F05011-62	Washer, 3/4" SAE Flat		1
15	F05012-12	Pin, 1/4" x 1 1/4" Roll		1
16	F05007-157	Bolt, 3/8-16 x 2 1/2" Hex Head Full Thread		1
17	F05010-29	Nut, 3/8-16 Jam		1
18	F05011-4	Washer, 3/8" Split Lock		1
19	F05011-29	Washer, 3/4" USS Flat		1

4.2 Middle Throat Screw

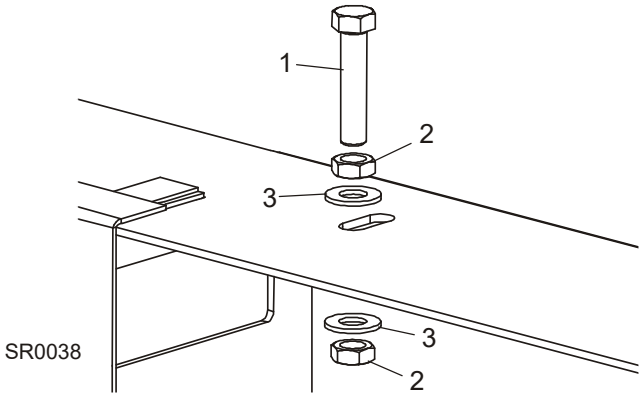

REF	PART #	DESCRIPTION	COMMENTS	QTY.
1	F05007-129	BOLT, 3/8-16 X 1 3/4" HEX HEAD GRADE 5		1
2	F05010-29	NUT, 3/8-16 JAM		2
3	F05011-3	WASHER, 3/8" FLAT SAE		2

4.3 Water Lube Assembly

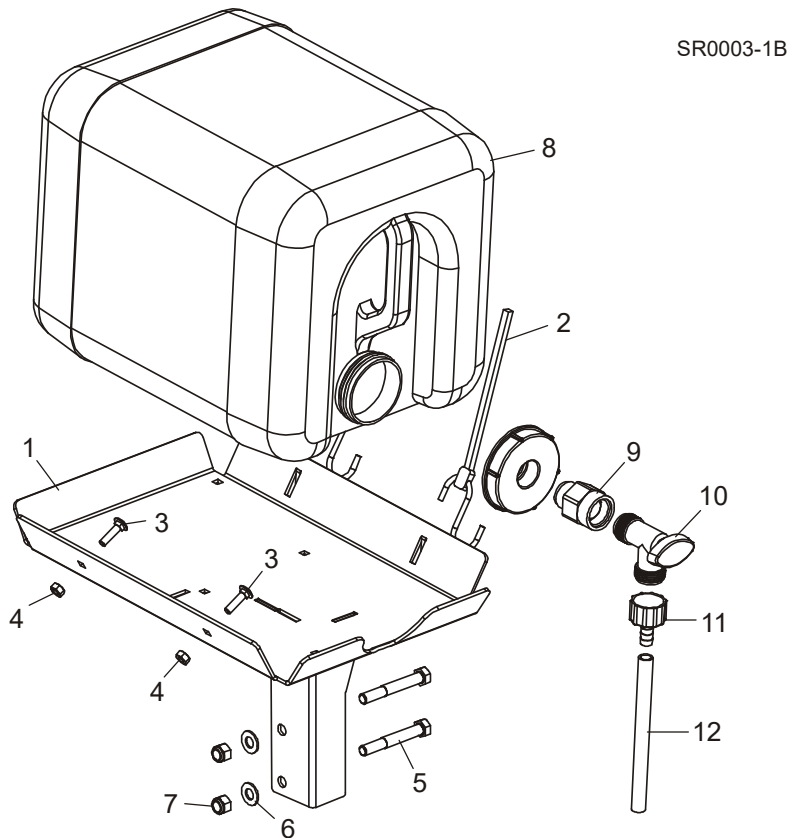

SR0003-1B

REF	PART #	DESCRIPTION	COMMENTS	QTY.
	048599	TRAY ASSEMBLY, LT28 WATER BOTTLE		1
1	048600	Tray Weldment, LT28 Water Bottle		1
2	P11668	Strap, 20" Rubber w/Hook		2
3	F05005-34	Bolt, 1/4-20 X 1" Carriage Head		2
4	F05010-21	Nut, 1/4-20 Hex Lock		2
5	F05007-29	Bolt, 3/8-16 x 2 3/4" Hex Head		2
6	F05011-3	Washer, 3/8" Flat SAE		2
7	F05010-10	Nut, 3/8-16 Hex Nylon Lock		2
8	014642	Bottle Assembly, Water Lube w/Cap		1
	061372	O-ring, Water Bottle Cap	If the water bottle cap keeps leaking, add this o-ring to the cap. Leave the existing o-ring installed.	1
9	014636	Fitting, 3/4" FPT x 3/4" MPT		1
10	014100	Valve, 5/8" 90 deg. Male Shutoff		1
11	014113	Fitting, 5/8-3/8 Hose Barb		1
12	R01885	Hose, Water Lube Stock		6 ft.

4.4 Covers & Sawdust Chute

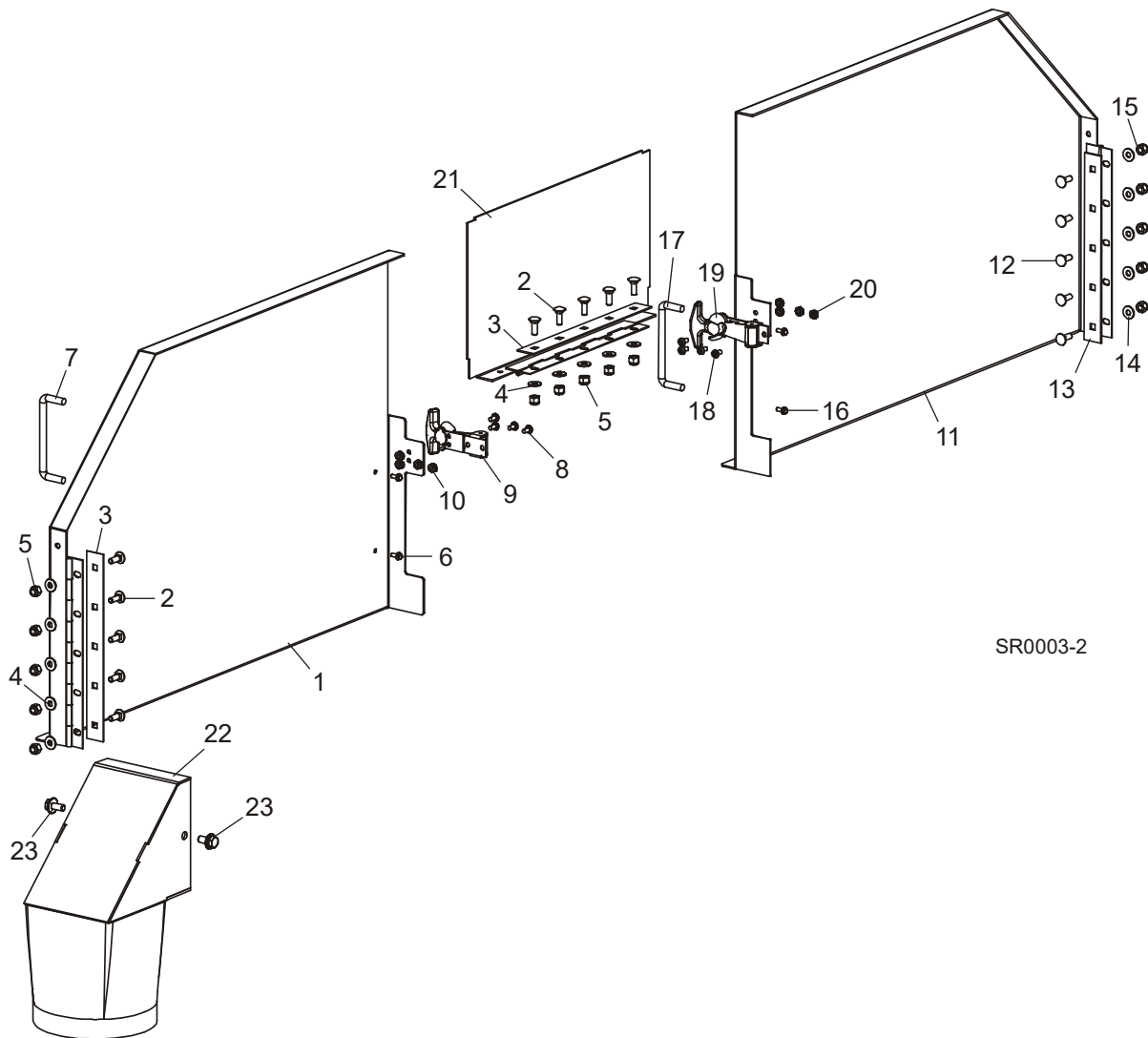

SR0003-2

REF	PART #	DESCRIPTION	COMMENTS	QTY.
	036922	COVER ASSEMBLY, SHR DRIVE SIDE		1
1	036879	Door Weldment, SHR Drive Side		1
2	F05005-113	Bolt, 1/4-20 x 3/4" Carriage		5
3	034251	Plate, Hinge Backing		1
4	F05011-11	Washer, 1/4" SAE Flat		5
5	F05010-69	Nut, 1/4-20 Nylon Lock		5
6	F05015-8	Bolt, #8-32 x 3/8" Self Tap		2
7	P08065	Handle, 4" w/Bolts		1
8	F05004-3	Screw, #10-24 x 3/8" Phillips		4
9	014829	Latch, Flexible Draw		1
10	F05010-14	Nut, #10-24 Keps		4
	036921	COVER ASSEMBLY, SHR IDLE SIDE		1
11	036879	Door Weldment, SHR Drive Side		1
12	F05005-113	Bolt, 1/4-20 x 3/4" Carriage		5
13	034251	Plate, Hinge Backing		1
14	F05011-11	Washer, 1/4" SAE Flat		5

4 Replacement Parts
Covers & Sawdust Chute

REF	PART #	DESCRIPTION	COMMENTS	QTY.
15	F05010-69	Nut, 1/4-20 Nylon Lock		5
16	F05015-8	Bolt, #8-32 x 3/8" Self Tap		2
17	P08065	Handle, 4" w/Bolts		1
18	F05004-3	Bolt, #10-24 x 3/8" Phillips		4
19	014829	Latch, Flexible Draw		1
20	F05010-14	Nut, #10-24 Keps		4
21	036895	COVER WELDMENT, SHR MIDDLE		1
22	036943	EXTENSION WELDMENT, SHR DUST CHUTE		1
23	F05006-101	BOLT, 5/16-18 X 3/4" HEX HEAD W/FLAT & LOCK WASHER		2

4.5 Saw Head Decals

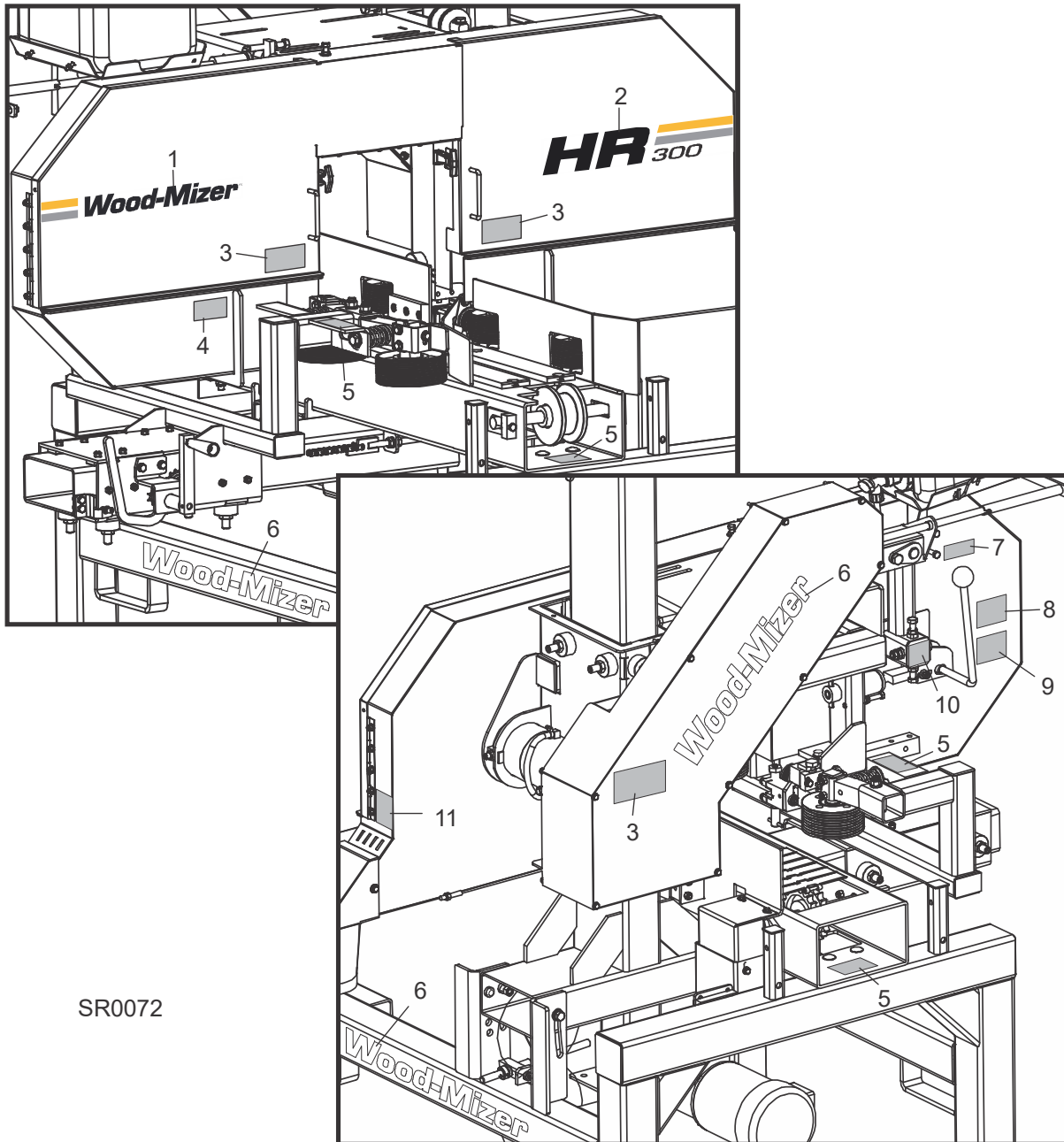

SR0072

REF	PART #	DESCRIPTION	COMMENTS	QTY.
1	076273	DECAL, BLADE COVER WOOD-MIZER LOGO		1
2	076278	DECAL, HR300 LOGO		1
3	033254	DECAL, MOVING PARTS DANGER		3
4	S11752	DECAL, BLADE DANGER ARROW		1
5	S12641	DECAL, PINCH POINT WARNING		4
6	065034	DECAL, WOOD-MIZER LOGO 20.5" WHITE		3
7	P12879	DECAL, RE-SHARP		1
8	049368	DECAL, TENSION INFO		1
9	049367	DECAL, TENSIONER WARNING		1
10	P11789	DECAL, BLADE ALIGNMENT		1

4 Replacement Parts
Saw Head Decals

REF	PART #	DESCRIPTION	COMMENTS	QTY.
11	P11754	DECAL, SAWDUST CHUTE WARNING		1

SECTION 5 UP/DOWN

5.1 Mast Assembly

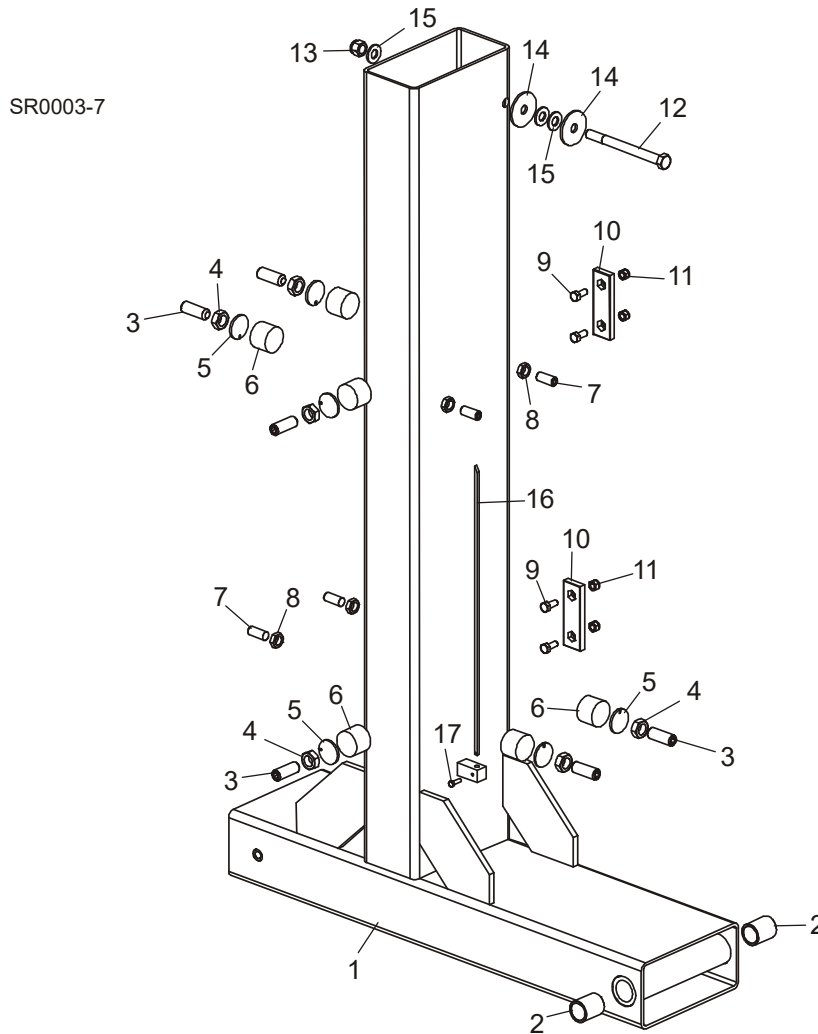

REF	PART #	DESCRIPTION	COMMENTS	QTY.
1	036916	UPRIGHT WELDMENT, SHR		1
2	P05041	BUSHING, 1" X 1 1/4" X 1 1/2" BRONZE		2
3	F05009-27	SCREW, 5/8-18 X 1 3/4" SOCKET HEAD		6
4	F05010-11	NUT, 5/8-18 HEX JAM		6
5	042432	PAD, NYLON BACKING		6
6	033098	PAD, ROUND NYLON		6
7	F05008-18	BOLT, 1/2-13 X 1 1/4" BRASS TIP STAINLESS STEEL		4
8	F05010-31	NUT, 1/2-13 JAM		4
9	F05006-5	BOLT, 5/16-18 X 3/4" HEX HEAD GRADE 2		4
10	M04096	PADS, DELRIN UP/DOWN SLIDE		2
11	F05010-58	NUT, 5/16-18 HEX NYLON LOCK		4
12	F05008-28	BOLT, 1/2-13 X 5 1/2" HEX HEAD GRADE 5		1
13	F05010-8	NUT, 1/2-13 HEX NYLON LOCK		1
14	F05011-38	WASHER, 1/2" X 2" FENDER		2
15	F05011-2	WASHER, 1/2" SAE FLAT		3

5 Replacement Parts
Mast Assembly

REF	PART #	DESCRIPTION	COMMENTS	QTY.
16	S22636	POINTER, MH BLADE HEIGHT STRAIGHT		1
17	F05004-18	SCREW, 10-24 X 5/8" HEX HEAD		1

5.2 Up/Down System Assembly

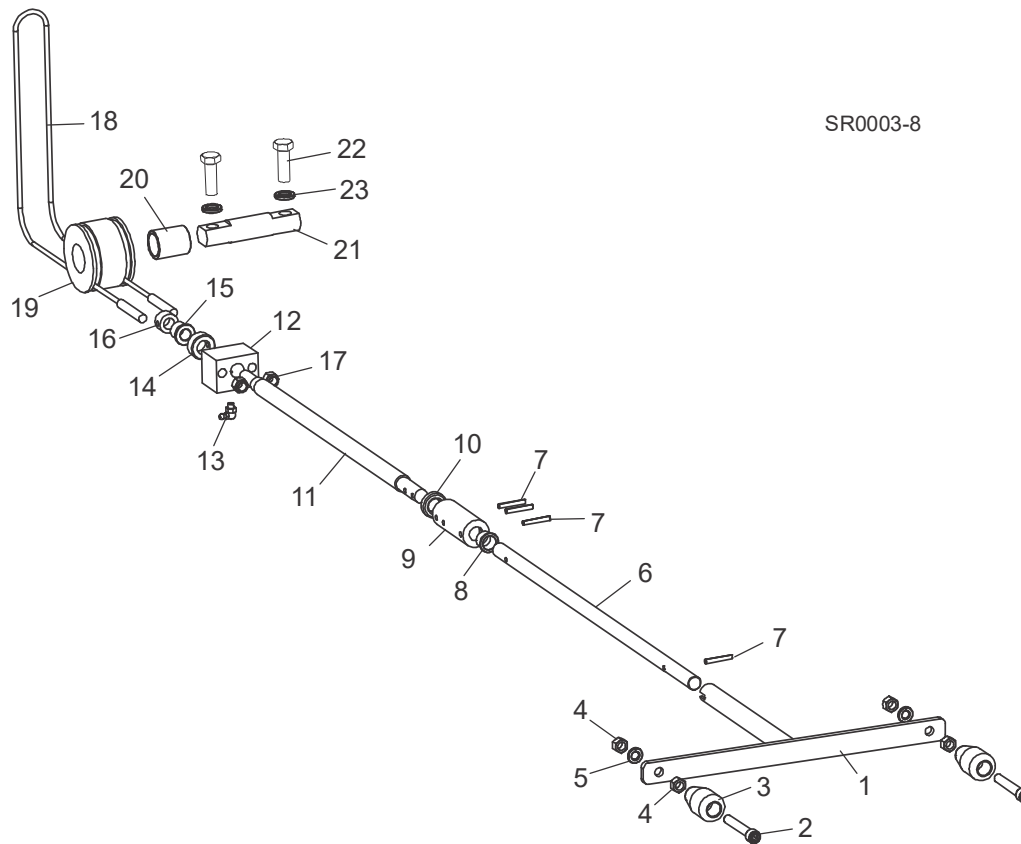

SR0003-8

REF	PART #	DESCRIPTION	COMMENTS	QTY.
	033251	HANDLE ASSEMBLY, UP/DOWN CRANK		1
1	033253	Handle Weldment, Crank		1
2	F05007-111	Screw, 3/8-16 x 3 1/2" Socket Head Cap		2
3	060170	Knob, 3/8" Bore Tapered Plastic		2
4	F05010-29	Nut, 3/8-16 Jam		4
5	F05011-4	Washer, 3/8" Split Lock		2
	130147	ASSY, HR300 SHR HEIGHT ADJUST	130147 added after 3/15/2022 per ECN 38431.	1
6	036949	Shaft, Head Crank, SHR		1
7	F05012-16	Pin, 3/16" x 1 1/4" Roll		4
8	P22478	Bushing, .635" I.D. x 3/4" O.D. Nylon Flanged		1
9	S22476	Coupling, Up/Down Crank		1
10	130128	Bearing, Thrust 51102 15mm x 28mm x 9mm	130128 replaced P04214 after 3/15/2022 per ECN 38431.	1
	P04214	BEARING, 5/8" THRUST		1
11	130141	Rod, Height Adjustment	130141 replaced S22208 after 3/15/2022 per ECN 38431.	1
	S22208	Rod, Height Adjustment		1
12	S22209	Block, Height Adjustment		1
13	P04108	Fitting, Grease 90 Deg. 1/4-28		1
14	P05035	Collar, 5/8" I.D. Lock		1
15	P22317	BUSHING, 1/2" X 3/4" BRONZE FLANGED		1
16	014820	Collar, 1/2" I.D. X 7/8" O.d. Lock		1
17	F05010-10	NUT, 3/8-16 HEX NYLON LOCK		2

5 Replacement Parts
Up/Down System Assembly

REF	PART #	DESCRIPTION	COMMENTS	QTY.
18	S22307	CABLE, UP/DOWN RESAW		1
19	S22205	PULLEY, 2-GROOVED CABLE		1
20	P05041	BUSHING, 1" X 1 1/4" X 1 1/2" BRONZE		1
21	S22203	PIN, CABLE ROLLER		1
22	F05008-33	BOLT, 1/2-13 X 1 1/2" HEX HEAD GRADE 5		2
23	F05011-9	WASHER, 1/2" SPLIT LOCK		2

SECTION 6 FEED

6.1 Feed Track Assembly

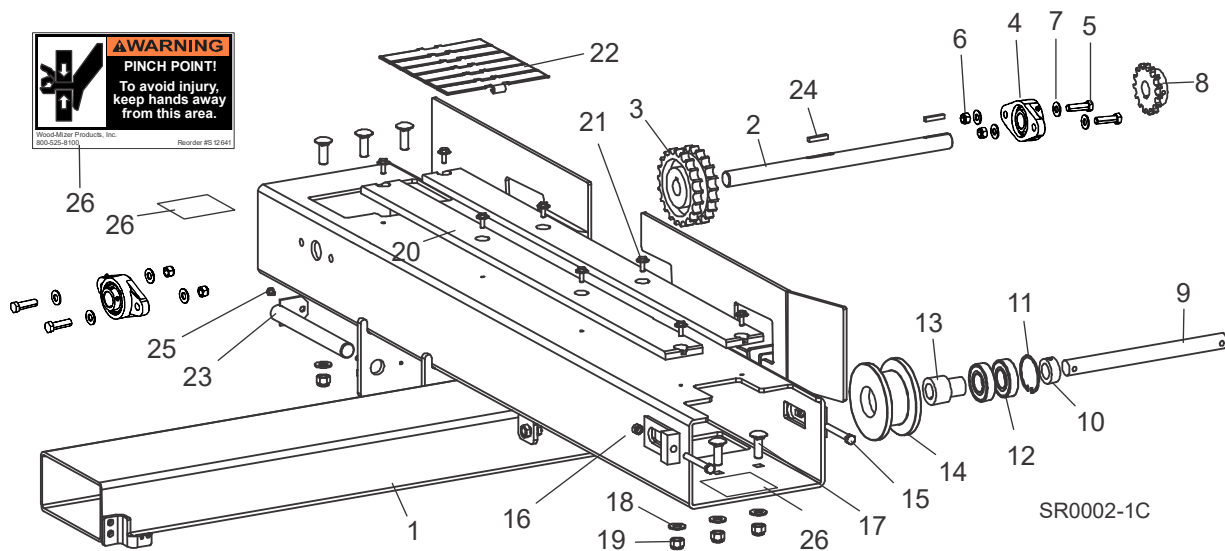

REF	PART #	DESCRIPTION	COMMENTS	QTY.
1	054349	TUBE WELDMENT, DRIVE CHAIN		1
2	054372	SHAFT, CHAIN DRIVE		1
3	P20202	SPROCKET, 21-22T FEED		1
4	038124	BEARING, 1 FLANGED, VF2S 216		2
5	F05007-156	BOLT, 7/16-20X1 1/2 HH GR5		4
6	F05010-83	NUT, 7/16-20 NYL LOCK	Added after 4/25/2022 per ECN 38511	4
7	F05011-43	WASHER, 7/16 SAE FLAT 15/16 OD	Added after 4/25/2022 per ECN 38511	8
8	054172	SPROCKET, 50-15 X 1"		1
9	S22425	SHAFT, MULTIHEAD FEED IDLER		1
10	038090	COLLAR, 1" LOCK		1
11	F04254-12	RING, 62MM IR RETAINING		1
12	P11035	BEARING, 6206-2NSE		2
13	S20286	BUSHING, FEED IDLER		1
14	S20282	PULLEY, FEED IDLER		1
15	F05007-1	BOLT, 3/8-16 X 3" HEX HEAD FULL THREAD		2
16	F05010-1	NUT, 3/8-16 HEX		2
17	F05008-150	BOLT, 1/2-13 X 1-1/2" CARRIAGE		6
18	F05011-2	WASHER, 1/2" SAE FLAT		6
19	F05010-8	NUT, 1/2-13 HEX NYLON LOCK		6
20	054373	STRIP, 40-7/8 X 2-3/4" PRE-DRD TYVAR		2
21	F05005-134	BOLT, 1/4-20 X 3/4" HEX HEAD W/CONICAL WASHER		8
22	054374	CHAIN, 7-1/2" X 105" FLAT FEED TRACK		1
23	054427	POST WELDMENT, CONTROL		1
24	017832	KEY, 1/4SQ X 1 3/8		2
25	F05005-15	BOLT, 1/4-20 X 1/2" HEX HEAD		1
26	S12641	DECAL, PINCH POINT WARNING		2

6.2 Feed Motor Assembly

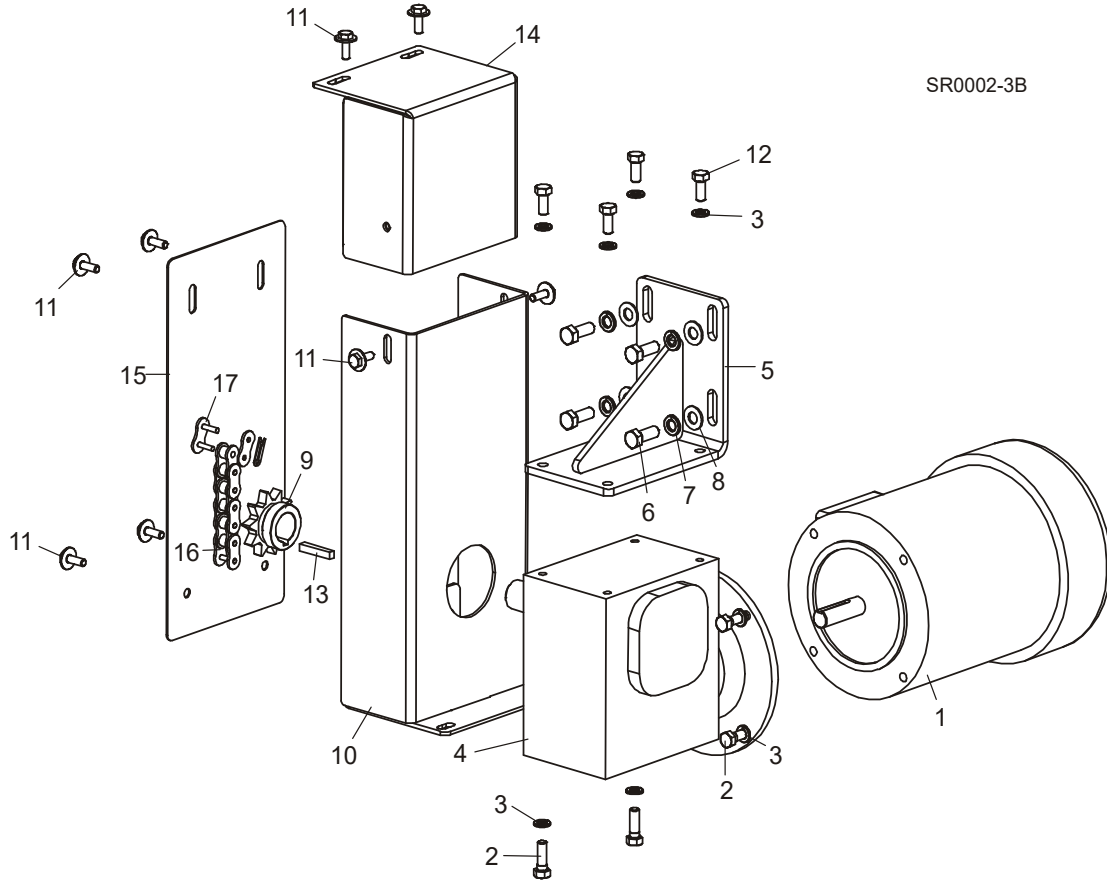

REF	PART #	DESCRIPTION	COMMENTS	QTY.
1	047486	MOTOR, 1HP AC FEED		1
2	F05006-1	BOLT, 5/16-18 X 1" HEX HEAD GRADE 2		6
3	F05011-13	WASHER, 5/16" SPLIT LOCK		10
4	054363	GEARBOX, 90 DEG. BMQ220 RIGHT		1
5	054435	PLATE WELDMENT, GEARBOX MOUNT		1
6	F05007-87	BOLT, 3/8-16 X 1" HEX HEAD GRADE 5		4
7	F05011-4	WASHER, 3/8" SPLIT LOCK		4
8	F05011-3	WASHER, 3/8" FLAT SAE		4
9	P21414	SPROCKET, 50BS10 X 1 MGR END		1
10	054451	GUARD WELDMENT, LOWER		1
11	F05005-134	BOLT, 1/4-20 X 3/4" HEX W/CONICAL WASHER HEAD		8
12	F05006-102	BOLT, 5/16-18 X 3/4" HEX HEAD		4
13	017832	KEY, 1/4" SQUARE X 1 3/8"		1
14	054448	COVER WELDMENT, TOP DRIVE		1
15	054455	PLATE, FRONT COVER		1
16	054484	CHAIN, #50 X 28 3/4"		1
17	P20208	LINK, #50 MASTER		1

6.3 Stationary Feed Rollers

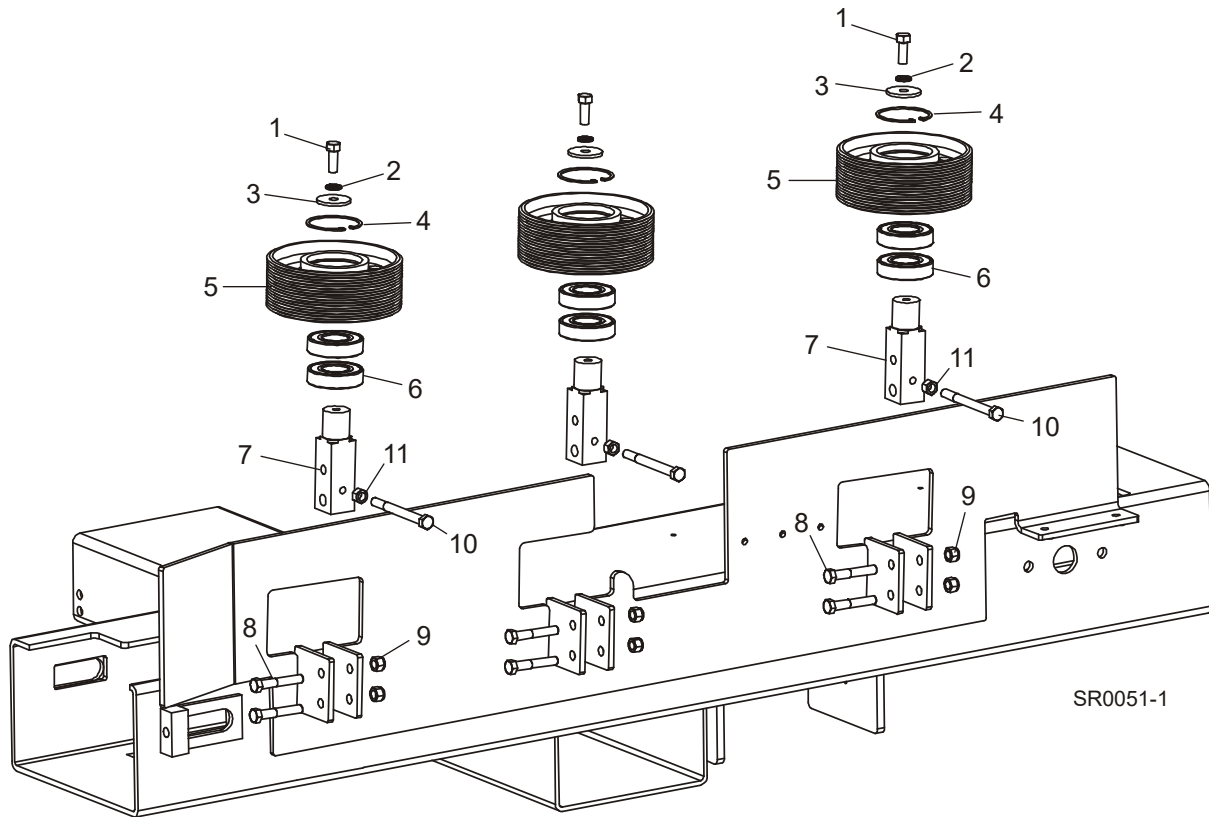

REF	PART #	DESCRIPTION	COMMENTS	QTY.
	054368	ROLLER ASSEMBLY, STATIONARY FEED		3
1	F05007-7	Bolt, 3/8-16 x 1" Hex Head		1
2	F05011-4	Washer, 3/8" Split Lock		1
3	F05011-104	Washer, 3/8" ID x 1 1/2" OD x 1/8" Thick		1
4	F04254-12	Ring, 62mm Interior Retaining		1
5	054369	Roller, Feed		1
6	P11035	Bearing, 6206-2NSE		2
7	054370	Shaft, Stationary Roller		1
8	F05007-201	BOLT, 3/8-16 X 2-1/4 HEX HEAD GRADE 5		6
9	F05010-10	NUT, 3/8-16 HEX NYLON LOCK		6
10	F05007-92	BOLT, 3/8-16 X 4" HEX HEAD FULL THREAD G5		3
11	F05010-1	NUT, 3/8-16 HEX		3

6.4 Pressure Roller Assembly

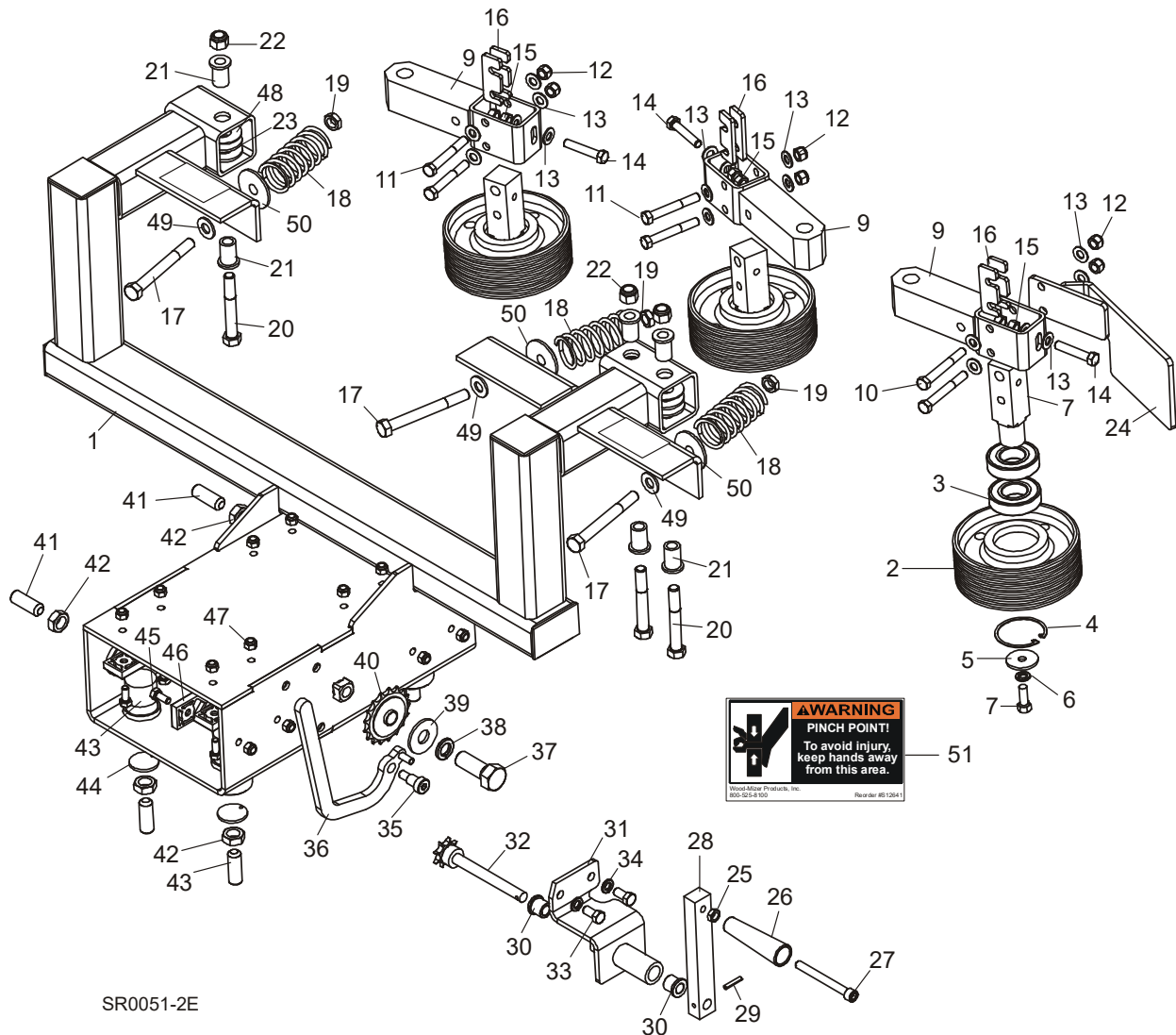

SR0051-2E

REF	PART #	DESCRIPTION	COMMENTS	QTY.
	054375	ROLLER ASSEMBLY, PRESSURE		1
1	054376	Frame Weldment, Pressure Roller		1
	054368	Roller Assembly, Stationary Feed		3
2	054369	Roller, Feed		1
3	P11035	Bearing, 6206-2NSE		2
4	F04254-12	Ring, 62mm Inside Retaining		1
5	F05011-104	Washer, 3/8" ID x 1 1/2" OD x 1/8" Thick		1
6	F05011-4	Washer, 3/8" Split Lock		1
7	F05007-7	Bolt, 3/8-16 x 1" Hex Head		1
8	054370	Shaft, Stationary Roller		1
9	054399	Block Weldment, Roller Mount		3
10	F05007-73	Bolt, 3/8-16 x 3" Hex Head Grade 5		2
11	F05007-206	Bolt, 3/8-16 x 2 3/4" Hex Head Grade 5		4
12	F05010-10	Nut, 3/8-16 Hex Nylon Lock		6
13	F05011-3	Washer, 3/8" Flat SAE		18

REF	PART #	DESCRIPTION	COMMENTS	QTY.
14	F05007-16	Bolt, 3/8-16 x 2" Hex Head Full Thread		3
15	F05010-1	Nut, 3/8-16 Hex		6
16	038583	Plate, Roller Shaft Spacer		6
17	F05008-35	Bolt, 1/2-13 x 4 1/2" Hex Head Grade 5		3
18	054462	Spring, 1-11/16" x 3-1/2" x .177" (MH100-300)		3
19	F05010-31	Nut, 1/2-13 Hex Jam		3
20	F05008-61	Bolt, 1/2-13 x 3 1/2" Hex Head Grade 5		3
21	054403	Bushing, 1/2" x 3/4" x 1-1/4"		6
22	F05010-8	Nut, 1/2-13 Hex Nylon Lock		3
23	054423	Spacer, 1" x 1-3/4" x 1/8"		6
24	054400	Shoe Weldment, Cant		1
	054417	Crank Assembly, Roller Feed		1
25	F05010-29	Nut, 3/8-16 Hex Jam		1
26	060170	Handle, 3/8" Bore Tapered Plastic		1
27	F05007-111	Bolt, 3/8-16 x 3 1/2" Socket Head		1
28	007346	Block, Press Roller Handle		1
29	F05012-11	Pin, 3/16" x 1" Roll		1
30	P22317	Bushing, 1/2" X 3/4" Bronze Flanged		2
31	054418	Feed Weldment, In/Out		1
32	054433	Shaft Weldment, Roller Feed		1
33	F05007-118	Bolt, 3/8-16 x 3/4" Hex Head Grade 5		2
34	F05011-4	Washer, 3/8" Split Lock		2
35	F05008-63	Screw, 3/8-16 1/2x1/2 Socket Shoulder		1
36	065695	Stop Assembly, Pressure Roller		1
37	F05009-41	Bolt, 5/8-11 x 1-1/2" Hex Head Full Thread Grade 5		1
38	F05011-27	Washer, 5/8" Split Lock		1
39	F05011-40	Washer, 5/8" Standard Flat		1
40	P04333	Sprocket, #40 Idler 17T 5/8" ID		1
41	F05009-27	Screw, 5/8-18 x 1 3/4" Flat Point Socket Set		6
42	F05010-11	Nut, 5/8-18 Hex Jam		6
43	033098	Pad, Round Nylon		6
44	042432	Pad, Nylon Backing		6
45	F05006-5	Bolt, 5/16-18 x 3/4" Hex Head Grade 2		11
46	M04096	Pads, Delrin Up/Down Slide		6
47	F05010-58	Nut, 5/16-18 Hex Nylon Lock		12
48	054467	Spacer, 3/4" ID x 1 3/4" OD x 1/16" Thick		3
49	F05011-101	Washer, 1/2" SAE Flat Grade 5		3
50	054457	Bushing, Spring		3
51	S12641	DECAL, HAND PINCH POINT WARNING		2

6.5 Pressure Roller Chain Assembly

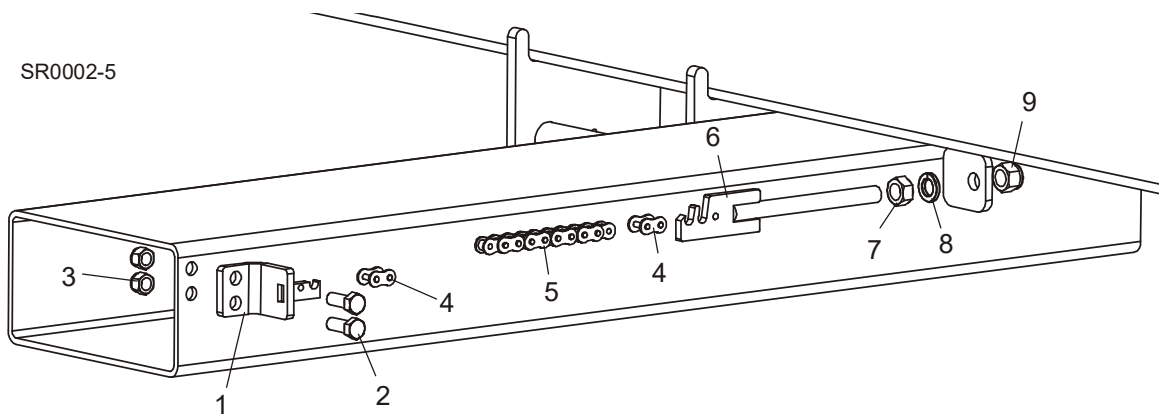

REF	PART #	DESCRIPTION	COMMENTS	QTY.
1	054414	PLATE WELDMENT, CHAIN MOUNT		1
2	F05007-87	BOLT, 3/8-16 X 1" HEX HEAD GRADE 5		2
3	F05010-10	NUT, 3/8-16 HEX NYLON LOCK		2
4	P04200	LINK, #40 MASTER		2
5	054465	CHAIN, #40 X 21-1/2"		1
6	015721	TENSIONER WELDMENT, POWER FEED CHAIN		1
7	F05010-35	NUT, 1/2-13 FREE HEX		1
8	F05011-9	WASHER, 1/2" SPLIT LOCK		1
9	F05010-8	NUT, 1/2-13 HEX NYLON LOCK		1

SECTION 7 FRAME

7.1 Saw Head Tilt Assembly

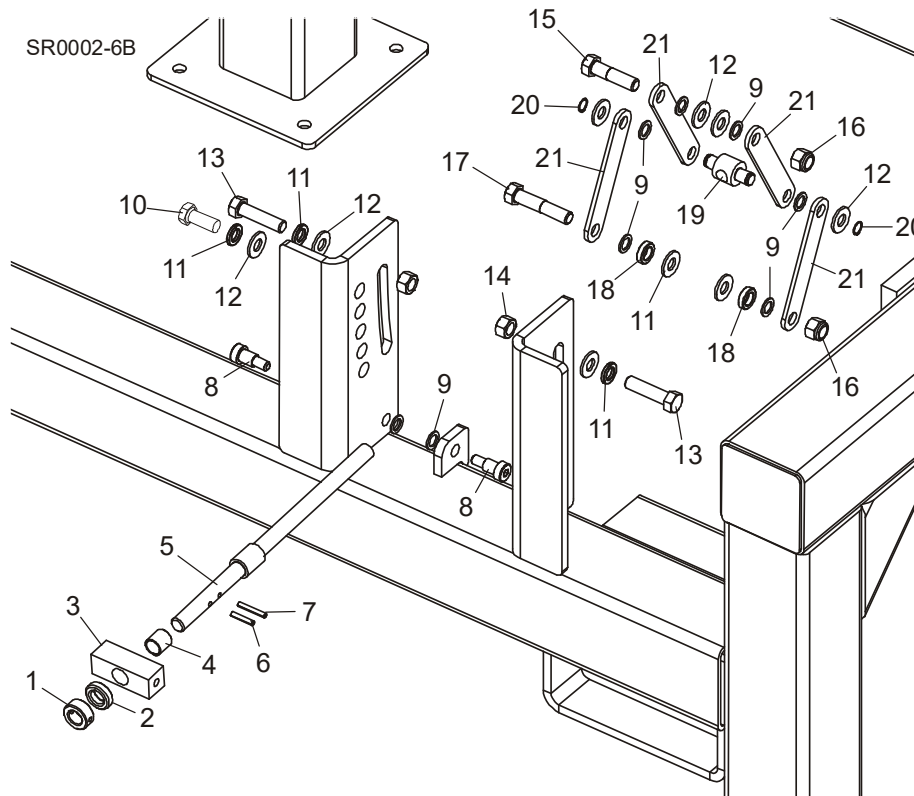

REF	PART #	DESCRIPTION	COMMENTS	QTY.
	130147	ASSY, HR300 SHR HEIGHT ADJUST	130147 replaced 038479 after 3/15/2022 per ECN 38431.	1
	038479	SHAFT ASSEMBLY, SHR TILT		1
1	130126	Collar, 5/8IDx1-1/4OD 51102 Brng	130126 replaced 016267, 130128 replaced P04214, and 130136 replaced 038477 after 3/15/2022 per ECN 38431.	1
	016267	Collar, 5/8" I.D. x 1 1/8" O.D. Lock 3/16" thru.		1
2	130128	Bearing, Thrust 51102 15mm x 28mm x 9mm	130126 replaced 016267, 130128 replaced P04214, and 130136 replaced 038477 after 3/15/2022 per ECN 38431.	1
	P04214	Bearing, 5/8" Thrust		1
3	038470	Pivot, SHR Tilt		1
4	P09130	Spacer, 5/8" I.D. x 3/4" O.D. x 3/4" Long Bronze		1
5	130136	Wldmt, SHR Tilt Adjust Shaft	130126 replaced 016267, 130128 replaced P04214, and 130136 replaced 038477 after 3/15/2022 per ECN 38431.	1
	038477	Shaft Weldment, SHR Tilt Adjustment		1
6	F05012-11	Pin, 3/16" x 1" Roll		1
7	F05012-16	Pin, 3/16" x 1 1/4" Roll		1
8	F05008-115	BOLT, 3/8-16 1/2 X 5/8" THREADED SHOULDER		2
9	P05251-1	WASHER, 1/2" X 3/4" X 1/16" NYLON		8

7 Replacement Parts
Saw Head Tilt Assembly

REF	PART #	DESCRIPTION	COMMENTS	QTY.
10	F05008-37	BOLT, 1/2-13 X 1 1/4" HEX HEAD GRADE 5		1
11	F05011-9	WASHER, 1/2" SPLIT LOCK		3
12	F05011-2	WASHER, 1/2" SAE FLAT		9
13	F05008-116	BOLT, 1/2-13 X 2" HEX HEAD FULL THREAD GRADE 5		2
14	F05010-3	NUT, 1/2-13 SWAGED HEX 2-WAY LOCK		2
15	F05008-102	BOLT, 1/2-13 X 2" HEX HEAD GRADE 5		1
16	F05010-8	NUT, 1/2-13 HEX NYLON LOCK		2
17	F05008-74	BOLT, 1/2-13 X 2 1/2" HEX HEAD GRADE 5		1
18	041626	SPACER, 1/2" I.D. X 7/8" O.D. X 1/4"		2
19	038475	TRUNION, SHR TILT		1
20	F04254-18	RING, SHAFT 1/2" OR 3100-50 RETAINING		2
21	038474	LINK, SHR TILT ADJUSTMENT		4

7.2 Control Box & Harnesses

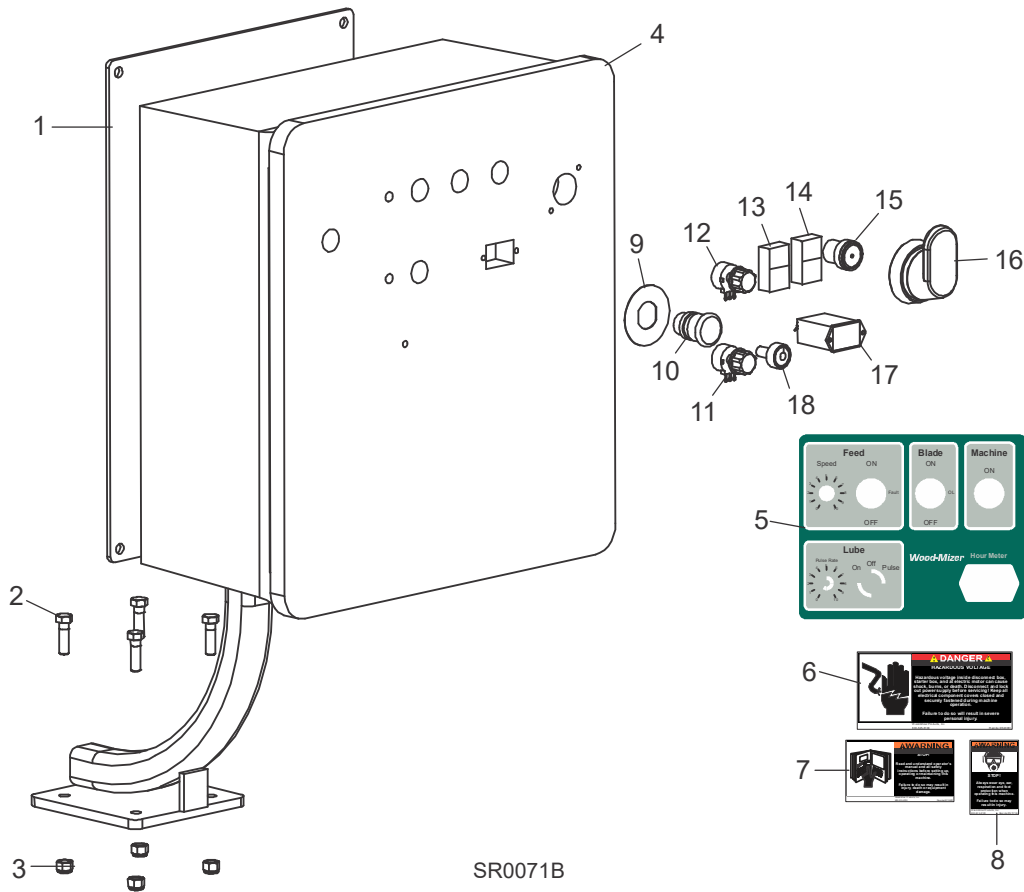

SR0071B

REF	PART #	DESCRIPTION	COMMENTS	QTY.
1	054427	POST WELDMENT, CONTROL		1
2	F05007-123	BOLT, 3/8-16 X 1 1/4" HEX HEAD GRADE 5		4
3	F05010-10	NUT, 3/8-16 HEX NYLON LOCK		4
	052480	CONTROL BOX ASSEMBLY, HR300 230V 1PH 10HP (NOT SHOWN)		1
	052476	CONTROL BOX ASSEMBLY, HR300 460V 3PH 20HP (NOT SHOWN)		1
	052772	CONTROL BOX ASSEMBLY, HR300 380V 3PH 20HP (NOT SHOWN)		1
	052478	CONTROL BOX ASSEMBLY, HR300 230V 3PH 20HP (NOT SHOWN)		1
	052472	CONTROL BOX ASSEMBLY, HR300 460V 3PH 25HP (NOT SHOWN)		1
	052474	CONTROL BOX ASSEMBLY, HR300 230V 3PH 25HP (NOT SHOWN)		1
4	052494	Enclosure, Control Box		1
	052471	Insert Assembly, HR300 460V 3Ph 25HP		1
	052473	Insert Assembly, HR300 230V 3Ph 25HP		1
	052475	Insert Assembly, HR300 460V 3Ph 20HP		1
	052771	Insert Assembly, HR300 380V 3Ph 20HP		1
	052477	Insert Assembly, HR300 230V 3Ph 20HP		1
	052479	Insert Assembly, HR300 230V 1Ph 10HP		1

7 Replacement Parts

Control Box & Harnesses

REF	PART #	DESCRIPTION	COMMENTS	QTY.
	052486-1	Harness Assembly, Feed Motor		1
	052488	Harness Assembly, Brake		1
	052492	Harness Assembly, Blade Motor (380/460V 3-Phase Only)		1
	052520	Harness Assembly, Blade Motor (230V 3-Phase Only)		1
	052523	Harness Assembly, Blade Motor (230V 1-Phase Only)		1
5	052444	Decal, Control Box		1
6	S20061	Decal, Electrical Hazard Danger		1
7	016402	Decal, Read Manual Warning		1
8	S11753	Decal, Eye/Ear Protection Warning		1
9	050992	Legend, E-Stop Round Yellow		1
10	052497	Switch, E-Stop Complete Push-Pull XB5		1
	050540	Contact, NC ZBE102		1
11	024590	Potentiometer Assembly, Lube-Mizer Control (LMS Option Only)		1
12	052451	Potentiometer Assembly, 1K SHR Feed Control		1
13	052499	Switch, 2 PBw/Pilot Green Flush Red Extend		1
	052498	Switch Body, 22mm Red LED 1NO 1NC 24V XB5		1
14	052499	Switch, 2 PBw/Pilot Green Flush Red Extend		1
	052498	Switch Body, 22mm Red LED 1NO 1NC 24V XB5		1
	050540	Contact, NC ZBE102		2
15	052503	Switch, PB Green Flush Illum ZB5		1
	052502	Switch Body, 22mm Grn LED 1NO 24V XB5		1
16	050906-1	Disconnect, 100Amp 3P Non-Fused 6mm		1
	050907-1	Operator, Red/Yellow Pistol Grip 6mm		1
	050908-1	Shaft, Pistol Grip Disconnect 290mm x 6mm		1
17	015401	Hour Meter, 12 Volt DC		1
18	114063	Switch Body, 22mm Clear LED 2NO 24V		1
	052613	Switch Head, 22mm Illum Green Selector (LMS Option Only)		1
		See Electrical Information Section in Operator's Manual for a complete list of electrical components		

SECTION 8 OPTIONS

8.1 End Table (Optional)

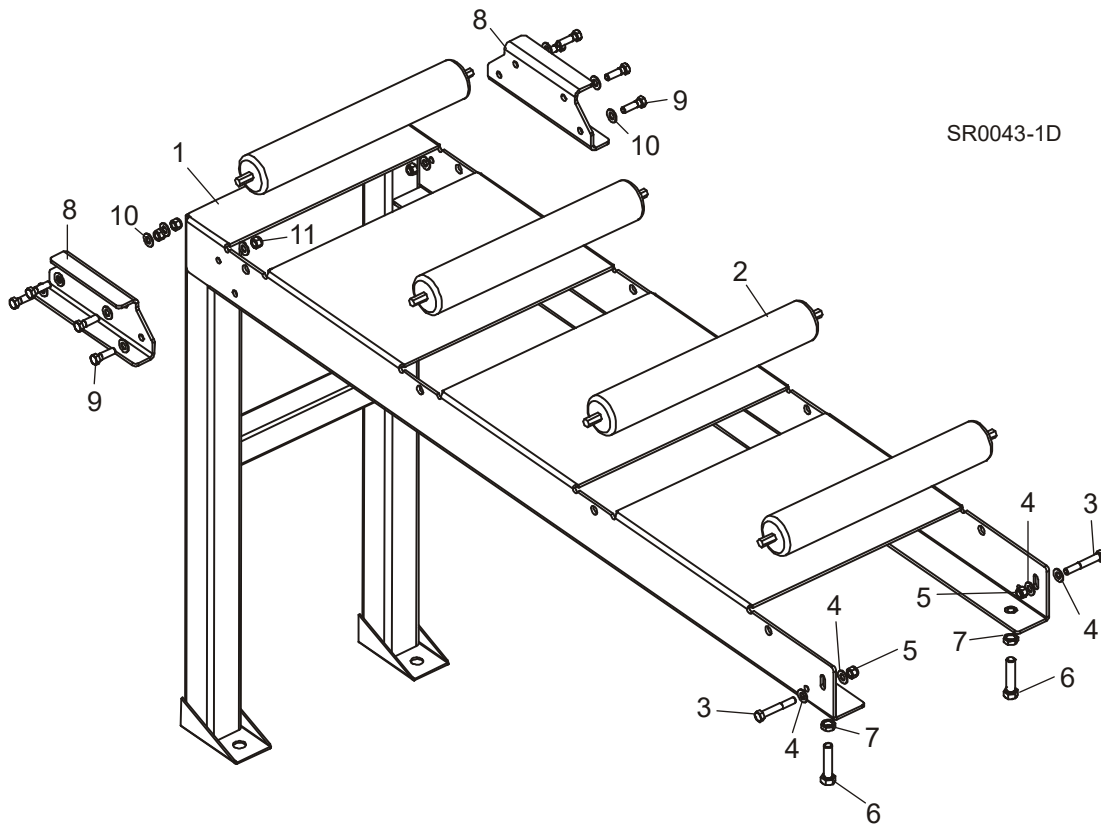

REF	PART #	DESCRIPTION	COMMENTS	QTY.
	054404	TABLE ASSEMBLY, END		2
1	054405	Table Weldment, End		1
2	054412	Roller, 2.5" OD x 16"		4
3	F05007-47	Bolt, 3/8-16 X 2 1/2" Hex Head Grade 2		2
4	F05011-3	Washer, 3/8" Flat SAE		4
5	F05010-10	Nut, 3/8-16 Hex Nylon Lock		2
6	F05008-27	Bolt, 1/2-13 X 2 1/4" Hex Head Full Thread		2
7	F05010-31	Nut, 1/2-13 Hex Jam		2
	003622	CONNECTOR KIT, SHR TABLE		1
8	003621	Plate, SHR Table Connector		2
9	F05007-123	Bolt, 3/8-16 x 1 1/4" Hex Head Grade 5		8
10	F05011-3	Washer, 3/8" SAE Flat		16
11	F05010-10	Nut, 3/8-16 Hex Nylon Lock		8

8.2 Feed Tables (Optional)

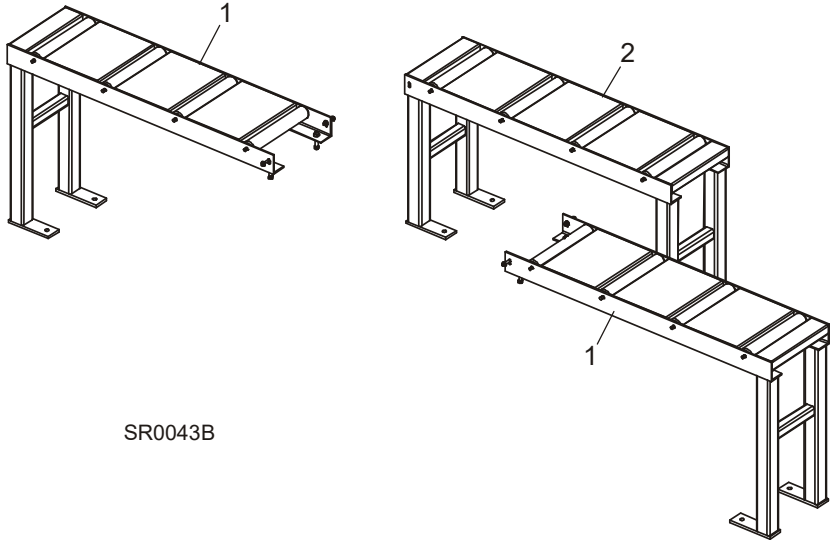

REF	PART #	DESCRIPTION	COMMENTS	QTY.
	054464	TABLE ASSEMBLY, OPTIONAL FEED		1
1		End Table Parts (See Section 8.1)		
2		Side Table Parts (See Section 8.3)		

8.3 Side Table (Optional)

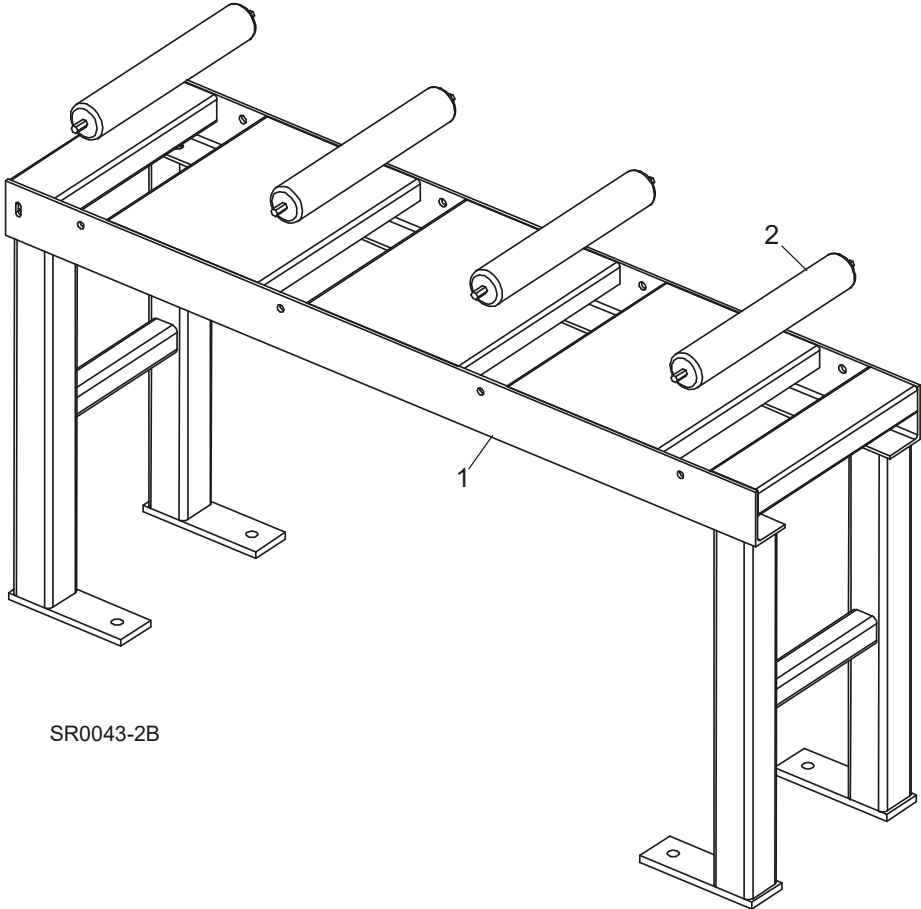

SR0043-2B

REF	PART #	DESCRIPTION	COMMENTS	QTY.
	054442	TABLE ASSEMBLY, SIDE		1
1	054443	Table Weldment, Side		1
2	054412	Roller, 2.5 OD x16		4

8.4 Lube-Mizer Pump Assembly (Optional)

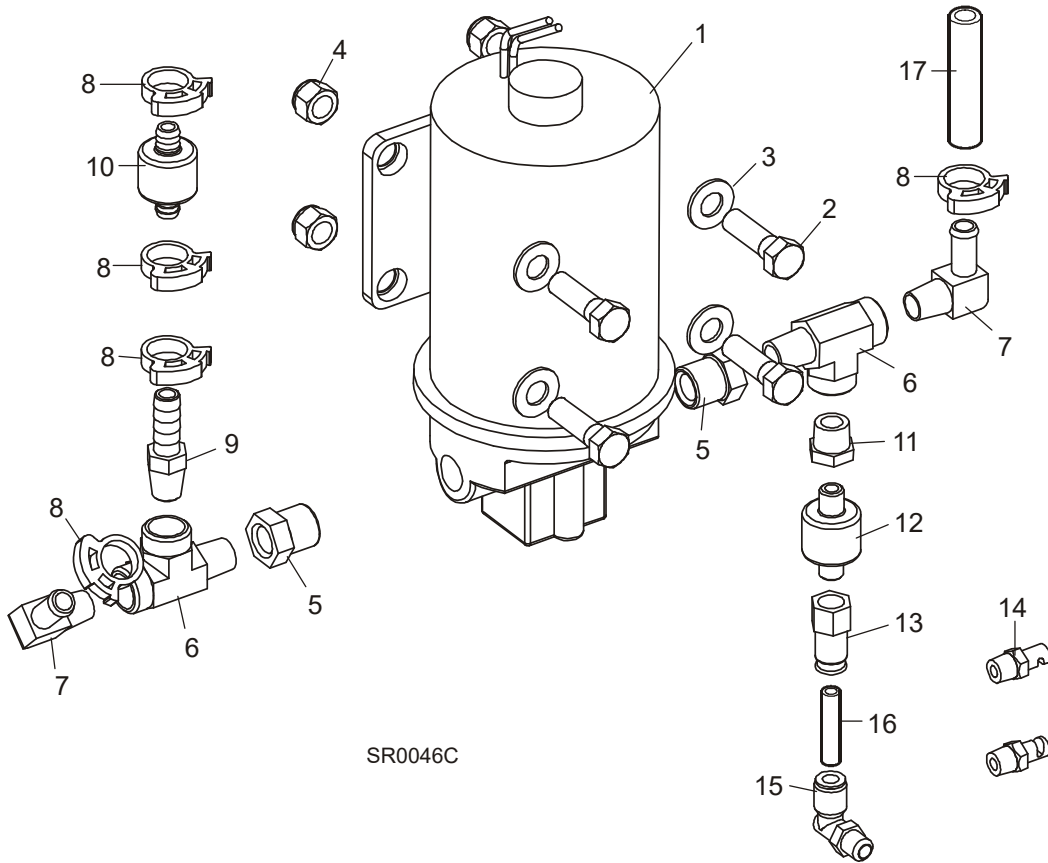

REF	PART #	DESCRIPTION	COMMENTS	QTY.
	ADD-1	LUBE ADDITIVE, CASE 4 60 OZ. BOTTLES		1
	LMS-SHR	LUBE-MIZER OPTION, FIELD-INSTALLED SHR		1
	038563	Pump Assembly, SHR LubeMizer		1
1	050029	Pump Assembly, Lube		1
2	F05007-123	Bolt, 3/8-16 x 1 1/4" Hex Head Grade 5		4
3	F05011-3	Washer, 3/8" Flat SAE		8
4	F05010-10	Nut, 3/8-16 Hex Nylon Lock		4
5	015490	Fitting, 3/8" NPT-1/4" NPT Reducer		2
6	P09141	Fitting, 1/4" NPT x 1/4" JIC Male Run Tee		2
7	016330	Fitting, 1/4" NPT x 3/8" Hose Barb, Elbow		2
8	016845	Clamp, Single Snap Grip #38		5
9	014685	Fitting, 1/4" NPT-3/8" Barb		1
10	033448	Valve, 3/8" Barb 6PSI Check		1
11	P22680	Reducer, 1/4" NPT - 1/8" NPT		1
12	033449	Valve, 1/8" NPT 3PSI Check		1
13	033450	Fitting, 1/4" TB x 1/8" NPT Male Air		1
14	033479	Fitting, Blade Lube Spray		2
15	P09736	Fitting, 1/4" MPT x 1/4" Tube Swivel Elbow		1
16	R01869	Tubing, 1/4" Air		2 ft.
17	R01885-1	Tubing, 3/8" ID Flex PVC Braided		2.75 ft.
	052615	Control Assembly, SHR LubeMizer		1

B

blade drive 1

blade guides

drive side 4

idle side 1

blade motor (10HP) 7

blade motor (20HP/25HP) 5

C

control box & harnesses 1

covers & sawdust chute 1

D

drive belt covers and brake solenoid 3

E

end table (optional) 1

F

feed motor assembly 1

feed tables (optional) 1

feed track 1

I

idle blade wheel 8

L

laser guides housing 1

lubemizer pump 1

M

mast assembly 1

middle throat screw 2

P

pressure roller assembly 1

pressure roller chain 1

S

saw head decals 1

saw head tilt assembly 1

side table (optional) 1

stationary feed rollers 1

U

up/down system 1

W

water lube 3