

Wood-Mizer[®] Toothsetter

Safety, Operation, Parts & Maintenance Manual

TSG

Rev. A.00 - J.00



Safety is our #1 concern! Read and understand all safety information and instructions before operating, setting up or maintaining this machine.

April 1997

Form #224

Table of Contents

Section-Page

SECTION 1	OVERVIEW	1-1
1.1	Toothsetter/Gauge Introduction.....	1-1
1.2	Deburring The Blade	1-2
SECTION 2	SETUP	2-1
2.1	Toothsetter Mount	2-1
2.2	Blade Support Installation	2-2
2.3	Dial Indicator Setup.....	2-3
	<i>TSG Toothsetter Rev. A - D</i>	
	<i>TSG Toothsetter Rev. E+</i>	
SECTION 3	OPERATION	3-1
3.1	Blade Installation.....	3-1
3.2	Toothsetter Adjustments.....	3-3
3.3	Toothsetter Operation.....	3-5
SECTION 4	REPLACEMENT PARTS	4-1
4.1	How To Use The Parts List	4-1
4.2	Sample Assembly	4-1
4.3	Toothsetter Parts.....	4-2
	<i>TSG Rev. E+</i>	
4.4	Toothsetter Parts.....	4-5
	<i>TSG Rev. D</i>	
4.5	Stand Assembly	4-8
	<i>TSG Retrofit</i>	
SECTION 5	MAINTENANCE	5-1
5.1	Toothsetter Maintenance	5-1
	INDEX	I

SECTION 1 OVERVIEW

1.1 Toothsetter/Gauge Introduction

There are four steps to maintaining blades used on the Wood-Mizer sawmill. They should ALWAYS be followed in this order:

1. Blade Cleaning
2. Sharpening
3. Deburring
4. Toothsetting

See Figure 1-1. The blades supplied by Wood-Mizer have a raker-style set in the teeth. If you look at a blade from the top, you will see that the teeth are set (or bent out) in a repeating sequence; straight, left and right. The teeth that are set left and right do the cutting. The straight teeth (rakers) clear the cut of sawdust.

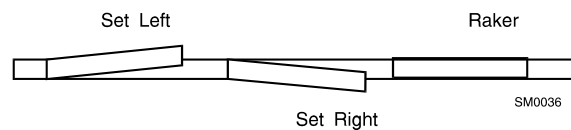

FIG. 1-1

See Figure 1-2. As the blade is sharpened, the tip of the tooth recedes and the set becomes smaller. Correct setting is one of the most important factors in the cutting ability of a blade. Check used blades regularly to see if they need resetting.

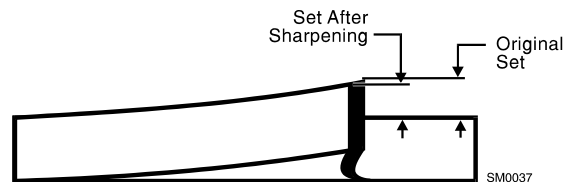

FIG. 1-2

The Toothsetter/Gauge (TSG) provided in the Blade Maintenance Package allows you to accurately and evenly set the teeth of a bandsaw blade. The spring-loaded clamping mechanism lets you position a tooth in front of the Gauge and clamp it in place. You can then measure the set. The tooth is bent by clamping the blade further. This chapter describes proper setup and operation of the toothsetter.

1.2 Deburring The Blade

Sharpening leaves tiny metal burrs on the back side of the teeth. New blades also have burrs. These burrs **MUST** be removed before the set is checked. If they are not removed, they may cause the toothsetter to give false readings.

To remove burrs, take the blade from the Sharpener. Invert it, so that the inside of the blade is facing out. Drag a stick of hardwood across the blade in the opposite direction that the teeth cut. (Use the weld in the blade as a reference point for starting and stopping.)

Cutting with the blade also removes burrs. If the blade you are about to set has been used after sharpening, you will not need to deburr it. Clean the blade before removing from the mill by running the Water Lube Option for 15 seconds. Remove the blade and wipe dry with a rag to prevent rusting.

SECTION 2 SETUP

2.1 Toothsetter Mount

Mount the toothsetter to the stand. Use the mounting holes found in the base plate of the setting fixture. Use the provided bolts (inserting the bolts down through the top of the mounting plate), hex nuts and washers. Setup the toothsetter so that there is at least 32" (81.0 cm) to the rear and to either side of the tool. This allows enough room for the blade supports.

See Figure 2-1. The main components of the toothsetter are shown below. These parts will be discussed in the following instructions.

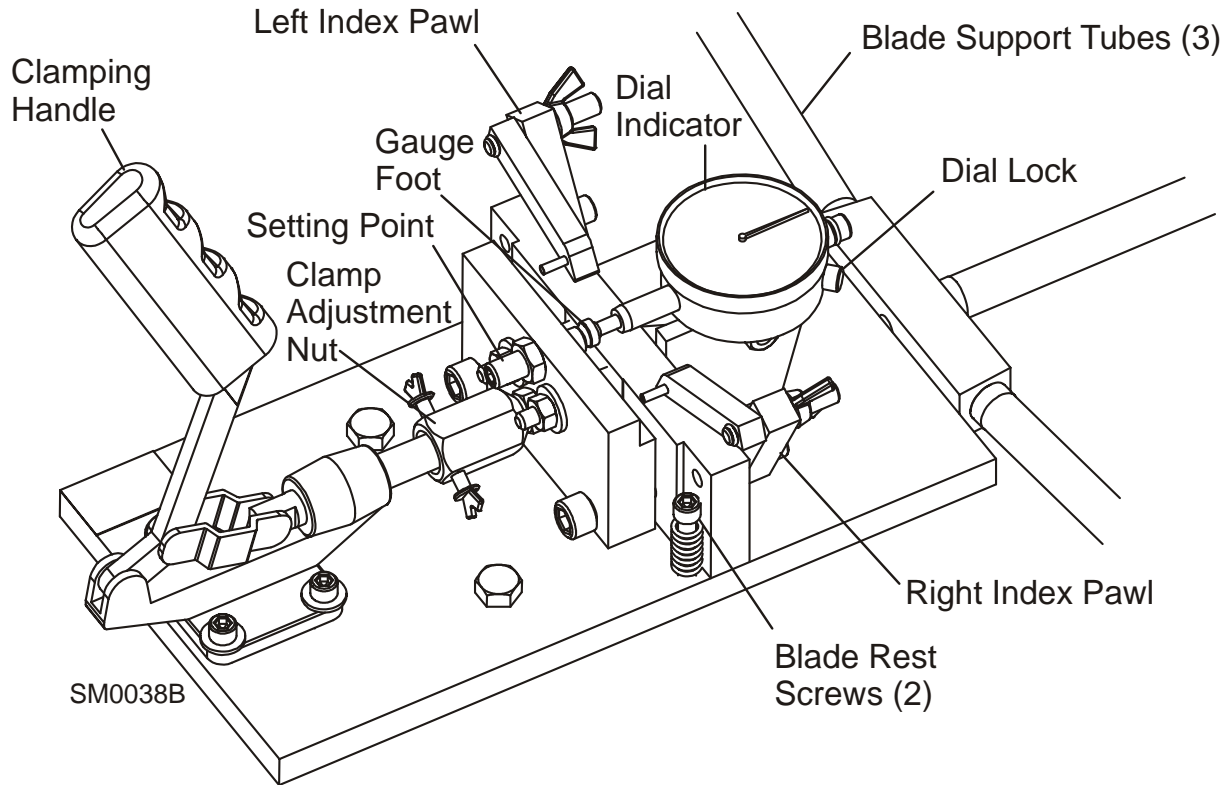

FIG. 2-1

2.2 Blade Support Installation

Attach the three blade support arms to the threaded mounting bar at the rear of the tooth-setter.

See Figure 2-2. Assemble a blade support guide onto the end of each blade support arm. Bolt from the hexed side of the guide assembly. Tighten the top bolts with the self-locking nuts. Tighten the bottom bolts with the wing nuts.

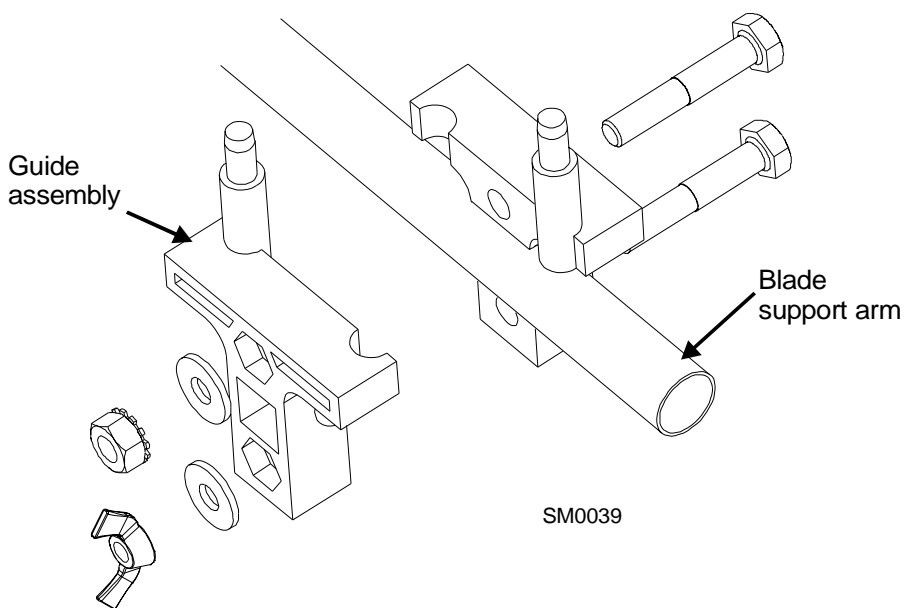

FIG. 2-2

The guides should be about 1" (2.5 cm) from the ends of the right and rear tubes and about 2.5" (6.0 cm) from the end of the left tube. Final adjustments will be made later.

2.3 Dial Indicator Setup

TSG Toothsetter Rev. A - D

To set the dial indicator, follow these steps.

See Figure 2-3.

1. **Back the setting point out of the way.** Insert the hex key in the end of the setting contact point shaft and turn counterclockwise until the setting contact point is behind the front edge of the moving clamping plate.
2. **Adjust the Dial Indicator.** Clamp the gauge bar between the clamping plates. The gauge ball should be touching the center of the gauge foot.

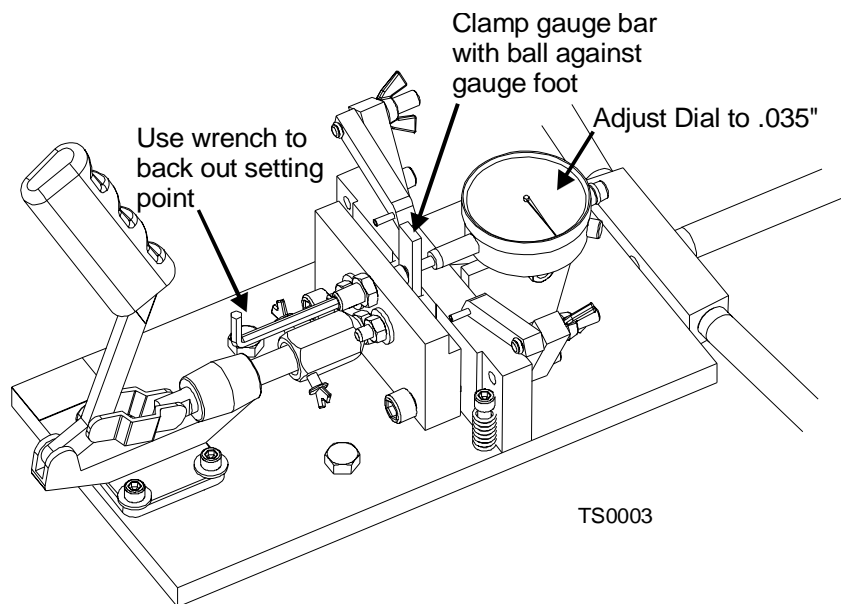

FIG. 2-3

The dial indicator should read .035. If the dial indicator does not show .035, loosen the dial lock on the upper right side of the dial indicator. Rotate the dial indicator to .035 and retighten the dial lock.

Now, remove the gauge bar from the toothsetter clamp. The dial indicator should now read zero ($\pm.003$).

See **Figure 2-4**. If the dial indicator reads more than .003 or less than -.003 with nothing clamped, you will need to adjust the indicator mounting block:

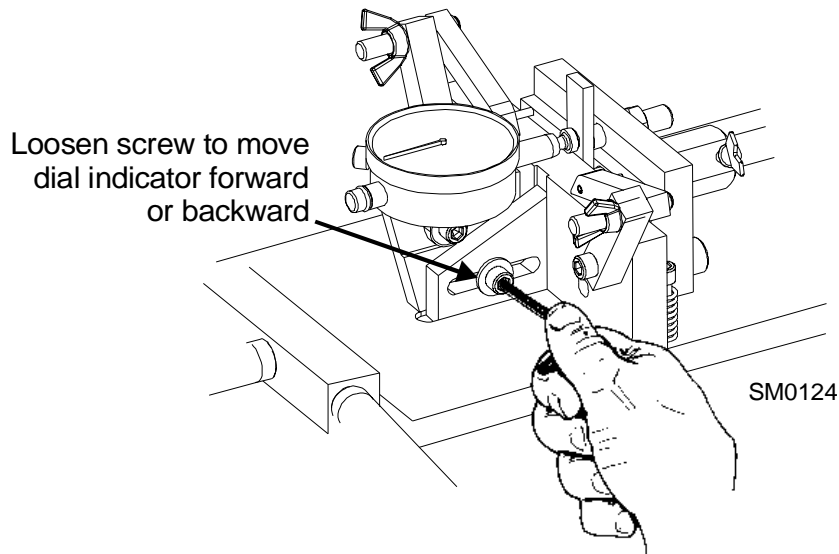

FIG. 2-4

1. Loosen the dial lock and adjust the dial face until it reads zero with nothing touching the gauge foot.
2. Reclamp the gauge bar with the ball centered on the gauge foot.
3. Loosen the screw at the bottom of the indicator mounting block. Move the indicator assembly until the gauge reads .035 (± 0.003). Retighten the mounting block screw. Make sure the mounting block remains flat against the toothsetter base plate.
4. Unclamp the gauge bar. The indicator should now read zero (± 0.003). If not, repeat steps 1 - 4.

TSG Toothsetter

Rev. E+

To set the dial indicator, follow these steps.

See **Figure 2-5**.

1. **Back the setting point out of the way.** Insert the hex key in the end of the setting contact point shaft and turn counterclockwise until the setting contact point is behind the front edge of the moving clamping plate.
2. **Adjust the Dial Indicator.** Clamp the gauge pin between the clamping plates. The pin

should be touching the center of the gauge foot.

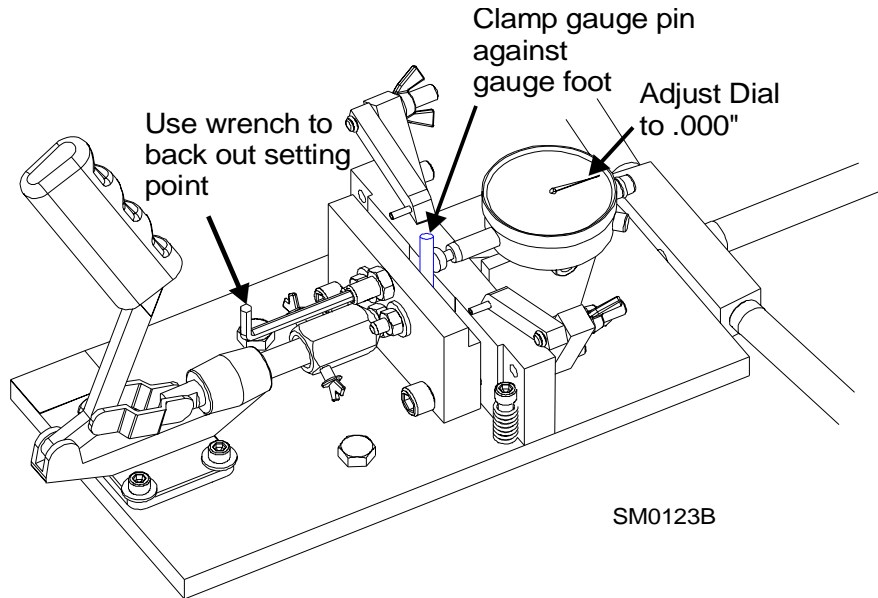

FIG. 2-5

The dial indicator should read 0. If the dial indicator does not show 0, loosen the dial lock on the upper right side of the dial indicator. Rotate the dial indicator to 0 and retighten the dial lock.

Now, remove the gauge pin from the toothsetter clamp. The dial indicator should now read between -.001 and -.005.

See **Figure 2-6**. If the dial indicator does not read between $-.001$ and $-.005$ with nothing clamped, you will need to adjust the indicator position:

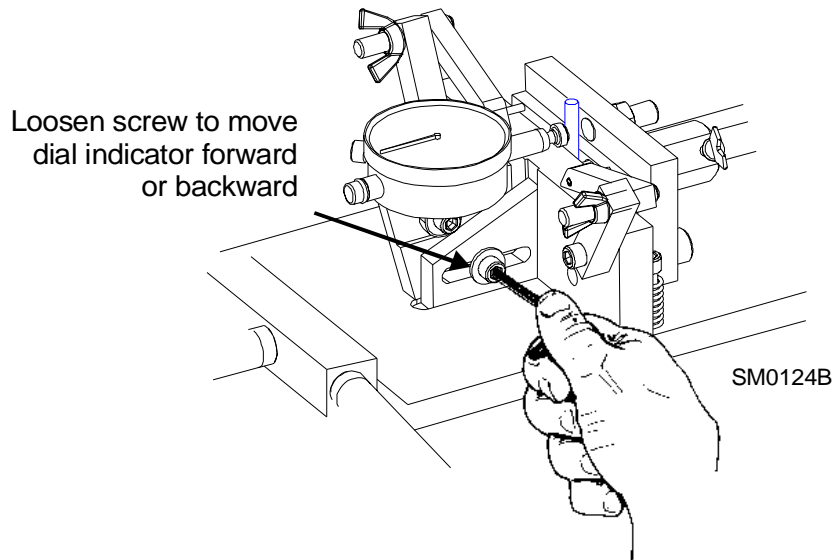

FIG. 2-6

3. Reclamp the gauge pin centered on the gauge foot.
4. Loosen the screw at the bottom of the indicator mounting block. Move the indicator assembly back until the gauge foot does not touch the gauge pin.
5. Move the indicator assembly forward so the gauge foot touches the gauge pin and the gauge needle moves $.001 - .005$. Retighten the mounting block screw. Make sure the mounting block remains flat against the toothsetter base plate.
6. Rotate the dial face until the gauge reads zero.
7. Unclamp the gauge pin. The indicator should now read $-.001$ to $-.005$. If not, repeat steps 3 - 6.

SECTION 3 OPERATION

Once the toothsetter alignments have been checked and adjustments have been made, you are ready to measure and set blades.

Sharpening removes metal from the face of the tooth. This eventually reduces the set to a point where the blade will not cut very well. Set should not vary more than $(\pm)0.001$ from one tooth to the next and $(\pm)0.001$ from one side of the blade to the other side.

The following steps will take you through operation of the toothsetter.

Note: Refer to the [Wood-Mizer® Blade Handbook](#) for recommended set specifications for your sawing application.

3.1 Blade Installation

1. **Clean the blade and deburr before putting it in the toothsetter.** Otherwise, sap buildup on the blade or tooth will give false set readings. Metal burrs created by sharpening also will cause false readings.
2. **Mount the blade in the toothsetter.** Place blade between the clamping plates and on the three guide assemblies.

NOTE: You will need to move both the left and right index pawl assemblies down and out of the way. These will be adjusted later.

3. **Set the clamping assembly to hold the blade.** The clamp is set at the factory to lock the blade firmly as the handle throws over. If the handle is difficult to push forward or throws over before locking the blade, adjust the clamp nut.

3 Operation

Blade Installation

See Figure 3-1. Loosen the thumb screws and turn the clamp nut clockwise to tighten the clamp or counterclockwise to loosen the clamp. After the clamp is adjusted properly, tighten the thumb screws.

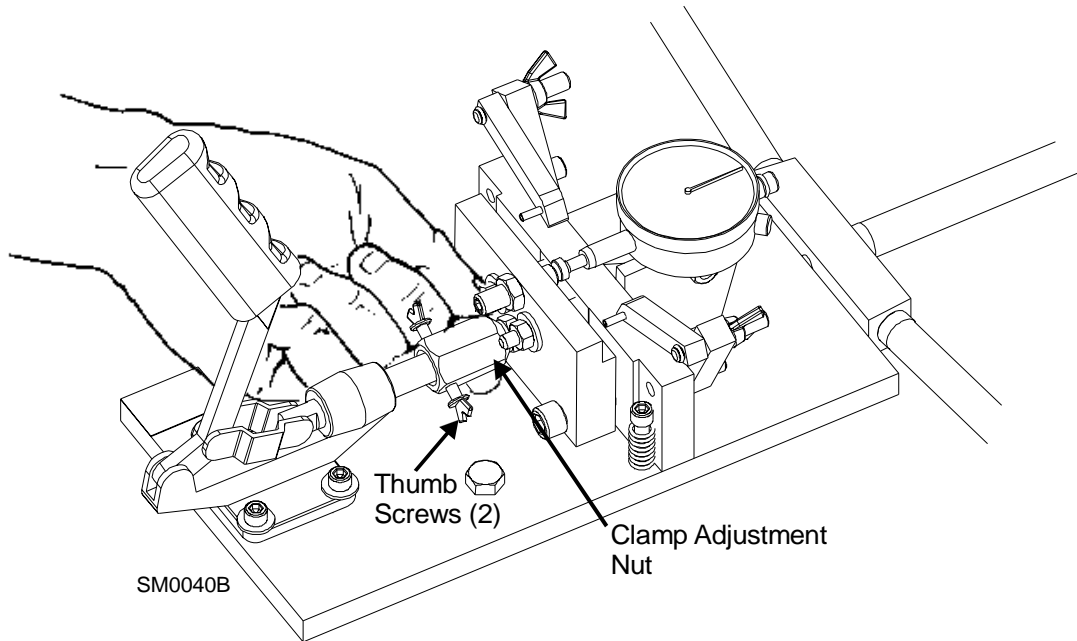

FIG. 3-1

3.2 Toothsetter Adjustments

See Figure 3-2.

1. **Adjust the blade rest screws.** Rest the blade evenly on the two blade rest screws on each side of the clamp. Adjust the rest screws until the gullet of the blade lies just above the top of the clamp plates. (Deburring will remove burrs from the back side of the teeth, but may not remove burrs from the gullet area. Keeping the gullet out of the clamp assembly helps to assure accurate readings.)

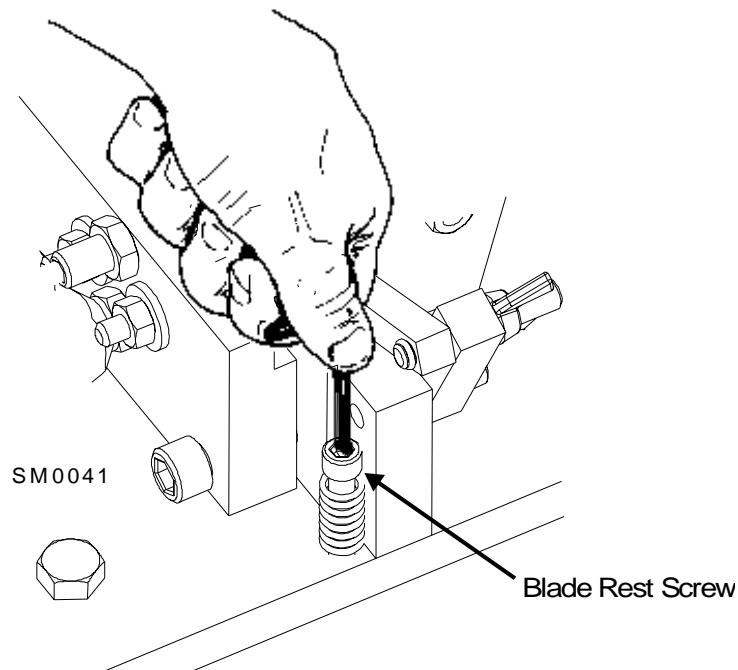

FIG. 3-2

2. **Make final adjustments to blade support arms and guide assemblies.** Adjust to assure the blade travels smoothly. Blade should rest on rear guide, but should not touch the bottom of either side guide assembly.
3. **Adjust the setting contact point.** Position the blade so the gauge foot is in between two teeth. Use the hex key to bring the setting contact point towards the gauge foot until the dial indicator reads 15-20 thousandths.

3

Operation

Toothsetter Adjustments

- 4. Position the blade.** Turn the blade to bring a weld into the clamping/setting assembly. Use the weld as a reference point for starting and stopping. Start with the first tooth to the right (See NOTE) of the weld that has been set back toward the dial indicator.

NOTE: The toothsetter sets and measures the teeth which are set away from the operator and towards the dial indicator. To measure teeth set in the opposite direction, invert the blade and insert it in the toothsetter.

See Figure 3-3. Position that tooth in front of the gauge foot so the its edge is aligned with the center of the setting point.

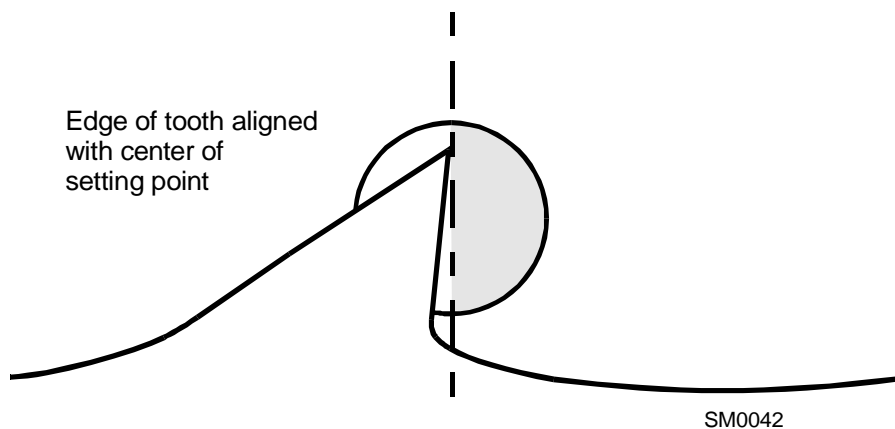

FIG. 3-3

- 5. The index pawls are factory-set for Wood-Mizer® Industrial blades with 7/8" tooth spacing.** Check the right (or left if the blade is inverted) side index pawl is firmly against the tooth two teeth to the right (or left) of the one being set. To adjust, loosen the index pawl screw with the hex key provided and move the pawl tight against the tooth. Retighten the screw.

3.3 Toothsetter Operation

NOTE: These instructions assume you are setting the blade starting with the blade not inverted. Set the first side of the blade using the right index pawl. After setting the first side of the blade, invert the blade and use the left index pawl when setting the other side of the blade.

1. **Set the blade.** Measure set by clamping the blade between the back clamping plate and the spring-loaded pins on the front clamping plate. Remember set should not vary more than $(\pm)0.001$ from one tooth to the next.

To add set, clamp in further on the blade. This brings the setting contact point against the tooth. The amount you will need to bend the tooth forward to get the desired set will vary. Recheck set and adjust as needed.

NOTE: If the clamp locks before you have added enough set, adjust the setting contact point in. **DO NOT** adjust the clamp nut.

To decrease set, bend the tooth back with the slot in the correction tool provided. Recheck set and adjust as needed.

Slide the blade to the right until the third tooth from the one just set comes in front of the gauge foot. Push this tooth firmly against the index pawl. Check set by lightly pushing the handle until the spring-loaded pins in the clamping assembly push the blade against the back plate. Read the dial indicator. Adjust set as necessary (see above). Check every third tooth until you reach the weld.

2. **Set the opposite side of blade.** Remove the blade and invert it. Put the blade back in the toothsetter with the teeth pointing to the left. Repeat the above steps to set the teeth using the left side index pawl assembly. The amount that you must bend the teeth to end up with the same set as the first side of the blade probably will differ.
3. **Remove the blade.** Take the blade out of the toothsetter. Be sure the blade is turned to the correct side before putting it on the sawmill.

SECTION 4 REPLACEMENT PARTS

4.1 How To Use The Parts List

- Use the index above to locate the assembly that contains the part you need.
- Go to the appropriate section and locate the part in the illustration.
- Use the number pointing to the part to locate the correct part number and description in the table.
- Parts shown indented under another part are included with that part.
- Parts marked with a diamond (◆) are only available in the assembly listed above the part.

See the sample table below. Sample Part #A01111 includes part F02222-2 and subassembly A03333. Subassembly A03333 includes part S04444-4 and subassembly K05555. The diamond (◆) indicates that S04444-4 is not available except in subassembly A03333. Subassembly K05555 includes parts M06666 and F07777-77. The diamond (◆) indicates M06666 is not available except in subassembly K05555.

4.2 Sample Assembly				
REF	DESCRIPTION (◆ Indicates Parts Available In Assemblies Only)	PART #	QTY.	
	Sample Assembly, Complete (Includes All Indented Parts Below)	A01111	1	
1	Sample Part	F02222-22	1	
	Sample Subassembly (Includes All Indented Parts Below)	A03333	1	
2	Sample Part (◆ Indicates Part Is Only Available With A03333)	S04444-4	1	◆
	Sample Subassembly (Includes All Indented Parts Below)	K05555	1	
3	Sample Part (◆ Indicates Part Is Only Available With K05555)	M06666	2	◆
4	Sample Part	F07777-77	1	

To Order Parts:

- From the continental U.S., call **1-800-525-8100** to order parts. Have your customer number, serial number, and part numbers ready when you call.
- From other international locations, contact the Wood-Mizer distributor in your area for parts.

4.3 Toothsetter Parts

TSG

Rev. E+

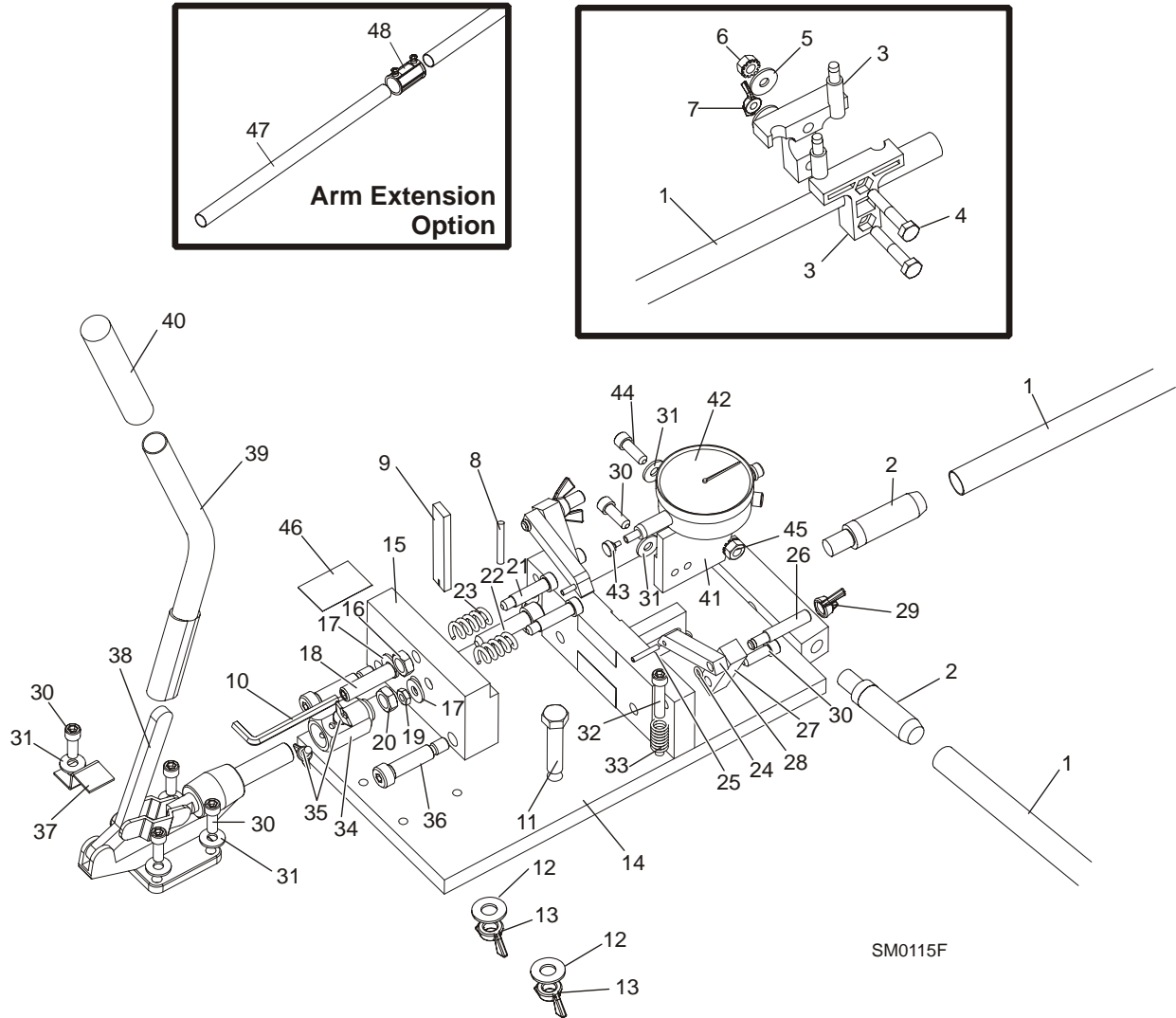

REF	DESCRIPTION (◆ Indicates Parts Available In Assemblies Only)	PART NUMBER	QTY.	
	TOOTHSETTER/GAUGE ASSY, COMPLETE WITH BLADE SUPPORT ARMS	LTTSG ¹	1	◆
	Arm Assembly, Blade Support	A04545	1	
	Tube Assembly, Blade Support	A04550	3	
1	Tube, Blade Support	M04551	1	◆
2	Plug, Tube Support	P04552	1	
	Blade Support Support Assembly, Replacement	A10617	1	
	Bag Assembly, Blade Support	A10615	1	
3	Guide W/Post, Blade Support	S10611	6	
4	Bolt, 1/4-20 X 1 1/2" Hex Head Grade 2	F05005-5	6	

4

Replacement Parts

Toothsetter Parts

5	Washer, 1/4" SAE Flat	F05011-11	6	
6	Nut, 1/4-20 Self-Locking	F05010-9	3	
7	Nut, 1/4-20 Wing	F05010-13	3	
	Toothsetter Assembly, Boxed	A04740 ¹	1	◆
	Toothsetter Assembly	A04709	1	◆
8	Pin, Toothsetter Alignment	F05012-60	1	
9	Tool, Set Correction	004754	1	
10	Key, 3/16" Hex	P06147	1	
11	Bolt, 3.8-16 x 1 3/4" Hex Head	F05007-19	2	
12	Washer, 3/8" Flat	F05011-3	2	
13	Nut, 3/8-16 Wing	F05010-24 ²	2	
14	Base Weldment	W04710	1	
	Clamp Assembly, Moving	LTTSG-RF	1	
15	Plate, Moving Clamp	S04785	1	◆
16	Nut, 3/8-24 Hex Jam	F05010-22	1	
17	Washer, 1/4" SAE Flat	F05011-11	2	
18	Screw, 3/8-24 X 1 1/2" Socket Head Set Screw, Oval Point	F05007-98	1	
19	Nut, #10-24 Hex Lock	F05010-42	2	
20	Nut, 3/8-16 Jam	F05010-29	1	
21	Screw, #10-24 x 1" Socket Head Shoulder	F05004-7	2	
22	Screw, 3/8-16 X 1 1/2" Socket Head	F05007-36	1	
23	Spring, 1/2" x 1" Red Die	004750	2	
	Pawl Assembly, Left Adjustable Index (Includes 24-29)	A04732	1	
	Pawl Assembly, Right Adjustable Index (Includes 24-29)	A04736	1	
24	O-Ring, #007	P04577	1	
25	Pin, 1/8" X 3/4" Roll	F05012-6	1	
26	Shaft, Pawl Adjustment	M04629	1	
27	Block, Pawl Adjustment	S04733	1	
28	Pawl, Index	S04535	1	◆
29	Nut, 5/16-24 Wing	F05010-30	1	
30	Screw, 1/4-20 X 3/4" Socket Head	F05005-26	7	
31	Washer, 1/4" SAE Flat	F05011-11	4	
32	Screw, 1/4-20 X 1 1/4" Socket Head	F05005-48	2	
33	Spring, LC-045E-12	P04734	2	
	Tube Kit, Clamp Adjustment	A04717	1	
34	Tube, Adjusting	S04797	1	◆
35	Screw, #10-24 x 1/4" Wing	F05004-59	2	
20	Nut, 3/8-16 Hex Jam	F05010-29	1	
	Key, 5/16" Hex	P04701	1	
	Instruction Sheet, Clamp Adjustment Tube	A04717-519	1	
36	Bolt, 3/8" X 1 1/4" Shoulder (5/16-18 Thread)	F05006-70	2	
37	Shim, Toothsetter Clamp Holddown	S04778	1	
	Handle Kit, Toothsetter Extended Clamp	004746 ³	1	

38	Clamp, Push Pull	P04714	1	
	Handle Assembly, Toothsetter Clamp	004743 ⁴	1	
39	Handle, Toothsetter	004745	1	
40	Grip, 5/8" ID Hand	004742	1	
	Gauge Assembly, With Mount Block (Pre-aligned)	A04788	1	
41	Block, Toothsetter Gauge Mount	S04789	1	◆
	Gauge Indicator Assembly	A04782	1	◆
42	Gauge Dial, Indicator	P04780	1	◆
43	Foot, Gauge (Short .403")	P04716-2 ⁵	1	
44	Screw, 1/4-20 X 3/4" Socket Head	F05005-26	1	
45	Nut, 1/4-20 Hex Self-Locking	F05010-9	1	
46	Plate, Toothsetter Revision	005801-TS ⁶	1	◆
	Screw, #6 x 1/4" Drive	F05015-6	4	
	Stand Assembly	A04825 ²	1	
	Base Weldment, Toothsetter	W04849	1	◆
	Stand Weldment, Toothsetter	W04876	1	◆
	Leg Weldment, Base	W04882	1	◆
	Brace, Support	S04861	1	◆
	Bolt, 5/16-18 x 2 1/4" Hex Head Full Thread	F05006-16	2	
	Bolt, 5/16-18 x 2" Hex Head Full Thread	F05006-13	4	
	Washer, 5/16 SAE Flat	F05011-17	12	
	Washer, 5/16 Split Lock	F05011-13	6	
	Nut, 5/16-18 Free Hex	F05010-17	6	
	Instruction Sheet, Toothsetter Stand Assembly	A04825-497	1	◆
	EXTENSION KIT, BLADE SUPPORT ARM	A20912 ⁷	1	
47	Arm, Support Arm 12" Extension	S10625	4	
48	Coupler, 1/2" EMT Conduit	P04587	4	
	Instruction Sheet, Blade Support Arm Extension Kit	M20913-391	1	

¹ Push-handle style setter LTTSG no longer available. Replace with crank-handle style setter 004761).

² Toothsetter Stand A04825 redesigned 7/08 ([See Section 4.5](#)) to reduce parts and cost. New stand requires two F05010-1 3/8-16 Hex Nuts to replace F05010-24 Wing Nuts originally supplied (wing nuts interfere with new stand).

³ Handle can be retrofitted with current crank-style handle. Use retrofit kit 004765.

⁴ Replaces W04722 Push Pull Clamp Weldment and P04731 Hand Grip (LTTSG rev. F+).

⁵ Replaces P04716-1 supplied until 5/96. Foot face is ground flat.

⁶ Replaces P04846-1 (supplied LTTSG rev. F-J) and P04846 decal (supplied prior to LTTSG rev. F).

⁷ Includes parts to extend the left and right blade support arms of the sharpener and toothsetter to support longer blades. The rear support arms will not require an extension.

4 Replacement Parts

Toothsetter Parts

4.4 Toothsetter Parts

TSG

Rev. D

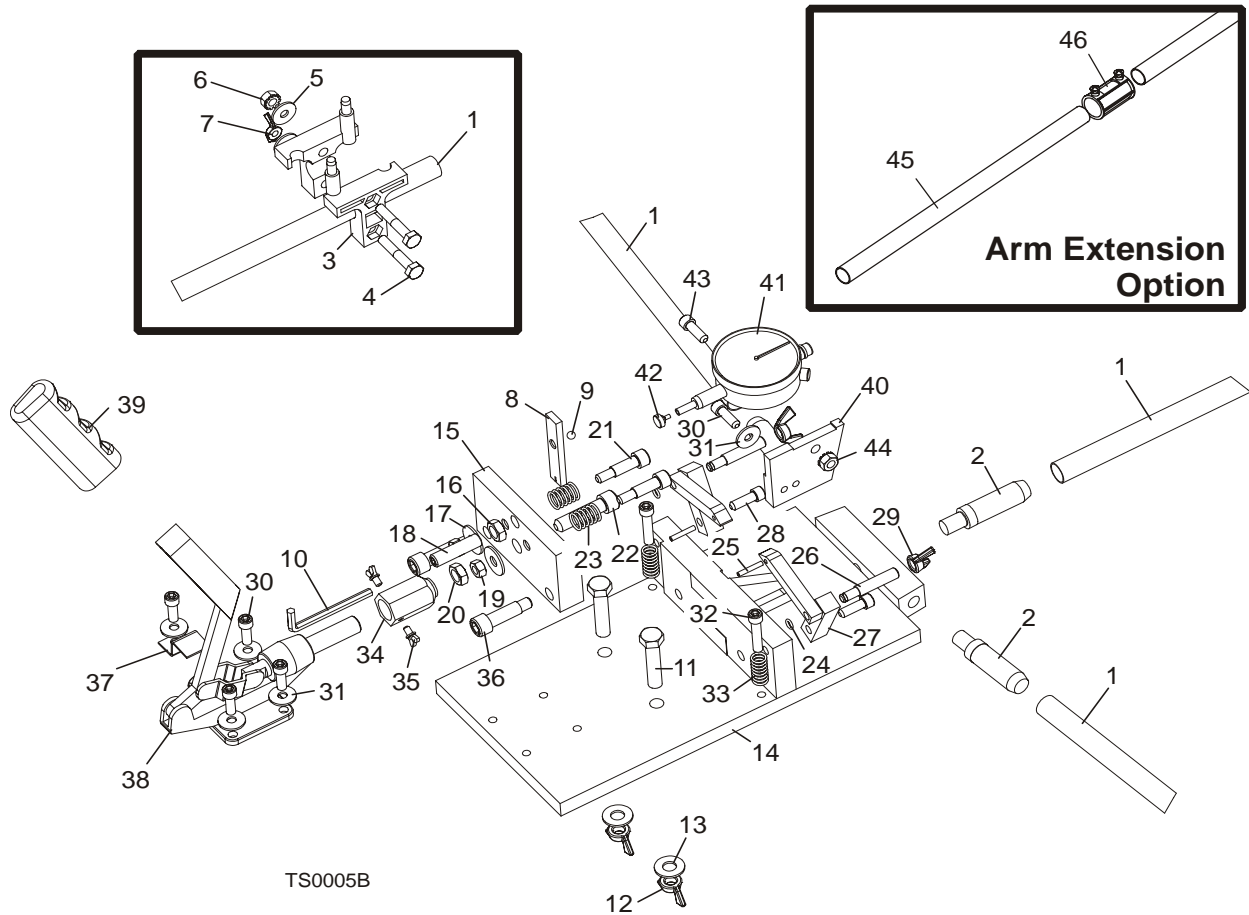

TS0005B

REF	DESCRIPTION (◆ Indicates Parts Available In Assemblies Only)	PART NUMBER	QTY.	
	TOOTHSETTER/GAUGE ASSY, COMPLETE WITH BLADE SUPPORT ARMS	LTTSG ¹	1	◆
	Arm Assembly, Blade Support	A04545	1	
	Tube Assembly, Blade Support	A04550	3	
1	Tube, Blade Support	M04551	1	◆
2	Plug, Tube Support	P04552	1	
	Blade Support Support Assembly, Replacement	A10617	1	
	Bag Assembly, Blade Support	A10615	1	
3	Guide W/Post, Blade Support	S10611	6	
4	Bolt, 1/4-20 X 1 1/2" Hex Head Grade 2	F05005-5	6	
5	Washer, 1/4" SAE Flat	F05011-11	6	
6	Nut, 1/4-20 Self-Locking	F05010-9	3	
7	Nut, 1/4-20 Wing	F05010-13	3	
	Toothsetter Assembly, Boxed	A04740 ¹	1	◆

	Toothsetter Assembly	A04709	1	◆
	Bar Assembly, Toothsetter Alignment	A04787	1	
8	Bar, Toothsetter Alignment	S04753	1	◆
9	Ball, 7/32" Chrome Steel	P04786	1	◆
10	Key, 3/16" Hex	P06147	1	
11	Bolt, 3.8-16 x 1 3/4" Hex Head	F05007-19	2	
12	Washer, 3/8" Flat	F05011-3	2	
13	Nut, 3/8-16 Wing	F05010-24 ²	2	
14	Base Weldment	W04710	1	
	Clamp Assembly, Moving	LTTSG-RF ³	1	
15	Plate, Moving Clamp	S04785	1	◆
16	Nut, 3/8-24 Hex Jam	F05010-22	1	
17	Washer, 5/16" SAE Flat	F05011-17	2	
18	Screw, 3/8-24 X 1 1/2" Socket Head Set Screw, Oval Point	F05007-98	1	
19	Nut, 1/4-20 Hex	F05010-63	2	
20	Nut, 3/8-16 Jam	F05010-29	1	
21	Screw, 5/16" X 3/4" Socket Head Shoulder	F05006-36	2	
22	Screw, 3/8-16 X 1 1/2" Socket Head	F05007-36	1	
23	Spring, LC063 G-4	P04779 ⁴	2	
	Pawl Assembly, Left Adjustable Index (Includes 24-29)	A04732	1	
	Pawl Assembly, Right Adjustable Index (Includes 24-29)	A04736	1	
24	O-Ring, #007	P04577	1	
25	Pin, 1/8" X 3/4" Roll	F05012-6	1	
26	Shaft, Pawl Adjustment	M04629	1	
27	Block, Pawl Adjustment	S04733	1	
28	Pawl, Index	S04535	1	◆
29	Nut, 5/16-24 Wing	F05010-30	1	
30	Screw, 1/4-20 X 3/4" Socket Head	F05005-26	7	
31	Washer, 1/4" SAE Flat	F05011-11	4	
32	Screw, 1/4-20 X 1 1/4" Socket Head	F05005-48	2	
33	Spring, LC-045E-12	P04734	2	
	Tube Kit, Clamp Adjustment	A04717	1	
34	Tube, Adjusting	S04797	1	◆
35	Screw, #10-24 x 1/4" Wing	F05004-59	2	
20	Nut, 3/8-16 Hex Jam	F05010-29	1	
	Key, 5/16" Hex	P04701	1	
	Instruction Sheet, Clamp Adjustment Tube	A04717-519	1	
36	Bolt, 3/8" X 1" Shoulder (5/16-18 Thread)	F05006-25	2	
37	Shim, Toothsetter Clamp Holddown	S04778	1	
38	Clamp Weldment, Push/Pull	W04722 ⁵	1	◆
39	Grip, Hand	P04731	1	
	Gauge Assembly, With Mount Block (Pre-aligned)	A04788	1	
40	Block, Toothsetter Gauge Mount	S04789	1	◆

4

Replacement Parts

Toothsetter Parts

	Gauge Indicator Assembly	A04782	1	◆
41	Gauge Dial, Indicator	P04780	1	◆
42	Foot, Gauge (Short .403")	P04716-2 ⁶	1	
43	Screw, 1/4-20 X 3/4" Socket Head	F05005-26	1	
44	Nut, 1/4-20 Hex Self-Locking	F05010-9	1	
	Stand Assembly	A04825 ²	1	
	Base Weldment, Toothsetter	W04849	1	◆
	Stand Weldment, Toothsetter	W04876	1	◆
	Leg Weldment, Base	W04882	1	◆
	Brace, Support	S04861	1	◆
	Bolt, 5/16-18 x 2 1/4" Hex Head Full Thread	F05006-16	2	
	Bolt, 5/16-18 x 2" Hex Head Full Thread	F05006-13	4	
	Washer, 5/16 SAE Flat	F05011-17	12	
	Washer, 5/16 Split Lock	F05011-13	6	
	Nut, 5/16-18 Free Hex	F05010-17	6	
	Instruction Sheet, Toothsetter Stand Assembly	A04825-497	1	◆
	EXTENSION KIT, BLADE SUPPORT ARM	A20912 ⁷	1	
45	Arm, Support Arm 12" Extension	S10625	4	
46	Coupler, 1/2" EMT Conduit	P04587	4	
	Instruction Sheet, Blade Support Arm Extension Kit	M20913-391	1	

¹ Push-handle style setter LTTSG no longer available. Replace with crank-handle style setter 004761).

² Toothsetter Stand A04825 redesigned 7/08 ([See Section 4.5](#)) to reduce parts and cost. New stand requires two F05010-1 3/8-16 Hex Nuts to replace F05010-24 Wing Nuts originally supplied (wing nuts interfere with new stand).

³ Clamp includes heavier springs and hardware. [See Section 4.3](#).

⁴ Heavy Spring retrofit available. Kit 004741 includes springs and mounting hardware for TSG Rev. A-D.

⁵ Replace obsolete W04722 with handle kit 004746. [See Section 4.3](#). Handle can be retrofitted with current crank-style handle. Use retrofit kit 004765.

⁶ Replaces P04716-1 supplied until 5/96. Foot face is ground flat.

⁷ Includes parts to extend the left and right blade support arms of the sharpener and toothsetter to support longer blades. The rear support arms will not require an extension.

4.5 Stand Assembly

TSG

Retrofit

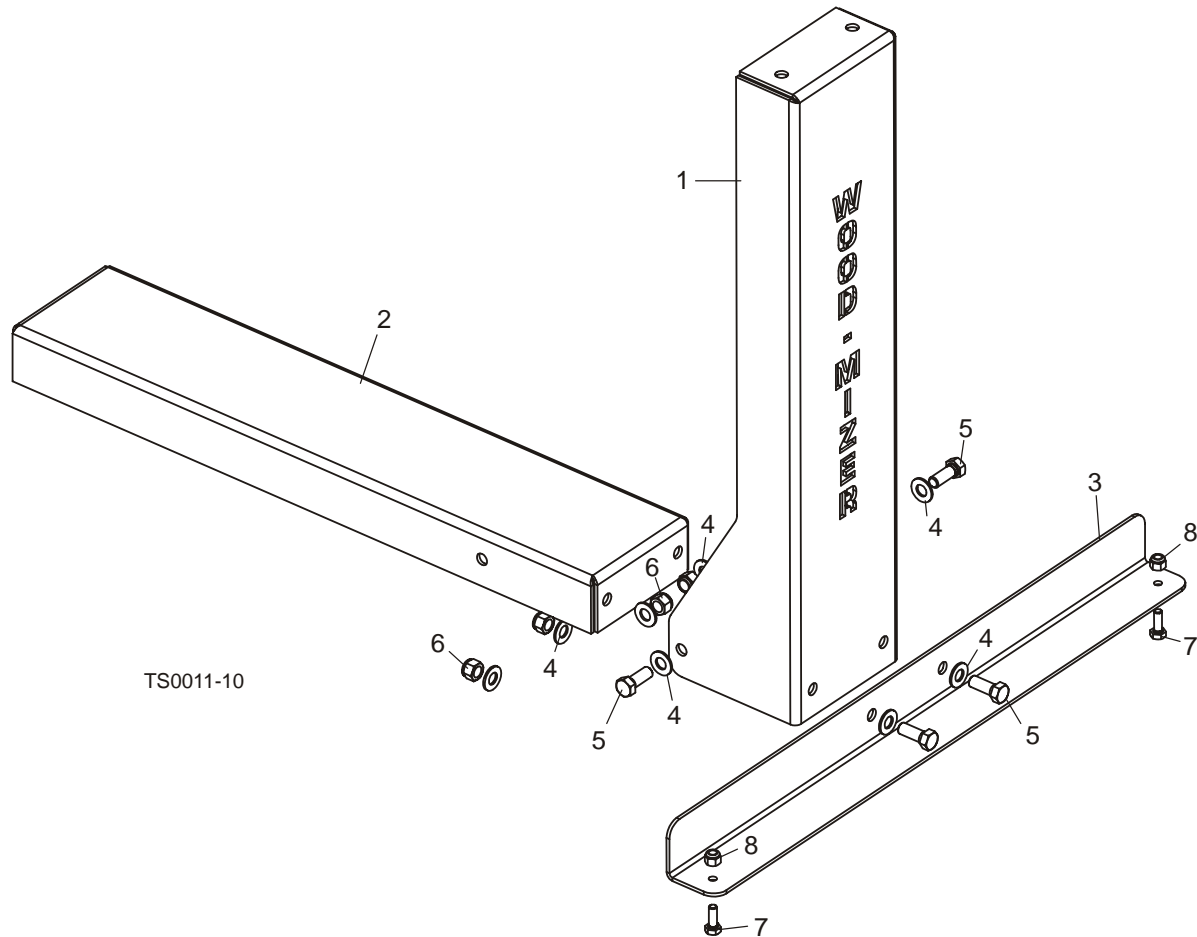

TS0011-10

REF	DESCRIPTION (◆ Indicates Parts Available In Assemblies Only)	PART NUMBER	QTY.	
	STAND ASSEMBLY	A04825	1	
1	Post Weldment, Toothsetter Stand	057903	1	
2	Channel, Toothsetter Stand Base	057901	1	
3	Angle, Toothsetter Stand Base	057904	1	
	Bag Assembly, Toothsetter Stand	057902	1	
4	Washer, 3/8" SAE Flat	F05011-3	8	
5	Bolt, 3/8-16 x 1" Hex Head Grade 5	F05007-87	4	
6	Nut, 3/8-16 Hex Nylon Lock	F05010-10	4	
7	Bolt, 1/4-20 x 3/4" Hex Head Grade 5	F05005-123	2	
8	Nut, 1/4-20 Hex Nylon Lock	F05010-69	2	
	Instruction Sheet, Toothsetter Stand Assembly	A04825-497	1	◆

SECTION 5 MAINTENANCE

5.1 Toothsetter Maintenance

- Keep the toothsetter clean.
- Keep all moving parts lubricated with a light penetrating oil.
- Remove the clamping assembly occasionally and clean any debris that may have collected between the clamping plates.

INDEX

D

deburring the blade 1-2

M

maintenance 5-1

O

operation

 adjustments 3-3

 blade installation 3-1

 toothsetter operation 3-5

overview 1-1

R

replacement parts 4-2

 stand assembly 4-8

S

setup 2-1

 blade support installation 2-2

 dial indicator 2-3

 toothsetter mount 2-1