

Wood-Mizer[®] Toothsetter

Safety, Operation, Parts & Maintenance Manual

TSG-C

Rev. C.00



Safety is our #1 concern! Read and understand all safety information and instructions before operating, setting up or maintaining this machine.

Form #1028

Table of Contents

Section-Page

SECTION 1	OVERVIEW	1-1
1.1	Toothsetter/Gauge Introduction.....	1-1
1.2	Deburring The Blade	1-2
SECTION 2	SETUP	2-1
2.1	Toothsetter Mount	2-1
2.2	Blade Support Installation	2-3
2.3	Dial Indicator Setup.....	2-5
SECTION 3	OPERATION	3-1
3.1	Blade Installation.....	3-1
3.2	Toothsetter Adjustments.....	3-3
3.3	Toothsetter Operation.....	3-5
SECTION 4	REPLACEMENT PARTS	4-1
4.1	How To Use The Parts List	4-1
4.2	Sample Assembly	4-1
4.3	Toothsetter Parts.....	4-2
4.4	Toothsetter Assembly.....	4-3
4.5	Blade Support Arms	4-6
4.6	Stand Assembly.....	4-7
SECTION 5	MAINTENANCE	5-1
5.1	Toothsetter Maintenance	5-1
	INDEX	I

SECTION 1 OVERVIEW

1.1 Toothsetter/Gauge Introduction

There are four steps to maintaining blades used on the Wood-Mizer sawmill. They should ALWAYS be followed in this order:

1. Blade Cleaning
2. Sharpening
3. Deburring
4. Toothsetting

See Figure 1-1. The blades supplied by Wood-Mizer have a raker-style set in the teeth. If you look at a blade from the top, you will see that the teeth are set (or bent out) in a repeating sequence; straight, left and right. The teeth that are set left and right do the cutting. The straight teeth (rakers) clear the cut of sawdust.

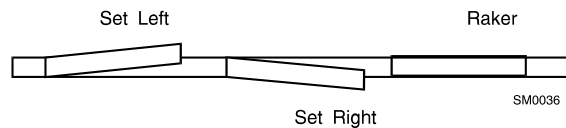

FIG. 1-1

See Figure 1-2. As the blade is sharpened, the tip of the tooth recedes and the set becomes smaller. Correct setting is one of the most important factors in the cutting ability of a blade. Check used blades regularly to see if they need resetting.

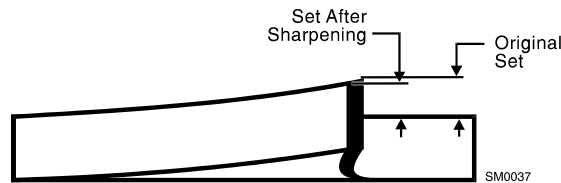

FIG. 1-2

The Toothsetter/Gauge (TSG) provided in the Blade Maintenance Package allows you to accurately and evenly set the teeth of a bandsaw blade. The spring-loaded clamping mechanism lets you position a tooth in front of the gauge and clamp it in place. You can then measure the set. The tooth is bent by clamping the blade further. This chapter describes proper setup and operation of the toothsetter.

1.2 Deburring The Blade

Sharpening leaves tiny metal burrs on the back side of the teeth. New blades also have burrs. These burrs **MUST** be removed before the set is checked. If they are not removed, they may cause the toothsetter to give false readings.

To remove burrs, take the blade from the Sharpener. Invert it, so that the inside of the blade is facing out. Drag a stick of hardwood across the blade in the opposite direction that the teeth cut. (Use the weld in the blade as a reference point for starting and stopping.)

Cutting with the blade also removes burrs. If the blade you are about to set has been used after sharpening, you will not need to deburr it. Clean the blade before removing from the mill by running the Water Lube Option for 15 seconds. Remove the blade and wipe dry with a rag to prevent rusting.

SECTION 2 SETUP

2.1 Toothsetter Mount

Install the crank handle to the toothsetter crank assembly using the supplied hex head bolt. Be sure the handle is oriented in the "up" position as shown. Install the crank handle knob to the crank handle using the provided socket head bolt and two hex nuts.

Mount the toothsetter to the stand. Use the mounting holes found in the base plate of the setting fixture. Use the provided bolts (inserting the bolts down through the top of the mounting plate), hex nuts and washers. Setup the toothsetter so that there is at least 32" (81.0 cm) to the rear and to either side of the tool. This allows enough room for the blade supports.

See Figure 2-1.

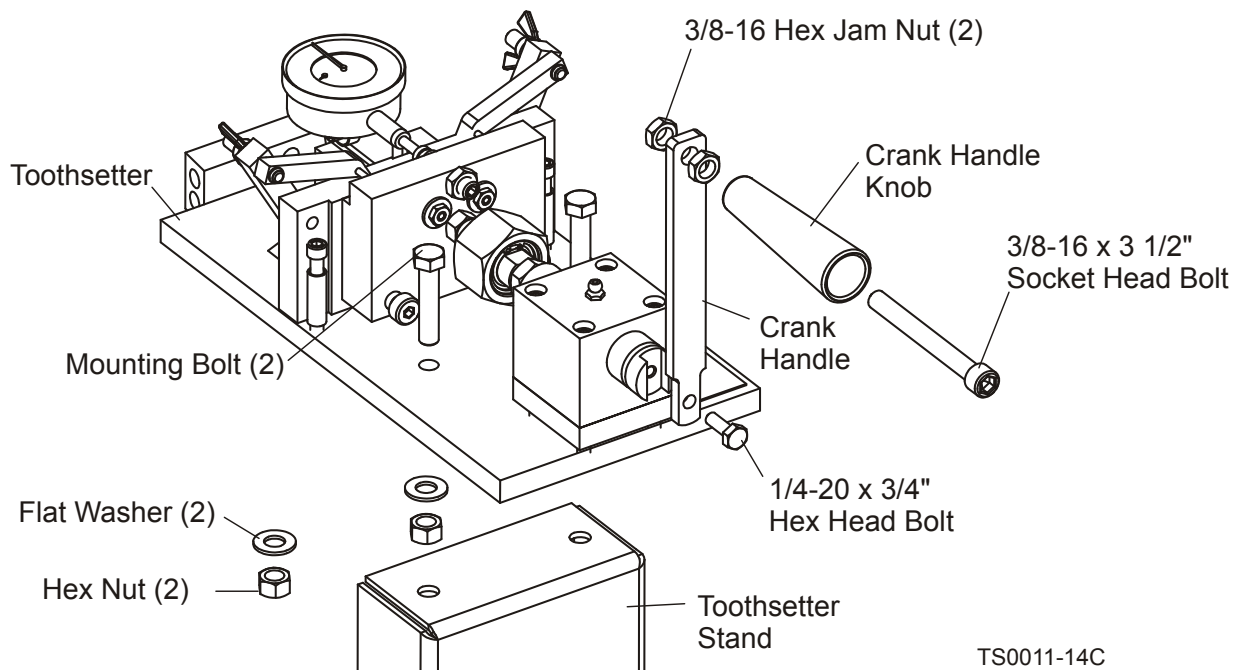

FIG. 2-1

2 Setup Toothsetter Mount

See **Figure 2-2**. The main components of the toothsetter are shown below. These parts will be discussed in the following instructions.

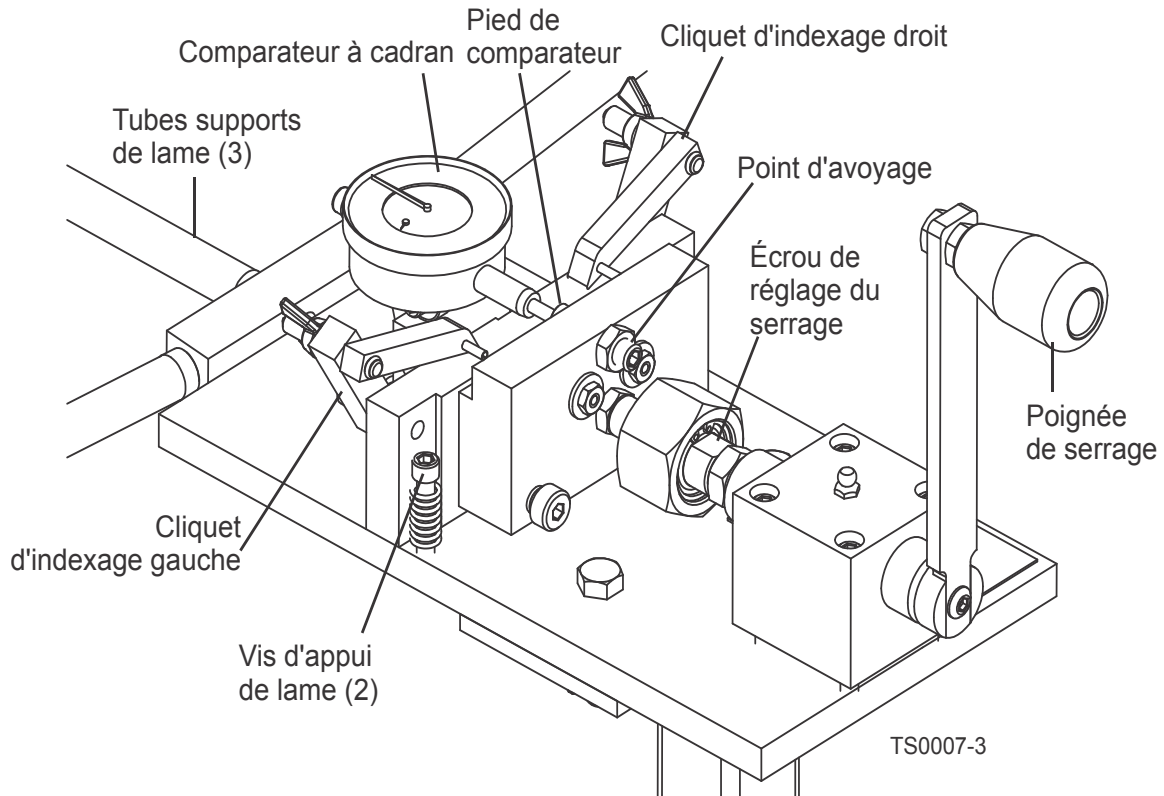

FIG. 2-2

2.2 Blade Support Installation

Attach the three blade support arms to the threaded mounting bar at the rear of the tooth-setter. Two sets of support arm mounting holes are provided. Use the upper set of holes for 1 1/4" & 1 1/2" wide blades. Use the lower set of holes for 1 3/4" & 2" wide blades.

See Figure 2-3.

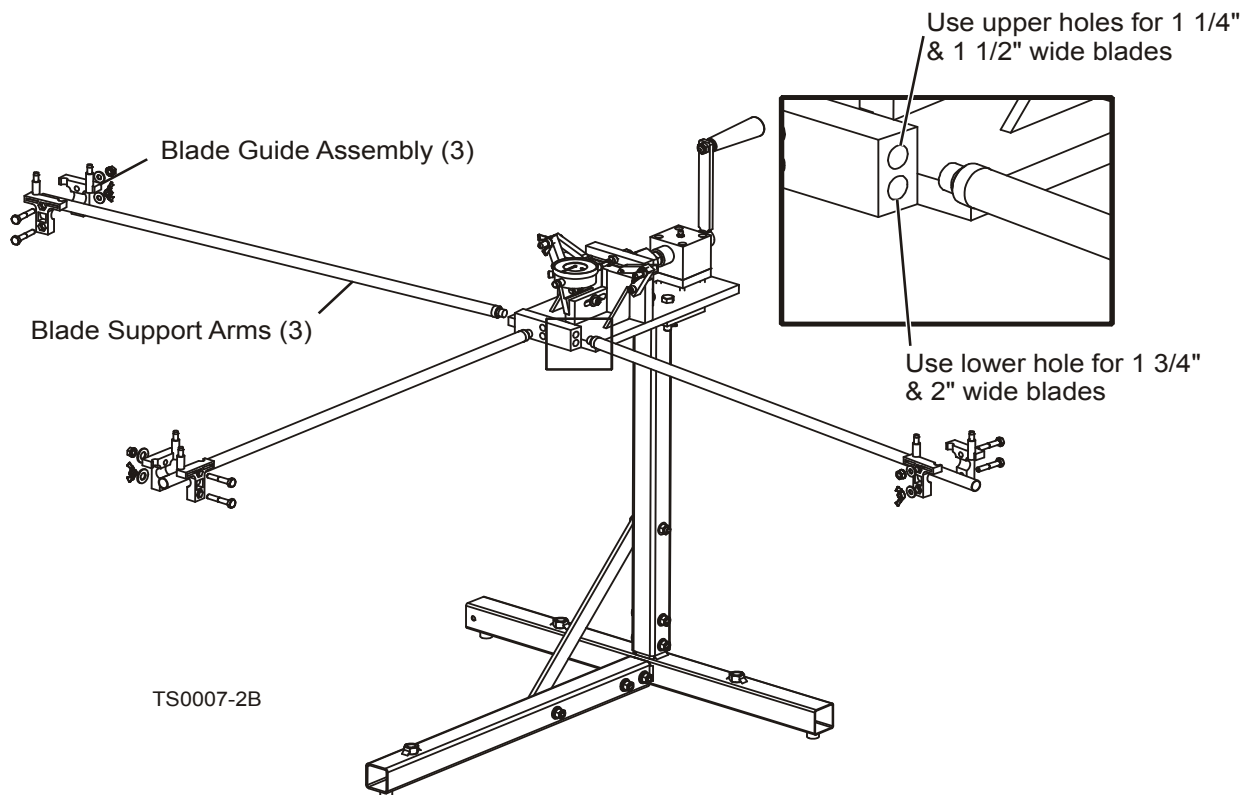

FIG. 2-3

2

Setup

Blade Support Installation

See Figure 2-4. Assemble a blade support guide onto the end of each blade support arm. Bolt from the hexed side of the guide assembly. Tighten the top bolts with the self-locking nuts. Tighten the bottom bolts with the wing nuts.

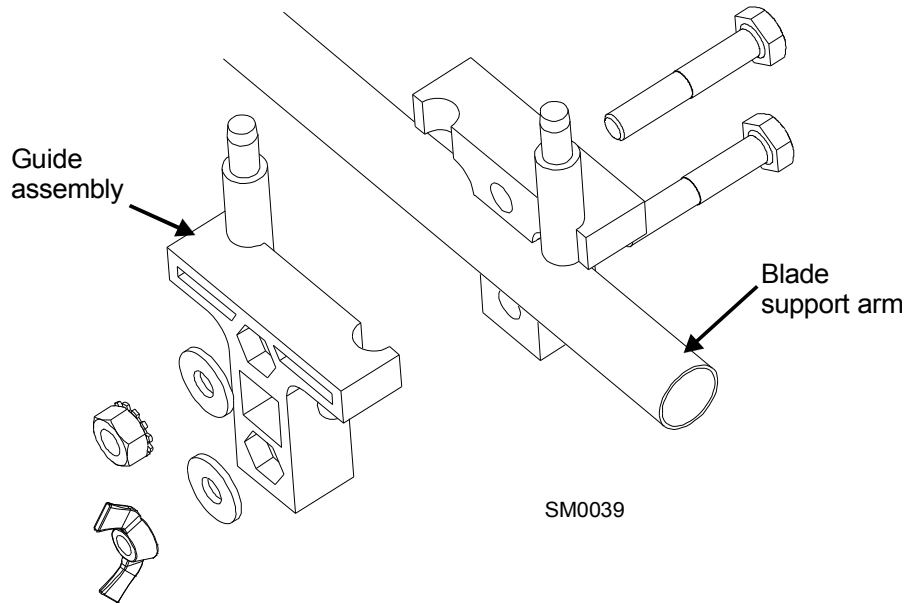

FIG. 2-4

The guides should be about 1" (2.5 cm) from the ends of the right and rear tubes and about 2.5" (6.0 cm) from the end of the left tube. Final adjustments will be made later.

2.3 Dial Indicator Setup

To set the dial indicator, follow these steps.

See Figure 2-5.

1. **Back the setting point out of the way.** Insert the hex key in the end of the setting contact point shaft and turn counterclockwise until the setting contact point is behind the front edge of the moving clamping plate.
2. **Adjust the Dial Indicator.** Clamp the gauge pin between the clamping plates. The pin should be touching the center of the gauge foot.

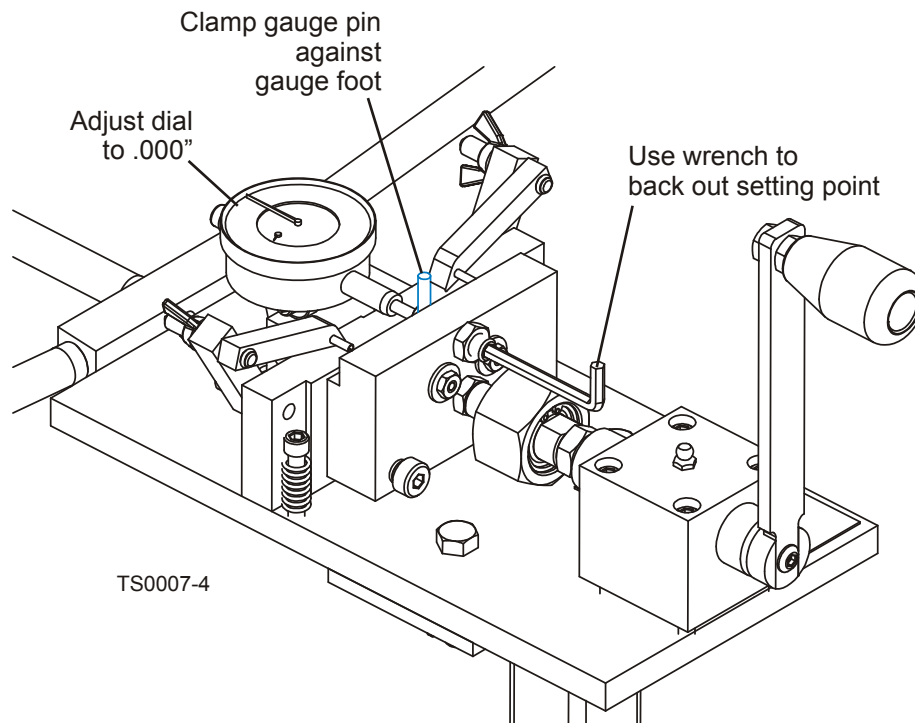

FIG. 2-5

The dial indicator should read 0. If the dial indicator does not show 0, loosen the dial lock on the upper right side of the dial indicator. Rotate the dial indicator to 0 and retighten the dial lock.

Now, remove the gauge pin from the toothsetter clamp. The dial indicator should now read between $-.001$ and $-.005$.

See Figure 2-6. If the dial indicator does not read between $-.001$ and $-.005$ with nothing

clamped, you will need to adjust the indicator position:

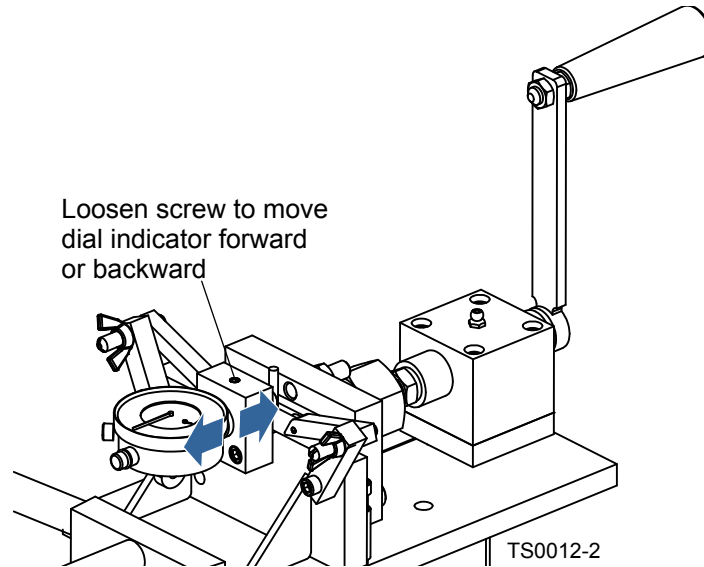

FIG. 2-6

3. Reclamp the gauge pin centered on the gauge foot.
4. Loosen the locking screw at the top of the indicator mounting block. Move the indicator assembly back until the gauge foot does not touch the gauge pin.
5. Move the indicator assembly forward so the gauge foot touches the gauge pin and the gauge needle moves .001 - .005. Retighten the mounting block screw.
6. Rotate the dial face until the gauge reads zero.
7. Unclamp the gauge pin. The indicator should now read -.001 to -.005. If not, repeat steps 3 - 6.

SECTION 3 OPERATION

Once the toothsetter alignments have been checked and adjustments have been made, you are ready to measure and set blades.

Sharpening removes metal from the face of the tooth. This eventually reduces the set to a point where the blade will not cut very well. Set should not vary more than $(\pm)0.001$ from one tooth to the next and $(\pm)0.001$ from one side of the blade to the other side.

The following steps will take you through operation of the toothsetter.

Note: Refer to the [Wood-Mizer® Blade Handbook](#) for recommended set specifications for your sawing application.

3.1 Blade Installation

1. **Clean the blade and deburr before putting it in the toothsetter.** Otherwise, sap buildup on the blade or tooth will give false set readings. Metal burrs created by sharpening also will cause false readings.
2. **Mount the blade in the toothsetter.** Place blade between the clamping plates and on the three guide assemblies.

NOTE: You will need to move both the left and right index pawl assemblies down and out of the way. These will be adjusted later.

3

Operation

Blade Installation

- 3. Adjust crank handle for desired setting location.** The handle can be adjusted so that when the setting point contacts the blade, the handle is located in a desirable position. Loosen the jam nut on the crank handle shaft and rotate the adjustment nut to move it in or out to relocate the handle position. Retighten the jam nut.

See Figure 3-1.

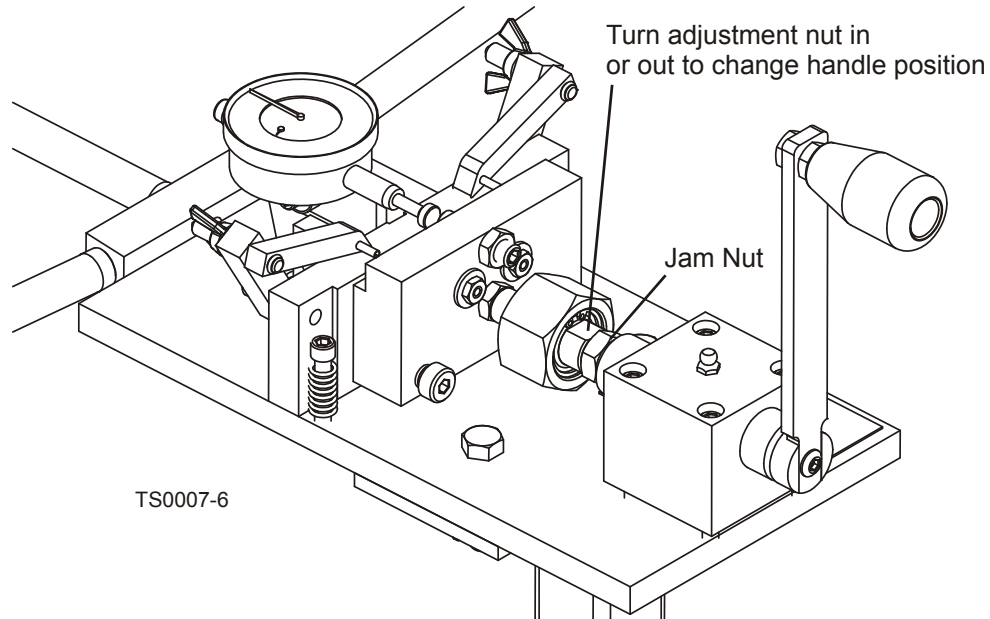

FIG. 3-1

3.2 Toothsetter Adjustments

See Figure 3-2.

1. **Adjust the blade rest screws.** Rest the blade evenly on the two blade rest screws on each side of the clamp. Adjust the rest screws until the gullet of the blade lies just above the top of the clamp plates. (Deburring will remove burrs from the back side of the teeth, but may not remove burrs from the gullet area. Keeping the gullet out of the clamp assembly helps to assure accurate readings.)

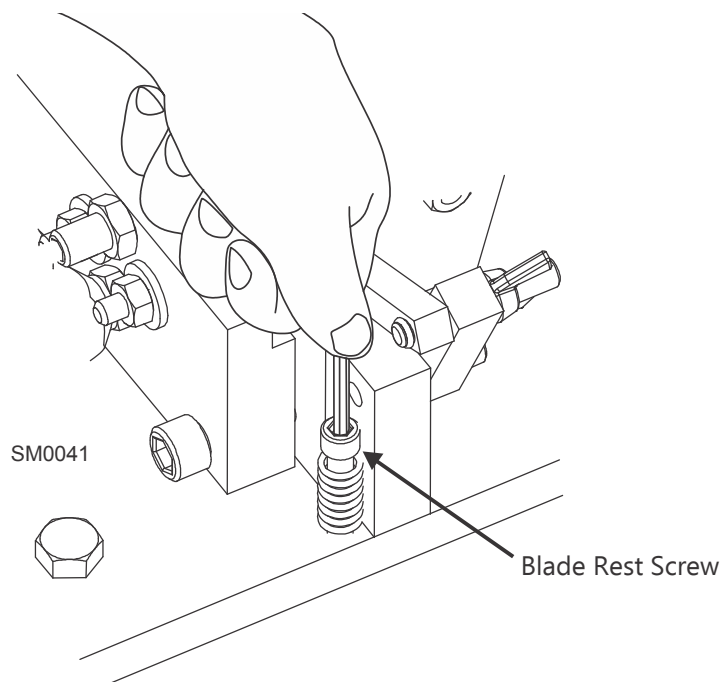

FIG. 3-2

2. **Make final adjustments to blade support arms and guide assemblies.** Adjust to assure the blade travels smoothly. Blade should rest on rear guide, but should not touch the bottom of either side guide assembly.
3. **Adjust the setting contact point.** Position the blade so the gauge foot is in between two teeth. Use the hex key to bring the setting contact point towards the gauge foot until the dial indicator reads 15-20 thousandths.

4. **Position the blade.** Turn the blade to bring a weld into the clamping/setting assembly. Use the weld as a reference point for starting and stopping. Start with the first tooth to the right (See NOTE) of the weld that has been set back toward the dial indicator.

NOTE: The toothsetter sets and measures the teeth which are set away from the operator and towards the dial indicator. To measure teeth set in the opposite direction, invert the blade and insert it in the toothsetter.

See Figure 3-3. Position that tooth in front of the gauge foot so the its edge is aligned with the center of the setting point.

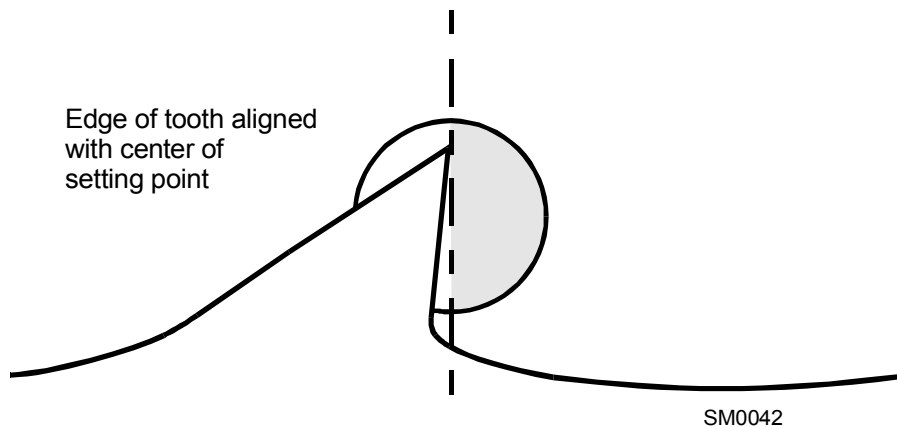

FIG. 3-3

5. **The index pawls are factory-set for Wood-Mizer® Industrial blades with 7/8" tooth spacing.** Check the right (or left if the blade is inverted) side index pawl is firmly against the tooth two teeth to the right (or left) of the one being set. To adjust, loosen the index pawl screw with the hex key provided and move the pawl tight against the tooth. Retighten the screw.

3.3 Toothsetter Operation

NOTE: These instructions assume you are setting the blade starting with the blade not inverted. Set the first side of the blade using the right index pawl. After setting the first side of the blade, invert the blade and use the left index pawl when setting the other side of the blade.

1. **Set the blade.** Measure set by turning the crank handle clockwise, clamping the blade between the back clamping plate and the spring-loaded pins on the front clamping plate. Remember set should not vary more than $(\pm)0.001$ from one tooth to the next.

To add set, continue turning the crank handle to clamp in further on the blade. This brings the setting contact point against the tooth. The amount you will need to bend the tooth forward to get the desired set will vary. Recheck set and adjust as needed.

To decrease set, bend the tooth back with the slot in the correction tool provided. Recheck set and adjust as needed.

Slide the blade to the right until the third tooth from the one just set comes in front of the gauge foot. Push this tooth firmly against the index pawl. Check set by lightly cranking the handle until the spring-loaded pins in the clamping assembly push the blade against the back plate. Read the dial indicator. Adjust set as necessary (see above). Check every third tooth until you reach the weld.

2. **Set the opposite side of blade.** Remove the blade and invert it. Put the blade back in the toothsetter with the teeth pointing to the left. Repeat the above steps to set the teeth using the left side index pawl assembly. The amount that you must bend the teeth to end up with the same set as the first side of the blade probably will differ.
3. **Remove the blade.** Take the blade out of the toothsetter. Be sure the blade is turned to the correct side before putting it on the sawmill.

SECTION 4 REPLACEMENT PARTS

4.1 How To Use The Parts List

- Use the index above to locate the assembly that contains the part you need.
- Go to the appropriate section and locate the part in the illustration.
- Use the number pointing to the part to locate the correct part number and description in the table.
- Parts shown indented under another part are included with that part.
- Parts marked with a diamond (◆) are only available in the assembly listed above the part.

See the sample table below. Sample Part #A01111 includes part F02222-2 and subassembly A03333. Subassembly A03333 includes part S04444-4 and subassembly K05555. The diamond (◆) indicates that S04444-4 is not available except in subassembly A03333. Subassembly K05555 includes parts M06666 and F07777-77. The diamond (◆) indicates M06666 is not available except in subassembly K05555.

4.2 Sample Assembly				
REF	DESCRIPTION (◆ Indicates Parts Available In Assemblies Only)	PART #	QTY.	
	Sample Assembly, Complete (Includes All Indented Parts Below)	A01111	1	
1	Sample Part	F02222-22	1	
	Sample Subassembly (Includes All Indented Parts Below)	A03333	1	
2	Sample Part (◆ Indicates Part Is Only Available With A03333)	S04444-4	1	◆
	Sample Subassembly (Includes All Indented Parts Below)	K05555	1	
3	Sample Part (◆ Indicates Part Is Only Available With K05555)	M06666	2	◆
4	Sample Part	F07777-77	1	

To Order Parts:

- From the continental U.S., call **1-800-525-8100** to order parts. Have your customer number, serial number, and part numbers ready when you call.
- From other international locations, contact the Wood-Mizer distributor in your area for parts.

4.3 Toothsetter Parts

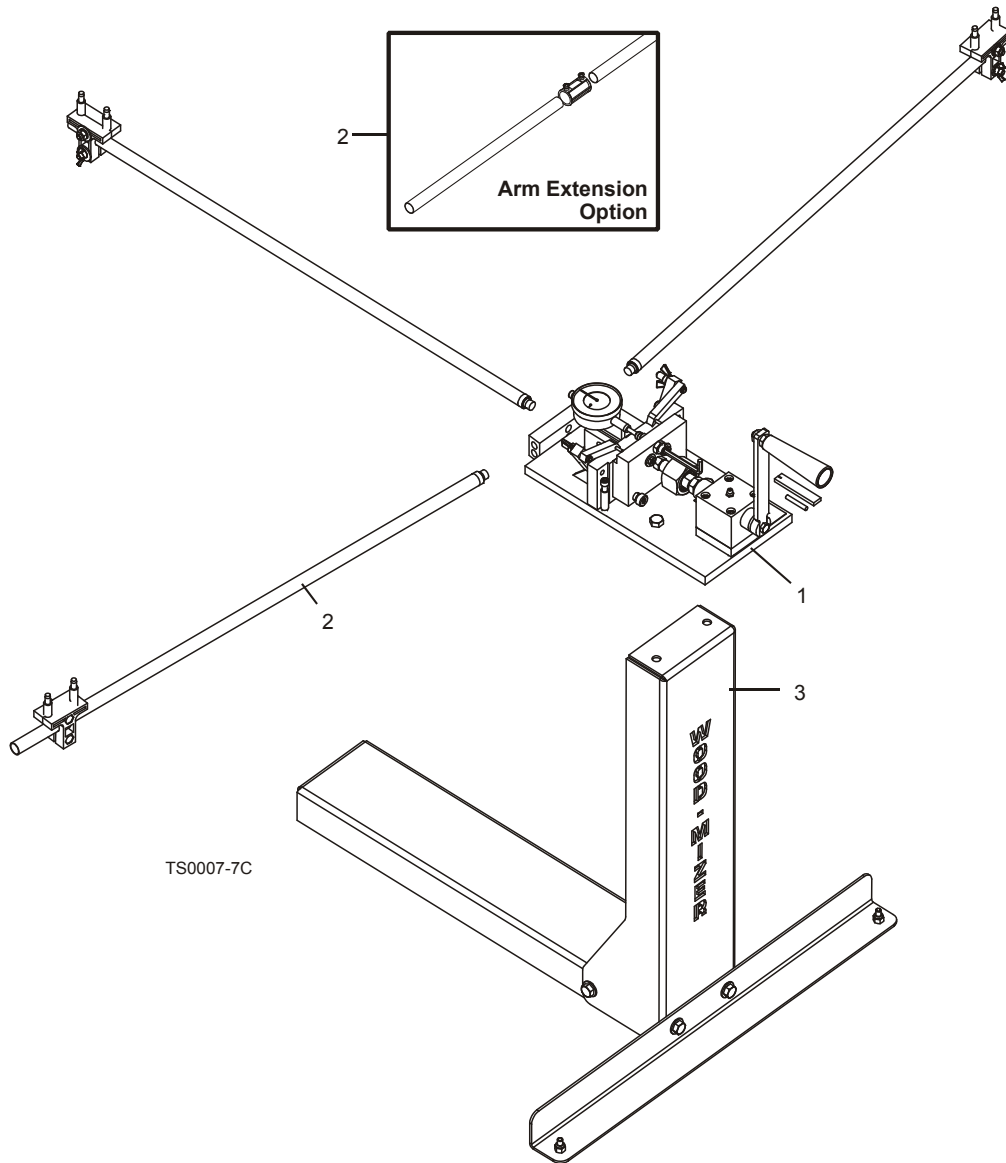

TS0007-7C

REF	DESCRIPTION (◆ Indicates Parts Available In Assemblies Only)	PART NUMBER	QTY.
	TOOTHSETTER KIT, CRANK-STYLE W/STAND AND BLADE ARMS	LTTSG-C	1
1	Toothsetter Parts (See Section 4.4)		
2	Blade Support Arm Parts (See Section 4.5)		
3	Stand Parts (See Section 4.6)		
	Manual, Blade Handbook	M600	1

4 Replacement Parts

Toothsetter Assembly

4.4 Toothsetter Assembly

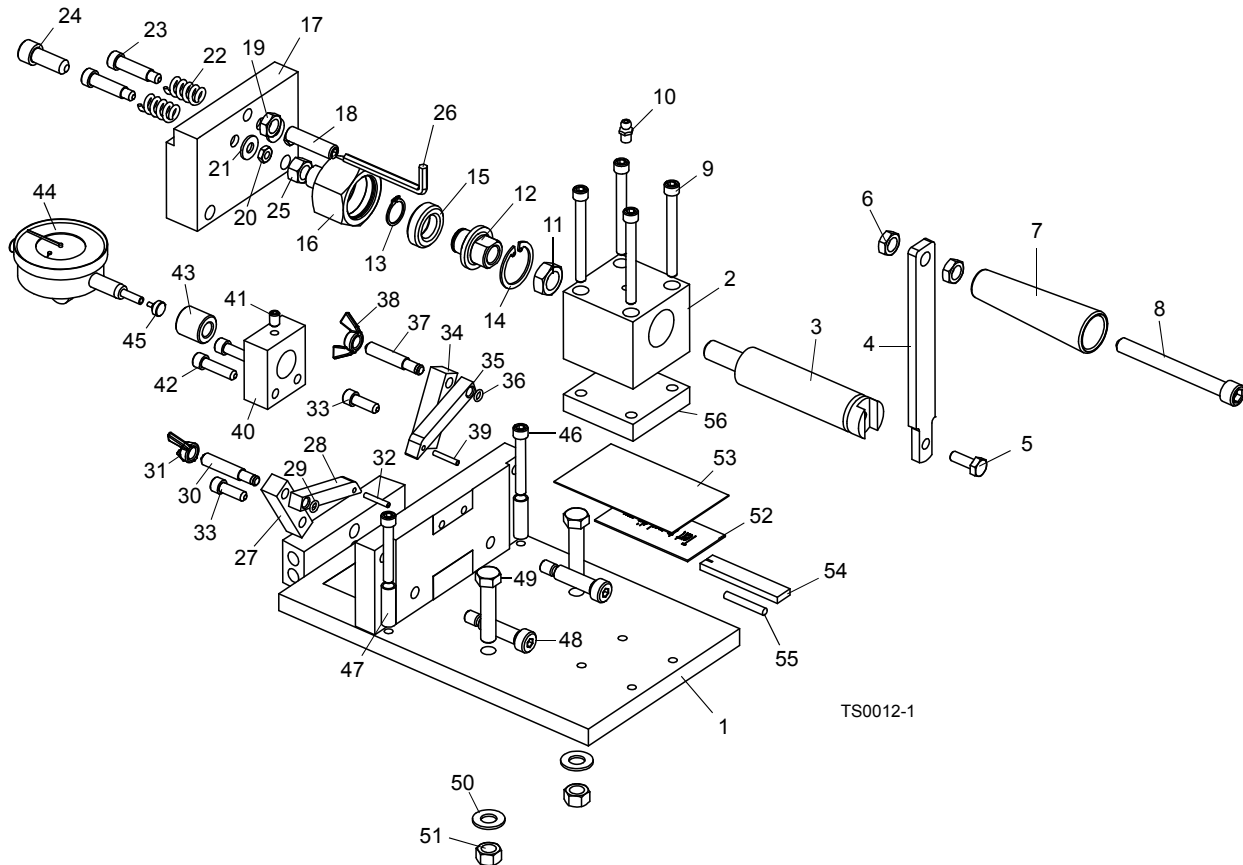

REF	DESCRIPTION (◆ Indicates Parts Available In Assemblies Only)	PART NUMBER	QTY.
	TOOTHSETTER ASSEMBLY, BOXED CRANK-STYLE	004761	1
1	Base Weldment, Toothsetter	W04710	1
	Crank Assembly, Toothsetter	004764	1
2	Block, Toothsetter Crank Mount	004800	1
3	Screw, Toothsetter Crank Acme	004803	1
4	Handle, Toothsetter Crank	004804	1
5	Bolt, 1/4-20 x 3/4" Hex Head Grade 5	F05005-123	1
6	Nut, 3/8-16 Hex Jam	F05010-29	2
7	Knob, 3/8" Bore Tapered Plastic	060170	1
8	Bolt, 3/8-16 x 3 1/2" Socket Head	F05007-111	1
9	Bolt, 1/4-20 x 2 1/2" Socket Head	F05005-179	4

10	Fitting, 1/4-28 Grease	P05060	1	
11	Nut, 1/2-20 Hex Jam	F05010-15	1	
12	Spinner, Toothsetter Crank	004802	1	
13	Ring, 5/8" 5100-62 Outside Retaining	F04254-2	1	
14	Ring, 1 1/8" Tru-Ark Inside Retaining	F04254-1	1	
15	Bearing, 5/8" Thrust	P04214	1	
16	Housing, Toothsetter Crank Spinner	004801	1	
	Clamp Assembly, Crank Toothsetter Moving	060167	1	
17	Plate, Toothsetter Moving Clamp	060168	1	
18	Screw, 3/8-24 x 1 1/2" Oval Point Socket Set	F05007-98	1	
19	Nut, 3/8-24 Hex Jam	F05010-22	1	
20	Nut, #10-24 Hex Lock	F05010-42	2	
21	Washer, 1/4" SAE Flat	F05011-11	2	
22	Spring, 1/2" x 1" Red Die	004750	2	
23	Bolt, #10-24 x 1" Shoulder	F05004-7	2	
24	Bolt, 3/8-16 x 1" Socket Head	F05007-52	1	
25	Nut, 3/8-16 Hex Lock	F05010-25	1	
26	Wrench, 3/16" Hex	P06147	1	
	Pawl Assembly, Left Index	A04732	1	
27	Block, Pawl Adjustment	S04733	1	
28	Pawl, Index	S04535	1	◆
29	O-Ring, #007	P04577	1	
30	Shaft, Pawl Adjustment	M04629	1	
31	Nut, 5/16-24 Wing	F05010-30	1	
32	Pin, 1/8" X 3/4" Roll	F05012-6	1	
33	Bolt, 1/4-20 x 3/4" Socket Head	F05005-26	3	
	Pawl Assembly, Right Index	A04736	1	
34	Block, Pawl Adjustment	S04733	1	
35	Pawl, Index	S04535	1	◆
36	O-Ring, #007	P04577	1	
37	Shaft, Pawl Adjustment	M04629	1	
38	Nut, 5/16-24 Wing	F05010-30	1	
39	Pin, 1/8" X 3/4" Roll	F05012-6	1	
40	Block, Toothsetter Gauge Mount	061769	1	
41	Screw, 1/4-20 x 3/8" Half Dog Socket Set	F05005-108	1	
42	Bolt, 1/4-20 X 1" Socket Head	F05005-84	1	
	Gauge Assembly, Toothsetter Indicator	061771	1	
43	Bushing, Gauge Stem	032329	1	
44	Gauge Dial, Indicator	P04780	1	◆
45	Foot, Gauge (Short .403")	P04716-2	1	
46	Bolt, 1/4-20 x 1 3/4" Socket Head	F05005-156	2	
47	Spring, LC-038E-15SS	P22041	2	
48	Bolt, 3/8 x 1 1/4" Shoulder	F05006-70	2	

4**Replacement Parts***Toothsetter Assembly*

49	Bolt, 3/8-16 x 1 3/4" Hex Head Full Thread	F05007-19	2	
50	Washer, 3/8" SAE Flat	F05011-3	2	
51	Nut, 3/8-16 Hex	F05010-1	2	
52	Decal, LTTSG-C Revision	016187-TSC	1	
53	Overlayment, Revision Decal	016200	1	
54	Tool, Set Correction	004754	1	
55	Pin, 3/16" x 1 1/4" Dowel	F05012-60	1	
56	Spacer, Toothseter Crank Handle Mount	060173	1	
	Manual, LTTSG-C Operator's	M1028	1	

4.5 Blade Support Arms

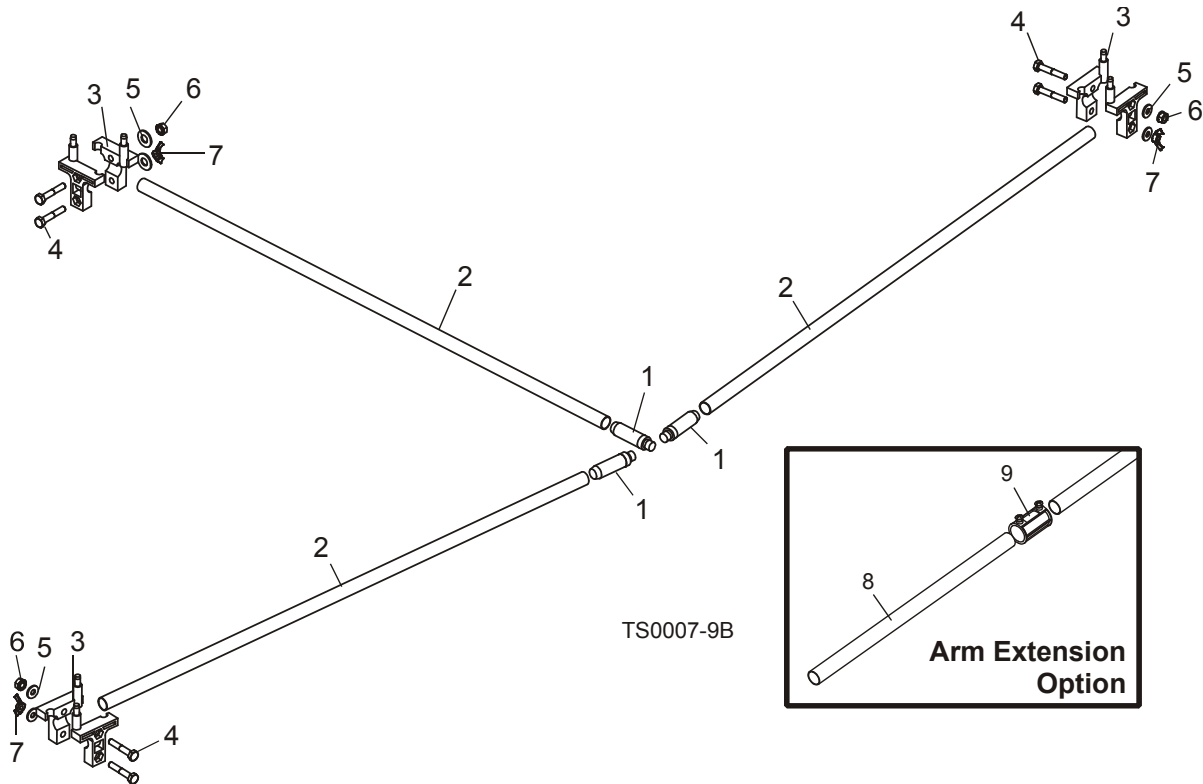

REF	DESCRIPTION (◆ Indicates Parts Available In Assemblies Only)	PART NUMBER	QTY.
	ARM KIT, BLADE SUPPORT	A04545	1
	Tube Assembly, Blade Support	A04550	3
1	Plug, Tube Support	P04552	1
2	Tube, Blade Support	M04551	1 ◆
	Blade Support Support Assembly, Replacement	A10617	1
	Bag Assembly, Blade Support	A10615	1
3	Guide W/Post, Blade Support	S10611	6
4	Bolt, 1/4-20 X 1 1/2" Hex Head Grade 2	F05005-5	6
5	Washer, 1/4" SAE Flat	F05011-11	6
6	Nut, 1/4-20 Self-Locking	F05010-9	3
7	Nut, 1/4-20 Wing	F05010-13	3
	EXTENSION KIT, BLADE SUPPORT ARM	A20912 ¹	1
8	Arm, Support Arm 12" Extension	S10625	4
9	Coupler, 1/2" EMT Conduit	P04587	4
	Instruction Sheet, Blade Support Arm Extension Kit	M20913-391	1

¹ Includes parts to extend the left and right blade support arms of the sharpener and toothsetter to support longer blades. The rear support arms will not require an extension.

4 Replacement Parts

Stand Assembly

4.6 Stand Assembly

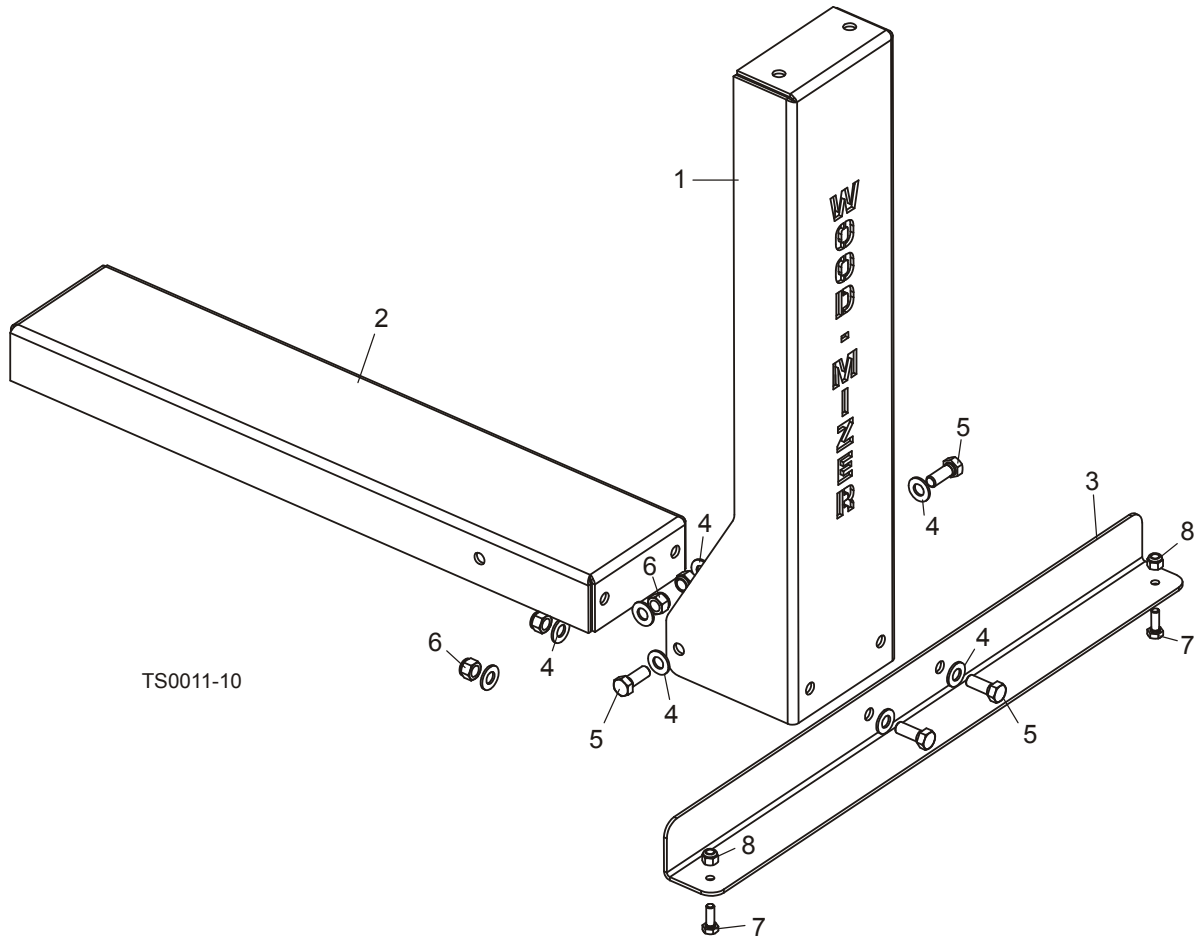

REF	DESCRIPTION (◆ Indicates Parts Available In Assemblies Only)	PART NUMBER	QTY.	
	STAND ASSEMBLY	A04825	1	
1	Post Weldment, Toothsetter Stand	057903	1	
2	Channel, Toothsetter Stand Base	057901	1	
3	Angle, Toothsetter Stand Base	057904	1	
	Bag Assembly, Toothsetter Stand	057902	1	
4	Washer, 3/8" SAE Flat	F05011-3	8	
5	Bolt, 3/8-16 x 1" Hex Head Grade 5	F05007-87	4	
6	Nut, 3/8-16 Hex Nylon Lock	F05010-10	4	
7	Bolt, 1/4-20 x 3/4" Hex Head Grade 5	F05005-123	2	
8	Nut, 1/4-20 Hex Nylon Lock	F05010-69	2	
	Instruction Sheet, Toothsetter Stand Assembly	A04825-497	1	◆

SECTION 5 MAINTENANCE

5.1 Toothsetter Maintenance

- Keep the toothsetter clean.
- Keep all moving parts lubricated with a light penetrating oil.
- Remove the clamping assembly occasionally and clean any debris that may have collected between the clamping plates.
- Apply grease to the fitting on the crank housing as needed so the crank turns easily.

See Figure 5-1.

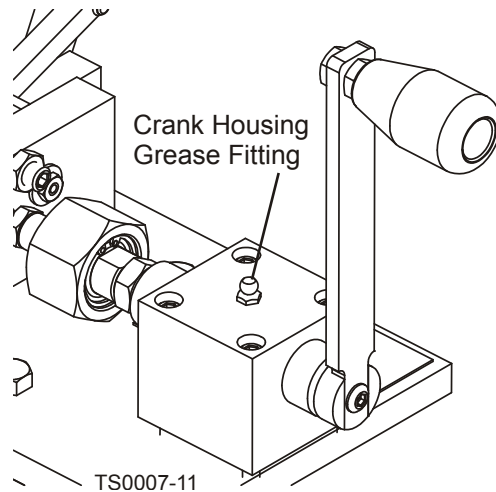

FIG. 5-1

INDEX

D

deburring the blade 1-2

M

maintenance 5-1

O

operation

adjustments 3-3

blade installation 3-1

toothsetter operation 3-5

overview 1-1

R

replacement parts 4-2

blade support arms 4-6

stand assembly 4-7

toothsetter assembly 4-3

S

setup 2-1

blade support installation 2-3

toothsetter mount 2-1