

## **APPENDIX A G25 ELECTRICAL INFORMATION**

**LX150**

**Rev. A3.01+**

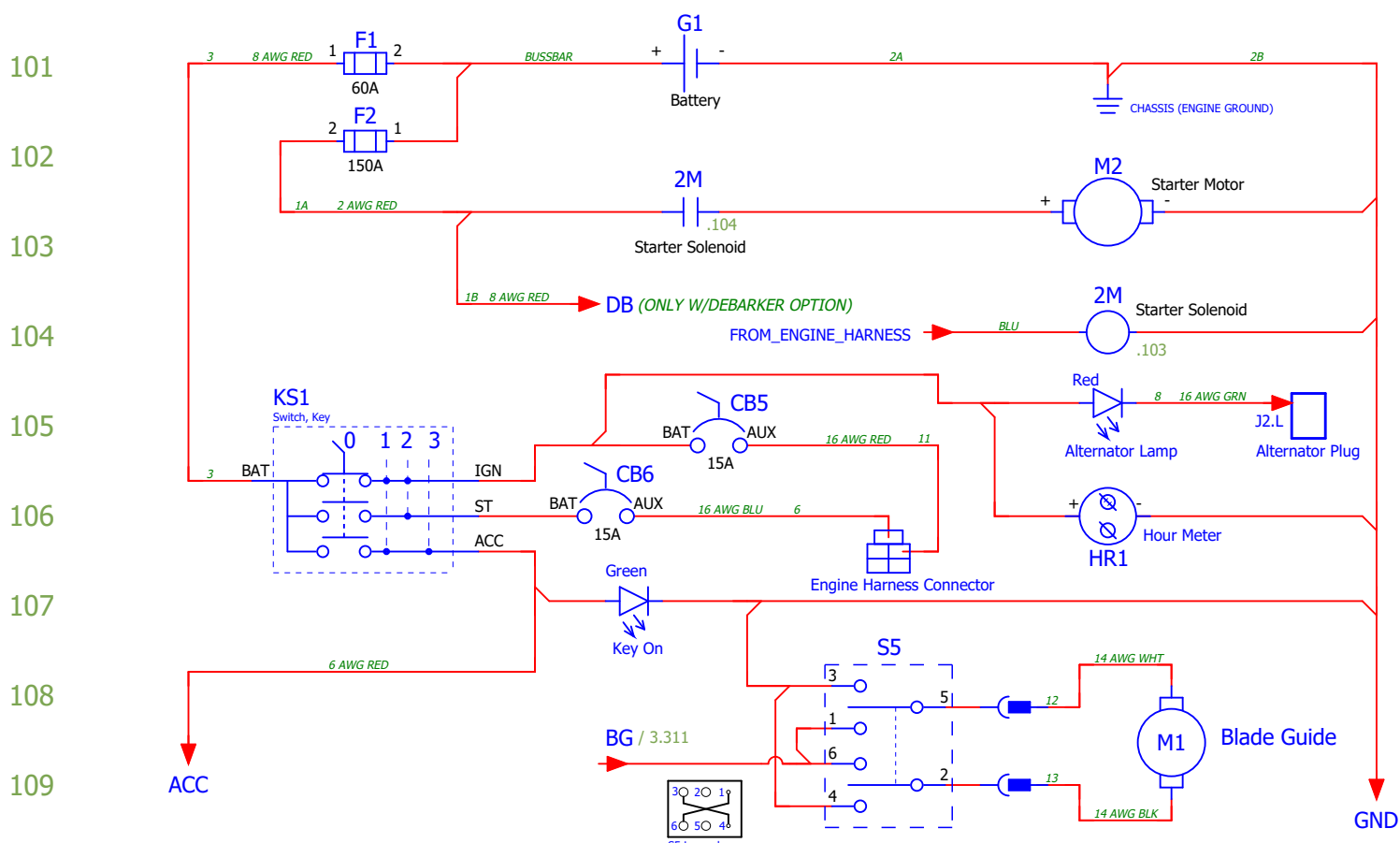

Equipped with SimpleSet

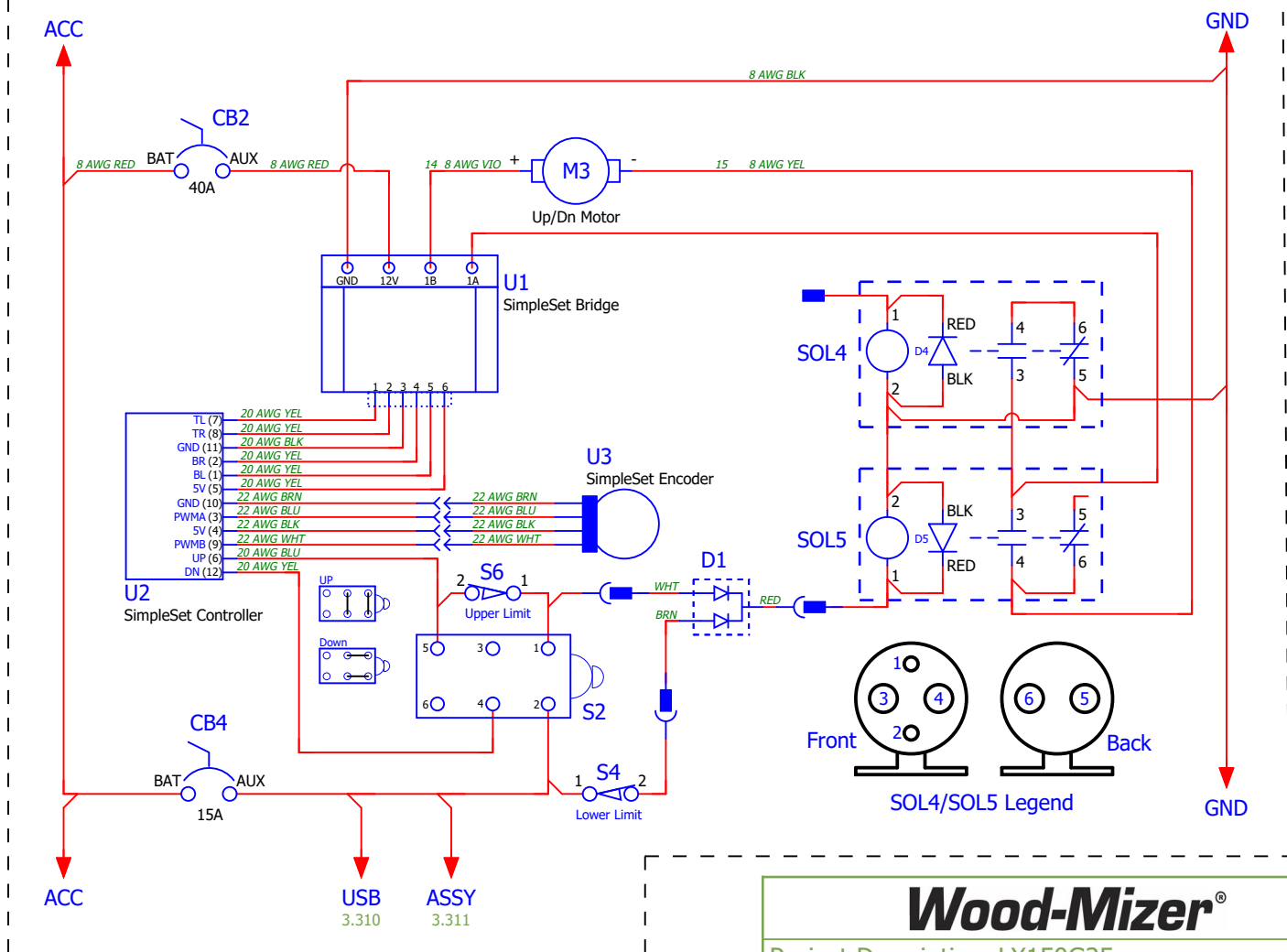

**Wood-Mizer®**

Project Description: LX150G25			
Revision:	+	Pg Desc:	
Mounting Location:		Type:	Schematic multi-line
Prev. pg:	Page:	1	Next pg: 2 Total Pgs: 5

201  
202  
203  
204  
205  
206  
207  
208  
209  
210  
211  
212  
213  
214  
215  
216  
217  
218  
219  
220  
221

Without SimpleSet Option

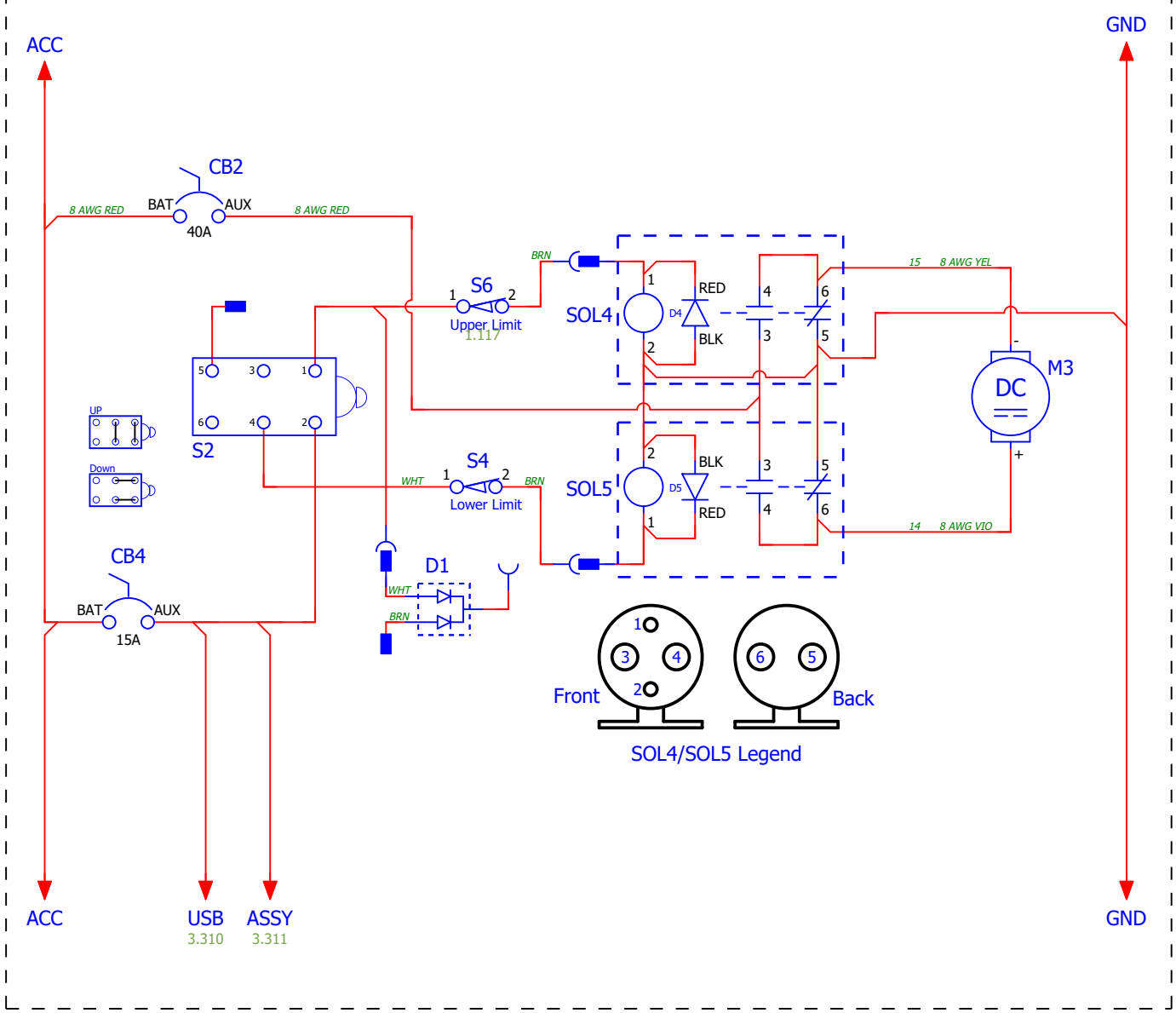

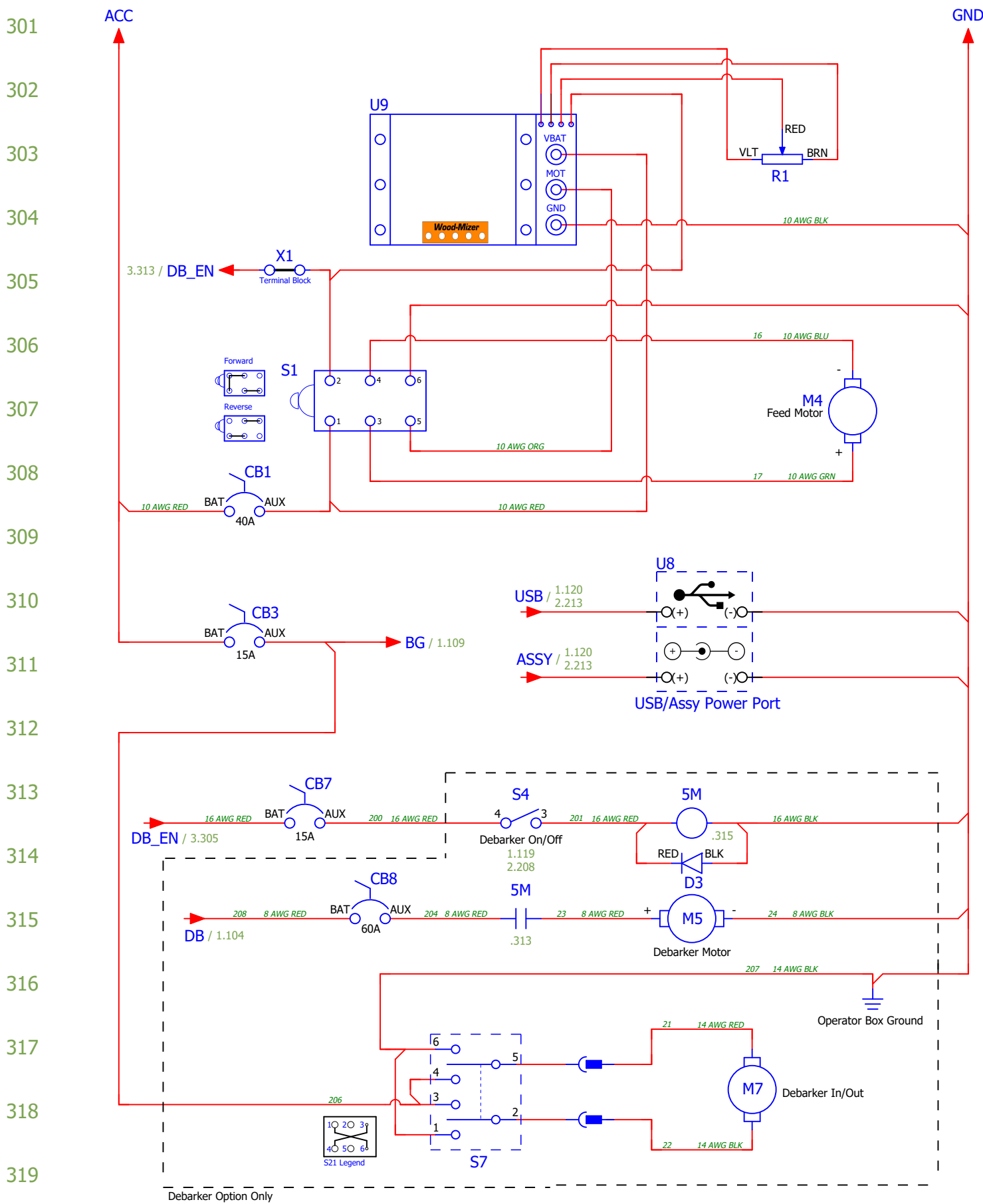

# Wood-Mizer®

Project Description: LX150G25			
Revision:		Pg Desc:	
Mounting Location:	+	Type:	Schematic multi-line
Prev. pg:	2	Page:	3
		Next pg:	C1
		Total Pgs:	5



# Terminal line-up diagram

**Terminal strip X1**

Terminal				Jumper		End Plate	Remark	Terminal
Ref. Des.	Level	P/N	Description	Diagram	P/N	P/N		X-Ref
		052293	Junction Block, 3-Position Wire Clamp	•				3.05
				•				