

# **Wood-Mizer®**

## **Replacement Parts**

---

**LX50 Start EH5S**

**rev.B1.02**

**LX50 Start G9**

**rev. B1.02**

---



**Safety is our #1 concern!** Read and understand all safety information and instructions before operating, setting up or maintaining this machine.

*Form #819*



# Table of Contents

# Section-Page

<b>SECTION 1</b>	<b>GENERAL INFORMATION</b>	<b>1-1</b>
1.1	How To Use the Parts List.....	1-1
1.2	Sample Assembly .....	1-1
<b>SECTION 2</b>	<b>BED FRAME</b>	<b>2-1</b>
2.1	Bed Frame, LX50 SA (No. 550652) .....	2-1
2.2	Bed Frame Section (No. 550651) .....	2-2
2.3	Bed Frame Section (No. 550650) .....	2-3
2.4	Bed Foot (514997) .....	2-4
2.5	Bed Frame Connection Bracket (No. X100-1271) .....	2-5
2.6	Clamp Assy., LX50SA (No. 586950) .....	2-6
2.7	End Stop Assembly (No. X100-1274) .....	2-7
2.8	Segment Joining Bracket (No. 550702) .....	2-8
2.9	Bed Frame Extension, LX50 (No. LX50SA-EXT2) .....	2-9
2.10	Bed Frame Extension w/Side Support (No. LX50SA-EXT-S2) .....	2-10
2.11	Loading Ramp Assembly 097483 .....	2-11
2.12	Log taper wedge X100-1304 (130005 for American market) .....	2-12
<b>SECTION 3</b>	<b>SAW HEAD</b>	<b>3-1</b>
3.1	Saw Head (LX50SA, No. 557345) .....	3-2
3.2	Blade Height Scale (No. 530667) .....	3-4
3.3	Up/Down Slide (No. 550699) .....	3-5
3.4	Cable Guide Roller (No. 550817) .....	3-6
3.5	Wheel Assembly (No. X100-961) .....	3-7
3.6	Blade Guide Assembly, Drive Side (No. 593254) .....	3-8
3.7	Blade Guide Assembly, Idle Side (No. 593258) .....	3-9
3.8	Tensioner Assembly (595710) .....	3-10
<b>SECTION 4</b>	<b>SAWMILL MAST</b>	<b>4-1</b>
4.1	Sawmill Mast, LX50SA (No. 594395) .....	4-2
4.2	Horizontal Bearing Assembly (Option) (No. X100-1135) .....	4-4
4.3	Assy, Carriage Wheel (No. X100-1136) .....	4-5
4.4	Sweeper Assembly (No. X100-1260) .....	4-6
4.5	Additional Equipment - Left (No. 550419-S) .....	4-7
4.6	Additional Equipment - Right .....	4-8
4.7	Tensioner Assembly (No. X100-1246) .....	4-9
4.8	Complete Up/Down Shaft (No. 550693) .....	4-11
4.9	Winch Crank Handle, LX50 SA .....	4-12
4.10	Water Bottle, 10l (No. 550744) .....	4-13
4.11	Motor Kit, LX50SA E5 (No. 557356) .....	4-14
4.12	Electrical Box Base (No. 594391) .....	4-15
4.13	Electrical Box, LX50 SA (No. 526996) .....	4-17

## Table of Contents

## Section-Page

4.14	Engine Kit, G9 LX50SA (No. 557357) .....	4-18
4.15	Lever clutch 594396 .....	4-20

## SECTION 1 GENERAL INFORMATION

### 1.1 How To Use the Parts List

- Use the index above to locate the assembly that contains the part you need.
- Go to the appropriate section and locate the part in the illustration.
- Use the number pointing to the part to locate the correct part number and description in the table.
- Parts shown indented under another part are included with that part.
- Parts marked with a diamond (◆) are only available in the assembly listed above the part.

See the sample table below. Sample Part #A01111 includes part F02222-2 and subassembly A03333. Subassembly A03333 includes part S04444-4 and subassembly K05555. The diamond (◆) indicates that S04444-4 is not available except in subassembly A03333. Subassembly K05555 includes parts M06666 and F07777-77. The diamond (◆) indicates M06666 is not available except in subassembly K05555.

<b>1.2 Sample Assembly</b>				
REF.	DESCRIPTION (◆ Indicates Parts Available In Assemblies Only)	PART #	QTY	
	Sample Assembly, Complete (Includes All Indented Parts Below)	A01111	1	
1	Sample Part	F02222-22	1	
	Sample Subassembly (Includes All Indented Parts Below)	A03333	1	
2	Sample Part (◆ Indicates Part Is Only Available With A03333)	S04444-4	1	◆
	Sample Subassembly (Includes All Indented Parts Below)	K05555	1	
3	Sample Part (◆ Indicates Part Is Only Available With K05555)	M06666	2	◆
4	Sample Part	F07777-77	1	

#### **To Order Parts:**

- From Europe call our European Headquarters and Manufacturing Facility in Kolo, Poland at **+48-63-2626000**. From the continental U.S., call our toll-free Parts hotline at **1-800-525-8100**. Have your customer number, vehicle identification number, and part numbers ready when you call. From other international locations, contact the Wood-Mizer distributor in your area for parts.

#### **Office Hours:**

Country	Monday - Friday	Saturday	Sunday
Poland	7-15	Closed	Closed
US	8 a.m.- 5 p.m.	8 a.m.- 12 p.m.	Closed



**CAUTION!** It is strongly recommended that only original spare parts be used.

## SECTION 2 BED FRAME

### 2.1 Bed Frame, LX50 SA (No. 550652)

550652\_001  
550652

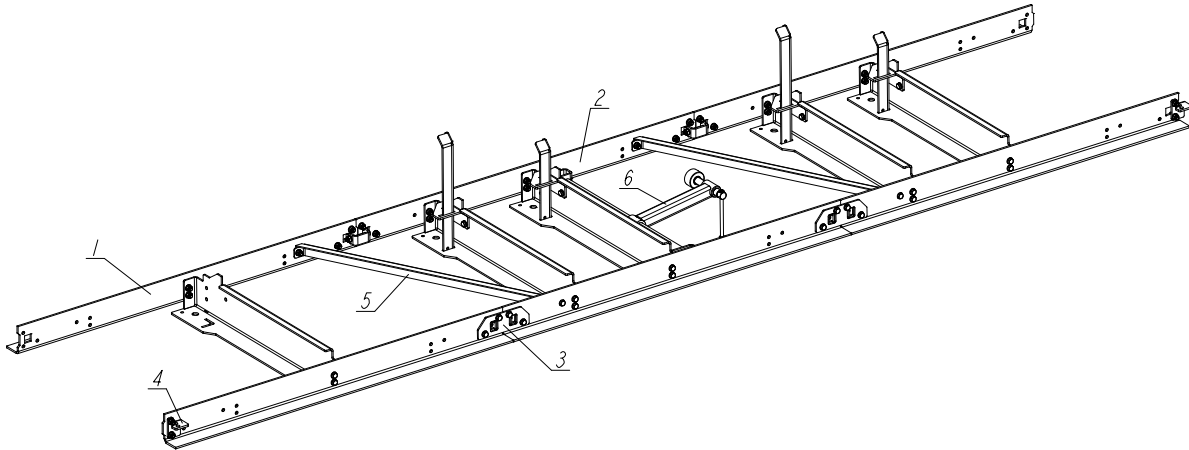

REF	DESCRIPTION (u indicates parts available in assemblies only)	PART #	QTY	
-	FRAME, LX50SA BED - COMPLETE	550652	1	
1	SECTION, BED FRAME - COMPLETE <a href="#">See Section 2.2</a>	550651	1	
2	SECTION, BED FRAME - COMPLETE <a href="#">See Section 2.3</a>	550650	2	
3	ASSY., BED CONNECTION <a href="#">See Section 2.5</a>	X100-1271	4	
4	ASSY., END STOP <a href="#">See Section 2.7</a>	X100-1274	2	
5	BRACKET, SEGMENT JOINING <a href="#">See Section 2.8</a>	550702	2	
6	CLAMP ASSY. <a href="#">See Section 2.6</a>	586950	1	

## 2.2 Bed Frame Section (No. 550651)

550651\_001  
550651

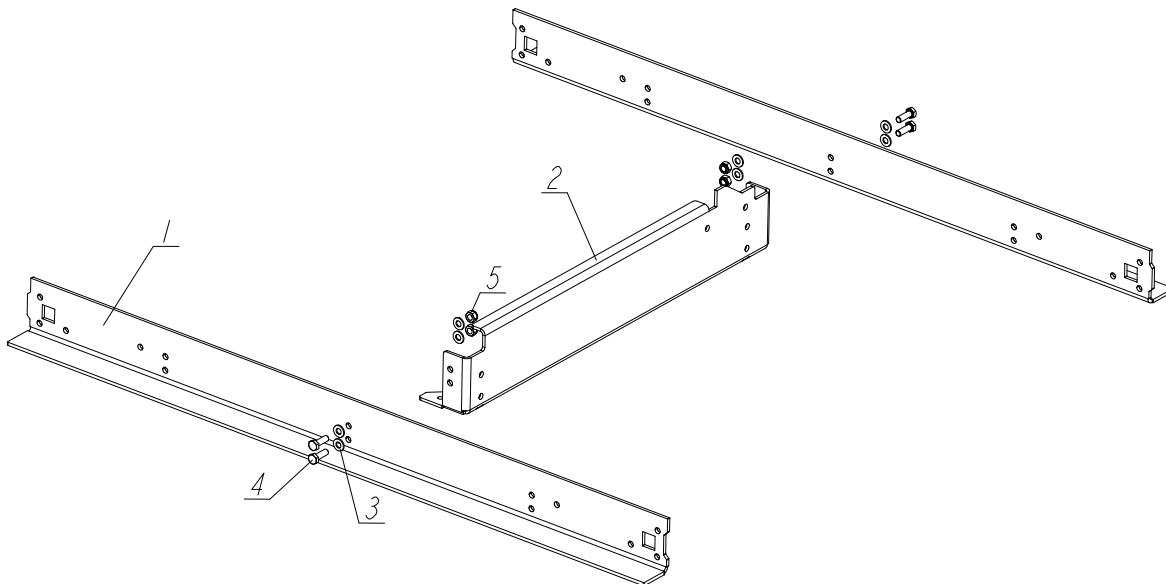

REF	DESCRIPTION (u indicates parts available in assemblies only)	PART #	QTY	
-	SECTION, BED FRAME - COMPLETE	550651	1	
1	RAIL, TRACK	550649-1	2	
2	CROSS BED	586949-1	1	
3	WASHER, 10.5 FLAT ZINC	F81055-1	8	
4	BOLT, DIN933-M10X30-8.8-A2E HEX HEAD	F81003-111	4	
5	NUT, M10-8-B HEX NYLON ZINC LOCK	F81033-1	4	

**2.3 Bed Frame Section (No. 550650)**

550650\_002  
550650

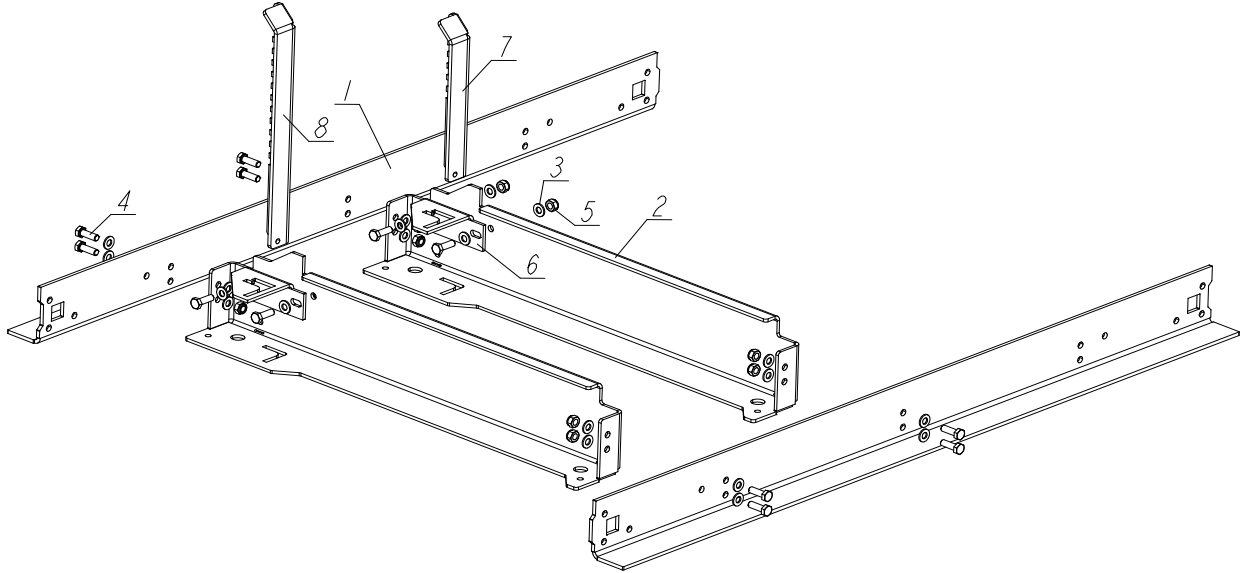

REF	DESCRIPTION (u indicates parts available in assemblies only)	PART #	QTY
-	<b>SECTION, BED FRAME - COMPLETE</b>	550650	1
1	RAIL, TRACK	550649-1	2
2	BED, CROSS	586949-1	2
3	WASHER, 10.5 FLAT ZINC	F81055-1	24
4	BOLT, DIN933-M10X30-8.8-A2E HEX HEAD	F81003-111	12
5	NUT, M10-8-B HEX NYLON ZINC LOCK	F81033-1	12
6	BENT PLATE	X100-1269	2
7	SUPPORT, SIDE - SHORT	T00051-1	1
8	SUPPORT, SIDE	T00041-1	1



## 2.4 Bed Foot (514997)

514997\_001\_A  
514997\_MANUAL

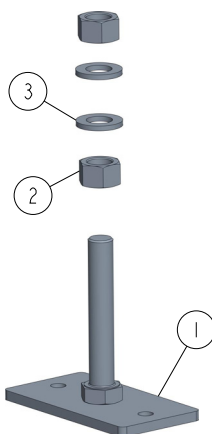

REF.	DESCRIPTION (* indicates parts available in assemblies only)	PART #	QTY	
-	<b>FOOT, LT15P BED - COMPLETE</b>	514997	1	
1	FOOT WELDMENT, LT15 BED ZINC-PLATED	514996-1	1	
2	NUT, M20-8 HEX ZINC	F81037-1	2	
3	WASHER, 21 FLAT ZINC	F81059-2	2	

**2.5 Bed Frame Connection Bracket (No. X100-1271)**

X100-1271\_001\_A  
X100-1271\_MANUAL

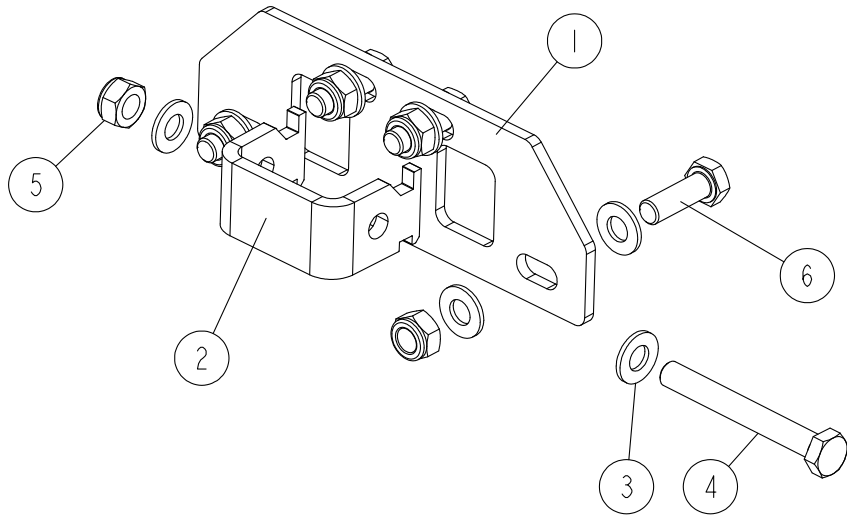

REF.	DESCRIPTION (* indicates parts available in assemblies only)	PART #	QTY
-	<b>BRACKET, BED FRAME CONNECTION</b>	X100-1271	1
1	FLAT PLATE	X100-1272	1
2	BENT PLATE	X100-1273	1
3	WASHER, 10.5 FLAT ZINC	F81055-1	10
4	BOLT, M10X80-8.8 HEX HEAD ZINC	F81003-50	1
5	NUT, M10-8-B HEX NYLON ZINC LOCK	F81033-1	5
6	SCREW, DIN933-M10X30-8.8-A2E HEX CAP FULL THREAD	F81003-111	4

## 2.6 Clamp Assy., LX50SA (No. 586950)

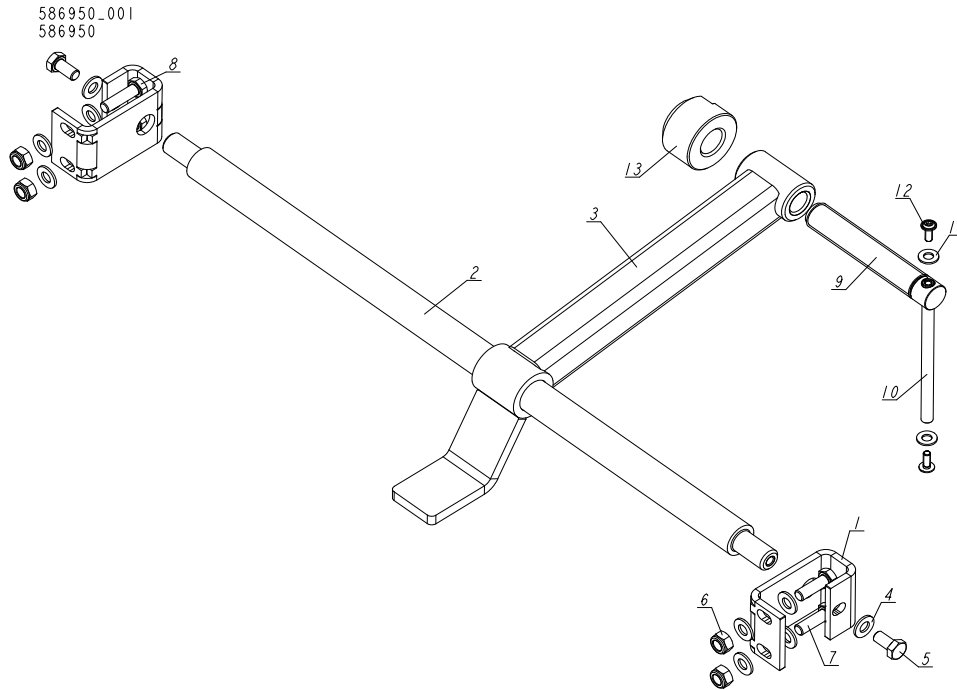

REF	DESCRIPTION (u indicates parts available in assemblies only)	PART #	QTY
-	<b>CLAMP ASSY.</b>	586950	1
1	BRACKET, SIDE SUPPORT MOUNTING, LX50 ZIN	530674-1	2
2	ROD, SIDE SUPPORT MAIN	515059-1	1
3	ARM, CLAMP LX50 ZINC	530701-1	1
4	WASHER, 10.5 FLAT ZINC	F81055-1	10
5	BOLT, ISO 4017-M10X20-8.8-A2E HEX HEAD F	F81003-53	2
6	NUT, M10-8-B HEX NYLON ZINC LOCK	F81033-1	4
7	BOLT, DIN933-M10X30-8.8-A2E HEX HEAD	F81003-111	3
8	BOLT, M10X35-8.8 HEX HEAD FULL THREAD ZI	F81003-17	1
-	ACME CLAMP SCREW, COMPLETE	507563	1
9	SCREW, ACME CLAMP	507463	1
10	ROD, SCREW HANDLE	511923-1	1
11	WASHER, 8.4 FLAT ZINC	F81054-1	2
12	SCREW, M6X16 BN 11252 "BOSSARD" BUTTON H	F81001-24	2
13	CAP, MOUNTING	T00414	1

**2.7 End Stop Assembly (No. X100-1274)**

X100-1274-001  
X100-1274\_MANUAL

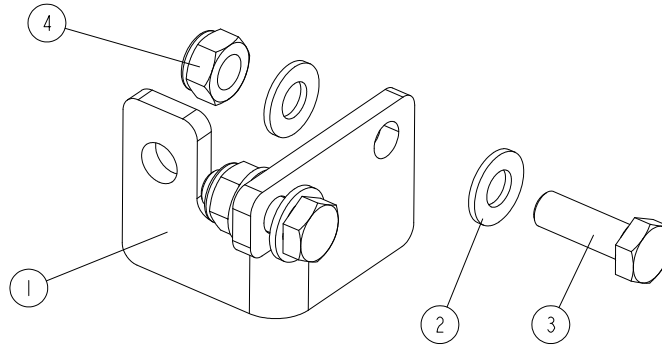

REF.	DESCRIPTION (* indicates parts available in assemblies only)	PART #	QTY
-	<b>STOP ASSEMBLY, END</b>	X100-1274	1
1	BENT PLATE	X100-1275	1
2	WASHER, 10.5 FLAT ZINC	F81055-1	4
3	BOLT, M10X30-8.8 HEX HEAD FULL THREAD ZINC	F81003-2	2
4	NUT, M10-8-B HEX NYLON ZINC LOCK	F81033-1	2

## 2.8 Segment Joining Bracket (No. 550702)

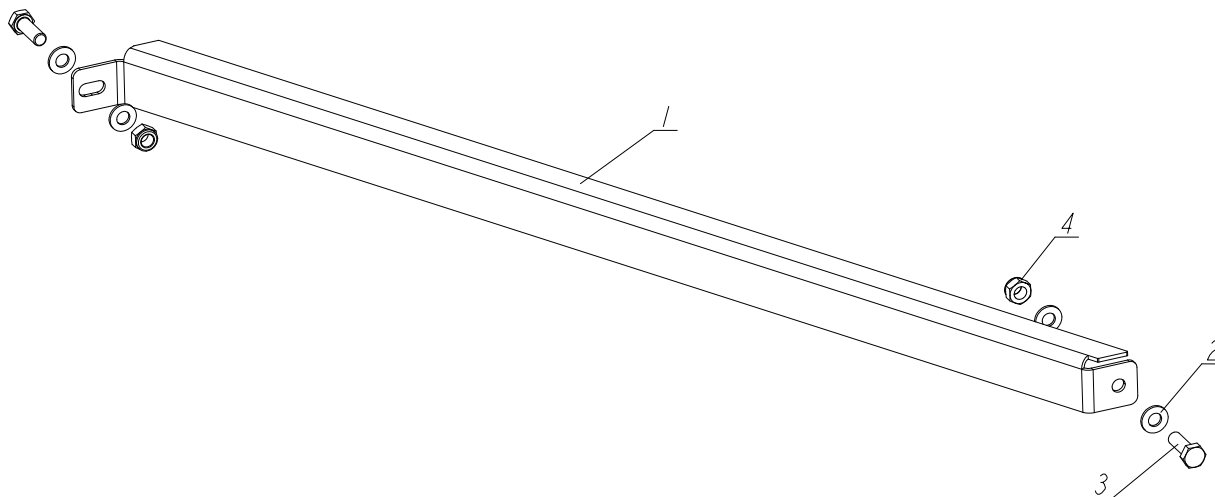
550702-001  
550702

REF.	DESCRIPTION (* indicates parts available in assemblies only)	PART #	QTY	
-	<b>BRACKET, SEGMENT JOINING</b>	550702	1	
1	PLATE, SEGMENT CONNECTION	550701-1	1	
2	WASHER, 10.5 ZINC FLAT	F81055-1	4	
3	BOLT, M10X30-8.8 HEX HEAD FULL THREAD ZINC	F81003-2	2	
4	NUT, M10-8-B HEX NYLON ZINC LOCK	F81033-1	2	

2.9 Bed Frame Extension, LX50 (No. LX50SA-EXT2)

LX50SA-EXT2\_001  
LX50SA-EXT2

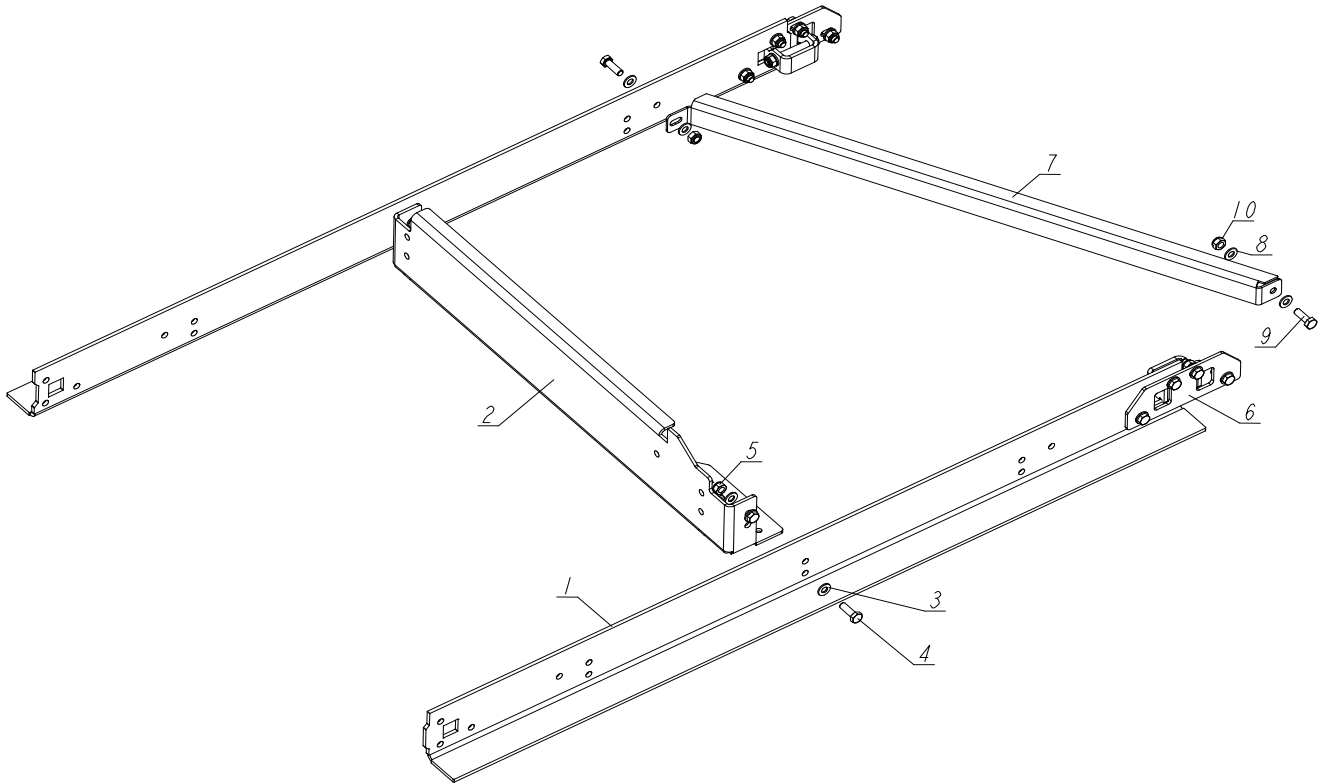

REF	DESCRIPTION (u indicates parts available in assemblies only)	PART #	QTY
-	<b>LX50SA EXTENSION</b>	LX50SA-EXT2	1
-	SECTION, BED FRAME - COMPLETE	550651	1
1	RAIL, TRACK	550649-1	2
2	CROSS BED	586949-1	1
3	WASHER, 10.5 FLAT ZINC	F81055-1	8
4	BOLT, DIN933-M10X30-8.8-A2E HEX HEAD	F81003-111	4
5	NUT, M10-8-B HEX NYLON ZINC LOCK	F81033-1	4
6	ASSY, BED CONNECTION	X100-1271	2
-	BRACKET, SEGMENT JOINING	550702	1
7	PLATE, SEGMENT CONNECTION	550701-1	1
8	WASHER, 10.5 FLAT ZINC	F81055-1	4
9	BOLT, M10X30-8.8 HEX HEAD FULL THREAD ZI	F81003-2	2
10	NUT, M10-8-B HEX NYLON ZINC LOCK	F81033-1	2

## 2.10 Bed Frame Extension w/Side Support (No. LX50SA-EXT-S2)

LX50SA-EXT-S2\_001  
LX50SA-EXT2-S2

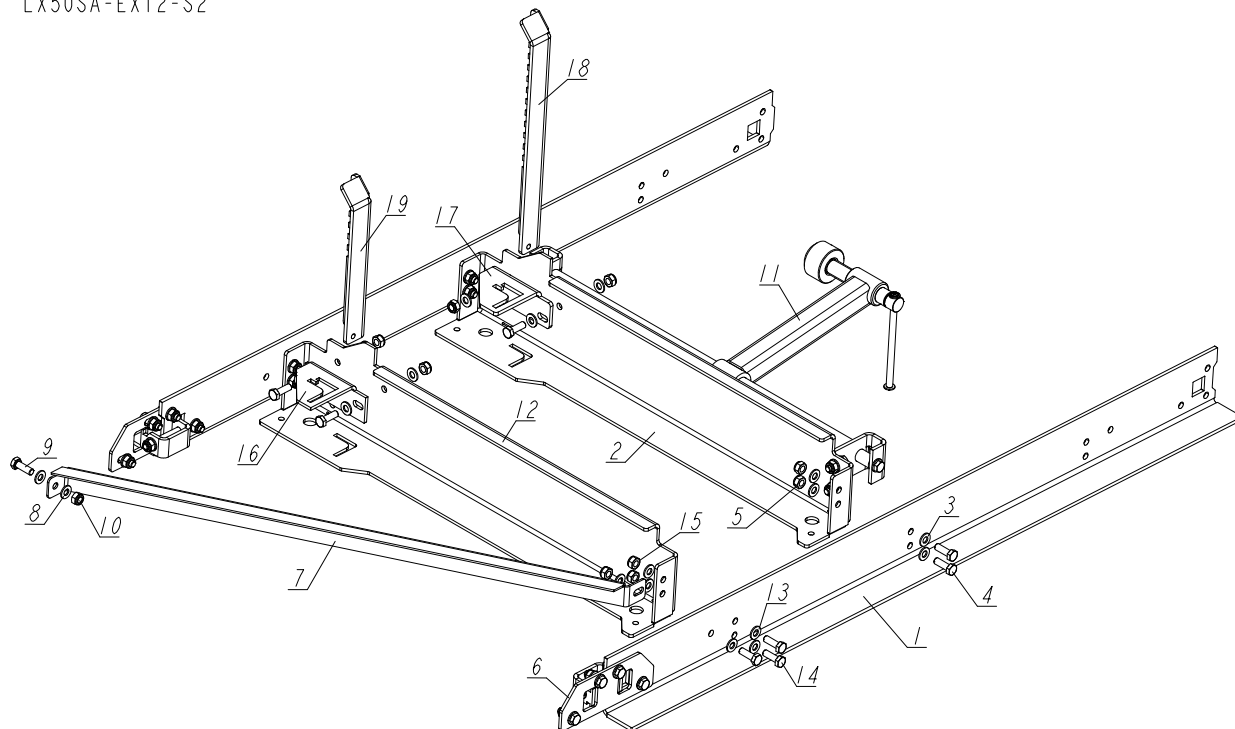

REF	DESCRIPTION (◆ indicates parts available in assemblies only)	PART #	QTY
-	LX50SA EXTENSION W/ SUPPORTS	LX50SA-EXT2-S2	1
-	LX50SA EXTENSION	LX50SA-EXT2	1
-	SECTION, BED FRAME - COMPLETE	550651	1
1	RAIL, TRACK	550649-1	2
2	CROSS BED	586949-1	1
3	WASHER, 10.5 FLAT ZINC	F81055-1	8
4	BOLT, DIN933-M10X30-8.8-A2E HEX HEAD	F81003-111	4
5	NUT, M10-8-B HEX NYLON ZINC LOCK	F81033-1	4
6	ASSY, BED CONNECTION <a href="#">See Section 2.5</a>	X100-1271	2
-	BRACKET, SEGMENT JOINING	550702	1
7	PLATE, SEGMENT CONNECTION	550701-1	1
8	WASHER, 10.5 FLAT ZINC	F81055-1	4
9	BOLT, M10X30-5.8 HEX HEAD FULL THREAD ZI	F81003-2	2
10	NUT, M10-8-B HEX NYLON ZINC LOCK	F81033-1	2
11	CLAMP <a href="#">See Section 2.6</a>	586950	1
12	CROSS BED	557353-1	1
13	WASHER, 10.5 FLAT ZINC	F81055-1	14
14	BOLT, DIN933-M10X30-8.8-A2E HEX HEAD	F81003-111	7
15	NUT, M10-8-B HEX NYLON ZINC LOCK	F81033-1	7
16	BRACKET, SIDE SUPPORT	T00043-1	1
17	BENT PLATE	X100-1269	1
18	SUPPORT, SIDE	T00041-1	1
19	SUPPORT, SIDE - SHORT	T00051-1	1

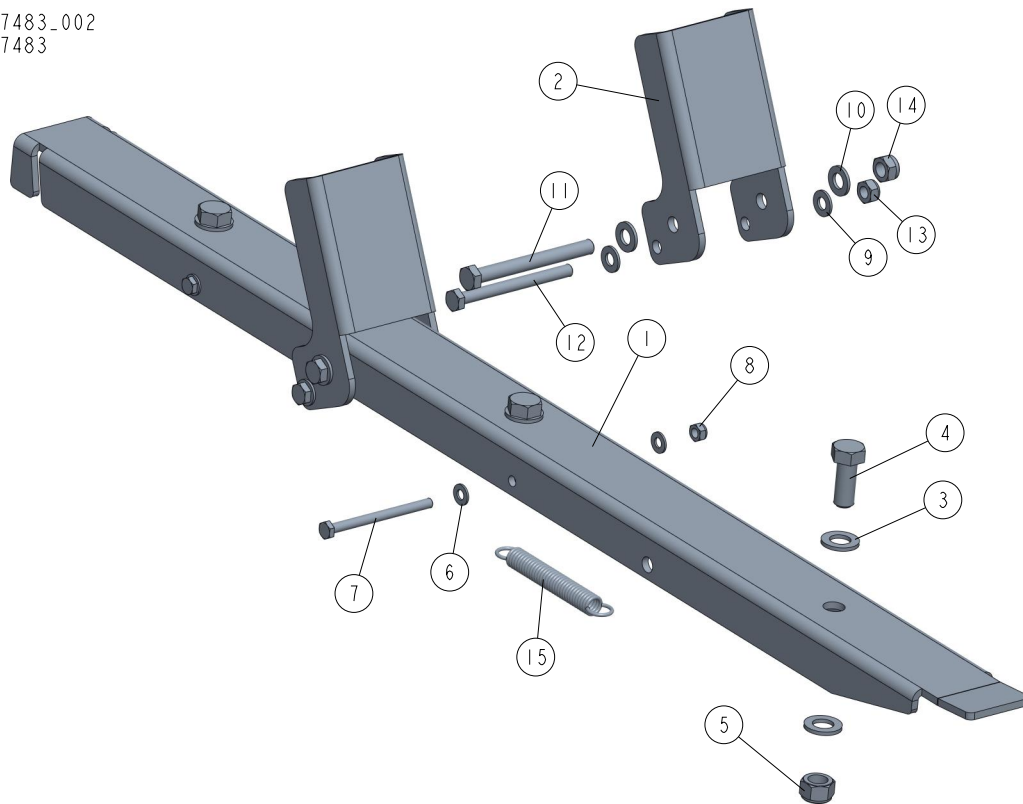
2.11 Loading Ramp Assembly 097483<sup>1</sup>097483\_002  
097483

REF	DESCRIPTION (◆ indicates parts available in assemblies only)	PART #	QTY
-	RAMP ASSEMBLY, LOADING	097483	1
1	PLATE, LT10 LOADING RAMP - MAIN	097481-1	1
2	BRACKET, LOG LOADING STOP	097482-1	2
3	WASHER, 17 SPLIT LOCK ZINC	F81058-1	6
4	BOLT, M16X40-8.8 HEX HEAD FULL THREAD ZI	F81006-13	3
5	NUT, M16-8 HEX NYLON ZINC LOCK	F81036-2	3
6	WASHER, 8,4-FLAT ZINC	F81054-1	4
7	BOLT, M8X100-8.8 HEX HEAD ZINC	F81002-23	2
8	NUT, M8-8-B HEX NYLON ZINC LOCK	F81032-2	2
9	WASHER, 10.5 FLAT ZINC	F81055-1	4
10	WASHER, 13 FLAT ZINC	F81056-1	4
11	BOLT, M12X115-8.8-B HEX HEAD ZINC	F81004-33	2
12	BOLT, M10X110-8.8 HEX HEAD ZINC	F81003-43	2
13	NUT M10 ZC 8 NYLOCK DIN 982 ISO 7040	F81033-1	2
14	NUT, M12-8 HEX NYLON ZINC LOCK	F81034-2	2
15	SPRING, N1.9XN14.2X104	091865	2

1.(2x097483) included in assembly 586967



## 2.12 Log taper wedge X100-1304 (130005 for American market)

X100-1304\_001  
X100-1304

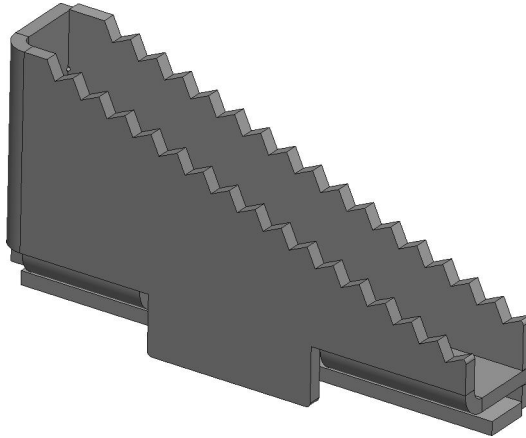

REF	DESCRIPTION (◆ indicates parts available in assemblies only)	PART #	QTY	
-	WLDMT, LOG TAPER	X100-1304	1	
-	WLDMNT, LOG TAPER WEDGE LX25/55 (AMERICAN MARKET ONLY)	130005	1	

## SECTION 3 SAW HEAD

## 3.1 Saw Head (LX50SA, No. 557345)

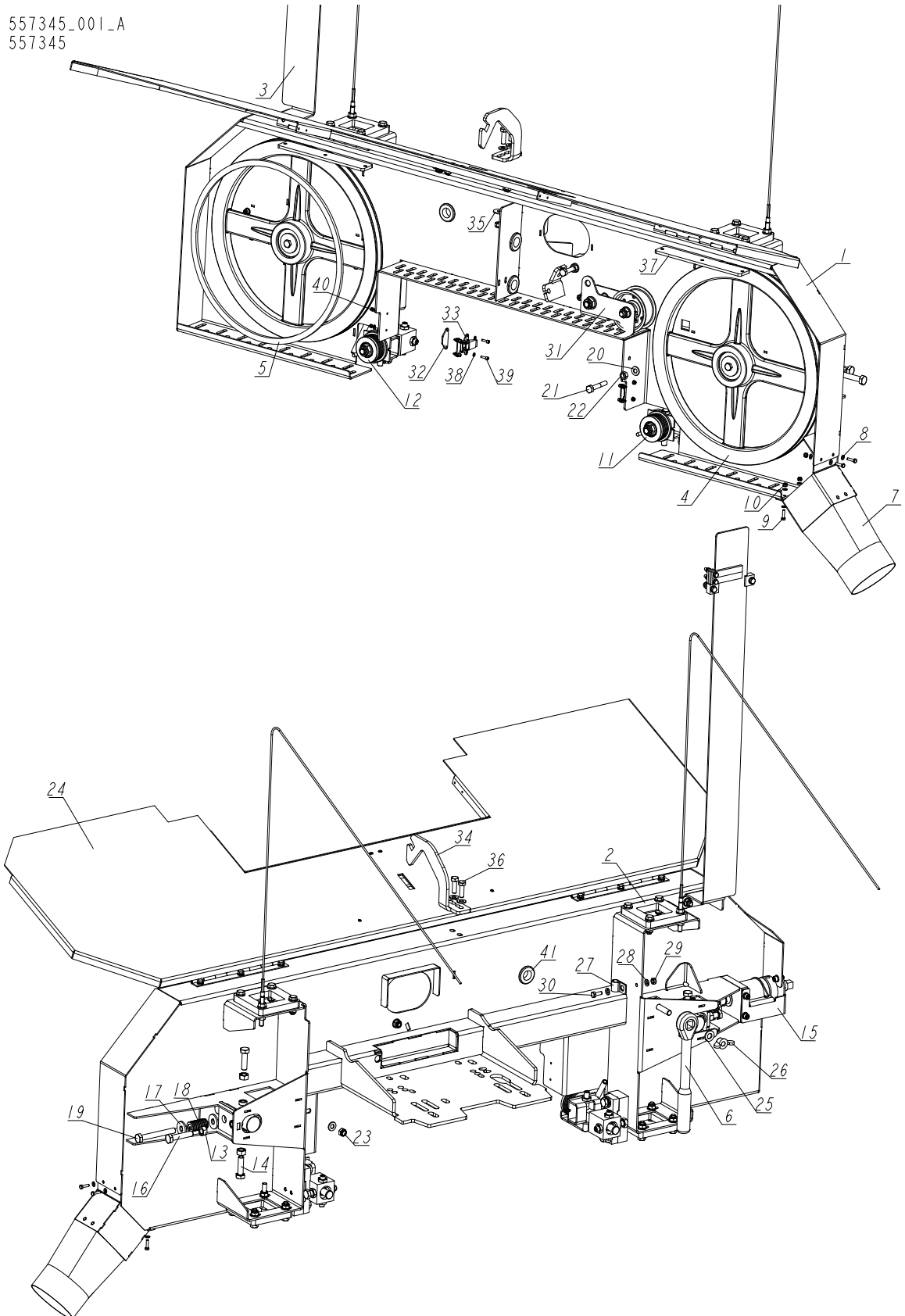

REF	DESCRIPTION (◆ indicates parts available in assemblies only)	PART #	QTY
-	SAW HEAD,LX50SA	557345	1
1	SAW HEAD,LX50SA	557344-1	1
2	SLIDE ASSEMBLY, UP/DOWN <a href="#">See Section 3.3</a>	550699	1
3	SCALE, BLADE HEIGHT - COMPLETE <a href="#">See Section 3.2</a>	530667	1
4	ASSY, BANDWHEEL SHAFT <a href="#">See Section 3.5</a>	X100-961	2
5	BELT, B47.5	X100-900	1
6	WRENCH, LT20 BLADE TENSION	091620	1
7	ASSY, SAWDUST CHUTE	X100-1288	1
8	WASHER, 4.3 FLAT ZINC	F81051-2	8
9	BOLT, M4X16 5.8 HEX HEAD FULL THREAD ZIN	F81011-6	4
10	NUT, M4-B HEX NYLON ZINC LOCK	F81029-1	4
11	BLADE GUIDE ASSEMBLY, DRIVE SIDE	593254	1
12	BLADE GUIDE ASSEMBLY, IDLESIDE	593258	1
13	NUT, M10-8-B-HEX ZINC	F81033-3	3
14	BOLT,M10X35-8.8 HEX HEAD FULL THREAD ZIN	F81003-17	2
15	TENSIONER ASSEMBLY <a href="#">See Section 4.7</a>	X100-1246	1
16	BOLT, M10X50MM,HEX HEAD FULL THREAD ZINC	F81003-4	1
17	WASHER, 10.5 SPECIAL FLAT ZINC	F81055-6	2
18	SPRING, 3/4 O.D.X 1 1/2 DIE	034430	1
19	BOLT, M10X80-8.8 HEX HEAD ZINC	F81003-50	1
20	WASHER, 8.4 FLAT ZINC	F81054-1	6
21	BOLT, M8X50 HH	F81002-10	2
22	NUT, M8-8-B HEX ZINC	F81032-1	2
23	NUT, M8-8-B HEX NYLON ZINC LOCK	F81032-2	4
24	COVER, LX50SA FRONT	557348	1
25	WASHER, 10.5 FLAT ZINC	F81055-1	1
26	NUT, M10 WING	F81033-8	1
27	CLAMP, 1/2" EMT COATED	P07584	1
28	WASHER, 6.4 FLAT ZINC	F81053-1	2
29	NUT, M6-8-B HEX NYLON ZINC LOCK	F81031-2	1
30	BOLT M6X16 HH ZC FT 8.8 DIN 933	F81001-15	1
31	TENSIONER, LX50SA ASSY. <a href="#">See Section 3.8</a>	595710	1
32	WASHER	550822	2
33	HOOK FASTENER, TLE.Z-15/52+R	550743	2
34	FLAT PLATE	X100-1155	1
35	WASHER, 8.5 SPECIAL FLAT ZINC	F81054-11	2
36	BOLT, M8X25-8.8-B HEX HEAD FULL THREAD Z	F81002-5	2
37	PLATE WELDMENT, COVER MOUNT	086701-1	2
38	WASHER, 3.2 FLAT ZINC	F81050-2	16
39	BOLT, M3X12-8.8 FE/ZN PN-EN ISO 4762	F81011-30	8
40	NUT, M3-6-HEX NYLON ZINC LOCK	F81028-2	8
41	GROMMET, RUBBER 3/4 ID	025247	3

## 3.2 Blade Height Scale (No. 530667)

530667\_001\_A  
530667\_MANUAL

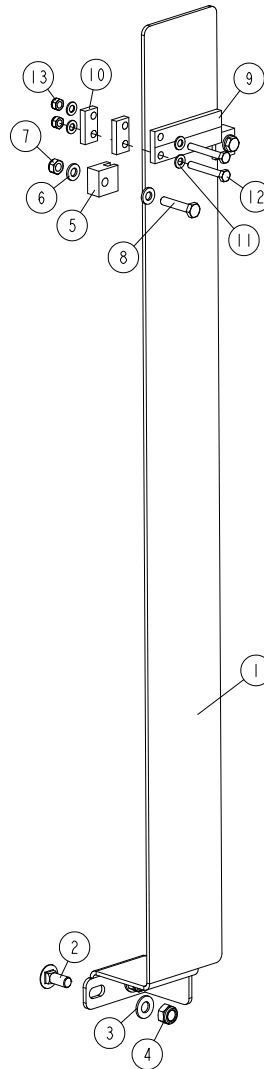

REF.	DESCRIPTION (* indicates parts available in assemblies only)	PART #	QTY
-	<b>SCALE, BLADE HEIGHT - COMPLETE</b>	530667	1
1	PLATE, BLADE HEIGHT SCALE ZINC-PLATED	531993-1	1
2	BOLT, M8X20-8.8 CARRIAGE ZINC	F81002-11	2
3	WASHER, 8.4 FLAT ZINC	F81054-1	2
4	NUT, M8-8-B HEX NYLON ZINC LOCK	F81032-2	2
5	BLOCK, SCALE STIFFENER	X100-1179	2
6	WASHER, 6.4 FLAT ZINC	F81053-1	4
7	NUT, M6-8-B HEX NYLON ZINC LOCK	F81031-2	2
8	BOLT, M6X30-8.8 HEX HEAD FULL THREAD ZINC	F81001-8	2
9	INDICATOR, BLADE HEIGHT SCALE	094821	1
10	SPACER, BLADE HEIGHT SCALE	550707-1	2
11	WASHER, 5.3 FLAT ZINC	F81052-1	4
12	BOLT, M5X35 8.8 HEX HEAD FULL THREAD ZINC	F81000-10	2
13	NUT, M5-8 DIN985 HEX NYLON ZINC LOCK	F81030-2	2

### 3.3 Up/Down Slide (No. 550699)

550699\_001  
550699

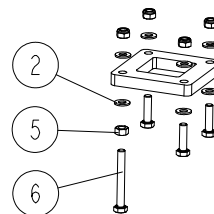
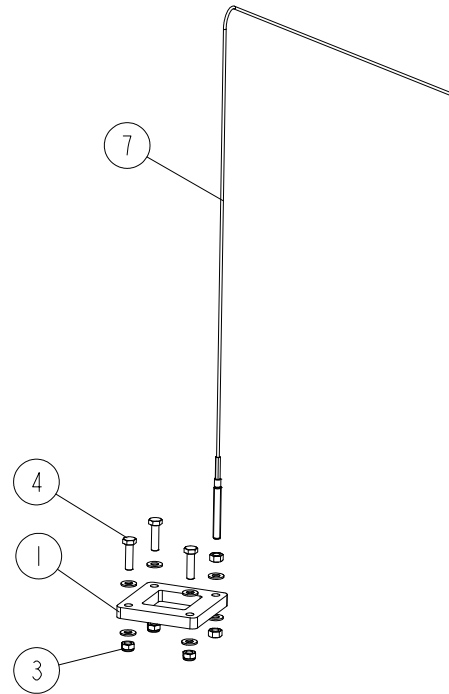
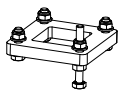
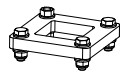
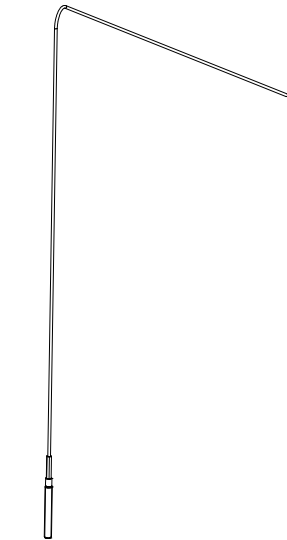

REF.	DESCRIPTION (* indicates parts available in assemblies only)	PART #	QTY
-	<b>SLIDE ASSEMBLY, UP/DOWN</b>	550699	1
1	BLOCK, VERTICAL SLIDE GUIDE	X100-327	4
2	WASHER, 8.4 FLAT ZINC	F81054-1	32
3	NUT, M8-8-B HEX NYLON ZINC LOCK	F81032-2	14
4	BOLT, M8X30 8.8 HEX HEAD FULL THREAD ZINC	F81002-7	12
5	NUT, M8-8-B HEX ZINC	F81032-1	6
6	BOLT, M8X65 8.8 HEX HEAD FULL THREAD ZINC	F81002-9	2
7	ROPE, N3; L-1250; M8 STEEL	550700	2

### 3.4 Cable Guide Roller (No. 550817)

550817\_001  
550817

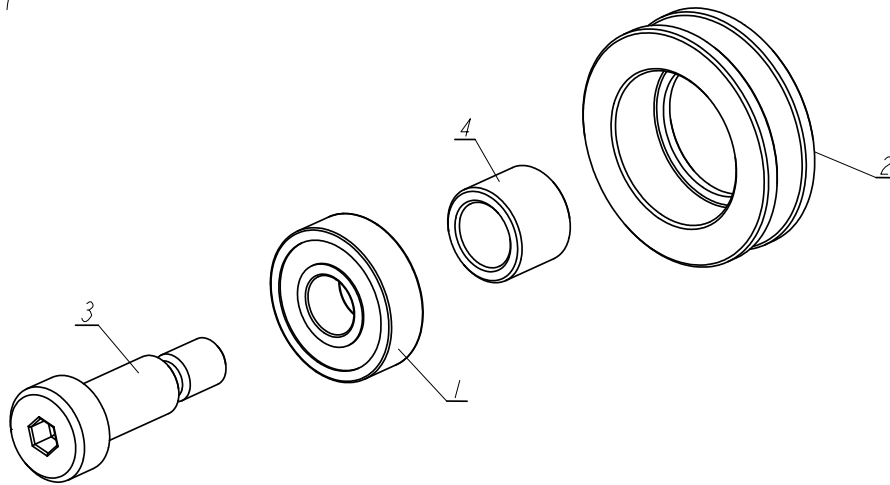

REF.	DESCRIPTION (* indicates parts available in assemblies only)	PART NO.	QTY	
-	<b>ROLLER, CABLE GUIDE</b>	550817	1	
1	BEARING, 6000.2RSR	087471	1	
2	ROLLER	532000	1	
3	BOLT, 10/M8X20-12.9 BOSSARD SHOULDER	F81003-99	1	
4	BUSHING, 11/16-12.5 SPACER	550818-1	1	

### 3.5 Wheel Assembly (No. X100-961)

X100-961\_011  
X100-961\_MANUAL

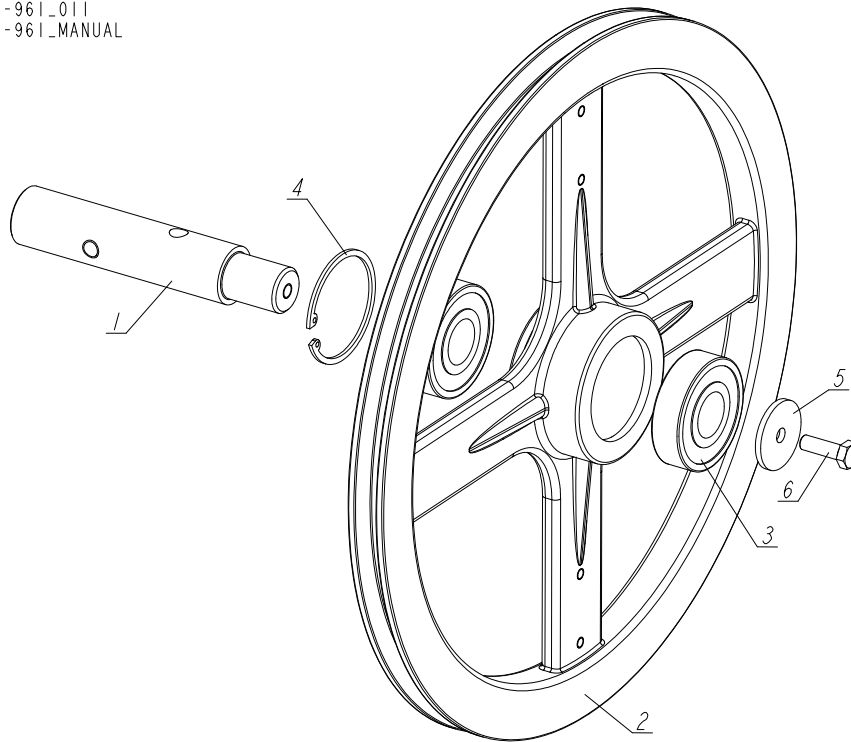

REF	DESCRIPTION (u indicates parts available in assemblies only)	PART #	QTY	
-	<b>Assy, Bandwheel Shaft</b>	X100-961	1	
1	SPINDLE, BLADE WHEEL	X100-301	1	
2	SHEAVE, BANDWHEEL, 15 3/8 OD	X100-303	1	
3	BEARING, .9843X2.4409X.6693	P08066	2	
4	RING, 2 7/16" BEVELLED SNAP	F04254-21	1	
5	WASHER, .313X1.5X.125	S08220	1	
6	BOLT, M8X25-8.8-B HEX HEAD FULL THREAD Z	F81002-5	1	



### 3.6 Blade Guide Assembly, Drive Side (No, 593254)

593254\_001  
593254

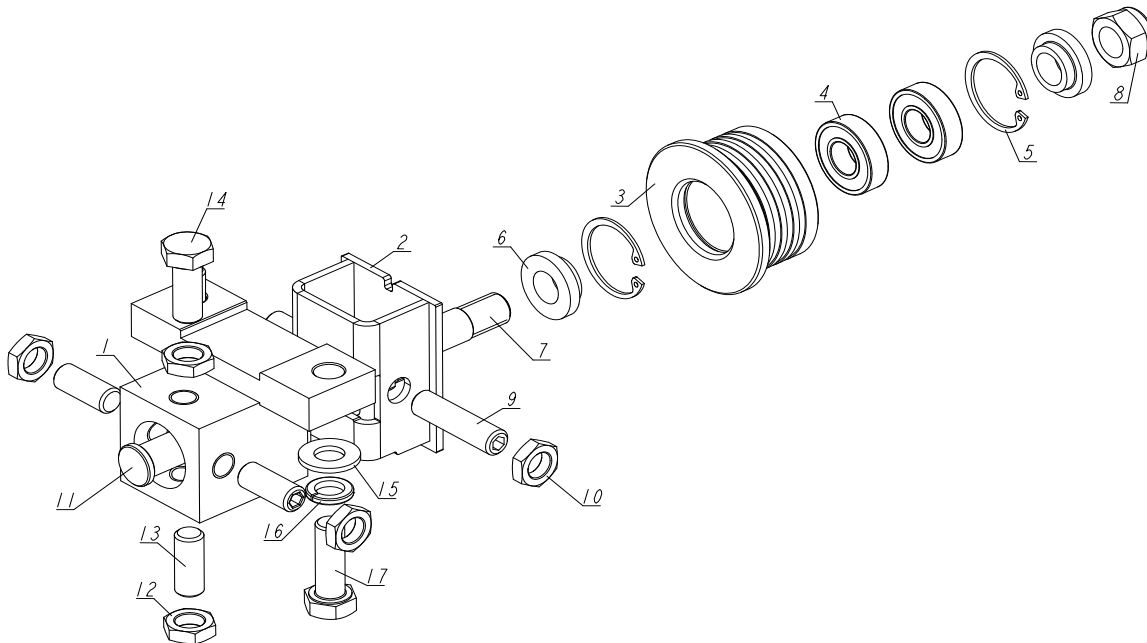

REF	DESCRIPTION (u indicates parts available in assemblies only)	PART #	QTY
-	<b>BLADE GUIDE ASSEMBLY, DRIVE SIDE</b>	593254	1
1	BLOCK WELDMENT, BLADE GUIDE MOUNT	087744-1	1
-	BLADE GUIDE ASSEMBLY, DRIVE SIDE	593253	1
2	BRACKET WELDMENT, BLADE GUIDE ROLLER ZINC-PLATED	593251-1	1
-	ROLLER, BLADE GUIDE W/BEARINGS	593250	1
-	ROLLER ASSY, BLADE GUIDE - PL	A09678-1	1
3	ROLLER, BLADE GUIDE NARROW	586175	1
4	BEARING, ABEG R8-2RS (12,7X28,575X7,9)	586174	2
5	RING, W29 WG PN/M-85111 INSIDE RETAINING	F81090-90	2
6	BUSHING, 12.7/25-8.2	593249-1	2
7	AXLE, LX50 BLADE GUIDE ROLLER	593248-1	1
8	NUT, M12 8 HEX NYLON ZINC LOCK	F81034-2	1
9	SCREW, M10X1X40 DIN 913 A2-70 STAINLESS	F81015-2	2
10	NUT, M10X1-04-ST-A2 ISO 8675 THIN	F81033-10	2
11	SHAFT, BLADE GUIDE MOUNT ZINC-PLATED	503588-1	1
12	NUT, M10X1-04-ST-A2 ISO 8675 THIN	F81033-10	4
13	SCREW, M10X1X25 DIN 913 STAINLESS STEEL	F81015-4	3
14	BOLT, M10X1X25 DIN 933 STAINLESS STEEL	F81003-28	1
15	WASHER, 10.5 FLAT ZINC	F81055-1	2
16	WASHER, Z 10.2 SPLIT LOCK ZINC	F81055-2	2
17	BOLT, DIN933-M10X30-8.8-A2E HEX HEAD	F81003-111	2

## 3.7 Blade Guide Assembly, Idle Side (No. 593258)

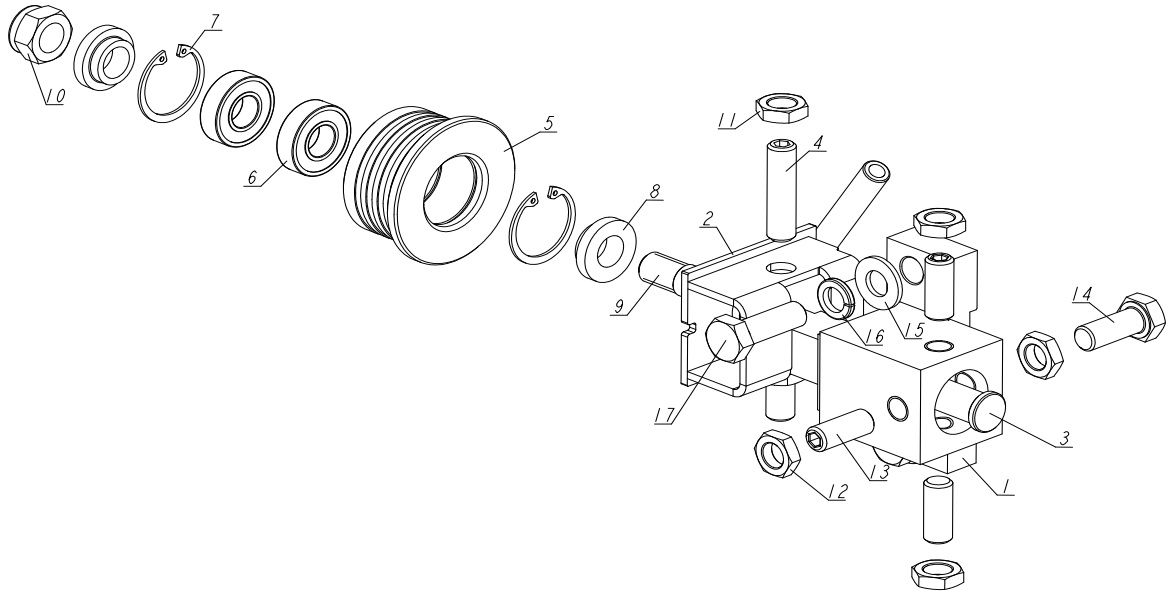
593258\_001  
593258

REF	DESCRIPTION (u indicates parts available in assemblies only)	PART #	QTY
-	<b>BLADE GUIDE ASSEMBLY, IDLESIDE</b>	593258	1
1	BLOCK WELDMENT, BLADE GUIDE MOUNT	087744-1	1
-	BLADE GUIDE ASSEMBLY, IDLE SIDE	593257	1
2	BRACKET WELDMENT, BLADE GUIDE ROLLER ZINC-PLATED	593255-1	1
3	SHAFT, BLADE GUIDE MOUNT ZINC-PLATED	503588-1	1
4	SCREW, M10X1X40 DIN 913 A2-70 STAINLESS	F81015-2	2
-	ROLLER, BLADE GUIDE W/BEARINGS	593250	1
-	ROLLER ASSY, BLADE GUIDE - PL	A09678-1	1
5	ROLLER, BLADE GUIDE NARROW	586175	1
6	BEARING, ABEG R8-2RS (12,7X28,575X7,9)	586174	2
7	RING, W29 WG PN/M-85111 INSIDE RETAINING.	F81090-90	2
8	BUSHING, 12.7/25-8.2	593249-1	2
9	AXLE, LX50 BLADE GUIDE ROLLER	593248-1	1
10	NUT, M12 8 HEX NYLON ZINC LOCK	F81034-2	1
11	NUT, M10X1-04-ST-A2 ISO 8675 THIN	F81033-10	2
12	NUT, M10X1-04-ST-A2 ISO 8675 THIN	F81033-10	4
13	SCREW, M10X1X25 DIN 913 STAINLESS STEEL	F81015-4	3
14	BOLT, M10X1X25 DIN 933 STAINLESS STEEL	F81003-28	1
15	WASHER, 10.5 FLAT ZINC	F81055-1	2
16	WASHER, Z 10.2 SPLIT LOCK ZINC	F81055-2	2
17	BOLT, DIN933-M10X30-8.8-A2E HEX HEAD	F81003-111	2

### 3.8 Tensioner Assembly (595710)

595710\_001\_B  
595710

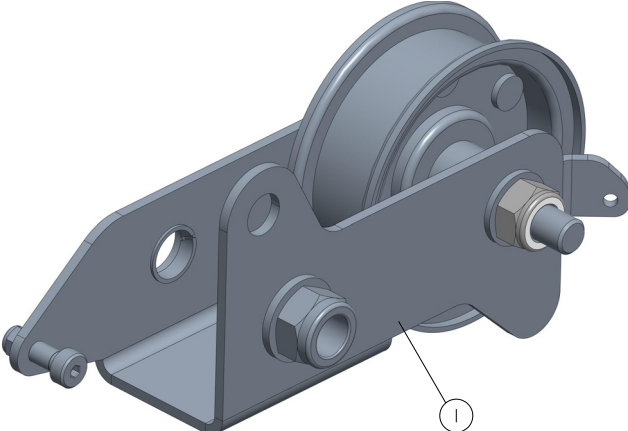

REF	DESCRIPTION (u indicates parts available in assemblies only)	PART #	QTY	
1	TENSIONER, LX50SA ASSY.	595710	1	

**SECTION 4 SAWMILL MAST**

### 4.1 Sawmill Mast, LX50SA (No. 594395)

594395\_001  
594395

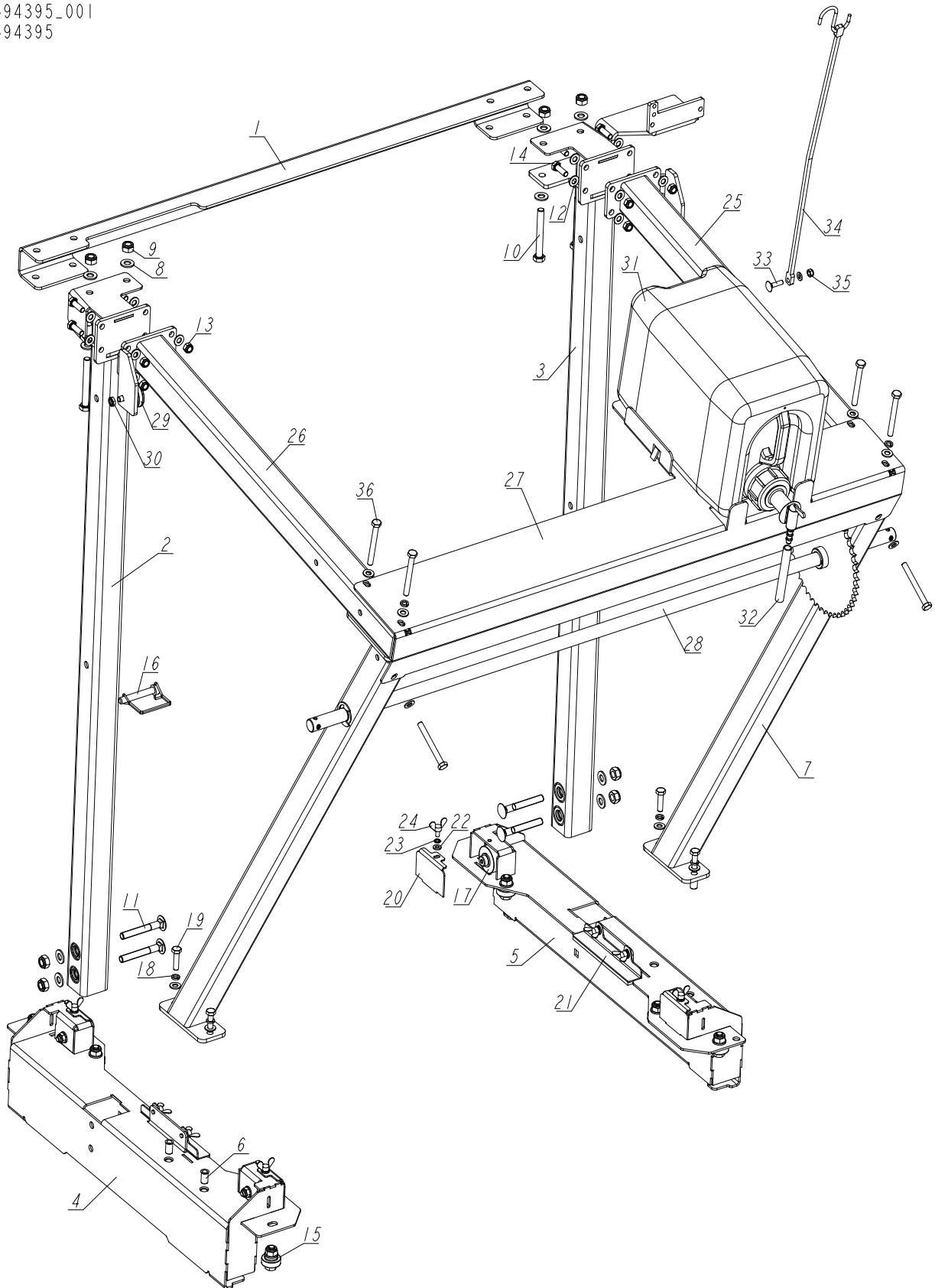

**SAWMILL MAST**

Sawmill Mast, LX50SA (No. 594395)

REF	DESCRIPTION (u indicates parts available in assemblies only)	PART #	QTY	
-	<b>MAST, LX50 SAWMILL.</b>	594395	1	
1	ANGLE, LX50SA MAST CONNECTION	550819-1	1	
2	LEG, LEFT FRONT	595712-1	1	
3	LEG, RIGHT FRONT	594397-1	1	
4	WELDMENT, LOWER CARRIAGE MEMBER - LEFT	X100-1123	1	
	WELDMENT, LOWER CARRIAGE LEFT (AMERICAN MARKET ONLY)	X100-1123_US	1	
5	WELDMENT, LOWER CARRIAGE MEMBER - RIGHT	X100-1129	1	
	WELDMENT, LOWER CARRIAGE RIGHT (AMERICAN MARKET ONLY)	X100-1129_US	1	
6	NUT, M8 2.0-4.5 RIVET	F81032-10	4	
7	LEG, MAST	550657-1	2	
8	WASHER, 10.5 FLAT ZINC	F81055-1	12	
9	NUT, M10-8-B HEX NYLON ZINC LOCK	F81033-1	8	
10	BOLT, M10 X 80 -8.8- FE/ZN5 HEX HEAD	F81003-50	4	
11	BOLT, M10X75-8.8 CARRIAGE ZINC	F81003-107	4	
12	WASHER, 8.4 FLAT ZINC	F81054-1	30	
13	NUT, M8-8-B HEX NYLON ZINC LOCK	F81032-2	12	
14	BOLT, M8X25-8.8-B HEX HEAD FULL THREAD Z	F81002-5	8	
15	BEARING ASSEMBLY, HORIZONTAL <a href="#">See Section 4.2</a>	X100-1135	8	
16	PIN, 3/8X2 1/4 SNAP	014151	1	
17	ASSY, CARRIAGE WHEEL <a href="#">See Section 4.3</a>	X100-1136	4	
18	WASHER 8,2 SPLIT LOCK ZINC	F81054-4	6	
19	BOLT, M8 X 30-8.8-B HEX HEAD FULL THREAD	F81002-7	4	
20	BENT PLATE	X100-1139	4	
21	SWEEPER ASSEMBLY <a href="#">See Section 4.4</a>	X100-1260	2	
22	WASHER, 6.4 FLAT ZINC	F81053-1	5	
23	WASHER, Z 6.1 SPLIT LOCK	F81053-3	4	
24	SCREW, M6X10 DIN-316/BN-276 ZINC-PL. WIN	F81001-49	4	
25	BEAM, MAST	550696-1	1	
26	BEAM, MAST LEFT	550697-1	1	
27	PLATE, LX50SA MAST CONNECTION	595713-1	1	
28	SHAFT, COMPLETE UP/DOWN <a href="#">See Section 4.8</a>	550693	1	
29	ROLLER, LIFT CABLE GUIDE	550817	2	
30	NUT, M8-04-FE/ZN ISO4035 HEX THIN	F81032-8	2	
31	BOTTLE, 10L WATER EURO-WIN <a href="#">See Section 4.10</a>	550744	1	
32	TUBING, WATER LUBE 3/8" I.D.	R01885	1	
33	BOLT, M6X25-8.8 ZINC	F81001-20	1	
34	STRAP, 15 RUBBER W/S HOOKS	P07461	1	
35	NUT, M6-8-B HEX NYLON ZINC LOCK	F81031-2	1	
36	BOLT, M8 X 75 8.8 HEX HEAD ZINC	F81002-91	6	

## 4.2 Horizontal Bearing Assembly (Option) (No. X100-1135)

X100-1135\_001  
X100-1135\_MANUAL

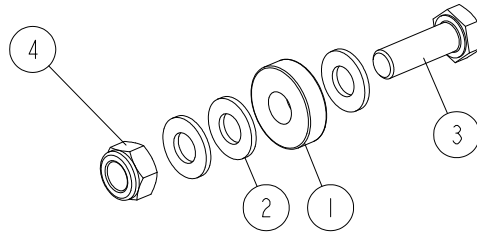

REF.	DESCRIPTION (* indicates parts available in assemblies only)	PART #	QTY	
-	<b>BEARING ASSEMBLY, HORIZONTAL</b>	X100-1135	1	
1	BEARING, LLU 6200	X200-903	1	
2	WASHER, 10.5 FLAT ZINC	F81055-1	3	
3	BOLT, M10X30-8.8 HEX HEAD FULL THREAD ZINC	F81003-2	1	
4	NUT, M10-8-B HEX NYLON ZINC LOCK	F81033-1	1	

**4.3 Assy, Carriage Wheel (No. X100-1136)**

X100-1136\_001  
X100-1136\_MANUAL

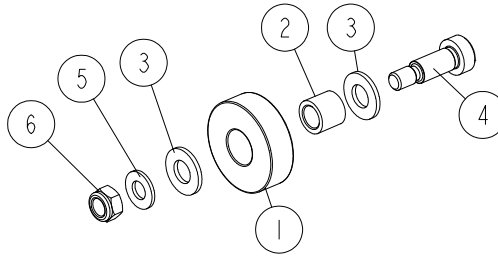

REF.	DESCRIPTION (* indicates parts available in assemblies only)	PART #	QTY
-	<b>ASSY, CARRIAGE WHEEL</b>	X100-1136	1
1	BEARING, LLU 6302	X200-957	1
2	BUSHING, 10/15-13	X100-1138	1
3	WASHER, 10.5 FLAT ZINC	F81055-1	2
4	BOLT, 10/M8X20-12.9 BOSSARD SHOULDER	F81003-99	1
5	WASHER, 8.4 FLAT ZINC	F81054-1	1
6	NUT, M8-8-B HEX NYLON ZINC LOCK	F81032-2	1



#### 4.4 Sweeper Assembly (No. X100-1260)

X100-1260\_001  
X100-1260\_MANUAL

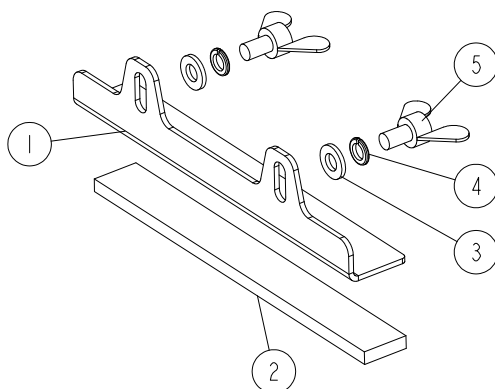

REF.	DESCRIPTION (* indicates parts available in assemblies only)	PART #	QTY	
-	<b>SWEEPER ASSEMBLY</b>	X100-1260	1	
1	BENT PLATE	X100-1261	1	
2	FELT, 5 MM THK TECHNICAL	X100-1262	1	
3	WASHER, 6.4 FLAT ZINC	F81053-1	2	
4	WASHER, Z 6.1 SPLIT LOCK ZINC	F81053-3	2	
5	SCREW, M6X10 DIN-316/BN-276 ZINC-PL. WING	F81001-49	2	

### 4.5 Additional Equipment - Left (No. 550419-S)

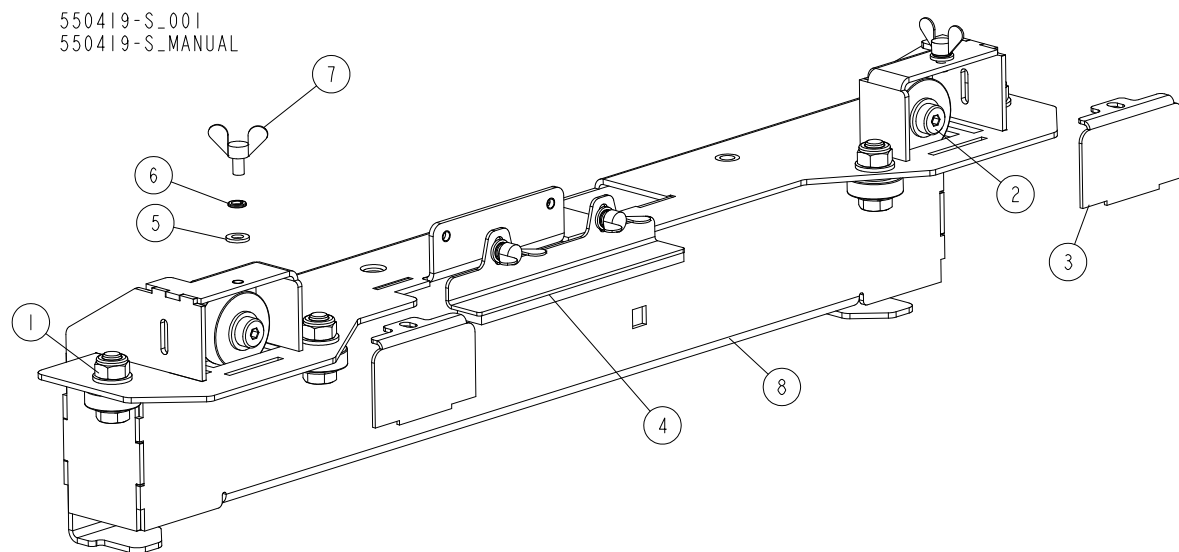

REF.	DESCRIPTION (* indicates parts available in assemblies only)	PART #	QTY
-	<b>EQUIPMENT, LX50 ADDITIONAL LEFT</b>	550419-S	1
1	BEARING ASSEMBLY, HORIZONTAL	X100-1135	4
2	ASSY, CARRIAGE WHEEL	X100-1136	2
3	BENT PLATE	X100-1139	2
4	SWEEPER ASSEMBLY	X100-1260	1
5	WASHER, 6.4 FLAT ZINC	F81053-1	2
6	WASHER, Z 6.1 SPLIT LOCK ZINC	F81053-3	2
7	SCREW, M6X10 DIN-316/BN-276 ZINC-PL. WING	F81001-49	2
8	WELDMENT, LOWER CARRIAGE MEMBER - LEFT	X100-1123	1

## 4.6 Additional Equipment - Right

550512-S\_001  
550512-S\_MANUAL

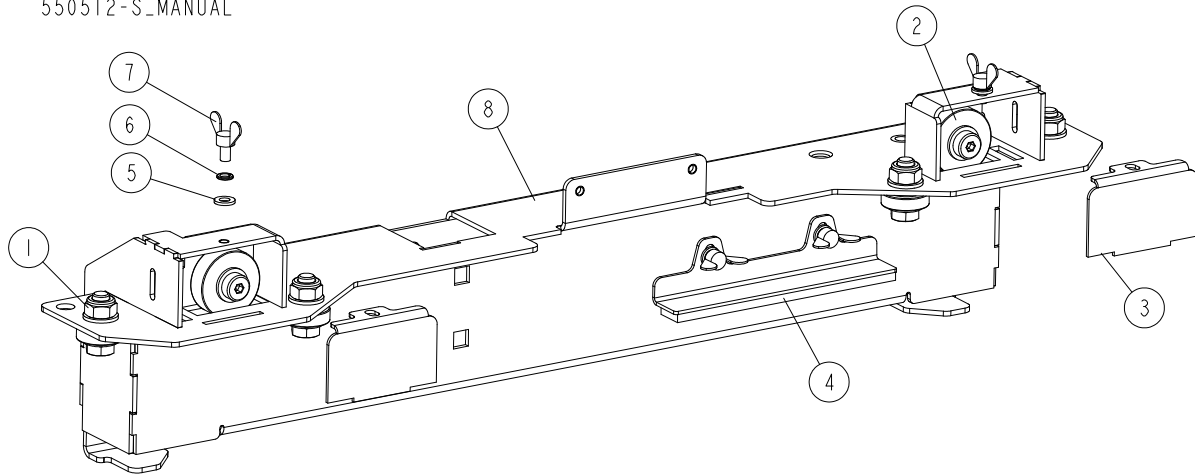

REF.	DESCRIPTION (* indicates parts available in assemblies only)	PART #	QTY
-	<b>EQUIPMENT, LX50 ADDITIONAL RIGHT</b>	550512-S	1
1	BEARING ASSEMBLY, HORIZONTAL	X100-1135	4
2	ASSY, CARRIAGE WHEEL	X100-1136	2
3	BENT PLATE	X100-1139	2
4	SWEEPER ASSEMBLY	X100-1260	1
5	WASHER, 6.4 FLAT ZINC	F81053-1	2
6	WASHER, Z 6.1 SPLIT LOCK ZINC	F81053-3	2
7	SCREW, M6X10 DIN-316/BN-276 ZINC-PL. WING	F81001-49	2
8	WELDMENT, LOWER CARRIAGE MEMBER - RIGHT	X100-1129	1

### 4.7 Tensioner Assembly (No. X100-1246)

X100-1246\_001  
X100-1246\_MANUAL

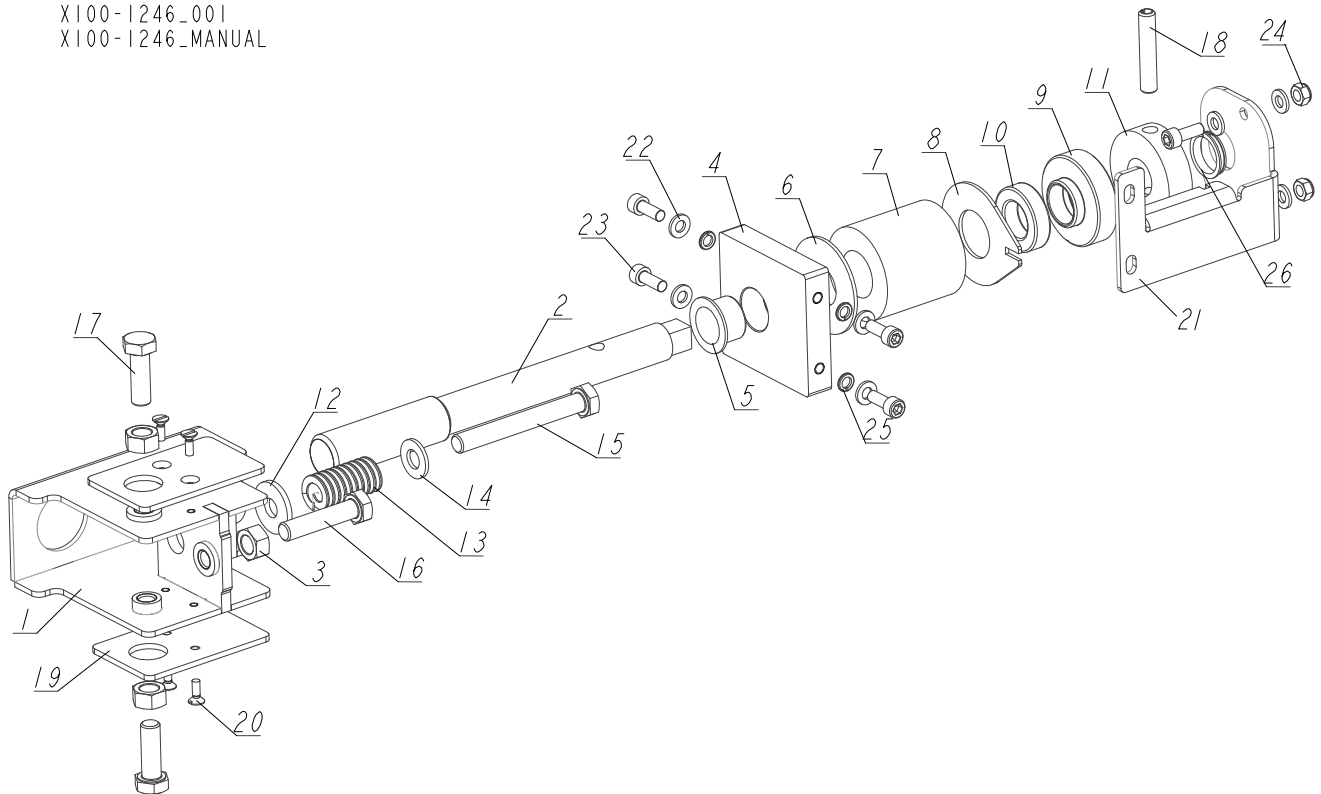

REF.	DESCRIPTION (* indicates parts available in assemblies only)	PART #	QTY
-	<b>TENSIONER ASSEMBLY</b>	X100-1246	1
1	TENSIONER WELDMENT	X100-1239	1
2	TENSIONER ROD	X100-1252	1
3	NUT, M10 8 HEX ZINC	F81033-3	3
4	TENSIONER BLOCK	X100-1247	1
5	BUSHING, IGUS GFM-2023-16	X100-1256	1
6	WASHER, 52X21-2	X100-1284	1
7	SPRING, LT15 BLADE TENSIONER	014828	1
8	FLAT PLATE	X100-1251	1
9	BEARING BUSHING	X100-1248	1
10	BEARING, 51104 CX BALL THRUST	511979	1
11	BUSHING, 16.1/50-15	X100-1250	1
12	WASHER, 10.5 SPECIAL FLAT ZINC	F81055-6	1
13	SPRING, 3/4 O.D.X 1 1/2 DIE	034430	1
14	WASHER, 10.5 FLAT ZINC	F81055-1	1
15	BOLT, M10X80-8.8 HEX HEAD ZINC	F81003-50	1
16	BOLT, M10X45 HEX HEAD FULL THREAD ZINC	F81003-3	1
17	BOLT, M10X30-8.8 HEX HEAD FULL THREAD ZINC	F81003-2	2
18	PIN, 8X45 ROLL ZINC	F81046-6	1
19	POLYETHYLENE PLATE	X100-1249	2
20	SCREW, M4X12 5.8-B SLOTTED COUNTERSUNK HEAD ZINC	F81011-41	4
21	BENT PLATE	X100-1253	1
22	WASHER, 6.4 FLAT ZINC	F81053-1	8

REF.	DESCRIPTION (* indicates parts available in assemblies only)	PART #	QTY	
23	SCREW, M6X16 8.8 HEX SOCKET HEAD CAP ZINC	F81001-21	6	
24	NUT, M6-8-B HEX NYLON ZINC LOCK	F81031-2	2	
25	WASHER, Z 6.1 SPLIT LOCK ZINC	F81053-3	4	
26	BEARING, MCM-20-03 CLIP	X100-1259	1	

### 4.8 Complete Up/Down Shaft (No. 550693)

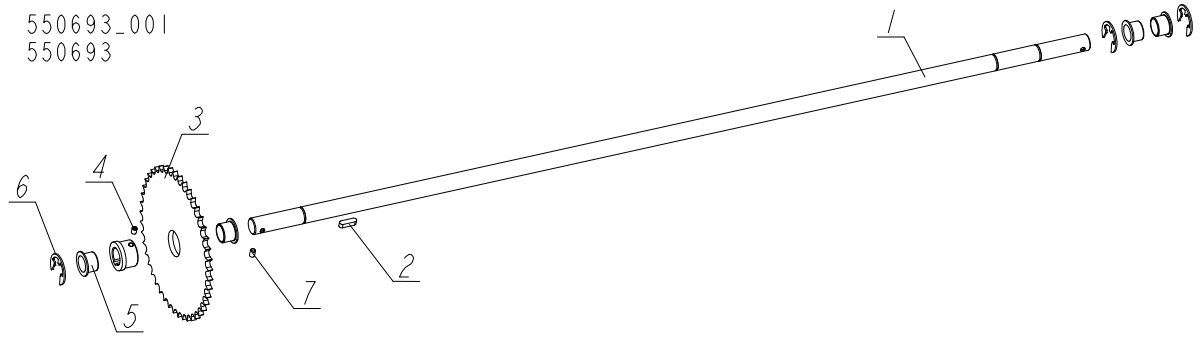

REF.	DESCRIPTION (* indicates parts available in assemblies only)	PART #	QTY	
-	<b>SHAFT, COMPLETE UP/DOWN</b>	550693	1	
1	SHAFT	550655-1	1	
2	KEY, A 6X6X22 PARALLEL	519161	1	
3	SPROCKET ASSEMBLY, LARGE	532323-1	1	
4	SCREW, M6X8-45H HEX SOCKET SET W/FLAT POINT	F81013-1	1	
5	BUSHING, IGUS GFM-2023-16	X100-1256	4	
6	WASHER, 19 DIN6799/PN-85112 RETAINING	F81090-82	3	
7	SCREW, M6X10-45H HEX SOCKET SET FLAT POINT ZINC	F81001-26	2	

## 4.9 Winch Crank Handle, LX50 SA

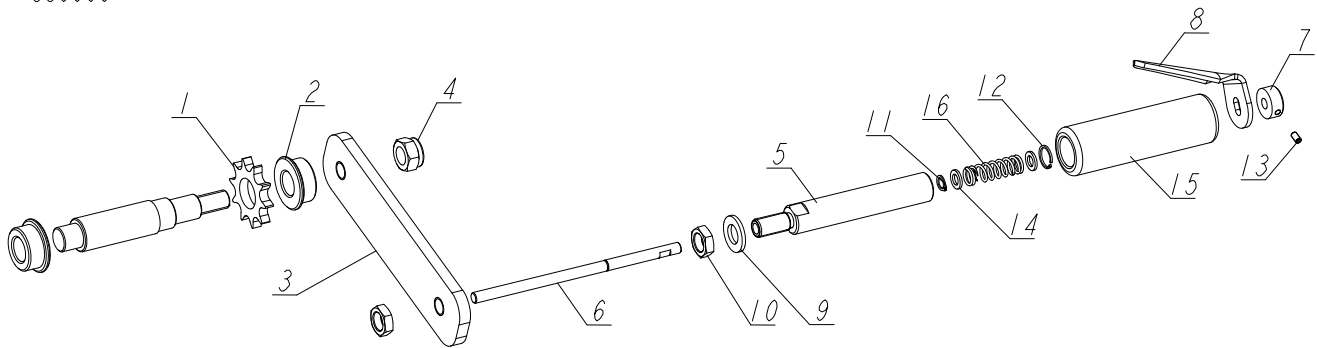
550690\_001  
550690

REF.	DESCRIPTION (* indicates parts available in assemblies only)	PART #	QTY
-	<b>HANDLE, WINCH CRANK</b>	550690	1
1	SPROCKET, SMALL	550689-1	1
2	BUSHING, SLIDE	532333	2
3	PLATE, CRANK HANDLE	531997-1	1
4	NUT, M12-8 DIN 982 HEX NYLON ZINC LOCK	F81034-2	1
-	HANDLE, CUTTING WIDTH SETTING	096499	1
5	MANDREL, CRANK HANDLE	096504-1	1
6	PIN, CRANK HANDLE	097095-1	1
7	RING, 7 STOPPING LIGHT TYPE	F81039-9	1
8	PLATE, LX50	587015-1	1
9	WASHER, 13 FLAT ZINC	F81056-1	1
10	NUT, M12-04-A THIN ZINC	F81034-6	2
11	RING, Z7 OUTSIDE RETAINING	F81090-17	1
12	RING, W13 INSIDE RETAINING	F81090-18	1
13	SCREW, M4X8 GEOMET HEX SOCKET SET W/FLAT POINT	F81011-40	1
14	WASHER, 7.2/12.5	097264	2
15	TUBE, HANDLE	097263	1
16	SPRING, 0.48DIA X 1.5 LONG SS COMPRESSION	047690	1

**4.10 Water Bottle, 10l (No. 550744)**

550744\_001  
550744

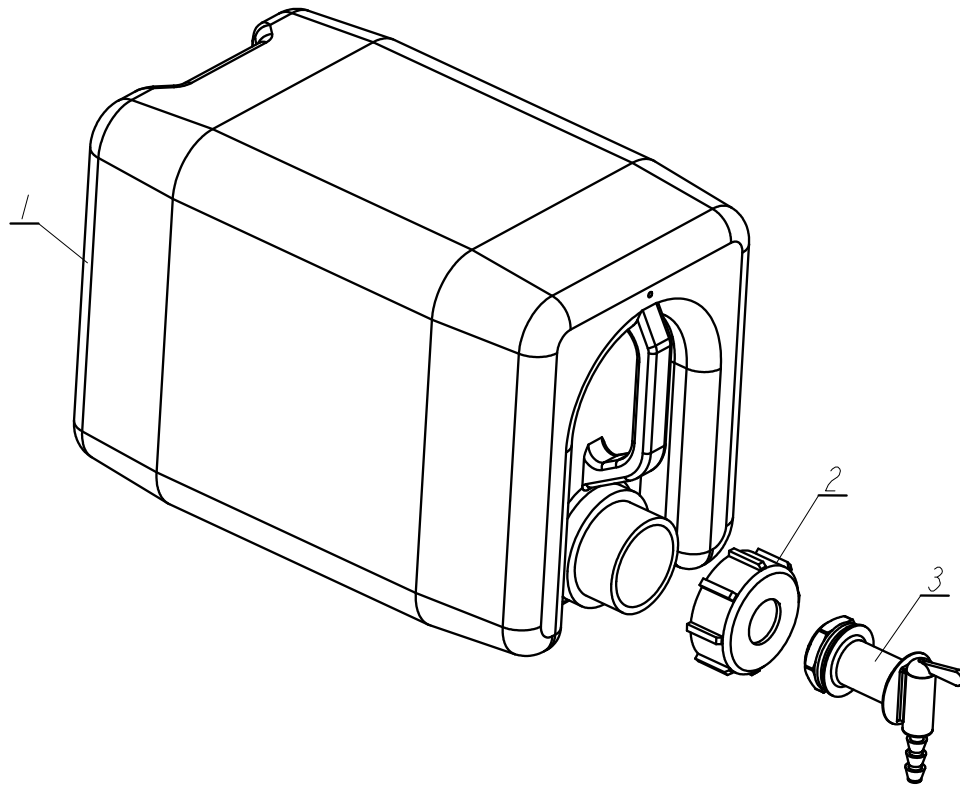

REF.	DESCRIPTION (* indicates parts available in assemblies only)	PART #	QTY
-	<b>BOTTLE, 10L WATER EURO-WIN</b>	550744	1
1	TANK, OIL (10L)	711400	1
2	CAP, WATER BOTTLE	513867	1
3	TAP, EURO-WIN BOTTLE DRAIN	550745	1

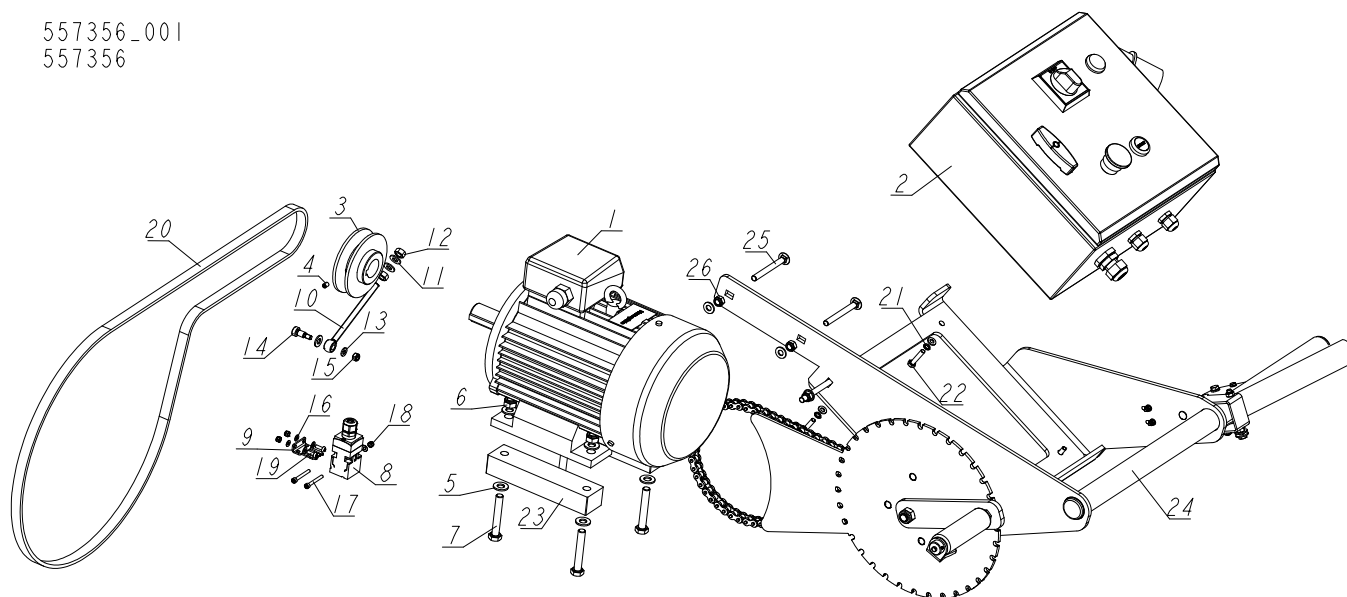

## 4.11 Motor Kit, LX50SA E5 (No. 557356)

557356\_001  
557356

REF	DESCRIPTION (u indicates parts available in assemblies only)	PART #	QTY	
-	MOTOR KIT,LX50SA E5S COMPLETE	557356	1	
-	MOTOR KIT,LX50SA E5 COMPLETE	557356-3	1	
1	MOTOR, 3SIE100L2A 4KW 2900 R.P.M. 50HZ	537387	1	
2	BOX, LX50SA EH5S ELECTRICAL <a href="#">See Section 4.13</a>	526996	1	
3	SHEAVE, LX50SA EH5	550789-1	1	
4	SCREW, M6X8 HEX SOCKET SET CONE POINT ZI	F81013-1	1	
5	WASHER, 10.5 FLAT ZINC	F81055-1	8	
6	NUT, M10-8-B HEX NYLON ZINC LOCK	F81033-1	4	
7	BOLT, M10X65-8.8-B HEX HEAD ZINC	F81003-67	4	
8	SWITCH, AZ17-11ZRK SAFETY 1	094232	1	
9	KEY, AZ17/170-B5 SAFETY SWITCH 2	094422	1	
10	BOLT, M8X120 8.8 DIN444 EYE	F81002-64	1	
11	WASHER, 8.4 FLAT ZINC	F81054-1	6	
12	NUT, M8-8-B HEX ZINC	F81032-1	2	
13	WASHER, 6.4 FLAT ZINC	F81053-1	5	
14	BOLT, 8/M6X12-12.9 ISO 7379 SHOULDER	F81001-56	1	
15	NUT, M6-8-B HEX NYLON ZINC LOCK	F81031-2	1	
16	WASHER, 4.3 FLAT ZINC	F81051-2	6	
17	SCREW, M4X35 8.8 HEX SOCKET HEAD CAP ZIN	F81011-34	2	
18	NUT, M4-8 HEX NYLON ZINC LOCK	F81029-1	4	
19	SCREW, M4X12 5,8-B CROSS RECESSED PAN HE	F81011-43	2	
20	V-BELT, BX71 17X1848 LD (CONTITECH)	551001	1	
21	WASHER, Z 6.1 SPLIT LOCK	F81053-3	4	
22	BOLT, M6X30-8.8 HEX HEAD FULL THREAD ZIN	F81001-8	4	
23	SPACER, ELECTRIC MOTOR	550765	2	
24	BASE, ELECTRICAL BOX <a href="#">See Section 4.12</a>	594391	1	
25	BOLT, M8X75 DIN603 CARRIAGE ZINC	F81002-106	3	
26	NUT, M8-8-B HEX NYLON ZINC LOCK	F81032-2	3	

### 4.12 Electrical Box Base (No. 594391)

594391\_001  
594391

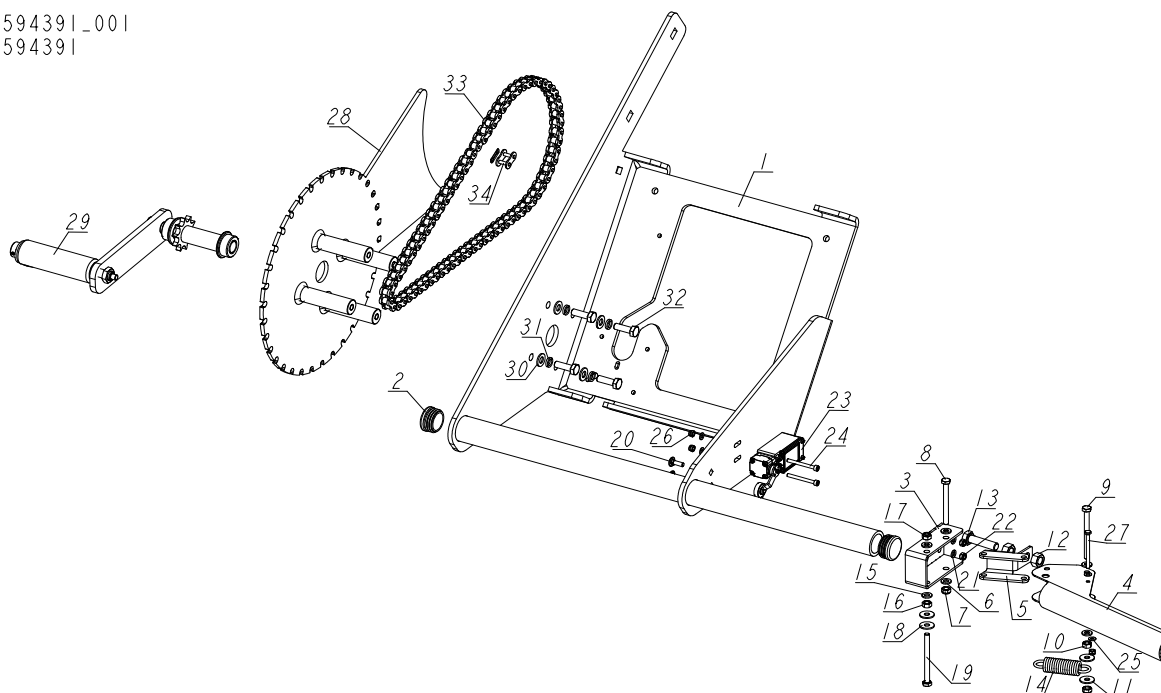

REF	DESCRIPTION (u indicates parts available in assemblies only)	PART #	QTY
-	<b>BASE, ELECTRICAL BOX</b>	594391	1
1	BASE WELDMENT, ELECTRICAL BOX	594392-1	1
2	CAP, SR1530 (HOLE 30) TUBE	517616	2
3	BRACKET WELDMENT	532316-1	1
4	LEVER, CABLE	532336-1	1
-	<b>ASSY, TRIGGER PLATE</b>	595723	1
5	BRACKET	532324-1	1
6	WASHER, 6.4 FLAT ZINC	F81053-1	4
7	NUT, M6-8-B HEX NYLON ZINC LOCK	F81031-2	2
8	BOLT, M6X60-8.8 HEX HEAD FULL THREAD ZIN	F81001-9	1
9	BOLT, M6X70 8.8 HEX HEAD FULL THREAD ZIN	F81001-63	1
10	NUT, M6 8 HEX ZINC	F81031-1	1
11	WASHER, 6.5 SPECIAL FLAT ZINC	F81053-11	2
12	NUT, M10-8-B-HEX ZINC	F81033-3	2
13	BOLT, M10X40-8.8 HEX HEAD FULL THREAD ZI	F81003-16	1
14	SPRING, 3/4X2 7/8X12GA	015479	1
15	WASHER, 6.4 FLAT ZINC	F81053-1	2
16	NUT, M6 8 HEX ZINC	F81031-1	1
17	NUT, M6-8-B HEX NYLON ZINC LOCK	F81031-2	1
18	WASHER, 6.5 SPECIAL FLAT ZINC	F81053-11	2
19	BOLT, M6X70 8.8 HEX HEAD FULL THREAD ZIN	F81001-63	1
20	BOLT, M5X16 DIN 603 CARRIAGE	F81000-75	2
21	WASHER, 5.3 FLAT ZINC	F81052-1	2
22	NUT, M5-8 DIN985 ZINC-PLATED	F81030-2	2
23	SWITCH, FA138 Z11 LIMIT	100931	1

REF	DESCRIPTION (u indicates parts available in assemblies only)	PART #	QTY	
24	SCREW, M4X40-8.8 SOCKET HEAD ZINC	F81011-37	2	
25	WASHER, 4.3 FLAT ZINC	F81051-2	4	
26	NUT, M4-8 HEX NYLON ZINC LOCK	F81029-1	3	
27	BOLT, M4X50-8.8 DIN933 HEX HEAD ZINC	F81011-48	1	
28	SCALE ASSY.	594390-1	1	
29	CRANK, LX50 WINCH	550690	1	
30	WASHER, 8.4 FLAT ZINC	F81054-1	4	
31	WASHER 8,2 SPLIT LOCK ZINC	F81054-4	4	
32	BOLT, M8X25-8.8-B HEX HEAD FULL THREAD Z	F81002-5	4	
33	CHAIN, 08B L-965 (75-LINK)	550695	1	
34	LINK, 08B-1PZ MASTER	091625	1	

**4.13 Electrical Box, LX50 SA (No. 526996)**

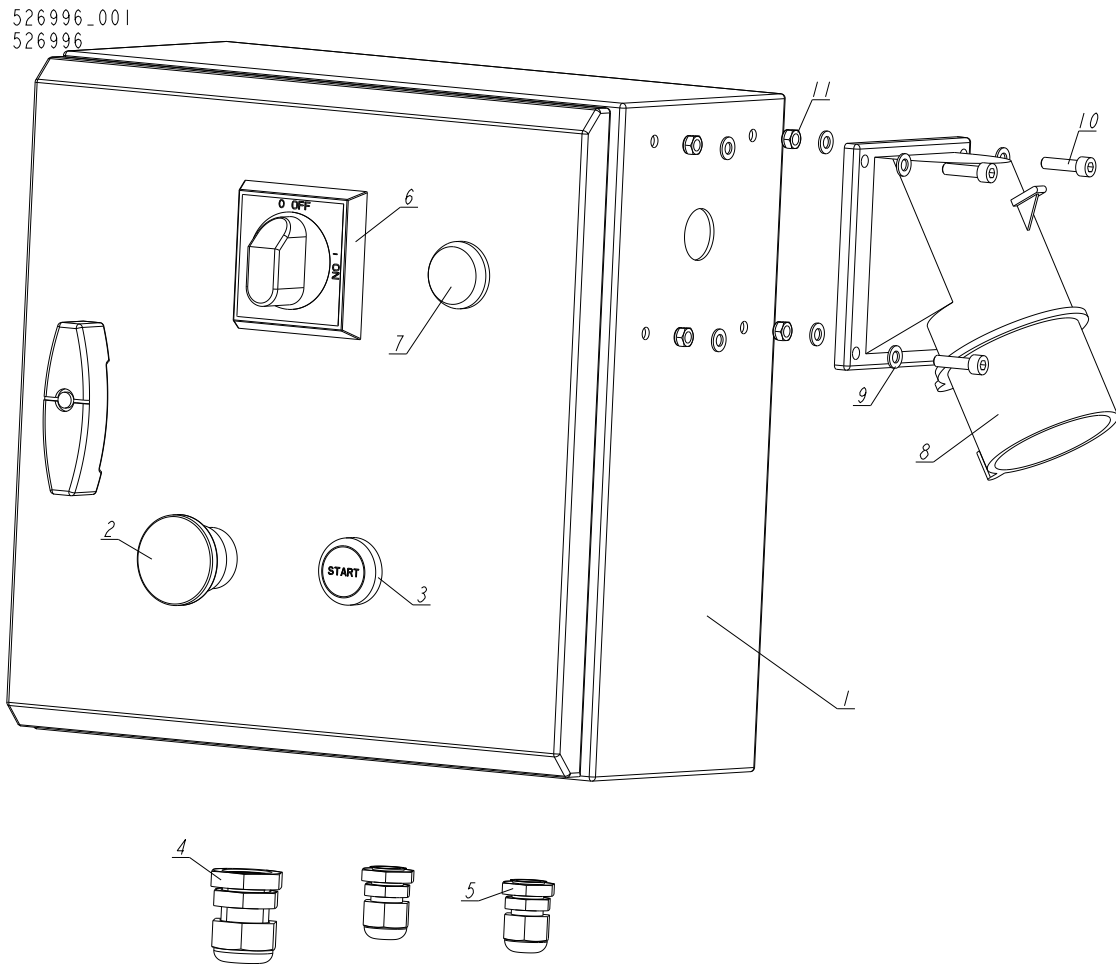

REF	DESCRIPTION (u indicates parts available in assemblies only)	PART #	QTY
-	<b>ELECTRICAL BOX, LX50SA EH5S</b>	526996	1
1	BOX, CONTROL XC100 - 400V	526998	1
2	BUTTON, XB4 BS542 EMERGENCY STOP	086556	1
3	BUTTON, M22 FLAT GREEN	090925	1
4	GLAND, DP16/H CABLE	F81096-7	1
5	GLAND, DP9/H CABLE	F81096-2	2
6	HANDLE, ABB SWITCH	088265-1	1
7	LIGHT, M22 LED 24V BLUE CONTROL	090448	1
8	PLUG, 16A 5P 778152-6 PCE	E85239	1
9	WASHER, 5.3 FLAT ZINC	F81052-1	8
10	BOLT, M5X20-8.8 SOCKET HEAD ZINC	F81000-72	4
11	NUT, M5-8 DIN985 ZINC-PLATED	F81030-2	4

### 4.14 Engine Kit, G9 LX50SA (No. 557357)

557357\_001  
557357

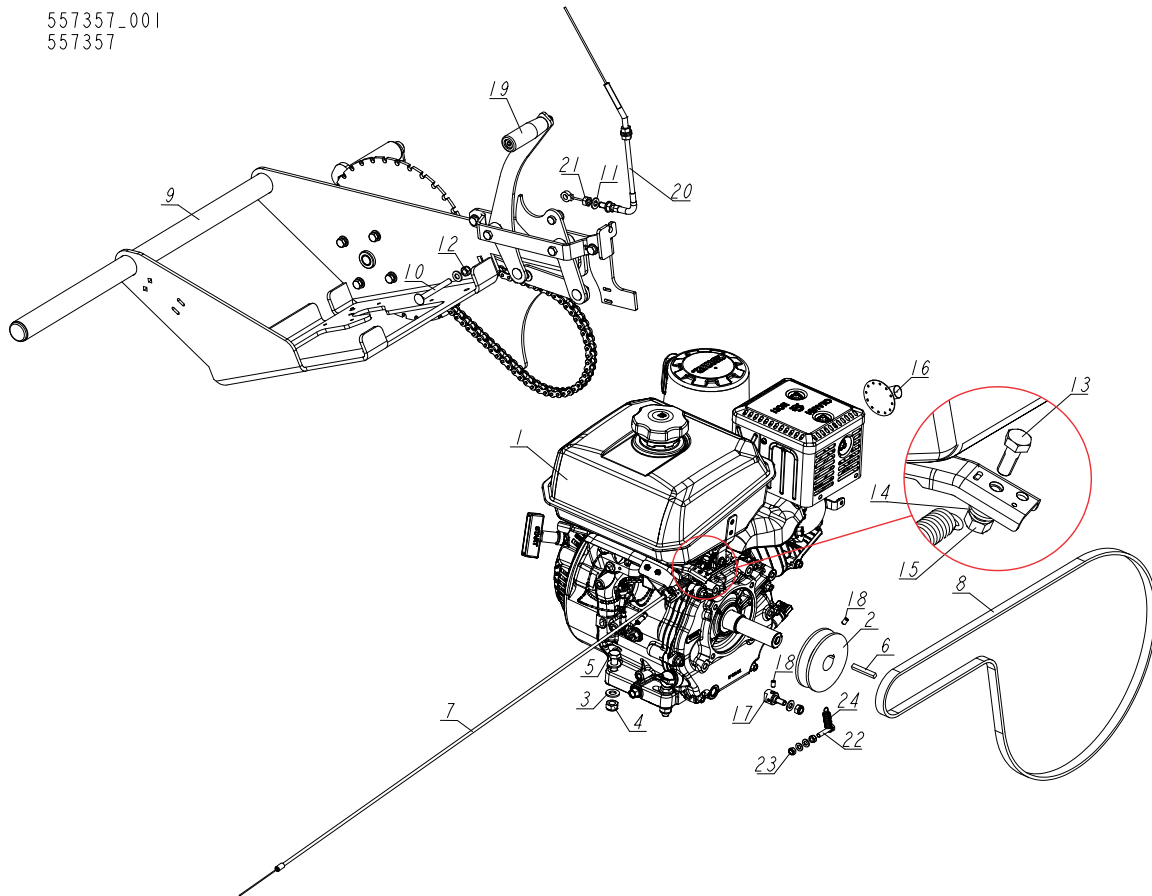

REF	DESCRIPTION (u indicates parts available in assemblies only)	PART #	QTY
-	<b>ENGINE KIT, G9 LX50SA - COMPLETE</b>	557357	1
1	ENGINE, 9.5 HP KOHLER	X100-1091	1
2	SHEAVE, G13/14	550887-1	1
3	WASHER, 10.5 FLAT ZINC	F81055-1	8
4	NUT, M10-8-B HEX NYLON ZINC LOCK	F81033-1	4
5	BOLT, M10X45 HEX HEAD FULL THREAD ZINC	F81003-3	4
6	KEY, 1/4 X 1 11/16	S04124	1
7	CABLE, G14 THROTTLE	550812	1
8	V-BELT, BX71 17X1848 LD (CONTITECH)	551001	1
9	BASE, ELECTRIC BOX	557358	1
10	BOLT, M8X75 DIN603 CARRIAGE ZINC	F81002-106	1
11	WASHER, 8.4 FLAT ZINC, WASHER, 8.4 FLAT,ZINC	F81054-1	6
12	NUT, M8-8-B HEX NYLON ZINC LOCK	F81032-2	2
13	BOLT, THROTTLE CABLE CLAMP ZINC-PLATED	088120-1	1
14	WASHER, 6.4 FLAT ZINC	F81053-1	3
15	NUT, M6 8 HEX ZINC	F81031-1	1
16	DEFLECTOR, KOHLER14HP EXHAUST	110187	1
17	MOUNTING, CABLE	551000-1	1
18	SCREW, M6X10-45H HEX SOCKET ZINC SET W/F	F81001-26	2
19	LEVER, CLUTCH	594396	1

REF	DESCRIPTION (u indicates parts available in assemblies only)	PART #	QTY	
20	CABLE, M120 TENSIONER	534518	1	
21	NUT, M8-8-B HEX ZINC	F81032-1	4	
22	BOLT, M6X30-8.8 HEX HEAD FULL THREAD ZIN	F81001-8	1	
23	NUT, M6-8-B HEX NYLON ZINC LOCK	F81031-2	2	
24	SPRING, LX50 TENSIONER (GRENE NR 0050582350)	593262	1	

## 4.15 Lever clutch 594396

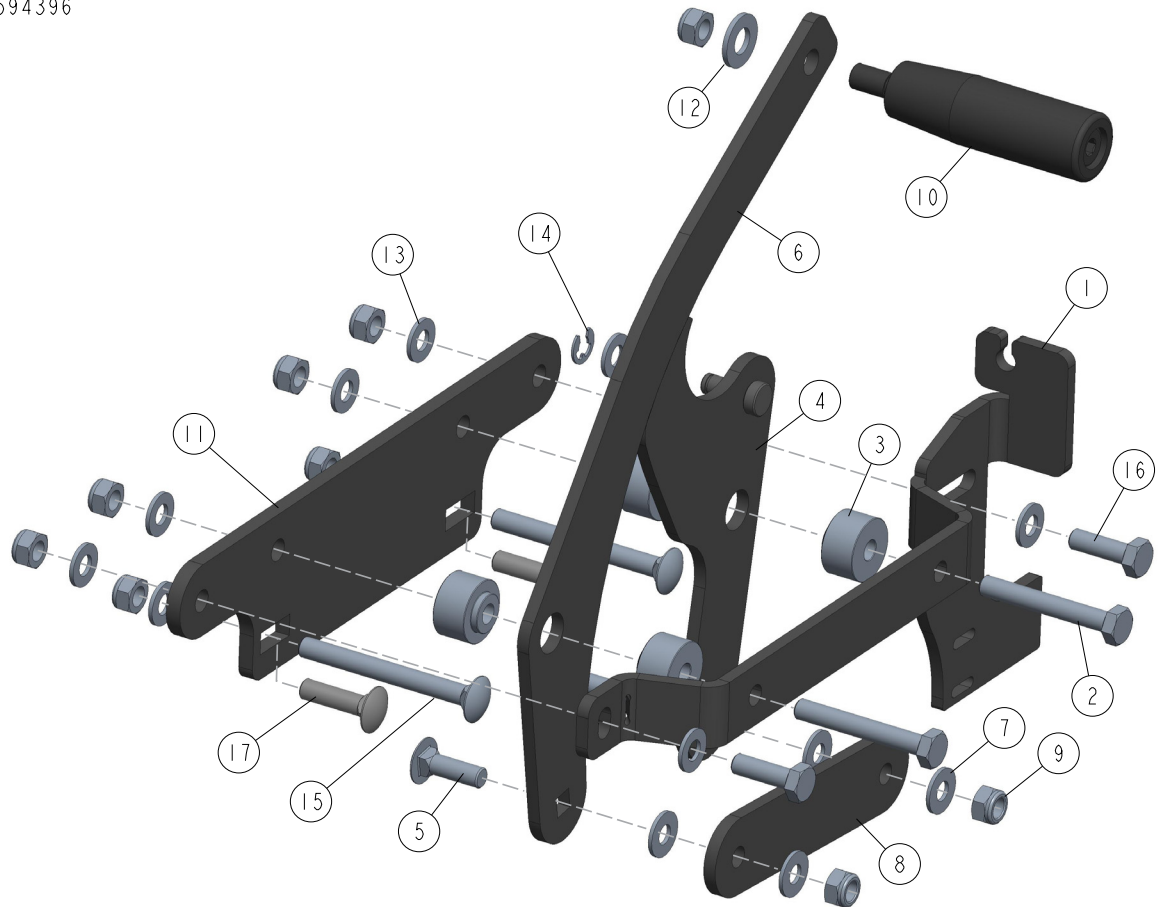
594396\_001  
594396

REF	DESCRIPTION (◆ indicates parts available in assemblies only)	PART #	QTY
-	LEVER, CLUTCH	594396	1
1	PLATE, CLUTCH ARM MOUNTING	595718-1	1
2	BOLT, M8X55-8.8 HEX HEAD ZINC	F81002-8	2
3	SPACER	X100-1325	4
4	CLUTCH PIVOTARM WELDING	595737-1	1
5	BOLT, M8X25-8.8 ZINC MUSHROOM HEAD SQUAR	F81002-59	2
6	PLATE, CLUTCH MOUNTING ARM	X100-1326	1
7	JTM-0818-015	X100-1311	4
8	PLATE, CLUTCH ENGAGEMENT ARM	X100-1310	1
9	NUT, M8-8-B HEX NYLON ZINC LOCK	F81032-2	9
10	KNOB, 12992M10 PLASTIC CRANK HANDLE	086338	1
11	PLATE	534503-1	1
12	WASHER, 10.5 FLAT ZINC	F81055-1	1
13	WASHER, 8.4 FLAT ZINC	F81054-1	9
14	CIRCLIP, 7 DIN6799	F81090-60	1
15	BOLT, M8X75 DIN603 ZINC MUSHROOM HEAD SQ	F81002-106	2
16	BOLT, M8X25-8.8-B HEX HEAD FULL THREAD Z	F81002-5	2
17	BOLT, M8X30-8.8 CARRIAGE ZINC (DIN 603)	F81002-69	2