

**E15**  
**Safety, Operation,**  
**Maintenance, & Parts Manual**

---

**For LX250**

**rev. A1.00**

---

***Safety is our #1 concern!***

*October 2019*

*Form #2415*



**WARNING! Read and understand this manual before using this machine.**

**California**  
Proposition 65 Warning



**WARNING:** Breathing gas/diesel engine exhaust exposes you to chemicals known to the State of California to cause cancer and birth defects or other reproductive harm.

Always start and operate the engine in a well-ventilated area.  
If in an enclosed area, vent the exhaust to the outside.  
Do not modify or tamper with the exhaust system.  
Do not idle the engine except as necessary.

For more information go to **[www.P65warnings.ca.gov](http://www.P65warnings.ca.gov)**.



**WARNING:** Drilling, sawing, sanding or machining wood products can expose you to wood dust, a substance known to the State of California to cause cancer. Avoid inhaling wood dust or use a dust mask or other safeguards for personal protection.

For more information go to **[www.P65Warnings.ca.gov/wood](http://www.P65Warnings.ca.gov/wood)**.

**©2019**

Printed in the United States of America, all rights reserved. No part of this manual may be reproduced in any form by any photographic, electronic, mechanical or other means or used in any information storage and retrieval system without written permission from

**Wood-Mizer**  
**8180 West 10th Street**  
**Indianapolis, Indiana 46214**

**ABOUT THIS MANUAL**

1.1 Safety Symbols.....1-1

**OPERATION**

2.1 Starting The Engine.....2-1

**MAINTENANCE**

3.1 Maintenance Safety .....3-1  
3.2 Electrical Lockout Procedures.....3-1

**REPLACEMENT PARTS**

4.1 Motor Assembly .....4-1  
4.2 Alternator.....4-3  
4.3 Control Assembly.....4-5  
4.4 Blade Motor Harness.....4-7  
4.5 Brake Assembly .....4-8

## SECTION 1 ABOUT THIS MANUAL

This manual is a supplement to the equipment manufacturer's manuals.

This manual provides information specific to the use of this equipment on the Wood-Mizer® equipment. Refer to the operator's manual and manufacturer's manual before attempting to operate this equipment.

**IMPORTANT!** Read the sawmill operator's manual and engine manufacturer's manual for instructions and safety precautions before operating this equipment.

The information and instructions given in this manual do not amend or extend the limited warranties for the equipment given at the time of purchase.

### 1.1 Safety Symbols

The following symbols and signal words call your attention to instructions concerning your personal safety. Be sure to observe and follow these instructions.



**DANGER!** indicates an imminently hazardous situation which, if not avoided, will result in serious injury or death.



**WARNING!** suggests a potentially hazardous situation which, if not avoided, could result in serious injury or death.



**CAUTION!** refers to potentially hazardous situations which, if not avoided, may result in minor or moderate injury or damage to equipment.

**NOTICE** indicates vital information.

## SECTION 2 OPERATION

### 2.1 Starting The Engine

#### MOTOR CONTROL LIGHTS (SEE FIG. 2-1.)



*Alternator Charge Indicator:* Lights if the alternator is not charging the battery.



*Key Switch Indicator:* Lights when the key is in either the on or accessory (1 or 3) position.

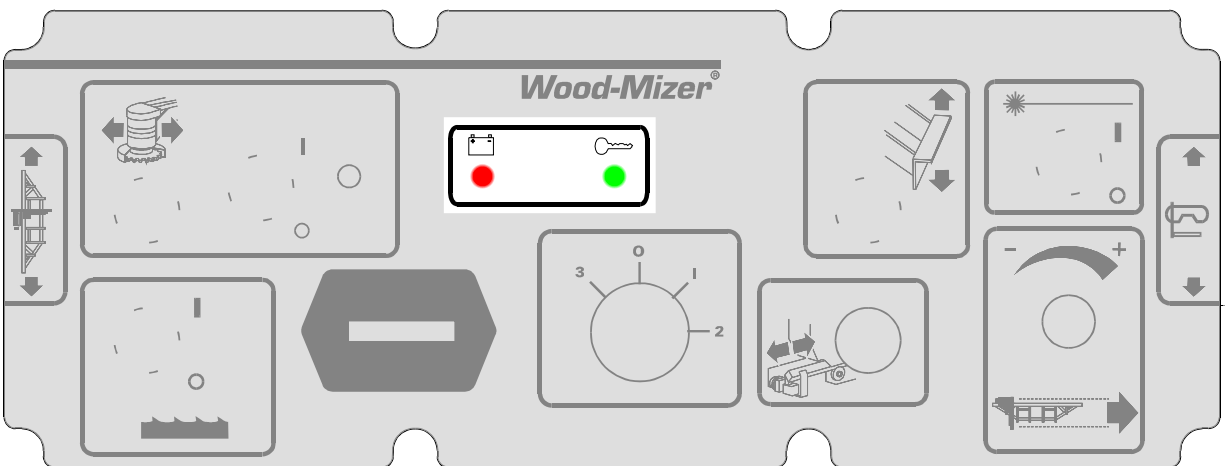

FIG. 2-1

#### MOTOR START



**WARNING!** Always be sure the blade is disengaged and all persons are out of the path of the blade before starting the motor. Failure to do so will result in serious injury.

Ensure the power feed switch is in the neutral position before turning the key switch to the on (1) or accessory (3) position. This prevents accidental carriage movement.

Turn the key switch to the start (2) position and release.

For more information, see the engine manufacturer's operation manual.

**MOTOR SHUTOFF**

Turn the key switch to the off (0) position.

## SECTION 3 MAINTENANCE

Refer to the manufacturer's manual for maintenance intervals and procedures unless otherwise instructed in this manual.

Follow the manufacturer's recommendations for use in dusty conditions.



**WARNING!** Clean sawdust from all guards, vents, control boxes, or any area where sawdust may gather **after every shift**. Failure to do so may result in fire, causing death or serious injury.



### 3.1 Maintenance Safety

Use caution when performing maintenance or service to the motor.



**WARNING!** Ensure all electrical installation, service and/or maintenance work is performed by a qualified electrician and is in accordance with applicable electrical codes.

Stay a safe distance from rotating members.

Ensure that loose clothing, jewelry, or long hair does not engage rotating members resulting in possible injury.

Disconnect and lock out power supply before servicing!

Keep all electrical component covers closed and securely fastened during mill operation.

Remove the blade before performing any engine service. Failure to do so may result in serious injury.

### 3.2 Electrical Lockout Procedures

#### RULES FOR USING LOCKOUT PROCEDURE

The sawmill shall be locked out to protect against accidental or inadvertent operation when such operation could cause injury to personnel. Do not attempt to operate any switch or valve bearing a lock.

**LOCKOUT PROCEDURES MUST BE USED DURING:**

Changing or adjusting blades	Electrical maintenance
Unjamming operations	Retrieval of tools/parts from work area
Cleaning	Activities where guards or electrical panel guard is open or removed
Mechanical repair	

**MAINTENANCE HAZARDS INCLUDE:**

Blade contact	Missiles (thrown blades/wood chips)
Pinch points	Electrical
Kickbacks	

**FAILURE TO LOCKOUT MAY RESULT IN:**

Cut	Serious injury and death
Crush	Amputation
Blindness	Burn
Puncture	Shock
Electrocution	

**TO CONTROL MAINTENANCE DANGERS:**

- Lockout procedures must be followed (see **OSHA regulation 1910.147**).
- Never rely on machine stop control for maintenance safety (emergency stops, on/off buttons, interlocks).
- Do not reach into moving blades or feed systems. Allow all coasting parts to come to a complete stop.
- Electrical power supply and air supply must both be locked out.
- Where established lockout procedures cannot be used (electrical troubleshooting or mechanical dynamic troubleshooting), alternative effective protective techniques shall be employed which may require special skills and planning.
- Always follow safe operations practices in the workplace.

**SAWMILL LOCKOUT PROCEDURE**

Lockout procedures per OSHA regulation 1910.147, appendix A:

**GENERAL**

The following simple lockout procedure is provided to assist owner/operators in developing their procedures so they meet the requirements of **OSHA regulation 1910.147**. When the energy isolating devices are not lockable, tagout may be used, provided the owner/operator



complies with the provisions of the standard which require additional training and more rigorous periodic inspections. When tagout is used and the energy isolating devices are lockable, the owner/operator must provide full operator protection (see OSHA regulation 1910.147, paragraph (c)(3)) and additional training and more rigorous periodic inspections are required. For more complex systems, more comprehensive procedures may need to be developed, documented, and utilized.

## **PURPOSE**

This procedure establishes the minimum requirements for the lockout of energy isolating devices whenever maintenance or servicing is done on machines or equipment. It shall be used to ensure that the machine or equipment is stopped, isolated from all potentially hazardous energy sources and locked out before personnel perform any servicing or maintenance where the unexpected energization or start-up of the machine or equipment or release of stored energy could cause injury.

## **COMPLIANCE WITH THIS PROGRAM**

All personnel are required to comply with the restrictions and limitations imposed upon them during the use of lockout. The authorized personnel are required to perform the lockout in accordance with this procedure. All operators, upon observing a machine or piece of equipment which is locked out to perform servicing or maintenance shall not attempt to start, energize, or use that machine or equipment.

## **SEQUENCE OF LOCKOUT**

1. Notify all affected personnel that servicing or maintenance is required on a machine or equipment and that the machine or equipment must be shut down and locked out to perform the servicing or maintenance.
2. The authorized employee shall refer to the company procedure to identify the type and magnitude of the energy that the machine or equipment utilizes, shall understand the hazards of the energy, and shall know the methods to control the energy.
3. If the machine or equipment is operating, shut it down by the normal stopping procedure (depress the stop button, open switch, close valve, etc.).
4. De-activate the energy isolating device(s) so that the machine or equipment is isolated from the energy source(s).
5. Lock out the energy isolating device(s) with assigned individual lock(s).
6. Stored or residual energy (such as that in capacitors, springs, elevated machine members, rotating flywheels, hydraulic systems, and air, gas, steam, or water pressure, etc.) must be dissipated or restrained by methods such as grounding, repositioning, blocking, bleeding down, etc.
7. Ensure that the equipment is disconnected from the energy source(s) by first checking that no personnel are exposed, then verify the isolation of the equipment by operating the push but-

ton or other normal operating control(s) or by testing to make certain the equipment will not operate.



**CAUTION!** Return operating control(s) to neutral or "off" position after verifying the isolation of the equipment.

8. The machine or equipment is now locked out.

### **RESTORING EQUIPMENT TO SERVICE**

When the servicing or maintenance is completed and the machine or equipment is ready to return to normal operating condition, the following steps shall be taken.

1. Check the machine or equipment and the immediate area around the machine to ensure that nonessential items have been removed and that the machine or equipment components are operationally intact.
2. Check the work area to ensure that all personnel have been safely positioned or removed from the area.
3. Verify that the controls are in neutral.
4. Remove the lockout devices and re-energize the machine or equipment.

**NOTE:** The removal of some forms of blocking may require re-energization of the machine before safe removal.

5. Notify affected personnel that the servicing or maintenance is completed and the machine or equipment is ready for use.

### **PROCEDURE INVOLVING MORE THAN ONE PERSON**

In the preceding steps, if more than one individual is required to lock out the sawmill, **each shall place his own personal lock on the energy isolating devices.**

## SECTION 4 REPLACEMENT PARTS

### 4.1 Motor Assembly

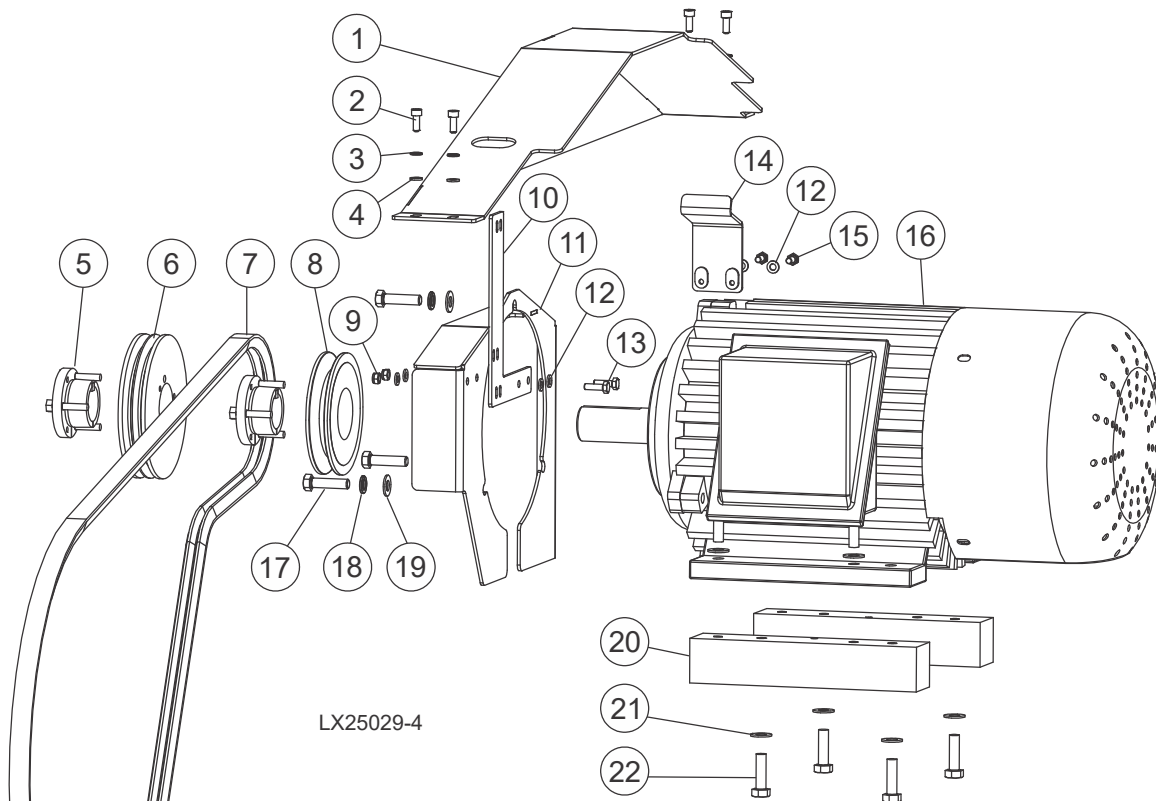

REF	DESCRIPTION (♦ Indicates Parts Available in Assemblies Only)	PART #	QTY.
1	Weldment, E15 Top Belt Cover	128146	1
2	Screw, M6-1.0 x 16mm SHCS	F05004-206	4
3	Washer, M6 Split Lock	F05026-2	4
4	Washer, M6 Flat Class 4	F05026-1	4
5	Bushing, SH 1 3/8 Bore	P21001	2
6	Sheave, 3V5.6x2-SH	047742	1
7	Belt, 2/3VFL900 Drive	047751	1
8	Sheave, LT35 Alternator Drive	062551	1
9	Nut, M6-1.0 Nylon Lock	F05010-200	2
10	Guide, LX250 Clutch Cable	128034	1
11	Weldment, E15 Motor Guard	128155	1
12	Washer, M6 Flat Class 4	F05026-1	4
13	Bolt, M6-1 x 20 Class 8 HH	F05020-6	2
14	Weldment, Belt Enhance Brkt	011447	1

**4****Replacement Parts***Motor Assembly*

---

REF	DESCRIPTION (♦ Indicates Parts Available in Assemblies Only)	PART #	QTY.	
15	Screw, M6-1x12 HHC FT GR8-8 Din 933	F05005-99	2	
16	Motor, 15HP 3520RPM Leeson Wattsaver17	074780	1	
17	Bolt, 3/8-16 x 1 1/2 HH FT Znc	F05007-17	3	
18	Washer, 3/8 Split Lock	F05011-4	3	
19	Washer, 3/8 Flat SAE	F05011-3	3	
20	Block, E15 Riser	117085	2	
21	Bolt, M10-1.5 x35 HH Class 8.8	F05022-18	8	

## 4.2 Alternator

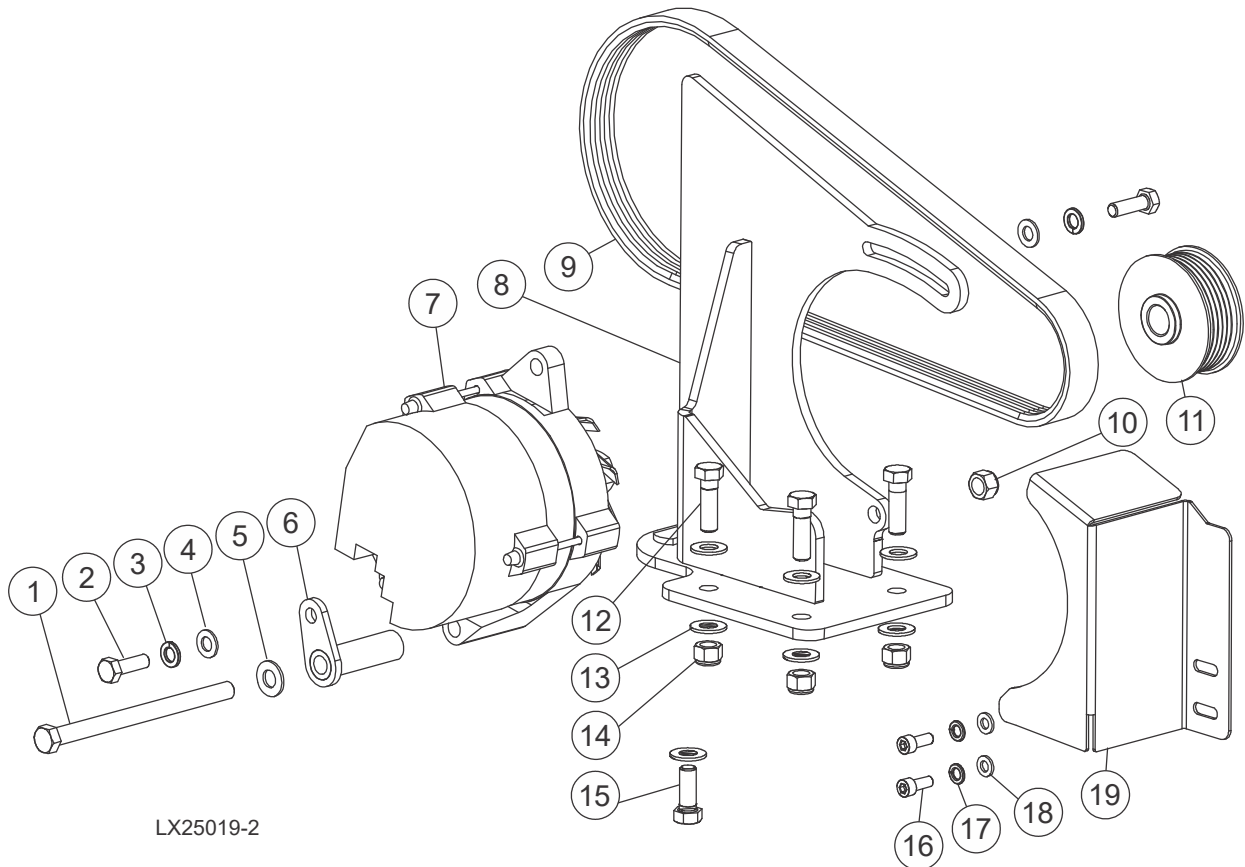

REF	DESCRIPTION (♦ Indicates Parts Available in Assemblies Only)	PART #	QTY.
1	Bolt, M10-1.5x140 HH FT	F05022-21	1
2	Bolt, M8x1.25x25mm C/S 8.8 Din 933 HH	F05004-40	2
3	Washer, M8 Spring Lock Zinc 100PK	F05011-130	2
4	Washer, M8 Flat	F05026-4	2
5	Washer, M10 Flat SAE	F05011-134	1
6	Brace Wldmt, Alternator	W12761	1
7	Alternator, 105A 12V CS130	050287-1 <sup>1</sup>	1
8	Mount Wldmnt, LX250 G38 Alt	011455	1
9	Belt, A32 Alternator	P12740	1
10	Nut, M10-1.50 Hex Nyl Lock	F05004-270	1
11	Sheave, Alternator	P03806	1
12	Bolt, 3/8-16x1 1/4 FT HH Gr5	F05007-123	3
13	Washer, 3/8 Flat SAE	F05011-3	7
14	Nut, 3/8-16 Hex Nyloc	F05010-10	3
15	Bolt, 3/8-16x1 HH Gr5	F05007-87	1

# 4 Replacement Parts

## *Alternator*

---

REF	DESCRIPTION (♦ Indicates Parts Available in Assemblies Only)	PART #	QTY.	
16	Bolt, M6-1.0x16mm SHCS	F05004-206	2	
17	Washer, M6 Split Lock	F05026-2	2	
18	Washer, M6 Flat Class 4	F05026-1	2	
19	Plate, E15 Alt Cover	128147	1	

1 Alternator 050287-1 replaced 050287 as of 4/2021, per ECN 37893.

### 4.3 Control Assembly

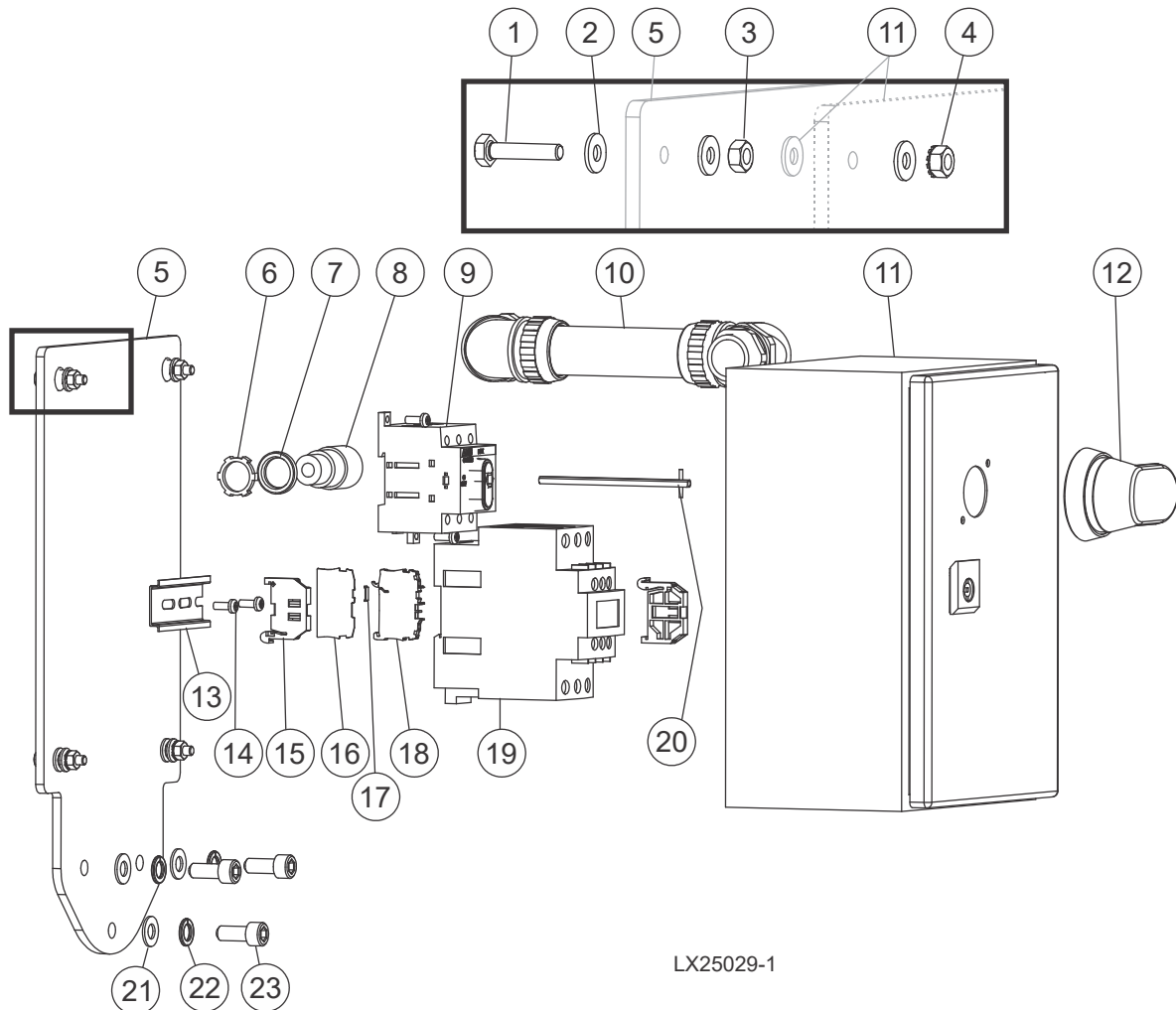

LX25029-1

REF	DESCRIPTION (♦ Indicates Parts Available in Assemblies Only)	PART #	QTY.
	<b>CONTROL ASSY, LX250E</b>	078929	
1	Bolt, 1/4-20x1 1/4 HH Gr5	F05005-116	4
2	Washer, 1/4 SAE Flat	F05011-11	12
3	Nut, 1/4-20 Free Zinc	F05010-63	4
4	Nut, 1/4-20 Keps->	F05010-9	4
5	Plate, LX250E Control Mount	078930	1
6	Nut, 1/2 npt Connector Lock	E20461	1
7	Ring, 1/2 Sealing	E20460	1
8	Connector, 1/2 .125-.375 Portable Cord	E23492	1
9	Disconnect, 63A 600V 3P 6mm Shaft	050881-1	1

# 4

## Replacement Parts

### Control Assembly

REF	DESCRIPTION (♦ Indicates Parts Available in Assemblies Only)	PART #	QTY.	
10	Harness Assy, LX250E Blade Motor	078931	1	
11	Enclosure, LX250 Motor Control	117100	1	
12	Handle, Disconnect RED/TEL Pistol-6mm	050907-1	1	
13	Din Rail, 35mmx7.5mmx1m Steel Sym	024474	1	
14	Bolt, #10-24x1/2 Ph Pan Hd, Type 23	F05015-17	4	
15	Din Clamp, Screwless	051986	2	
16	Terminal Block, 2Pos 2.5mm End Plate	068102	1	
17	Terminal Block, Numbers 1-10 1.5mm	068130	1	
18	Terminal Block, 2Pos 1.5mm Clamp	068100	1	
19	Contact, 65A 3P 24VDC D-A Series	069521	1	
20	Shaft, 290mm Pistol Grip Disconnect	050908-1	1	
	Connector, Ferrule 16AWG 1,5mm Black	024190-16	2	
	Label Set, LX250E Blade Motor Wires	078929-WLBL2	1	
21	Washer, M10 Flat	F05011-134	3	
22	Washer, 10MM Split Lock	F05011-88	3	
23	Bolt, M10-1.5 x 25 SHC	F05022-12	3	



## 4.4 Blade Motor Harness

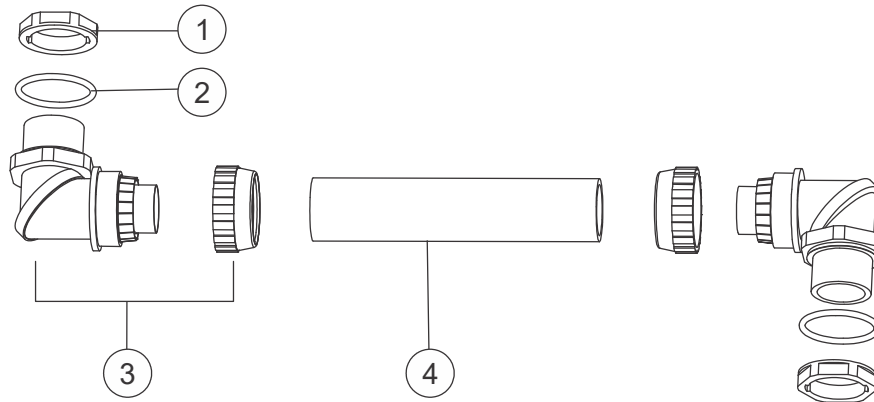

REF	DESCRIPTION (♦ Indicates Parts Available in Assemblies Only)	PART #	QTY.	
	<b>HARNES ASSY, LX250E BLADE MOTOR</b>	078931		
3	Connector, 1" Swivel Liquidtite	024695	2	
2	Ring, 1" Sealing	053734	1	
1	Nut, 1" NPT Connector Lock Sealing	053735	1	
4	Conduit, 1" Diameter Maxiflex Black	R01627	24 in	

# 4 Replacement Parts

## Brake Assembly

### 4.5 Brake Assembly

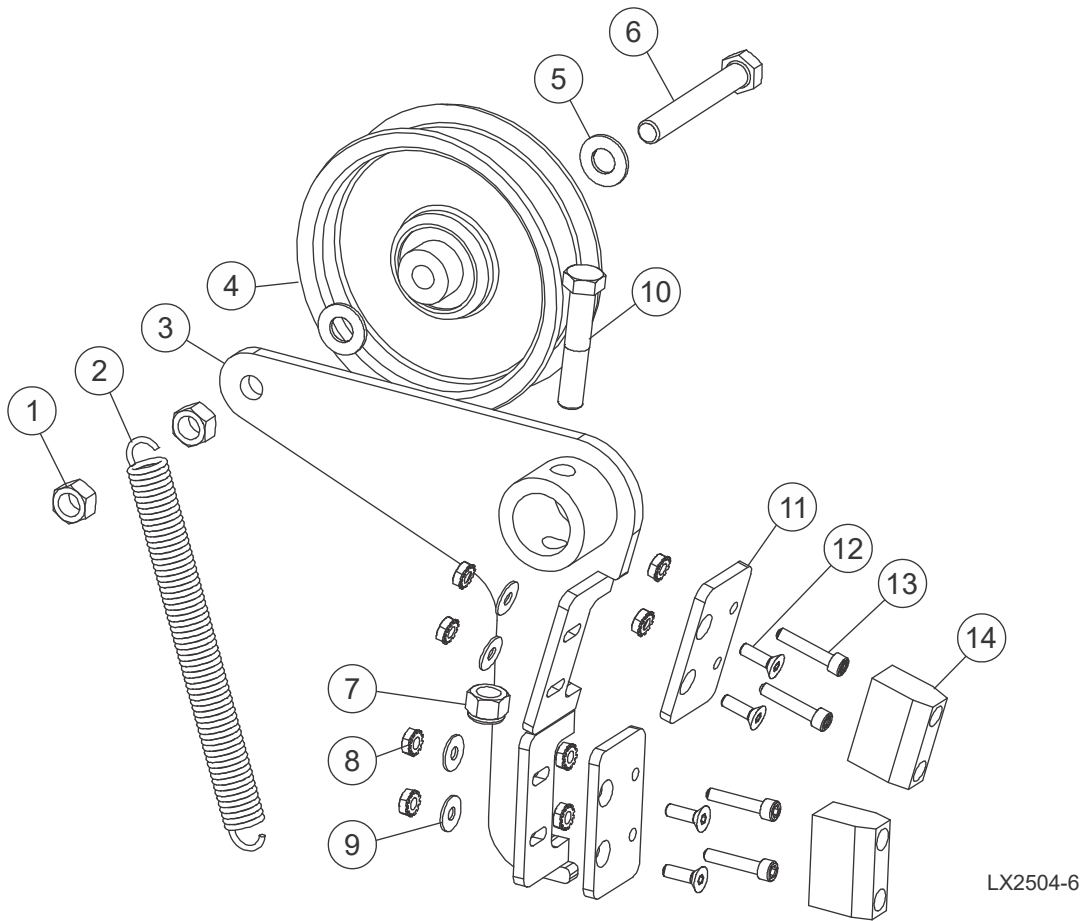

LX2504-6

REF	DESCRIPTION (♦ Indicates Parts Available in Assemblies Only)	PART #	QTY.
	<b>ASSY, BRAKE/CLUTCH</b>	<b>065874</b>	
1	Nut, 3/8-16 Swaged Lock	F05010-25	2
2	Spring, Idler Arm LT15/D/E/G	034810	1
3	Weldment, Clutch/Brake Arm	065873	1
4	Idler, 4" O.D.x 3/8 Bore	034602	1
5	Washer, 3/8 Flat SAE	F05011-3	2
6	Bolt, 3/8-16x2 3/4 FT Gr5	F05007-230	1
7	Nut, 3/8-16 Hex Nyloc	F05010-10	1
8	Nut, #10-24 Keps->	F05010-14	8
9	Washer, #10 SAE Flat	F05011-18	4
10	Bolt, 3/8-16X2 HH GR5	F05007-124	1
11	Plate, Brake Adjustment	065872	2
12	Screw, 10-24x5/8 FSHC BO	F05004-282	4
13	Bolt, 10-24x1 BO SHC	F05004-2	4
14	Block, LT15 Brake	016488	2