

LX 450 D35 Engine

Safety, Operation, Maintenance & Parts Manual

LX450

rev. A1.00 - A1.07



Safety is our #1 concern! Read and understand all safety information and instructions before operating, setting up or maintaining this machine.

January 2018

Form #2312

California
Proposition 65 Warning



WARNING: Breathing gas/diesel engine exhaust exposes you to chemicals known to the State of California to cause cancer and birth defects or other reproductive harm.

Always start and operate the engine in a well-ventilated area.
If in an enclosed area, vent the exhaust to the outside.
Do not modify or tamper with the exhaust system.
Do not idle the engine except as necessary.

For more information go to www.P65warnings.ca.gov.



WARNING: Drilling, sawing, sanding or machining wood products can expose you to wood dust, a substance known to the State of California to cause cancer. Avoid inhaling wood dust or use a dust mask or other safeguards for personal protection.

For more information go to www.P65Warnings.ca.gov/wood.

Active Patents assigned to Wood-Mizer, LLC

Wood-Mizer, LLC has received patents that protect our inventions which are a result of a dedication to research, innovation, development, and design. Learn more at: woodmizer.com/patents

©2024 Wood-Mizer LLC

Printed in the United States of America, all rights reserved. No part of this manual may be reproduced in any form by any photographic, electronic, mechanical or other means or used in any information storage and retrieval system without written permission from

Wood-Mizer, LLC
8180 West 10th Street
Indianapolis, Indiana 46214

Table of Contents		Section-Page
SECTION 1	ABOUT THIS MANUAL	1-1
SECTION 2	OPERATION	2-1
2.1	Starting The Engine.....	2-1
SECTION 3	MAINTENANCE	3-1
3.1	Safety.....	3-1
3.2	Cooling System.....	3-1
3.3	Air Cleaner.....	3-2
3.4	Fuel Filter.....	3-2
3.5	Battery.....	3-2
3.6	Alternator Belt.....	3-3
3.7	RPM Adjustments.....	3-3
3.8	Miscellaneous Maintenance.....	3-4
SECTION 4	REPLACEMENT PARTS	4-1
4.1	Engine Assembly.....	4-1
4.2	Engine Mount Assembly.....	4-3
4.3	Alternator Assembly.....	4-5
4.4	Bearing Support Assembly.....	4-6
INDEX		I

SECTION 1 ABOUT THIS MANUAL

This manual is provided as a supplement to the equipment manufacturer's manuals. This manual provides information specific to the use of this equipment on the Wood-Mizer® sawmill. Refer to the sawmill operator's manual and manufacturer's manual before attempting to operate this equipment.





NOTICE Read the sawmill operator's manual and engine manufacturer's manual for instructions and safety precautions before operating this equipment.

The information and instructions given in this manual do not amend or extend the limited warranties for the equipment given at the time of purchase.

SECTION 2 OPERATION

2.1 Starting The Engine

ENGINE CONTROL LIGHTS

-  *Alternator Charge Indicator:* Lights up if the alternator is not charging the battery.
-  *Engine Temperature Indicator:* Not used.
-  *Key Switch Indicator:* Lights up when the key is in either the on or accessory (1 or 3) position.
-  *Oil Indicator:* Lights up if the oil pressure is too low. The engine will automatically switch to low idle if a low oil condition occurs.
-  *Glow Plug Indicator:* Not used.

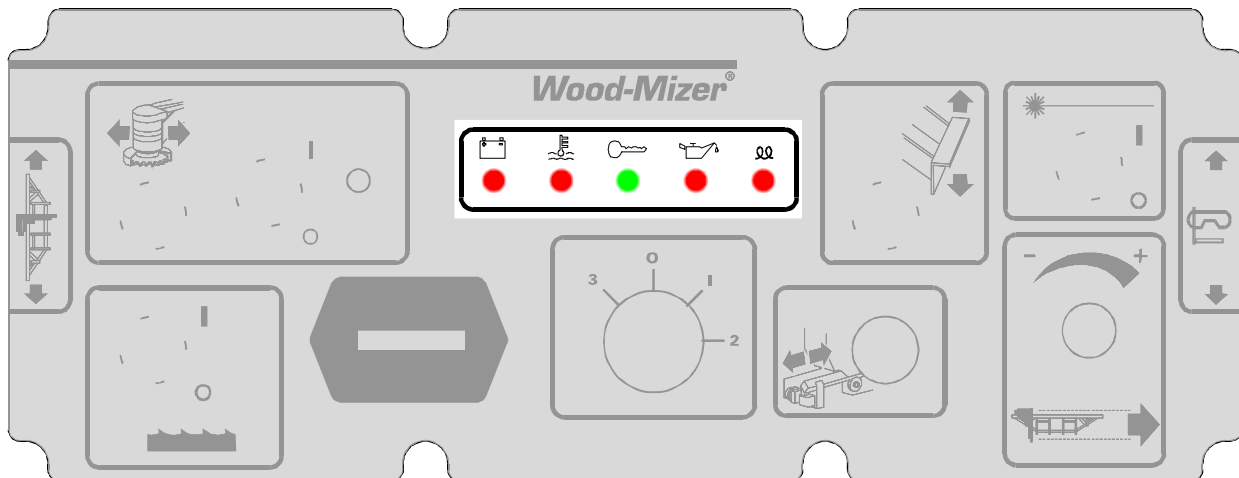

FIG. 2-1

ENGINE START



DANGER! Operate your engine/machine only in well ventilated areas. The exhaust gases of your engine can cause nausea, delirium and potentially death unless adequate ventilation is present.



WARNING! Be sure the power feed switch is in the neutral position before turning the key switch to the on (1) or accessory (3) position. This prevents accidental carriage movement which may cause serious injury or death.

Do not operate engine without proper and operational spark arrester/muffler. Sparks emitted from the engine exhaust could ignite surrounding materials, causing serious injury or death.

Disengage the blade and remove all persons out of the path of the blade before starting the engine. Failure to do so may result in serious injury.

Never operate an engine with a fuel or oil leak. The leaking fuel or oil could potentially come in contact with hot surfaces and ignite into flames.

NOTE: Always relieve all fuel pressure inside the tank prior to filling or connecting fuel fittings. Failure to do so may result in fuel spillage.

NOTE: Disconnect the fuel tank when not in use or during transportation. Failure to do so may result in engine flooding or fuel spillage.

NOTE: Do not engage the clutch lever repeatedly without the engine running. The engine floods when the throttle solenoid is engaged, an accelerator pump is activated which supplies fuel to the engine carburetor.

1. Turn the key switch momentarily to the start (2) position and release it to the run position (1).

ENGINE SHUTOFF

Turn the key switch to the off (0) position.

SECTION 3 MAINTENANCE

Refer to the manufacturer's manual for maintenance intervals and procedures unless otherwise instructed in this manual. Follow the manufacturer's recommendations for dusty conditions.

NOTICE This manual only provides information about additional procedures or procedures to be performed at different time intervals than found in the manufacturer's manuals. Refer to the manufacturer's manual for complete maintenance instructions.



WARNING! Clean sawdust from all guards, vents, control boxes, or any area where sawdust may gather **after every shift**. Failure to do so may result in fire, causing death or serious injury.



3.1 Safety

Use caution when performing maintenance or service to the engine.



DANGER! Always be aware of and take proper protective measures against rotating shafts, pulleys, fans, etc. Always stay a safe distance from rotating members and make sure that loose clothing or long hair does not engage rotating members resulting in possible injury.

Engine components can become very hot during operation. Avoid contact with any part of a hot engine. The exhaust components of your engine are especially hot during and following operation. Contact with hot engine components can cause serious burns. Therefore, never touch or perform service functions on a hot engine. Allow the engine to cool sufficiently before beginning any service function.



WARNING! Remove the blade before performing any engine service. Failure to do so may result in serious injury.

Always wear proper and necessary safety equipment when performing service functions. Proper safety equipment includes eye protection, breathing protection, hand protection and foot protection.



This symbol identifies the interval (hours of operation) at which each maintenance procedure should be performed. "AR" signifies maintenance procedures which should be performed as required.

3.2 Cooling System



Wash the engine or brush off sawdust and debris every 50 hours of operation. Clean the grass screen, cooling fins, and external surfaces. Remove any dust, dirt or oil. See engine manual for further instructions.

3.3 Air Cleaner



WARNING! Always wear proper and necessary safety equipment when performing service functions. Proper safety equipment includes eye protection, breathing protection, hand protection and foot protection.



Replace the outer air cleaner cartridge and check the inner cartridge every 250 hours of operation or more often if operating the sawmill in dirty conditions or if engine performance indicates a new cartridge is necessary.



CAUTION! Do not clean elements with water or compressed air. Do not handle the inner element unless it is to be changed. Handle new elements carefully. Contact with the element could cause damage and prevent the filter from operating properly.



Replace the inner air cleaner cartridge every 1200 hours of operation or more often if operating the sawmill in dirty conditions.

3.4 Fuel Filter



Replace the fuel filter every 100 hours of operation or as required for engine performance.

3.5 Battery



Check the battery electrolyte level every 50 hours of operation. See manufacturer's manual for instructions.



DANGER! Batteries expel explosive gases. Keep sparks, flames, burning cigarettes, or other ignition sources away at all times. Always wear safety goggles and a face shield when working near batteries. Failure to do so will cause serious injury.¹



WARNING! Battery posts, terminals and related accessories contain lead and lead compounds, chemicals known to the State of California to cause cancer and reproductive harm. Wash hands after handling.

1. Battery Council International, copyright 1987

3.6 Alternator Belt



The belt tension should be checked after the first 100 hours of operation, when the battery is not charging properly or when the alternator belt is squealing.

If the battery continues to not charge properly or the belt continues to squeal after the initial belt adjustment, replace the belt.

1. Release the blade tension and remove the blade from the sawmill if necessary. Turn the key switch to OFF (0) and remove the key.
2. Remove the drive belt cover and alternator cover.

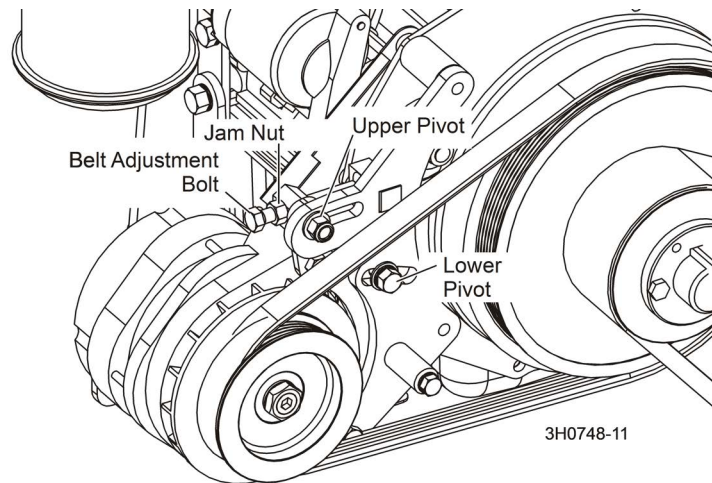

FIG. 3-1

3. Use a belt tension gauge to measure the belt tension. Place the gauge on the belt at the midpoint between the two pulleys. If the belt tension is less than 3/16" with 9 lb. of deflection, tighten the belt as described below.
4. Loosen the upper pivot, lower pivot and the adjustment bolt jam nut.
5. Turn the belt tension adjustment bolt clockwise to tighten the belt, counterclockwise to loosen the belt. Adjust the bolt until the proper belt tension is achieved.



CAUTION! Do not overtighten the alternator belt. Damage to the alternator will occur.

6. After the alternator belt has been tensioned, tighten the adjustment bolt jam nut. Tighten the upper and lower pivots and replace the belt covers.

3.7 RPM Adjustments



WARNING! Remove the blade before performing any engine service. Failure to do so may result in serious injury.



Check the RPM with a tachometer every 200 hours of operation.

Engine	High End RPM	Low End RPM
D35	3000	1500

TABLE 3-1

Before checking the RPM, make sure belt and brake strap tensions are correct (See Sawmill Maintenance). Also check oil, fuel, and coolant levels.

Make sure the throttle cable does not affect the engine RPM when the throttle solenoid is disengaged. Make sure the cable is not bent or kinked. **NOTE:** It is important that the above components are aligned. Proper alignment allows any slack in

the cable (when engine is idling) to slide down into the cable spring. This maintains free operation of the cable and prevents the cable from kinking. Make sure the shoulder bolt does not rub against the crankcase vent tube.

1. Start the engine to measure the low-end RPM.
2. Refer to the engine manual to adjust the low-end RPM.
3. Engage the throttle solenoid to throttle the engine and measure the high-end RPM. The high-end RPM is factory-set at 3000. Readjust the throttle cable if necessary to increase or reduce the high-end engine speed.

The throttle cable should be tensioned just enough so that the engine revs as soon as the clutch/brake handle is engaged. NOTE: A properly adjusted throttle will extend the cable spring 1/4" to 3/8" (6.4 - 9.5 mm) when running and have a slight amount of slack in the cable when idling.

3.8 Miscellaneous Maintenance



Clean and inspect the spark arrester every 50 hours of operation. Replace if damaged.

Review the manufacturer's engine manual for maintenance intervals.

SECTION 4 REPLACEMENT PARTS

4.1 Engine Assembly

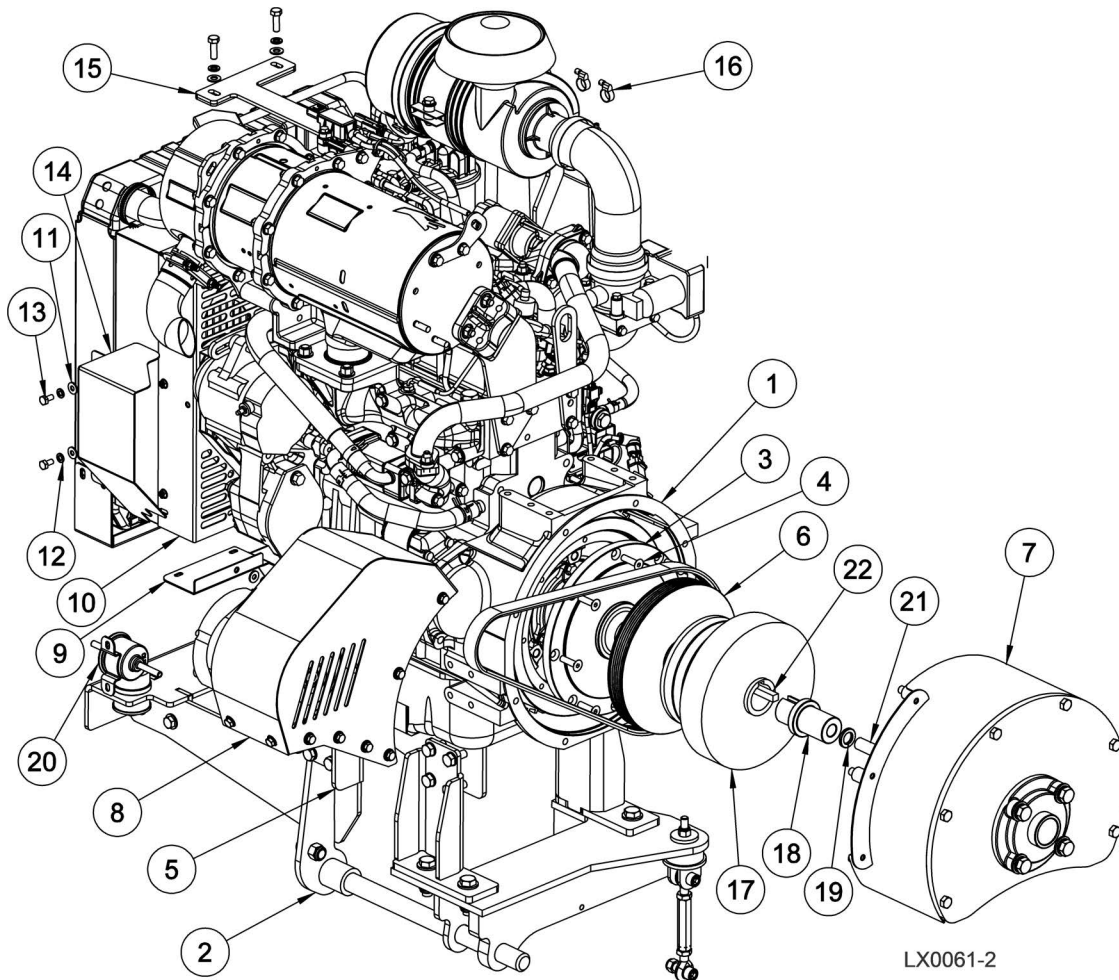

REF	PART #	DESCRIPTION	COMMENTS	QTY.
	107943	ASSEMBLY, D35 T4 DIESEL ENGINE LX450		1
1	079323	Engine, Yanmar D35 Tier4 Final Diesel		1
2	107947	Assembly, D35 T4 Motor Mount LX450		1
3	107946	Shaft, D35 T4 Yanmar Stub LX450		1
4	F05004-245	Screw, M8x1.25x30mm Flat Socket C/S BO		8
5	079399	Assembly, D35 T4 140 Amp Alternator		1
6	107944	Pulley, Alternator Drive		1
7	107949	Assembly, D35 T4 Bearing Support 450		1
8	079544	Assembly, D35 T4 Alternator Cover		1
	079627	Assembly, D35 T4 Radiator Cover		1
9	006604	Weldment, Lower Radiator Cover		1
10	079477	Weldment, D35 T4 Radiator Cover		1
11	F05011-11	Washer, 1/4 SAE Flat		4
12	F05011-14	Washer, 1/4 Split Lock		4
13	F05005-15	Bolt, 1/4-20x1/2 Hex Head		4
14	079478	Plate, D35 T4 Yanmar Alt Cover		1

REF	PART #	DESCRIPTION	COMMENTS	QTY.
15	074228	Assembly, Yanmar 35.9HP Upper Radiator Mnt		1
16	P649	Hose Clamp, 7/32in-5/8in		2
17	107919	Clutch, Centrifugal		1
18	107945	Bushing, Spacer		1
19	F05011-118	Washer, 5/8 Split Zinc Lock Gr8		1
20	079332	Pump, Yanmar T4 Final Fuel Feed		1
21	F05009-145	Bolt, 5/8-18x4 1/2 Hex HeadC Grd 5 Zinc		1
22	107990	Key, 3/8 Sq x 4-7/8		1
	107998	Belt, 3/5VXFL1010		1
		Service Parts		
	006541	Air Cleaner Assembly, 35.9HP Yanmar		1
	057948	Air Filter, Yanmar 3TNV88 #129087-12510		1
	061100	Cap, Air Filter Assembly Yanmar		1
	057935	Filter, Oil #129150-35170		1
	061308	Filter, Fuel #129A00-55800		1
	061309	Filter Assembly, Fuel/Water Separator #129A00-59700		1
	061436	Cup Assembly, Fuel/water Separator		1
	061318	Seal, Fuel/water Separator		1
	006561	Bracket, Fuel/Water Separator Mount		1
	061310	Filter, Water Separator Yanmar #129A00-55730		1
	006543	Muffler Assembly, 35.9HP Yanmar Diesel		1
	061773	Gasket, Yanmar Bonnet #129004-11310		1
	057931	Gasket Set, Yanmar Engine #719823-92960		1
	057932	Seal, Yanmar Front Main #119934-01800		1
	078716	Injector Assembly, Yanmar #129A00-53100		1
	061245	Switch, Yanmar Oil Pressure #119761-39450		1
	061311	Seal, Yanmar Rear Main #129795-01780		1
	057937	Starter Motor, Yanmar #129242-77010		1
	057938	Thermostat, Yanmar #129155-49801		1
	061312	Gasket, Thermostat #129150-49811		1
	044652	Gasket, Thermostat Cover #129795-49551		1
	061313	Pump, Yanmar Water #129A01-42000		1
	057940	Gasket, Yanmar Water Pump #129486-42021		1
	061172	Sender, Yanmar Water Temperature #129927-44900		1
	AP0114	Fan, Engine 7 Blade 360mm #121267-44741		1
	057943	Plug, Yanmar Oil Drain #119640-01640		1
	057946	Dip Stick, Yanmar Oil #129004-34802		1
	044668	Belt, Yanmar Fan #25132-003600		1
	061078	Heater, Yanmar Engine Block #171015-77900		1
	061226	Cable, Heater Engine Block D35/D47		1
	061438	Plug Assembly, Yanmar		1
	061439	Float, Yanmar (red ring)		1

4.2 Engine Mount Assembly

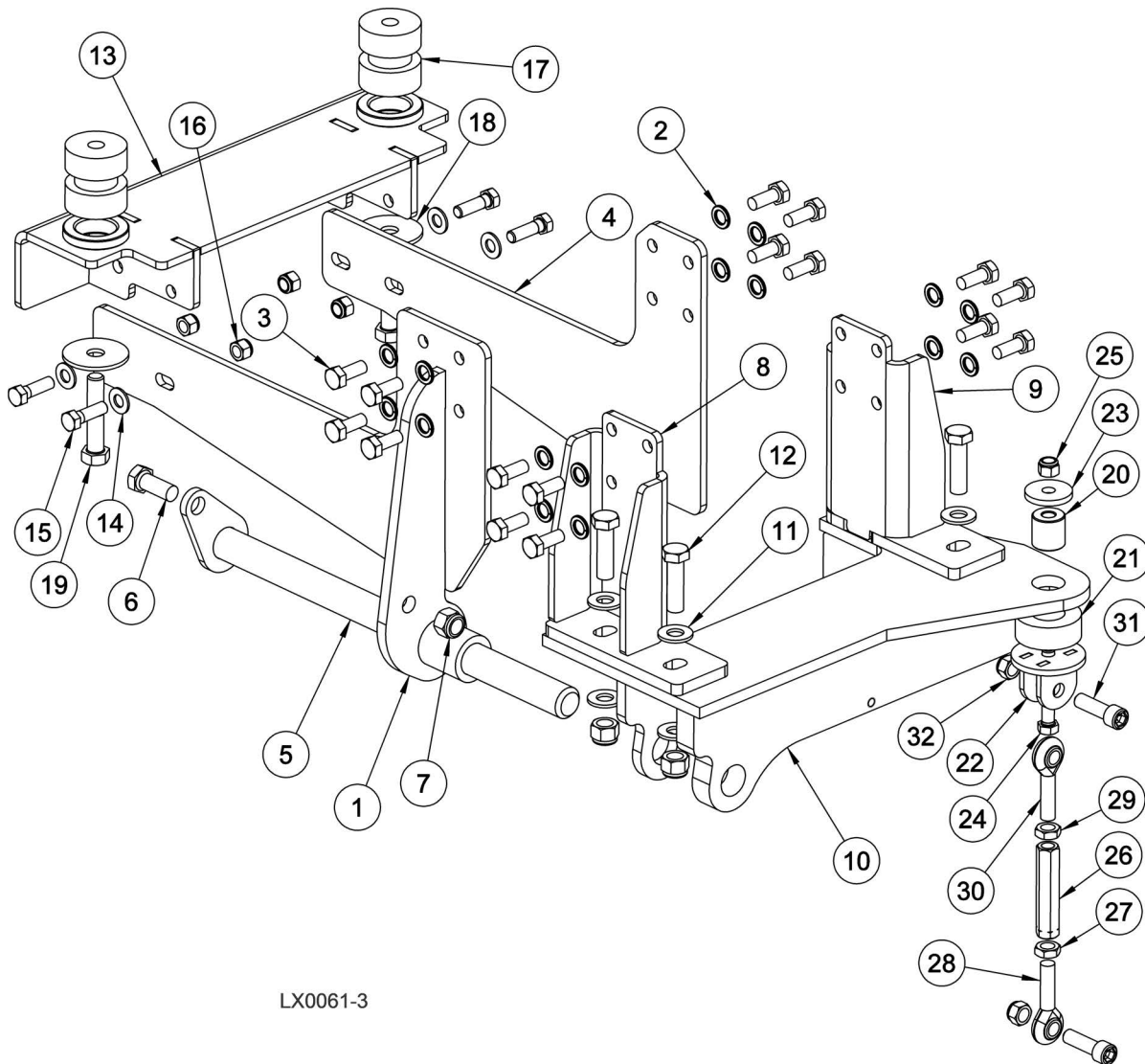

LX0061-3

REF	PART #	DESCRIPTION	COMMENTS	QTY.
	107947	ASSEMBLY, D35 T4 MOTOR MOUNT LX450		1
1	079350	Weldment, 35.9HP T4 Front Engine Mnt		1
2	F05011-88	Washer, 10MM Split Lock		16
3	F81003-11	Bolt, M10-1.5x25 Hex Head Cl 8.8		16
4	058714	Plate, Yanmar Front Engine Mount		1
5	015855	Pin Weldment, Motor Pivot, 1x15 1/8		1
6	F05008-37	Bolt, 1/2-13x1 1/4 Hex Head GR5 Zinc		1
7	F05010-8	Nut, 1/2-13 Nyl Hex Lock		5
8	079372	Weldment, D35 T4 Left Engine Mnt		1
9	079377	Weldment, D35 T4 Right Engine Mnt		1
10	107948	Weldment, D35 T4 Engine Pivot LX450		1
11	F05011-2	Washer, 1/2 SAE Flat		8
12	F05008-88	Bolt, 1/2-13x1 3/4 Hex HeadGR5 FT Zinc		4
	074229	Assembly, Yanmar Lower Radiator Mnt		1
13	006530	Weldment, Yanmar Radiator Mount		1
14	F05011-3	Washer, 3/8 Flat SAE		4

4 Replacement Parts

Engine Mount Assembly

REF	PART #	DESCRIPTION	COMMENTS	QTY.
15	F05007-123	Bolt, 3/8-16x 1 1/4 Hex Head Gr5		4
16	F05010-10	Nut, 3/8-16 Hex Nyl Lock		4
17	018734	Bushing, Rubber Mount		2
18	018751	Washer, Motor Mount		2
19	F05008-74	Bolt, Hex Head 1/2-13x2 1/2 Gr5 Zinc		2
	107955	Turnbuckle/Bushing Assembly		1
20	106911	Bushing, 1 ODx.39IDx1 Long		1
21	P05032	Bushing, Clutch		1
22	W12411	Yoke Weldment, Clutch		1
23	021276	Washer, .40x1.44x.18		1
24	F05007-157	Bolt, 3/8-16x2 1/2 Hex Head FT, Zinc		1
25	F05010-10	Nut, 3/8-16 Hex Nyl Lock		1
	107956	Turnbuckle Assembly, 3 Clutch		1
26	S11577	Turnbuckle, 3" Clutch		1
27	F05010-87	Nut, 7/16-20 Left Hand Jam, Zn		1
28	P11578	Rod End, 7/16-20 Lh Male		1
29	F05010-38	Nut, 7/16-20 Jam, Zn		1
30	P11579	Rod End, 7/16-20 Rh Male		1
31	F05007-55	Screw, 7/16-20x1 1/2 Socket Hd, B/o		2
32	F05010-83	Nut, 7/16-20 Nyl Hex		2

4.3 Alternator Assembly

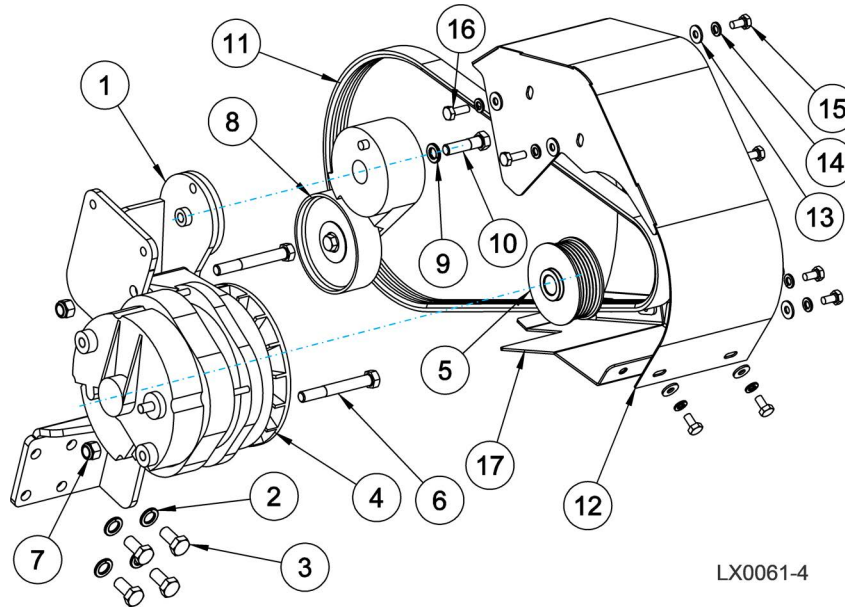

REF	PART #	DESCRIPTION	COMMENTS	QTY.
	079399	ASSEMBLY, D35 T4 140 AMP ALTERNATOR		1
1	079394	Weldment, D35 T4 Alternator Mount		1
2	F05011-88	Washer, 10MM Split Lock		4
3	F05004-207	Bolt, M10-1.50x20mm Hex Head FT 8.8		4
	046429	Alternator Assembly, 140 Amp		1
4	023695	Alternator, 140 Amp		1
5	046402	Sheave, Alternator 2 3/4" O.D.		1
6	F05007-73	Bolt, 3/8-16x3 Hex Head Gr5		2
7	F05010-10	Nut, 3/8-16 Hex Nyl Lock		2
8	034464	Tensioner, Alternator Belt		1
9	F05011-4	Washer, 3/8 Split Lock		1
10	F05007-78	Bolt, 3/8-16X1 1/2 Hex Head Gr5		1
11	107997	BELT, 6PK1120 ALTERNATOR		1
	079544	ASSEMBLY, D35 T4 ALTERNATOR COVER		1
12	079543	Weldment, D35 T4 Alternator Cover		1
13	F05011-11	Washer, 1/4 SAE Flat		10
14	F05011-14	Washer, 1/4 Split Lock		10
15	F05005-15	Bolt, 1/4-20x1/2 Hex Head		8
16	F05005-1	Bolt, 1/4-20x3/4 FT Hex Head Cap		2
17	079576	Weldment, D35 T4 Lower Alt Cover		1

4.4 Bearing Support Assembly

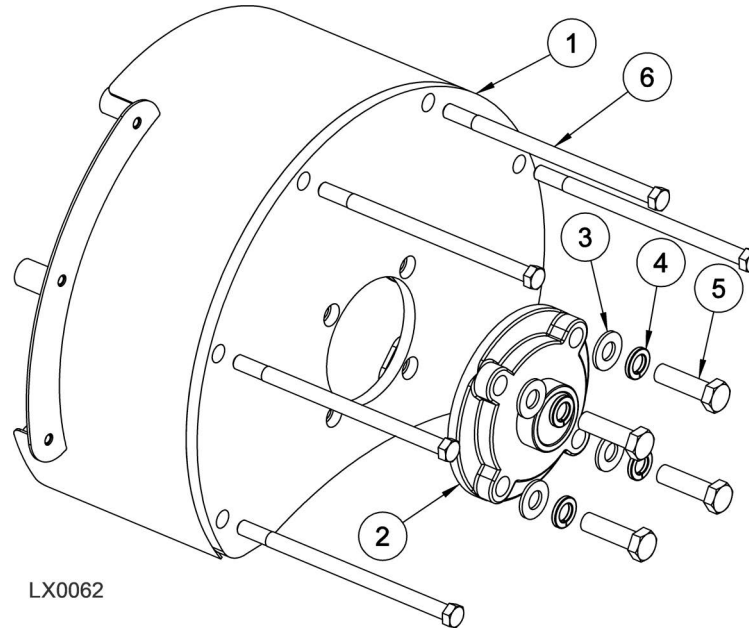

REF	PART #	DESCRIPTION	COMMENTS	QTY.
	107949	ASSEMBLY, D35 T4 BEARING SUPPORT 450		1
1	107950	Weldment, 35HP T4 Brg Support LX450		1
2	071491	Bearing, 1-7/16 4-Bolt Flange		1
3	F05011-2	Washer, 1/2 SAE Flat		4
4	F05011-9	Washer, 1/2 Split Lock		4
5	F05008-102	Bolt, 1/2-13x2 HH Gr5	Replaced (4) F05008-88 after 4/4/24 per ECN 39373	4
	F05008-88	Bolt, 1/2-13x1 3/4 Hex HeadGR5 FT Zinc		4
6	F05022-46	Bolt, M10-1.5x180 Hex Head Class8.8 Zinc	/Removed one (1) F05022-46 due to belt interference. Per ECN 36166 on 11/7/2019.	5

INDEX

M

- maintenance 3-1
 - air cleaner 3-2
 - alternator belt 3-3
 - battery 3-2
 - cooling system 3-1
 - fuel filter 3-2
 - miscellaneous 3-4
 - RPM adjustments 3-3
 - safety 3-1

O

- operation 2-1
 - control lights 2-1
 - shutoff 2-2
 - starting 2-1

P

- parts list
 - drive assembly (460V Ultimate E 140A) 4-5, 4-6
 - engine assembly 4-1
 - motor assembly 4-1
 - motor mount assembly 4-3