

# **G25 Engine for LX150**

## **Safety, Operation, Maintenance & Parts Manual**

---

**011185 Engine Module**

**rev. E.0**

---



**Safety is our #1 concern!** Read and understand all safety information and instructions before operating, setting up or maintaining this machine.

*Form #2276*

**Used with**

---

**LX150G25**

**rev A3.02**

---

**California**  
Proposition 65 Warning



**WARNING:** Breathing gas/diesel engine exhaust exposes you to chemicals known to the State of California to cause cancer and birth defects or other reproductive harm.

Always start and operate the engine in a well-ventilated area.  
If in an enclosed area, vent the exhaust to the outside.  
Do not modify or tamper with the exhaust system.  
Do not idle the engine except as necessary.

For more information go to [www.P65warnings.ca.gov](http://www.P65warnings.ca.gov).



**WARNING:** Drilling, sawing, sanding or machining wood products can expose you to wood dust, a substance known to the State of California to cause cancer. Avoid inhaling wood dust or use a dust mask or other safeguards for personal protection.

For more information go to [www.P65Warnings.ca.gov/wood](http://www.P65Warnings.ca.gov/wood).

**Active Patents assigned to Wood-Mizer, LLC**

Wood-Mizer, LLC has received patents that protect our inventions which are a result of a dedication to research, innovation, development, and design. Learn more at: [woodmizer.com/patents](http://woodmizer.com/patents)

**©2024 Wood-Mizer LLC**

Printed in the United States of America, all rights reserved. No part of this manual may be reproduced in any form by any photographic, electronic, mechanical or other means or used in any information storage and retrieval system without written permission from

**Wood-Mizer, LLC**  
**8180 West 10th Street**  
**Indianapolis, Indiana 46214**

| <b>Table of Contents</b> |                                | <b>Section-Page</b> |
|--------------------------|--------------------------------|---------------------|
| <b>SECTION 1</b>         | <b>ABOUT THIS MANUAL</b>       | <b>1-1</b>          |
| <b>SECTION 2</b>         | <b>OPERATION</b>               | <b>2-1</b>          |
| 2.1                      | Starting The Engine.....       | 2-1                 |
| <b>SECTION 3</b>         | <b>MAINTENANCE</b>             | <b>3-1</b>          |
| 3.1                      | Safety.....                    | 3-1                 |
| 3.2                      | Cooling System.....            | 3-1                 |
| 3.3                      | Air Cleaner.....               | 3-1                 |
| 3.4                      | Fuel Filter.....               | 3-2                 |
| 3.5                      | Battery.....                   | 3-2                 |
| 3.6                      | Alternator Belt.....           | 3-2                 |
| 3.7                      | RPM Adjustments.....           | 3-3                 |
| 3.8                      | Miscellaneous Maintenance..... | 3-4                 |
| <b>SECTION 4</b>         | <b>REPLACEMENT PARTS</b>       | <b>4-1</b>          |
| 4.1                      | Fuel Tank Assembly.....        | 4-1                 |
| 4.2                      | Engine Assembly.....           | 4-3                 |
| 4.3                      | Alternator Assembly.....       | 4-5                 |
| <b>INDEX</b>             |                                | <b>I</b>            |

**Table of Contents**

**Section-Page**

---

## SECTION 1 ABOUT THIS MANUAL

This manual is provided as a supplement to the equipment manufacturer's manuals. This manual provides information specific to the use of this equipment on the Wood-Mizer® sawmill. Refer to the sawmill operator's manual and manufacturer's manual before attempting to operate this equipment.

**NOTICE** Read the sawmill operator's manual and engine manufacturer's manual for instructions and safety precautions before operating this equipment.

The information and instructions given in this manual do not amend or extend the limited warranties for the equipment given at the time of purchase.

## SECTION 2 OPERATION

### 2.1 Starting The Engine

#### ENGINE CONTROL LIGHTS

The following indicator lights are located on the sawmill control panel.

**Alternator Charge Indicator:** Lights up if the alternator is not charging the battery.

**Key Switch Indicator:** Lights up when the key is in either the on or accessory (1 or 3) position.

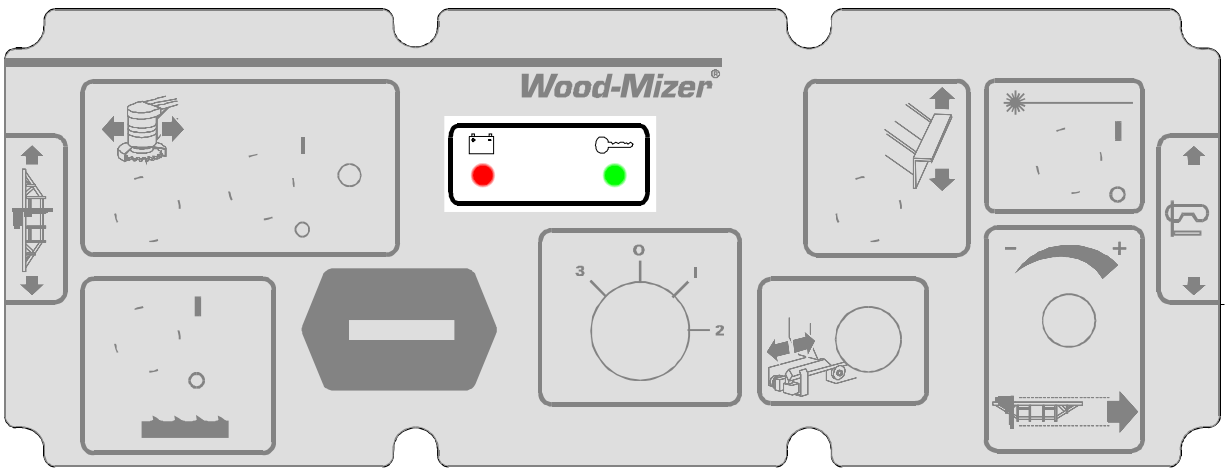

FIG. 2-0

#### ENGINE START

**DANGER!** Always be sure the blade is disengaged and all persons are out of the path of the blade before starting the engine/motor. Failure to do so will result in serious injury.

**DANGER!** Operate your engine/machine only in well ventilated areas. The exhaust gases of your engine can cause nausea, delirium and potentially death unless adequate ventilation is present.

**DANGER!** Never operate an engine with a fuel or oil leak. The leaking fuel or oil could potentially come in contact with hot surfaces and ignite into flames.

**WARNING!** Be sure the power feed switch is in the neutral position before turning the key switch to the on (1) or accessory (3) position. This prevents accidental carriage movement which may cause serious injury or death.

**WARNING!** Do not operate engine without proper and operational spark arrester/muffler. Sparks emitted from the engine exhaust could ignite surrounding materials, causing serious injury or death.

**CAUTION!** Always relieve all fuel pressure inside the tank prior to filling or connecting fuel fittings. Failure to do so may result in fuel spillage.

**CAUTION!** Disconnect the fuel tank when not in use or during transportation. Failure to do so may result in engine flooding or fuel spillage.

Turn the key switch to the start (2) position and release.

For more information, see the engine manufacturer's operation manual.

## **ENGINE SHUTOFF**

Turn the key switch to the off (0) position.

## SECTION 3 MAINTENANCE

Refer to the manufacturer's manual for maintenance intervals and procedures unless otherwise instructed in this manual. Follow the manufacturer's recommendations for dusty conditions.

**IMPORTANT!** This manual only provides information about additional procedures or procedures to be performed at different time intervals than found in the manufacturer's manuals. Refer to the manufacturer's manual for complete maintenance instructions.

**WARNING!** Clean sawdust from all guards, vents, control boxes, or any area where sawdust may gather **after every shift**. Failure to do so may result in fire, causing death or serious injury.



### 3.1 Safety

Use caution when performing maintenance or service to the engine.

**DANGER!** Engine components can become very hot during operation. Avoid contact with any part of a hot engine. The exhaust components of your engine are especially hot during and following operation. Contact with hot engine components can cause serious burns. Therefore, never touch or perform service functions on a hot engine. Allow the engine to cool sufficiently before beginning any service function.

**WARNING!** Remove the blade before performing any engine service. Failure to do so may result in serious injury.

**WARNING!** Always wear proper and necessary safety equipment when performing service functions. Proper safety equipment includes eye protection, breathing protection, hand protection and foot protection.

**WARNING!** Always be aware of and take proper protective measures against rotating shafts, pulleys, fans, etc. Always stay a safe distance from rotating members and make sure that loose clothing or long hair does not engage rotating members resulting in possible injury.

**This symbol** identifies the interval (hours of operation) at which each maintenance procedure should be performed. "AR" signifies maintenance procedures which should be performed as required.

### 3.2 Cooling System

Wash the engine or brush off sawdust and debris every 50 hours of operation.

Clean the grass screen, cooling fins, and external surfaces.

Remove any dust, dirt or oil.

See engine manual for further instructions.

### 3.3 Air Cleaner

**WARNING!** Always wear proper and necessary safety equipment when performing service functions. Proper safety equipment includes eye protection, breathing protection, hand protection and foot protection.

Replace the outer air cleaner cartridge if engine performance indicates a new cartridge is necessary.

Replace the outer air cleaner cartridge and check the inner cartridge every 250 hours of normal operation or (more often if operating the sawmill in dirty conditions).



**CAUTION!** Do not clean elements with water or compressed air. Do not handle the inner element unless it is to be changed. Handle new elements carefully. Contact with the element could cause damage and prevent the filter from operating properly.

Replace the inner air cleaner cartridge every 1200 hours of normal operation (more often if operating the sawmill in dirty conditions).

### 3.4 Fuel Filter

Replace the fuel filter every 100 hours of operation or as required for engine performance.

### 3.5 Battery

Check the battery electrolyte level every 50 hours of operation. See manufacturer's manual for instructions.

**DANGER!** Batteries expel explosive gases. Keep sparks, flames, burning cigarettes, or other ignition sources away at all times. Always wear safety goggles and a face shield when working near batteries. Failure to do so will cause serious injury.<sup>1</sup>

**WARNING!** Battery posts, terminals and related accessories contain lead and lead compounds, chemical known to the State of California to cause cancer and reproductive harm. Wash hands after handling.

### 3.6 Alternator Belt

The belt tension should be checked:

- After the first 100 hours of operation,
- If the battery is not charging properly, or
- If the alternator belt is squealing.

If the battery continues to not charge properly, or the belt continues to squeal after the initial belt adjustment, replace the belt.

1. Lower the saw head to gain easy access to the alternator area.
2. Turn the key switch to OFF (0) and remove the key.
3. Remove the alternator drive belt cover.
4. Check the belt tension with the Tension Tester (part number 016309) supplied with your Wood-Mizer.
  - 1). Zero out the pounds indicator by sliding the small "O" ring against the yellow flange.
  - 2). Set the deflection indicator to the deflection depth.

---

1. Battery Council International, copyright 1987

3). Place the gauge on the belt at the midpoint between the two pulleys.

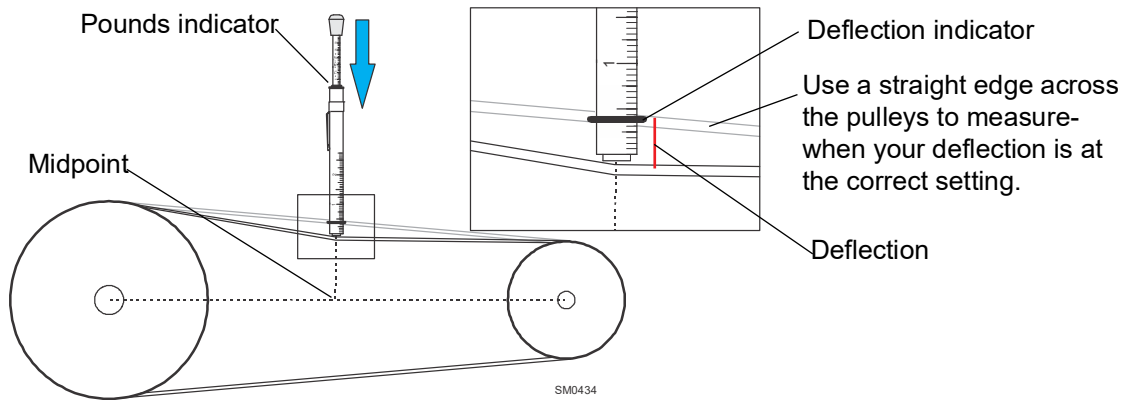

**FIG. 3-0**

4). Press down on the rubber boot while the bottom of the gauge is against the belt.

5. If the belt tension is less than 3/16" with 9 lb. of deflection, tighten the belt as described below:

- 1). Loosen the alternator mounting and adjustment bolts.
- 2). Turn the belt tension adjustment bolt clockwise to tighten the belt, counterclockwise to loosen the belt.
- 3). Tighten the adjustment bolt when the proper belt tension is achieved.

**CAUTION!** Do not overtighten the alternator belt. Damage to the alternator will occur.



6. Tighten the upper and lower mounting bolts.
7. Replace the belt cover.

### 3.7 RPM Adjustments

Check the RPM with a tachometer every **200 HOURS OF OPERATION**.

| Engine | High End RPM | Low End RPM |
|--------|--------------|-------------|
| G25    | 3600         | 1500        |

**TABLE 3-1**

Before checking the RPM, make sure belt and brake strap tensions are correct (See Sawmill Maintenance). Also check oil, fuel, and coolant levels.

Make sure the throttle cable does not affect the engine RPM when the throttle solenoid is disengaged. Make sure the cable is not bent or kinked.

**NOTE:** It is important that the above components are aligned. Proper alignment allows any slack in the cable (when engine is idling) to slide down into the cable spring. This maintains free operation of the cable and prevents the cable from kinking. Make sure the shoulder bolt does not rub against the crankcase vent tube.

1. Start the engine to measure the low-end RPM.
2. Refer to the engine manual to adjust the low-end RPM.
3. Engage the throttle solenoid to throttle the engine and measure the high-end RPM. The high-end RPM is factory-set at 3600. Readjust the throttle cable if necessary to increase or reduce the high-end engine speed.

The throttle cable should be tensioned just enough so that the engine revs as soon as the clutch/brake handle is engaged. NOTE: A properly adjusted throttle will extend the cable spring 1/4" to 3/8" (6.4 - 9.5 mm) when running and have a slight amount of slack in the cable when idling.

### 3.8 Miscellaneous Maintenance

Clean and inspect the spark arrester every 50 hours of operation. Replace if damaged.

Review the manufacturer's engine manual for maintenance intervals.

## SECTION 4 REPLACEMENT PARTS

### 4.1 Fuel Tank Assembly

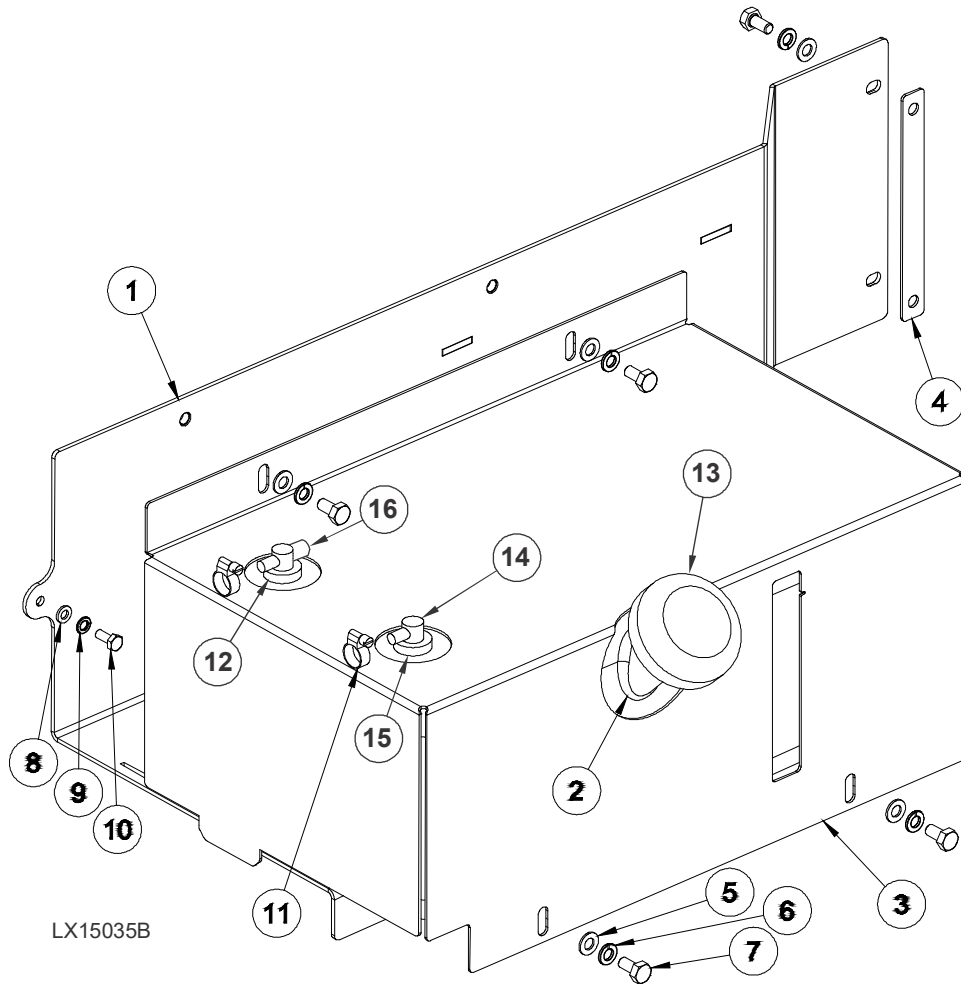

| REF | PART #    | DESCRIPTION                          | COMMENTS | QTY. |
|-----|-----------|--------------------------------------|----------|------|
|     | 011280    | <b>TRAY ASSEMBLY, LX150 GAS TANK</b> |          | 1    |
| 1   | 011283    | Weldment, Fuel Tank Tray             |          | 1    |
| 2   | 103878    | Tank, 5 Gallon Low Pro EPA Fuel      |          | 1    |
| 3   | 103867    | Cover, Fuel Tank                     |          | 1    |
| 4   | 110359    | Plate, LX150 Fuel Tray Spacer        |          | 1    |
| 5   | F05026-4  | Washer, M8 Flat                      |          | 6    |
| 6   | F05011-45 | Washer, M8 Split Lock                |          | 6    |
| 7   | F05004-47 | Bolt, M8x1.25x16mm HH                |          | 6    |
| 8   | F05026-1  | Washer, M6 Flat Class 4              |          | 1    |
| 9   | F05026-2  | Washer, M6 Split Lock                |          | 1    |

# G25

**Replacement Parts**  
*Fuel Tank Assembly*

**4**

| REF | PART #   | DESCRIPTION                         | COMMENTS | QTY. |
|-----|----------|-------------------------------------|----------|------|
| 10  | F05020-7 | Bolt, M6-1 x 14 Class 8 HH          |          | 1    |
| 11  | P649     | Hose Clamp, 7/32in-5/8in            |          | 4    |
|     | 103878   | Tank, 5 Gallon Low Pro EPA Fuel     |          | 1    |
| 12  | 061250   | Grommet, Shut Off                   |          | 1    |
| 13  | 061251   | Gas Cap, LT15                       |          | 1    |
| 14  | 061252   | Valve, Slosh                        |          | 1    |
| 15  | 061253   | Grommet, Slosh Valve                |          | 1    |
| 16  | 074943   | Fitting, Fuel Pick-Up With Shut-Off |          | 1    |
|     | R02423-1 | Hose, Fuel 3/16" EPA 15G CARB (Ft.) |          | 10   |
|     | R02423-2 | Hose, Fuel 1/4" EPA 15G CARB (Ft.)  |          | 10   |

# G25

## 4 Replacement Parts Engine Assembly

### 4.2 Engine Assembly

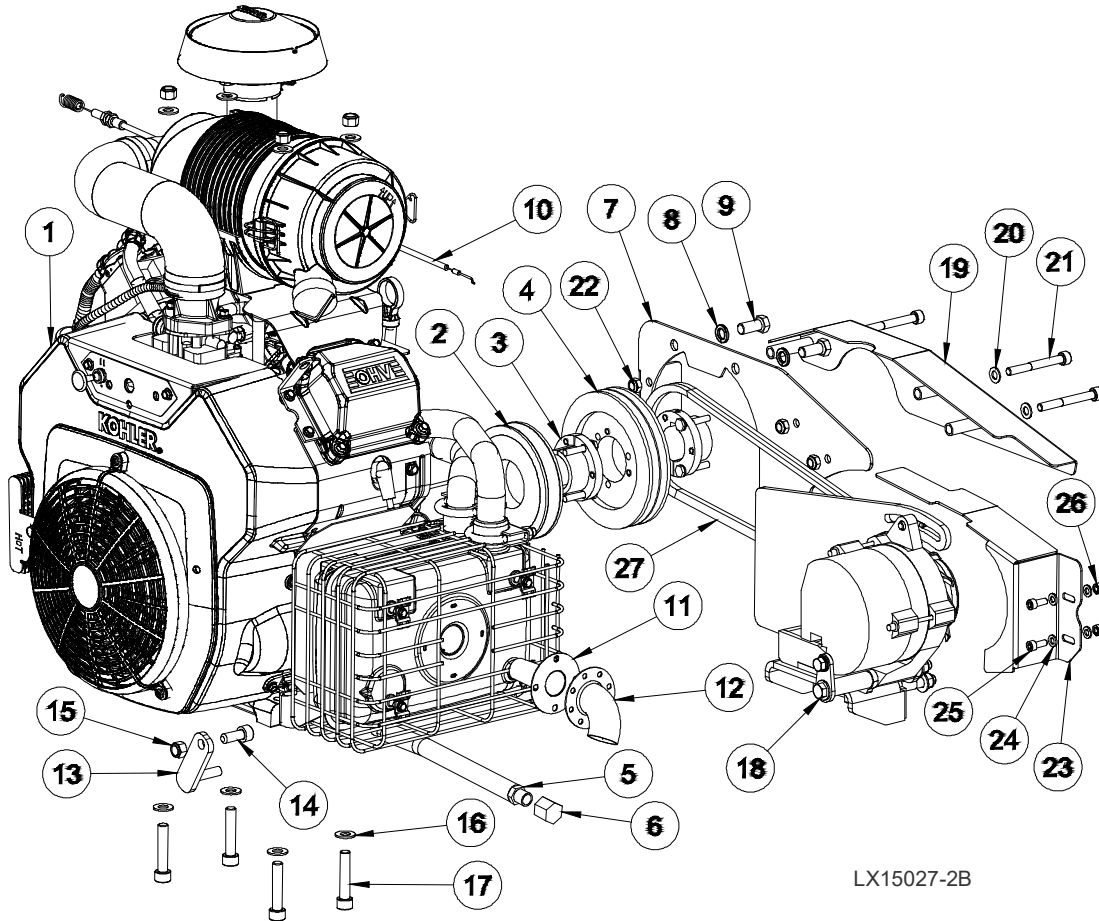

LX15027-2B

| REF | PART # | DESCRIPTION                            | COMMENTS | QTY. |
|-----|--------|--|----------|------|
|     | CEG38  | COVER, ENGINE                          |          | 1    |
|     | 011185 | ENGINE MODULE, LX150G25                |          | 1    |
|     | 011190 | Assembly, LX150 25HP Gas Engine        |          | 1    |
| 1   | 011189 | Engine, 25HP Kohler Gas CH740-3343     |          | 1    |
|     | 036653 | Filter, Kohler Oil 28 050 01-S         |          | 1    |
|     | P12758 | Filter, Kohler Fuel #24-050-13-S       |          | 1    |
|     | 061417 | Plug Spark, Kohler RFI #25 132 14-S    |          | 1    |
|     | 061231 | Pump Electric. Fuel G26 25 755 73-s    |          | 1    |
|     | 046554 | Air Filter, Inner Element #25 083 04-S |          | 1    |

# G25

## Replacement Parts Engine Assembly

**4**

| REF       | PART #     | DESCRIPTION  | COMMENTS | QTY. |
|-----------|------------|--|----------|------|
|           | 046553     | Air Filter, Primary Element #25 083 01-S                               |          | 1    |
|           | 061371     | Assembly, Starter #25 098 21-S   |          | 1    |
|           | 016079     | Module, Ignition Kohler 19hp/25hp Engine #25 584 14-S                  |          | 1    |
|           | 061157     | Kit, Valve Cover w/Lift Pump #24 559 10-S                              |          | 1    |
| <b>2</b>  | 062551     | Sheave, Alternator   |          | 1    |
| <b>3</b>  | 016535     | Bushing, SHx1 7/16   |          | 2    |
| <b>4</b>  | 047742     | Sheave, 3V5.6x2-SH   |          | 1    |
| <b>5</b>  | P10082     | Hose, 3/8NPTx9 5/8 Rubber  |          | 1    |
| <b>6</b>  | P04332     | Cap, 3/8 Pipe Galvanize  |          | 1    |
| <b>7</b>  | 062553     | Plate, LT35 Rear Alt Cover   |          | 1    |
| <b>8</b>  | F05011-48  | Washer, Split Lock 7/16 Zinc   |          | 2    |
| <b>9</b>  | F05007-145 | Bolt, 7/16-14x1 Hex Head Gr5   |          | 2    |
| <b>10</b> | 011365     | Cable, Throttle 23x26 SpringxZ Hook                                    |          | 1    |
| <b>11</b> | 016495     | Spark Arrestor, 1 1/8 Kohler G13-28                                    |          | 1    |
| <b>12</b> | 016496     | Pipe Deflector, Kohler Exhaust   |          | 1    |
| <b>13</b> | 048237     | Support Weldment, LT15G25 Belt   |          | 1    |
| <b>14</b> | F05022-12  | Bolt, M10-1.5 x 25 SHC   |          | 1    |
| <b>15</b> | F05004-270 | Nut, M10-1.50 Hex Nyl Lock   |          | 5    |
| <b>16</b> | F05011-134 | Washer, M10 Flat   |          | 8    |
| <b>17</b> | F05022-36  | Screw, M10-1.5x50 SHC FT BO  |          | 4    |
| <b>18</b> | 110304     | Assembly, LX150 105 Amp Alternator ( <a href="#">See Section 4.3</a> ) |          | 1    |
| <b>19</b> | 062556     | Weldment, LT35 Alt Belt Cover  |          | 1    |
| <b>20</b> | F05026-4   | Washer, M8 Flat  |          | 3    |
| <b>21</b> | F05021-41  | Screw, M8-1.25x70mm SHCS BO  |          | 3    |
| <b>22</b> | F05010-132 | Nut, M8-1.25 Hex Nylock  |          | 3    |
| <b>23</b> | 011149     | Plate, LX150 Alt Cover   |          | 1    |
| <b>24</b> | F05026-1   | Washer, M6 Flat Class 4  |          | 4    |
| <b>25</b> | F05004-206 | Bolt, M6-1.0x16mm SHCS   |          | 2    |
| <b>26</b> | F05010-200 | Nut, M6-1.0 Nylon Lock   |          | 2    |
| <b>27</b> | 011361     | Belt, AX42 Cogged  |          | 1    |

## 4 Replacement Parts Alternator Assembly

### 4.3 Alternator Assembly

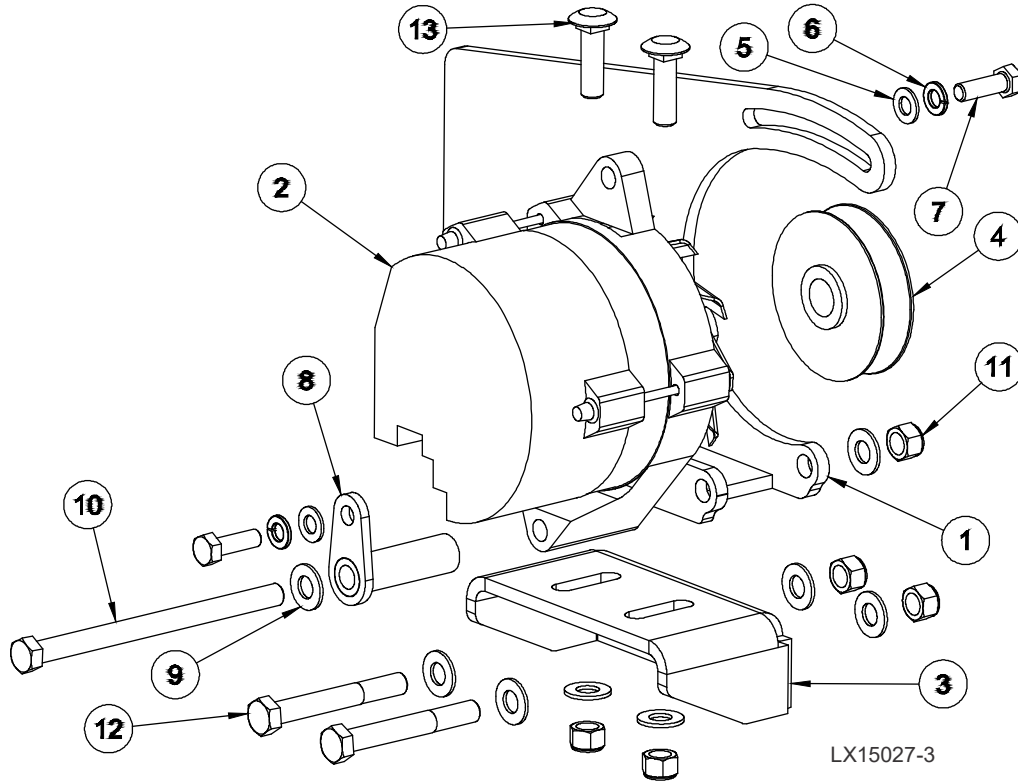

| REF | PART #     | DESCRIPTION                               | COMMENTS   | QTY. |
|-----|------------|---|--|------|
|     | 110304     | <b>ASSEMBLY, LX150 105 AMP ALTERNATOR</b> |  | 1    |
| 1   | 110600     | Weldment, LX150G25 Alternator Mount       |  | 1    |
| 2   | 050287-1   | Alternator, 105A 12V CS130                | Alternator 050287-1 replaced 050287 as of 4/2021, per ECN 37893. | 1    |
| 3   | 110604     | Bracket, Alternator Brkt Mount            |  | 1    |
| 4   | P03806     | Sheave, Alternator                        |  | 1    |
| 5   | F05026-4   | Washer, M8 Flat                           |  | 2    |
| 6   | F05011-45  | Washer, 8mm Split Lock, Zn                |  | 2    |
| 7   | F05004-40  | Bolt, M8x1.25x25 Hex Head FT              |  | 2    |
| 8   | W12761     | Brace Weldment, Alternator                |  | 1    |
| 9   | F05011-134 | Washer, M10 Flat                          |  | 8    |
| 10  | F05022-21  | Bolt, M10-1.5x140 Hex Head Bft            |  | 1    |
| 11  | F05004-270 | Nut, M10-1.50 Hex Nyl Lock                |  | 5    |
| 12  | F05022-15  | Bolt, M10-1.5x75 Hex Head Class 8.8       |  | 2    |
| 13  | F05022-34  | Bolt, M10-1.5x35 Carriage Class 8.8       |  | 2    |



# INDEX

---

## M

maintenance 3-1  
  air cleaner 3-1  
  alternator belt 3-2  
  battery 3-2  
  cooling system 3-1  
  fuel filter 3-2  
  miscellaneous 3-4  
  RPM adjustments 3-3  
  safety 3-1

---

## O

operation 2-1  
  control lights 2-1  
  shutoff 2-2  
  starting 2-1

---

## P

parts list  
  drive assembly 4-5  
  engine assembly 4-1, 4-3  
  motor assembly 4-1, 4-3