

Wood-Mizer[®] Sawmill

Parts Manual

LX150

rev. A1.00 - A2.01



Safety is our #1 concern! Read and understand all safety information and instructions before operating, setting up or maintaining this machine.

December 2018

Form #2274

California
Proposition 65 Warning



WARNING: Breathing gas/diesel engine exhaust exposes you to chemicals known to the State of California to cause cancer and birth defects or other reproductive harm.

Always start and operate the engine in a well-ventilated area.
If in an enclosed area, vent the exhaust to the outside.
Do not modify or tamper with the exhaust system.
Do not idle the engine except as necessary.

For more information go to **www.P65warnings.ca.gov**.



WARNING: Drilling, sawing, sanding or machining wood products can expose you to wood dust, a substance known to the State of California to cause cancer. Avoid inhaling wood dust or use a dust mask or other safeguards for personal protection.

For more information go to **www.P65Warnings.ca.gov/wood**.

Active Patents assigned to Wood-Mizer, LLC

Wood-Mizer, LLC has received patents that protect our inventions which are a result of a dedication to research, innovation, development, and design. Learn more at: woodmizer.com/patents

©2021 Wood-Mizer LLC

Printed in the United States of America, all rights reserved. No part of this manual may be reproduced in any form by any photographic, electronic, mechanical or other means or used in any information storage and retrieval system without written permission from

Wood-Mizer, LLC
8180 West 10th Street
Indianapolis, Indiana 46214

SECTION 1 GENERAL INFORMATION

1-1

1.1	How To Use The Parts List	1-1
1.2	Sample Assembly	1-1

Table of Contents

Section-Page

SECTION 2	BLADE GUIDE ROLLERS & ARM	2-1
2.1	Blade Guide Arm Assembly.....	2-1
2.2	Blade Guide Arm Drive Assembly ECN 37705.....	2-3
2.3	Blade Guide Assembly, Idle Side.....	2-5
2.4	Blade Guide Assembly, Drive Side.....	2-6
SECTION 3	BLADE WHEELS & TENSIONER	3-1
3.1	Blade Drive Assembly	3-1
3.2	Idle Blade Wheel Assembly	3-2
3.3	Blade Tensioner Assembly.....	3-3
SECTION 4	SAW HEAD FRAME	4-1
4.1	Water Lube Assembly	4-1
4.2	Clutch Assembly	4-3
4.3	Brake Assembly.....	4-1
4.4	Saw Head Decals.....	4-3
4.5	Blade Housing Covers & Saw Head Hardware.....	4-5
SECTION 5	CONTROL & BATTERY BOXES	5-1
5.1	Control Box Assembly	5-1
5.2	Control Box Mount & Up/Down Limit Switches	5-3
5.3	Drum Switches	5-4
5.4	Circuit Breakers.....	5-5
5.5	Front Panel Assembly & Harnesses (G25/G38).....	5-6
5.6	Fuse Box.....	5-7
5.7	Battery Box Assembly.....	5-8
SECTION 6	UP/DOWN SYSTEM	6-1
6.1	Mast Pad & Hardware	6-1
6.2	Blade Height Scales & Mast Angles	6-2
6.3	Head Mounting Assembly.....	6-3
6.4	Head Mounting Assembly.....	6-4
6.5	Up/Down Assembly	6-5
SECTION 7	FEED SYSTEM & TRACK ROLLERS	7-1
7.1	Track Rollers and Wipers (Drive Side).....	7-1
7.2	Track Roller And Wipers (Idle Side)	7-3
7.3	Power Feed Assembly	7-5
7.4	Travel Lock Assembly	7-7

Table of Contents

Section-Page

SECTION 8	BED FRAME ASSEMBLY	8-1
8.1	Bed Frame Assembly	8-1
8.2	Bed Section Assembly.....	8-2
8.3	Bed Section Assembly, Front	8-3
8.4	Bed Stop Assembly, Front Left.....	8-4
8.5	Bed Stop Assembly, Rear Left.....	8-5
8.6	Bed Stop Assembly, Front Right.....	8-6
8.7	Bed Stop Assembly, Front Right.....	8-7
SECTION 9	MISCELLANEOUS	9-1
9.1	Replacement Manuals	9-1

SECTION 1 GENERAL INFORMATION

1.1 How To Use The Parts List

- Use the table of contents or index to locate the assembly that contains the part you need.
- Go to the appropriate section and locate the part in the illustration.
- Use the number pointing to the part to locate the correct part number and description in the table.
- Parts shown indented under another part are included with that part.
- Parts marked with a diamond (◆) are only available in the assembly listed above the part.

See the sample table below. Sample Part #A01111 includes part F02222-2 and subassembly A03333. Subassembly A03333 includes part S04444-4 and subassembly K05555. The diamond (◆) indicates that S04444-4 is not available except in subassembly A03333. Subassembly K05555 includes parts M06666 and F07777-77. The diamond (◆) indicates M06666 is not available except in subassembly K05555.

1.2 Sample Assembly				
REF	DESCRIPTION (◆ Indicates Parts Available In Assemblies Only)	PART #	QTY.	
	SAMPLE ASSEMBLY, COMPLETE (INCLUDES ALL INDENTED PARTS BELOW)	A01111	1	
1	Sample Part	F02222-22	1	
	Sample Subassembly (Includes All Indented Parts Below)	A03333	1	
2	Sample Part (◆ Indicates Part Is Only Available With A03333)	S04444-4	1	◆
	Sample Subassembly (Includes All Indented Parts Below)	K05555	1	
3	Sample Part (◆ Indicates Part Is Only Available With K05555)	M06666	2	◆
4	Sample Part	F07777-77	1	

To Order Parts:

- From the continental U.S., call **1-800-525-8100** to order parts. Have your customer number, vehicle identification number, and part numbers ready when you call.
- From other international locations, contact the Wood-Mizer distributor in your area for parts.

SECTION 2 BLADE GUIDE ROLLERS & ARM

2.1 Blade Guide Arm Assembly

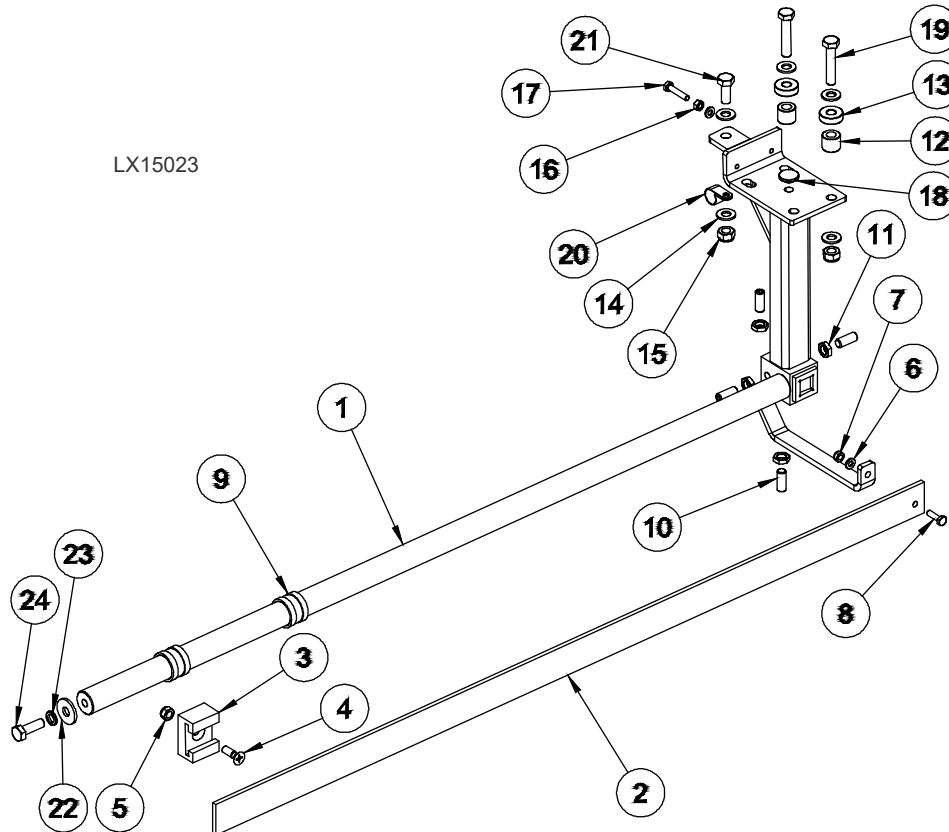

LX15023

REF	DESCRIPTION (◆ Indicates Parts Available In Assemblies Only)	PART #	QTY.
	Arm Assembly, LX150 Blade Guide	524776	1
1	Rod, Blade Guide	524775-1	1
2	Strip, LX150	524773	1
3	Rail, LT15	088305	1
4	Screw, M8x25-5.8-Fe/Zn5 PN/M-82208	F81002-51	1
5	Nut, M8 8 FE/ZN5 PN-85/M-82175	F81032-2	1
6	Washer, 6.4 FE/ZN5 PN-78/M-82005	F81053-1	2
7	Nut, M6-5-B-Fe/Zn5 PN-85/M-82175	F81031-2	1
8	Bolt, M6X20 Hex Head CL8.8	F81001-2	1
9	Bushing, Poland Blade Guide	086684	2
10	Screw, Set M10x1x25 DIN 913	F81015-4	4
11	Nut, M10x1-04-ST-A2E ISO8675	F81033-10	4
12	Bushing, 11/20-17 Zinc	094255-1	2
13	Bearing, 6000-2RSR 10MM Bore	087471	2
14	Washer, Round 10,5 Fe/Zn5 PN-78/M-82005	F81055-1	6
15	Nut, M10 Z	F81033-1	3
16	Nut, M6 8 FE/ZN5 PN-85/M-82144	F81031-1	1
17	Bolt, M6x30-5.6 PN-85/M-82105	F81001-13	1

18	Bushing, Blade Guide	095936	1	
19	Bolt, M10x50-8.8-Fe/Zn5 PN-M/82105.	F81003-4	2	
20	Clamp, 5/8 EMT Coated	010748	1	
21	Bolt, M10-1.5x25 Hex Head Cl 8.8	F81003-11	1	
22	Washer, 11/30-3 CYNK	088787-1	1	
23	Washer, Split Lock Z 10.2 FE/ZN5 PN-77/M82008	F81055-2	1	
24	Bolt, M10x30 5.8 Fe/Zn5 PN-M/82105	F81003-2	1	

2.1 Blade Guide Arm Drive Assembly ECN 37705

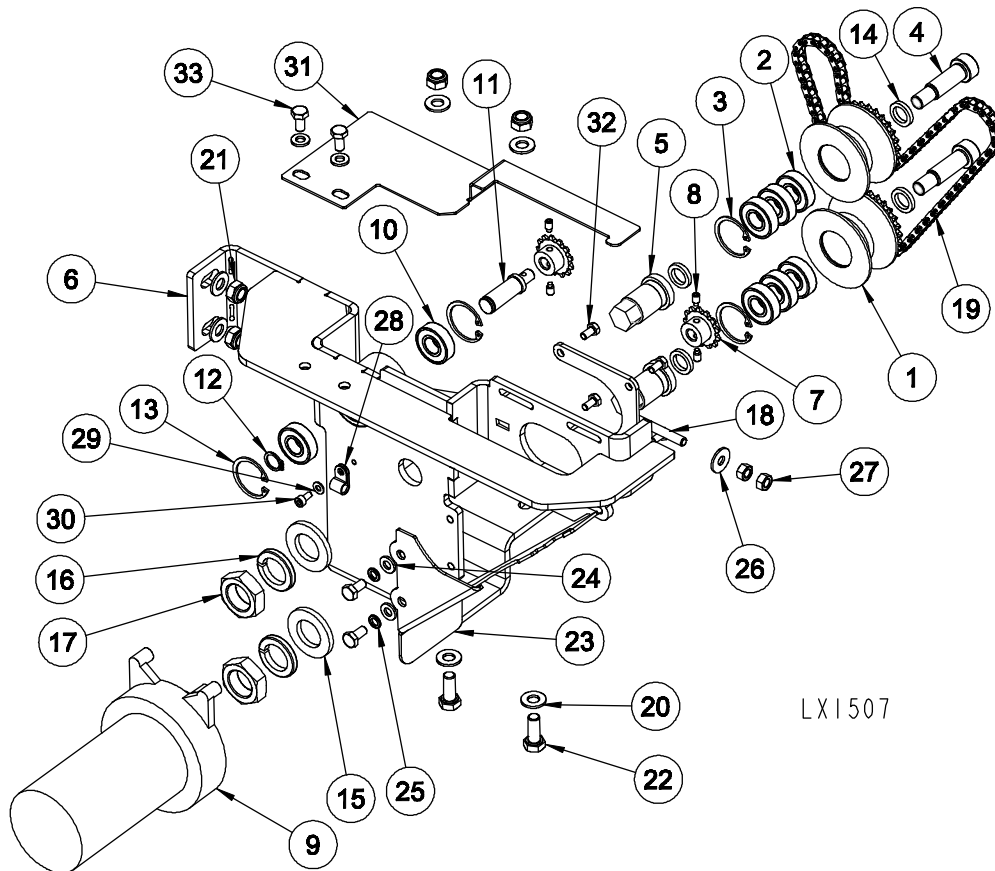

LX1507

REF	DESCRIPTION (◆ Indicates Parts Available In Assemblies Only)	PART #	QTY.
	Guide Assembly, LX150 In/Out Blade	517270	1
	Roller, Complete	517269	2
1	Roller, Sprocket	517253-1	1
2	Bearing, 6001 2RSR	087893	3
3	Ring, Retaining W28	F81090-9	1
4	Bolt, 12/m10x30 12.9 Iso7379	F81003-70	2
5	Bolt, Blade Guide	517257-1	2
6	Plate, Mount Complete	517259-1	1
	Sprocket Assembly, 25b13x.3130	P09970	2
7	Sprocket, 25b13x.3130	P09970-2	1
8	Screw, 10-24x1/4 Shbo Full Dog Pt Set	F05004-274	2
9	Motor, Gear 1/30HP 62RPM 12VDC	P09698-1-CE	1
10	Bearing, 6001 2RSR	087893	3
11	Axle, Idle	517260	1
12	Ring, Spring Z 12	F81090-14	1
13	Ring, Retaining W28	F81090-9	1
14	Washer, 12,3/18-3	517256	4
15	Washer, 21 Fe/zn5 Pn-78/m-82005	F81059-2	2
16	Washer, Split Lock 20.5 Fe/zn5 Pn/m-82008	F81059-1	2
17	Nut, M20x1.5 Hex Jam	F81037-7	2

18	Tensioner, Debarker Motor	089969-1	1	
19	Chain, Blade Guide - Lx100	517267	1	
20	Washer, 8.4 Fe/zn5 Pn-78/m-82005	F81054-1	6	
21	Nut, M8-8-b Hex Nylon Zinc Lock	F81032-2	4	
22	Bolt, M8x20 8.8 Fe/zn5 Pn-85/m-82105	F81002-4	2	
23	Cover, Chain	517268-1	1	
24	Washer, 6.4 Fe/zn5 Pn-78/m-82005	F81053-1	4	
25	Washer, Split Lock Z 6.1	F81053-3	2	
26	Washer, 6.5 Zinc Flat	F81053-11	1	
27	Nut, M6 8 Fe/zn5 Pn-85/m-82144	F81031-1	2	
28	Clamp, Mount Ee63.	F81080-4	1	
29	Washer, 4mm Zinc	F81051-2	1	
30	Bolt, Socket Head M4x8 8.8 Fe/zn5 Pn-87/m-82302	F81011-36	1	
31	Cover, Top	517262-1	1	
32	Bolt, #10-32x1/2 Hex Head	F05004-60	4	
33	Bolt, M6x12 8.8 Fe/zn5 Pn-85/m-82105	F81001-7	4	

2.3 Blade Guide Assembly, Idle Side

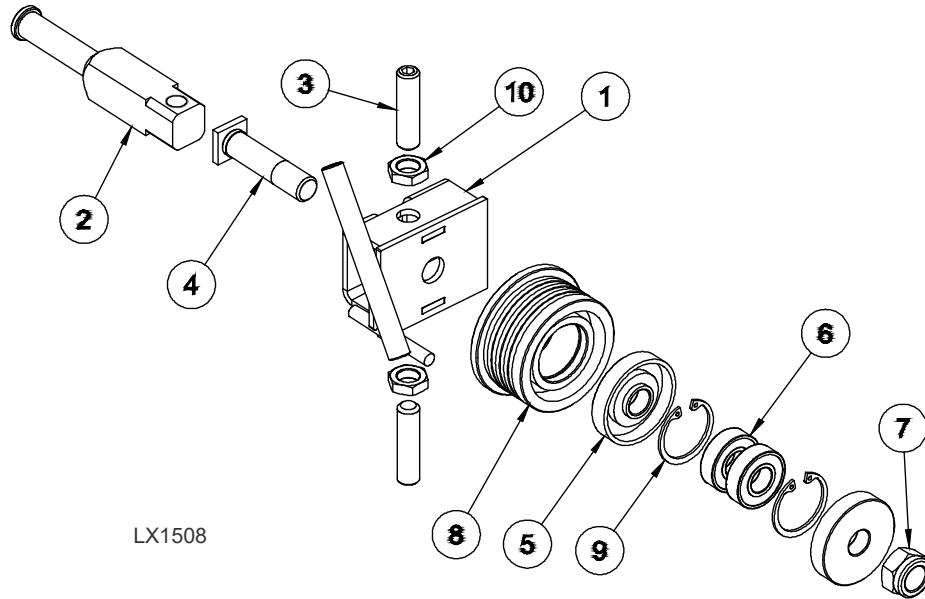

REF	DESCRIPTION (◆ Indicates Parts Available In Assemblies Only)	PART #	QTY.
	Guide Assembly, Poland Blade Idle Side	094683	1
1	Bracket, Blade Guide Idle Side	094681-1	1
2	Shaft, Roller Complete	503588-1	1
3	Screw, Set M10x1x40 Din913 A2-70.	F81015-2	2
	Roller, Blade Guide w/Bearings	087887	1
4	Bolt, Blade Guide	087763-1	1
5	Ring, Blade Guide Roller Zinc	087891-1	2
6	Bearing, 6001 2rsr (Fag, Skf).	087893	2
7	Nut, M12 8 Fe/zn5	F81034-2	1
8	Roller, Blade Guide	087889	1
9	Ring, Retaining W28 Pn/m-85111.	F81090-9	2
10	Nut, M10x1 Iso8675	F81033-10	2

2.4 Blade Guide Assembly, Drive Side

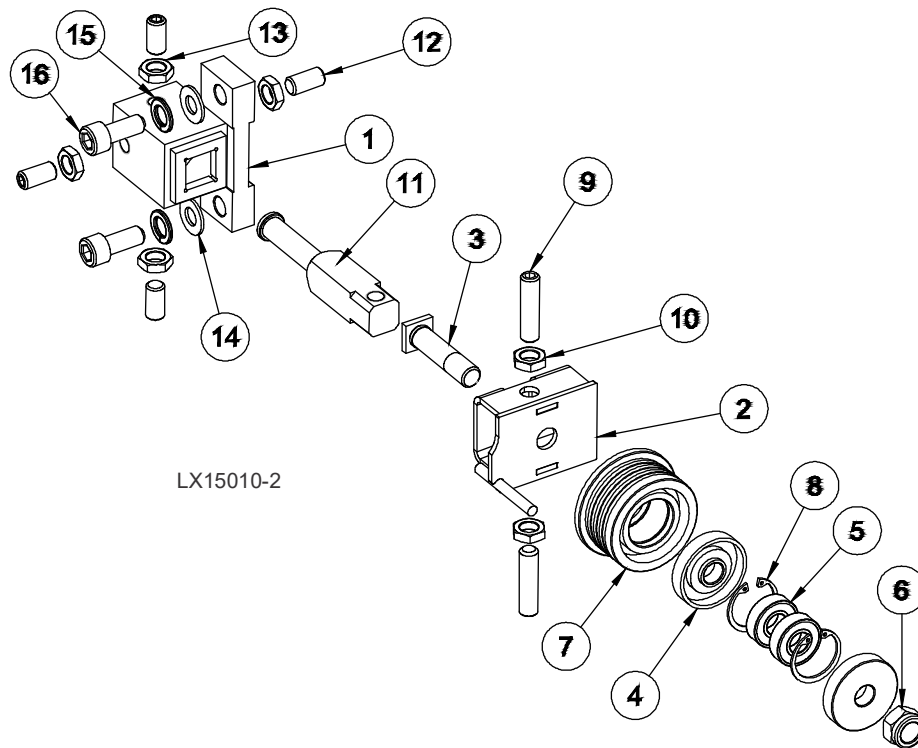

REF	DESCRIPTION (◆ Indicates Parts Available In Assemblies Only)	PART #	QTY.
1	Mount Weldment, Blade Guide	087744_US	1
	Guide Assembly, Poland Blade	094682	1
2	Bracket, Blade Guide Drive Side	094679-1	1
	Roller, Blade Guide w/Bearings	087887	1
3	Bolt, Blade Guide	087763-1	1
4	Ring, Blade Guide Roller Zinc	087891-1	2
5	Bearing, 6001 2rsr (Fag, Skf).	087893	2
6	Nut, M12 8 Fe/zn5	F81034-2	1
7	Roller, Blade Guide	087889	1
8	Ring, Retaining W28 Pn/m-85111.	F81090-9	2
9	Screw, Set M10x1x40 Din913 A2-70.	F81015-2	2
10	Nut, M10x1 Iso8675	F81033-10	2
11	Shaft, Roller Complete	503588-1	1
12	Screw, M10-1x25mm Stainless Set, DIN 913	F81015-4	4
13	Nut, M10x1-04-ST-A2 ISO 8675 Thin	F81033-10	4
14	Washer, M10 Flat	F05011-134	2
15	Washer, 10MM Split Lock	F05011-88	2
16	Bolt, M10-1.5 x 25 SHC	F05022-12	2

SECTION 3 BLADE WHEELS & TENSIONER

3.1 Blade Drive Assembly

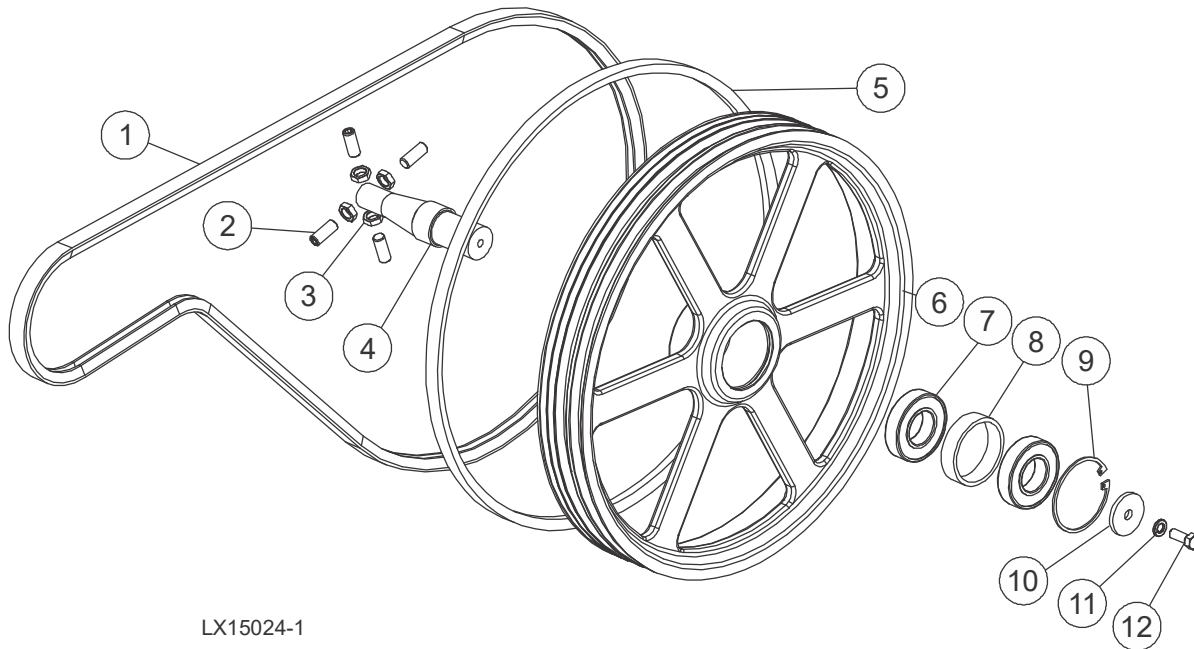

LX15024-1

REF	DESCRIPTION (◆ Indicates Parts Available In Assemblies Only)	PART #	QTY.
1	Belt, 2/3VFL900 Drive	047751	1
2	Screw, M12x1.25x30 DIN913 Stainless Set	F81016-1	4
3	Nut, M12x1.25 DIN439 Thin Stainless	F81034-9	4
4	Shaft, LT15 Drive	014729	1
5	Belt, B-57	P04185	1
	WHEEL ASSEMBLY, LT15 3V DRIVE	036657	1
6	Sheave, 3V LT15 Drive	047702	1
7	Bearing, 6207-2RS, C3, 35x72x17	014811	2
8	Spacer, Drive Bearing LT15	014730	1
9	Ring, 72MM OD Retaining N5002-281	F04254-30	1
10	Washer, LT15 Drive Wheel Ret.	014728	1
11	Washer, 3/8 Split Lock	F05011-4	1
12	Bolt, 3/8-16x1 Gr5 HH	F05007-87	1

3.2 Idle Blade Wheel Assembly

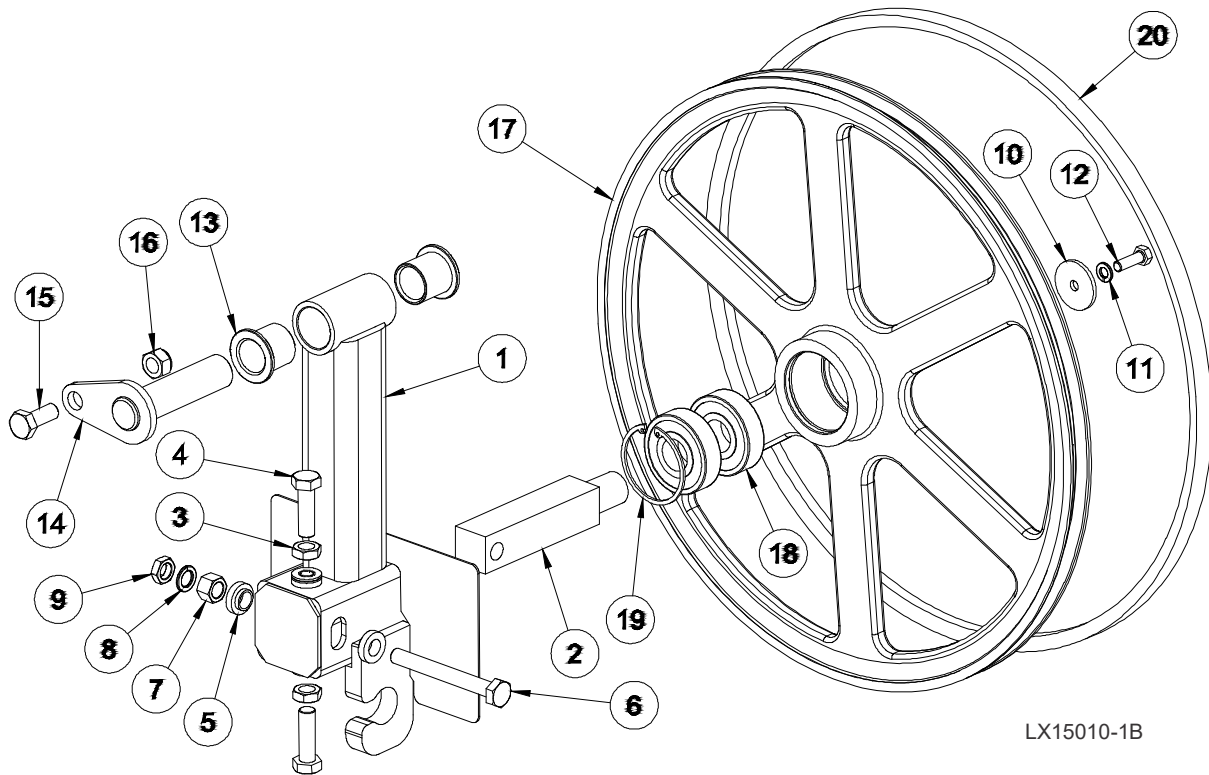

REF	DESCRIPTION (◆ Indicates Parts Available In Assemblies Only)	PART #	QTY.
	Assembly, LX150 Blade Wheel Idler	011267	1
1	Weldment, LX150 Blade Wheel Idler	011268	1
2	Shaft, 30mm Sq Idler	096045	1
3	Nut, M12-1.75 Zinc Jam	F05027-19	2
4	Bolt, M12x1.75x40mm Hex Head FT CL10.9 Zinc	F05004-250	2
5	Spacer, .510x.937x.34	S04253	2
6	Bolt, M12x1.25x100 Gr8.8 Hex Head Full Thread	F81004-41	1
7	Nut, M12x1.25 8.8 Hex Zinc	F81034-8	1
8	Washer, 12MM Split Lock	F05011-123	1
9	Nut, M12x1.25 8.8 Hex Zinc Thin	F81034-5	1
10	Washer, .313x1.5x.125	S08220	1
11	WASHER, 8MM SPLIT LOCK, ZN	F05011-45	1
12	Bolt, M8x1.25x25 Hex Head FT	F05004-40	1
13	Bushing, 1 IDx1-1/4 ODx1-1/4 FI	P109	2
14	Pin Weldment, Side Support	042232	1
15	Bolt, M12x1.75x30mm Hex Head Znc	F05008-175	1
16	Nut, M12x1.75 Hex Nylock	F05010-209	1
	Sheave Assembly, 19 Idler	A08218	1
17	Sheave, 18.62 Idler	P08125	1
18	Bearing, .9843x2.4409x.6693	P08066	2
19	Snap Ring, 2 7/16 IR Beveled	F04254-21	1
20	BELT, B-57	P04185	1

3.3 Blade Tensioner Assembly

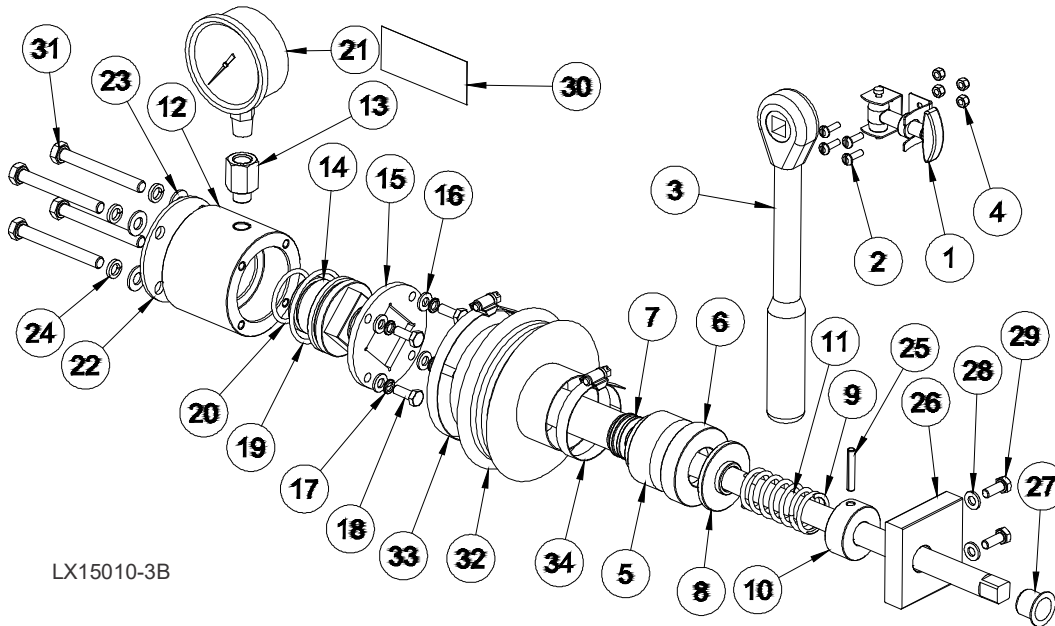

REF	DESCRIPTION (◆ Indicates Parts Available In Assemblies Only)	PART #	QTY.
1	Latch, Tool Retaining	011360	1
2	Screw, 4mx12 CrSI Round Head Machine	F05004-74	4
3	Tool, Blade Tensioning	091620	1
4	Nut, M4-.7 Class 8 Nylock	F05027-8	4
	Tensioner, LX150 Blade	510640	1
5	Housing, Round	510635	1
6	Ring, Round	510634-1	1
7	Bearing, 51103	086675	1
8	Washer, Blade Tensioner	510633-1	1
9	Spring, 60x23x3	088992	1
10	Bushing, 16/38-20 22.5-4 Zinc	510636-1	1
11	Bolt, Blade Tensioner Zinc	510650-1	1
	Cylinder, Complete	510641	1
	Cylinder Assembly, Reduction	510657-1	1
12	Cylinder	510637	1
13	Fitting, Z-m12x1/w-1/4npt	513280	1
14	Piston, Blade Tensioner	510638	1
15	Plate, Tensioner	510490-1	1
16	Washer, 6.4 FE/ZN5 PN-78/M-82005	F81053-1	4
17	Washer, Split Lock Z 6.1	F81053-3	4
18	Bolt, M6x16-8.8-FE/ZN5 PN-M/82105	F81001-15	4
19	Ring, 46.2x3	510646	1
20	Ring, 32.2x3	510647	1
21	Gauge, Oil Pressure 200 Bar (3000psi)	505176	1
22	Cover, Tensioner	510642-1	1
23	Washer, 8.4 FE/ZN5 PN-78/M-82005	F81054-1	4

24	Washer, Split Lock M8 Fe/zn5 Pn-m/82008	F81054-4	4	
25	Pin, Roll 5x30 FE/ZN5 PN/M-85023.	F81044-21	1	
26	Bracket, Blade Tensioner	096730	1	
27	Bushing, GFM-1618-17	089589	1	
28	Washer, 6.4 FE/ZN5 PN-78/M-82005	F81053-1	2	
29	Bolt, M6x16-8.8-FE/ZN5 PN-M/82105	F81001-15	2	
30	Decal, Pressure Settings	510643	1	
31	Bolt, M8x70 8.8 Hex Head Zinc	F81002-71	4	
	Cover, Blade Tensioner Complete	515050	1	
32	Cover, Blade Tensioner	515051	1	
33	Clamp, 70-80 Mm.	F81095-5	1	
34	Clamp, 40-60 Mm.	F81095-4	1	

SECTION 4 SAW HEAD FRAME

4.1 Water Lube Assembly

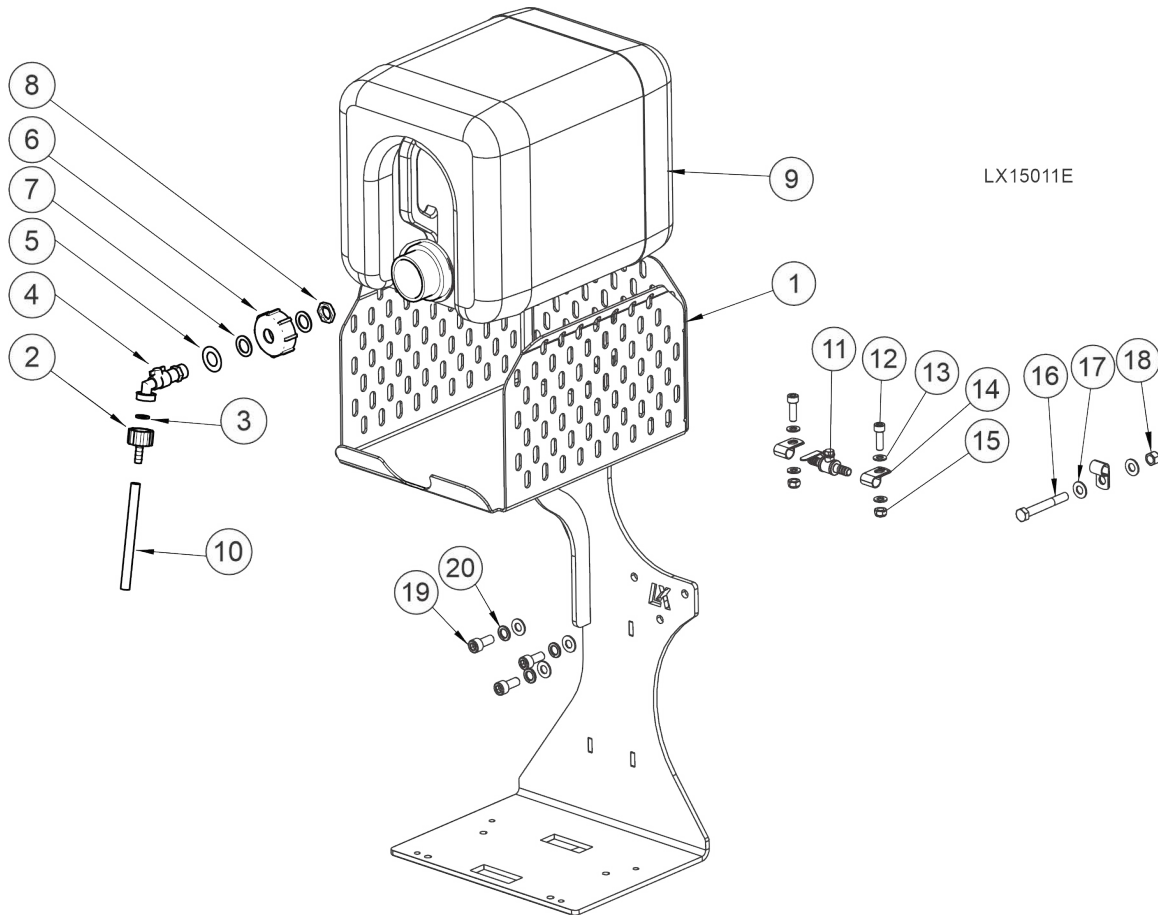

REF	PART #	DESCRIPTION	COMMENTS	QTY.
	011231	Tray Assembly, LX150 Water Bottle		1
1	011171	Weldment, Battery/Water Mounting		1
	550787	Assembly, Water Bottle		1
2	550777	Fitting, G3/4" X 10mm Hose Barb		1
3	550778	Gasket, 1/2 (Batard)		1
4	550776	Fitting, Water Lube Shutoff Valve		1
5	530841	Shim, 21/37-1		1
6	550785	Cap. Water Bottle		1
7	550780	O-ring, 27x20x1.5		2
8	550779	Gland Nut, 1/2 Npt		1
9	513866	Bottle, Water		1

REF	PART #	DESCRIPTION	COMMENTS	QTY.
10	R01885	Hose, Water Lube Stock		1
11	065635	Valve, 1/4Turn Ball 3/8 Hose Barbs		1
12	F05021-33	Screw, M8-1.25x25 SHC BO		2
13	F05026-4	Washer, M8 Flat		4
14	P07584	Clamp, 1/2EMT Coated		3
15	F05010-132	Nut, M8-1.25 Hex Nylock		2
16	F05022-15	Bolt, M10-1.5x75 Hex Head Class 8.8		1
17	F05011-134	Washer, M10 Flat		5
18	F05004-270	Nut, M10-1.50 Hex Nyl Lock		1
19	F05022-12	Bolt, M10-1.5x25 SHC		3
20	F05011-88	Washer, 10mm Split Lock		3

3.3 Clutch Assembly

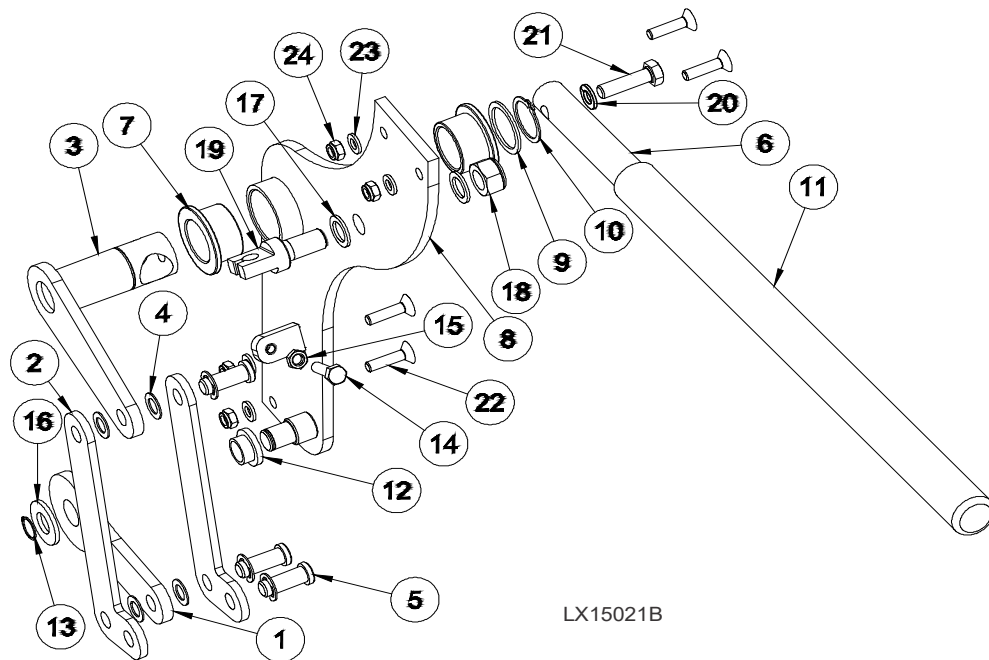

REF	DESCRIPTION (◆ Indicates Parts Available In Assemblies Only)	PART #	QTY.
	Assembly, LX150 Clutch	011219	1
1	Plate, LX150 Clutch Pivot Arm	011215	1
2	Plate, LX150 Clutch Engagment Arm	011214	2
3	Weldment, LX150 Throttle Engagement	011132	1
4	Washer, 3/8 ID 5/8 OD .032 Thick Nylon	033444	4
5	Pin, 3/8x13/16 Clevis, Stainless	F05012-154	3
6	Handle, LX150 Clutch Engagment	011217	1
7	Bushing, 1x1 1/4x3/4 Flg Bronze	P737	2
8	Weldment, LX150 Clutch Hub	011193	1
9	Shim, 1 ID 1-1/4 OD	076037	1
10	Ring, 1 OR	F04254-15	1
11	Grip, Handle	028390	1
12	Bushing, 1/2IDx5/8ODx3/8 Long FI	049007	1
13	Ring, Shaft 1/2 In, Retaining	F04254-18	1
14	Bolt, M6-1 x 25 Class 8 Hex Head	F05020-33	1
15	Nut, M6x1 Metric Jam	F05010-226	1
16	Washer, 1/2 SAE Flat	F05011-2	1
17	Washer, 1/2x3/4x1/16 Nylon	P05251-1	2
18	Nut, M12x1.75 Hex Nylock	F05010-209	1
19	Bolt, LX150 Throttle Pivot	011235	1
20	Washer, 8mm Split Lock, Zn	F05011-45	1
21	Bolt, M8-1.25x30mm Hex HeadC FT	F05021-11	1
22	Screw, M6x1x25mm FHS	F05004-266	4
23	Washer, M6 Flat Class 4	F05026-1	4
24	Nut, M6-1.0 Nylon Lock	F05010-200	4
	See your specific engine manual for clutch cable P/N		

4.2 Brake Assembly

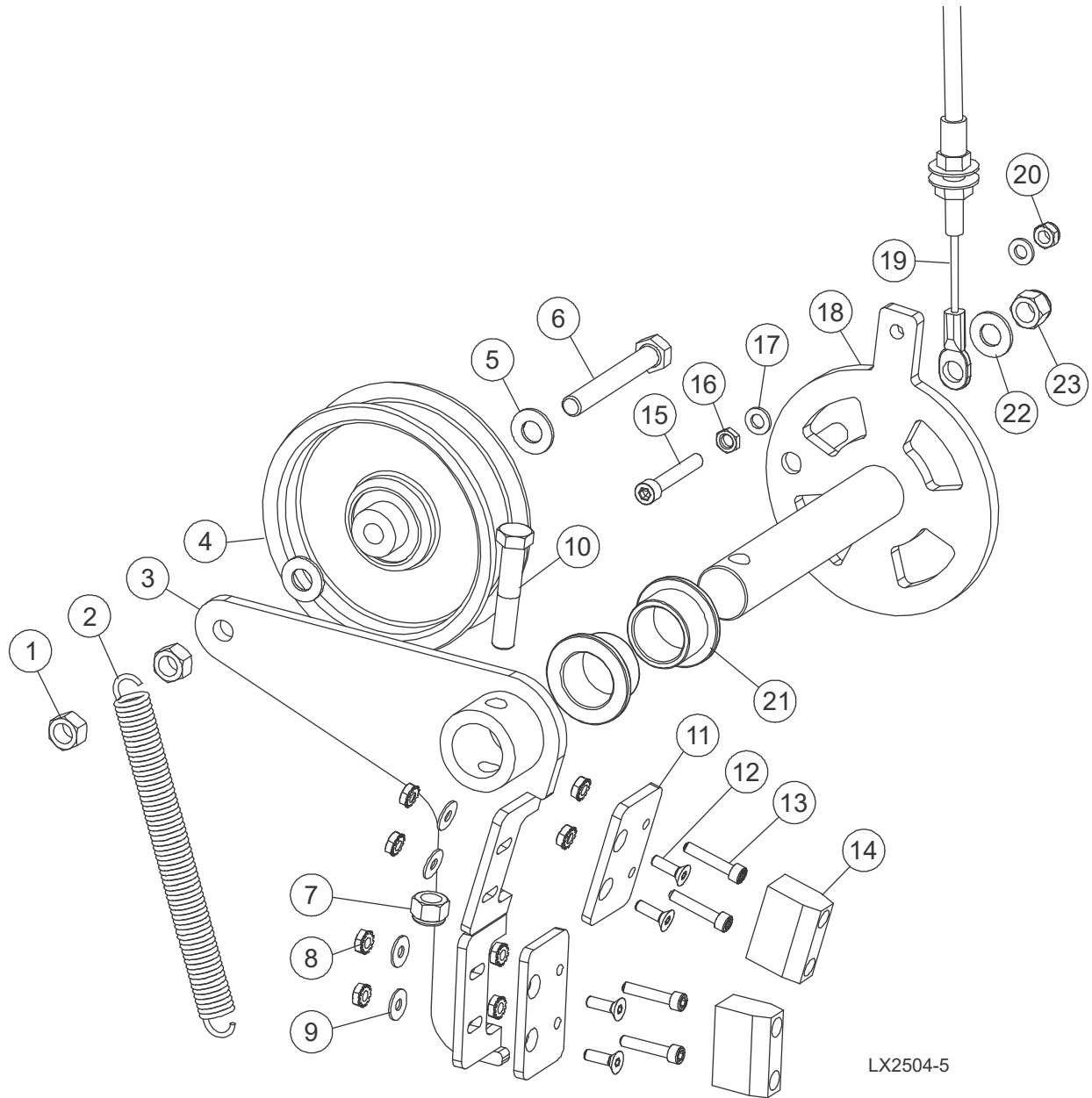

REF	DESCRIPTION (♦ Indicates Parts Available in Assemblies Only)	PART #	QTY.
	Assy, Brake/Clutch	065874	
1	Nut, 3/8-16 Swaged Lock	F05010-25	2
2	Spring, Idler Arm LT15/D/E/G	034810	1
3	Weldment, Clutch/Brake Arm	065873	1
4	Idler, 4" O.D.x 3/8 Bore	034602	1
5	Washer, 3/8 Flat SAE	F05011-3	2
6	Bolt, 3/8-16x2 3/4 FT Gr5	F05007-230	1
7	Nut, 3/8-16 Hex Nyloc	F05010-10	1
8	Nut, #10-24 Keps->	F05010-14	8

REF	DESCRIPTION (♦ Indicates Parts Available in Assemblies Only)	PART #	QTY.	
9	Washer, #10 SAE Flat	F05011-18	4	
10	Bolt, 3/8-16X2 HH GR5	F05007-124	1	
11	Plate, Brake Adjustment	065872	2	
12	Screw, 10-24x5/8 FSHC BO	F05004-282	4	
13	Bolt, 10-24x1 BO SHC	F05004-2	4	
14	Block, LT15 Brake	016488	2	
15	Bolt, M6-1.0x40mm SHCS	F05004-284	1	
16	Nut, M6x1 Metric Jam	F0501-0-226	1	
17	Washer, M6 Flat Class 4	F05026-1	2	
18	Weldment, LX150 Clutch/Brake Pivot	011187	1	
19	Cable, .140"x69" Throttle	011131	1	
20	Nut, M6-1.0 Nylon Lock	F05010-200	1	
21	Bushing, 1x1 1/4x3/4 Flg Bronze	P737	2	
22	Washer, 3/8 Flat SAE	F05011-3	1	
23	Nut, 3/8-16 Hex Nyl Lock	F05010-10	1	

4.4 Saw Head Decals

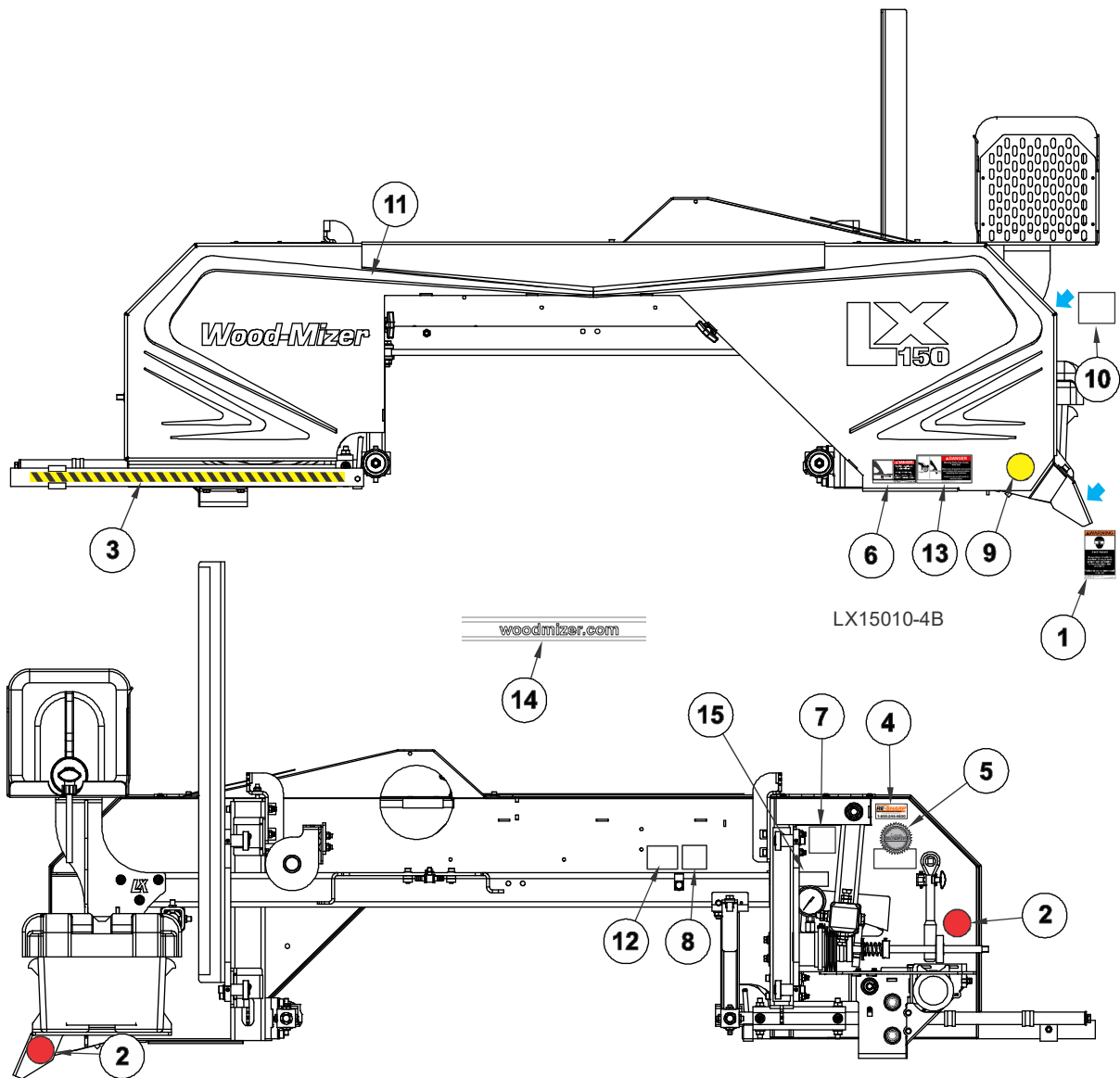

REF	DESCRIPTION (◆ Indicates Parts Available In Assemblies Only)	PART #	QTY.
1	DECAL, SAWDUST CHUTE WARNING	P11754	1
2	DECAL, RED REFLECTIVE 2" ROUND	P07452	2
3	DECAL, BLADE GUIDE ARM STRIPE	O15849	1
4	DECAL, BLADE RESHARP INFO	P12879	1
5	DECAL, WOOD-MIZER QUALITY & INFORMATION	079278	1
6	DECAL, BLADE DANGER	S11752	1
7	DECAL, BLADE ALIGNMENT	P11789	1
8	DECAL, TENSION SCREW	P11790	1
9	DECAL, AMBER REFLECTIVE 2" ROUND	P07453	1
10	DECAL, BUILT IN THE USA	074008	1
11	DECAL, LX150 BLADE COVER	O11141	1

12	DECAL, HYDRAULIC BLADE TENSION CAUTION	P10147	1	
13	DECAL, BLADE COVERS DANGER	033254	2	
14	DECAL, WHITE WOODMIZER.COM (LOCATED ON POWER FEED TUBE)	107170	1	
15	DECAL, TENSION	128179	1	

4.5 Blade Housing Covers & Saw Head Hardware

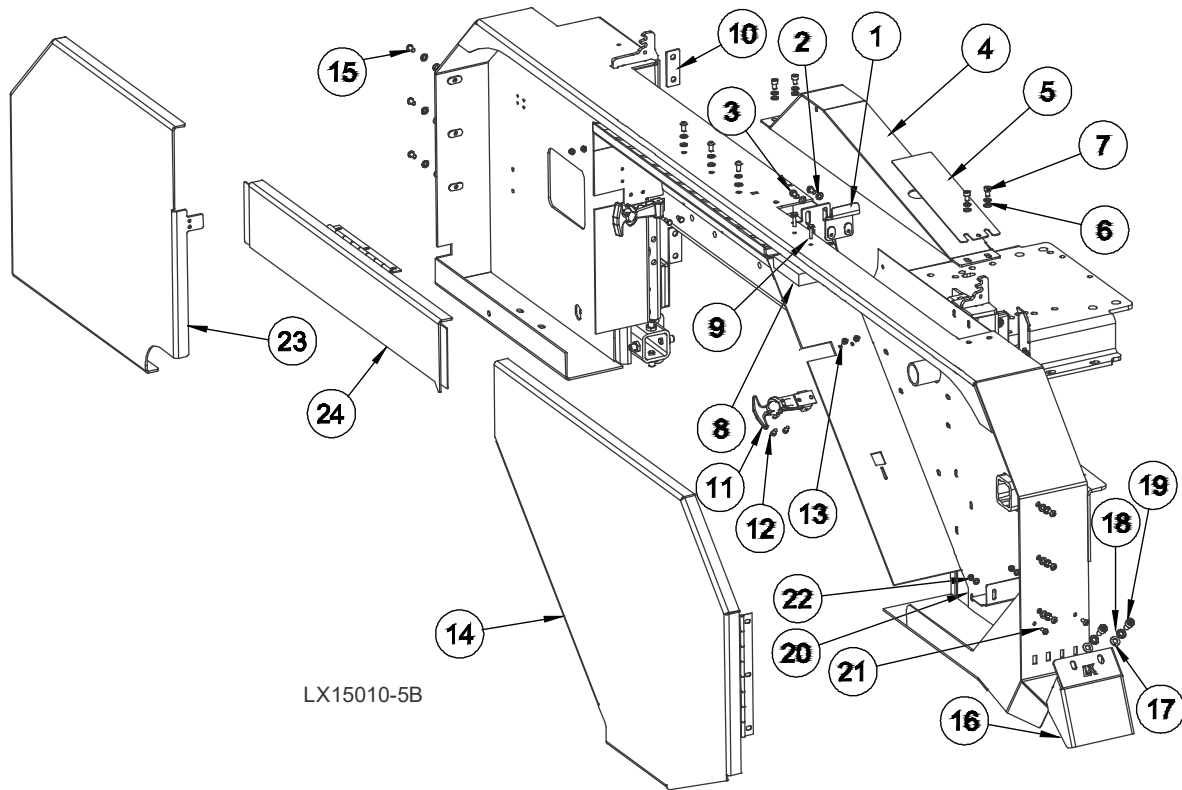

REF	DESCRIPTION (◆ Indicates Parts Available In Assemblies Only)	PART #	QTY.
1	BRACKET WELDMENT, LX150 BELT ENHANCE	011242	1
2	WASHER, M6 FLAT CLASS 4	F05026-1	15
3	SCREW, M6-1X12 HEX HEADC FT	F05005-99	2
4	WELDMENT, LX150 TOP BELT COVER	076656	1
5	PLATE, BELT GUARD COVER	074546	1
6	WASHER, M6 SPLIT LOCK	F05026-2	13
7	SCREW, M6-1 X 10 SHC	F05020-19	4
8	PAD, BLADE VIBRATION	015844	1
9	SCREW, #10X3/4 SL HEX WAS HEAD SCR	F05015-33	2
10	SHIM PLATE, MAST ROLLERS	110599	2
11	LATCH, FLEXIBLE DRAW	014829	2
12	SCREW, M5-0.8X16MM SHCS SS	F05004-259	4
13	NUT, M5-.8 CLASS 8 HEX NYLOC	F05027-3	6
14	WELDMENT, COVER RIGHT	117076 ¹	1
15	SCREW, M6-1.0 X 12MM BHCS BLACK OXIDE	F05004-275	9
16	PLATE, LX150 SAWDUST DEFLECTOR	011243	1
17	WASHER, M8 FLAT	F05026-4	2
18	WASHER, M8 SPLIT LOCK	F05011-45	2
19	SCREW, M8-1.25 X 16 SHC	F05021-10	2
20	PLATE, SAWDUST DIVERTER	108060	1
21	SCREW, M5-.8X12MM BHCS	F05020-55	2
22	WASHER, 5.3 FE/ZN5	F81052-1	2

23	WELDMENT, COVER LEFT	011416	1	
24	WELDMENT, LX150 CENTER COVER	110992	1	

¹ Cover Weldment 011074 was replaced by Cover Weldments 117076, 011416, and 110992 on 5/6/2019.

SECTION 5 CONTROL & BATTERY BOXES

5.1 Control Box Assembly

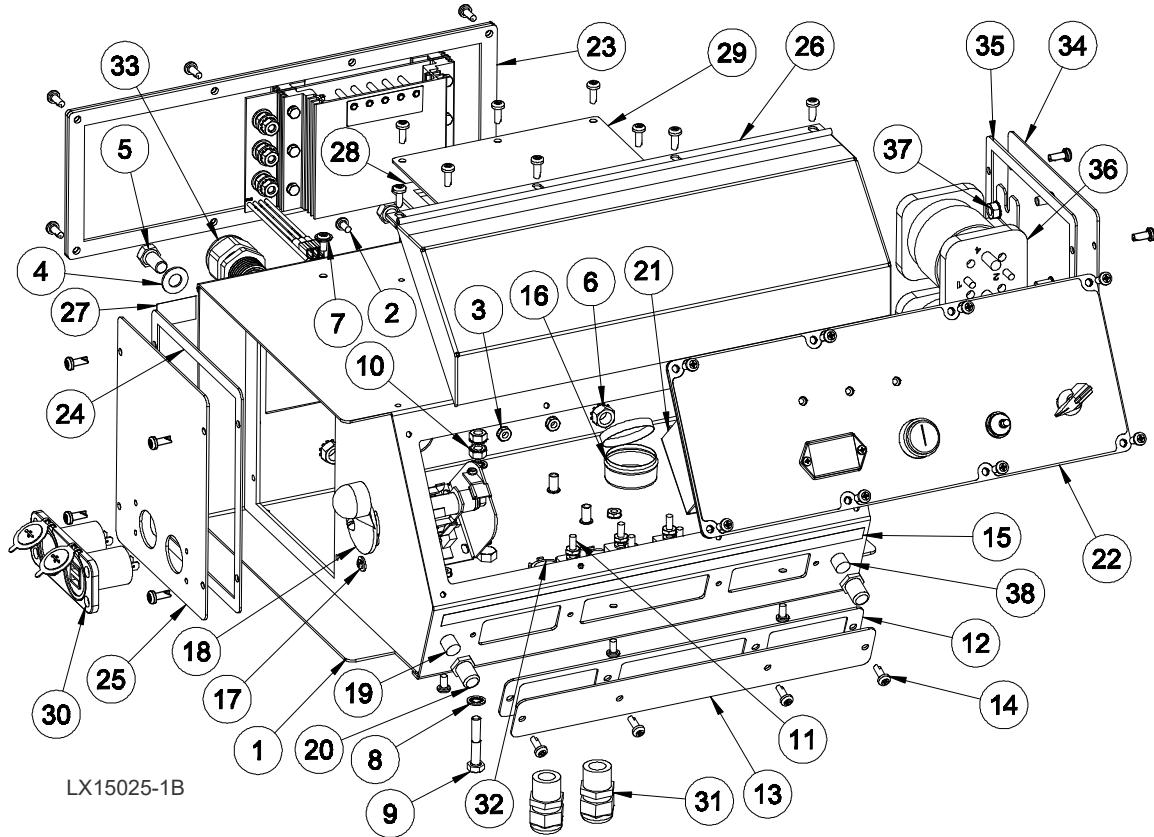

REF	DESCRIPTION (◆ Indicates Parts Available In Assemblies Only)	PART #	QTY.
	OPERATOR ASSEMBLY, LX150G25	073588	1
1	Box Weldment, Control	011271	1
2	Bolt, #10-24x3/8 CrSI PH	F05004-3	5
3	Nut, #10-24 Keps	F05010-14	9
4	Washer, 3/8 Flat SAE	F05011-3	2
5	Bolt, 3/8-16x3/4 Hex Head Gr2	F05007-27	2
6	Nut, 3/8-16 Keps	F05010-19	2
7	Bolt, #10-24x3/8 CrSI Washer Pan Head	F05004-148	4
8	Washer, 1/4 Int Star Heavy Duty	F05011-69	2
9	Bolt, 1/4-20x1 1/2 Hex Head FT	F05005-31	1
10	Nut, 1/4-20 Keps	F05010-9	2
11	Breaker Assy, LX150/LX250 Control (See Section 5.4)	114030	1
12	Gasket, Circuit Breaker Panel	015266	1
13	Panel, Circuit Breaker	015376	1
14	Bolt, #10-24x1/2 Ph Pan Hd, Type 23	F05015-17	40
15	Decal, Circuit Breaker ID (2010 Std)	069349	1
16	Grease, Drum Switch	A20463	1
17	Washer, #8 SAE Flat Zinc	F05011-41	6

18	Switch Assembly Fwd/Rev Drum Std 2005 ((See Section 5.3))	052152	1	
19	Breaker, 40A Manual Reset Panel Mount	051981	1	
20	Boot, Circuit Breaker	021253	2	
21	Switch Assembly, '10 Std Up/Dn Drum ((See Section 5.3))	069350	1	
22	Panel Assembly, LX150 Front ((See Section 3.5))	073673	1	
23	Panel Assembly, Consolidated P/F CTRL 97+	073578	1	
24	Gasket, Side Panel	015274	2	
25	Plate, Control Box Side	011273	1	
26	Cover Weldment	015304	1	
27	Decal, Circuit Breaker ID (Auto Clutch)	024366	1	
28	Gasket, Control Box Cover	065376	1	
29	Plate, Control Box Cover	065375	1	
30	USB Socket, Accessory	011274	1	
31	Connector, 1/2" NPT .17-.47	051299	2	
32	Nut, 1/2 NPT Connector Lock	E20461	2	
33	Connector, 3/4" NPT .450-.709	053479	3	
	Panel Assembly, Solenoid Up/Down 97	015425	1	
34	Panel Weldment, Side	015307	1	
35	Gasket, Side Panel Control 97	015274	1	
36	Solenoid, 200A 12V DPST	016370	2	
37	Nut, 1/4-20 Keps	F05010-9	3	
38	Breaker, 50A Manual Reset Panel Mount	021256	1	

5.2 Control Box Mount & Up/Down Limit Switches

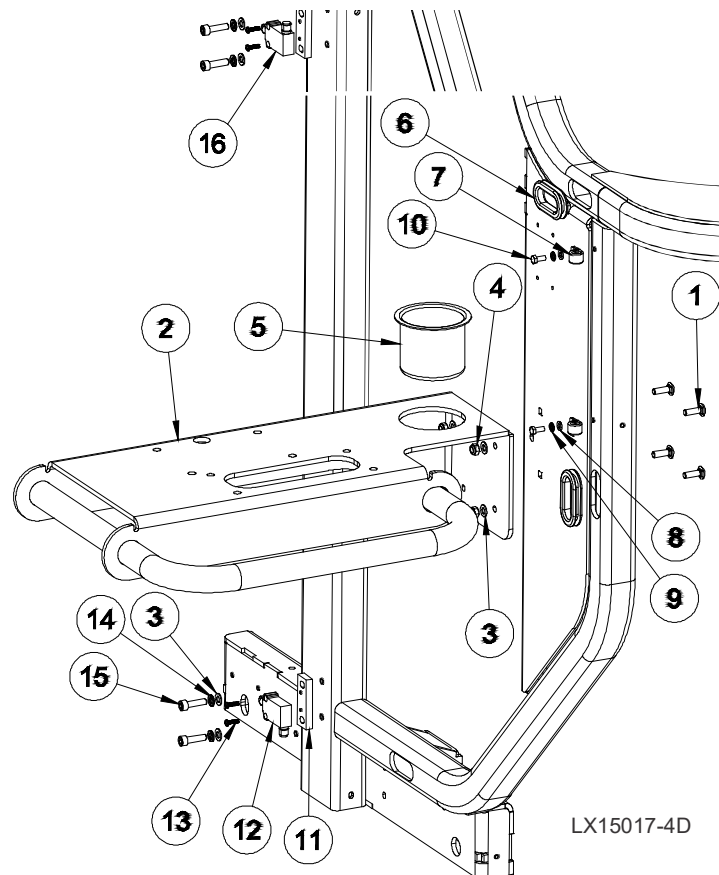

REF	DESCRIPTION (◆ Indicates Parts Available In Assemblies Only)	PART #	QTY.
1	BOLT, M8-1.25X25 CARRIAGE CLASS 8.8	F05021-17	4
2	WELDMENT, LX150 CONTROL MOUNT	011065	1
3	WASHER, M8 FLAT	F05026-4	8
4	NUT, M8-1.25 HEX NYLOCK	F05010-132	4
5	CUP HOLDER	011382	1
6	GROMMET, 1-3/4" ID X 2" HOLE RUBBER	011269	5
7	CLAMP, 1/2 IDX9/32 MOUNTING HOLE COATED	011295	2
8	WASHER, M6 FLAT CLASS 4	F05026-1	2
9	WASHER, M6 SPLIT LOCK	F05026-2	2
10	BOLT, M6-1 X 14 CLASS 8 HEX HEAD	F05020-7	2
11	BRACKET, LIMIT SWITCH MOUNTING	011375	2
12	SWITCH, LIMIT METAL ROLLER STRAIGHT CONN	114013	1
13	SCREW, M4-.7X15 PAN HEAD PHILLIPS	F05020-26	4
14	BOLT, M8-1.25X16 HEX HEAD ZINC	F05004-47	4
15	SCREW, M8-1.25 X 30 SHC	F05021-1	4
16	SWITCH, 90× LIMIT	011376	1

5.3 Drum Switches

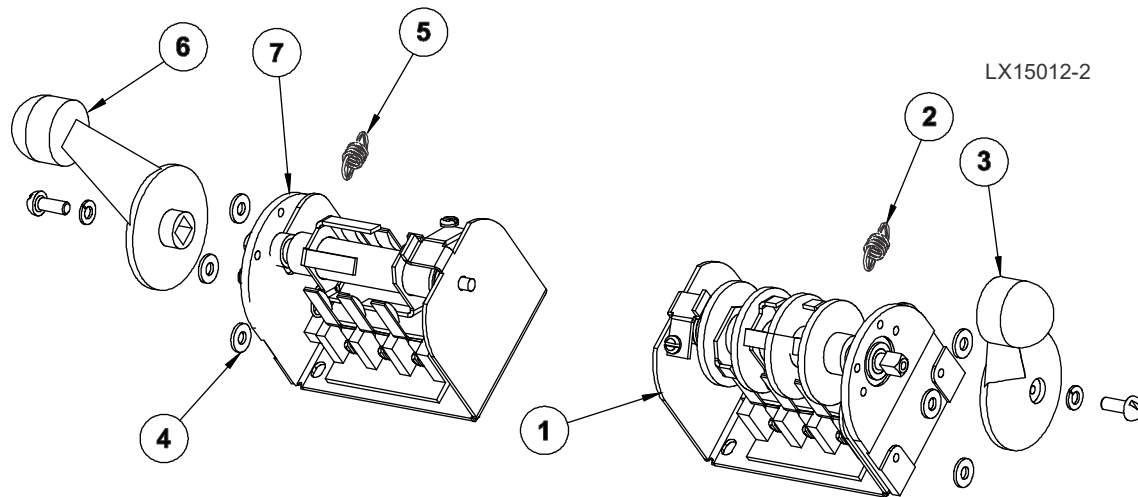

REF	DESCRIPTION (◆ Indicates Parts Available In Assemblies Only)	PART #	QTY.	
	SWITCH ASSEMBLY, UP/DOWN DRUM	E20440	1	
1	Switch, S12 Bulk Drum	E20440-B	1	◆
2	Spring, Drum Switch	P12570	1	
3	Handle, Drum Switch Replacement	P12500	1	
	SWITCH ASSEMBLY, POWER FEED DRUM	E20439	1	
4	Switch, S11 Bulk Drum	E20439-B	1	◆
5	Spring, Drum Switch	P12570	1	
6	Handle, Drum Switch Replacement	P12500	1	
7	WASHER, #8 SAE FLAT	F05011-41	6	

5.4 Circuit Breakers

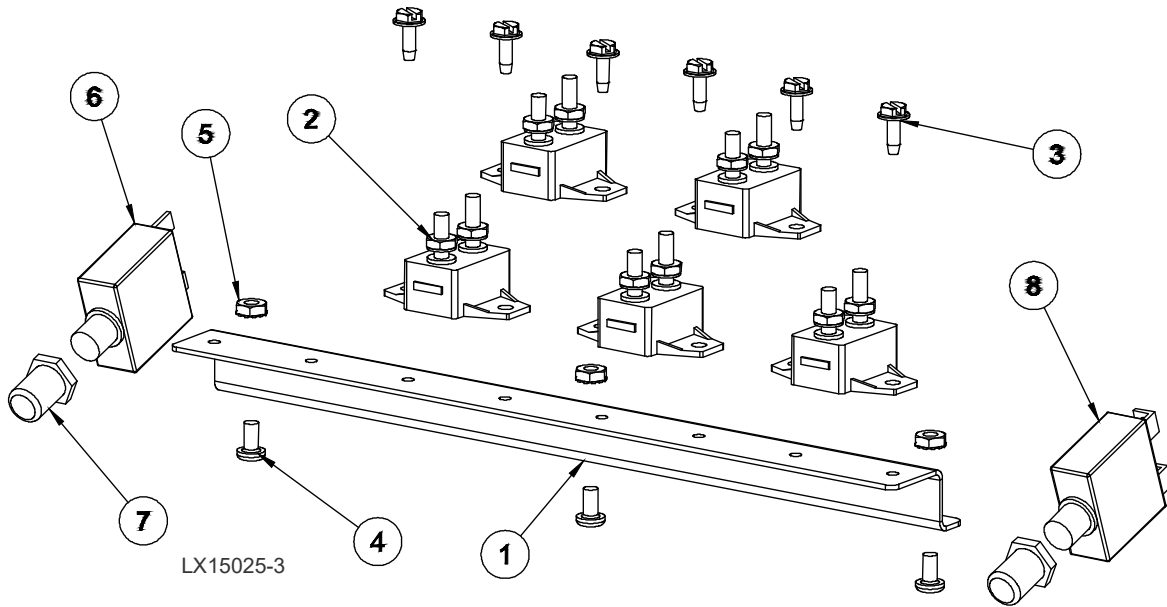

REF	DESCRIPTION (◆ Indicates Parts Available In Assemblies Only)	PART #	QTY.
	BREAKER ASSEMBLY, '98 SAWMILL CONTROL	015621	1
1	Rail, Circuit Breaker Self Tap	052826	1
2	Breaker, 15A Manual Reset	E20430	5
3	Bolt, #10-24x1/2 Self Tap	F05015-7	6
4	BOLT, #10-24X3/8 CRSL PH	F05004-3	3
5	NUT, #10-24 KEPS	F05010-14	3
6	BREAKER, 40A MANUAL RESET PANEL MOUNT	051981	1
7	BOOT, CIRCUIT BREAKER	021253	2
8	BREAKER, 50A MANUAL RESET PANEL MOUNT	021256	1

3.5 Front Panel Assembly & Harnesses (G25/G38)

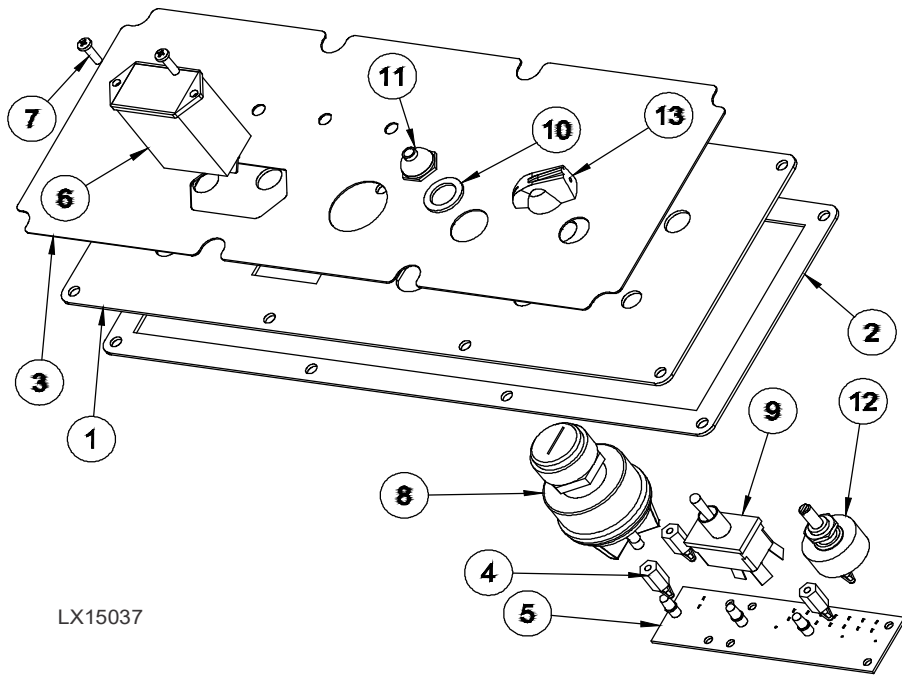

REF	DESCRIPTION (◆ Indicates Parts Available In Assemblies Only)	PART #	QTY.
	Panel Assembly,Front (LX150 G25/LX250 G38/E15)	073673	1
1	Panel Weldment, Face	015302	1
2	Gasket, Face Panel	015270	1
3	Decal, Gas/Elec Sawmill Control Panel	015271	1
4	Standoff, PCB 1/2 #6 Female Threading	023147	4
5	PCB Assembly, LED Diesel Sawmill 1997	015416	1
6	Meter, Hour Rectangle Mount	015401	1
7	Screw, #6-32X1/2 Phil Pan HD T23, ZN	F05015-28	2
8	Switch, Key	P04350	1
9	Switch, Toggle 21A DPDT Rev Mom Spade	024200	1
10	Washer, 1/2x3/4x1/16 Nylon	P05251-1	1
11	Boot, Toggle Switch	P02575	1
12	Pot Assembly, Feed Rate Control Sawmill	024450-1	1
13	Knob, Speed Control	P06257	1
	LX250G38 Harnesses		
	Harness Assy, LX250G38 Upper	073578	1
	Harness Assy, LX250 Feed	073677	1
	Harness Assy, LX250 Up/Down	073678	1
	LX150G25 Harnesses		
	Harness Assy, LX150G25 Upper	073587	
	Harness Assy, LX150 Feed	073562	
	Harness Assy, LX150 Up/Down	073563	

5.6 Fuse Box

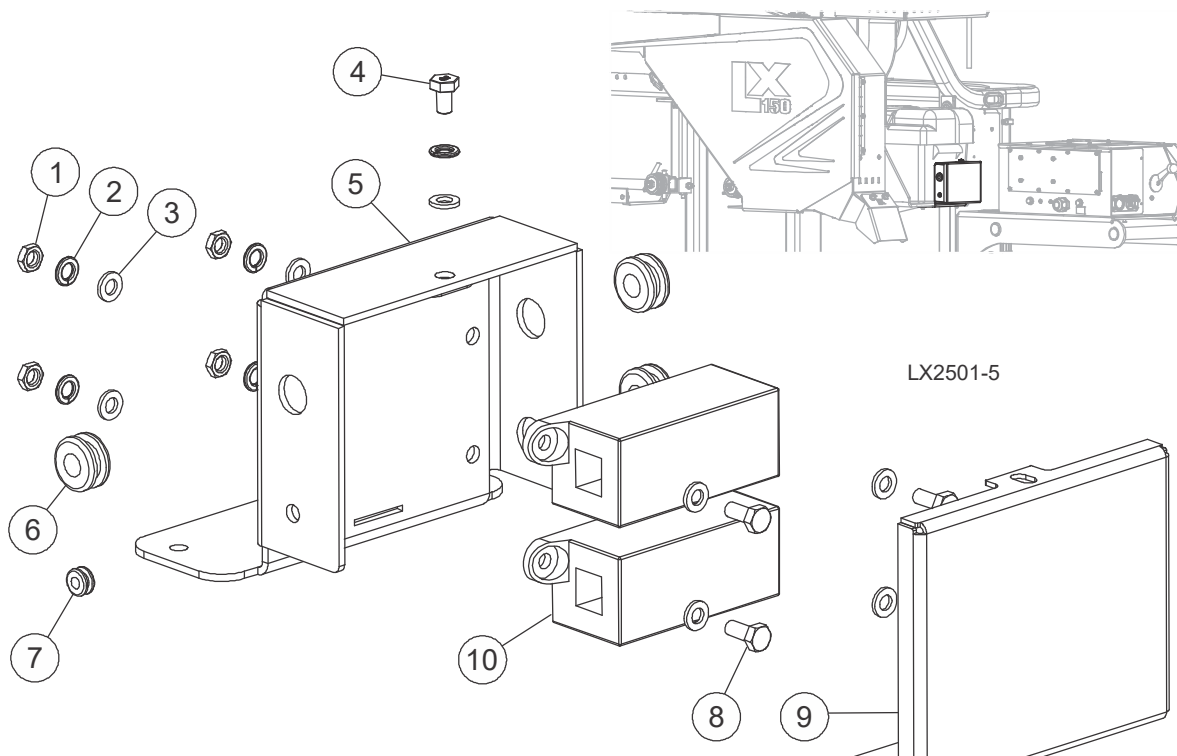

REF	DESCRIPTION (♦ Indicates Parts Available in Assemblies Only)	PART #	QTY.
	Assy, LX Fuse Block	128208	
1	Nut, M6 x 1 Hex Jam	F05010-226	4
2	Washer, M6 Split Lock	F05026-2	5
3	Washer, M6 Flat Class 4	F05026-1	9
4	Bolt, M6-1x10mm HH FT 8.8 Zinc	F05020-59	1
5	Weldment, LX Fuse Block	128207	1
6	Grommet, Rubber 3/8 Dia	025248	3
7	Grommet, 9/32Holex3/16IDx7/16OD	042825	1
8	Bolt, M6-1 x 14 Class 8 HH	F05020-7	4
9	Cover, LX Fuse Block	128206	1
10	Fuseholder, Mega Fuse ¹	052371	2
	Fuse, 150A Mega ²	052370-150	1
	Fuse, 60A Mega	052370-060	1

¹ Quantity of 1 used on electric mills.

² Not used on the electric mills.

3.7 Battery Box Assembly

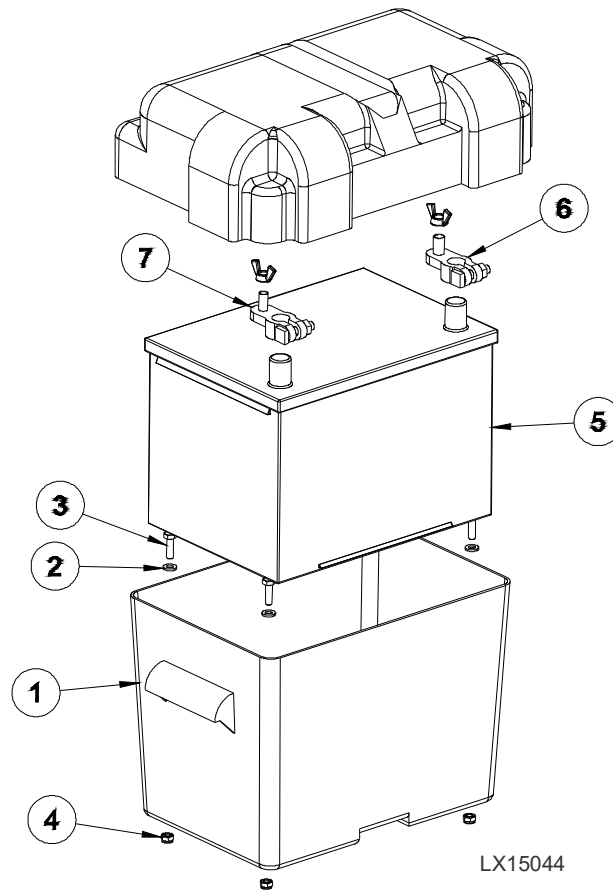

REF	DESCRIPTION (◆ Indicates Parts Available In Assemblies Only)	PART #	QTY.	
	Assembly, LX150/LX250 Battery Box	110400	1	
1	Box, Battery, Modified	016413	1	
2	Washer, M6 Flat Class 4	F05026-1	4	
3	Bolt, M6-1 x 20 Class 8 HH	F05020-6	4	
4	Nut, M6-1.0 Nylon Lock	F05010-200	4	
5	Battery, 580 CCA Deka	079462	1	
6	Clamp, Pos. Battery	033358	1	
7	Clamp, Neg. Battery	033359	1	
	For mills built prior to 12/16/2019:			
	Fuse, 60A ZCase ¹	073683	1	
	Fuse, 150A ZCase ¹	073684	1	
	Fuse Holder, Single ZCase ¹	073685	2	

¹ Changed and removed fuses from inside the battery box to the fuse block assembly next to the battery box as of 12/16/2019.

SECTION 6 UP/DOWN SYSTEM

6.1 Mast Pad & Hardware

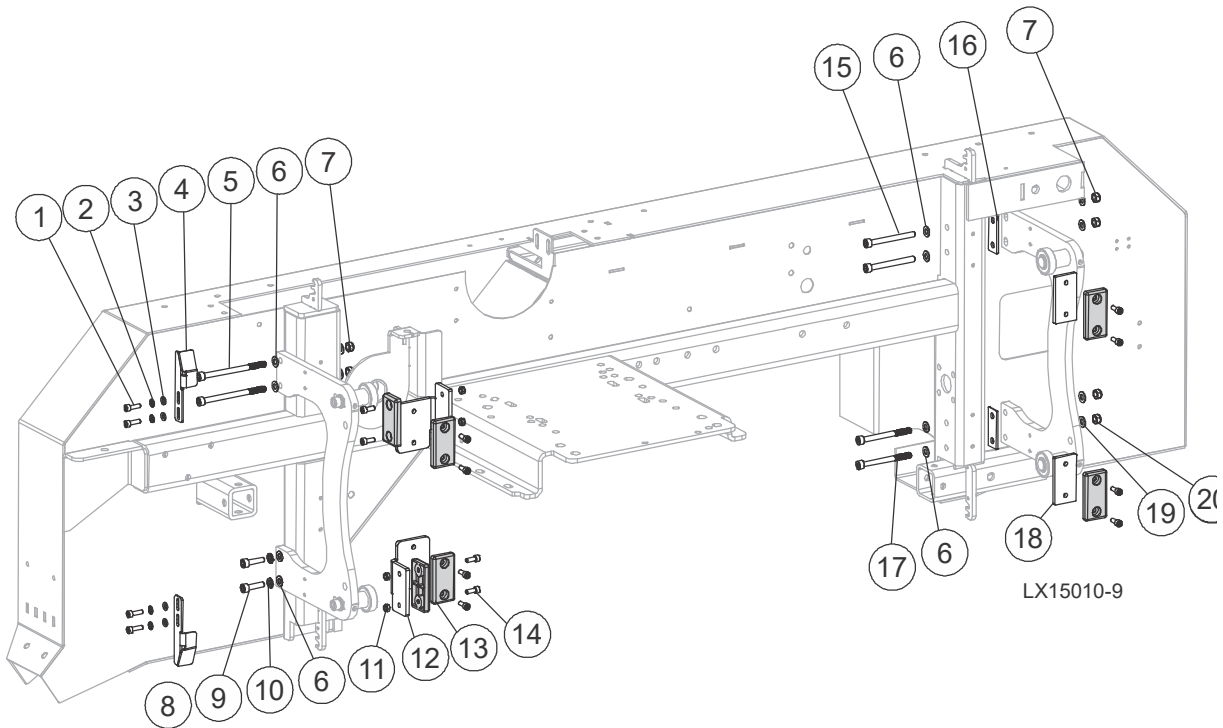

REF	DESCRIPTION (◆ Indicates Parts Available In Assemblies Only)	PART #	QTY.	
1	SCREW, M6-1 X 20 SHC	F05020-15	4	
2	WASHER, M6 SPLIT LOCK	F05026-2	4	
3	WASHER, M6 FLAT CLASS 4	F05026-1	4	
4	BRACKET, UPPER LIMIT SWITCH	110800	1	
5	SCREW, M8-1.25X110MM SHCS	F05021-39	3	
6	WASHER, M8 FLAT	F05026-4	10	
7	NUT, M8-1.25 HEX NYLOCK	F05010-132	4	
8	BRACKET, LOWER LIMIT SWITCH	011323	1	
9	SCREW, M6-1 X 20 SHC	F05020-15	2	
10	WASHER, 8MM SPLIT LOCK, ZN	F05011-45	2	
11	NUT, M6-1.0 NYLON LOCK	F05010-200	4	
12	BRACKET, SLIDE PAD MOUNT	110806	2	
13	PAD, CATAPILLAR TRACK	P13576	6	
14	BOLT, M6-1.0X16MM SHCS	F05004-206	12	
15	SCREW, M8-1.25 X 80 SHC FT	F05021-27	2	
16	SHIM PLATE, MAST ROLLERS	110599	2	
17	SCREW, M8-1.25X85MM SHCS	F05021-37	2	
18	SHIM, SLIDE PAD, 1/4	110807	2	
19	WASHER, 8.4 FLAT, ZINC	F81054-1	2	
20	NUT, M8-8-B, HEX, NYLON LOCK ZINC	F81032-2	2	

6.2 Blade Height Scales & Mast Angles

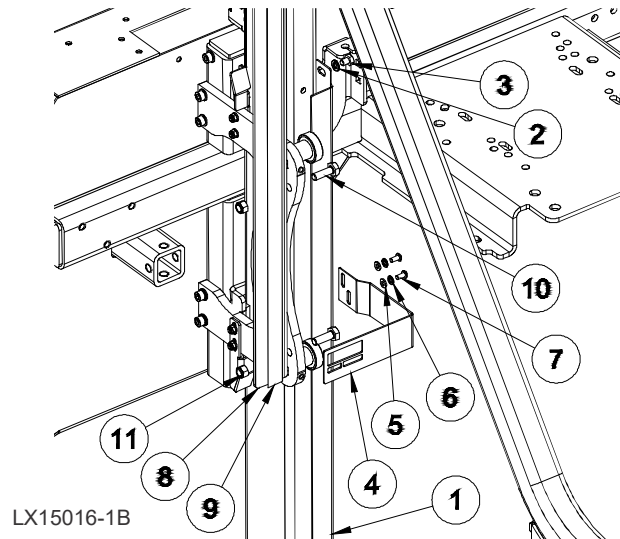

REF	DESCRIPTION (◆ Indicates Parts Available In Assemblies Only)	PART #	QTY.
1	ANGLE, MAST TUBE STAINLESS	033827	2
2	WASHER, M8 SPLIT LOCK	F05011-45	1
3	BOLT, M8-1.25X10MM HHC	F05021-51	6
4	PLATE, SIGHT GAUGE	110896 ¹	1
5	WASHER, M6 FLAT CLASS 4	F05026-1	2
6	WASHER, M6 SPLIT LOCK	F05026-2	2
7	SCREW, M6-1.0 X 12MM BHCS BLACK OXIDE	F05004-275	2
8	SUPPORT, DEPTH GAUGE	108023	1
9	DECAL, MOVABLE INCH SCALE	S11773	1
10	BOLT, M10-1.5X30 CLASS 8 HH	F05022-3	2
11	NUT, M10-1.50 HEX NYL LOCK	F05004-270	2

¹ Sight Guide Plate changed from 108025 to 110896 as of revision A2.00 (5/2019).

6.3 Head Mounting Assembly

Rev A2.00+

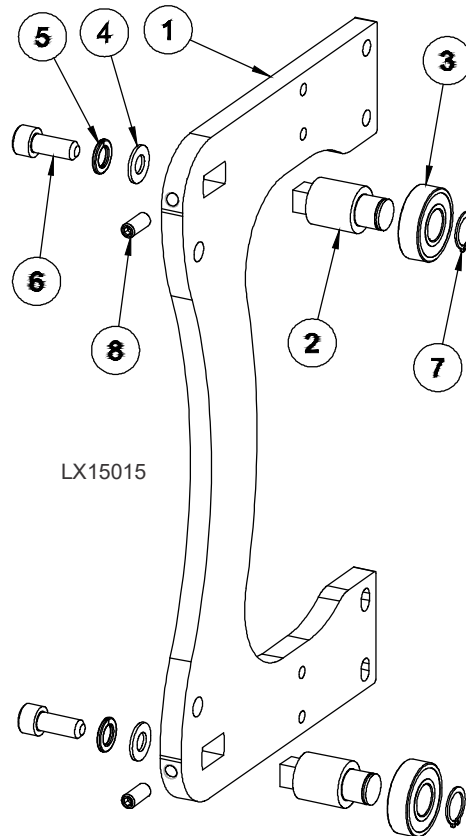

REF	DESCRIPTION (◆ Indicates Parts Available In Assemblies Only)	PART #	QTY.	
	ASSEMBLY, LX150 HEAD MOUNTING	110808	1	
1	Guide, LX150 Mast	110799	1	
2	Shaft, Head Hold Down	011137	2	
3	Bearing, 6203-2NSL 17mm SRI-2 ABEC-1	P06030-2	2	
4	Washer, M10 Flat	F05011-134	2	
5	Washer, 10MM Split Lock	F05011-88	2	
6	Bolt, M10-1.5 x 25 SHC	F05022-12	2	
7	Ring, 17mm OR	F04254-16	2	
8	Screw, M8-1.25 x20 SHFP Set	F05021-7	2	

6.4 Head Mounting Assembly

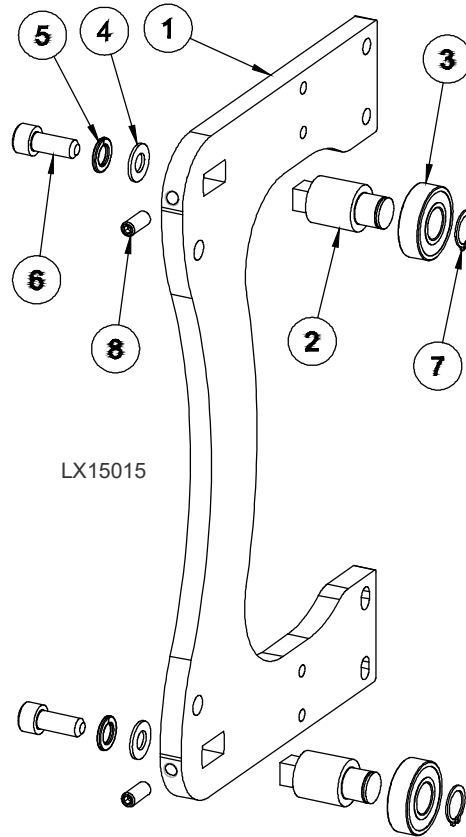

REF	DESCRIPTION (◆ Indicates Parts Available In Assemblies Only)	PART #	QTY.
	ASSEMBLY, LX150 HEAD MOUNTING	011114	1
1	Guide, LX150 Mast	011009	1
2	Shaft, Head Hold Down	011137	2
3	Bearing, 6203-2NSL 17mm SRI-2 ABEC-1	P06030-2	2
4	Washer, M10 Flat	F05011-134	2
5	Washer, 10MM Split Lock	F05011-88	2
6	Bolt, M10-1.5 x 25 SHC	F05022-12	2
7	Ring, 17mm OR	F04254-16	2
8	Screw, M8-1.25 x20 SHFP Set	F05021-7	2

6.4 Up/Down Assembly

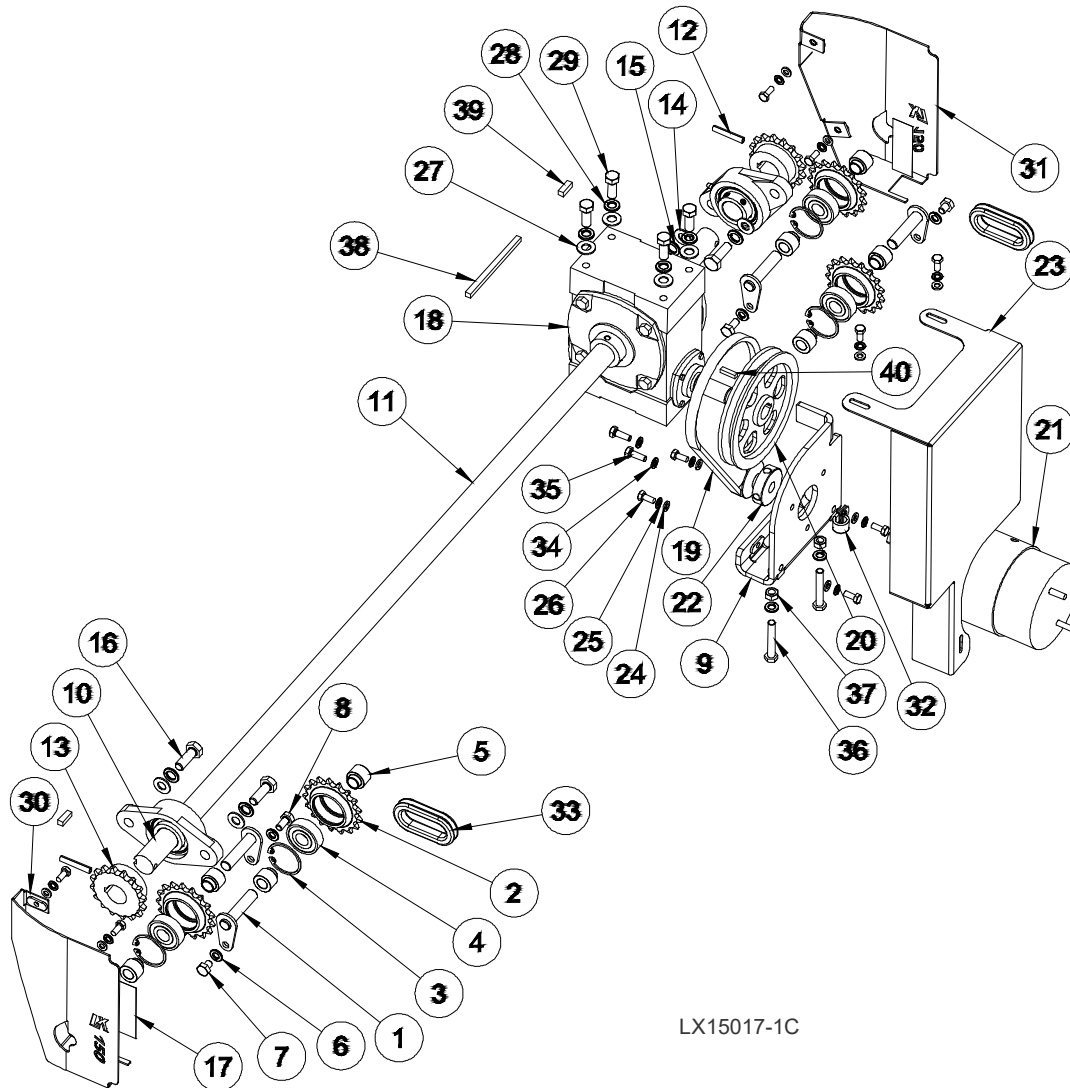

REF	DESCRIPTION (◆ Indicates Parts Available In Assemblies Only)	PART #	QTY.
1	WELDMENT, 1/2X2-1/8 IDLER PIN	011213	4
	SPROCKET ASSEMBLY, #40/#41 CHAIN 17T	016366	4
2	Sprocket, #40/41 Chain 17 Tooth	016365	1
3	Ring, 1.575 Id N5100-156 Snap	F04254-4	1
4	Bearing, Japanese 6203-2RS 5/8 C3/ALV3	N/A	1
5	BUSHING, IDLER SPACING	011176	8
6	WASHER, 8MM SPLIT LOCK, ZN	F05011-45	5
7	BOLT, M8-1.25X20MM HEX HEADC	F05021-51	2
8	BOLT, M8-1.25X16 HEX HEAD ZINC	F05004-47	2
9	WELDMENT, DC UP/DN MOTOR ADJUST	011300	1
10	BEARING, 1 FLANGED, VF2S 216	038124	2
11	SHAFT, LX150 UP/DN	011211	1
12	PIN, 1/4 X 1-1/2 ROLL	F05012-125	2
13	SPROCKET, 40B16X1	007311	2

14	WASHER, M10 FLAT	F05011-134	4	
15	WASHER, 10MM SPLIT LOCK	F05011-88	4	
16	BOLT, M10-1.5X30 HEX HEAD CLASS 8	F05022-3	4	
17	DECAL, 3X1 ORANGE VINYL	011284	2	
18	GEARBOX, 60:1 THRU SHAFT	011317	1	
19	BELT, 4L245	038459	1	
20	SHEAVE, 5.45 OD 3/4 BORE 4L	066781	1	
21	MOTOR, 1/2HP 12VDC, CURRENT APPLICATIONS	006747	1	
22	SHEAVE, 1 3/4 FEED MOTOR	S09579	1	
23	GUARD, LX150 UP/DN	011392	1	
24	WASHER, M6 FLAT CLASS 4	F05026-1	10	
25	WASHER, M6 SPLIT LOCK	F05026-2	10	
26	BOLT, M6-1 X 14 CLASS 8 HEX HEAD	F05020-7	10	
27	WASHER, 3/8 FLAT SAE	F05011-3	4	
28	WASHER, 3/8 SPLIT LOCK	F05011-4	4	
29	BOLT, 3/8-16X1 GR5 HEX HEAD	F05007-87	4	
30	WELDMENT, LX150 LEFT SPROCKET GUARD	011135	1	
31	WELDMENT, LX150 RIGHT SPROCKET GUARD	011129	1	
32	CLAMP, 1/2 IDX9/32 MOUNTING HOLE COATED	011295	1	
33	GROMMET, 1-3/4" ID X 2" HOLE RUBBER	011269	2	
34	WASHER, 1/4 SPLIT LOCK	F05011-14	3	
35	BOLT, 1/4-20X3/4 HEX HEAD GR5 ¹	F05005-123	3	
36	BOLT, M8X50 8.8 HEX HEAD FT ZINC	F81002-19	2	
37	NUT, M8-1.25 FREE ZINC	F05010-162	2	
38	KEY, 1/4X4 1/4	S22440	1	
39	KEY, 1/4 SQX3/4 LONG	S03167	2	
40	KEY, 3/16 SQX3/4 LONG	S03060	1	

¹ Second F05005-123 and F81002-19 bolts added after 11/21/2019.

SECTION 7 FEED SYSTEM & TRACK ROLLERS

7.1 Track Rollers and Wipers (Drive Side)

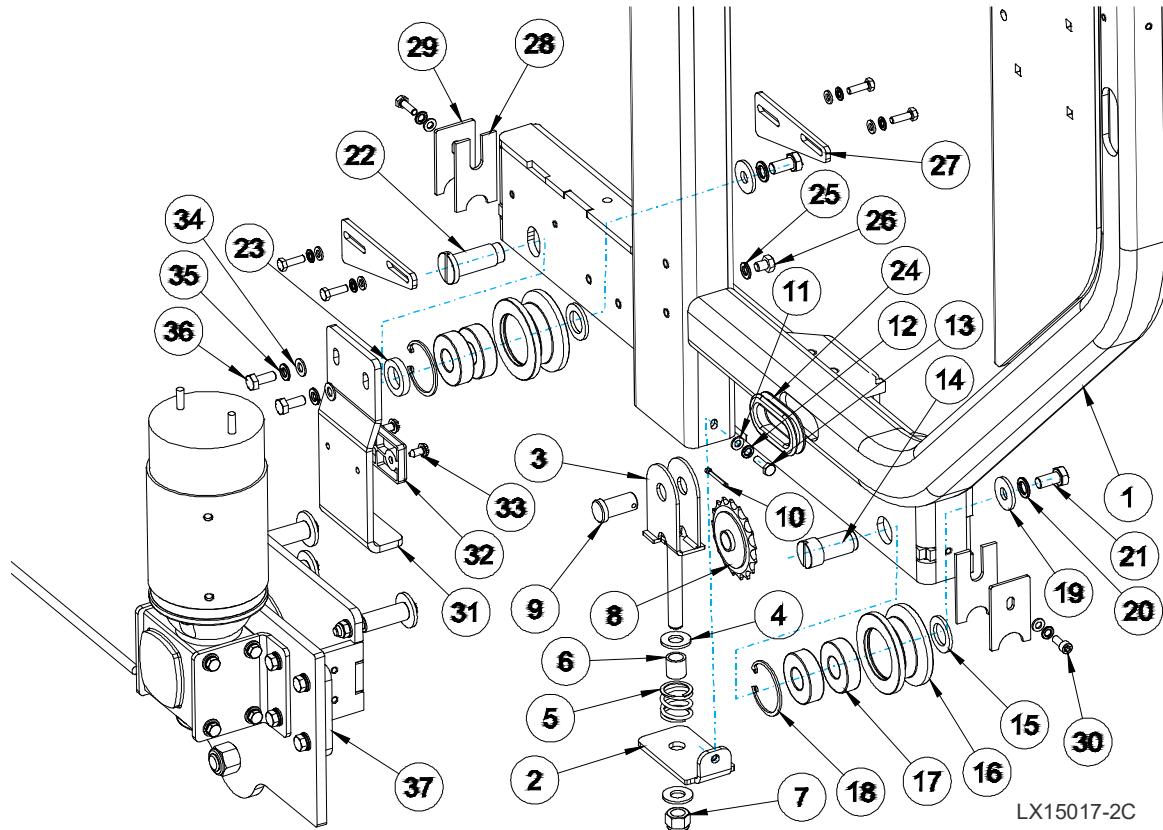

LX15017-2C

REF	DESCRIPTION (◆ Indicates Parts Available In Assemblies Only)	PART #	QTY.
1	UPRIGHT WELDMENT, LX150	011025	1
2	WELDMENT, TENSION SPROCKET MOUNTING ASSEMBLY, LX150 UP/DN CHAIN TENSION	011372	1
3	Weldment, LX150 Up/Dn Chain Tension	011369	1
4	Washer, 1/2 SAE Flat	F05011-2	2
5	Spring, 1ODx1Longx.125Wire Comp	016516	1
6	Spacer, Up/Dn Chain Tensioner	016515	1
7	Nut, 1/2-13 Nyl Hex Lock	F05010-8	1
8	Sprocket, #40 Idler 17T 5/8ID	P04333	1
9	Pin, 5/8x1 Usable Lg. Clevis	F05012-159	1
10	Pin, 1/8x1 Cotter	F05012-1	1
11	WASHER, M6 FLAT CLASS 4	F05026-1	7
12	WASHER, M6 SPLIT LOCK	F05026-2	7
13	BOLT, M6-1X20 HEX HEAD CLASS 8	F05020-6	6
14	SHAFT, LX150 ROLLER	515018	1
15	WASHER, LX150 THIN ROLLER	011351	2
16	ROLLER ASSEMBLY, LX150	515015_US	2
16	Roller, LX150	514889_US	1

17	Bearing, 6204 2RRS-CX Rolling	088447	2	
18	Ring, Retaining W 47, Pn-81/m-85111	089653	1	
19	SPACER, LX150 HEIGHT ADJUST	088787	2	
20	WASHER, 10MM SPLIT LOCK	F05011-88	2	
21	BOLT, M10-1.50X20MM HEX HEAD FT 8.8	F05004-207	2	
22	SHAFT, LX100/150 ADJUSTMENT	515101	1	
23	WASHER, LX150 THICK ROLLER	011352	1	
24	GROMMET, 1-3/4" ID X 2" HOLE RUBBER	011269	1	
25	WASHER, 8MM SPLIT LOCK, ZN	F05011-45	1	
26	BOLT, M8-1.25X20MM HEX HEADC	F05021-51	1	
27	PLATE, LX150 HEIGHT ADJUST	516508-1	2	
28	WIPER	517609	2	
29	PLATE, LX150 RAIL WIPER	517610-1	2	
30	BOLT, M6-1.0X16MM SHCS	F05020-6	1	
	ASSEMBLY, LX150 MAST SAFETY	011120	1	
31	Plate, LX150 Mast Safety	011119	1	
32	Pad, Catapillar Track	P13576	1	
33	Bolt, 1/4-20x1/2 SI Hex Head	F05015-1	2	
34	Washer, M8 Flat	F05026-4	2	
35	Washer, 8mm Split Lock, Zn	F05011-45	2	
36	Bolt, M8-1.25x20 Class 8 Hex Head	F05021-2	2	
37	ASSEMBLY, LX150 ROPE POWER FEED (See Section 7.3 for parts)	011381	1	

7.2 Track Roller And Wipers (Idle Side)

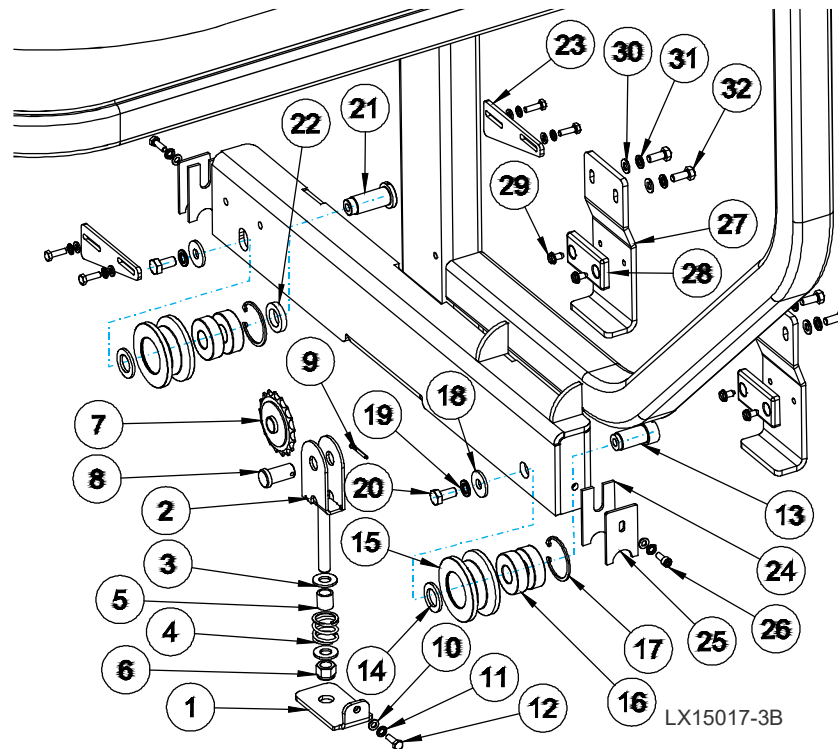

REF	DESCRIPTION (◆ Indicates Parts Available In Assemblies Only)	PART #	QTY.
1	WELDMENT, TENSION SPROCKET MOUNTING	011372	1
	ASSEMBLY, #40 CHAIN TENSION	011370	1
2	Weldment, #40 Chain Tension	011369	1
3	Washer, 1/2 SAE Flat	F05011-2	2
4	Spring, 1ODx1Longx.125Wire Comp	016516	1
5	Spacer, Up/Dn Chain Tensioner	016515	1
6	Nut, 1/2-13 Nyl Hex Lock	F05010-8	1
7	Sprocket, #40 Idler 17T 5/8ID	P04333	1
8	Pin, 5/8x1 Usable Lg. Clevis	F05012-159	1
9	Pin, 1/8x1 Cotter	F05012-1	1
10	WASHER, M6 FLAT CLASS 4	F05026-1	7
11	WASHER, M6 SPLIT LOCK	F05026-2	7
12	BOLT, M6-1X20 HEX HEAD CLASS 8	F05020-6	6
13	SHAFT, LX150 ROLLER	515018	1
14	WASHER, LX150 THIN ROLLER	011351	2
	ROLLER ASSEMBLY, LX150	515015_US	2
15	Roller, LX150	514889_US	1
16	Bearing, 6204 2RRS-CX Rolling	088447	2
17	Ring, Retaining W 47, Pn-81/m-85111	089653	1
18	SPACER, LX150 HEIGHT ADJUST	088787	2
19	WASHER, 10MM SPLIT LOCK	F05011-88	2
20	BOLT, M10-1.50X20MM HEX HEAD FT 8.8	F05004-207	2
21	SHAFT, LX100/150 ADJUSTMENT	515101	1

22	WASHER, LX150 THICK ROLLER	011352	1	
23	PLATE, LX150 HEIGHT ADJUST	516508-1	2	
24	WIPER	517609	2	
25	PLATE, RAIL WIPER	517610-1	2	
26	BOLT, M6-1.0X16MM SHCS	F05020-6	1	
	ASSEMBLY, MAST SAFTEY	011120	2	
27	Plate, Mast Saftey	011119	1	
28	Pad, Catapillar Track	P13576	1	
29	Bolt, 1/4-20x1/2 SI Hex Head	F05015-1	2	
30	WASHER, M8 FLAT	F05026-4	2	
31	WASHER, M8 SPLIT LOCK	F05011-45	2	
32	BOLT, M8-1.25X20 CLASS 8 HEX HEAD	F05021-2	2	

7.3 Power Feed Assembly

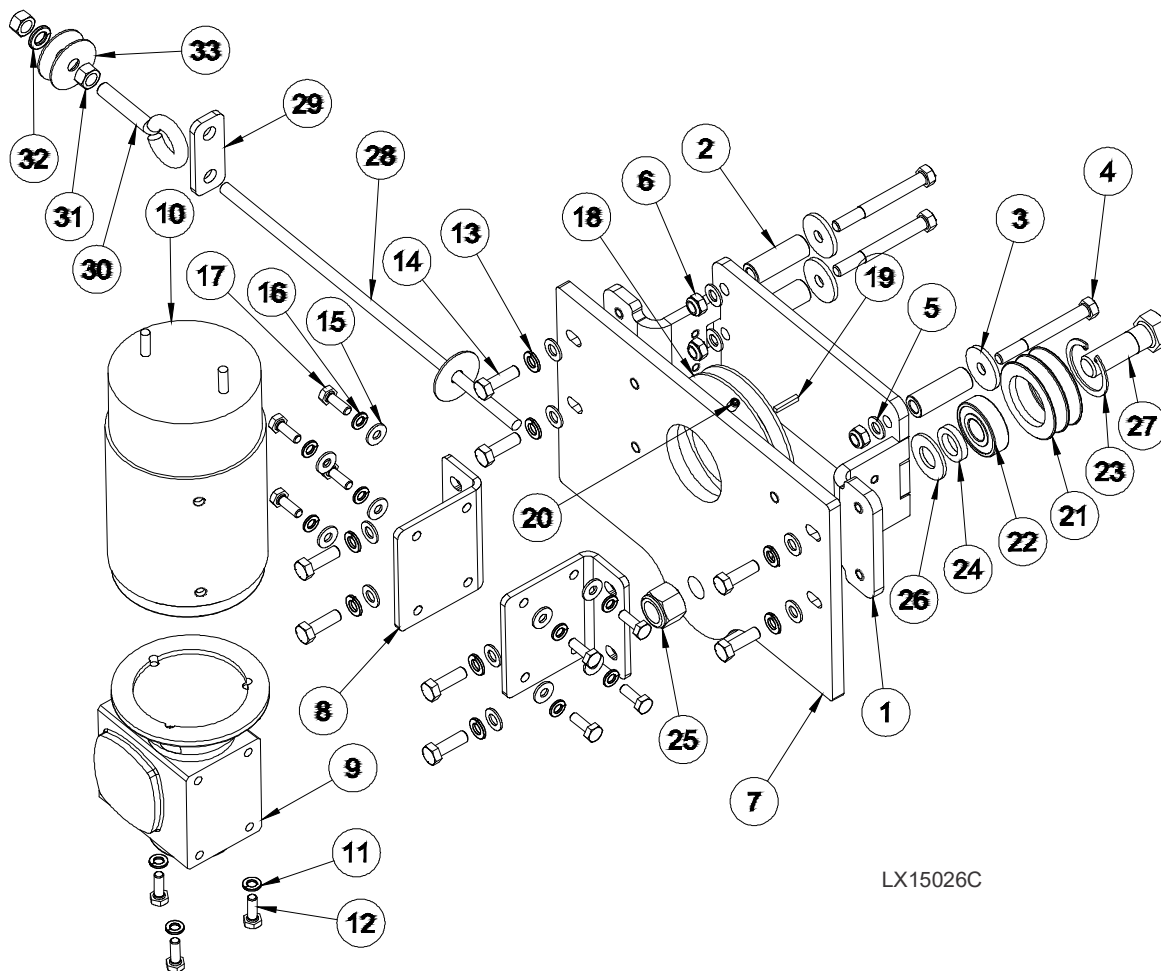

LX15026C

REF	DESCRIPTION (◆ Indicates Parts Available In Assemblies Only)	PART #	QTY.
	ASSEMBLY, LX150 ROPE POWER FEED	011381	1
1	Weldment, Rope Power Feed Mounting	517886-1	1
2	Spacer, Power Feed Mounting	517914-1	3
3	Washer, 5/16 x 1-1/4 x 1/8 Zn	F05011-105	3
4	Bolt, M8-1.25x75mm Hex Head Class8.8	F05021-34	3
5	Washer, M8 Flat	F05026-4	11
6	Nut, M8-1.25 Hex Nylock	F05010-132	3
7	Plate, LX150 Power Feed Mnt	011378	1
8	Plate, LX150 Gearbox Mounting	011379	2
	Assembly, LX150 PF Motor/Gearbox	011151	1
9	Gearbox, 10:1 x 1/2hp	011155	1
10	Motor, 1/2hp 12VDC, Current Applications	006747	1
11	Washer, 1/4 Split Lock	F05011-14	3
12	Bolt, 1/4-20x3/4 Hex Head Gr5	F05005-123	3
13	Washer, 8mm Split Lock, Zn	F05011-45	8
14	Bolt, M8x1.25x25 Hex Head FT	F05004-40	8
15	Washer, 1/4 SAE Flat	F05011-11	8

16	Washer, 1/4 Split Lock	F05011-14	8	
17	Bolt, 1/4-20x3/4 FT Hex HeadC	F05005-1	8	
18	Pulley, LX150 Rope Feed	011353	1	
19	Key, 1/8 x 3/4 Machine	060089	1	
20	Screw, 1/4-20 X 3/8 Half Dog BO Set	F05005-108	2	
	Roller Assembly, Lower Feed	046979	1	
21	Roller, 2 1/4 Double Groove	046838	1	
22	Bearing, 5/8x1.7548x.4724	P06030-1	1	
23	Ring, 1.575 Internal Beveled Retaining	F04254-8	1	
24	Tube, 41/64x1x3/16	S12480	1	
25	Nut, 5/8-11 Nyl Lock	F05010-34	1	
26	Washer, 5/8 SAE Flat	F05011-5	1	
27	Bolt, 5/8-11x2 Hex Hd Gr2, Zn	F05009-2	1	
28	Rope, 5/16 Dia Solid Braided Poly 34Ft	018035	1	
29	Plate, Rope Lock	049339	1	
30	Bolt, 3/8-16 X 2 Eye 5/8 Id	F05007-30	1	
31	Nut, 3/8-16 Hex	F05010-1	2	
32	Washer, 3/8 Split Lock	F05011-4	1	
33	Washer, 3/8 Fender	F05011-44	3	

7.4 Travel Lock Assembly

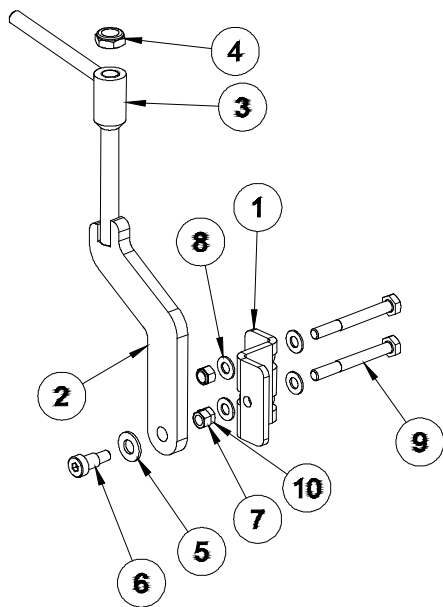

LX15036B

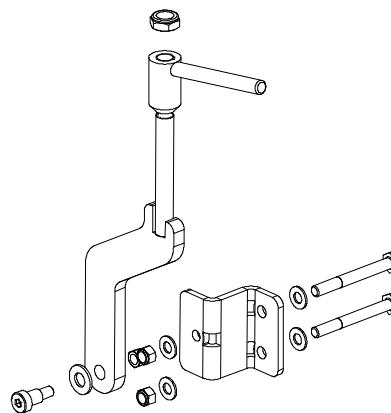

REF	DESCRIPTION (◆ Indicates Parts Available In Assemblies Only)	PART #	QTY.
	LOCK ASSEMBLY, TRAVEL	110741	1
1	Bracket, Travel Lock Mount	110778	2
2	Lock Weldment, Travel	079600	2
3	Nut Weldment, Travel Lock	079747	2
4	Nut, 5/8-18 Nyl Jam	F05010-101	2
5	Washer, 1/2 SAE Flat	F05011-2	2
6	Bolt, 1/2x5/8 Shoulder 3/8-16 Thrd Unplated	F05008-115	2
7	Nut, 3/8-16 Swaged	F05010-25	2
8	Washer, M10 Flat	F05011-134	8
9	Bolt, M10-1.5x90 Hex Head Class 8	F05022-22	4
10	Nut, M10-1.50 Hex Nyl Lock	F05004-270	4

SECTION 8 BED FRAME ASSEMBLY

8.1 Bed Frame Assembly

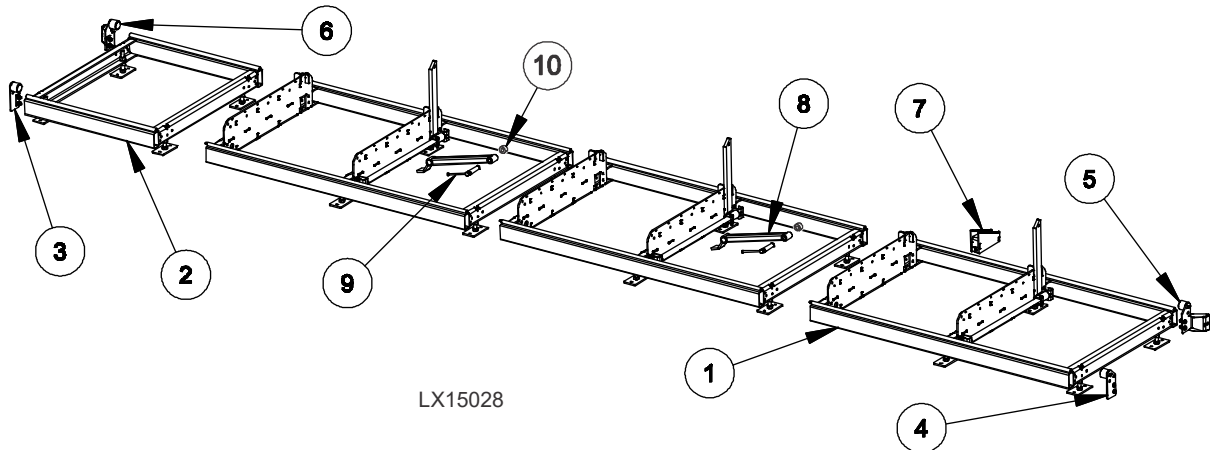

REF	DESCRIPTION (◆ Indicates Parts Available In Assemblies Only)	PART #	QTY.
	BED ASSEMBLY, LX150	516522-S3	1
1	Bed, Section (See Section 8.2)	516521	1
2	Bed, Section Front (See Section 8.3)	516524	1
3	Stop Assembly, Front Left Complete (See Section 8.4)	515062	1
4	Stop Assembly, Rear Left Complete (See Section 8.5)	515063	1
5	Stop Assembly, Rear Right Complete (See Section 8.6)	517897	1
6	Stop Assembly, Front Right Complete (See Section 8.7)	517896	1
7	Wedge, LX100	515413-1	1
8	Arm, LX150 Clamp	524191-1	2
9	Bolt, Clamp Complete	507563	2
10	Block, Clamp Point	075295	2

8.2 Bed Section Assembly

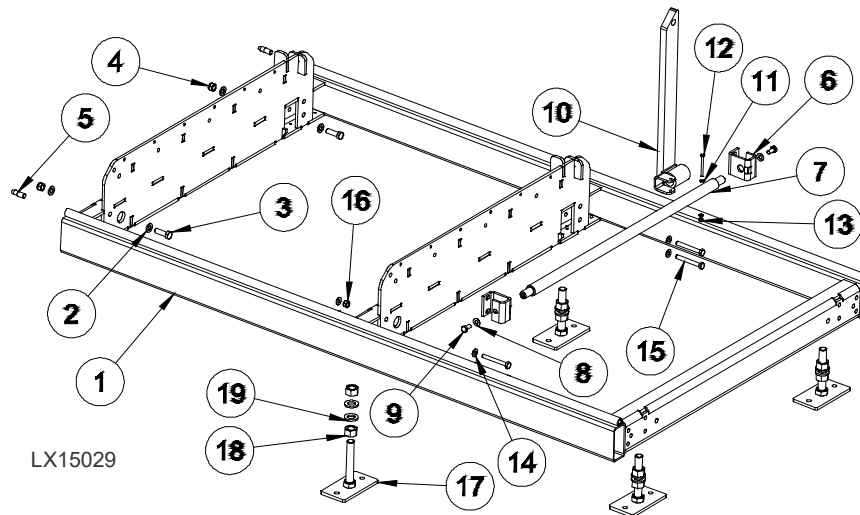

REF	DESCRIPTION (◆ Indicates Parts Available In Assemblies Only)	PART #	QTY.
	BED SECTION ASSEMBLY, LX150	516521	1
1	Weldment, Bed Section	516264-1	1
2	Washer, M12 Flat Zinc	F81056-1	4
3	Bolt, M12x40-8.8-Fe/Zn5 PN-M/82105	F81004-4	2
4	Nut, M12-8 Fe/Zn5 PN-M/82175	F81034-2	2
5	Stud, Special	090675	2
	Support Assembly, LX150 Side	516519	1
6	Bracket, Clamp Mount	500338-1	2
7	Rod, Clamp	516520-1	1
8	Washer, Flat 10,5 Fe/Zn5 PN-78/M-82005	F81055-1	2
9	Bolt, M10x20-5.8-Fe/Zn5 PN-M/82105	F81003-1	2
	Support, Side Complete	524190	1
10	Weldment, Side Support	524189-1	1
11	Washer, M6 Flat Zinc	F81053-	2
12	Bolt, M6x60-8.8-Fe/Zn5 PN-85/M-82105	F81001-9	1
13	Nut, M6-8-B-Fe/Zn5 PN-M/82175	F81031-2	1
14	Washer, Flat 10,5 Fe/Zn5 PN-78/M-82005	F81055-1	8
15	Bolt, M10x80 -8.8- Fe/Zn5 PN-M/82101	F81003-50	4
16	Nut, M10-8-B -Fe/Zn PN-M82175	F81033-1	4
	Leg Assembly, LT15 Complete	514997	4
17	Leg, LT15	514996-1	1
18	Nut, M20-8-Fe/Zn5 PN-86/M-82144	F81037-1	2
19	Washer, 21 Fe/Zn5 PN-M/82005	F81059-2	2

8.3 Bed Section Assembly, Front

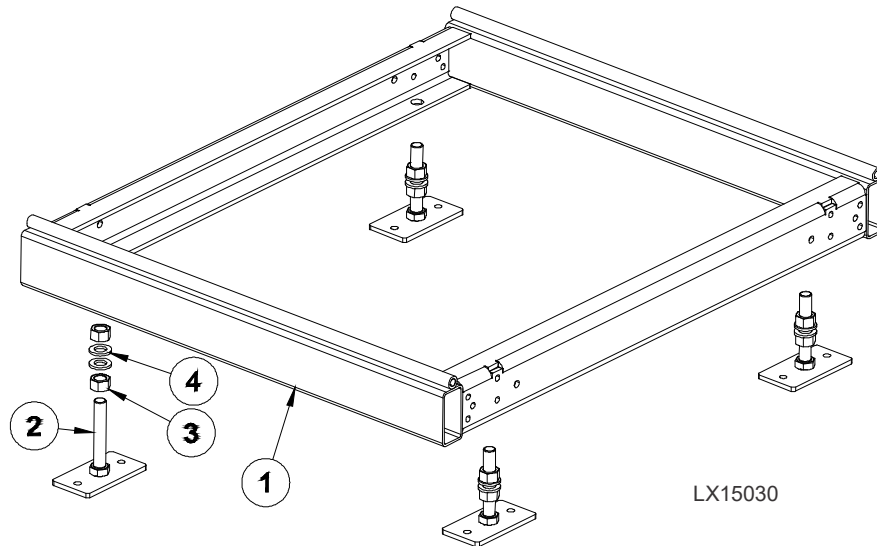

REF	DESCRIPTION (◆ Indicates Parts Available In Assemblies Only)	PART #	QTY.	
	BED SECTION ASSEMBLY, LX150 FRONT	516524	1	
1	Weldment, Bed Section	516254-1	1	
	Leg Assembly, LT15 Complete	514997	4	
2	Leg, LT15	514996-1	1	
3	Nut, M20-8-Fe/Zn5 PN-86/M-82144	F81037-1	2	
4	Washer, 21 Fe/Zn5 PN-M/82005	F81059-2	2	

8.4 Bed Stop Assembly, Front Left

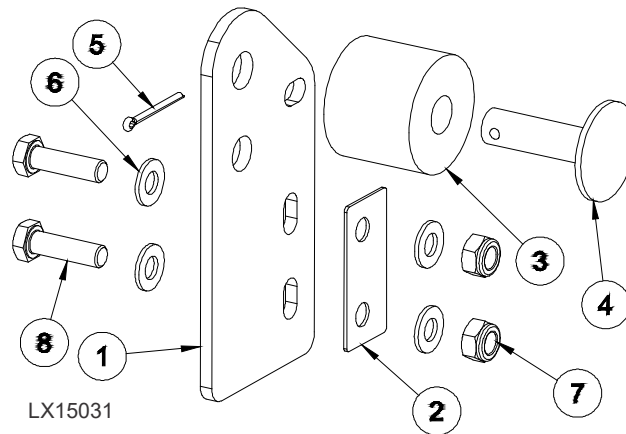

REF	DESCRIPTION (◆ Indicates Parts Available In Assemblies Only)	PART #	QTY.	
	BED STOP ASSEMBLY, FRONT LEFT	515062	1	
1	Plate, Bed Stop	516075-1	1	
2	Plate, Bed Stop Shim	515061-1	1	
3	Bushing, Bed Stop	P12165	1	
4	Bolt, Bed Stop	086182-1	1	
5	Pin, Roll S-Zn 4x25 PN-M/82001	F81043-2	1	
6	Washer, Flat 10,5 Fe/Zn5 PN-78/M-82005	F81055-1	4	
7	Nut, M10-8-B -Fe/Zn PN-M82175	F81033-1	2	
8	Bolt, M10x35-8.8 Fe/Zn5 PN-M/82105	F81003-17	2	

8.5 Bed Stop Assembly, Rear Left

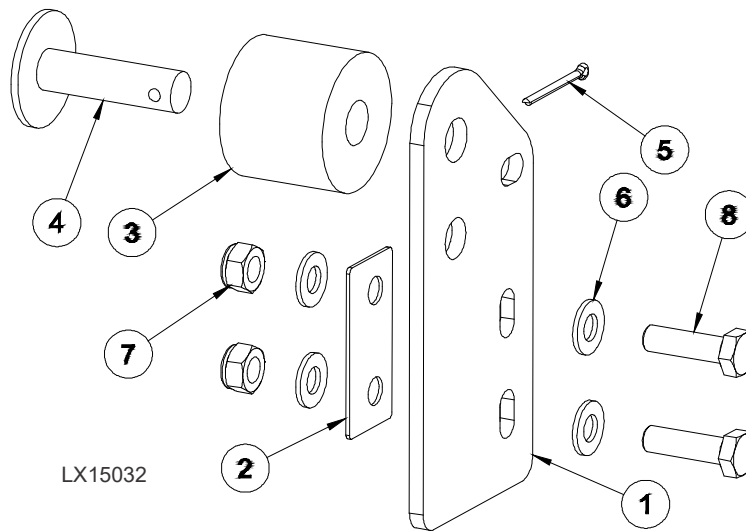

REF	DESCRIPTION (◆ Indicates Parts Available In Assemblies Only)	PART #	QTY.	
	BED STOP ASSEMBLY, REAR LEFT	515063	1	
1	Plate, Bed Stop	516075-1	1	
2	Plate, Bed Stop Shim	515061-1	1	
3	Bushing, Bed Stop	P12165	1	
4	Bolt, Bed Stop	086182-1	1	
5	Pin, Roll S-Zn 4x25 PN-M/82001	F81043-2	1	
6	Washer, Flat 10,5 Fe/Zn5 PN-78/M-82005	F81055-1	4	
7	Nut, M10-8-B -Fe/Zn PN-M82175	F81033-1	2	
8	Bolt, M10x35-8.8 Fe/Zn5 PN-M/82105	F81003-17	2	

8.6 Bed Stop Assembly, Front Right

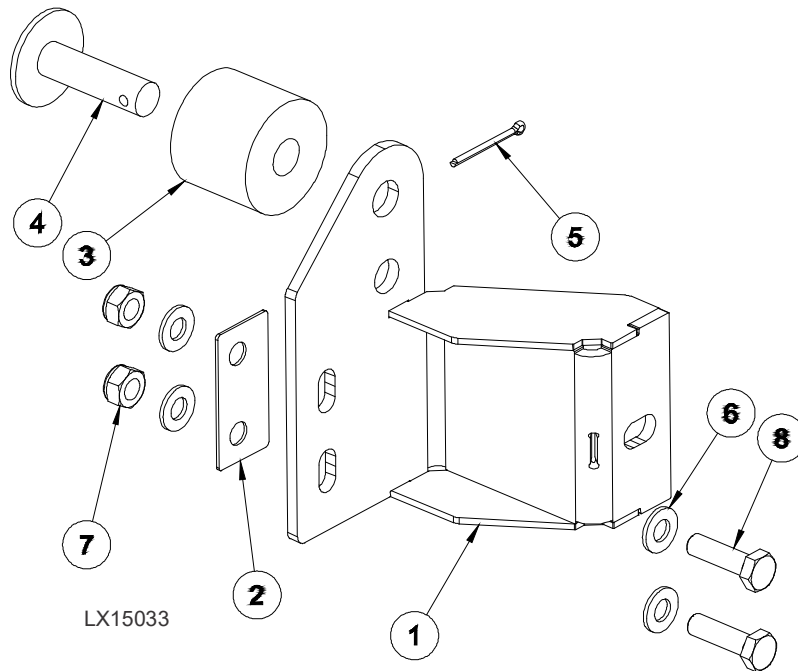

REF	DESCRIPTION (◆ Indicates Parts Available In Assemblies Only)	PART #	QTY.
	BED STOP ASSEMBLY, REAR RIGHT	517897	1
1	Plate, Bed Stop	517902-1	1
2	Plate, Bed Stop Shim	515061-1	1
3	Bushing, Bed Stop	P12165	1
4	Bolt, Bed Stop	086182-1	1
5	Pin, Roll S-Zn 4x25 PN-M/82001	F81043-2	1
6	Washer, Flat 10,5 Fe/Zn5 PN-78/M-82005	F81055-1	4
7	Nut, M10-8-B -Fe/Zn PN-M82175	F81033-1	2
8	Bolt, M10x35-8.8 Fe/Zn5 PN-M/82105	F81003-17	2

8.7 Bed Stop Assembly, Front Right

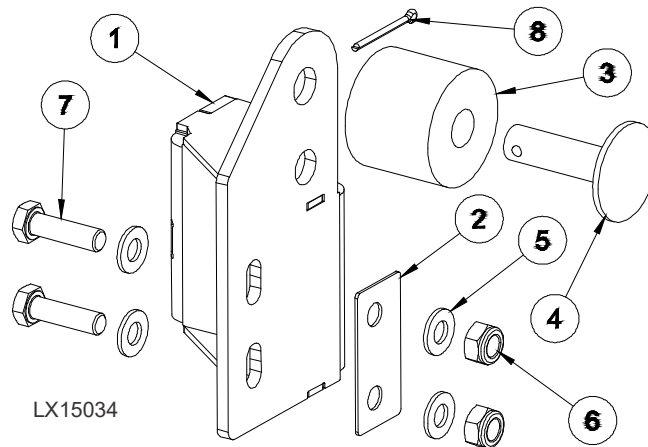

REF	DESCRIPTION (◆ Indicates Parts Available In Assemblies Only)	PART #	QTY.
	BED STOP ASSEMBLY, FRONT RIGHT	517896	1
1	Plate, Bed Stop	517901-1	1
2	Plate, Bed Stop Shim	515061-1	1
3	Bushing, Bed Stop	P12165	1
4	Bolt, Bed Stop	086182-1	1
5	Pin, Roll S-Zn 4x25 PN-M/82001	F81043-2	1
6	Washer, Flat 10,5 Fe/Zn5 PN-78/M-82005	F81055-1	4
7	Nut, M10-8-B -Fe/Zn PN-M82175	F81033-1	2
8	Bolt, M10x35-8.8 Fe/Zn5 PN-M/82105	F81003-17	2

SECTION 9 MISCELLANEOUS

9.1 Replacement Manuals



REF	DESCRIPTION (◆ Indicates Parts Available In Assemblies Only)	PART #	QTY.
Wood-Mizer Product Information			
1	ALL-PRODUCTS CATALOG	PS750	1
Basic Sawmill Manuals			
2	TRU-SHARP BLADE HANDBOOK	M600	1
3	WOOD-MIZER GENERAL INFORMATION	M601	1
4	LX150 OPERATOR'S MANUAL	M2272	1
5	LX150 PARTS MANUAL	M2274	1
Power Option Manuals			
6	G25 ENGINE OPTION MANUAL	M2276	1
Miscellaneous Manuals			
7	SHINGLE/LAPSIDER MANUAL (OPTION)	M621	1
8	RESAW ATTACHMENT MANUAL (OPTION)	M263	1
9	LATHE-MIZER MANUAL (OPTION)	M1337	1
Electrical Diagrams			
10	ELECTRICAL INFORMATION (G25)	M2278	1