

Wood-Mizer[®] Sawmill

Parts Manual

LX150

rev. A3.01



Safety is our #1 concern! Read and understand all safety information and instructions before operating, setting up or maintaining this machine.

Form #2274

California
Proposition 65 Warning



WARNING: Breathing gas/diesel engine exhaust exposes you to chemicals known to the State of California to cause cancer and birth defects or other reproductive harm.

Always start and operate the engine in a well-ventilated area.
If in an enclosed area, vent the exhaust to the outside.
Do not modify or tamper with the exhaust system.
Do not idle the engine except as necessary.

For more information go to **www.P65warnings.ca.gov**.



WARNING: Drilling, sawing, sanding or machining wood products can expose you to wood dust, a substance known to the State of California to cause cancer. Avoid inhaling wood dust or use a dust mask or other safeguards for personal protection.

For more information go to **www.P65Warnings.ca.gov/wood**.

Active Patents assigned to Wood-Mizer, LLC

Wood-Mizer, LLC has received patents that protect our inventions which are a result of a dedication to research, innovation, development, and design. Learn more at: woodmizer.com/patents

©2024 Wood-Mizer LLC

Printed in the United States of America, all rights reserved. No part of this manual may be reproduced in any form by any photographic, electronic, mechanical or other means or used in any information storage and retrieval system without written permission from

Wood-Mizer, LLC
8180 West 10th Street
Indianapolis, Indiana 46214

Table of Contents

Section-Page

SECTION 1	REPLACEMENT PARTS	1-1
1.1	How To Use The Parts List1-1 <i>To Order Parts</i>	
1.2	Sample Assembly1-1	
1.3	Torque Values1-2	
SECTION 2	BLADE GUIDE ROLLERS & ARM	2-1
2.1	Blade Guide Arm Assembly2-1	
2.2	Blade Guide Arm Drive Assembly2-3	
2.3	Blade Guide Arm Drive Sprocket Assembly2-4	
2.4	Blade Guide Assembly, Drive Side2-5	
SECTION 3	BLADE WHEELS & TENSIONER	3-1
3.1	Blade Drive Assembly3-1	
3.2	Idle Blade Wheel Assembly3-2	
3.3	Blade Tensioner Assembly3-3	
SECTION 4	SAW HEAD FRAME	4-1
4.1	Water Lube Assembly4-1	
4.2	Brake Assembly4-1	
4.3	Clutch Assembly4-3	
4.4	Saw Head Decals4-5	
4.5	Blade Housing Covers & Saw Head Hardware4-7	
SECTION 5	CONTROL & BATTERY BOXES	5-1
5.1	Control Box Assembly5-1	
5.2	Control Box Mount & Up/Down Limit Switches5-3	
5.3	Drum Switches5-4	
5.4	Circuit Breakers5-5	
5.5	Front Panel Assembly & Harnesses5-6	
5.6	Fuse Box5-7	
5.7	Battery Box Assembly5-8	
SECTION 6	UP/DOWN SYSTEM	6-1
6.1	Mast Pad & Hardware6-1	
6.2	Blade Height Scales & Mast Angles6-2	
6.3	Head Mounting Assembly6-3	
6.4	Up/Down Assembly6-4	
SECTION 7	FEED SYSTEM & TRACK ROLLERS	7-1
7.1	Track Rollers and Wipers (Drive Side)7-1	
7.2	Track Roller And Wipers (Idle Side)7-3	
7.3	Power Feed Assembly7-5	
7.4	Travel Lock Assembly7-7	

Table of Contents

Section-Page

SECTION 8	BED FRAME ASSEMBLY	8-1
8.1	Bed Frame Assembly	8-1
8.2	Bed Section Assembly.....	8-2
8.3	Bed Section Assembly, Front	8-3
8.4	Bed Stop Assembly, Front Left.....	8-4
8.5	Bed Stop Assembly, Rear Left.....	8-5
8.6	Bed Stop Assembly, Rear Right.....	8-6
8.7	Bed Stop Assembly, Front Right.....	8-7
SECTION 9	MISCELLANEOUS	9-1
9.1	Replacement Manuals	9-1

SECTION 1 REPLACEMENT PARTS

1.1 How To Use The Parts List

- Use the table of contents to locate the assembly that contains the part you need.
- Go to the appropriate section and locate the part in the illustration.
- Use the number pointing to the part to locate the correct part number and description in the table.
- Parts shown indented under another part are included with that part.

To Order Parts

- From the continental US, call **1-800-525-8100** to order parts. Have your customer number, vehicle identification number, and part numbers ready when you call.
- From other international locations, contact the Wood-Mizer distributor in your area for parts.

1.2 Sample Assembly



REF	PART #	DESCRIPTION	COMMENTS	QTY.
	012345	SAMPLE ASSEMBLY, COMPLETE	INCLUDES ITEMS 1-6	1
1	F02222-22	Sample Part		1
2	F03333-33	Sample Part		2
	098765	Sample Subassembly	Includes items 3-6	1
3	S04444-44	Subassembly Sample Part		1
4	K55555	Subassembly Sample Part		1
	054321	Sample Sub-Subassembly	Includes items 5-6	2
5	022222	Sub-Subassembly Sample Part		1
6	F10234-56	Sub-Subassembly Sample Part		1

The Sample Assembly, Complete, part number 02345 (top level assembly) includes two parts (F0222-22 and F0333-33) and the 098765 subassembly.

Subassembly 098765 contains two parts(S04444-44 and K55555) and two copies of sub-subassembly 054321.

Each sub-subassembly 054321 contains two parts (022222 and F10234-56).

1.3 Torque Values

Grade		Units	SAE 5	SAE 8
Grade Mark				
Bolt Dia.	Threads. Per In.	Units	SAE 5	SAE 8
6	32	in-lbs (Nm)	20 (2.3)	-
8	32	in-lbs (Nm)	24 (2.7)	30 (3.4)
10	24	in-lbs (Nm)	35 (4.0)	45 (5.1)
10	32	in-lbs (Nm)	40 (4.5)	50 (5.7)
12	24	in-lbs (Nm)	50 (5.7)	65 (7.3)
1/4	20	in-lbs (Nm)	95 (10.7)	125 (14.1)
1/4	28	in-lbs (Nm)	95 (10.7)	150 (17.0)
5/16	18	ft-lbs (Nm)	17 (22.6)	23 (31.2)
5/16	24	ft-lbs (Nm)	20 (27.1)	25 (33.8)
3/8	16	ft-lbs (Nm)	30 (40.7)	40 (54.2)
3/8	24	ft-lbs (Nm)	35 (47.5)	45 (61.0)
7/16	14	ft-lbs (Nm)	50 (67.8)	65 (88.1)
7/16	20	ft-lbs (Nm)	55 (74.6)	70 (94.9)
1/2	13	ft-lbs (Nm)	75 (101.7)	100 (135.6)
1/2	20	ft-lbs (Nm)	85 (115.3)	110 (149.2)
9/16	12	ft-lbs (Nm)	105 (142.4)	135 (183.1)
9/16	18	ft-lbs (Nm)	115 (155.9)	150 (203.4)
5/8	11	ft-lbs (Nm)	150 (203.4)	195 (264.4)
5/8	18	ft-lbs (Nm)	160 (217.0)	210 (284.8)
3/4	10	ft-lbs (Nm)	170 (230.5)	220 (298.3)
3/4	16	ft-lbs (Nm)	175 (237.3)	225 (305.1)
7/8	9	ft-lbs (Nm)	302 (409.5)	473 (640.9)
7/8	14	ft-lbs (Nm)	300 (406.8)	400 (542.4)
1	8	ft-lbs (Nm)	466 (631.8)	714 (967.4)

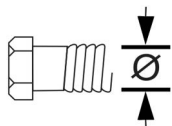

Metric Bolt Head Identification



Metric Grade 8.8



Metric Grade 10.9

COARSE THREAD					FINE THREAD					Wrench Size
Diameter & Thread Pitch	Metric 8.8		Metric 10.9		Diameter & Thread Pitch	Metric 8.8		Metric 10.9		
	N-m	lbs-ft	N-m	lbs-ft		N-m	lbs-ft	N-m	lbs-ft	
6 x 1.0	8	6	11	8						10 mm
8 x 1.25	20	15	27	20	8 x 1.0	21	16	29	22	13 mm
10 x 1.5	39	29	54	40	10 x 1.25	41	30	57	42	16 mm
12 x 1.75	68	50	94	70	12 x 1.25	75	55	103	76	18 mm
14 x 2.0	109	80	151	111	14 x 1.5	118	87	163	120	21 mm
16 x 2.0	169	125	234	173	16 x 1.5	181	133	250	184	24 mm
18 x 2.5	234	172	323	239	18 x 1.5	263	194	363	268	27 mm
20 x 2.5	330	244	457	337	20 x 1.5	367	270	507	374	30 mm
22 x 2.5	451	332	623	460	22 x 1.5	495	365	684	505	34 mm
24 x 3.0	571	421	790	583	24 x 2.0	623	459	861	635	36 mm
30 x 3.0	1175	867	1626	1199	30 x 2.0	1258	928	1740	1283	46 mm

SECTION 2 BLADE GUIDE ROLLERS & ARM

2.1 Blade Guide Arm Assembly

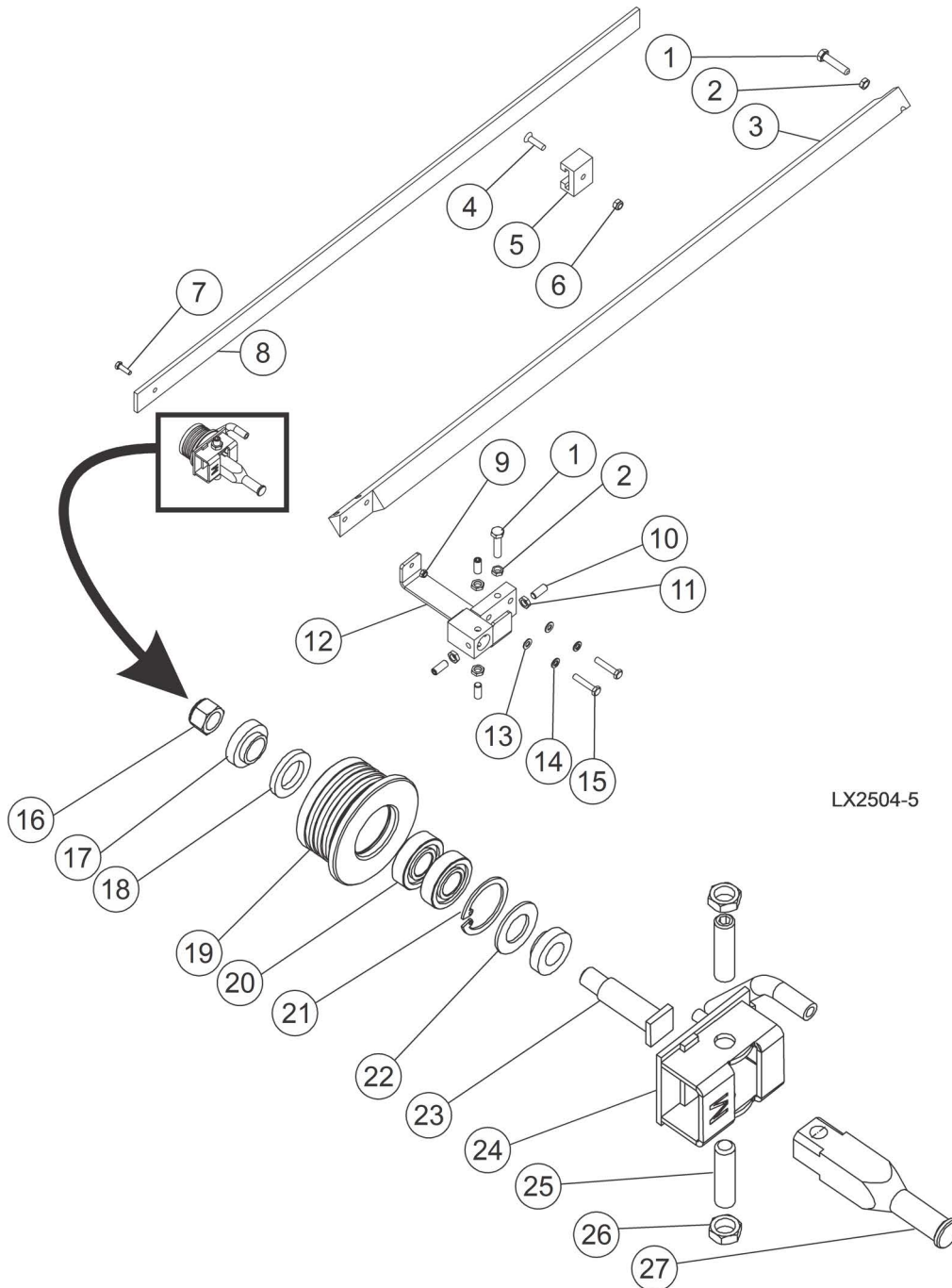

LX2504-5

REF	PART #	DESCRIPTION	COMMENTS	QTY.
	110926	ARM ASSY, LX BLADE GUIDE		
1	F05022-44	Bolt, M10-1.5 x 45 HH 8.8		2
2	F05027-18	Nut, M10-1.5 Jam		2
3	110927	Bar, LX Blade Guide		1

REF	PART #	DESCRIPTION	COMMENTS	QTY.
4	F05004-245	Screw, M8x1.25x30mm Flat Socket C/S BO		1
5	014882	Guide, Blade Guard LT15/LT70		1
6	F05010-132	Nut, M8-1.25 Hex Nylock		1
7	F81001-2	Bolt, M6-1x20mm 8.8 Hex Head		1
8	110934	Guard, LX Blade		1
9	F05010-200	Nut, M6-1.0 Nylon Lock		1
10	F81015-4	Screw, M10-1x25mm Stainless Set, DIN 913		4
11	F81033-10	Nut, M10x1-04-ST-A2 ISO 8675 Thin		4
12	110929	Block Weldment, LX Blade Guide		1
13	F05026-4	Washer, M8 Flat		2
14	F05011-45	Washer, M8 Split Lock		2
15	F81002-15	Bolt, M8-1.25x40 HH FT Zinc Class 8.8		2
	130842	Assy, Metric Idle Blade Guide		1
16	F05004-270	Nut, M10-1.50 Hex Nyl Lock		1
17	S04253	Spacer, .510x.937x.34		2
18	P06455	Washer, 5/8 Grey Felt		1
19	A09678	Roller Assy, Blade Guide		1
20	S04250	Roller, Blade Guide		1
21	015975	Bearing, R8-2RS Blade Guide		2
22	F04254-1	Ring, 1 1/8 IR Tru-Ark		1
23	P04252	Washer, 5/8 White Felt		1
24	087763_US	Shaft, M10-1.5 Metric Roller		1
25	130841	Weldment, Metric Idle B/G Brkt		1
26	F05022-57	Screw, M10-1.5x40mm SH Set, SS, Cup Pnt		2
27	F05010-203	Nut, M10-1.5 Hex Fin Jam- DIN 439 B Zinc		2
28	503588_US	Shaft, Metric B/G Mount		1

2.2 Blade Guide Arm Drive Assembly

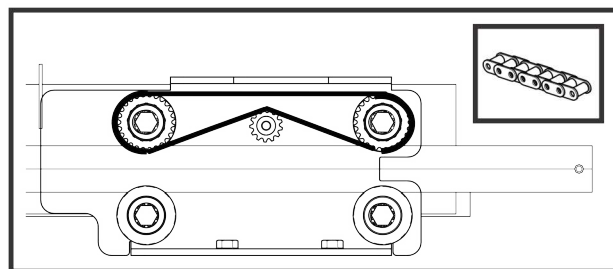
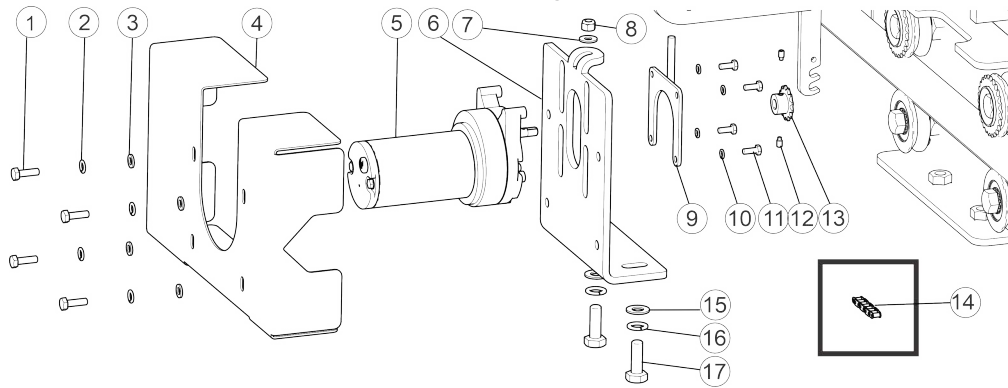

TD011003

REF	PART #	DESCRIPTION	COMMENTS	QTY.
	110918	DRIVE ASSY, LX BLADE GUIDE		
1	F05020-6	Bolt, M6-1 x 20 Class 8 HH		4
2	F05026-2	Washer, M6 Split Lock		4
3	F05026-1	Washer, M6 Flat Class 4		4
4	110923	Guard, Blade Guide		1
5	079214	Motor, Current App 1/30HP 12VDC Gear		1
6	110919	Weldment, LX Blade Guide Drive		1
7	F05011-11	Washer, 1/4 SAE Flat		1
8	F05010-69	Nut, 1/4-20 Nylock		1
9	023637	Tensioner Weldment, Gearmotor Ptd		1
10	F05011-20	Washer, #10 Split Lock		4
11	F05004-60	Bolt, #10-32x1/2 HH		4
	P09970	Sprocket Assy, 25B13x.3130		1
12	F05004-274	Screw, 10-24x1/4 SHBO Full Dog Pt Set		2
13	P09970-2	Sprocket, 25B13x.3130		1
14	130315	Chain, #25 100 Pitches w/Master Link (not shown)		1
15	F05011-134	Washer, M10 Flat		2
16	F05011-88	Washer, 10MM Split Lock		2
17	F05022-3	Bolt, M10-1.5x30 HH Class 8		2

2.3 Blade Guide Arm Drive Sprocket Assembly

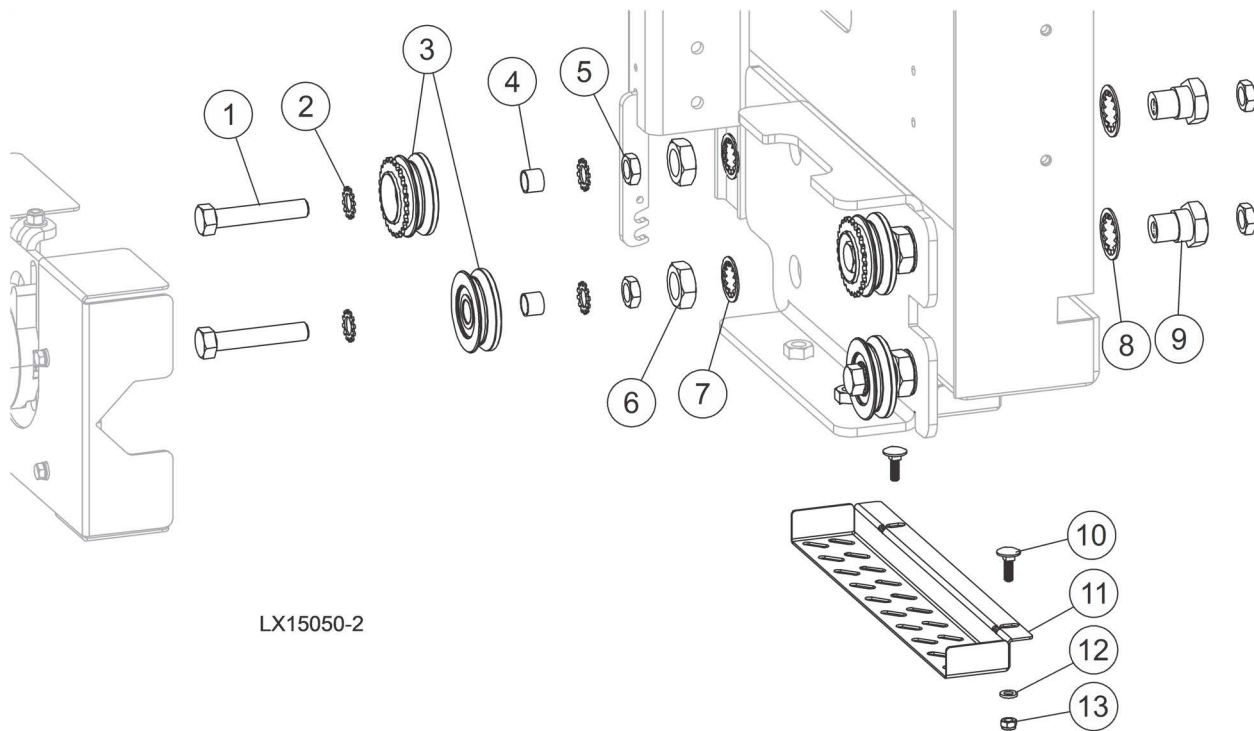

REF	PART #	DESCRIPTION	COMMENTS	QTY.
	130316	ASSY, LX V-GROOVE DRIVEN ECCENTRIC		2
	130317	ASSY, LX V-GROOVE IDLE ECCENTRIC		2
1	F05008-185	Bolt, 1/2-13x2 3/4 HH FT Gr8		1
2	F05011-39	Washer, 1/2 Star ET		2
3	A09932	Roller Assy, Blade Guide Arm Drive (130316 only)		1
4	A09059	Roller Assembly, V-Groove (130317 only)		1
5	110979	Sleeve, LX B/G		1
6	F05010-31	Nut, 1/2-13 Jam		2
7	F05010-67	Nut, 3/4-16 Jam		1
8	F05011-148	Washer, 3/4 Star IT		1
9	F05011-73	Washer, 7/8 Star IT		1
10	110978	Nut, 1/2-13 Eccentric		1
11	F05020-58	Bolt, M6-1 x 20 CARRIAGE		2
12	130314	Plate, LX B/G System Lower Cover		1
13	F05026-1	Washer, M6 Flat Class 4		2
14	F05010-200	Nut, M6-1.0 Nylon Lock		2

2.4 Blade Guide Assembly, Drive Side

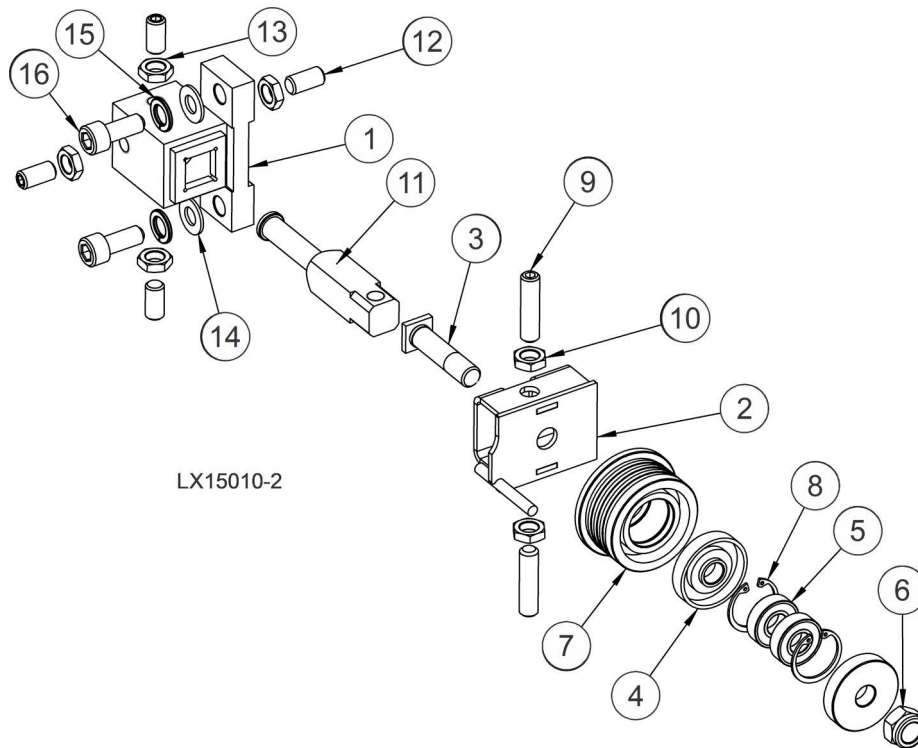

REF	PART #	DESCRIPTION	COMMENTS	QTY.
1	087744_US	Mount Weldment, Blade Guide		1
	094682_US	Guide Assembly, Blade		1
2	094679-1	Bracket, Blade Guide Drive Side		1
	087887	Roller, Blade Guide w/Bearings		1
3	087763-1	Bolt, Blade Guide		1
4	087891-1	Ring, Blade Guide Roller Zinc		2
5	087893	Bearing, 6001 2rsr (Fag, Skf).		2
6	F81034-2	Nut, M12 8 Fe/zn5		1
7	087889	Roller, Blade Guide		1
8	F81090-9	Ring, Retaining W28 Pn/m-85111.		2
9	F81015-2	Screw, Set M10x1x40 Din913 A2-70.		2
10	F81033-10	Nut, M10x1 Iso8675		2
11	503588-1	Shaft, Roller Complete		1
12	F81015-1	Screw, M10x1x20 DIN913 Stainless Set		4
13	F81033-10	Nut, M10x1-04-ST-A2 ISO 8675 Thin		4
14	F05011-134	Washer, M10 Flat		2
15	F05011-88	Washer, 10MM Split Lock		2
16	F05022-12	Bolt, M10-1.5 x 25 SHC		2

SECTION 3 BLADE WHEELS & TENSIONER

3.1 Blade Drive Assembly

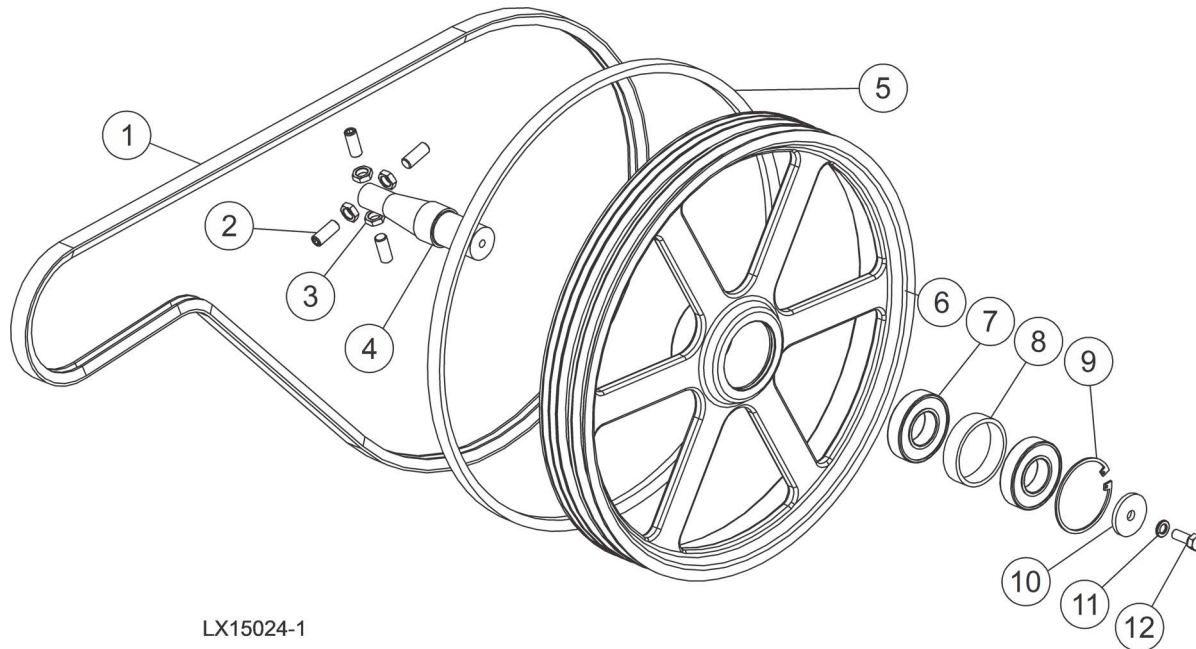

REF	PART #	DESCRIPTION	COMMENTS	QTY.
1	047751	Belt, 2/3VFL900 Drive		1
2	F81016-1	Screw, M12x1.25x30 DIN913 Stainless Set		4
3	F81034-9	Nut, M12x1.25 DIN439 Thin Stainless		4
4	014729	Shaft, LT15 Drive		1
5	P04185	Belt, B-57		1
	036657	WHEEL ASSEMBLY, LT15 3V DRIVE		1
6	047702	Sheave, 3V LT15 Drive		1
7	014811	Bearing, 6207-2RS, C3, 35x72x17		2
8	014730	Spacer, Drive Bearing LT15		1
9	F04254-30	Ring, 72MM OD Retaining N5002-281		1
10	014728	Washer, LT15 Drive Wheel Ret.		1
11	F05011-4	Washer, 3/8 Split Lock		1
12	F05007-87	Bolt, 3/8-16x1 Gr5 HH		1

3.2 Idle Blade Wheel Assembly

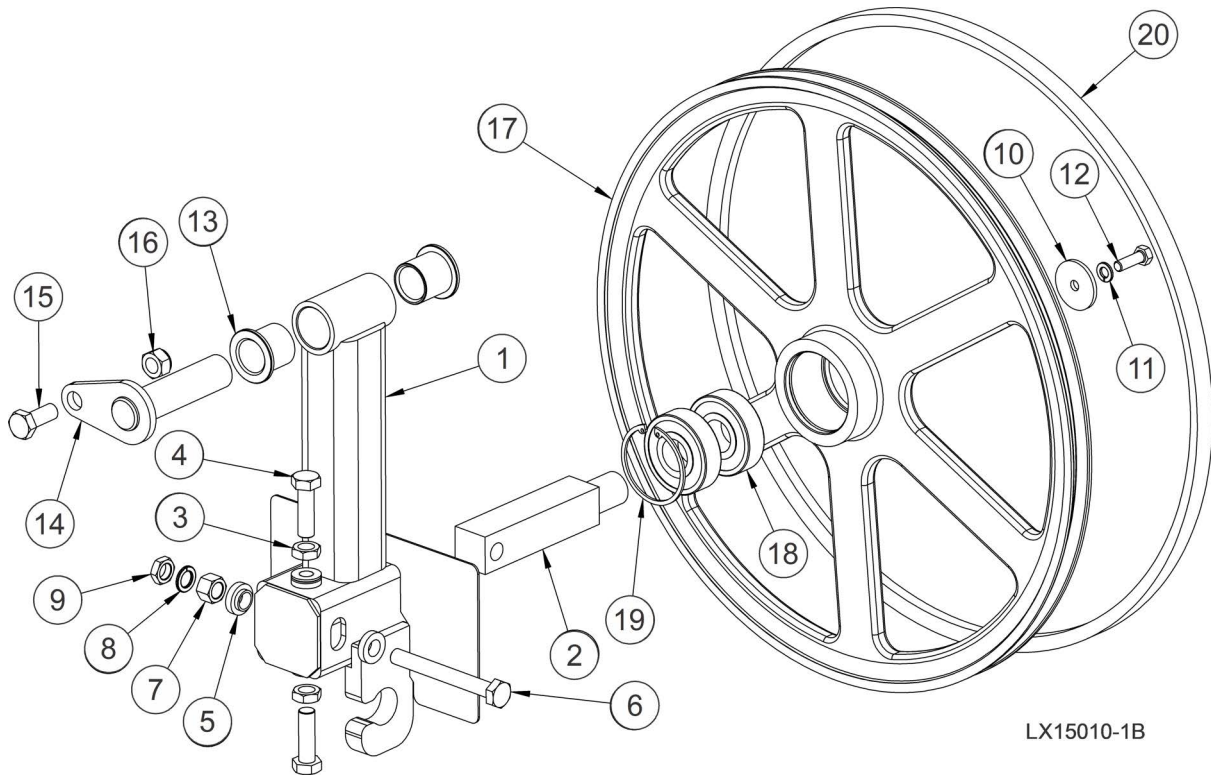

LX15010-1B

REF	PART #	DESCRIPTION	COMMENTS	QTY.
	011267	Assembly, LX150 Blade Wheel Idler		1
1	011268	Weldment, LX150 Blade Wheel Idler		1
2	096045	Shaft, 30mm Sq Idler		1
3	F05027-19	Nut, M12-1.75 Zinc Jam		2
4	F05004-250	Bolt, M12x1.75x40mm Hex Head FT CL10.9 Zinc		2
5	S04253	Spacer, .510x.937x.34		2
6	F81004-41	Bolt, M12x1.25x100 Gr8.8 Hex Head Full Thread		1
7	F81034-8	Nut, M12x1.25 8.8 Hex Zinc		1
8	F05011-123	Washer, 12MM Split Lock		1
9	F81034-5	Nut, M12x1.25 8.8 Hex Zinc Thin		1
10	S08220	Washer, .313x1.5x.125		1
11	F05011-45	WASHER, 8MM SPLIT LOCK, ZN		1
12	F05004-40	Bolt, M8x1.25x25 Hex Head FT		1
13	P109	Bushing, 1 IDx1-1/4 ODx1-1/4 FI		2
14	042232	Pin Weldment, Side Support		1
15	F05008-175	Bolt, M12x1.75x30mm Hex Head Znc		1
16	F05010-209	Nut, M12x1.75 Hex Nylock		1
	A08218	Sheave Assembly, 19 Idler		1
17	P08125	Sheave, 18.62 Idler		1
18	P08066	Bearing, .9843x2.4409x.6693		2
19	F04254-21	Snap Ring, 2 7/16 IR Beveled		1
20	P04185	BELT, B-57		1

3.3 Blade Tensioner Assembly

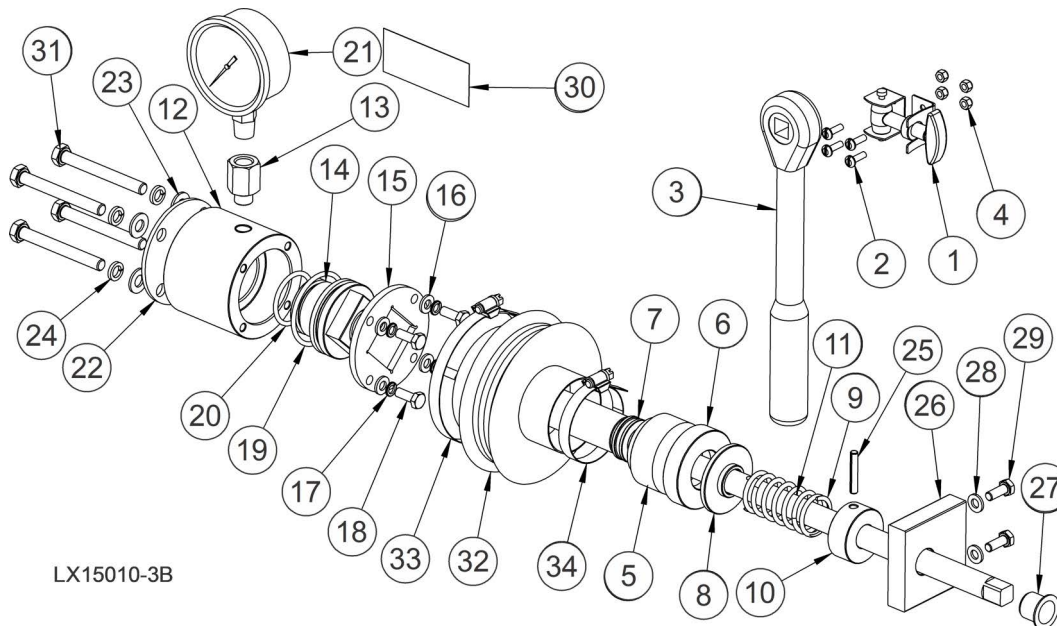

REF	PART #	DESCRIPTION	COMMENTS	QTY.
1	011360	Latch, Tool Retaining		1
2	F05004-74	Screw, 4mx12 CrSI Round Head Machine		4
3	091620	Tool, Blade Tensioning		1
4	F05027-8	Nut, M4-.7 Class 8 Nylock		4
	510640	Tensioner, LX150 Blade		1
5	510635	Housing, Round		1
6	510634-1	Ring, Round		1
7	086675	Bearing, 51103		1
8	510633-1	Washer, Blade Tensioner		1
9	088992	Spring, 60x23x3		1
10	510636-1	Bushing, 16/38-20 22.5-4 Zinc		1
11	510650-1	Bolt, Blade Tensioner Zinc		1
	510641	Cylinder, Complete		1
	510657-1	Cylinder Assembly, Reduction		1
12	510637	Cylinder		1
13	513280	Fitting, Z-m12x1/w-1/4npt		1
14	510638	Piston, Blade Tensioner		1
15	510490-1	Plate, Tensioner		1
16	F81053-1	Washer, 6.4 FE/ZN5 PN-78/M-82005		4
17	F81053-3	Washer, Split Lock Z 6.1		4
18	F81001-15	Bolt, M6x16-8.8-FE/ZN5 PN-M/82105		4
19	510646	Ring, 46.2x3		1
20	510647	Ring, 32.2x3		1
21	505176	Gauge, Oil Pressure 200 Bar (3000psi)		1
22	510642-1	Cover, Tensioner		1
23	F81054-1	Washer, 8.4 FE/ZN5 PN-78/M-82005		4

REF	PART #	DESCRIPTION	COMMENTS	QTY.
24	F81054-4	Washer, Split Lock M8 Fe/zn5 Pn-m/82008		4
25	F81044-21	Pin, Roll 5x30 FE/ZN5 PN/M-85023.		1
26	096730	Bracket, Blade Tensioner		1
27	089589	Bushing, GFM-1618-17		1
28	F81053-1	Washer, 6.4 FE/ZN5 PN-78/M-82005		2
29	F81001-15	Bolt, M6x16-8.8-FE/ZN5 PN-M/82105		2
30	510643	Decal, Pressure Settings		1
31	F81002-71	Bolt, M8x70 8.8 Hex Head Zinc		4
	515050	Cover, Blade Tensioner Complete		1
32	515051	Cover, Blade Tensioner		1
33	F81095-5	Clamp, 70-80 Mm.		1
34	F81095-4	Clamp, 40-60 Mm.		1

SECTION 4 SAW HEAD FRAME

4.1 Water Lube Assembly

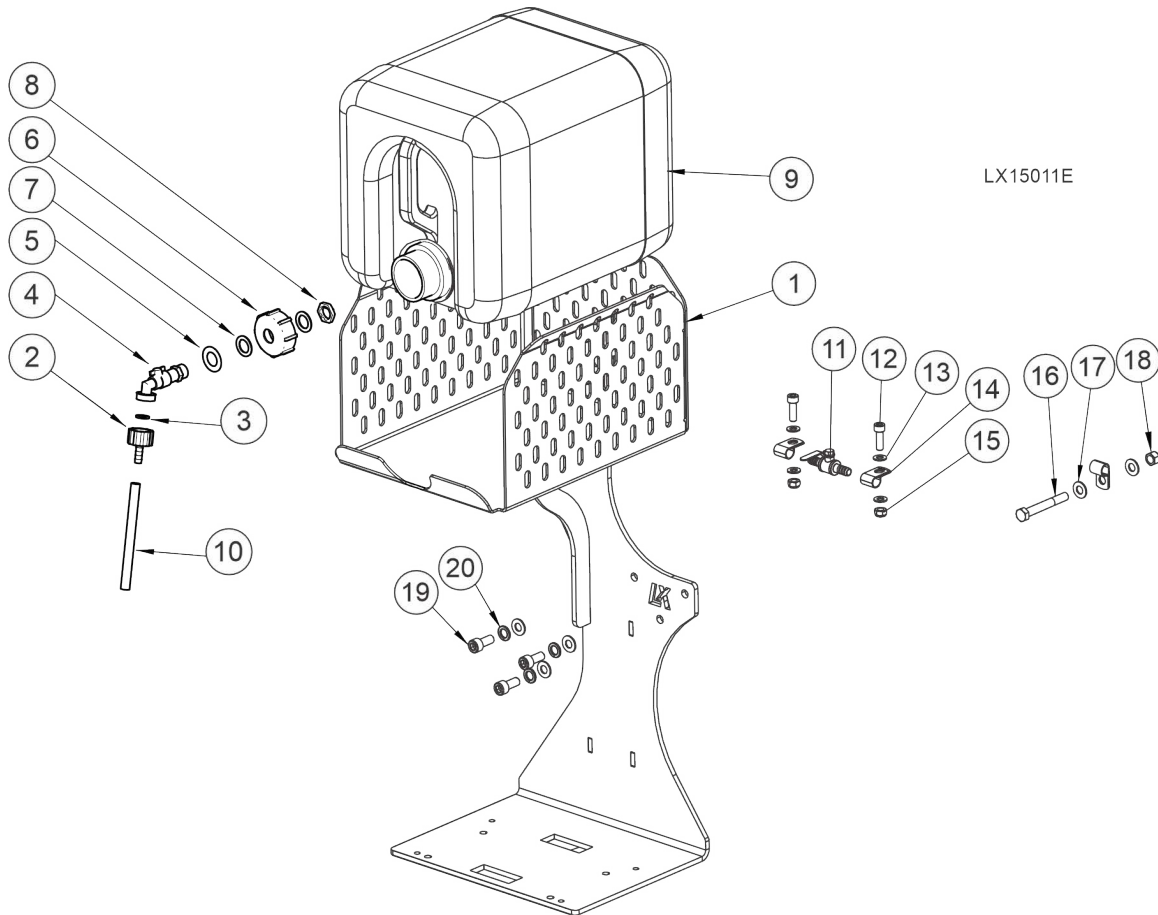

REF	PART #	DESCRIPTION	COMMENTS	QTY.
	011231	Tray Assembly, LX150 Water Bottle		1
1	011171	Weldment, Battery/Water Mounting		1
	550787	Assembly, Water Bottle		1
2	550777	Fitting, G3/4" X 10mm Hose Barb		1
3	550778	Gasket, 1/2 (Batard)		1
4	550776	Fitting, Water Lube Shutoff Valve		1
5	530841	Shim, 21/37-1		1
6	550785	Cap. Water Bottle		1
7	550780	O-ring, 27x20x1.5		2
8	550779	Gland Nut, 1/2 Npt		1
9	513866	Bottle, Water		1

REF	PART #	DESCRIPTION	COMMENTS	QTY.
10	R01885	Hose, Water Lube Stock		1
11	065635	Valve, 1/4Turn Ball 3/8 Hose Barbs		1
12	F05021-33	Screw, M8-1.25x25 SHC BO		2
13	F05026-4	Washer, M8 Flat		4
14	P07584	Clamp, 1/2EMT Coated		3
15	F05010-132	Nut, M8-1.25 Hex Nylock		2
16	F05022-15	Bolt, M10-1.5x75 Hex Head Class 8.8		1
17	F05011-134	Washer, M10 Flat		5
18	F05004-270	Nut, M10-1.50 Hex Nyl Lock		1
19	F05022-12	Bolt, M10-1.5x25 SHC		3
20	F05011-88	Washer, 10mm Split Lock		3

4.2 Brake Assembly

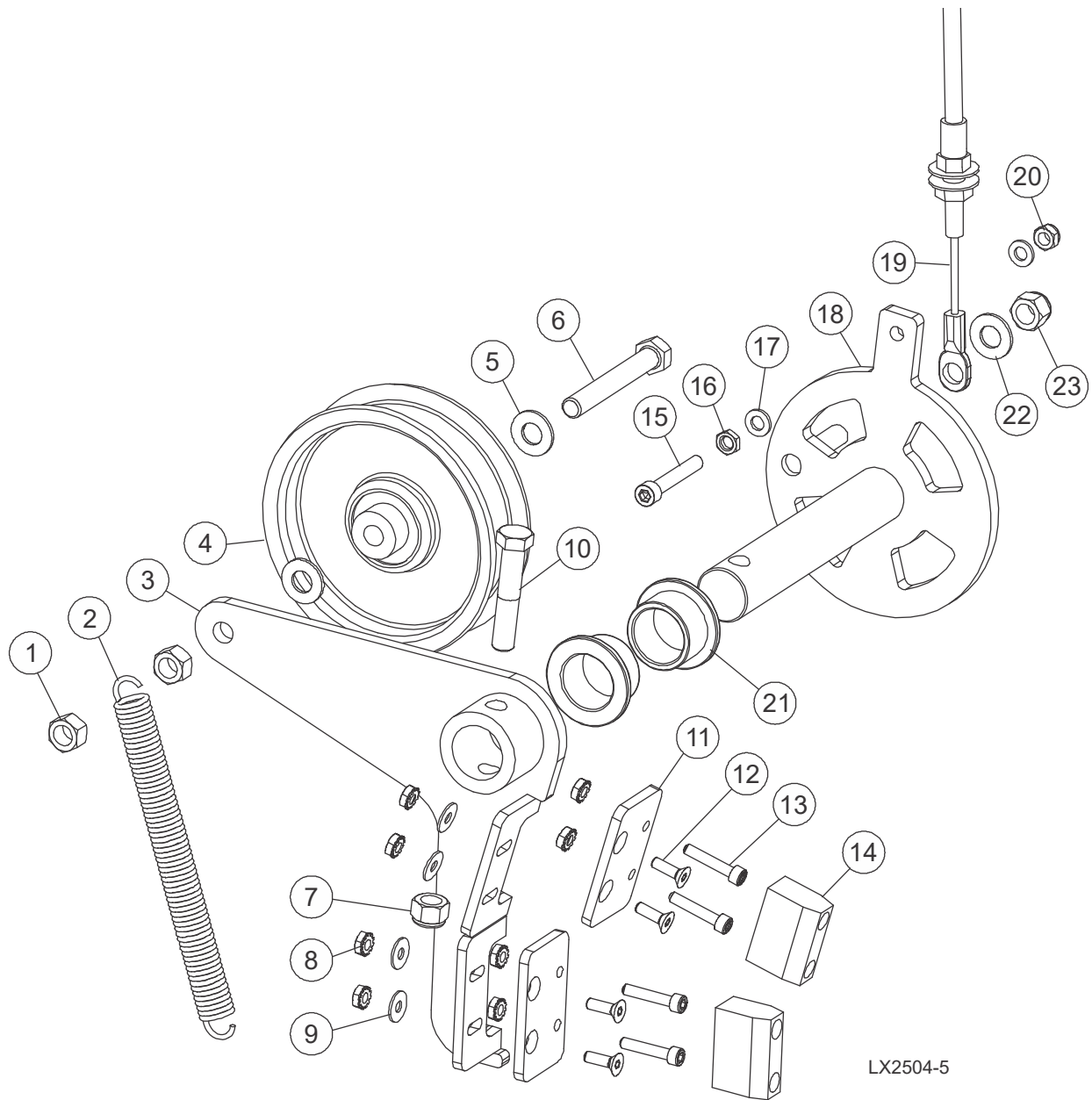

LX2504-5

REF	PART #	DESCRIPTION	COMMENTS	QTY.
	065874	Assy, Brake/Clutch		
1	F05010-25	Nut, 3/8-16 Swaged Lock		2
2	034810	Spring, Idler Arm LT15/D/E/G		1
3	065873	Weldment, Clutch/Brake Arm		1
4	034602	Idler, 4" O.D.x 3/8 Bore		1
5	F05011-3	Washer, 3/8 Flat SAE		2
6	F05007-230	Bolt, 3/8-16x2 3/4 FT Gr5		1
7	F05010-10	Nut, 3/8-16 Hex Nyloc		1

REF	PART #	DESCRIPTION	COMMENTS	QTY.
8	F05010-14	Nut, #10-24 Keps->		8
9	F05011-18	Washer, #10 SAE Flat		4
10	F05007-124	Bolt, 3/8-16X2 HH GR5		1
11	065872	Plate, Brake Adjustment		2
12	F05004-282	Screw, 10-24x5/8 FSHC BO		4
13	F05004-2	Bolt, 10-24x1 BO SHC		4
14	016488	Block, LT15 Brake		2
15	F05004-284	Bolt, M6-1.0x40mm SHCS		1
16	F0501-0-226	Nut, M6x1 Metric Jam		1
17	F05026-1	Washer, M6 Flat Class 4		2
18	011187	Weldment, LX150 Clutch/Brake Pivot		1
19	011131	Cable, .140"x69" Throttle		1
20	F05010-200	Nut, M6-1.0 Nylon Lock		1
21	P737	Bushing, 1x1 1/4x3/4 Flg Bronze		2
22	F05011-3	Washer, 3/8 Flat SAE		1
23	F05010-10	Nut, 3/8-16 Hex Nyl Lock		1

4.3 Clutch Assembly

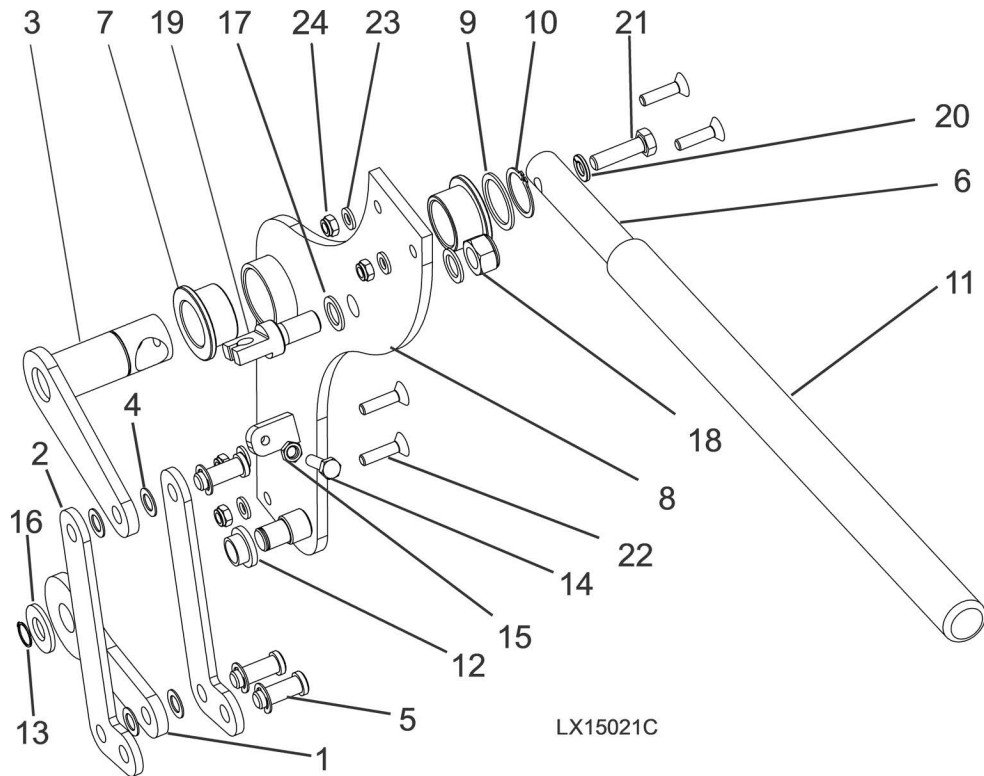

REF	PART #	DESCRIPTION	COMMENTS	QTY.
	011219	Assembly, LX150 Clutch		1
1	011215	Plate, LX150 Clutch Pivot Arm		1
2	011214	Plate, LX150 Clutch Engagment Arm		2
3	011132	Weldment, LX150 Throttle Engagement		1
4	033444	Washer, 3/8 ID 5/8 OD .032 Thick Nylon		4
5	F05012-154	Pin, 3/8x13/16 Clevis, Stainless		3
6	011217	Handle, LX150 Clutch Engagment		1
7	P737	Bushing, 1x1 1/4x3/4 Flg Bronze		2
8	011193	Weldment, LX150 Clutch Hub		1
9	F05011-116	Washer, 1 ID .06 SS Shim	F05011-116 replaced 076037 after 1/27/2022 per ECN 38339.	1
	076037	Shim, 1 ID 1-1/4 OD		1
10	F04254-15	Ring, 1 OR		1
11	028390	Grip, Handle		1
12	049007	Bushing, 1/2IDx5/8ODx3/8 Long FI		1
13	F04254-18	Ring, Shaft 1/2 In, Retaining		1
14	F05020-33	Bolt, M6-1 x 25 Class 8 Hex Head		1
15	F05010-226	Nut, M6x1 Metric Jam		1
16	F05011-2	Washer, 1/2 SAE Flat		1
17	P05251-1	Washer, 1/2x3/4x1/16 Nylon		2
18	F05010-209	Nut, M12x1.75 Hex Nylock		1

REF	PART #	DESCRIPTION	COMMENTS	QTY.
19	011235	Bolt, LX150 Throttle Pivot		1
20	F05011-45	Washer, 8mm Split Lock, Zn		1
21	F05021-11	Bolt, M8-1.25x30mm Hex HeadC FT		1
22	F05004-266	Screw, M6x1x25mm FHS		4
23	F05026-1	Washer, M6 Flat Class 4		4
24	F05010-200	Nut, M6-1.0 Nylon Lock		4
		See your specific engine manual for clutch cable P/N		

4.4 Saw Head Decals

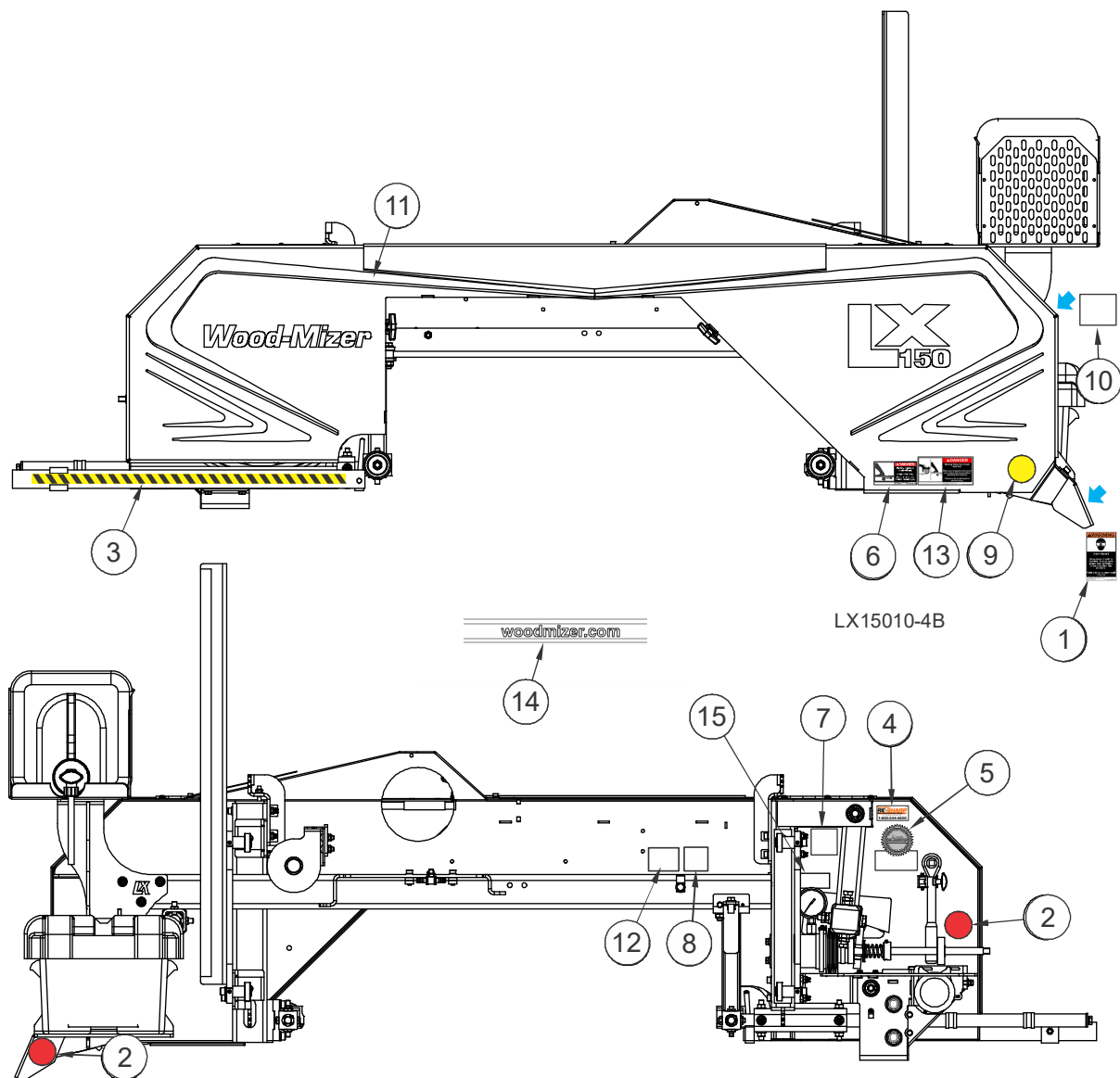

REF	PART #	DESCRIPTION	COMMENTS	QTY.
1	P11754	DECAL, SAWDUST CHUTE WARNING		1
2	P07452	DECAL, RED REFLECTIVE 2" ROUND		2
3	015849	DECAL, BLADE GUIDE ARM STRIPE		1
4	P12879	DECAL, BLADE RESHARP INFO		1
5	079278	DECAL, WOOD-MIZER QUALITY & INFORMATION		1
6	S11752	DECAL, BLADE DANGER		1
7	P11789	DECAL, BLADE ALIGNMENT		1
8	P11790	DECAL, TENSION SCREW		1
9	P07453	DECAL, AMBER REFLECTIVE 2" ROUND		1

REF	PART #	DESCRIPTION	COMMENTS	QTY.
10	074008	DECAL, BUILT IN THE USA		1
11	011141	DECAL, LX150 BLADE COVER		1
12	P10147	DECAL, HYDRAULIC BLADE TENSION CAUTION		1
13	033254	DECAL, BLADE COVERS DANGER		2
14	107170	DECAL, WHITE WOODMIZER.COM (LOCATED ON POWER FEED TUBE)		1
15	128179	DECAL, TENSION		1

4.5 Blade Housing Covers & Saw Head Hardware

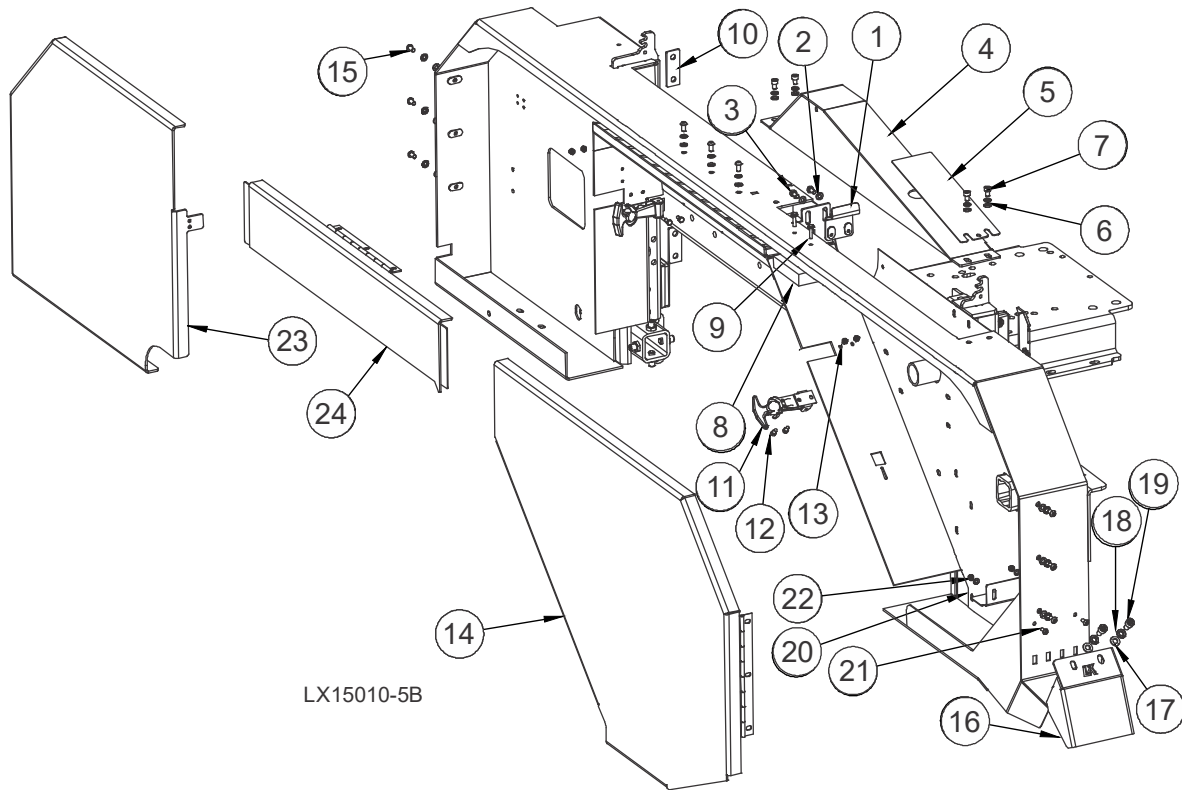

REF	PART #	DESCRIPTION	COMMENTS	QTY.
1	011242	BRACKET WELDMENT, LX150 BELT ENHANCE		1
2	F05026-1	WASHER, M6 FLAT CLASS 4		15
3	F05005-99	SCREW, M6-1X12 HEX HEADC FT		2
4	076656	WELDMENT, LX150 TOP BELT COVER		1
5	074546	PLATE, BELT GUARD COVER		1
6	F05026-2	WASHER, M6 SPLIT LOCK		13
7	F05020-19	SCREW, M6-1 X 10 SHC		4
8	015844	PAD, BLADE VIBRATION		1
9	F05015-33	SCREW, #10X3/4 SL HEX WAS HEAD SCR		2
10	110599	SHIM PLATE, MAST ROLLERS		2
11	014829	LATCH, FLEXIBLE DRAW		2
12	F05004-259	SCREW, M5-0.8X16MM SHCS SS		4
13	F05027-3	NUT, M5-.8 CLASS 8 HEX NYLOC		6
14	117076	WELDMENT, COVER RIGHT	Cover Weldment 011074 was replaced by Cover Weldments 117076, 011416, and 110992 on 5/6/2019.	1
15	F05004-275	SCREW, M6-1.0 X 12MM BHCS BLACK OXIDE		9
16	011243	PLATE, LX150 SAWDUST DEFLECTOR		1
17	F05026-4	WASHER, M8 FLAT		2
18	F05011-45	WASHER, M8 SPLIT LOCK		2
19	F05021-10	SCREW, M8-1.25 X 16 SHC		2
20	108060	PLATE, SAWDUST DIVERTER		1

REF	PART #	DESCRIPTION	COMMENTS	QTY.
21	F05020-55	SCREW, M5-.8X12MM BHCS		2
22	F81052-1	WASHER, 5.3 FE/ZN5		2
23	011416	WELDMENT, COVER LEFT		1
24	110992	WELDMENT, LX150 CENTER COVER		1

SECTION 5 CONTROL & BATTERY BOXES

5.1 Control Box Assembly

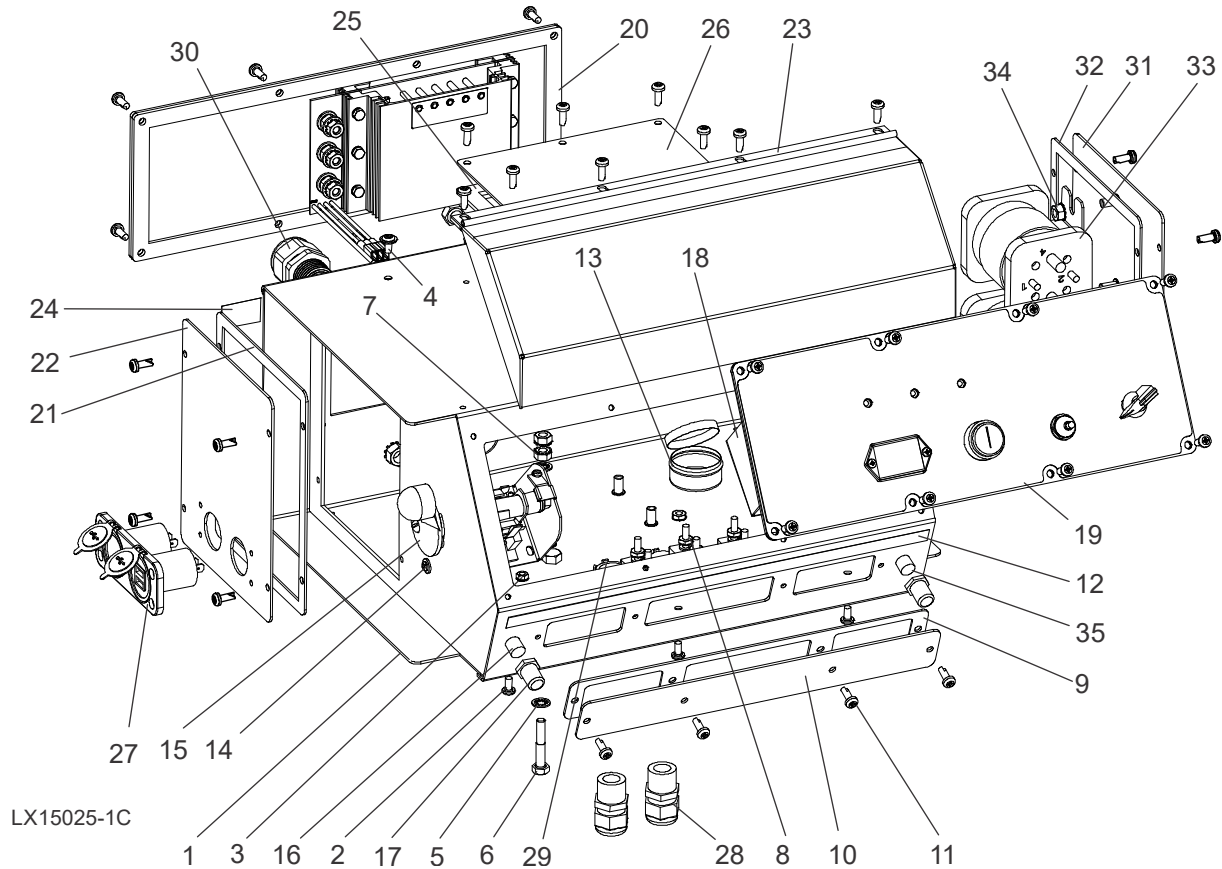

REF	PART #	DESCRIPTION	COMMENTS	QTY.
	073561	OPERATOR ASSEMBLY, LX150D24		1
	073588	OPERATOR ASSEMBLY, LX150G25		1
1	011271	Box Weldment, Control		1
2	F05004-3	Bolt, #10-24x3/8 CrSI PH		3
3	F05010-14	Nut, #10-24 Keps		7
4	F05004-148	Bolt, #10-24x3/8 CrSI Washer Pan Head		4
5	F05011-69	Washer, 1/4 Int Star Heavy Duty		2
6	F05005-31	Bolt, 1/4-20x1 1/2 Hex Head FT		1
7	F05010-9	Nut, 1/4-20 Keps		2
8	114030	Breaker Assy, LX150/LX250 Control ((See Section 5.4))		1
9	015266	Gasket, Circuit Breaker Panel		1
10	015376	Panel, Circuit Breaker		1
11	F05015-17	Bolt, #10-24x1/2 Ph Pan Hd, Type 23		40
12	069349	Decal, Circuit Breaker ID (2010 Std)		1
13	A20463	Grease, Drum Switch		1

REF	PART #	DESCRIPTION	COMMENTS	QTY.
14	F05011-41	Washer, #8 SAE Flat Zinc		6
15	052152	Switch Assembly Fwd/Rev Drum Std 2005 <i>((See Section 5.3))</i>		1
16	051981	Breaker, 40A Manual Reset Panel Mount		1
17	021253	Boot, Circuit Breaker		2
18	069350	Switch Assembly, '10 Std Up/Dn Drum <i>((See Section 5.3))</i>		1
19	024210	Panel Assembly, Front 97 (LX150D24)		1
	073673	Panel Assembly, LX150 Front (LX150G25) <i>((See Section 5.5))</i>		1
20	073578	Panel Assembly, Consolidated P/F CTRL 97+		1
21	015274	Gasket, Side Panel		2
22	011273	Plate, Control Box Side		1
23	015304	Cover Weldment		1
24	024366	Decal, Circuit Breaker ID (Auto Clutch)		1
25	065376	Gasket, Control Box Cover		1
26	065375	Plate, Control Box Cover		1
27	011274	USB Socket, Accessory		1
28	051299	Connector, 1/2" NPT .17-.47		2
29	E20461	Nut, 1/2 NPT Connector Lock		2
30	053479	Connector, 3/4" NPT .450-.709		3
	015425	Panel Assembly, Solenoid Up/Down 97		1
31	015307	Panel Weldment, Side		1
32	015274	Gasket, Side Panel Control 97		1
33	016370	Solenoid, 200A 12V DPST		2
34	F05010-9	Nut, 1/4-20 Keps		3
35	021256	Breaker, 50A Manual Reset Panel Mount		1

5.2 Control Box Mount & Up/Down Limit Switches

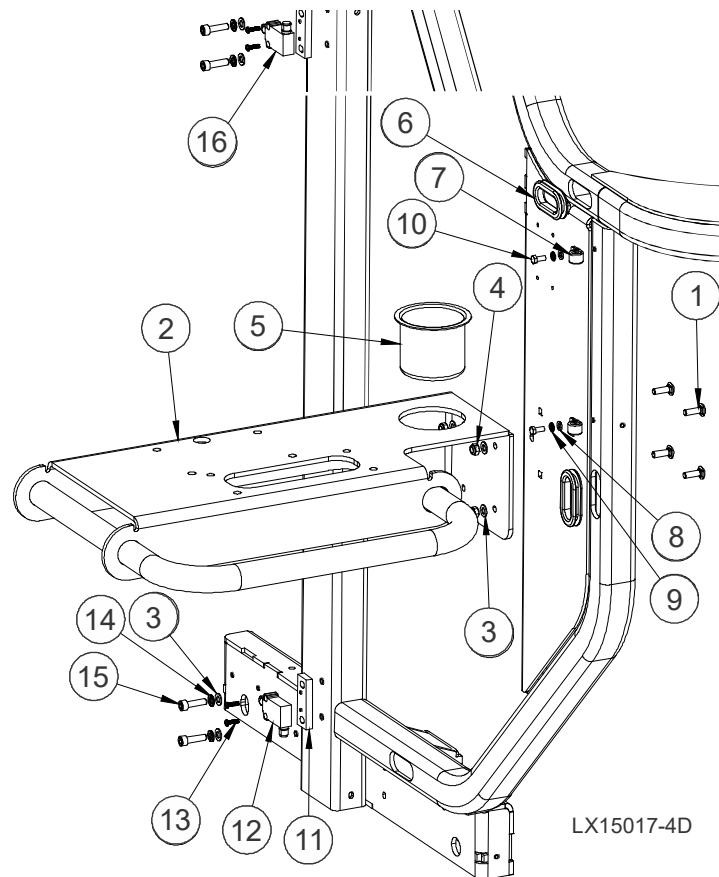

REF	PART #	DESCRIPTION	COMMENTS	QTY.
1	F05021-17	BOLT, M8-1.25X25 CARRIAGE CLASS 8.8		4
2	011065	WELDMENT, LX150 CONTROL MOUNT		1
3	F05026-4	WASHER, M8 FLAT		8
4	F05010-132	NUT, M8-1.25 HEX NYLOCK		4
5	011382	CUP HOLDER		1
6	011269	GROMMET, 1-3/4" ID X 2" HOLE RUBBER		5
7	011295	CLAMP, 1/2 IDX9/32 MOUNTING HOLE COATED		2
8	F05026-1	WASHER, M6 FLAT CLASS 4		2
9	F05026-2	WASHER, M6 SPLIT LOCK		2
10	F05020-7	BOLT, M6-1 X 14 CLASS 8 HEX HEAD		2
11	011375	BRACKET, LIMIT SWITCH MOUNTING		2
12	114013	SWITCH, LIMIT METAL ROLLER STRAIGHT CONN		1
13	F05020-26	SCREW, M4-.7X15 PAN HEAD PHILLIPS		4
14	F05004-47	BOLT, M8-1.25X16 HEX HEAD ZINC		4
15	F05021-1	SCREW, M8-1.25 X 30 SHC		4
16	011376	SWITCH, 90° LIMIT		1

5.3 Drum Switches

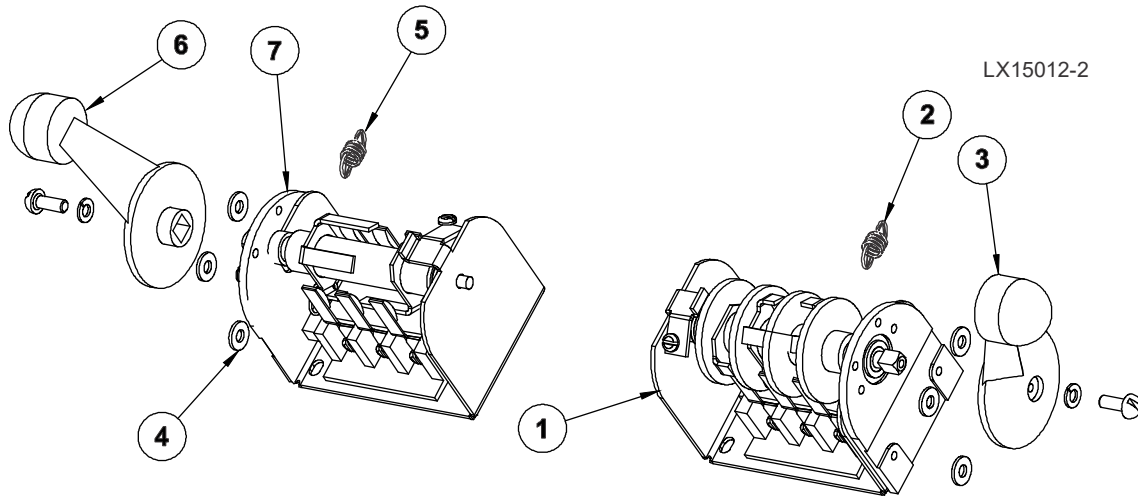

REF	PART #	DESCRIPTION	COMMENTS	QTY.
	E20440	SWITCH ASSEMBLY, UP/DOWN DRUM		1
1	E20440-B	Switch, S12 Bulk Drum	Available in assemblies only.	1
2	P12570	Spring, Drum Switch		1
3	P12500	Handle, Drum Switch Replacement		1
	E20439	SWITCH ASSEMBLY, POWER FEED DRUM		1
4	E20439-B	Switch, S11 Bulk Drum	Available in assemblies only.	1
5	P12570	Spring, Drum Switch		1
6	P12500	Handle, Drum Switch Replacement		1
7	F05011-41	WASHER, #8 SAE FLAT		6

5.4 Circuit Breakers

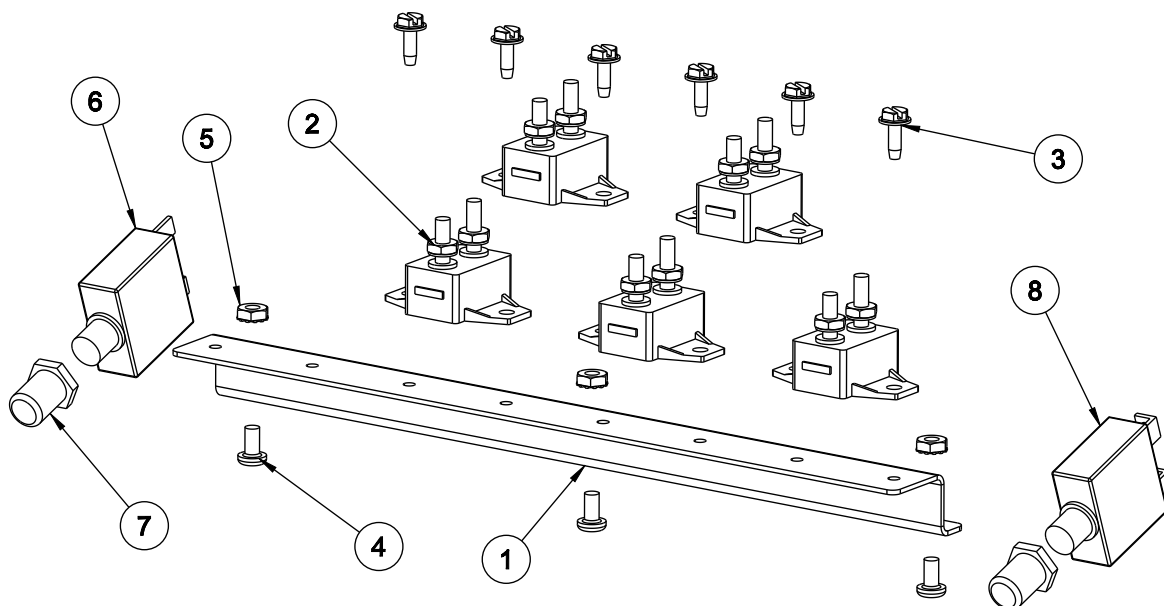

REF	PART #	DESCRIPTION	COMMENTS	QTY.
	114030	BREAKER ASSY, LX150/LX250 CONTROL		1
1	052826	Rail, Circuit Breaker Self Tap		1
2	E20430	Breaker, 15A Manual Reset		5
3	F05015-7	Bolt, #10-24x1/2 Self Tap		6
4	F05004-3	BOLT, #10-24X3/8 CRSL PH		3
5	F05010-14	NUT, #10-24 KEPS		3
6	051981	BREAKER, 40A MANUAL RESET PANEL MOUNT		1
7	021253	BOOT, CIRCUIT BREAKER		2
8	021256	BREAKER, 50A MANUAL RESET PANEL MOUNT		1

5.5 Front Panel Assembly & Harnesses

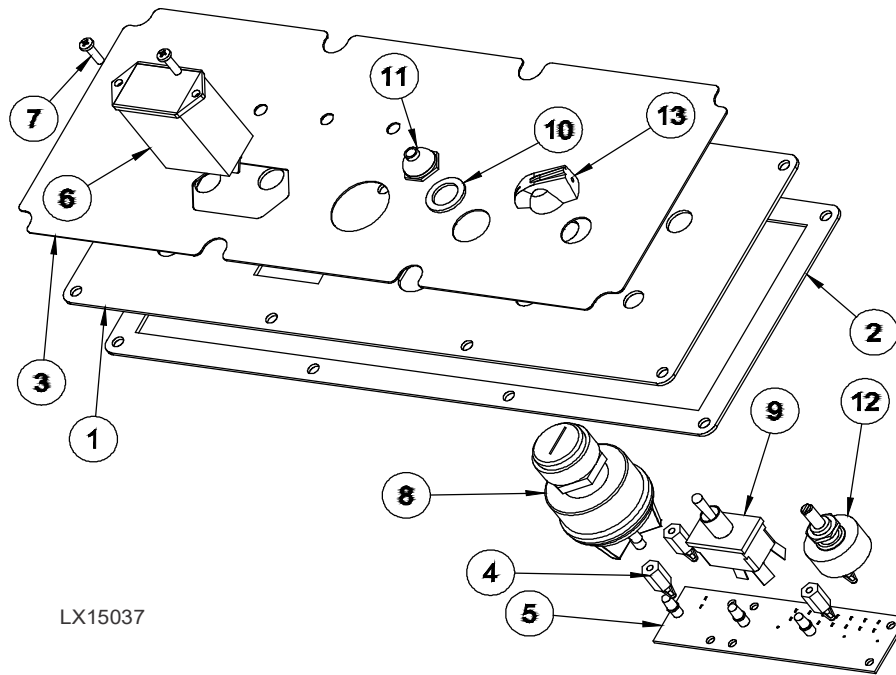

LX15037

REF	PART #	DESCRIPTION	COMMENTS	QTY.
	024210	Panel Assembly, Front 97 (D24)		
	073673	Panel Assembly, Front (G25)		1
1	015302	Panel Weldment, Face		1
2	015270	Gasket, Face Panel		1
3	015271	Decal, Gas/Elec Sawmill Control Panel		1
4	023147	Standoff, PCB 1/2 #6 Female Threading		4
5	015416	PCB Assembly, LED Diesel Sawmill 1997		1
6	015401	Meter, Hour Rectangle Mount		1
7	F05015-28	Screw, #6-32X1/2 Phil Pan HD T23, ZN		2
8	P04350	Switch, Key		1
9	024200	Switch, Toggle 21A DPDT Rev Mom Spade		1
10	P05251-1	Washer, 1/2x3/4x1/16 Nylon		1
11	P02575	Boot, Toggle Switch		1
12	024450-1	Pot Assembly, Feed Rate Control Sawmill		1
13	P06257	Knob, Speed Control		1
		LX150D24 Harnesses		
	073560	Harness Assy, LX150D24 Upper		1
	073562	Harness Assy, LX150 Feed		1
	073563	Harness Assy, LX150 Up/Down		1
		LX150G25 Harnesses		
	073587	Harness Assy, LX150G25 Upper		
	073562	Harness Assy, LX150 Feed		
	073563	Harness Assy, LX150 Up/Down		

5.6 Fuse Box

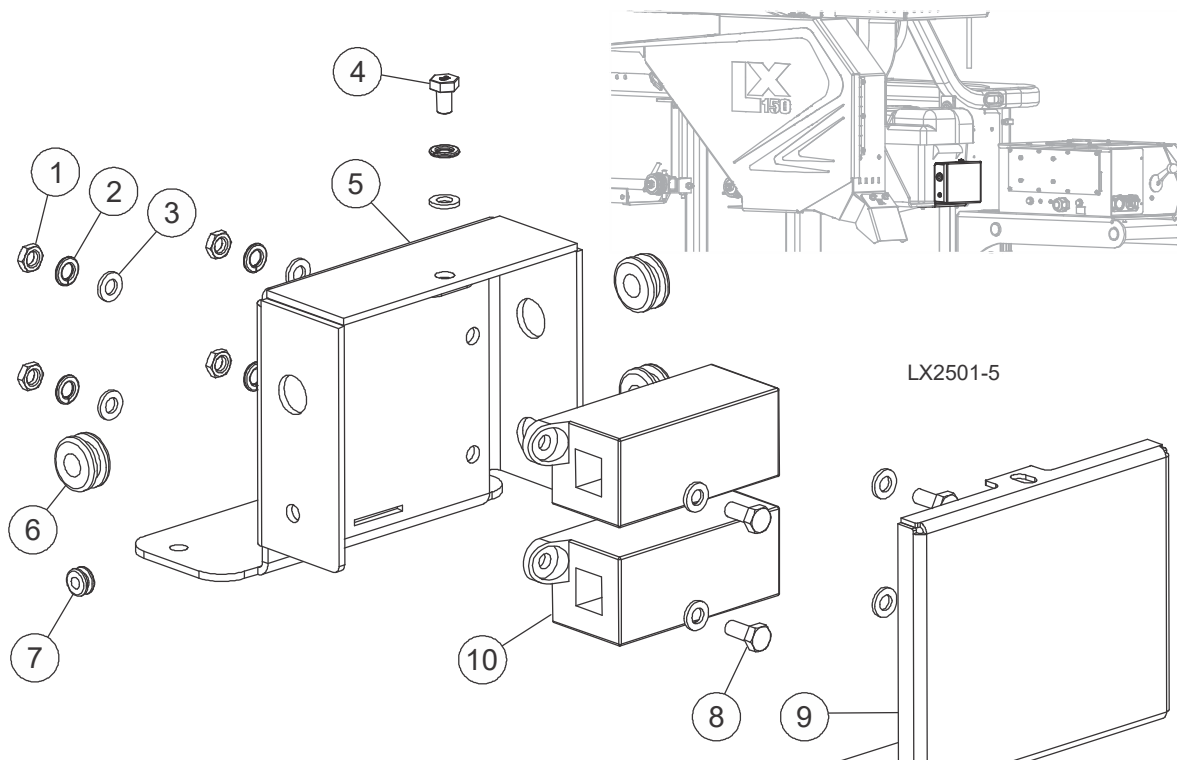

REF	PART #	DESCRIPTION	COMMENTS	QTY.
	128208	Assy, LX Fuse Block		
1	F05010-226	Nut, M6 x 1 Hex Jam		4
2	F05026-2	Washer, M6 Split Lock		5
3	F05026-1	Washer, M6 Flat Class 4		9
4	F05020-59	Bolt, M6-1x10mm HH FT 8.8 Zinc		1
5	128207	Weldment, LX Fuse Block		1
6	025248	Grommet, Rubber 3/8 Dia		3
7	042825	Grommet, 9/32Holex3/16IDx7/16OD		1
8	F05020-7	Bolt, M6-1 x 14 Class 8 HH		4
9	128206	Cover, LX Fuse Block		1
10	052371	Fuseholder, Mega Fuse	Quantity of 1 used on electric mills.	2
	052370-150	Fuse, 150A Mega	Not used on the electric mills.	1
	052370-060	Fuse, 60A Mega		1

5.7 Battery Box Assembly

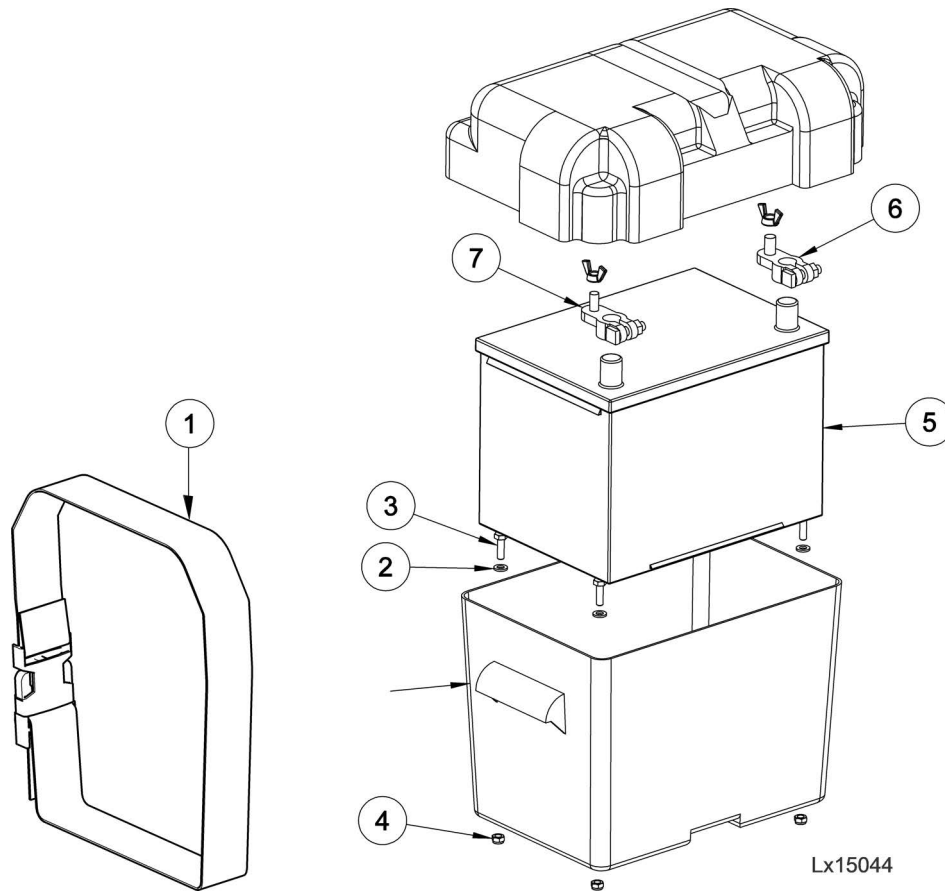

REF	PART #	DESCRIPTION	COMMENTS	QTY.
	110400	Assembly, LX150/LX250 Battery Box		1
1	016413	Box, Battery, Modified		1
2	F05026-1	Washer, M6 Flat Class 4		4
3	F05020-6	Bolt, M6-1 x 20 Class 8 HH		4
4	F05010-200	Nut, M6-1.0 Nylon Lock		4
5	079462	Battery, 580 CCA Deka		1
6	033358	Clamp, Pos. Battery		1
7	033359	Clamp, Neg. Battery		1
		For mills built prior to 12/16/2019:		
	073683	Fuse, 60A ZCase	Changed and removed fuses from inside the battery box to the fuse block assembly next to the battery box as of 12/16/2019.	1
	073684	Fuse, 150A ZCase ¹		1
	073685	Fuse Holder, Single ZCase ¹		2

SECTION 6 UP/DOWN SYSTEM

6.1 Mast Pad & Hardware

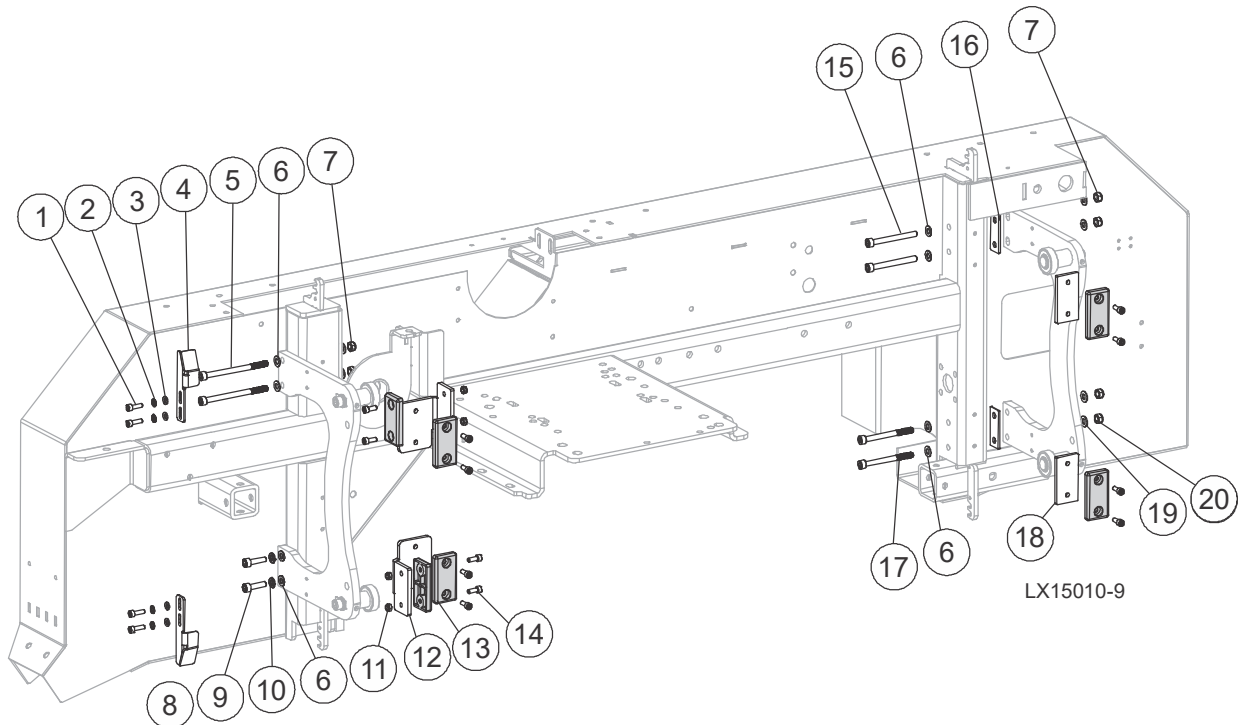

REF	PART #	DESCRIPTION	COMMENTS	QTY.
1	F05020-15	SCREW, M6-1 X 20 SHC		4
2	F05026-2	WASHER, M6 SPLIT LOCK		4
3	F05026-1	WASHER, M6 FLAT CLASS 4		4
4	110800	BRACKET, UPPER LIMIT SWITCH		1
5	F05021-39	SCREW, M8-1.25X110MM SHCS		3
6	F05026-4	WASHER, M8 FLAT		10
7	F05010-132	NUT, M8-1.25 HEX NYLOCK		4
8	011323	BRACKET, LOWER LIMIT SWITCH		1
9	F05020-15	SCREW, M6-1 X 20 SHC		2
10	F05011-45	WASHER, 8MM SPLIT LOCK, ZN		2
11	F05010-200	NUT, M6-1.0 NYLON LOCK		4
12	110806	BRACKET, SLIDE PAD MOUNT		2
13	P13576	PAD, CATAPILLAR TRACK		6
14	F05004-206	BOLT, M6-1.0X16MM SHCS		12
15	F05021-27	SCREW, M8-1.25 X 80 SHC FT		2
16	110599	SHIM PLATE, MAST ROLLERS		2
17	F05021-37	SCREW, M8-1.25X85MM SHCS		2
18	110807	SHIM, SLIDE PAD, 1/4		2
19	F81054-1	WASHER, 8.4 FLAT, ZINC		2
20	F81032-2	NUT,M8-8-B,HEX,NYLON LOCK ZINC		2

6.2 Blade Height Scales & Mast Angles

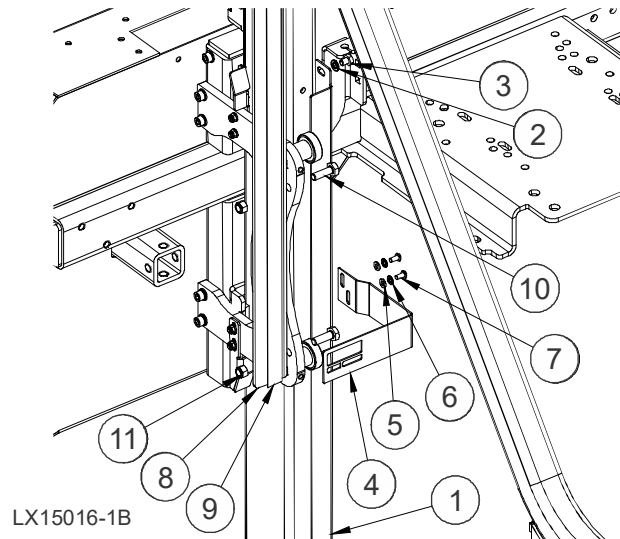

REF	PART #	DESCRIPTION	COMMENTS	QTY.
1	033827	ANGLE, MAST TUBE STAINLESS		2
2	F05011-45	WASHER, M8 SPLIT LOCK		1
3	F05021-51	BOLT, M8-1.25X10MM HHC		6
4	110896	PLATE, SIGHT GAUGE	Sight Guide Plate changed from 108025 to 110896 as of revision A2.00 (5/2019).	1
5	F05026-1	WASHER, M6 FLAT CLASS 4		2
6	F05026-2	WASHER, M6 SPLIT LOCK		2
7	F05004-275	SCREW, M6-1.0 X 12MM BHCS BLACK OXIDE		2
8	108023	SUPPORT, DEPTH GAUGE		1
9	S11773	DECAL, MOVABLE INCH SCALE		1
10	F05022-3	BOLT, M10-1.5X30 CLASS 8 HH		2
11	F05004-270	NUT, M10-1.50 HEX NYL LOCK		2

6.3 Head Mounting Assembly

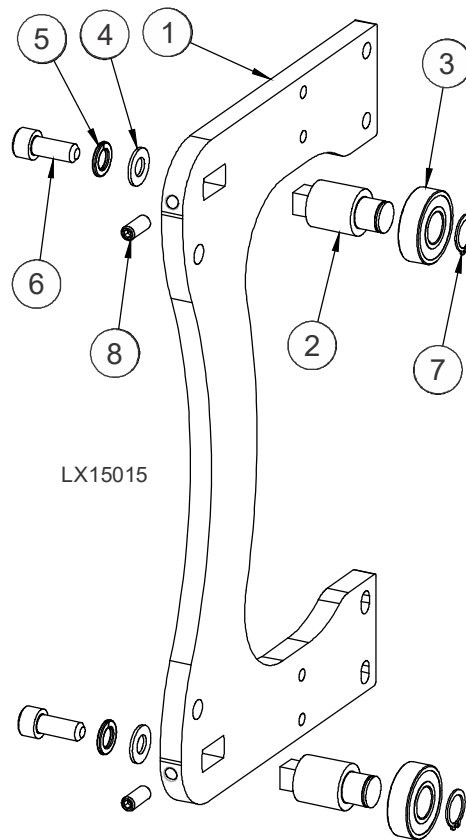

REF	PART #	DESCRIPTION	COMMENTS	QTY.
	110808	ASSEMBLY, LX150 HEAD MOUNTING		1
1	110799	Guide, LX150 Mast		1
2	011137	Shaft, Head Hold Down		2
3	P06030-2	Bearing, 6203-2NSL 17mm SRI-2 ABEC-1		2
4	F05011-134	Washer, M10 Flat		2
5	F05011-88	Washer, 10MM Split Lock		2
6	F05022-12	Bolt, M10-1.5 x 25 SHC		2
7	F04254-16	Ring, 17mm OR		2
8	F05021-7	Screw, M8-1.25 x20 SHFP Set		2

6.4 Up/Down Assembly

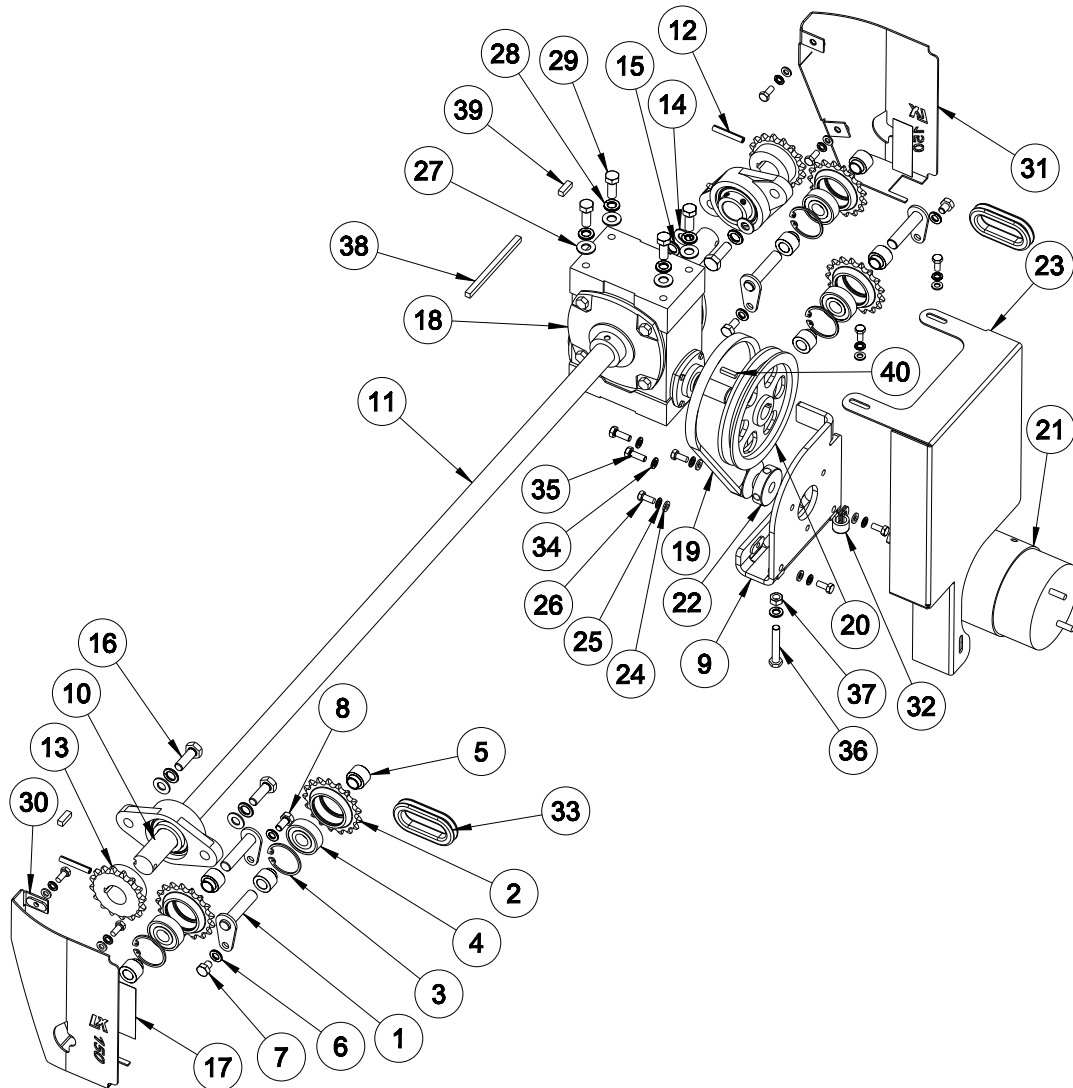

REF	PART #	DESCRIPTION	COMMENTS	QTY.
1	011213	WELDMENT, 1/2X2-1/8 IDLER PIN		4
	016366	SPROCKET ASSEMBLY, #40/#41 CHAIN 17T		4
2	016365	Sprocket, #40/41 Chain 17 Tooth		1
3	F04254-4	Ring, 1.575 Id N5100-156 Snap		1
4	BEARING016366	Bearing, Japanese 6203-2RS 5/8 C3/ALV3		1
5	011176	BUSHING, IDLER SPACING		8
6	F05011-45	WASHER, 8MM SPLIT LOCK, ZN		5
7	F05021-51	BOLT, M8-1.25X20MM HEX HEADC		2
8	F05004-47	BOLT, M8-1.25X16 HEX HEAD ZINC		2
9	011300	WELDMENT, DC UP/DN MOTOR ADJUST		1
10	038124	BEARING, 1 FLANGED, VF2S 216		2
11	011211	SHAFT, LX150 UP/DN		1
12	F05012-125	PIN, 1/4 X 1-1/2 ROLL		2

REF	PART #	DESCRIPTION	COMMENTS	QTY.
13	007311	SPROCKET, 40B16X1		2
14	F05011-134	WASHER, M10 FLAT		4
15	F05011-88	WASHER, 10MM SPLIT LOCK		4
16	F05022-3	BOLT, M10-1.5X30 HEX HEAD CLASS 8		4
17	011284	DECAL, 3X1 ORANGE VINYL		2
18	011317	GEARBOX, 60:1 THRU SHAFT		1
19	038459	BELT, 4L245		1
20	066781	SHEAVE, 5.45 OD 3/4 BORE 4L		1
21	006747	MOTOR, 1/2HP 12VDC, CURRENT APPLICATIONS		1
22	S09579	SHEAVE, 1 3/4 FEED MOTOR		1
23	011392	GUARD, LX150 UP/DN		1
24	F05026-1	WASHER, M6 FLAT CLASS 4		10
25	F05026-2	WASHER, M6 SPLIT LOCK		10
26	F05020-7	BOLT, M6-1 X 14 CLASS 8 HEX HEAD		10
27	F05011-3	WASHER, 3/8 FLAT SAE		4
28	F05011-4	WASHER, 3/8 SPLIT LOCK		4
29	F05007-87	BOLT, 3/8-16X1 GR5 HEX HEAD		4
30	011135	WELDMENT, LX150 LEFT SPROCKET GUARD		1
31	011129	WELDMENT, LX150 RIGHT SPROCKET GUARD		1
32	011295	CLAMP, 1/2 IDX9/32 MOUNTING HOLE COATED		1
33	011269	GROMMET, 1-3/4" ID X 2" HOLE RUBBER		2
34	F05011-14	WASHER, 1/4 SPLIT LOCK		3
35	F05005-123	BOLT, 1/4-20X3/4 HEX HEAD GR5	Second F05005-123 and F81002-19 bolts added after 11/21/2019.	3
36	F81002-19	BOLT, M8X50 8.8 HEX HEAD FT ZINC		2
37	F05010-162	NUT, M8-1.25 FREE ZINC		2
38	S22440	KEY, 1/4X4 1/4		1
39	S03167	KEY, 1/4 SQX3/4 LONG		2
40	S03060	KEY, 3/16 SQX3/4 LONG		1
	110980	CHAIN, #40X121-1/2 (243 PITCHES)		2

SECTION 7 FEED SYSTEM & TRACK ROLLERS

7.1 Track Rollers and Wipers (Drive Side)

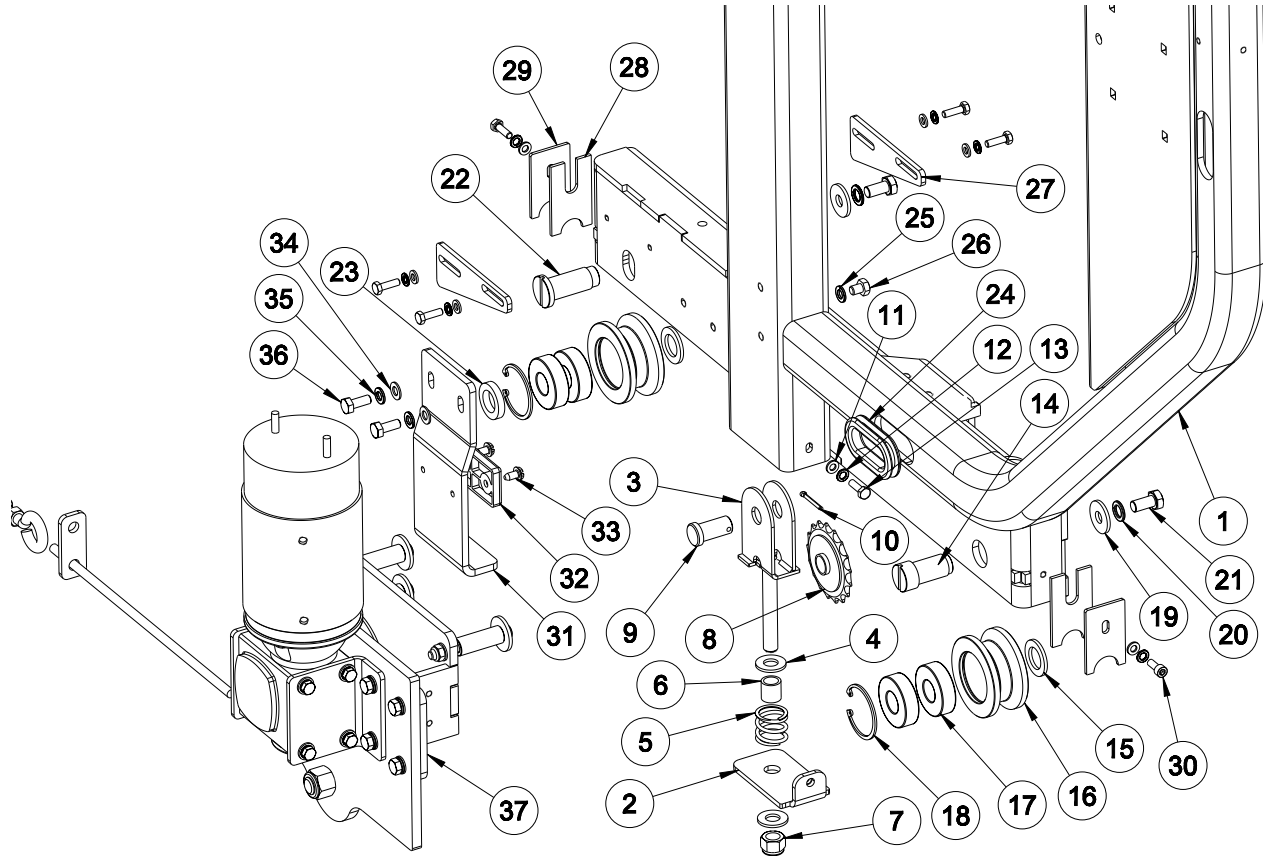

REF	PART #	DESCRIPTION	COMMENTS	QTY.
1	011025	UPRIGHT WELDMENT, LX150		1
2	011372	WELDMENT, TENSION SPROCKET MOUNTING		1
	011370	ASSEMBLY, LX150 UP/DN CHAIN TENSION		1
3	011369	Weldment, LX150 Up/Dn Chain Tension		1
4	F05011-2	Washer, 1/2 SAE Flat		2
5	016516	Spring, 1ODx1Longx.125Wire Comp		1
6	016515	Spacer, Up/Dn Chain Tensioner		1
7	F05010-8	Nut, 1/2-13 Nyl Hex Lock		1
8	P04333	Sprocket, #40 Idler 17T 5/8ID		1
9	F05012-159	Pin, 5/8x1 Usable Lg. Clevis		1
10	F05012-1	Pin, 1/8x1 Cotter		1
11	F05026-1	WASHER, M6 FLAT CLASS 4		7
12	F05026-2	WASHER, M6 SPLIT LOCK		7
13	F05020-6	BOLT, M6-1X20 HEX HEAD CLASS 8		6
14	515018	SHAFT, LX150 ROLLER		1
15	011351	WASHER, LX150 THIN ROLLER		2
	515015_US	ROLLER ASSEMBLY, LX150		2
16	514889_US	Roller, LX150		1

7

Bed Frame Assembly*Track Rollers and Wipers (Drive Side)*

REF	PART #	DESCRIPTION	COMMENTS	QTY.
17	088447	Bearing, 6204 2RRS-CX Rolling		2
18	089653	Ring, Retaining W 47, Pn-81/m-85111		1
19	088787	SPACER, LX150 HEIGHT ADJUST		2
20	F05011-88	WASHER, 10MM SPLIT LOCK		2
21	F05004-207	BOLT, M10-1.50X20MM HEX HEAD FT 8.8		2
22	515101	SHAFT, LX100/150 ADJUSTMENT		1
23	011352	WASHER, LX150 THICK ROLLER		1
24	011269	GROMMET, 1-3/4" ID X 2" HOLE RUBBER		1
25	F05011-45	WASHER, 8MM SPLIT LOCK, ZN		1
26	F05021-51	BOLT, M8-1.25X20MM HEX HEADC		1
27	516508-1	PLATE, LX150 HEIGHT ADJUST		2
28	517609	WIPER		2
29	517610-1	PLATE, LX150 RAIL WIPER		2
30	F05020-6	BOLT, M6-1.0X16MM SHCS		1
	011120	ASSEMBLY, LX150 MAST SAFETY		1
31	011119	Plate, LX150 Mast Safety		1
32	P13576	Pad, Catapillar Track		1
33	F05015-1	Bolt, 1/4-20x1/2 SI Hex Head		2
34	F05026-4	Washer, M8 Flat		2
35	F05011-45	Washer, 8mm Split Lock, Zn		2
36	F05021-2	Bolt, M8-1.25x20 Class 8 Hex Head		2
37	011381	ASSEMBLY, LX150 ROPE POWER FEED	<i>(See Section 7.3) for parts</i>	1

7.2 Track Roller And Wipers (Idle Side)

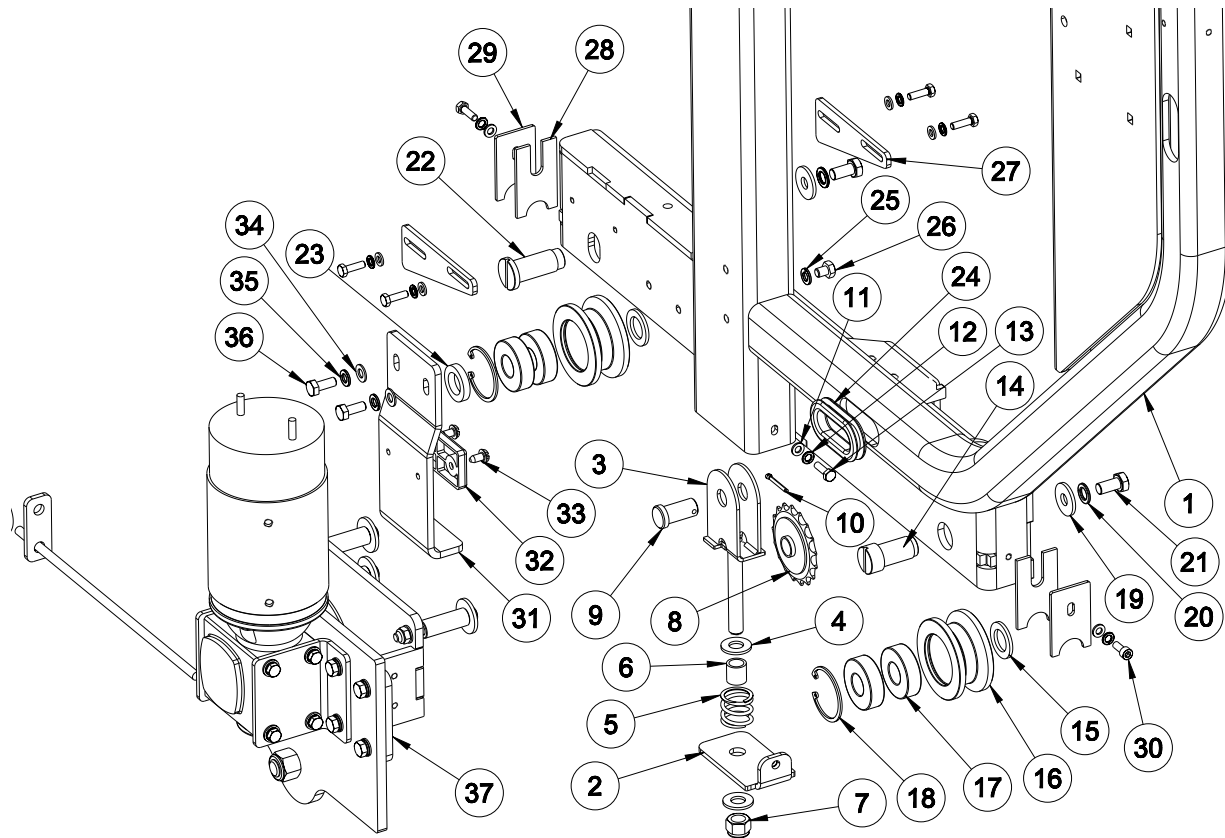

REF	PART #	DESCRIPTION	COMMENTS	QTY.
1	011372	WELDMENT, TENSION SPROCKET MOUNTING		1
	011370	ASSEMBLY, #40 CHAIN TENSION		1
2	011369	Weldment, #40 Chain Tension		1
3	F05011-2	Washer, 1/2 SAE Flat		2
4	016516	Spring, 10Dx1Longx.125Wire Comp		1
5	016515	Spacer, Up/Dn Chain Tensioner		1
6	F05010-8	Nut, 1/2-13 Nyl Hex Lock		1
7	P04333	Sprocket, #40 Idler 17T 5/8ID		1
8	F05012-159	Pin, 5/8x1 Usable Lg. Clevis		1
9	F05012-1	Pin, 1/8x1 Cotter		1
10	F05026-1	WASHER, M6 FLAT CLASS 4		7
11	F05026-2	WASHER, M6 SPLIT LOCK		7
12	F05020-6	BOLT, M6-1X20 HEX HEAD CLASS 8		6
13	515018	SHAFT, LX150 ROLLER		1
14	011351	WASHER, LX150 THIN ROLLER		2
	515015_US	ROLLER ASSEMBLY, LX150		2
15	514889_US	Roller, LX150		1
16	088447	Bearing, 6204 2RRS-CX Rolling		2
17	089653	Ring, Retaining W 47, Pn-81/m-85111		1
18	088787	SPACER, LX150 HEIGHT ADJUST		2

REF	PART #	DESCRIPTION	COMMENTS	QTY.
19	F05011-88	WASHER, 10MM SPLIT LOCK		2
20	F05004-207	BOLT, M10-1.50X20MM HEX HEAD FT 8.8		2
21	515101	SHAFT, LX100/150 ADJUSTMENT		1
22	011352	WASHER, LX150 THICK ROLLER		1
23	516508-1	PLATE, LX150 HEIGHT ADJUST		2
24	517609	WIPER		2
25	517610-1	PLATE, RAIL WIPER		2
26	F05020-6	BOLT, M6-1.0X16MM SHCS		1
	011120	ASSEMBLY, MAST SAFTEY		2
27	011119	Plate, Mast Saftey		1
28	P13576	Pad, Catapillar Track		1
29	F05015-1	Bolt, 1/4-20x1/2 SI Hex Head		2
30	F05026-4	WASHER, M8 FLAT		2
31	F05011-45	WASHER, M8 SPLIT LOCK		2
32	F05021-2	BOLT, M8-1.25X20 CLASS 8 HEX HEAD		2

7.3 Power Feed Assembly

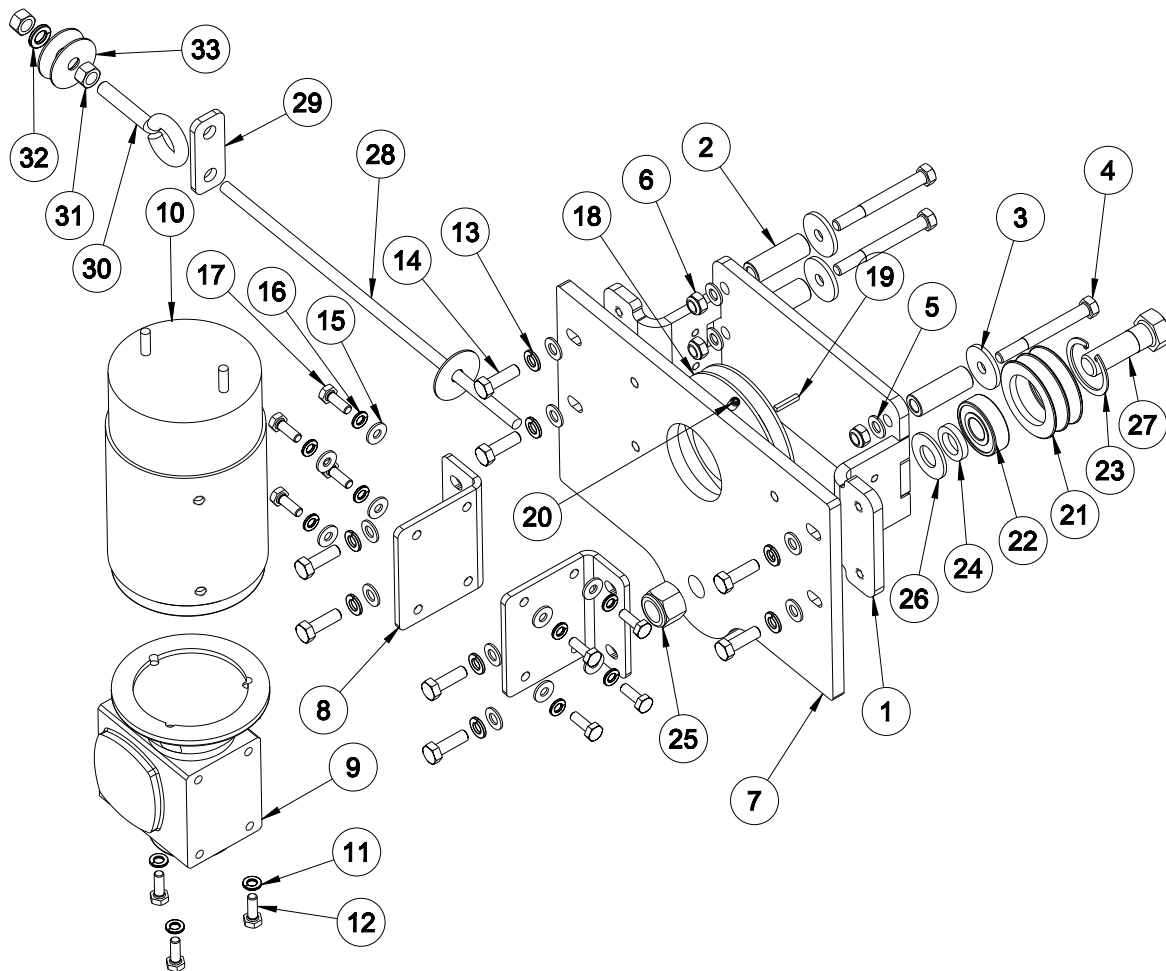

REF	PART #	DESCRIPTION	COMMENTS	QTY.
	011381	ASSEMBLY, LX150 ROPE POWER FEED		1
1	517886-1	Weldment, Rope Power Feed Mounting		1
2	517914-1	Spacer, Power Feed Mounting		3
3	F05011-105	Washer, 5/16 x 1-1/4 x 1/8 Zn		3
4	F05021-34	Bolt, M8-1.25x75mm Hex Head Class8.8		3
5	F05026-4	Washer, M8 Flat		11
6	F05010-132	Nut, M8-1.25 Hex Nylock		3
7	011378	Plate, LX150 Power Feed Mnt		1
8	011379	Plate, LX150 Gearbox Mounting		2
	011151	Assembly, LX150 PF Motor/Gearbox		1
9	011155	Gearbox, 10:1 x 1/2hp		1
10	006747	Motor, 1/2hp 12VDC, Current Applications		1
11	F05011-14	Washer, 1/4 Split Lock		3
12	F05005-123	Bolt, 1/4-20x3/4 Hex Head Gr5		3
13	F05011-45	Washer, 8mm Split Lock, Zn		8
14	F05004-40	Bolt, M8x1.25x25 Hex Head FT		8
15	F05011-11	Washer, 1/4 SAE Flat		8

REF	PART #	DESCRIPTION	COMMENTS	QTY.
16	F05011-14	Washer, 1/4 Split Lock		8
17	F05005-1	Bolt, 1/4-20x3/4 FT Hex HeadC		8
18	011353	Pulley, LX150 Rope Feed		1
19	036803	Key, 1/8x1/8x3/4	036803 replaced 060089 after 01/12/2021 per ECN 37770.	1
	060089	Key, 1/8 x 3/4 Machine		1
20	F05005-108	Screw, 1/4-20 X 3/8 Half Dog BO Set		2
	046979	Roller Assembly, Lower Feed		1
21	046838	Roller, 2 1/4 Double Groove		1
22	P06030-1	Bearing, 5/8x1.7548x.4724		1
23	F04254-8	Ring, 1.575 Internal Beveled Retaining		1
24	S12480	Tube, 41/64x1x3/16		1
25	F05010-34	Nut, 5/8-11 Nyl Lock		1
26	F05011-5	Washer, 5/8 SAE Flat		1
27	F05009-2	Bolt, 5/8-11x2 Hex Hd Gr2, Zn		1
28	018035	Rope, 5/16 Dia Solid Braided Poly 34Ft		1
29	049339	Plate, Rope Lock		1
30	F05007-30	Bolt, 3/8-16 X 2 Eye 5/8 Id		1
31	F05010-1	Nut, 3/8-16 Hex		2
32	F05011-4	Washer, 3/8 Split Lock		1
33	F05011-44	Washer, 3/8 Fender		3

7.4 Travel Lock Assembly

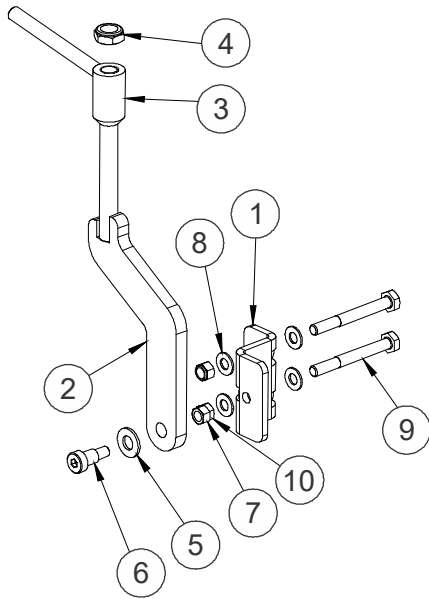

LX15036B

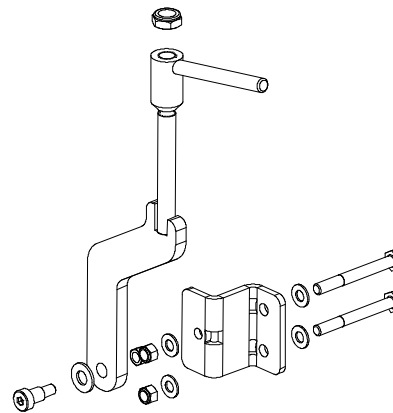

REF	PART #	DESCRIPTION	COMMENTS	QTY.
	110741	LOCK ASSEMBLY, TRAVEL		1
1	110778	Bracket, Travel Lock Mount		2
2	079600	Lock Weldment, Travel		2
3	079747	Nut Weldment, Travel Lock		2
4	F05010-101	Nut, 5/8-18 Nyl Jam		2
5	F05011-2	Washer, 1/2 SAE Flat		2
6	F05008-115	Bolt, 1/2x5/8 Shoulder 3/8-16 Thrd Unplated		2
7	F05010-25	Nut, 3/8-16 Swaged		2
8	F05011-134	Washer, M10 Flat		8
9	F05022-22	Bolt, M10-1.5x90 Hex Head Class 8		4
10	F05004-270	Nut, M10-1.50 Hex Nyl Lock		4

SECTION 8 BED FRAME ASSEMBLY

8.1 Bed Frame Assembly

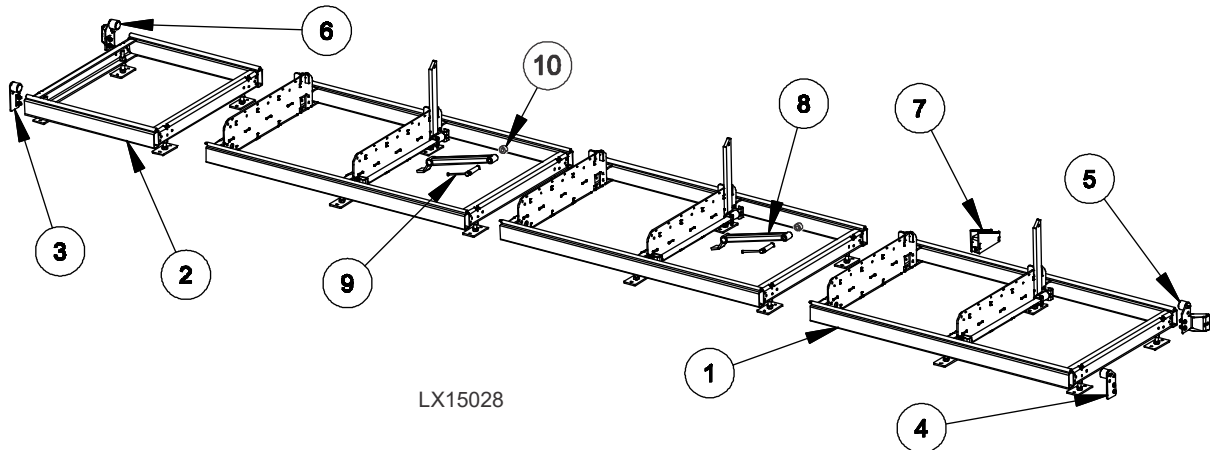

REF	PART #	DESCRIPTION	COMMENTS	QTY.
	516522-S3	BED ASSEMBLY, LX150		1
1	516521	Bed, Section	(See Section 8.2)	1
2	516524	Bed, Section Front	(See Section 8.3)	1
3	515062	Stop Assembly, Front Left Complete	(See Section 8.4)	1
4	515063	Stop Assembly, Rear Left Complete	(See Section 8.5)	1
5	517897	Stop Assembly, Rear Right Complete	(See Section 8.6)	1
6	517896	Stop Assembly, Front Right Complete	(See Section 8.7)	1
7	515413-1	Wedge, LX100		1
	130098	Assy, Metric Log Clamp		1
8	524191-1	Arm, LX150 Clamp		2
9	507563	Bolt, Clamp Complete		2
10	075295	Block, Clamp Point		2

8.2 Bed Section Assembly

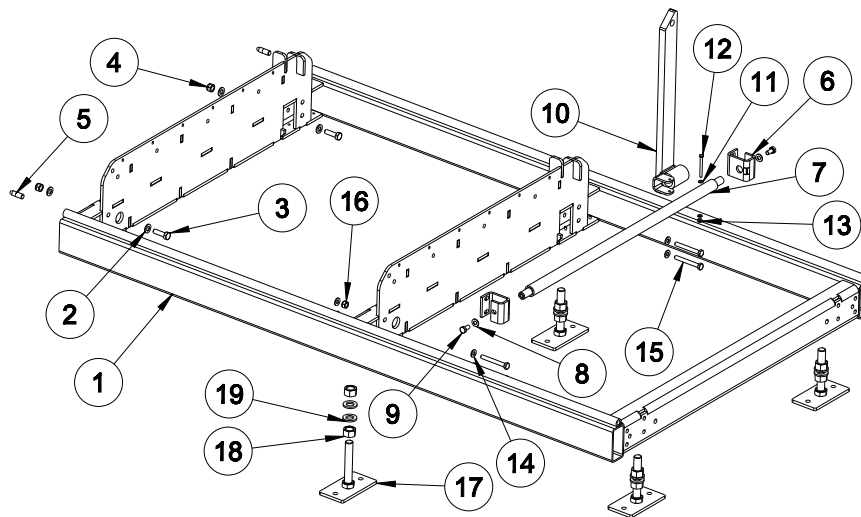

REF	PART #	DESCRIPTION	COMMENTS	QTY.
	516521	BED SECTION ASSEMBLY, LX150		1
1	516264-1	Weldment, Bed Section		1
2	F81056-1	Washer, M12 Flat Zinc		4
3	F81004-4	Bolt, M12x40-8.8-Fe/Zn5 PN-M/82105		2
4	F81034-2	Nut, M12-8 Fe/Zn5 PN-M/82175		2
5	090675	Stud, Special		2
	516519	Support Assembly, LX150 Side		1
6	500338-1	Bracket, Clamp Mount		2
7	516520-1	Rod, Clamp		1
8	F81055-1	Washer, Flat 10,5 Fe/Zn5 PN-78/M-82005		2
9	F81003-1	Bolt, M10x20-5.8-Fe/Zn5 PN-M/82105		2
	524190	Support, Side Complete		1
10	524189-1	Weldment, Side Support		1
11	F81053-1	Washer, M6 Flat Zinc		2
12	F81001-9	Bolt, M6x60-8.8-Fe/Zn5 PN-85/M-82105		1
13	F81031-2	Nut, M6-8-B-Fe/Zn5 PN-M/82175		1
14	F81055-1	Washer, Flat 10,5 Fe/Zn5 PN-78/M-82005		8
15	F81003-50	Bolt, M10x80 -8.8- Fe/Zn5 PN-M/82101		4
16	F81033-1	Nut, M10-8-B -Fe/Zn PN-M82175		4
	514997	Leg Assembly, LT15 Complete		4
17	514996-1	Leg, LT15		1
18	F81037-1	Nut, M20-8-Fe/Zn5 PN-86/M-82144		2
19	F81059-2	Washer, 21 Fe/Zn5 PN-M/82005		2

8.3 Bed Section Assembly, Front

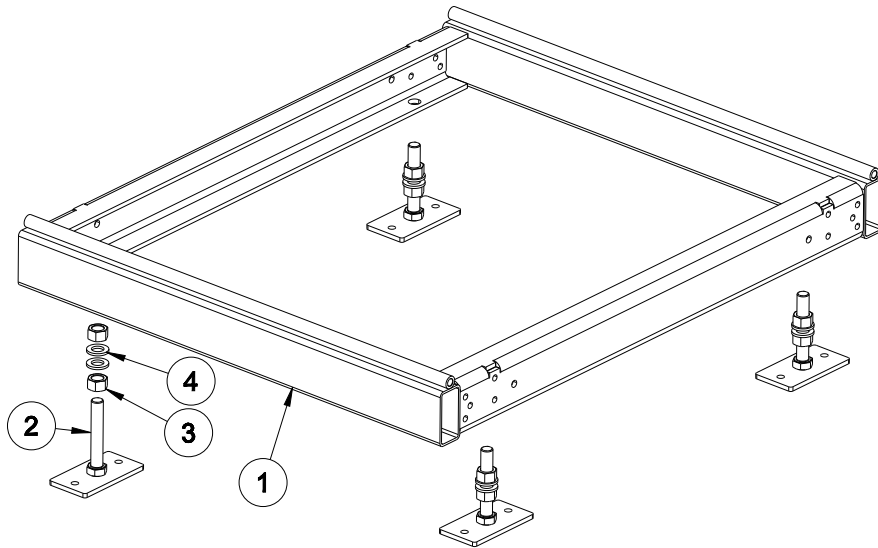

REF	PART #	DESCRIPTION	COMMENTS	QTY.
	516524	BED SECTION ASSEMBLY, LX150 FRONT		1
1	516254-1	Weldment, Bed Section		1
	514997	Leg Assembly, LT15 Complete		4
2	514996-1	Leg, LT15		1
3	F81037-1	Nut, M20-8-Fe/Zn5 PN-86/M-82144		2
4	F81059-2	Washer, 21 Fe/Zn5 PN-M/82005		2

8.4 Bed Stop Assembly, Front Left

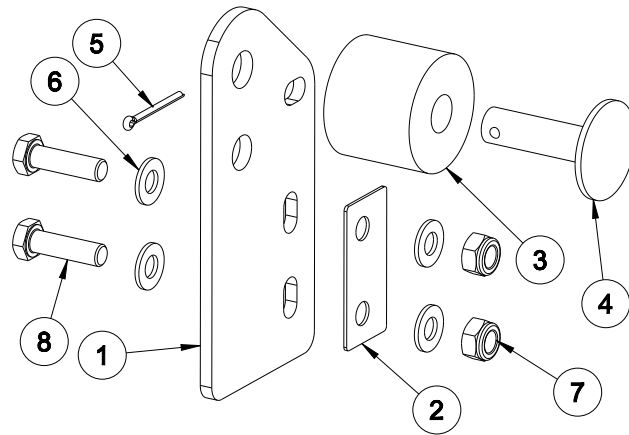

REF	PART #	DESCRIPTION	COMMENTS	QTY.
	515062	BED STOP ASSEMBLY, FRONT LEFT		1
1	516075-1	Plate, Bed Stop		1
2	515061-1	Plate, Bed Stop Shim		1
3	P12165	Bushing, Bed Stop		1
4	086182-1	Bolt, Bed Stop		1
5	F81043-2	Pin, Roll S-Zn 4x25 PN-M/82001		1
6	F81055-1	Washer, Flat 10,5 Fe/Zn5 PN-78/M-82005		4
7	F81033-1	Nut, M10-8-B -Fe/Zn PN-M82175		2
8	F81003-17	Bolt, M10x35-8.8 Fe/Zn5 PN-M/82105		2

8.5 Bed Stop Assembly, Rear Left

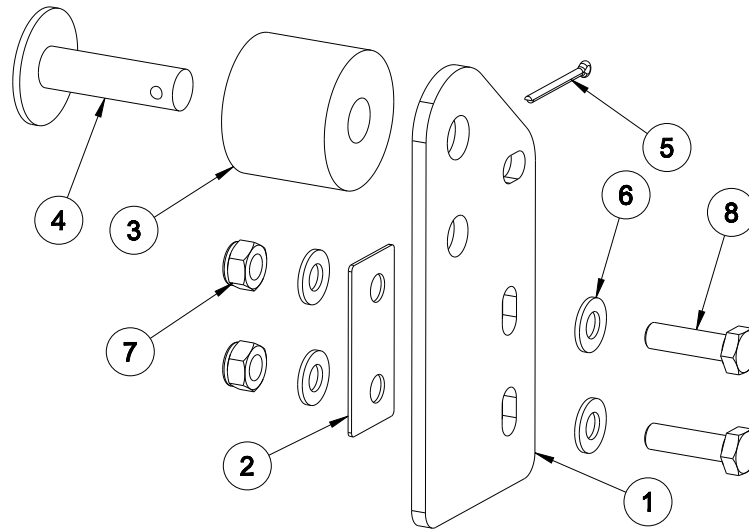

REF	PART #	DESCRIPTION	COMMENTS	QTY.
	515063	BED STOP ASSEMBLY, REAR LEFT		1
1	516075-1	Plate, Bed Stop		1
2	515061-1	Plate, Bed Stop Shim		1
3	P12165	Bushing, Bed Stop		1
4	086182-1	Bolt, Bed Stop		1
5	F81043-2	Pin, Roll S-Zn 4x25 PN-M/82001		1
6	F81055-1	Washer, Flat 10,5 Fe/Zn5 PN-78/M-82005		4
7	F81033-1	Nut, M10-8-B -Fe/Zn PN-M82175		2
8	F81003-17	Bolt, M10x35-8.8 Fe/Zn5 PN-M/82105		2

8.6 Bed Stop Assembly, Rear Right

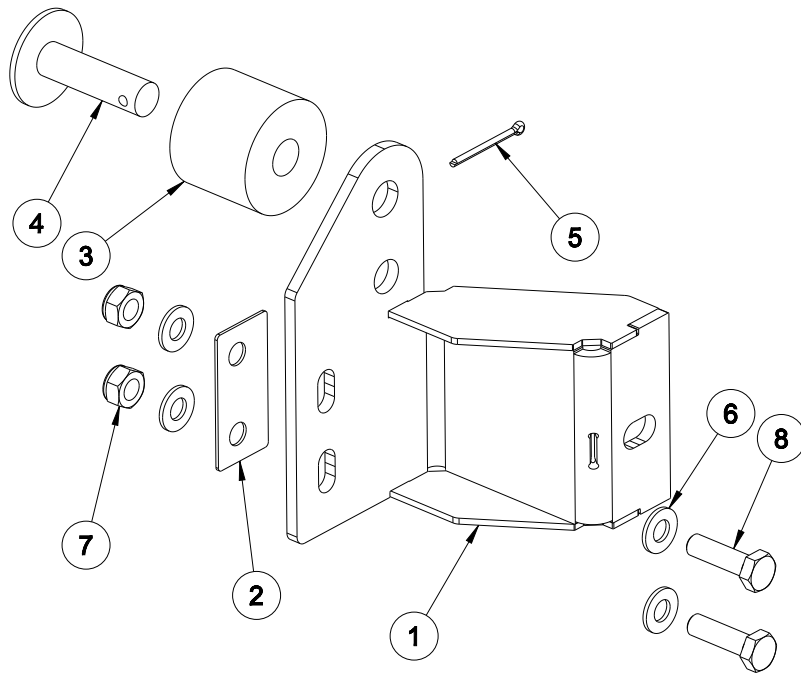

REF	PART #	DESCRIPTION	COMMENTS	QTY.
	517897	BED STOP ASSEMBLY, REAR RIGHT		1
1	517902-1	Plate, Bed Stop		1
2	515061-1	Plate, Bed Stop Shim		1
3	P12165	Bushing, Bed Stop		1
4	086182-1	Bolt, Bed Stop		1
5	F81043-2	Pin, Roll S-Zn 4x25 PN-M/82001		1
6	F81055-1	Washer, Flat 10,5 Fe/Zn5 PN-78/M-82005		4
7	F81033-1	Nut, M10-8-B -Fe/Zn PN-M82175		2
8	F81003-17	Bolt, M10x35-8.8 Fe/Zn5 PN-M/82105		2

8.7 Bed Stop Assembly, Front Right

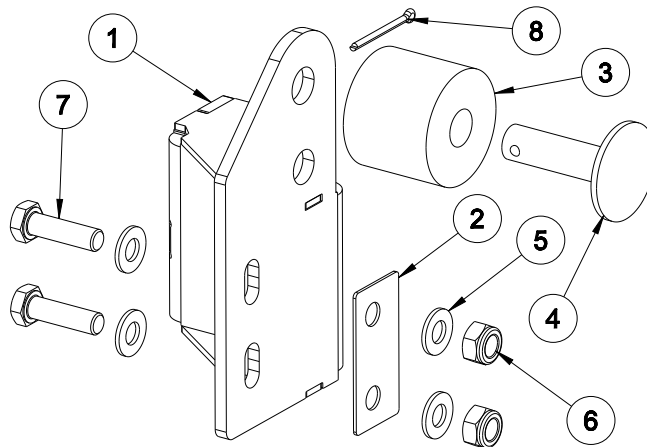

REF	PART #	DESCRIPTION	COMMENTS	QTY.
	517896	BED STOP ASSEMBLY, FRONT RIGHT		1
1	517901-1	Plate, Bed Stop		1
2	515061-1	Plate, Bed Stop Shim		1
3	P12165	Bushing, Bed Stop		1
4	086182-1	Bolt, Bed Stop		1
5	F81043-2	Pin, Roll S-Zn 4x25 PN-M/82001		1
6	F81055-1	Washer, Flat 10,5 Fe/Zn5 PN-78/M-82005		4
7	F81033-1	Nut, M10-8-B -Fe/Zn PN-M82175		2
8	F81003-17	Bolt, M10x35-8.8 Fe/Zn5 PN-M/82105		2

SECTION 9 MISCELLANEOUS

9.1 Replacement Manuals

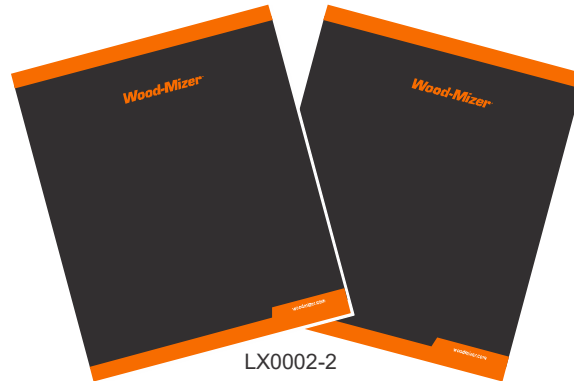

REF	DESCRIPTION	PART #	QTY.	
	Wood-Mizer Product Information			
1	ALL-PRODUCTS CATALOG	PS750	1	
	Basic Sawmill Manuals			
2	TRU-SHARP BLADE HANDBOOK	M600	1	
3	WOOD-MIZER GENERAL INFORMATION	M601	1	
4	LX150 OPERATOR'S MANUAL	M2272	1	
5	LX150 PARTS MANUAL	M2274	1	
	Power Option Manuals			
6	G25 ENGINE OPTION MANUAL	M2276	1	
	Miscellaneous Manuals			
7	SHINGLE/LAPSIDER MANUAL (OPTION)	M621	1	
8	RESAW ATTACHMENT MANUAL (OPTION)	M263	1	
9	LATHE-MIZER MANUAL (OPTION)	M1337	1	
	Electrical Diagrams			
10	ELECTRICAL INFORMATION (G25)	M2278	1	