

# **G16 Engine**

## **Safety, Operation, Maintenance & Parts Manual**

---

**1987 LT30**  
**1987 LT40**

**rev. A - AF**  
**rev. A - AL**

---



**Safety is our #1 concern!** Read and understand all safety information and instructions before operating, setting up or maintaining this machine.

*December 1996*

*Form #592*

# Table of Contents

# Section-Page

<b>SECTION 1</b>	<b>SAFETY &amp; GENERAL INFORMATION</b>	<b>1-1</b>
1.1	Refueling .....	1-1
1.2	Engine Operation.....	1-1
1.3	Battery Handling .....	1-2
<b>SECTION 2</b>	<b>OPERATION</b>	<b>2-1</b>
2.1	Starting The Engine.....	2-1
<b>SECTION 3</b>	<b>MAINTENANCE</b>	<b>3-1</b>
3.1	Air Filter & Pre-Cleaner.....	3-2
3.2	Debris Guard .....	3-3
3.3	Engine Oil.....	3-4
3.4	Air Cooling System .....	3-5
3.5	Fuel Filter .....	3-6
3.6	Battery .....	3-7
3.7	Drive Belt Adjustment.....	3-8
3.8	Miscellaneous Maintenance .....	3-9
3.9	RPM Adjustments .....	3-10
<b>SECTION 4</b>	<b>REPLACEMENT PARTS</b>	<b>4-1</b>
4.1	How To Use The Parts List .....	4-1
4.2	Sample Assembly .....	4-1
4.3	Fuel Tank/Tray Assembly .....	4-2
	<i>LT30</i> <i>Rev. AF - AG</i>	
	<i>LT40</i> <i>Rev. AJ - AL</i>	
4.4	Fuel Tank/Tray Assembly .....	4-4
	<i>LT30</i> <i>Rev. A - AE</i>	
	<i>LT40</i> <i>Rev. A - AH</i>	
4.5	Motor Mount Assembly .....	4-6
4.6	Engine Assembly.....	4-8
<b>SECTION 5</b>	<b>ELECTRICAL INFORMATION</b>	<b>5-1</b>
5.1	Electrical Symbol Diagram, LT30/LT40 Briggs & Stratton G16 .....	5-1
5.2	Electrical Components, LT30/LT40 G16.....	5-2
5.3	Battery Specifications, LT30/40 G16.....	5-3
5.4	Wiring Diagram, LT30/LT40 Briggs & Stratton G16.....	5-4

## SECTION 1 SAFETY & GENERAL INFORMATION



This symbol calls your attention to instructions concerning your personal safety. Be sure to observe and follow these instructions. This symbol accompanies a signal word. The word **DANGER** refers to hazards that can cause death or serious, irreversible personal injury. The word **WARNING** suggests a safety hazard that can cause personal injury. **CAUTION** refers to hazards that can cause damage to the equipment or property only.

Read all safety instructions before operating this equipment and observe all safety warnings! Read the manufacturer's operation manual and observe any additional safety warnings applicable to the specific make and model you have purchased.

### 1.1 Refueling



**WARNING!** Store gasoline away from sawdust and other flammable materials.

**WARNING!** Do not store gasoline near hot or burning materials.

**WARNING!** Do not smoke near gasoline storage tank or during refueling.

### 1.2 Engine Operation



**DANGER!** Do not operate engine in enclosed areas. Carbon Monoxide poisoning may occur.

**DANGER!** Do not operate engine without proper and operational spark arrester/muffler.



**WARNING!** The engine exhaust from this product contains chemicals known to the State of California to cause cancer, birth defects or other reproductive harm.

### 1.3 Battery Handling



**WARNING!** Batteries can explode when charging or boosting. Always wear eye protection.

**WARNING!** Keep cigarettes, flames or sparks away from battery.

**WARNING!** Charge the battery in a well-ventilated area. Do not attempt to charge a frozen battery.



**CAUTION!** Place a rag over battery vent holes when handling to avoid electrolyte squirting from holes.

## SECTION 2 OPERATION

### 2.1 Starting The Engine

To start the engine:

Turn the key switch on the control panel to the START position and release.

If the engine needs choking to start, pull the choke wire out until the engine starts. Push the choke wire in after the engine starts.

For more information, see the engine manufacturer's operation manual.

If the fuel tank was recently filled or replaced, squeeze the primer bulb once or twice before trying to start the engine. **NOTE:** If pumping problems are experienced, make sure the out-flow end of the hose line is connected to the carburetor. If pumping problems are still experienced, hold the primer bulb in a vertical position while squeezing. This allows the fuel check valve to operate properly.



**WARNING!** Do not start the engine when the clutch/brake lever is in the engaged (down) position. Always be sure the blade is disengaged and all persons are away from the blade before starting the engine.

**WARNING!** Make sure the carriage fwd/rev switch is in the neutral position before turning the key switch to the ON or ACC position. This will prevent unintended carriage movement.



## SECTION 3 MAINTENANCE



**IMPORTANT!** The Wood-Mizer maintenance schedule takes into account the specific use of engines in the Wood-Mizer sawmill. Therefore, the schedule may require certain procedures be performed at different time intervals than found in the engine manufacturer's manuals. Refer to the manufacturer's manual if you need more information on how to perform a procedure or on the engine itself.



**This symbol** identifies the interval (hours of operation) which each maintenance procedure should be performed. "AR" signifies maintenance procedures which should be performed as required.

### 3.1 Air Filter & Pre-Cleaner

4

Service the pre-cleaner every four hours of operation. Service by gently shaking excess sawdust and debris from the foam piece.

8

Clean the air filter (air cleaner element) and pre-cleaner (element wrapper) every eight hours of operation. See the engine manual for further instructions.

200

Replace the air filter (cleaner) every 200 hours of operation.

2000

Replace the pre-cleaner (element wrapper) every 2000 hours of operation.



## 3.2 Debris Guard



Clean the debris guard every 8 hours of operation. See engine manual for further instructions.

### 3.3 Engine Oil



Check the oil level every 8 hours of operation. Add oil as necessary. See the engine manual for oil viscosity and grade recommendations.



**IMPORTANT!** During initial break-in, change the oil after the first 5 hours and every 50 hours thereafter. Continue to check oil level every 8 hours of operation and refill as necessary.



### **3.4 Air Cooling System**

50

Wash the engine or brush off sawdust and debris every 50 hours of operation. Clean the spark arresters, breather pipe, cylinder head and cylinder cooling fins. Remove any dust, dirt or oil. See engine manual for further instructions.

### **3.5 Fuel Filter**



Replace the fuel filter every 100 hours of operation.

### 3.6 Battery



Check the battery electrolyte level every 50 hours of operation. See manufacturer's manual for instructions.



**WARNING!** Batteries contain explosive gases. Always wear eye protection and keep face away when charging or boosting battery. Charge battery in well-ventilated area. Keep battery away from hot or burning materials. Avoid spilling electrolyte when handling.

### 3.7 Drive Belt Adjustment

50

**See Figure 3-1.** Check the drive belt tension after the first 20 hours, and every 50 hours thereafter. The drive belt should have 7/16" (11 mm) deflection with a 14 lb. deflection force. To adjust the drive belt, remove the two belt covers located underneath the engine. To adjust the drive belt, loosen the bottom adjustment nut and tighten the top adjustment nut.

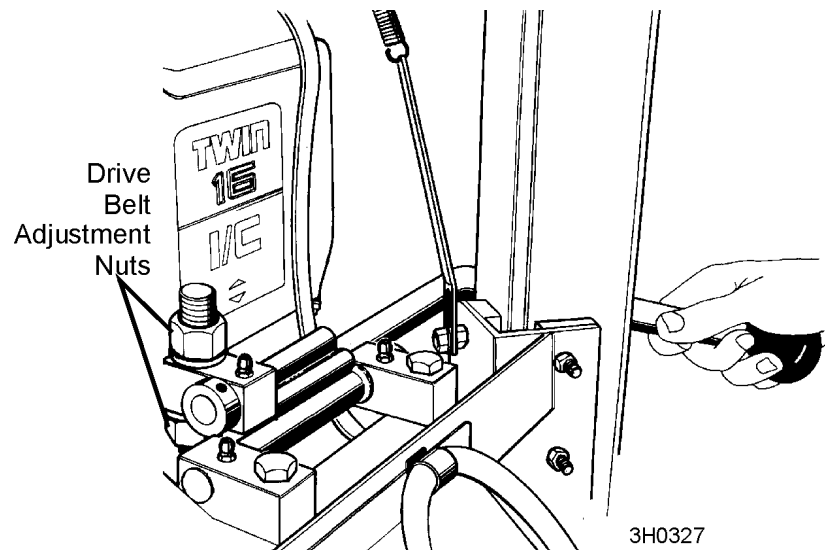

**FIG. 3-1**

AR

Periodically check all belts for wear. Replace any damaged or worn belts as needed.

### 3.8 Miscellaneous Maintenance

50

Clean and inspect the spark arresters every 50 hours of operation. Replace if damaged.

100

Inspect the spark plugs every 100 hour of operation. Remove any deposits and adjust gap if necessary. See engine manual for further information.

100

Clean carbon and lead deposits from the cylinder head every 100 hours of operation. See engine manual for further details.

500

Adjust the valve clearance every 500 hours of operation. See engine manual for further details.

### 3.9 RPM Adjustments



**DANGER!** Remove the blade from the sawmill before checking engine RPM.

200

Check the RPM with a tachometer after the first 20 hours of operation and every 200 hours thereafter. High-end RPM should be 3400-3600 RPM and low-end RPM should be 1800 ( $\pm 100$ ).

Before checking the RPM, make sure belt and brake strap tension are correct (See Sawmill Maintenance).

1. Start the engine to measure the low-end RPM.

**See Figure 3-2.** Make sure that the throttle linkage is not affecting the engine RPM while the clutch/brake handle is disengaged.

2. Refer to the engine manual to adjust the low-end RPM.
3. Engage the clutch handle to throttle the engine and measure the high-end RPM.

**See Figure 3-3. NOTE:** The engine should start to throttle as soon as you start moving the clutch handle down. If the engine dies instead, restart the engine and adjust the throttle linkage down as far as possible without affecting low-end RPM. With the engine idling and the clutch disengaged, loosen the mounting bolt and pull the throttle link down to a point just above where it affects the low-end RPM. Retighten the mounting bolt.

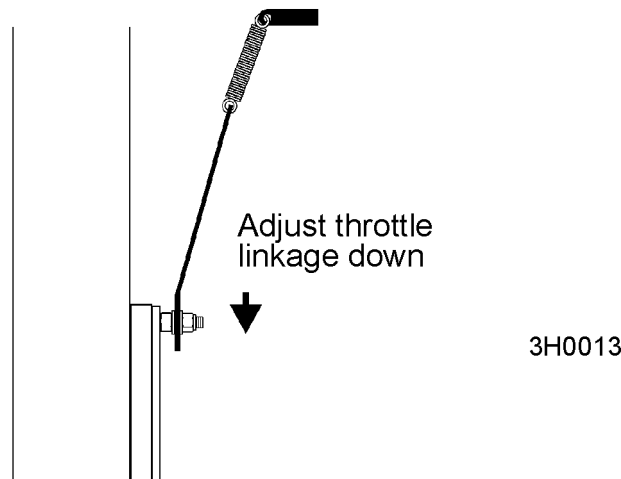

**FIG. 3-3**



## SECTION 4 REPLACEMENT PARTS

### 4.1 How To Use The Parts List

- Use the table of contents or index to locate the assembly that contains the part you need.
- Go to the appropriate section and locate the part in the illustration.
- Use the number pointing to the part to locate the correct part number and description in the table.
- Parts shown indented under another part are included with that part.
- Parts marked with a diamond (◆) are only available in the assembly listed above the part.

See the sample table below. Sample Part #A01111 includes part F02222-2 and subassembly A03333. Subassembly A03333 includes part S04444-4 and subassembly K05555. The diamond (◆) indicates that S04444-4 is not available except in subassembly A03333. Subassembly K05555 includes parts M06666 and F07777-77. The diamond (◆) indicates M06666 is not available except in subassembly K05555.

<b>4.2 Sample Assembly</b>				
REF	DESCRIPTION (◆ Indicates Parts Available In Assemblies Only)	PART #	QTY.	
	<b>SAMPLE ASSEMBLY, COMPLETE (INCLUDES ALL INDENTED PARTS BELOW)</b>	A01111	1	
1	Sample Part	F02222-22	1	
	Sample Subassembly (Includes All Indented Parts Below)	A03333	1	
2	Sample Part (◆ Indicates Part Is Only Available With A03333)	S04444-4	1	◆
	Sample Subassembly (Includes All Indented Parts Below)	K05555	1	
3	Sample Part (◆ Indicates Part Is Only Available With K05555)	M06666	2	◆
4	Sample Part	F07777-77	1	

**To Order Parts:**

- From the continental U.S., call **1-800-525-8100** to order parts. Have your customer number, vehicle identification number, and part numbers ready when you call.
- From other international locations, contact the Wood-Mizer distributor in your area for parts.

## 4

## Replacement Parts

### Fuel Tank/Tray Assembly

<b>4.3 Fuel Tank/Tray Assembly</b>				
<b>LT30</b>		<b>Rev. AF - AG</b>		
<b>LT40</b>		<b>Rev. AJ - AL</b>		
REF	DESCRIPTION (◆ Indicates Parts Available In Assemblies Only)	PART #	QTY.	
	<b>TANK ASSEMBLY, 3-GALLON RED GASOLINE</b>	A09694 <sup>1</sup>	1	◆
1	Tank, 3-Gallon Red Fuel	P09689 <sup>1</sup>	1	◆
2	Cap, 3 or 5-Gallon Fuel Tank	P09683	1	
3	Fitting, 1/4" NPT 90° Elbow	P09696	1	
4	Fitting, Male Disconnect	P07830 <sup>2</sup>	1	◆
	<b>TRAY ASSEMBLY, FUEL TANK</b>	A09692	1	
5	Tray, Fuel Tank	S09691	1	◆
6	Strap, 15" Rubber	P07461 <sup>3</sup>	2	
	Strap, 24" Rubber	P11258 <sup>3</sup>	2	
7	Bolt, 1/4-20 X 1" Carriage Head	F05005-34	2	
8	Nut, 1/4-20 Hex Lock	F05010-21	2	
	<b>HOSE, FUEL LINE WITH PRIMER BULB</b>	014497 <sup>4</sup>	1	
	Bulb Kit, Fuel Primer Replacement	014496 <sup>4</sup>	1	
9	Bulb, Fuel Primer	014481	1	◆
	Clamp, 7/32 - 1/2 Hose	P649 <sup>4</sup>	2	
	Instruction Sheet, Fuel Primer Bulb Replacement	014496-590	1	
	Hose, 1/4" ID Fuel	P642 <sup>4</sup>	6.5 Ft	
	Clamp, 7/32 - 1/2 Hose	P649 <sup>4</sup>	2	
10	<b>FITTING, 1/4" NPT FEMALE DISCONNECT</b>	P07831 <sup>2</sup>	1	◆
11	<b>O-RING KIT, METAL DISCONNECT FITTINGS</b>	P07832 <sup>5</sup>	1	

<sup>1</sup> 3-Gallon fuel tank A09694 replaced by A12285 5-Gallon tank. Upgrade requires two P11258 24" rubber straps and one P12176 Male Disconnect Fitting sold separately.

<sup>2</sup> Metal Disconnect fittings P07830 and P07831 replaced with plastic fittings P12175 & P12176. Replacement of fittings also requires qty. 1 hose clamp (P649).

<sup>3</sup> Use P07461 15" rubber strap for 3-Gallon fuel tank (replaces M07464 originally supplied). Use P11258 24" rubber strap to secure 5-Gallon fuel tank. Use P11668 20" rubber strap to secure original Unistream 3-gallon tank.

<sup>4</sup> Fuel Line Assembly w/Primer Bulb replaces P10083 originally supplied. UV-resistant primer bulb kit 014496 available separately. Fuel Line P642 replaces R01890-1 originally supplied. Hose Clamp P649 replaces plastic clamp P12374 previously supplied.

<sup>5</sup> Includes O-rings for male and female metal fittings. Fittings may be replaced with plastic fittings P12175 & P12176.

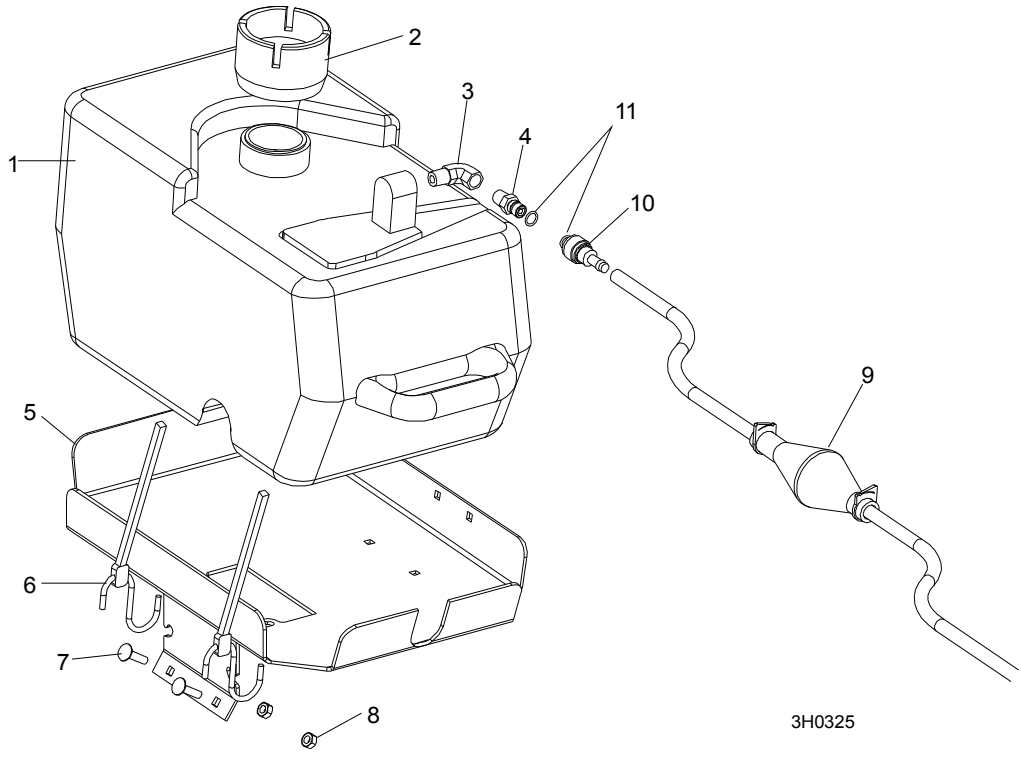

3H0325

FIG. 4-1

# 4

## Replacement Parts Fuel Tank/Tray Assembly

<b>4.4 Fuel Tank/Tray Assembly</b>				
<b>LT30</b>		<b>Rev. A - AE</b>		
<b>LT40</b>		<b>Rev. A - AH</b>		
REF	DESCRIPTION (◆ Indicates Parts Available In Assemblies Only)	PART #	QTY.	
	<b>TANK ASSEMBLY, 3-GALLON RED GASOLINE</b>	A07578 <sup>1</sup>	1	◆
1	Tank, 3-Gallon Red Fuel	P07463 <sup>1</sup>	1	◆
2	Fitting, Male Disconnect	P07830 <sup>2</sup>	1	◆
	<b>TRAY ASSEMBLY, FUEL TANK</b>	A07438 <sup>3</sup>	1	◆
3	Tray, Fuel Tank	S07515 <sup>3</sup>	1	◆
4	Strap, 20" Rubber	P11668 <sup>4</sup>	2	
5	Bolt, 1/4-20 X 1" Carriage Head	F05005-34	2	
6	Nut, 1/4-20 Hex Lock	F05010-21	2	
	<b>HOSE, FUEL LINE WITH PRIMER BULB</b>	014497 <sup>5</sup>	1	
	Bulb Kit, Fuel Primer Replacement	014496 <sup>5</sup>	1	
7	Bulb, Fuel Primer	014481	1	◆
	Clamp, 7/32 - 1/2 Hose	P649 <sup>5</sup>	2	
	Instruction Sheet, Fuel Primer Bulb Replacement	014496-590	1	
	Hose, 1/4" ID Fuel	P642 <sup>5</sup>	6.5 Ft	
	Clamp, 7/32 - 1/2 Hose	P649 <sup>5</sup>	2	
8	<b>FITTING, 1/4" NPT FEMALE DISCONNECT</b>	P07831 <sup>2</sup>	1	◆
9	<b>O-RING KIT, METAL DISCONNECT FITTINGS</b>	P07832 <sup>6</sup>	1	

<sup>1</sup> 3-Gallon fuel tank A07578 replaced by A12285 5-Gallon tank. Upgrade requires two P11258 24" rubber straps and one P12176 Male Disconnect Fitting sold separately. Requires modification of existing tray or replacement with larger tank tray A09692.

<sup>2</sup> Metal Disconnect fittings P07830 and P07831 replaced with plastic fittings P12175 & P12176. Replacement of fittings also requires qty. 1 hose clamp (P649).

<sup>3</sup> A07438 tray assembly obsolete. Use A09692 tray assembly (See Section 4.3). A09692 also required if tank upgraded to 5-Gallon tank. Use existing rubber straps or purchase two P11668 20" straps sold separately so secure original Unistream 3-Gallon tank.

<sup>4</sup> P11668 20" rubber strap replaces M07464 strap originally supplied.

<sup>5</sup> Fuel Line Assembly w/Primer Bulb replaces P10083 originally supplied. UV-resistant primer bulb kit 014496 available separately. Fuel Line P642 replaces R01890-1 originally supplied. Hose Clamp P649 replaces plastic clamp P12374 previously supplied.

<sup>6</sup> Includes O-rings for male and female metal fittings. Fittings may be replaced with plastic fittings P12175 & P12176.

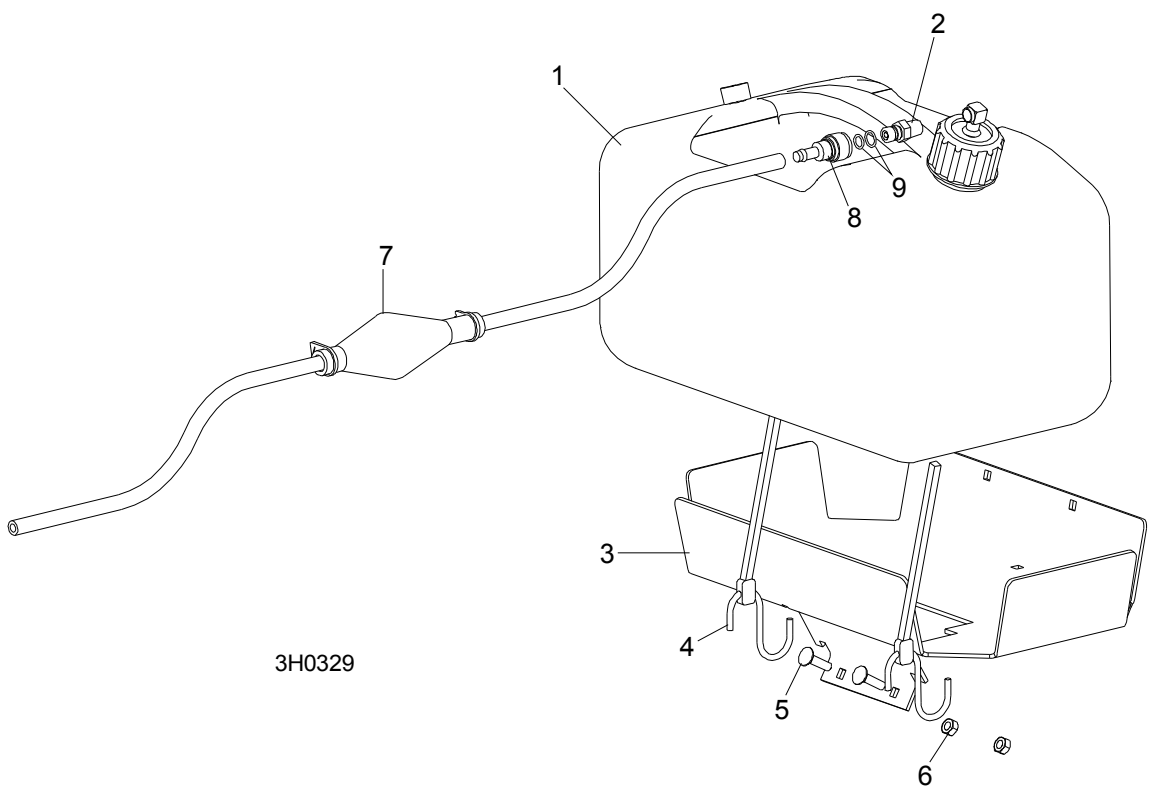

3H0329

FIG. 4-2

## 4

## Replacement Parts

## Motor Mount Assembly

<b>4.5 Motor Mount Assembly</b>				
<b>REF</b>	<b>DESCRIPTION</b> (◆ Indicates Parts Available In Assemblies Only)	<b>PART #</b>	<b>QTY.</b>	
1	<b>PLATE, MOTOR MOUNT</b>	W09543 <sup>1</sup>	1	
	<b>BUSHING ASSEMBLY, MOTOR MOUNT PIVOT</b>	A04127 <sup>2</sup>	2	◆
2	Bushing, Rubber Motor Mount Pivot	P12164	1	
3	Spacer, Motor Mount Pivot	P05041	1	
4	<b>PLATE, MOTOR MOUNT PIVOT BUSHING</b>	S04403	2	
5	<b>BOLT, 5/16-18 X 2 1/2" 'U'</b>	P05039	2	
6	<b>NUT, 5/16-18 HEX LOCK</b>	F05010-6	2	
7	<b>NUT, 1/2-13 NYLON LOCK</b>	F05010-8	2	
8	<b>PLATE, BRAKE STRAP CLAMP</b>	S04195	1	
9	<b>BOLT, 1/2-13 X 1 1/2" HEX HEAD</b>	F05008-3	2	
10	<b>BRACKET, MOTOR MOUNT HANGER</b>	W05028	1	
11	<b>BRACKET, MOTOR MOUNT ADJUSTABLE CLUTCH</b>	W05025	1	
12	<b>SPACER, MOTOR MOUNT BUSHING</b>	S07396	2	
13	<b>BUSHING, RUBBER MOTOR MOUNT</b>	P05032	2	
14	<b>PLATE, MOTOR MOUNT WASHER</b>	S05031	1	
15	<b>WASHER, 1/2" SPLIT LOCK</b>	F05011-9	2	
16	<b>NUT, 1/2-13 HEX LOCK</b>	F05010-3	2	
17	<b>GUARD, ENGINE BRUSH</b>	W09498 <sup>3</sup>	1	

<sup>1</sup> Replaces W04388 originally supplied.

<sup>2</sup> A04127 no longer available. Purchase individual component parts P12164 and P05041.

<sup>3</sup> Engine guard added 7/89. Can be retrofitted to older engines. Requires two F05006-13 5/16-18 x 2" Hex Head Bolts.

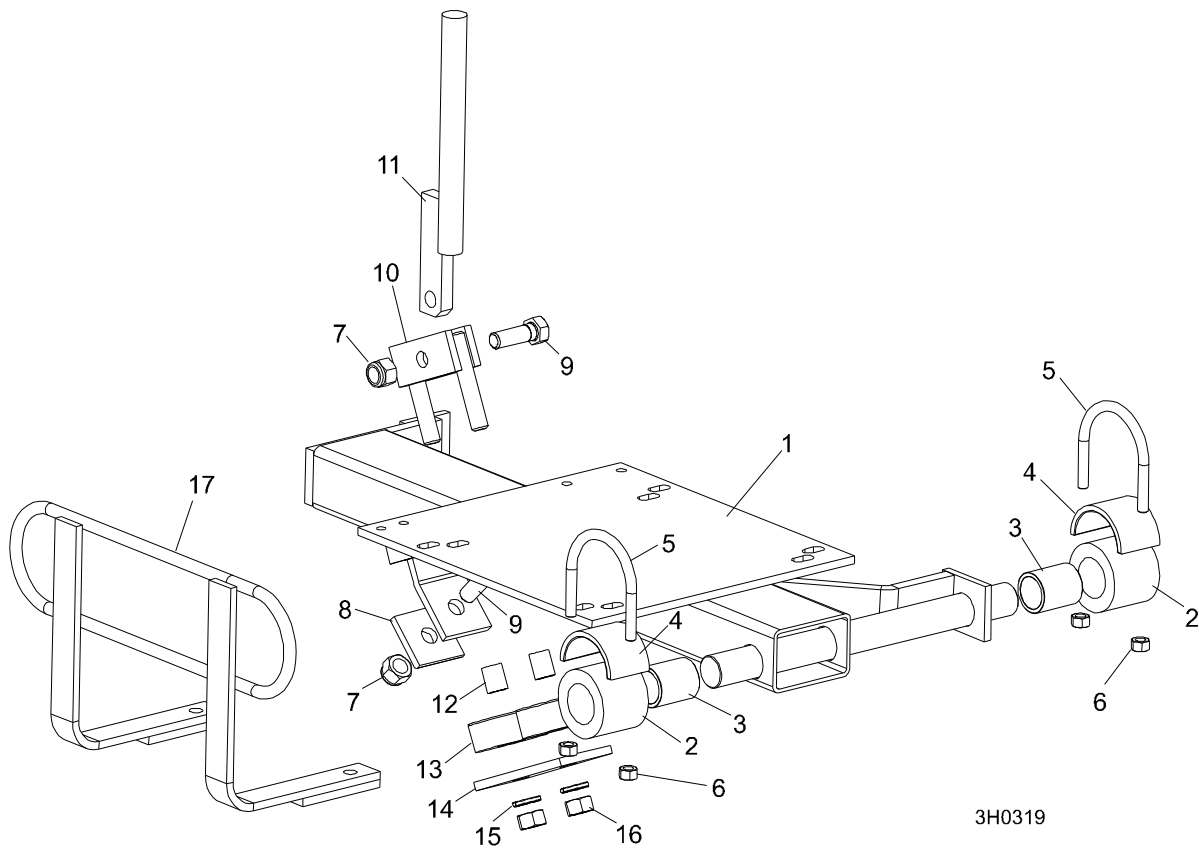

**FIG. 4-3**

## 4

## Replacement Parts

## Engine Assembly

<b>4.6 Engine Assembly</b>				
REF	DESCRIPTION (◆ Indicates Parts Available In Assemblies Only)	PART #	QTY.	
	<b>ENGINE ASSEMBLY, 16HP BRIGGS &amp; STRATTON</b>	A09551	1	◆
1	Engine, 16HP Briggs & Stratton Model I/C 402400	P09550 <sup>1</sup>	1	◆
2	Filter, Briggs 16/18HP Air	P09547	1	
3	Pre-Cleaner, Briggs 16/18HP Air	P09548	1	
4	Plug, Briggs Spark (Champion #RJ19LM)	P09586	2	
	Filter, In-Line Fuel	P07570	1	
	Spark Arrestor	P09553	1	
	Muffler, Briggs 16/18HP #491-307S	P08714	1	
5	Throttle Assembly, 16HP Briggs Engine	A09532	1	
6	Bracket, 16HP Briggs Throttle Mount	S09469	1	
7	Rod, 16HP Briggs Throttle Link	S09468	1	
8	Hose, 7" Oil Drain	P10082 <sup>2</sup>	1	
9	Cap, Oil Drain 3/8" Pipe	P04332	1	
	Oil, 10W30 Type CD	L04869-1	.38 Gal.	◆
10	Pulley, 2BK-34H Motor	P04853	1	
11	Key, 1/4" x 1/4" x 1 11/16"	S04124 <sup>3</sup>	1	
12	Bushing, 1" Split Taper	P09552	1	
13	<b>BELT, 2BX72 DRIVE</b>	P09555-2 <sup>4</sup>	1	
14	<b>BOLT, 5/16-18 X 2" HEX HEAD FULL THREAD</b>	F05006-13 <sup>5</sup>	2	
15	<b>BOLT, 5/16-18 X 1 1/2" HEX HEAD FULL THREAD</b>	F05006-2	2	
16	<b>WASHER, 5/16" SAE FLAT</b>	F05011-17	8	
17	<b>NUT, 5/16-18 HEX NYLON LOCK</b>	F05010-58	4	

<sup>1</sup> 16hp Briggs engines replaced by 18hp Briggs engine 1/88.

<sup>2</sup> Flexible drain hose replaces A09531 pipe drain supplied.

<sup>3</sup> 1-11/16" key replaces 1 1/4" or 2" key originally supplied.

<sup>4</sup> One double belt P09555-2 replaces two single belts P09555 originally supplied until 7/89.

<sup>5</sup> Engine guard added 7/89. Two F05006-13 5/16-18 x 2" Hex Head Bolts replace two F05006-2 5/16-18 x 1 1/2" Hex Head Bolts. See Section 4.5.



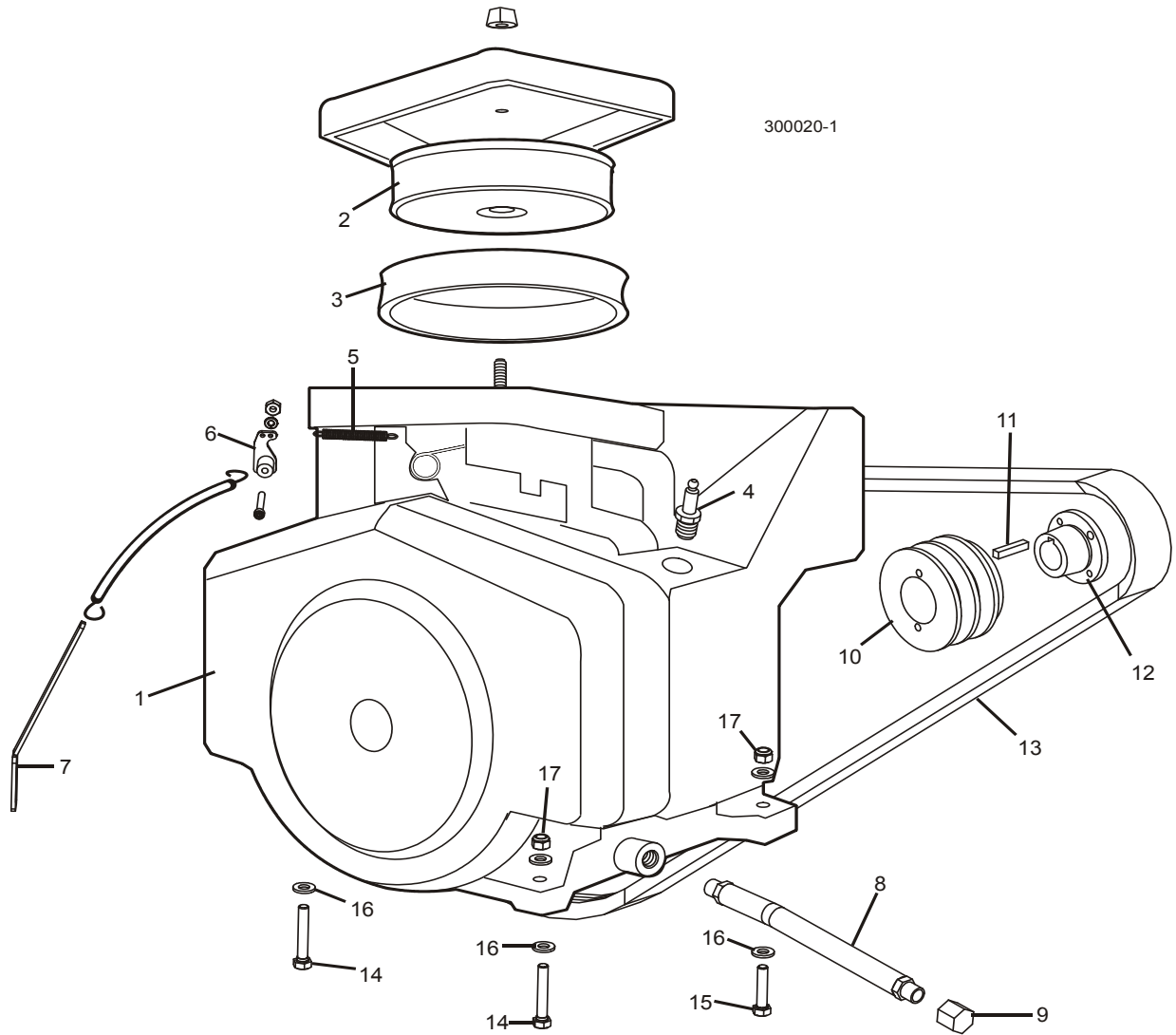
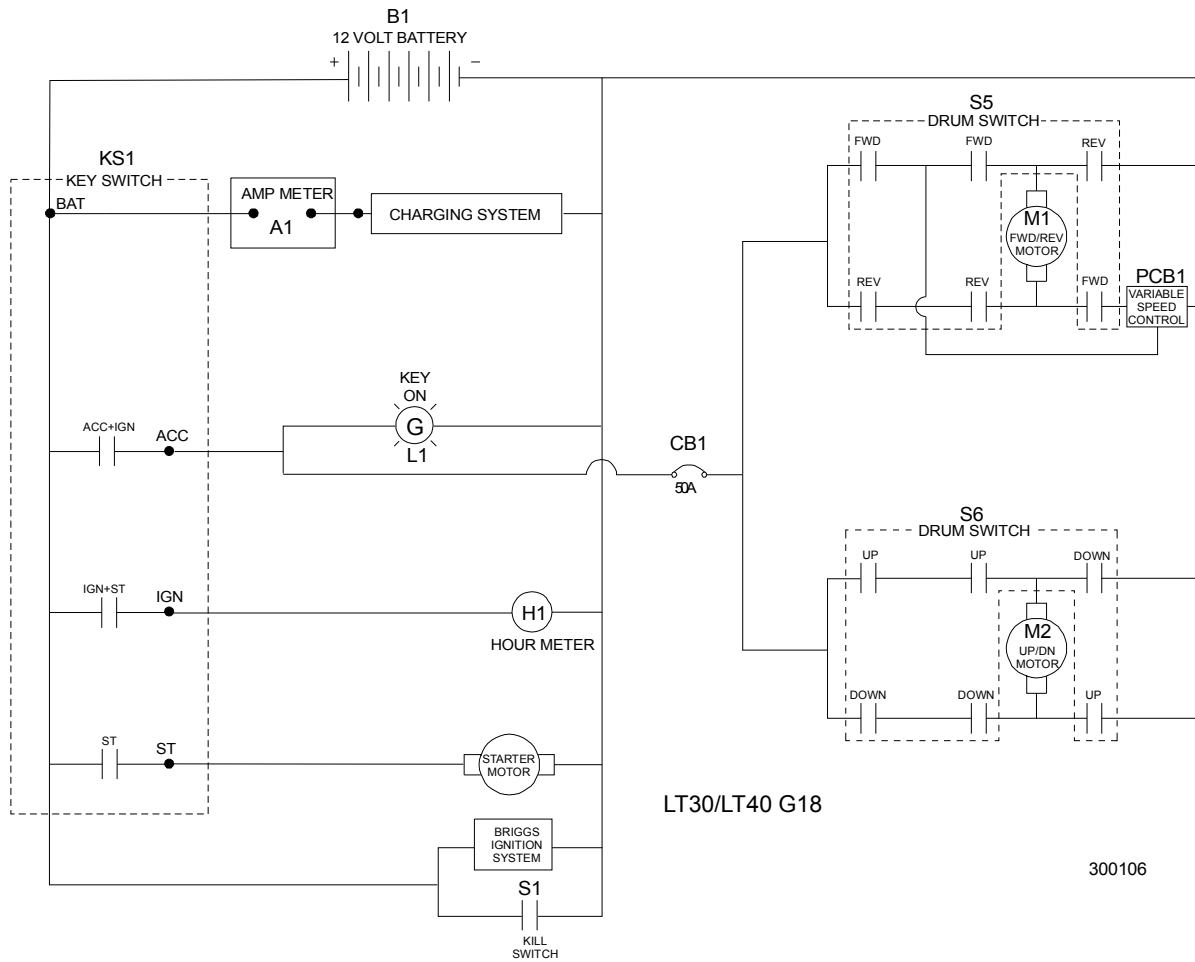

FIG. 4-4



SECTION 5 ELECTRICAL INFORMATION

5.1 Electrical Symbol Diagram, LT30/LT40 Briggs & Stratton G16



LT30/LT40 G18

300106

FIG. 5-1

## 5.2 Electrical Components, LT30/LT40 G16

Component	Manufacturer Part No.	Manufacturer	Wood-Mizer Part No.	Description
A1			P04270	Amp Meter
B1	93ET-DRY	Deka	P04325	Battery, 12 Volt ( <a href="#">See Section 5.3</a> )
CB1	30056-50	Cole-Hersee	A04706	Circuit Breaker, 50 Amp, 12 Volt Auto Reset
H1	T40 Series	ENM Corp.	P09631	Hour Meter, 12 Volt, Low Power T40 Series
KS1	121801	General	P04350	Key Switch, 4-position (Accessory, Off, Ignition, Start)
L1	2129	General	P20436	Light, Green Indicator, For Key Switch In Acc Or Ign Position
M1	A07974	Wood-Mizer	A07974	Motor, 12 Volt Power Feed
M2	PV-28147Q	Owosso	A04367	Motor, 12 Volt Up/Down
PCB1	A07800-W	Wood-Mizer	A07800-W	Control Assembly, Pre-92 Power Feed (includes items below & S5 Drum Switch)
	A07751	Wood-Mizer	A07751	Circuit Board, Pre-92 Power Feed
	A06963	Wood-Mizer	A06963	Module Assembly, MOSFET Power
	024756	Wood-Mizer	024756	Diode Assembly, Pre-92 Power Feed
	A07793	Wood-Mizer	A07793	Potentiometer, Power Feed
	P06257	Davies Molding	2300CK	Knob, Speed Control
S1	100-S	McGill	P07915 <sup>1</sup>	Engine Kill Switch
S5	2601-AG2-S14	Square D	A07799 <sup>2</sup>	Drum Switch, Power Feed Fwd/Reverse Motor
S6	2601-AG2-S13	Square D	A11758 <sup>3</sup>	Drum Switch, Up/Down Motor

<sup>1</sup> Part is obsolete and no longer available. Customer should be able to source locally.

<sup>2</sup> Replaces M04237 Dayton drum switch originally supplied until 1/91.

<sup>3</sup> Replaces A04705 Dayton drum switch w/spring originally supplied until 1/91. Replacement spring P04020 still available for old drum switch.

### 5.3 Battery Specifications, LT30/40 G16

Group No.	Type No.	Performance Level		Approximate Weight	Maximum Overall Dimensions		
		Cranking Performance	Reserve Capacity	Wet	Length	Width	Height
3ET	93ET-DRY	500CC	120	49.5 lb. (22.45 kg)	19.25 in. (489 mm)	4.25 in. (108 mm)	9.875 in. (251 mm)

**TABLE 5-1**

### 5.4 Wiring Diagram, LT30/LT40 Briggs & Stratton G16

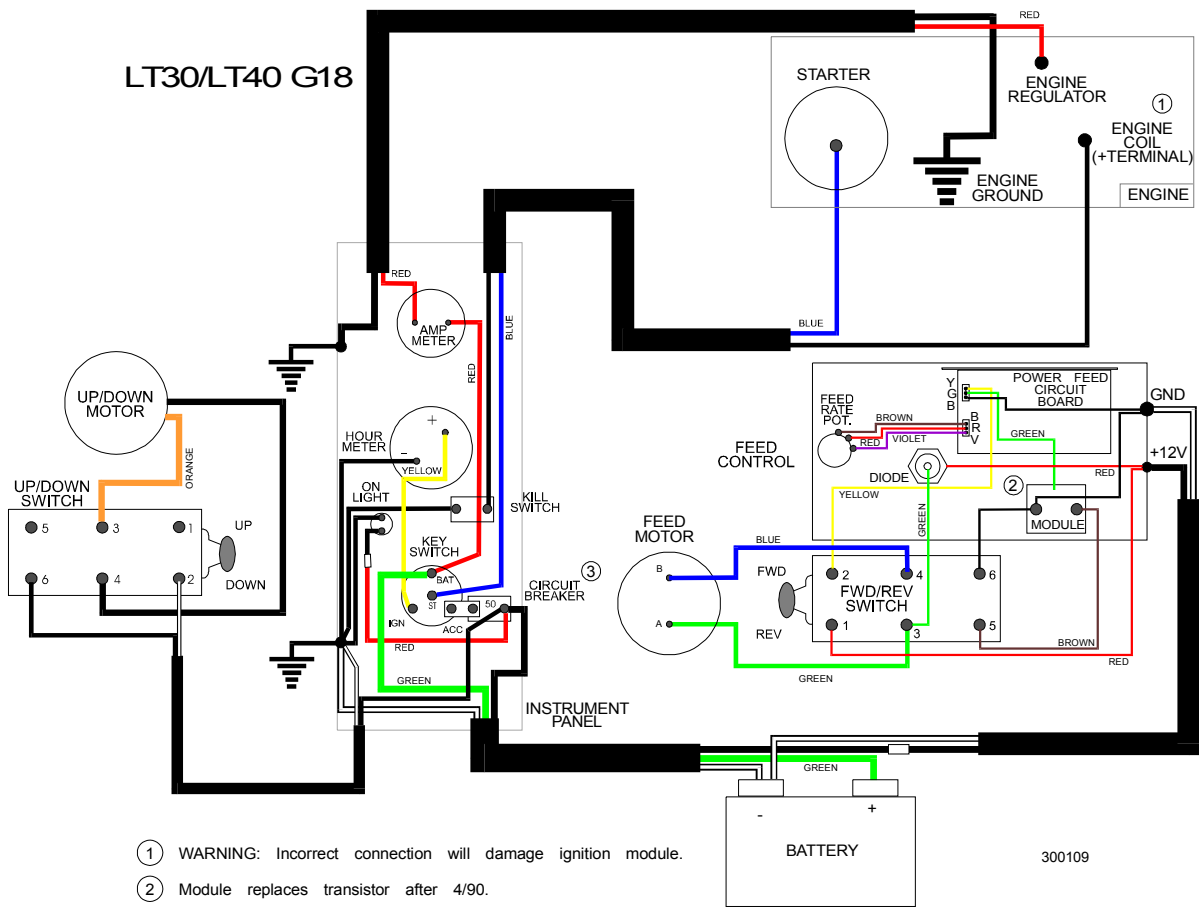

- ① WARNING: Incorrect connection will damage ignition module.
- ② Module replaces transistor after 4/90.
- ③ Circuit Breaker moved from battery box to instrument panel on LT30 after rev. AJ. Relocation of breaker on previous revisions is recommended.

300109

FIG. 5-2

---

## A

air cooling system 3-5

air filter 3-2

---

## B

battery handling 1-2

battery maintenance 3-7

---

## D

debris guard 3-3

---

## E

electrical components (LT30/LT40) 5-2

electrical symbol diagram 5-1

---

## F

fuel filter 3-6

---

## M

maintenance 3-1

miscellaneous maintenance 3-9

---

## O

oil 3-4

---

---

## P

parts list  
how to use 4-1

---

## R

refueling 1-1

replacement parts 4-1

RPM adjustments 3-10

---

## S

safety information 1-1

schematics 5-1

starting 2-1

---

## W

wiring diagram 5-4

---

