

APPENDIX A E15 ELECTRICAL INFORMATION

LT15EH15
LT15EH15W

Rev. E8.10+
Rev. A1.11+

LT15E15L 230V SYMBOL DIAGRAM

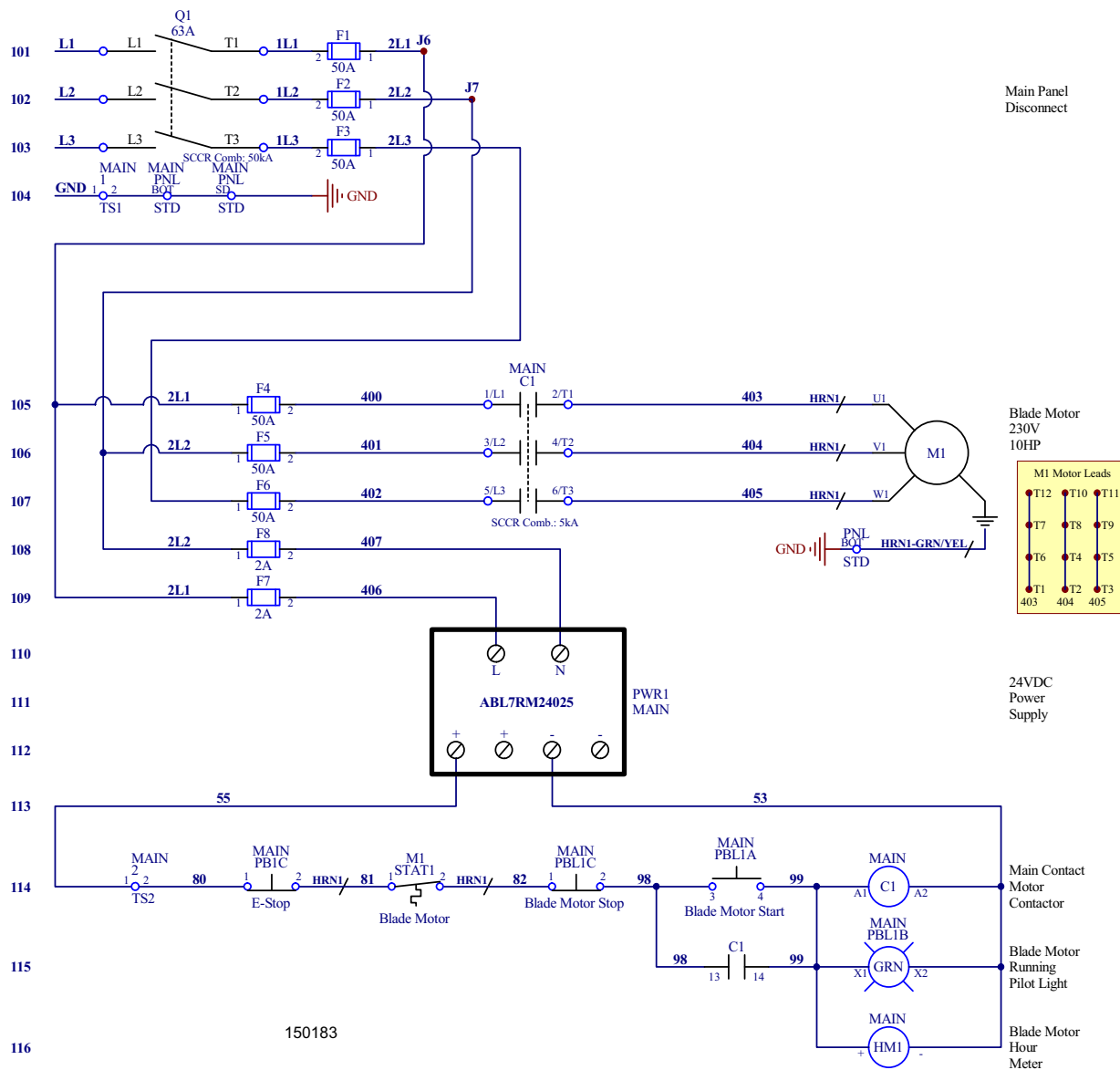

LT15EH15 SYMBOL DIAGRAM

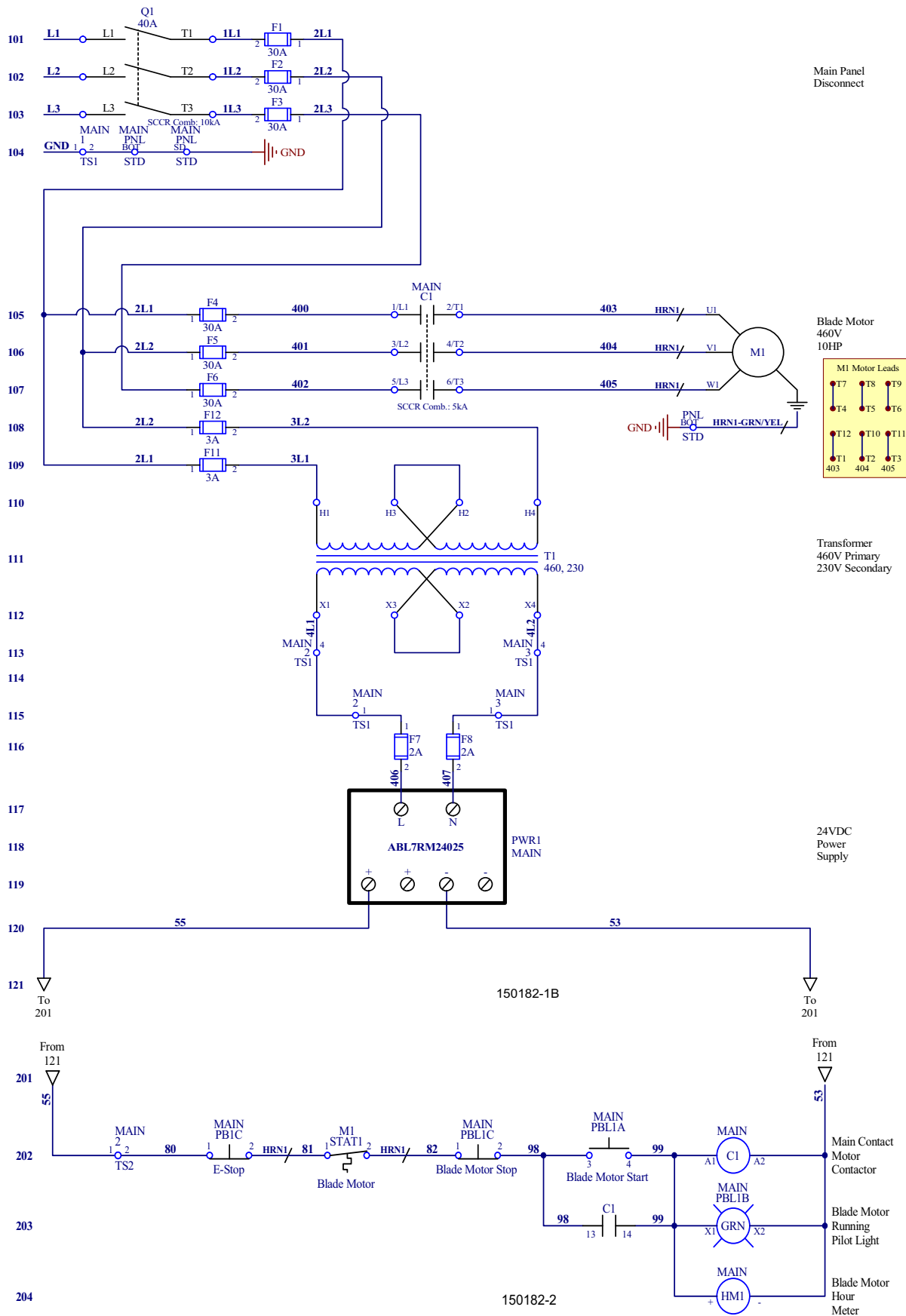

LT15EH15 Electrical Component List				
Item	Mfg. Part No.	Mfg.	Wood-Mizer Part No.	Description
C1	LC1D32BD	Schneider Electric	052465	Contact, 32A 3P 24VDC Coil
F1 - F6	TCFH60	Graybar Electric	053717	Fuseholder, 50A Cube
	25257712	Graybar Electric	053718	Fuse, 50A Class J Cube
F7 - F8	DFCC2V	Schneider Electric	052512	Fuseholder, 2P Class CC 30A Ind. DIN
	CCMR002	Standard Electric	E22716	Fuse, 2A 600A Class CC 5x20mm
HM1	732-0004	Redington Counters	015401	Hour Meter, 12 Volt DC
J6 - J7	222-413	Wago	052293	Junction Block, 3-Position Wire Clamp
M1	LM16019	Lincoln	034903	Motor, 10HP 3P 230/460V
PB1	ZB4BS54	Square D	024945	Switch Head, Red Push Button 22mm XB4
	ZB4BZ102	Square D	025161	Switch Body, 22mm 1NC ZB4
PBL1	ZB4BBW7L3741	Square D	051746	Switch Operator, 2 Button w/Pilot Red/Green
	ZBA710	Square D	052501	Boot, Clear Sealing ZB Switch
	ZB4BW0B31	Square D	025236-31	Switch Body, 22mm Green LED 1NO 24V ZB4
	ZBE102	Square D	050540	Contact, NC ZBE102
PWR1	ABL7RM24025	Schneider Electric	053591	Power Supply, 24VDC 60W
Q1	OT63F3	Vision Control	050881-1	Disconnect, 63Amp 600V 3P 6mm
	OHY65J6	RSA, Inc.	050907-1	Operator, Red/Yellow Pistol Grip 6mm
	OXP6X290	RSA, Inc.	050908-1	Shaft, Pistol Grip Disconnect 290mm x 6mm
TS1.1	Wago-283-107	Wago	068125	Terminal Block, Grounding
TS2.2	Wago-2004-1201	Wago	068106	Terminal Block, 2-Position

ELECTRICAL COMPONENT DIAGRAM (LT15EH15)

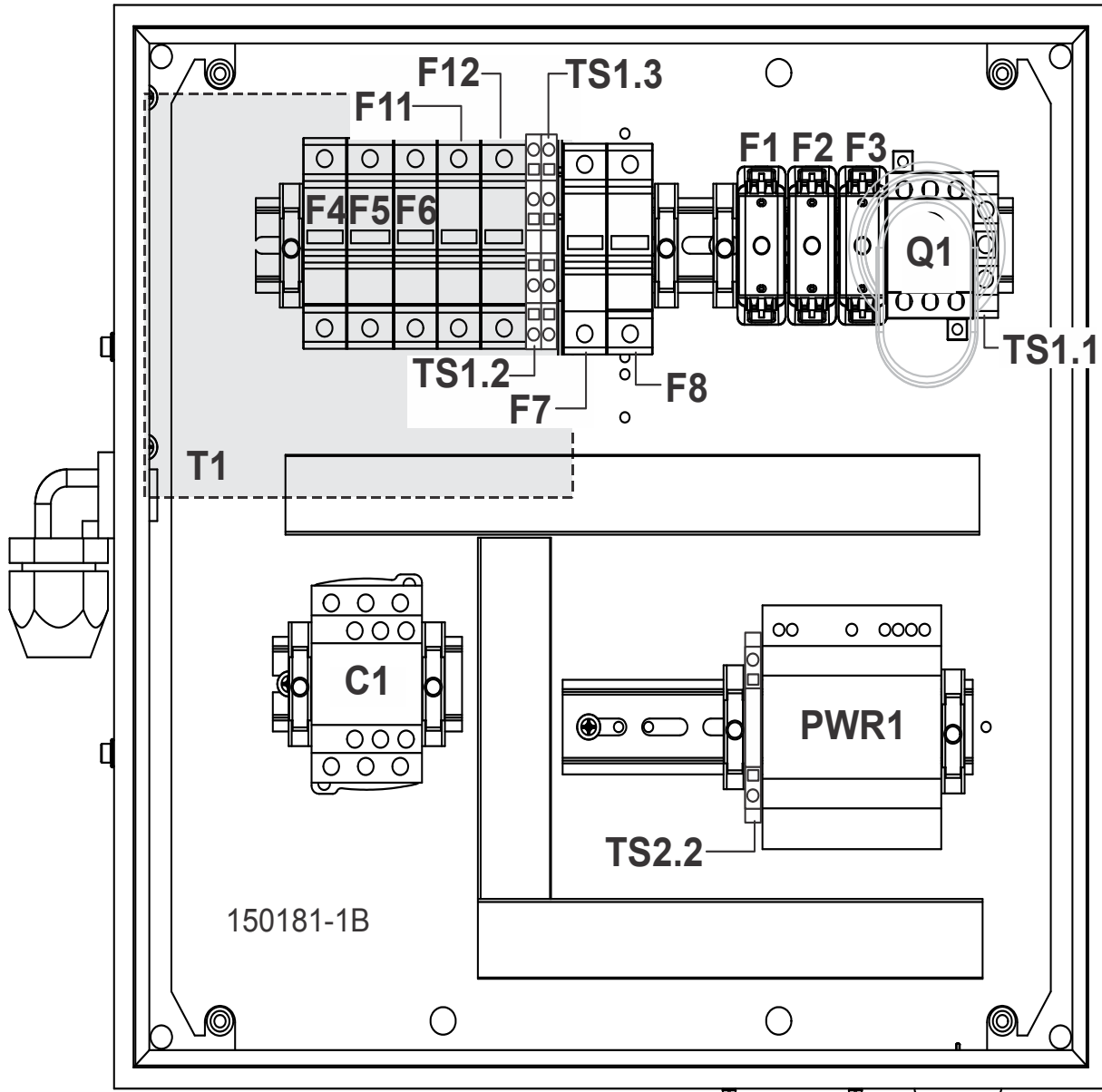

ELECTRICAL COMPONENT DIAGRAM (LT15EH15)

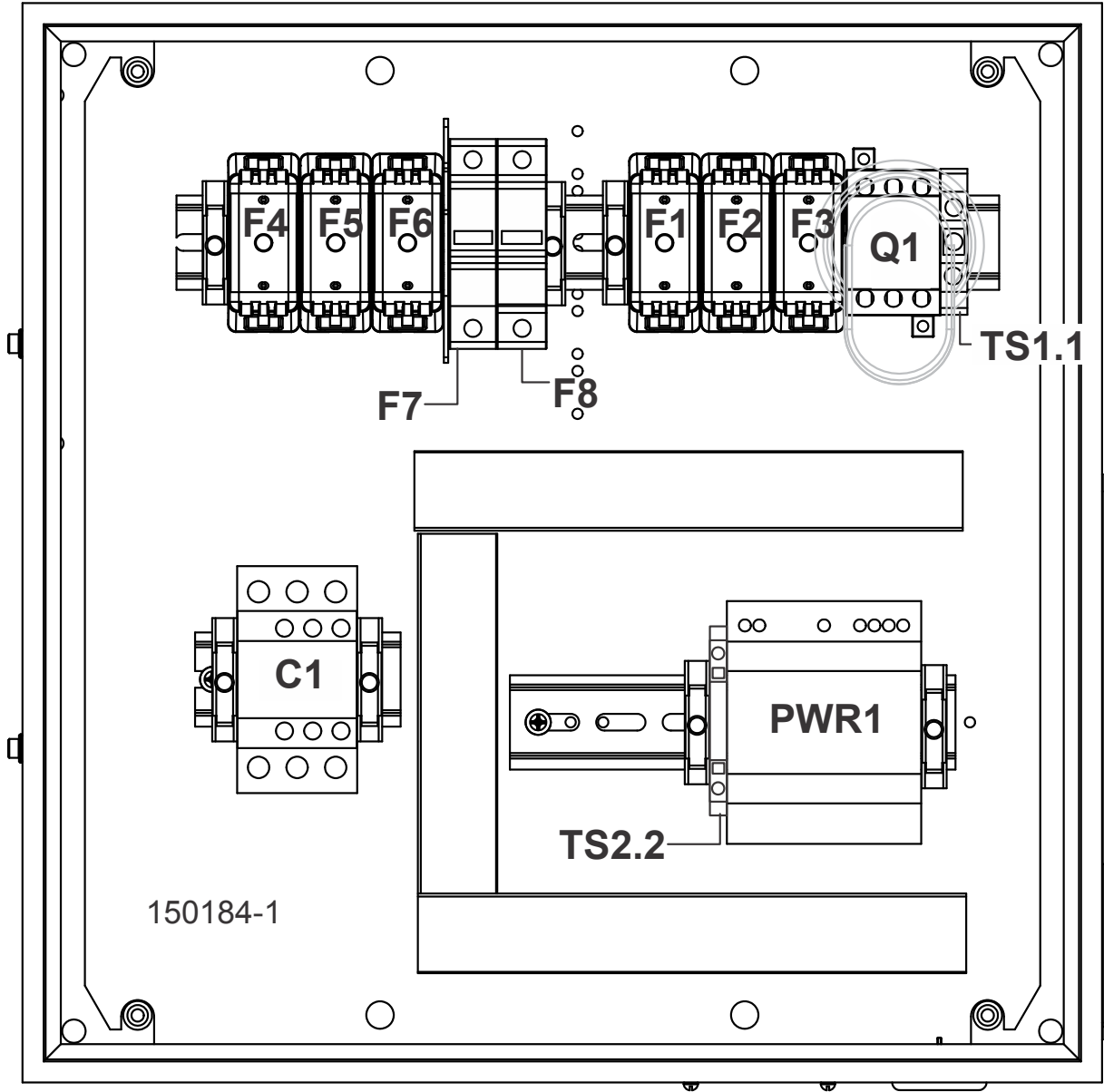

RIGHT SIDE COMPONENT DIAGRAM

