

# D36 Engine

## Safety, Operation, Maintenance & Parts Manual

---

<b>LT30</b>	<b>rev. K1.01 - K3.01</b>
<b>LT40</b>	<b>rev. K2.01 - K5.01</b>
<b>LT30HD</b>	<b>rev. K2.01 - K4.01</b>
<b>LT40HD</b>	<b>rev. K4.01 - K7.01</b>

---



**Safety is our #1 concern!** Read and understand all safety information and instructions before operating, setting up or maintaining this machine.

*January 2010*

*Form #1598*

## California

### Proposition 65 Warning



**WARNING:** Breathing gas/diesel engine exhaust exposes you to chemicals known to the State of California to cause cancer and birth defects or other reproductive harm.

Always start and operate the engine in a well-ventilated area.  
If in an enclosed area, vent the exhaust to the outside.  
Do not modify or tamper with the exhaust system.  
Do not idle the engine except as necessary.

For more information go to [www.P65warnings.ca.gov](http://www.P65warnings.ca.gov).



**WARNING:** Drilling, sawing, sanding or machining wood products can expose you to wood dust, a substance known to the State of California to cause cancer. Avoid inhaling wood dust or use a dust mask or other safeguards for personal protection.

For more information go to [www.P65Warnings.ca.gov/wood](http://www.P65Warnings.ca.gov/wood).

©2019

Printed in the United States of America, all rights reserved. No part of this manual may be reproduced in any form by any photographic, electronic, mechanical or other means or used in any information storage and retrieval system without written permission from

**Wood-Mizer**  
**8180 West 10th Street**  
**Indianapolis, Indiana 46214**

# Table of Contents

# Section-Page

<b>SECTION 1</b>	<b>ABOUT THIS MANUAL</b>	<b>1-1</b>
<b>SECTION 2</b>	<b>OPERATION</b>	<b>2-1</b>
2.1	Starting The Engine.....	2-1
<b>SECTION 3</b>	<b>MAINTENANCE</b>	<b>3-1</b>
3.1	Safety.....	3-1
3.2	Engine Oil & Filter.....	3-2
3.3	Cooling System.....	3-2
3.4	Battery.....	3-2
3.5	Alternator Belt.....	3-3
3.6	Air Cleaner.....	3-3
3.7	RPM Adjustments.....	3-3
<b>SECTION 4</b>	<b>REPLACEMENT PARTS</b>	<b>4-1</b>
4.1	Fuel Tank (D34/D36/D51).....	4-1
4.2	Engine Mount Assembly (D36).....	4-2
4.3	Engine Assembly.....	4-3
4.4	Relay/Throttle Assembly (D36).....	4-4
4.5	Muffler Assembly.....	4-6
4.6	Air Cleaner Assembly.....	4-7
4.7	Drive Assembly (D36).....	4-8
4.8	Radiator Assembly (D36).....	4-9
4.9	Alternator Assembly (D34/D36).....	4-11
4.10	Engine Pulley Guards (D34/D36/D51).....	4-12
	<b>INDEX</b>	<b>I</b>

# 1 About This Manual

## SECTION 1 ABOUT THIS MANUAL

This manual is provided as a supplement to the equipment manufacturer's manuals. This manual provides information specific to the use of this equipment on the Wood-Mizer® sawmill. Refer to the sawmill operator's manual and manufacturer's manual before attempting to operate this equipment.



**IMPORTANT!** Read the sawmill operator's manual and engine manufacturer's manual for instructions and safety precautions before operating this equipment.

The information and instructions given in this manual do not amend or extend the limited warranties for the equipment given at the time of purchase.

### D36 Engine

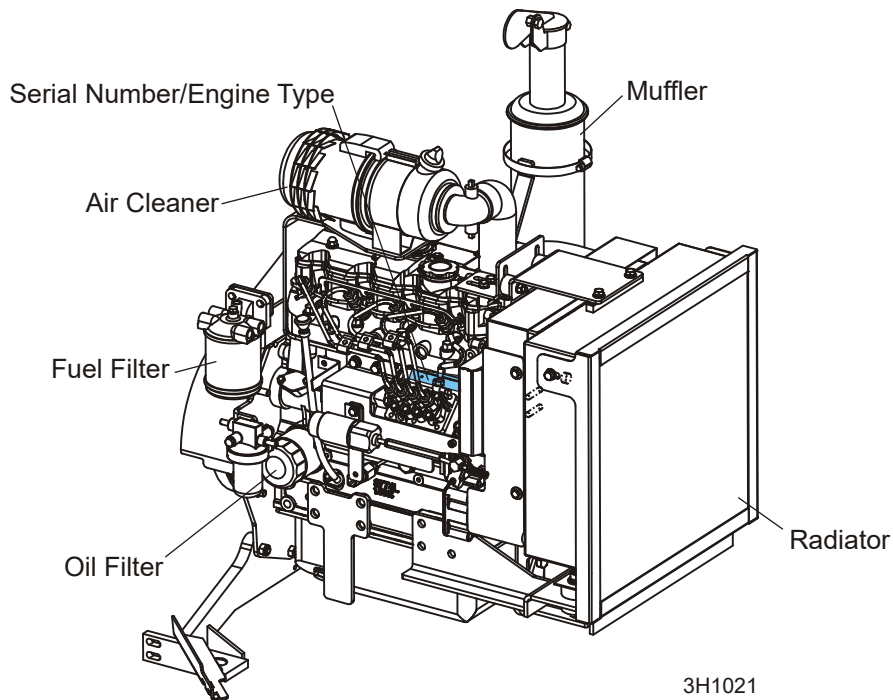

## SECTION 2 OPERATION

### 2.1 Starting The Engine

#### Engine Control Lights

**See Figure 2-1.** The following indicator lights are located on the sawmill control panel.  
 *Alternator Charge Indicator:* Lights up if the alternator is not charging the battery.



*Engine Temperature Indicator:* Lights up if the engine is overheating. A circuit breaker assembly in the engine harness will shut the engine off if the engine overheats. Turn the key switch off and allow the engine to cool for a period of time before restarting. If the overheating condition persists, stop operating the engine until the condition is corrected.



*Key Switch Indicator:* Lights up when the key is in either the on or accessory (#1 or #3) position.



*Oil Indicator:* Lights up if the oil pressure is too low. The engine will automatically switch to low idle if a low oil condition occurs.



*Glow Plug Indicator:* Lights up after the key has been turned to the on (#1) position.

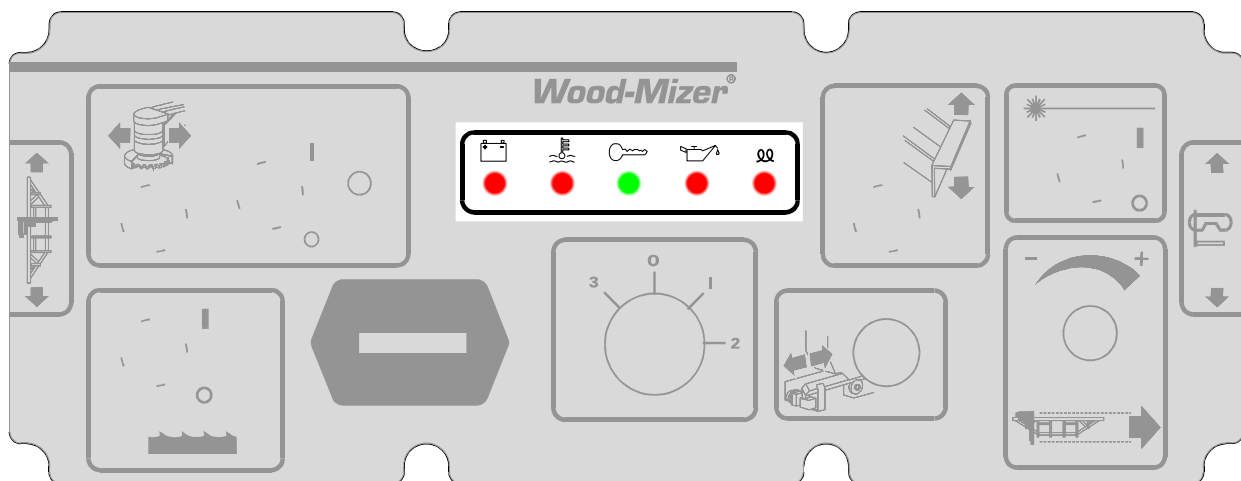

FIG. 2-1

## 2 Operation

### Starting The Engine

See Table 2-1. **IMPORTANT!** The glow plug sensing relay provides manual control of glow plug operation. See the table for recommended glow plug on times.

On Times For Manually Operated Glow Plugs	
Ambient Temperature	Suggested Glow Plug On Time
Less Than 32° F (0° C)	30 Seconds
32 - 60° F (0 -15° C)	25 Seconds
60 - 80° F (15 - 27° C)	15 Seconds
Above 80° F (27° C)	10 Seconds

TABLE 2-1 TIER2 ENGINE ONLY

**NOTE:** The glow plug light will stay on indefinitely when the key is in the pre-start (1) position. The glow plug light will go out after the engine is started.



**CAUTION!** Avoid leaving the key in the pre-start (1) position for more than 30 seconds while the engine is not running. Doing so will drain the sawmill battery which may reduce its service life.

### Engine Start



**DANGER!** Always be sure the blade is disengaged and all persons are out of the path of the blade before starting the engine. Failure to do so will result in serious injury.



**DANGER!** Operate your engine/machine only in well ventilated areas. The exhaust gases of your engine can cause nausea, delirium and potentially death unless adequate ventilation is present.



**DANGER!** Never operate an engine with a fuel or oil leak. The leaking fuel or oil could potentially come in contact with hot surfaces and ignite into flames.



**WARNING!** Be sure the power feed switch is in the neutral position before turning the key switch to the on (#1) or accessory (#3) position. This prevents accidental carriage movement, which may cause serious injury or death.



**WARNING!** Do not operate engine without proper and operational spark arrester/muffler. Sparks emitted from the engine exhaust could ignite surrounding materials, causing serious injury or death.



**CAUTION!** Do not crank starter for more than 20 seconds at one time during starting attempts. Damage to the engine may result.



**CAUTION!** Let engine idle for 2 minutes before applying load to prevent engine damage.

1. See the engine manufacturer's manual for lubricating oil recommendations for specific temperature ranges.
2. Use #2 or better quality diesel fuel for above freezing starting. Use a #1 quality diesel fuel for below freezing starting.
3. Turn the key switch on the control panel to the on (#1) position.
4. Wait the recommended glow plug on time (See [TABLE 2-1](#))
5. Turn the key switch to the start (#2) position and release.

### Engine Shutoff



**CAUTION!** A minimum 2 minute idle time is recommended to allow the battery charge to recover before the engine is shut off.

Turn the key switch to the off (#0) position.

## SECTION 3 MAINTENANCE

Refer to the manufacturer's manual for maintenance intervals and procedures unless otherwise instructed in this manual. Follow the manufacturer's recommendations for dusty conditions.



**IMPORTANT!** This manual only provides information about additional procedures or procedures to be performed at different time intervals than found in the manufacturer's manuals. Refer to the manufacturer's manual for complete maintenance instructions.



**WARNING!** Clean sawdust from all guards, vents, control boxes, or any area where sawdust may gather **after every shift**. Failure to do so may result in fire, causing death or serious injury.



### 3.1 Safety

Use caution when performing maintenance or service to the engine.



**DANGER!** Always be aware of and take proper protective measures against rotating shafts, pulleys, fans, etc. Always stay a safe distance from rotating members and make sure that loose clothing or long hair does not engage rotating members resulting in possible injury.

**DANGER!** Engine components can become very hot during operation. Avoid contact with any part of a hot engine. The exhaust components of your engine are especially hot during and following operation. Contact with hot engine components can cause serious burns. Therefore, never touch or perform service functions on a hot engine. Allow the engine to cool sufficiently before beginning any service function.



**WARNING!** Remove the blade before performing any engine service. Failure to do so may result in serious injury.

**WARNING!** Always wear proper and necessary safety equipment when performing service functions. Proper safety equipment includes eye protection, breathing protection, hand protection and foot protection.



**This symbol** identifies the interval (hours of operation) at which each maintenance procedure should be performed. "AR" signifies maintenance procedures which should be performed as required.



## 3.2 Engine Oil & Filter



Check the oil level every 8 hours of operation. Add oil as necessary. See the engine manual for oil viscosity and grade recommendations.

When checking the oil level, inspect the oil for indications of water in the oil. If there is water present or the oil is cloudy, DO NOT start the engine. Replace the oil and oil filter, run the engine at low idle for no more than 2 minutes and replace the oil and filter again.



**CAUTION!** Operating the engine with water in the engine oil will cause severe damage to the engine. Follow all maintenance procedures for checking oil level and oil/filter change intervals.



**IMPORTANT!** The engine is equipped with a muffler rain cap to keep water out of the muffler and engine. If the sawmill is stored outside or transported during rainy weather, the muffler must be covered.



Change the engine oil and oil filter after the first 50 hours of operation, then every 250 hours of operation.

## 3.3 Cooling System



Clean the radiator fins every 8 hours of operation. Spray the radiator with water from a hose or compressed air to clean sawdust from the radiator fins. Do not use a pressure sprayer.



**CAUTION!** Failure to keep the radiator fins clear of sawdust and/or dirt may cause the engine to overheat resulting in damage to the engine.

## 3.4 Battery



Check the battery electrolyte level every 50 hours of operation. See manufacturer's manual for instructions.



**DANGER!** Batteries expel explosive gases. Keep sparks, flames, burning cigarettes, or other ignition sources away at all times. Always wear safety goggles and a face shield when working near batteries. Failure to do so will cause serious injury.



**WARNING!** Battery posts, terminals and related accessories contain lead and lead compounds, chemicals known to the State of California to cause cancer and reproductive harm. Wash hands after handling.

### 3.5 Alternator Belt

The alternator belt is self-tensioning and should not need adjustment.

If the battery continues to not charge properly or the belt continues to squeal after the initial belt adjustment, replace the belt.

1. Release the blade tension and remove the blade from the sawmill if necessary. Turn the key switch to OFF (0) and remove the key.
2. Remove the drive belt cover and alternator cover.
3. While holding the idler up, install the new belt around the alternator and engine pulleys.
4. Release the idler on top of the belt and reinstall the alternator and drive belt covers.

### 3.6 Air Cleaner



Replace the air cleaner cartridge every 200 hours of operation. Change the cartridge more often if operating the sawmill in dirty conditions or if engine performance indicates a new cartridge is necessary.

### 3.7 RPM Adjustments



**WARNING!** Remove the blade before performing any engine service. Failure to do so may result in serious injury.



Check the RPM with a tachometer every 200 hours of operation.

See Table 3-1.

Engine	High End RPM	Low End RPM
D36	3150	1500

**TABLE 3-1**

Before checking the RPM, make sure belt and brake strap tensions are correct (See Sawmill Maintenance). Also check oil, fuel, and coolant levels.

Make sure the throttle solenoid linkage is adjusted properly. With the clutch disengaged, the throttle linkage should rest against the idle adjustment screw. With the clutch

engaged, the linkage should rest against the high-end adjustment screw and leave 0" to 1/32" of play in the linkage.



**CAUTION!** Failure to properly adjust the throttle solenoid linkage may cause damage to the solenoid.

1. Disengage the clutch and loosen the solenoid mounting bolts to adjust the throttle solenoid linkage.
2. Adjust the solenoid as far to the right as possible and retighten the mounting bolts.
3. Engage the clutch and recheck the amount of play in the linkage.

If there is more than 1/32" of play in the linkage with the clutch engaged, disengage the clutch and turn the linkage turnbuckle.

4. Repeat adjustments to achieve 0"-1/32" of play in the linkage with the clutch engaged.

See Figure 3-1.

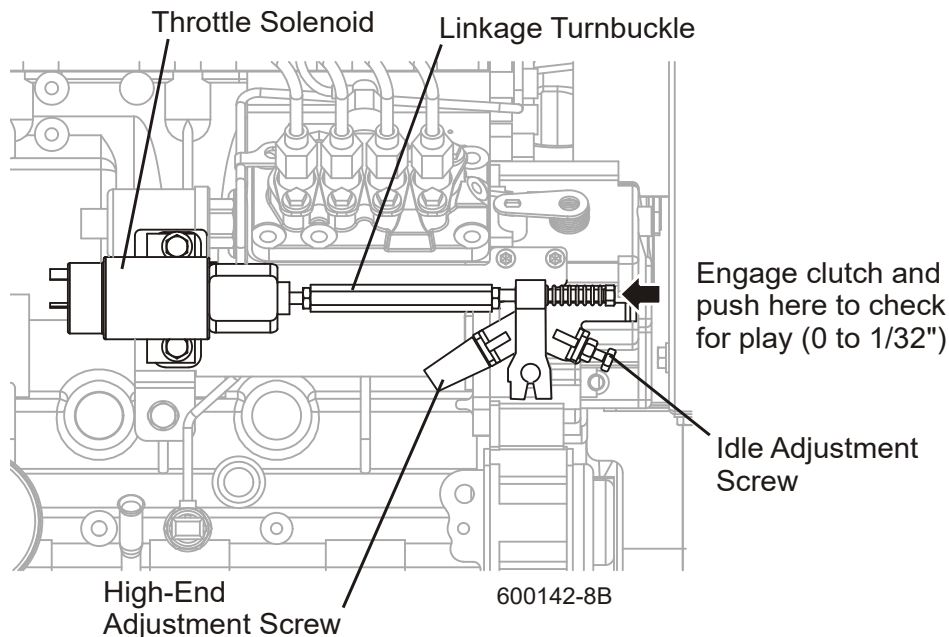

**FIG. 3-1**

5. Start the engine to measure the low-end RPM; let idle for 10 minutes.
6. With the engine at idle, adjust the low-end RPM to 1500. To decrease speed, loosen the idle adjustment screw. To increase speed, tighten the idle adjustment screw. The high-end adjustment screw should not be adjusted.

**3** **Maintenance**  
*RPM Adjustments*

---

# D36

## SECTION 4 REPLACEMENT PARTS

### 4.1 Fuel Tank (D34/D36/D51)

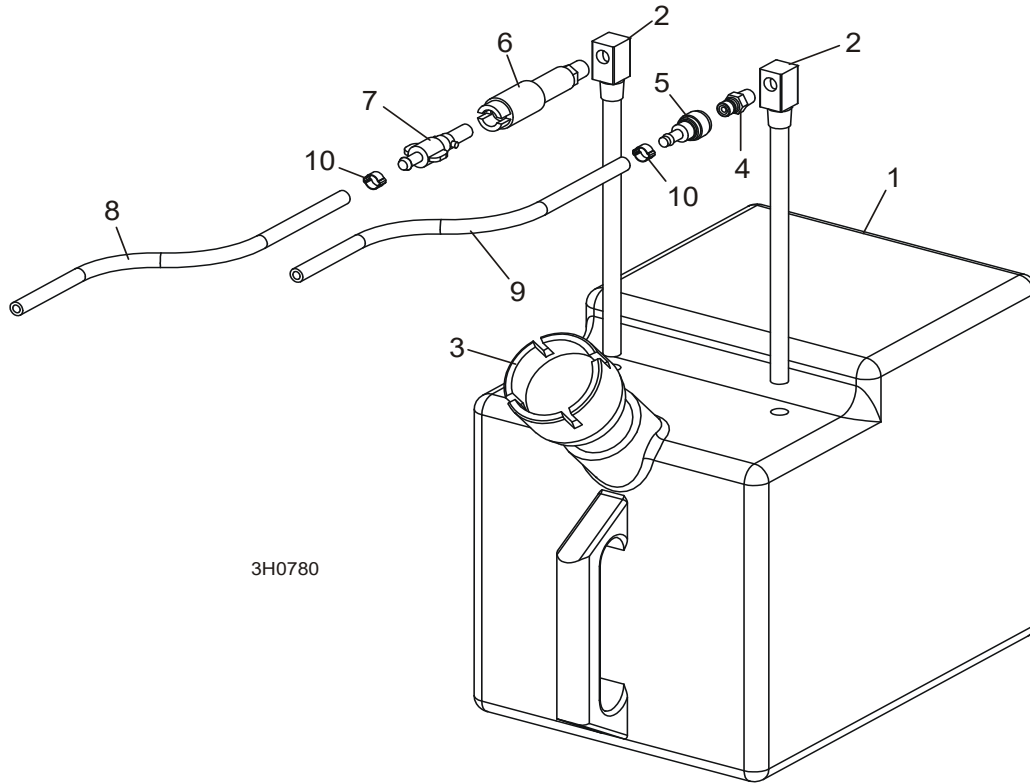

REF	DESCRIPTION (◆ Indicates Parts Available In Assemblies Only)	PART #	QTY.	
	<b>TANK ASSEMBLY, 5 GALLON DIESEL</b>	A12132	1	
1	Tank, 5 Gallon Fuel	P12166	1	◆
2	Pickup, 9" Fuel	P12172	2	
3	Cap, 3/5 Gallon Fuel Tank	P09683	1	
4	Fitting, 1/4" NPT Male Quick Disconnect	015583	1	
5	Fitting, Female Quick Disconnect Barb	015582	1	
6	Fitting, 1/4" NPT Plastic Female Disconnect	P12175	1	
7	Fitting, 1/4" Barb Plastic Male Disconnect	P12176	1	
8	<b>HOSE, 1/4" ID FUEL</b>	P642	7.1 Ft.	
9	<b>HOSE, 5/16" ID FUEL</b>	016338	9 Ft.	
10	<b>CLAMP, 7/32 - 1/2 HOSE</b>	P649	4	
	<b>ADDITIVE, DIESEL FUEL 16OZ BOTTLE</b>	004878 <sup>1</sup>	1	
	<b>BULB KIT, DIESEL PRIMER</b>	061080	1	

<sup>1</sup> Stanadyne Performance Formula helps eliminate contaminants and water in fuel, prevents gelling in cold weather, and improves lubrication of fuel system parts. 16 oz. bottle treats 60 gallons of diesel fuel.

# D36

## 4 Replacement Parts Engine Mount Assembly (D36)

### 4.2 Engine Mount Assembly (D36)

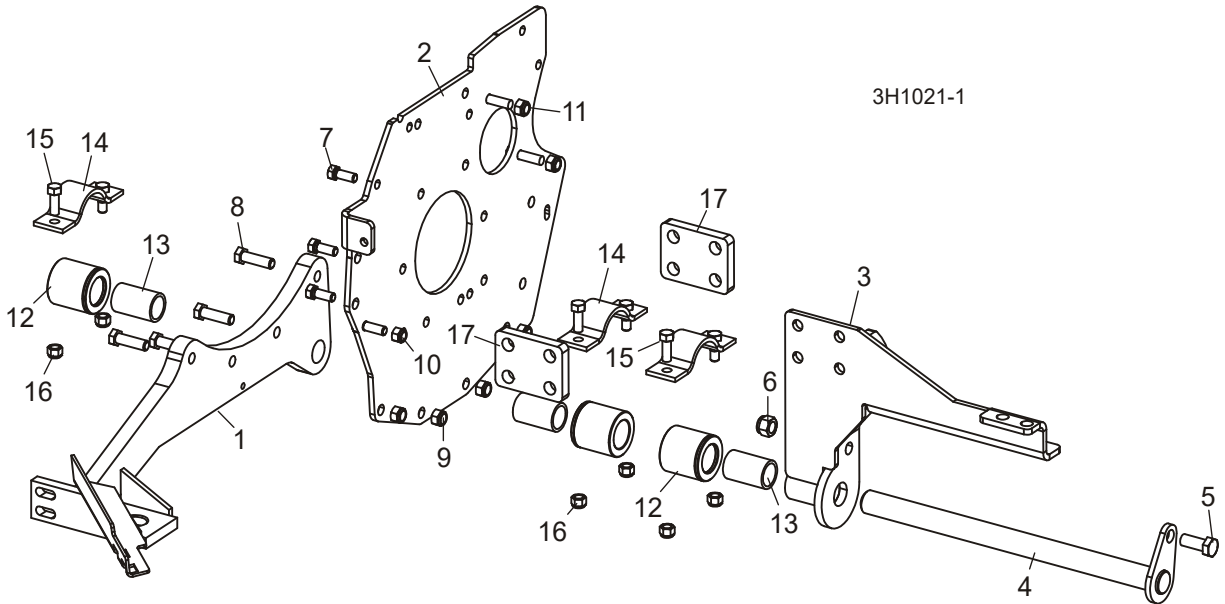

REF	DESCRIPTION (◆ Indicates Parts Available In Assemblies Only)	PART #	QTY.	
1	MOUNT WELDMENT, CAT ENGINE	046423	1	
2	MOUNT PLATE, CAT ENGINE REAR	058773	1	
3	MOUNT WELDMENT, CAT ENGINE FRONT	058754	1	
4	PIN WELDMENT, KUBOTA ENGINE MOUNT PIVOT	007399 <sup>1</sup>	1	
5	BOLT, 1/2-13 X 1 1/4" HEX HEAD GRADE 5	F05008-37	1	
6	NUT, 1/2-13 HEX NYLON LOCK	F05010-8	1	
7	BOLT, 3/8-16 X 1" HEX HEAD GRADE 5	F05007-87	3	
8	BOLT, 7/16-20 X 1 1/2" HEX HEAD FULL THREAD GRADE 5	F05007-156	4	
9	NUT, 7/16-20 HEX NYLON LOCK	F05010-83	4	
10	NUT, 3/8-16 HEX NYLON LOCK	F05010-10	1	
11	NUT, 10MM X 1.25" HEX NYLON LOCK	F81033-6	2	
	BUSHING ASSEMBLY, MOTOR MOUNT	016380	3	
12	Bushing, 2" OD x 2"	016378	1	◆
13	Bearing, 1" x 1 1/4" x 2"	016379	1	◆
14	CLAMP WELDMENT, MOTOR MOUNT	014540	3	
15	BOLT, 3/8-16 X 1" HEX HEAD	F05007-7	3	
16	NUT, 3/8-16 HEX NYLON LOCK	F05010-10	6	
17	PLATE, D36 MOTOR MOUNT	058767	2	

<sup>1</sup> Pin Weldment 007399 replaces 015855 originally supplied prior to 8/09. Longer pin allows complete engagement in motor mount bushings.

# D36

## 4.3 Engine Assembly

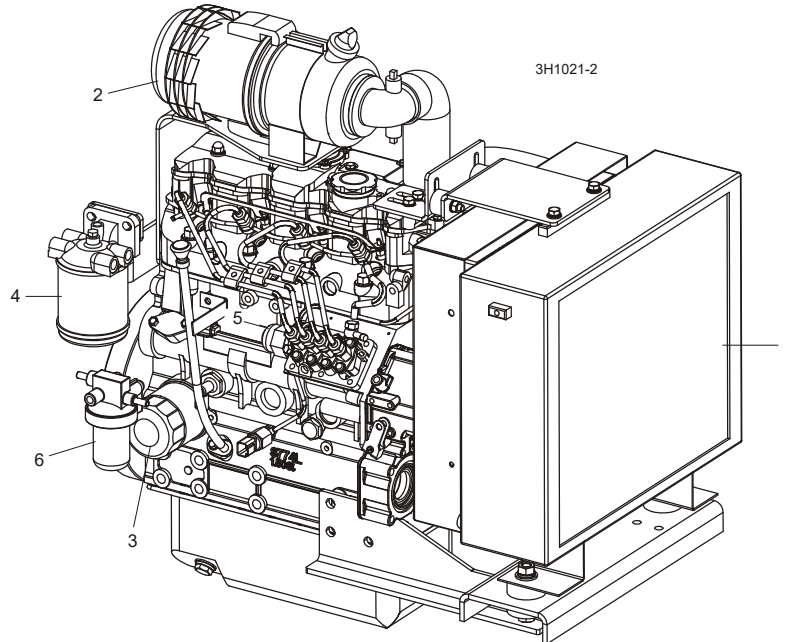

REF	DESCRIPTION (◆ Indicates Parts Available In Assemblies Only)	PART #	QTY.
	<b>COVER, ENGINE</b>	CED34	1
	<b>ENGINE, CATERPILLAR 36HP</b>	058751	1
<b>1</b>	Radiator Parts ( <a href="#">See Section 4.7</a> )		
<b>2</b>	Air Cleaner Parts ( <a href="#">See Section 4.6</a> )		
<b>3</b>	Filter, Caterpillar Oil #150-4140	046066	1
<b>4</b>	Filter Assembly, Caterpillar Fuel #033-7854	046069	1
	Filter, Caterpillar Fuel #067-6987	046068	1
	Pump, Caterpillar Fuel Transfer #176-7712	046070	1
	O-Ring, Caterpillar Fuel Pump Mount #176-7719	046071	1
<b>5</b>	Solenoid, Caterpillar Fuel Shutoff #217-5204	046072	1
<b>6</b>	Filter Assembly, Caterpillar Fuel/Water Separator #	046022	1
	Filter, Caterpillar Fuel/Water Separator #183-5446	046074	1
	O-Ring, Fuel/Water Separator Mount #183-5444	046075	1
	Plug, Caterpillar Glow #307-8672	061069	3
	Switch, Caterpillar Oil Pressure #217-5791	046077	1
	Switch, Caterpillar Water Temp #217-5793	046078	1
	Washer, Caterpillar Oil Pressure Switch Mount #153-5936	046079	1
	Starter, Caterpillar Engine #163-3361	046080	1
	Gasket, Caterpillar Exhaust Flange #153-7920	046067	1
	Gasket, Caterpillar Valve Cover #217-5866	046065	1
	Belt, D34 Fan (36") #1250-0366	054955	1
	<b>HEATER, CAT ENGINE BLOCK #3100049 (OPTIONAL)</b>	038422	1

# D36

## 4 Replacement Parts Relay/Throttle Assembly (D36)

### 4.4 Relay/Throttle Assembly (D36)

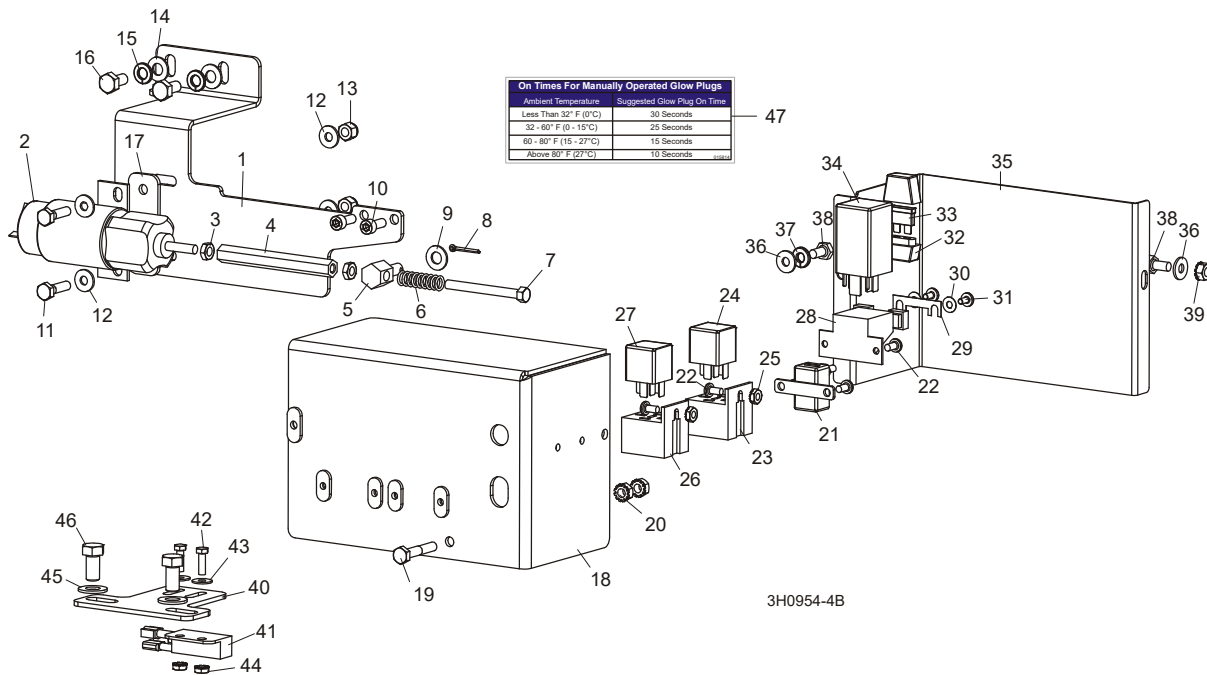

REF	DESCRIPTION (◆ Indicates Parts Available In Assemblies Only)	PART #	QTY.
1	<b>BRACKET, THROTTLE ACTUATOR MOUNT (D36)</b>	058758	1
	<b>SOLENOID KIT, THROTTLE, YANMAR/CAT</b>	074475	1
2	Solenoid, Throttle	045848	1
	Instruction Sheet, Solenoid Adjustment	074475-2058	1
3	<b>NUT, 1/4-28 HEX JAM</b>	F05010-113	2
4	<b>LINK, THROTTLE ACTUATOR</b>	045850	1
5	<b>PIN, THROTTLE ACTUATOR</b>	045849	1
6	<b>SPRING, .42" X 1.34" X .061"</b>	P11644	1
7	<b>BOLT, 1/4-28 X 2 1/2" HEX HEAD GRADE 5</b>	F05005-159	1
8	<b>PIN, 3/32" X 3/4" COTTER</b>	F05012-9	1
9	<b>WASHER, 5/16" SAE FLAT</b>	F05011-17	1
10	<b>BOLT, M6-1.0 X 16MM SOCKET HEAD</b>	F05004-206	2
11	<b>BOLT, 1/4-20 X 1" HEX HEAD GRADE 5</b>	F05005-101	2
12	<b>WASHER, 1/4" SAE FLAT</b>	F05011-11	4
13	<b>NUT, 1/4-20 HEX NYLON LOCK</b>	F05010-69	2
14	<b>WASHER, 5/16" SAE FLAT</b>	F05011-17	2
15	<b>WASHER, 5/16" SPLIT LOCK</b>	F05011-13	2
16	<b>BOLT, M8-1.25 X 16MM HEX HEAD</b>	F05004-47	2
17	<b>PLATE, THROTTLE SOLENOID SPACER</b>	046023	1
	<b>BRACKET ASSEMBLY, CATERPILLAR GLOW PLUG/THROTTLE RELAY (2005)</b>	052236	1
18	Bracket Weldment, Glow Plug Relay Mount	036269	1
19	Bolt, 1/4-20 x 1 1/2" Hex Head Full Thread	F05005-31	1



# D36

## Replacement Parts Relay/Throttle Assembly (D36)

**4**

20	Nut, 1/4-20 Self-Locking Hex	F05010-9	2	
21	Breaker, 15A Manual Reset Circuit	E20430	1	
22	Screw, #10-24 x 3/8" Phillips Head	F05004-3	6	
	Relay Assembly, Caterpillar Autoclutch Engage	051338	1	
	Socket Assembly, Throttle Relay Replacement	052829	1	
23	Socket, Relay Plug	050033	1	
24	Relay, Throttle	051335	1	
25	Nut, #10-24 Self-Locking Hex	F05010-14	2	
	Relay Assembly, Caterpillar Starter	051449	1	
	Socket Assembly, Starter Relay Replacement	052828	1	
26	Socket, Relay Plug	050033	1	
27	Relay, Starter	051335	1	
	Harness Assembly, Caterpillar Relay (2005)	052235	1	
	Socket Assembly, Glow Plug Relay Replacement	052827	1	
28	Socket, Glow Plug Relay w/Fuse Holder	024554	1	
29	Fuse Link, 50 Amp	024597	1	
30	Washer, M5 Wave	F81052-4	2	
31	Screw, M5-0.8 x 8mm Phillips Head Black Oxide	F81000-14	2	
32	Fuseholder, In-Line 3-20A ATC w/Cover	024555	1	
33	Fuse, 4A ATO Blade (Pink)	024150-4	1	
	Resistor Kit, Caterpillar Glow Plug	052663	1	
34	Relay, Glow Plug	023359	1	
35	<b>COVER, RELAY ASSEMBLY</b>	045824	1	
36	<b>WASHER, 1/4" SAE FLAT</b>	F05011-11	2	
37	<b>WASHER, 1/4" SPLIT LOCK</b>	F05011-14	1	
38	<b>BOLT, 1/4-20 X 1/2" HEX HEAD</b>	F05005-15	2	
39	<b>NUT, 1/4-20 SELF-LOCKING HEX</b>	F05010-9	1	
40	<b>BRACKET, SENSOR MOUNT</b>	016617	1	
41	<b>SENSOR, CATERPILLAR THROTTLE</b>	051436	1	
42	<b>BOLT, #10-24 X 5/8" HEX HEAD</b>	F05004-18	2	
43	<b>WASHER, #10 SAE FLAT</b>	F05011-18	2	
44	<b>NUT, #10-24 SELF-LOCKING HEX</b>	F05010-14	2	
45	<b>WASHER, 3/8" SAE FLAT</b>	F05011-3	2	
46	<b>BOLT, 3/8-16 X 3/4" HEX HEAD</b>	F05007-27	2	
47	<b>DECAL, GLOW PLUG OPERATION</b>	015814	1	

# D36

## 4 Replacement Parts Muffler Assembly

### 4.5 Muffler Assembly

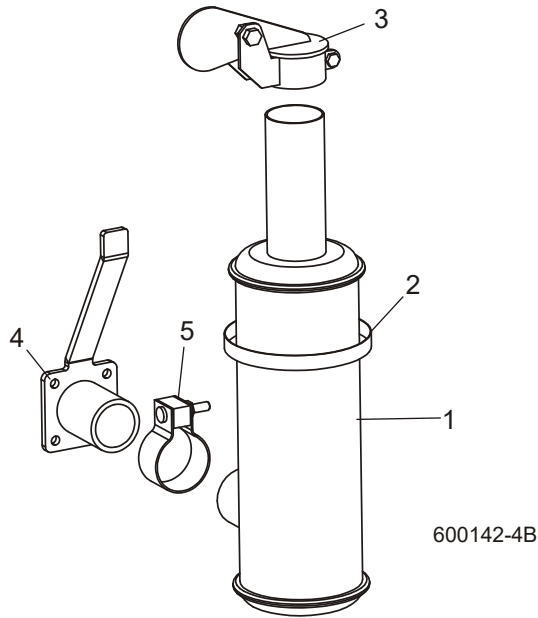

REF	DESCRIPTION (◆ Indicates Parts Available In Assemblies Only)	PART #	QTY.	
1	MUFFLER	014093	1	
2	CLAMP, 5" WORM	014096	1	
3	CAP, EXHAUST RAIN DEFLECTOR	038438	1	
4	BRACKET WELDMENT, MUFFLER MOUNT	045627	1	
5	CLAMP, MUFFLER 2" NELSON 90869A	014205	1	

# D36

## 4.6 Air Cleaner Assembly

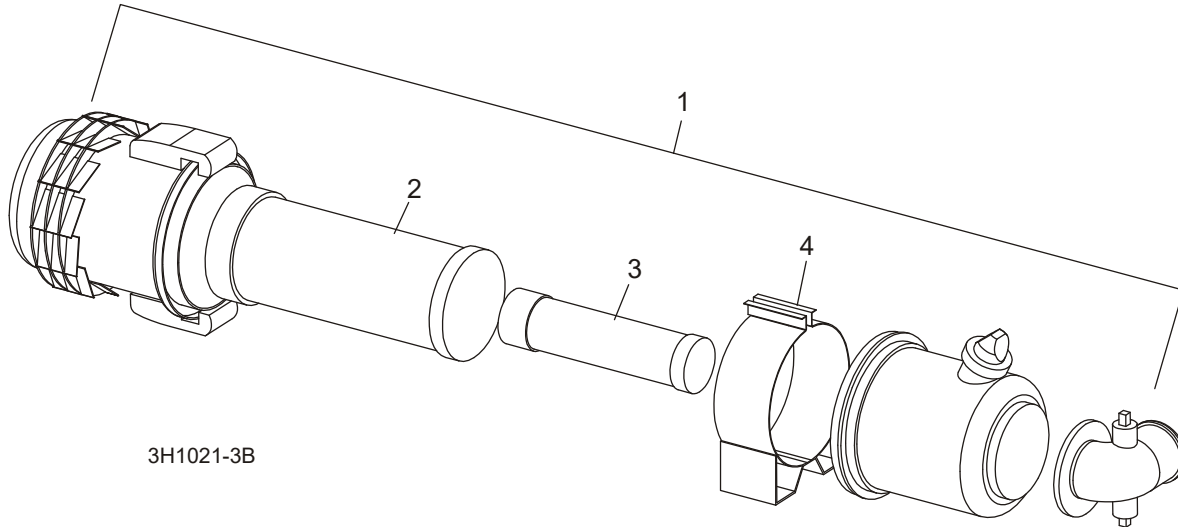

REF	DESCRIPTION (◆ Indicates Parts Available In Assemblies Only)	PART #	QTY.	
1	<b>CLEANER ASSEMBLY, CATERPILLAR #12000445</b>	069449	1	
2	Element, Air Cleaner Primary Caterpillar #2SE1	069450	1	
3	Element, Air Cleaner Secondary Caterpillar #2SE2	069451	1	
4	Strap, Cat Air Cleaner Mount	057785	1	

# D36

## 4

### Replacement Parts

#### Drive Assembly (D36)

#### 4.7 Drive Assembly (D36)

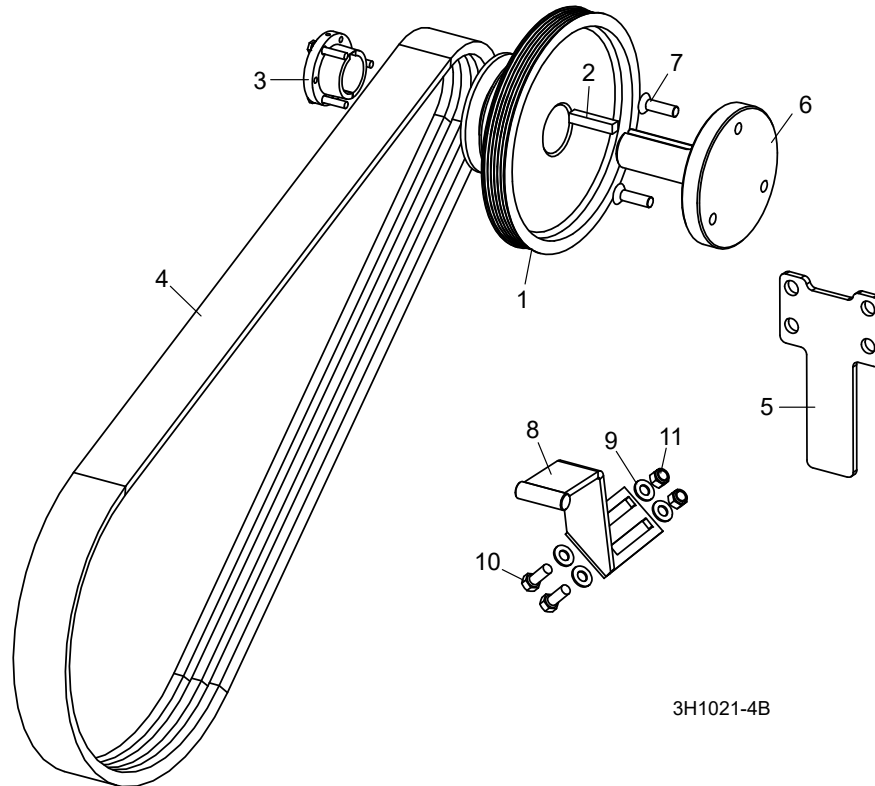

REF	DESCRIPTION (◆ Indicates Parts Available In Assemblies Only)	PART #	QTY.	
1	SHEAVE, 5V X 4.46" POLY V (GAS/DIESEL)	016533	1	
2	KEY, 3/8" X 3/8" X 1 7/8"	014693	1	
3	BUSHING, SH X 1 7/16"	016535	1	
4	BELT, 3/5VL770	046571	1	
5	PLATE, ENGINE STOP	058766	1	
6	SHAFT, CATERPILLAR DRIVE STUB	048448	1	
7	BOLT, M10-1.5 X 30MM FLAT SOCKET HEAD	F05007-246	3	
8	BRACKET, DRIVE BELT SUPPORT	016364	1	
9	WASHER, 3/8" SAE FLAT	F05011-3	4	
10	BOLT, 3/8-16 X 1" HEX HEAD	F05007-7	2	
11	NUT, 3/8-16 HEX NYLON LOCK	F05010-10	2	

# D36

## 4.8 Radiator Assembly (D36)

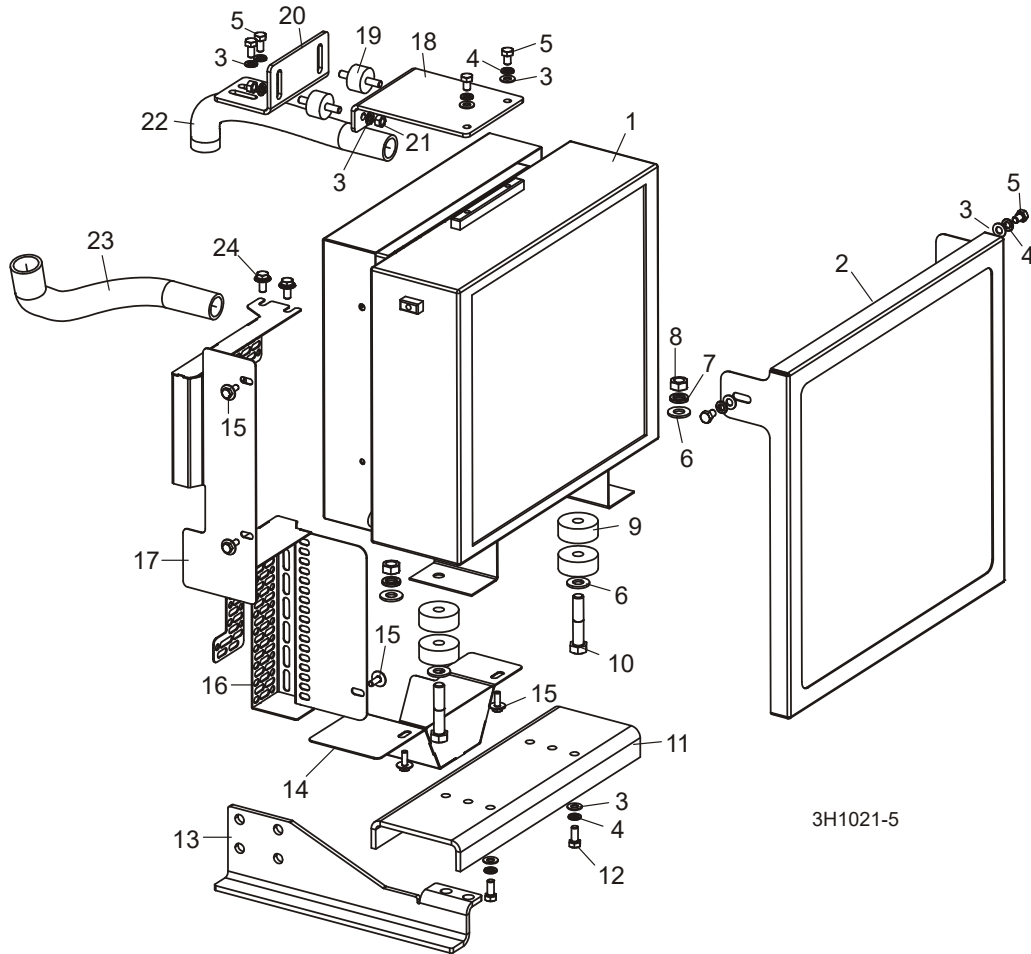

REF	DESCRIPTION (◆ Indicates Parts Available In Assemblies Only)	PART #	QTY.
1	RADIATOR, CATERPILLAR DIESEL ENGINE		1
2	GUARD WELDMENT, FRONT D36 RADIATOR	006692	1
3	WASHER, 5/16" SAE FLAT	F05011-17	6
4	WASHER, 5/16" SPLIT LOCK	F05011-13	10
5	BOLT, 5/16-18 X 1/2" HEX HEAD GRADE 5	F05006-15	2
6	WASHER, 1/2" SAE FLAT	F05011-2	4
7	WASHER, 1/2" SPLIT LOCK	F05011-9	2
8	NUT, 1/2-13 HEX	F05010-35	2
9	BUSHING, RUBBER ISOLATOR		4
10	BOLT, 1/2-13 X 2 1/2" HEX HEAD GRADE 5	F05008-74	2
11	BRACKET, LOWER RADIATOR MOUNT		1
12	BOLT, 5/16-18 X 3/4" HEX HEAD	F05006-5	2
13	BRACKET, D36 RADIATOR MOUNT		1
14	GUARD WELDMENT, D36 LOWER RADIATOR	058765	1

# D36

**4**

## Replacement Parts

*Radiator Assembly (D36)*

15	BOLT, 1/4-20 X 3/4" HEX W/CONICAL WASHER HEAD	F05005-134	5	
16	GUARD WELDMENT, D36 UPPER RADIATOR GUARD	058761	1	
17	GUARD WELDMENT, D36 SIDE RADIATOR GUARD	058772	1	
18	BRACKET, D36 TOP RADIATOR MOUNT			
19	BUSHING, UPPER RUBBER ISOLATOR			
20	BRACKET, D36 UPPER RADIATOR MOUNT			
21	NUT, 5/16-18 HEX	F05010-17	4	
22	HOSE, UPPER D36 RADIATOR		1	
23	HOSE, LOWER D36 RADIATOR		1	
24	BOLT, 5/16-18 X 3/4" HEX HEAD W/FLAT & LOCK WASHER	F05006-101	2	

# D36

## 4.9 Alternator Assembly (D34/D36)

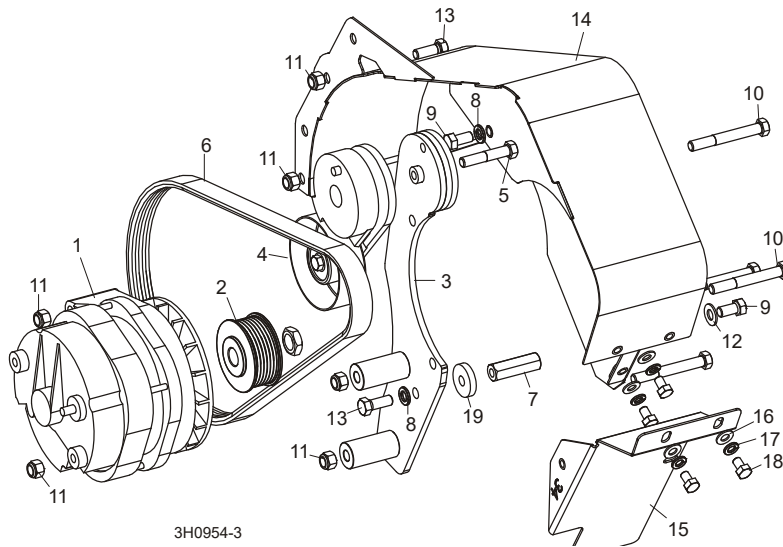

REF	DESCRIPTION (◆ Indicates Parts Available In Assemblies Only)	PART #	QTY.	
	Wire Assembly, Starter to Alternator	024308	1	
	Wire Assembly, Engine to Alternator Ground	050941	1	
	<b>ALTERNATOR ASSEMBLY, 140 AMP</b>	046429	1	◆
1	Alternator, 140 Amp	023695	1	
2	Pulley, 2 3/4" Dia. Alternator	046402	1	
3	<b>MOUNT WELDMENT, ALTERNATOR TENSION</b>	036740	1	
4	<b>TENSIONER, ALTERNATOR BELT</b>	034464	1	
5	<b>BOLT, 3/8-16 X 2" HEX HEAD GRADE 5</b>	F05007-124	1	
6	<b>BELT, 6PK1055 FIBERGLASS</b>	034513	1	
7	<b>SPACER, ALTERNATOR IDLER</b>	034771	1	
8	Washer, 3/8" Split Lock	F05011-4	2	
9	<b>BOLT, 3/8-16 X 3/4" HEX HEAD</b>	F05007-27	2	
10	<b>BOLT, 3/8-16 X 3" HEX HEAD GRADE 5</b>	F05007-73	4	
11	<b>NUT, 3/8-16 HEX NYLON LOCK</b>	F05010-10	6	
12	<b>WASHER, 3/8" SAE FLAT</b>	F05011-3	1	
13	<b>BOLT, 3/8-16 X 1" HEX HEAD GRADE 5</b>	F05007-87	3	
14	<b>GUARD WELDMENT, D34ALTERNATOR BELT</b>	047931	1	
15	<b>GUARD WELDMENT, LOWER D34 ALTERNATOR</b>	036742	1	
16	<b>WASHER, 5/16" SAE FLAT</b>	F05011-17	4	
17	Washer, 5/16" Split Lock	F05011-13	4	
18	<b>BOLT, 5/16-18 X 1/2" HEX HEAD GRADE 5</b>	F05006-15	4	
19	Washer, 3/8" ID x 1 1/4" OD	S02779	1	

**4** Replacement Parts  
*Engine Pulley Guards (D34/D36/D51)*

## 4.10 Engine Pulley Guards (D34/D36/D51)

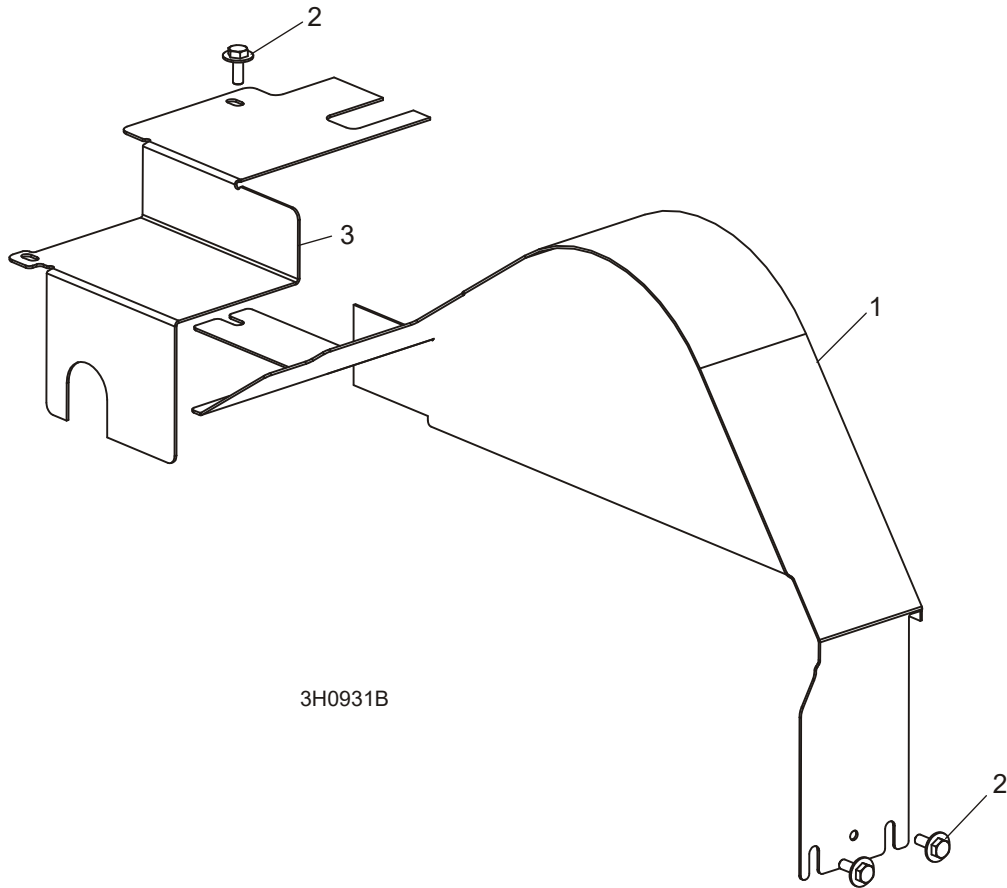

REF	DESCRIPTION (◆ Indicates Parts Available In Assemblies Only)	PART #	QTY.	
1	GUARD WELDMENT, CATERPILLAR ENGINE PULLEY	046560	1	
2	BOLT, 1/4-20 X 3/4" HEX HEAD WITH CONICAL WASHER	F05005-134	3	
3	GUARD, SIDE ENGINE PULLEY	016152	1	



# INDEX

---

## M

maintenance 3-1  
  air cleaner 3-3  
  alternator belt 3-3  
  battery 3-2  
  cooling system 3-2  
  engine oil 3-2  
  RPM adjustments 3-3  
  safety 3-1

---

## O

operation 2-1  
  control lights 2-1  
  shutoff 2-3  
  starting 2-2

---

## P

parts list  
  air cleaner assembly 4-7  
  alternator 4-11  
  drive assembly 4-8  
  engine mount assembly 4-2  
  fuel tank 4-1  
  muffler assembly 4-6  
  pulley guards 4-12  
  radiator assembly 4-9  
  relay/throttle assembly 4-4