

G28 Engine

Safety, Operation, Maintenance & Parts Manual

036355 Engine Assy, Kohler 28hp rev. D

Safety is our #1 concern!

January 2010

Form #1159

LT30G28 (OBS 11/06)	rev. J6.00 - J8.02
LT40G28 (OBS 10/13)	rev. J7.00 - K4.04
LT30HDG28 (OBS 10/08)	rev. J7.00 - K2.00
LT40HDG28 (OBS 10/13)	rev. J8.00 - K6.04

*

**Note: LT40G28/LT40HDG28 mills built after
rev. K4.00 and K6.00 respectively
(3/17/2011) will have G29 Kohler engines.
See the G29 manual for those mills.**



**WARNING! Read and understand this
manual before using this machine.**

California
Proposition 65 Warning



WARNING: Breathing gas/diesel engine exhaust exposes you to chemicals known to the State of California to cause cancer and birth defects or other reproductive harm.

Always start and operate the engine in a well-ventilated area.
If in an enclosed area, vent the exhaust to the outside.
Do not modify or tamper with the exhaust system.
Do not idle the engine except as necessary.

For more information go to **www.P65warnings.ca.gov**.



WARNING: Drilling, sawing, sanding or machining wood products can expose you to wood dust, a substance known to the State of California to cause cancer. Avoid inhaling wood dust or use a dust mask or other safeguards for personal protection.

For more information go to **www.P65Warnings.ca.gov/wood**.

Active Patents assigned to Wood-Mizer, LLC

Wood-Mizer, LLC has received patents that protect our inventions which are a result of a dedication to research, innovation, development, and design. Learn more at: woodmizer.com/patents

©2024 Wood-Mizer LLC

Printed in the United States of America, all rights reserved. No part of this manual may be reproduced in any form by any photographic, electronic, mechanical or other means or used in any information storage and retrieval system without written permission from

Wood-Mizer, LLC
8180 West 10th Street
Indianapolis, Indiana 46214

SECTION 1 ABOUT THIS MANUAL

SECTION 2 OPERATION

2.1 Starting The Engine 2-1

SECTION 3 MAINTENANCE

3.1 Safety 3-1
3.2 Cooling System 3-1
3.3 Air Cleaner 3-1
3.4 Fuel Filter 3-1
3.5 Battery 3-2
3.6 Alternator Belt 3-2
3.7 RPM Adjustments 3-2
3.8 Miscellaneous Maintenance 3-3

SECTION 4 REPLACEMENT PARTS

4.1 Service Fuel Tank (For Pre-2015 mills) 4-1
4.2 Engine Mount Assembly 4-1
4.3 Engine Assembly 4-2
4.4 Alternator Assembly 4-5
4.5 Engine Pulley Guards 4-1

SECTION 5 EFI DIAGNOSTIC INSTRUCTIONS

SECTION 1 ABOUT THIS MANUAL

This manual is provided as a supplement to the equipment manufacturer's manuals. This manual provides information specific to the use of this equipment on the Wood-Mizer® sawmill. Refer to the sawmill operator's manual and manufacturer's manual before attempting to operate this equipment.

NOTICE Read the sawmill operator's manual and engine manufacturer's manual for instructions and safety precautions before operating this equipment.

The information and instructions given in this manual do not amend or extend the limited warranties for the equipment given at the time of purchase.

For electric sawmill installation instructions and power requirements, [see Form 542](#).

SECTION 2 OPERATION

2.1 Starting The Engine

Engine Control Lights



Alternator Charge Indicator: Lights up if the alternator is not charging the battery.



Key Switch Indicator: Lights up when the key is in either the on or accessory (#1 or #3) position.

A diagnostic light is also provided to help troubleshoot the electronic fuel injection system. See [Appendix A](#) for details.

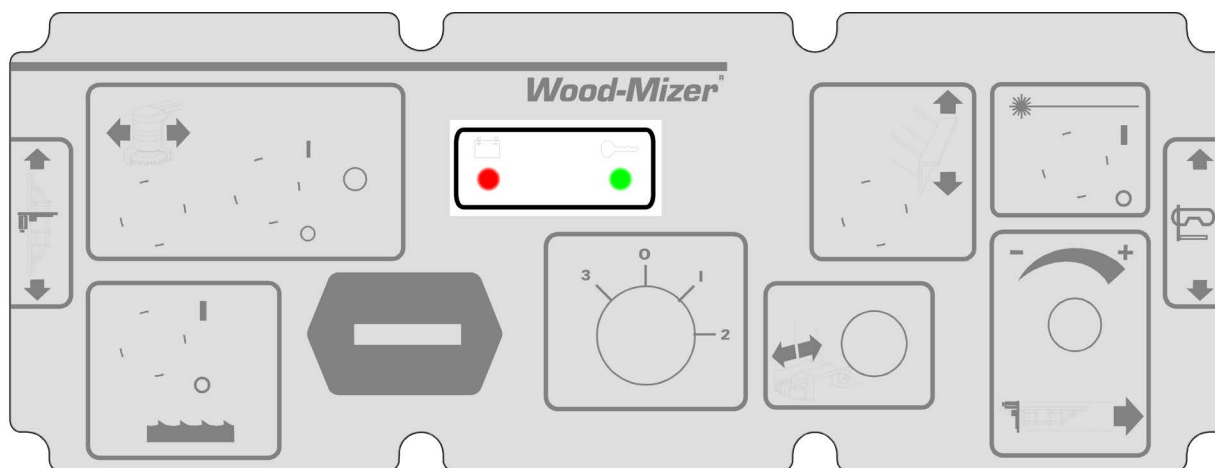

FIG. 2-1

ENGINE START



DANGER! Always be sure the blade is disengaged and all persons are out of the path of the blade before starting the engine. Failure to do so will result in serious injury.

DANGER! Operate your engine/machine only in well ventilated areas. The exhaust gases of your engine can cause nausea, delirium and potentially death unless adequate ventilation is present.

DANGER! Never operate an engine with a fuel or oil leak. The leaking fuel or oil could potentially come in contact with hot surfaces and ignite into flames.



WARNING! Be sure the power feed switch is in the neutral position before turning the key switch to the on (#1) or accessory (#3) position. This prevents accidental carriage movement, which may cause serious injury or death.

WARNING! Do not operate engine without proper and operational spark arrester/muffler. Sparks emitted from the engine exhaust could ignite surrounding materials, causing serious injury or death.



WARNING! EPA Compliant Gas Tanks Only: Always relieve all fuel pressure inside the tank prior to filling or connecting fuel fittings. Failure to do so may result in fuel spillage.



WARNING! EPA Compliant Gas Tanks Only: Disconnect the fuel tank when not in use or during transportation. Failure to do so may result in engine flooding or fuel spillage.

Turn the key switch to the start (#2) position and release.

For more information, see the engine manufacturer's operation manual.

NOTE: When the clutch handle is engaged, an accelerator pump is activated which supplies fuel to the engine carburetor. To avoid flooding the carburetor and possibly fouling the spark plugs, do not engage the clutch lever repeatedly without the engine running.

NOTE: If the engine dies after starting, check that the fuel pump is running. If the fuel pump is not running, check the relay inside the black control box on the side of the engine. Check the red wire connecting the relay to the fuel pump for voltage. Also check pin #30 & #86 for 12 volts. If voltage is found at the pins but not the red relay wire, replace the fuel pump relay. If no voltage is found at the pins, have the wiring harness checked by a qualified Kohler technician.

ENGINE SHUTOFF

Turn the key switch to the off (#0) position.

SECTION 3 MAINTENANCE

Refer to the manufacturer's manual for maintenance intervals and procedures unless otherwise instructed in this manual. Follow the manufacturer's recommendations for dusty conditions.

NOTICE Refer to the manufacturer's manual for complete maintenance instructions. This manual only provides information about additional procedures or procedures to be performed at different time intervals than found in the manufacturer's manuals



.WARNING! Clean sawdust from all guards, vents, control boxes, or any area where sawdust may gather **after every shift**. Failure to do so may result in fire, causing death or serious injury.



3.1 Safety

Use caution when performing maintenance or service to the engine.



DANGER! Always be aware of and take proper protective measures against rotating shafts, pulleys, fans, etc. Always stay a safe distance from rotating members and make sure that loose clothing or long hair does not engage rotating members resulting in possible injury.

DANGER! Engine components can become very hot during operation. Avoid contact with any part of a hot engine. The exhaust components of your engine are especially hot during and following operation. Contact with hot engine components can cause serious burns. Therefore, never touch or perform service functions on a hot engine. Allow the engine to cool sufficiently before beginning any service function.



WARNING! Remove the blade before performing any engine service. Failure to do so may result in serious injury.

WARNING! Always wear proper and necessary safety equipment when performing service functions. Proper safety equipment includes eye protection, breathing protection, hand protection and foot protection.

3.2 Cooling System

1. Wash the engine or brush off sawdust and debris every 50 hours of operation.
2. Clean the grass screen, cooling fins, and external surfaces.
3. Remove any dust, dirt or oil.
4. See engine manual for further instructions.

3.3 Air Cleaner

Replace the outer air cleaner cartridge and check the inner cartridge every 250 hours of operation or more often if operating the sawmill in dirty conditions or if engine performance indicates a new cartridge is necessary.



CAUTION! Do not clean elements with water or compressed air. Do not handle the inner element unless it is to be changed. Handle new elements carefully. Contact with the element could cause damage and prevent the filter from operating properly.

Replace the inner air cleaner cartridge every 1200 hours of operation or more often if operating the sawmill in dirty conditions.

3.4 Fuel Filter

Replace the fuel filter every 100 hours of operation or as required for engine performance.

3.5 Battery

Check the battery electrolyte level every 50 hours of operation. See manufacturer's manual for instructions.

! DANGER! Batteries expel explosive gases. Keep sparks, flames, burning cigarettes, or other ignition sources away at all times. Always wear safety goggles and a face shield when working near batteries. Failure to do so will cause serious injury.

! WARNING! Battery posts, terminals and related accessories contain lead and lead compounds, chemicals known to the State of California to cause cancer and reproductive harm. Wash hands after handling.

3.6 Alternator Belt

1. Adjust the alternator belt as needed.
2. Check the alternator belt for tension and wear when battery is not charging properly or when the alternator belt is squealing.
3. Tighten the belt by loosening the adjustment bolt and lock washer.
4. Pivot the alternator away from the motor until the belt has 3/16" (5 mm) deflection with a 5 lb. deflection force.
5. Retighten the adjustment bolt.

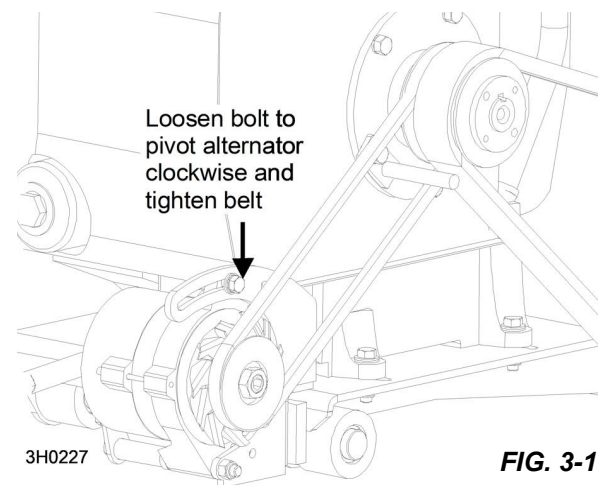

FIG. 3-1

3.7 RPM Adjustments

! WARNING! Remove the blade before performing any engine service. Failure to do so may result in serious injury.

1. Make sure belt and brake strap tensions are correct (See Sawmill Maintenance).
2. Check oil, fuel, and coolant levels.
3. Check the RPM with a tachometer every 200 hours of operation.

Engine	High End RPM	Low End RPM
G28	3750	1800

4. Ensure the throttle cable does not affect the engine RPM when the clutch handle is disengaged or the cable is not bent or kinked.

NOTE: It is important that the above components are aligned. Proper alignment allows any slack in the cable (when engine is idling) to slide down into the cable spring. This maintains free operation of the cable and prevents the cable from kinking.

5. Ensure the shoulder bolt does not rub against the crankcase vent tube.
6. Start the engine to measure the low-end RPM.
7. Refer to the engine manual to adjust the low-end RPM.
8. Engage the clutch handle to throttle the engine and measure the high-end RPM. The high-end RPM is factory-set at 3750.
9. Readjust the throttle cable if necessary to increase or reduce the high-end engine speed.

The throttle cable should be tensioned just enough so that the engine revs as soon as the clutch/brake handle is engaged.

NOTE: A properly adjusted throttle will extend the cable spring 1/4" to 3/8" (6.4 - 9.5 mm) when running and have a slight amount of slack in the cable when idling.

3.8 Miscellaneous Maintenance

Clean and inspect the spark arrester every 50 hours of operation.

Replace if damaged.

Review the manufacturer's engine manual for maintenance intervals.

SECTION 4 REPLACEMENT PARTS

4.1 Service Fuel Tank (For Pre-2015 mills)

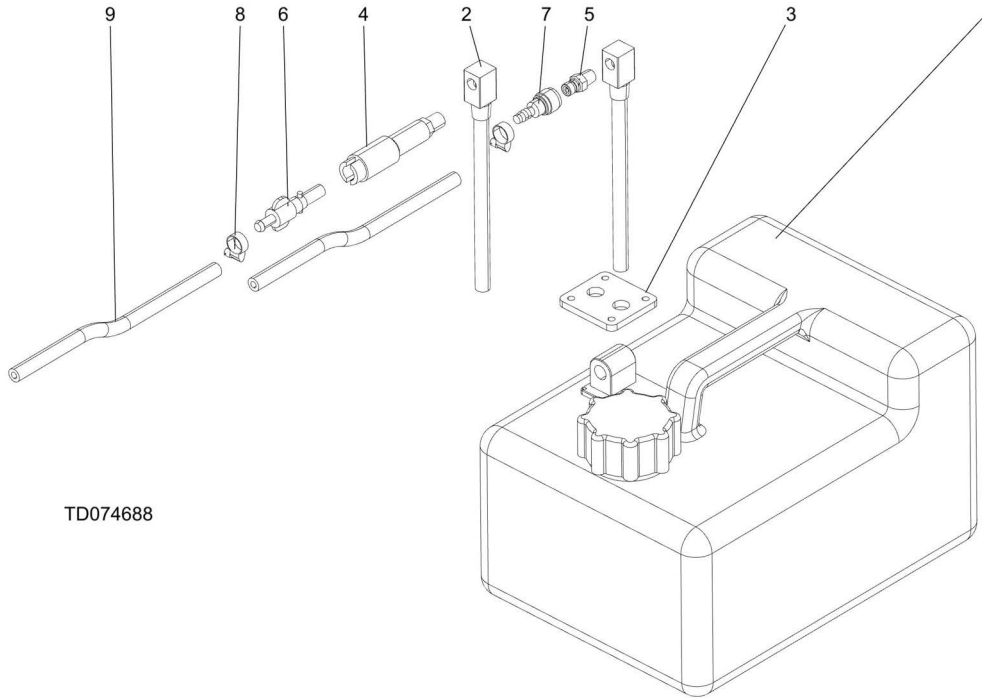

TD074688

REF	PART #	DESCRIPTION	COMMENTS	QTY.
	074688	Assy, 3 Gallon Gas Tank w/Return Service Original 036359 is not in compliance with EPA standards.	074688 replaces 036359. This assembly requires P11668 20" rubber straps (qty 2). Removed (1) 015583, F05011-140 & F05011-141 on 9/23 per ECN 39168	1
1	X200-1144	Can, 3 Gallon Gas		1
2	P12172	Fitting, 1/4NPTx9 Fuel Pick Up		2
3	076973	Plate, Fuel Return		1
4	P12175	Fitting, 1/4NPT Male-Female Discon	Replaced 015583 on 9/23 per ECN 39168	1
5	015583	Fitting, 1/4 NPT Male Quick Disconnect		1
6	P12176	Fitting, 1/4 Barb-Male Discon		1
7	015582	Fitting, Female Quick Disconnect Barb		1
8	P649	Clamp, 7/32 - 1/2 Hose		6
9	P642	Hose, 1/4" Id Fuel		13 Ft.

4.2 Engine Mount Assembly

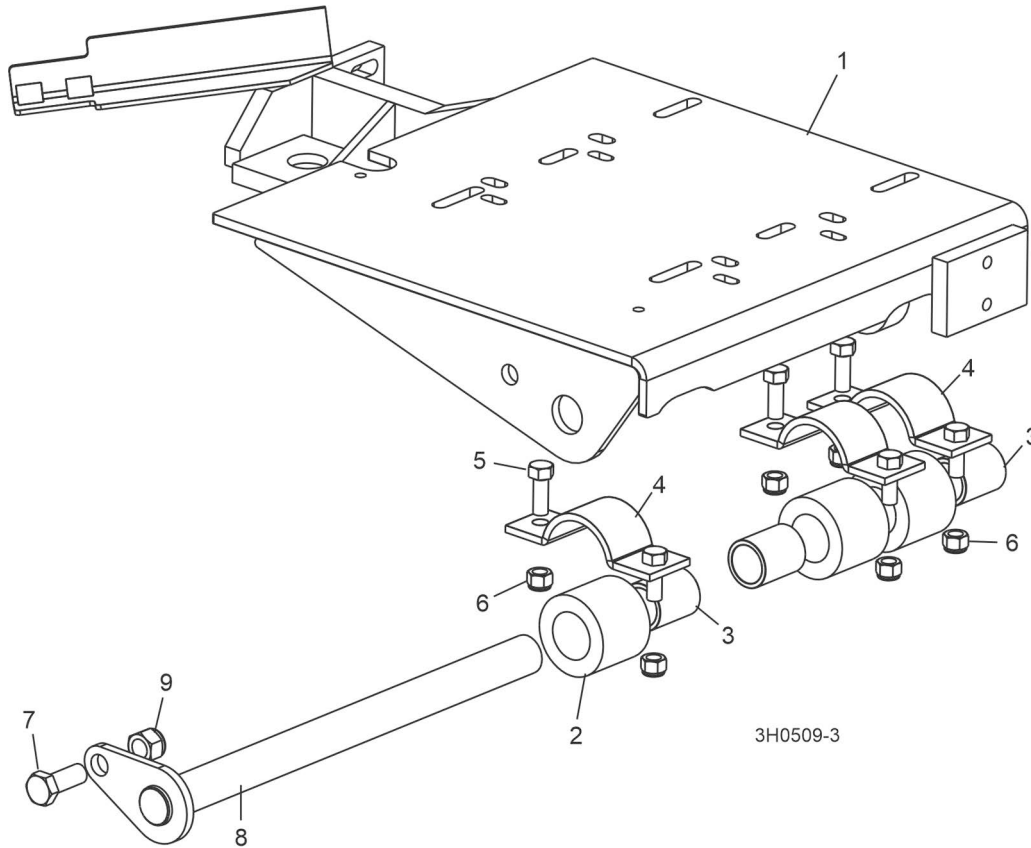

REF	PART #	DESCRIPTION	COMMENTS	QTY.
	016319	Mount Kit, Kohler Engine		1
1	014514	Mount Weldment, Kohler Engine	Available in assemblies only.	1
	016380	Bushing Assembly, Motor Mount		3
2	016378	Bushing, 2" OD x 2"	Available in assemblies only.	1
3	016379	Bearing, 1" x 1 1/4" x 2"	Available in assemblies only.	1
4	014540	Clamp Weldment , Motor Mount Pivot Bushing		3
5	F05007-7	Bolt, 3/8-16 x 1" Hex Head		3
6	F05010-10	Nut, 3/8-16 Hex Nylon Lock		6
7	F05008-37	Bolt, 1/2-13 x 1 1/4" Hex Head Grade 5		1
8	014154	Pin Weldment, Engine Mount Pivot		1
9	F05010-8	Nut, 1/2-13 Nylon Lock		1

4.3 Engine Assembly

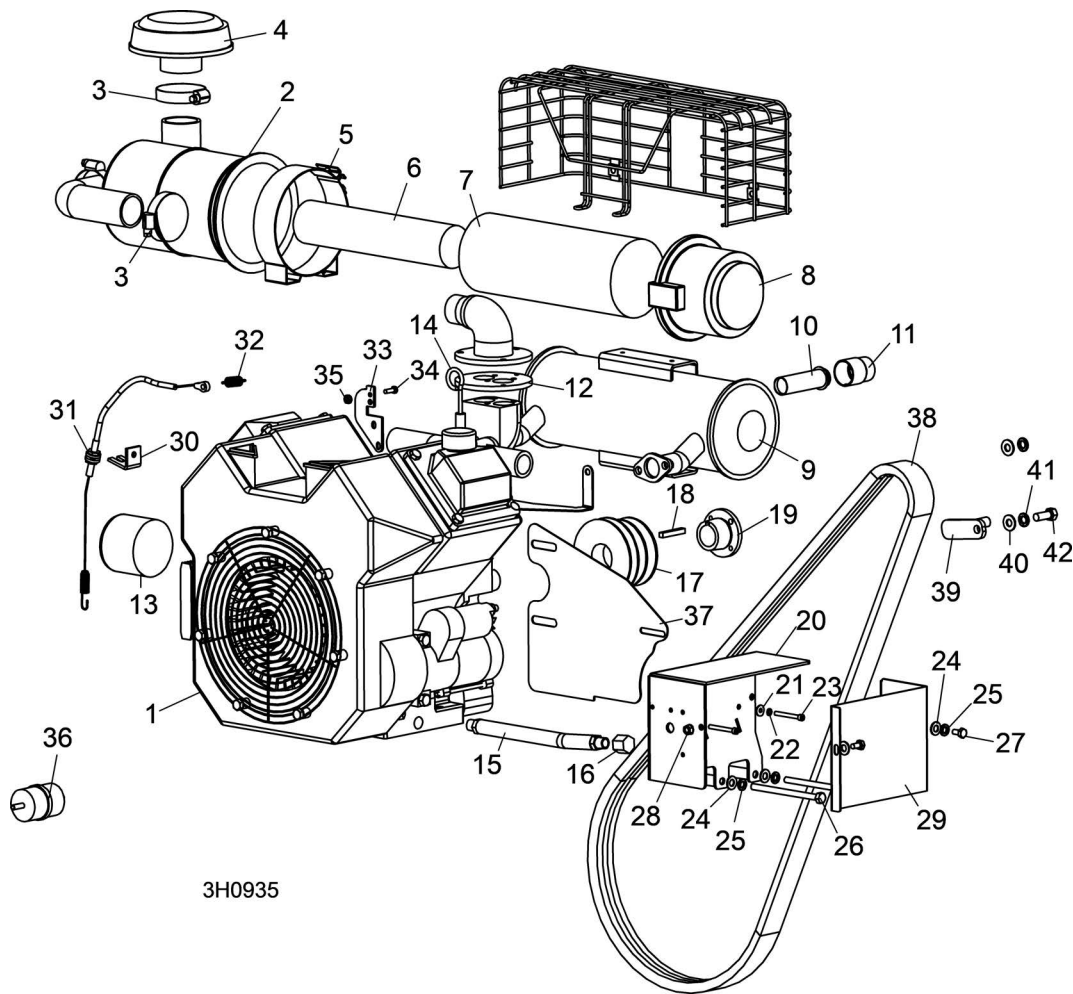

3H0935

REF	PART #	DESCRIPTION	COMMENTS	QTY.
	CEG28	COVER, G28 ENGINE		1
	036355	ENGINE ASSEMBLY, 28HP KOHLER		1
1	036351	Engine, 28Hp Kohler PH745-008	Available in assemblies only.	1
	016290	Gasket Kit, Kohler CH25 Head #24-841-03S		1
2	N/A	Cleaner Assembly, Kohler Air #		1
3	P09895	Clamp, 2 1/2" Hose		1
4	046556	Cap, Kohler Air Cleaner Rain #25-324-02-S		1
5	046550	Bracket, Kohler Air Cleaner Mount #25-126-02-S		1
6	046554	Filter, Kohler Air Cleaner #25-083-04-S		1
7	046553	Filter, Kohler Pre-Air Cleaner #25-083-01-S		1
8	046552	Cap, Kohler Air Cleaner Housing #25-096-06-S		1
	036507	Sensor, Kohler Oxygen #24-418-05S		1
	036508	Pump, Kohler Fuel #24-393-52S	Was Kohler #24-393-20S (discontinued by manufacturer).	1
	061184	Regulator, Fuel Kohler #2440316S CH745 Only		1
	061371	Starter, Kohler Engine KH# 25 098 21S		1
	052790	Relay, Kohler Fuel Pump #20-404-01		1

4 Replacement Parts

Engine Assembly

REF	PART #	DESCRIPTION	COMMENTS	QTY.
	036509	Filter, Kohler Fuel Micron #24-050-03S		1
9	052830	Muffler, Kohler #28-786-03	Use instead of 026452 incorrectly shown in older manuals.	1
	069546	Gasket, Kohler Muffler #24-041-49S	Kohler #24-041-49S replaces Kohler #24-024-49S.	2
	P12757	Plug, Kohler RC12YC Spark #12-132-02		1
10	N/A	Adapter, Kohler		1
11	016142	Arrestor, Kohler Spark #25-189-01		1
12	045982	Plate, Kohler Intake Manifold		1
13	014717	Filter, Kohler Oil #52-050-02		1
14	P07557	Dipstick, Kohler #24-038-10-S		1
15	P10082	Hose, 7" Oil Drain		1
16	P04332	Cap, Oil Drain 3/8" Pipe		1
	L04869-1	Oil, 10W30 Type CD	Available in assemblies only.	.5 Gal
17	S10435	Pulley, 3-Groove Motor		1
18	S04124	Key, 1/4" x 1/4" x 1 11/16"		1
19	P04306	Bushing, 1 1/8" Split Taper		1
20	046563	Box Weldment, Kohler ECU		1
	061086	Module, Engine Control ECU (G28) #25-584-58S		1
21	F05011-18	Washer, #10 SAE Flat		2
22	F05011-20	Washer, #10 Split Lock		2
23	F05004-192	Bolt, #10-24 x 1 3/4" Socket Head		2
24	F05011-17	Washer, 5/16" SAE Flat		4
25	F05011-13	Washer, 5/16" Split Lock		3
26	F05004-210	Bolt, M8 x 125 x 120mm Hex Head Full Thread		2
27	F05005-15	Bolt, 1/4-20 x 1/2" Hex Head		2
28	F05010-9	Nut, 1/4-20 Hex Self-Locking		1
29	045824	Cover, Kohler ECU Box		1
	051442	Connector Assembly, G28 ECU Diagnostic Light		1
	E20482	Light, Red 12V .187" Tabs		1
	051443	Wire Assembly, G28 Fuel Pump Ground		1
	015426	Diode Assembly, Solenoid Coil Chassis	Diode Assembly 015426 added to protect fuel pump circuit (LT30 Rev. J7.00, LT40 Rev. J8.00, LT30HD Rev. J8.00 and LT40HD Rev. J9.00).	1
30	S12312	Bracket, Throttle Mount		1
31	P12313	Cable Assembly, 18" Throttle		1
32	015952	Spring, 1/2" x .08" x 1 3/8" Extension		1
33	015964	Bracket, G25/28 Throttle		1
34	F05004-18	Screw, #10-24 x 5/8" Indented Hex Head		1
35	F05010-14	Nut, #10-24 Hex Self-Locking		1
36	P12758	FILTER, KOHLER FUEL #24-050-13	9-12 micron fuel filter (Kohler #24-050-13) replaces 8-10 micron fuel filter (Kohler #240-050-10) originally supplied.	1
37	015900	PLATE, G25 REAR ENGINE GUARD		1
38	036163	BELT, 2BXF71 DRIVE		1
39	015963	BRACKET WELDMENT, DRIVE BELT SUPPORT PAINTED		1
40	F05011-3	WASHER, 3/8" SAE FLAT		2

REF	PART #	DESCRIPTION	COMMENTS	QTY.
41	F05011-4	WASHER, 3/8" SPLIT LOCK		2
42	F05007-7	BOLT, 3/8-16 X 1" HEX HEAD		1

4.4 Alternator Assembly

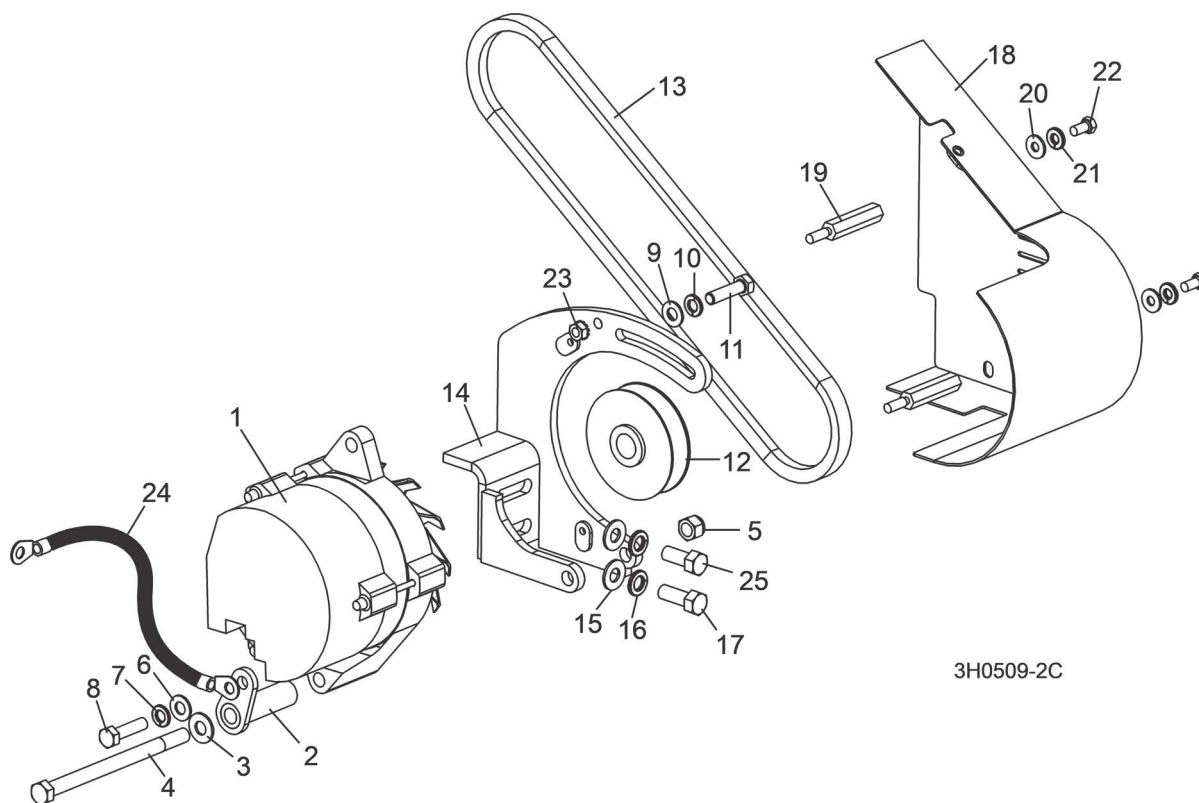

3H0509-2C

REF	PART #	DESCRIPTION	COMMENTS	QTY.
1	050287-1	Alternator, 12V 105A	Alternator 050287-1 replaced 050287 as of 4/2021, per ECN 37893.	1
2	W12761	Brace, Alternator		1
3	F05011-3	Washer, 3/8" SAE Flat		1
4	F05007-34	Bolt, 3/8-16 x 5 1/2" Hex Head Full Thread		1
5	F05010-10	Nut, 3/8-16 Hex Nylon Lock		1
6	F05011-17	Washer, 5/16" SAE Flat		1
7	F05011-13	Washer, 5/16" Split Lock		1
8	F05004-40	Bolt, M8 X 1.25" X 1" Hex Head Full Thread		1
9	F05011-17	Washer, 5/16" SAE Flat		1
10	F05011-13	Washer, 5/16" Split Lock		1
11	F05004-40	Bolt, M8 X 1.25" X 1" Hex Head Full Thread		1
12	P03806	Pulley, Alternator		1
13	P11542	Belt, A33 Alternator		1
	015969	Wire Assembly, 61/105 Amp Alternator Plug		1
	024308	Wire Assembly, Alternator/Starter		1
14	014509	Bracket, Alternator Mount		1
15	F05011-3	Washer, 3/8" SAE Flat		2
16	F05011-4	Washer, 3/8" Split Lock		2
17	F05007-7	Bolt, 3/8-16 x 1" Hex Head		1
18	014499	Guard, Alternator Belt		1
19	015957	Standoff, 1/4-20 x 1 7/8"		2
20	F05011-11	Washer, 1/4" SAE Flat		2
21	F05011-14	Washer, 1/4" Split Lock		2

REF	PART #	DESCRIPTION	COMMENTS	QTY.
22	F05005-15	Bolt, 1/4-20 x 1/2" Hex Head		2
23	F05010-9	Nut, 1/4-20 Self-Locking Hex		1
24	017770	Wire Assembly, Ground Jumper		1
25	F05007-27	Bolt, 3/8-16 x 3/4" Hex Head		1

4.5 Engine Pulley Guards

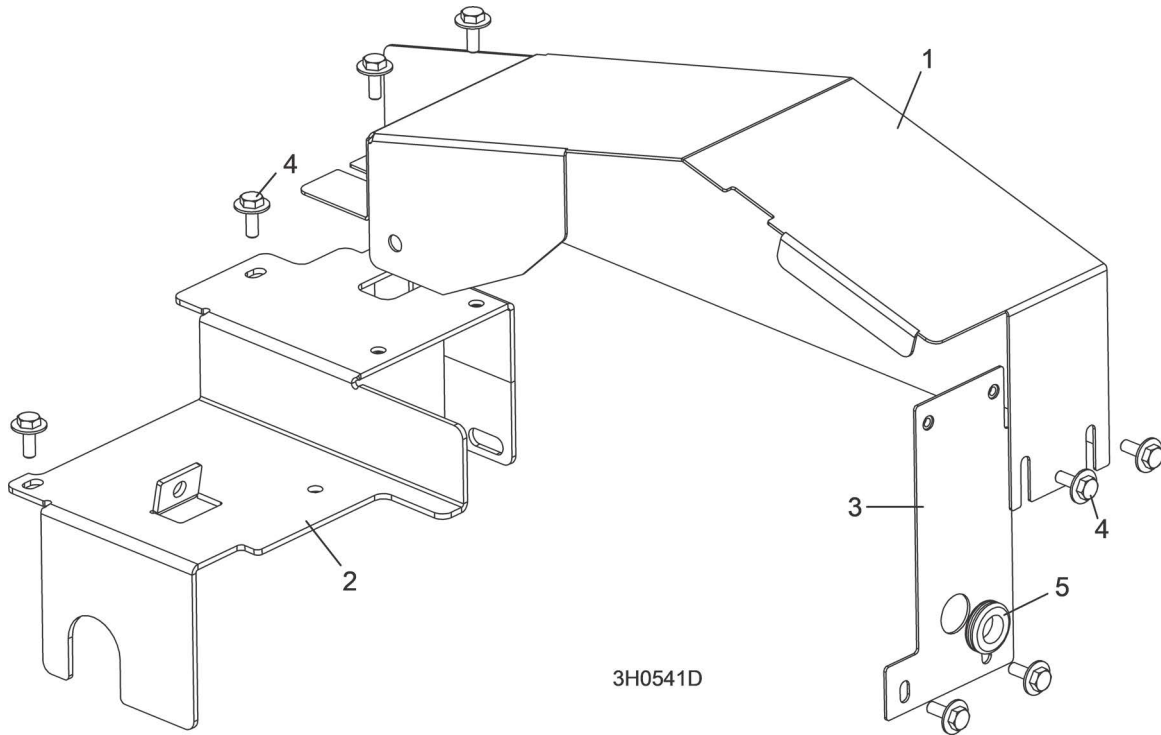

REF	PART #	DESCRIPTION	COMMENTS	QTY.
1	015960	Guard Weldment, Kohler Engine Pulley		1
2	015962	Guard, Kohler Side Engine Pulley		1
3	015961	Guard, Kohler Bottom Engine Pulley		1
4	F05005-134	Bolt, 1/4-20 x 3/4" Hex Head w/Conical Washer		8
5	P11764	Grommet, 5/8" ID Rubber		1

Section 5B EFI Fuel System

Excerpt from Kohler service manual Wood-Mizer #3H0927B-1

Fuel System



WARNING: Fuel System Under Pressure!

The fuel system operates under high pressure. System pressure must be relieved through the test valve in the fuel rail prior to servicing or removing any fuel system components. Do not smoke or work near heaters or other fire hazards. Have a fire extinguisher handy and work only in a well-ventilated area.

The function of the fuel system is to provide sufficient delivery of fuel at the system operating pressure of 39 psi \pm 3. If an engine starts hard, or turns over but will not start, it may indicate a problem with the EFI fuel system. A quick test will verify if the system is operating.

1. Disconnect and ground the spark plug leads.
2. Complete all safety interlock requirements and crank the engine for approximately 3 seconds.
3. Remove the spark plugs and check for fuel at the tips.
 - a. If there is fuel at the tips of the spark plugs, the fuel pump and injectors are operating.
 - b. If there is no fuel at the tips of the spark plugs, check the following:
 1. Make sure the fuel tank contains clean, fresh, proper fuel.
 2. Make sure that vent in fuel tank is open.
 3. Make sure fuel tank valve (if so equipped) is fully opened.
 4. Make sure battery is supplying proper voltage.
 5. Check that the fuses are good, and that all electrical and fuel line connections are good.
 6. Test fuel pump and relay operation as described earlier under "Fuel Pump – Service."

Fault Codes

The ECU continuously monitors engine operation against preset performance limits. If the operation is outside the limits, the ECU activates the MIL and stores a diagnostic code in its fault memory. If the component or system returns to proper function, the ECU will eventually self-clear the fault code and turn off the MIL. If the MIL stays illuminated, it warns the customer that dealer service is required. Upon receipt, the dealer technician can access the fault code(s) to help determine what portion of the system is malfunctioning. The 2-digit blink codes available based upon the style of ECU are listed on pages 5B.35-5B.36.

The codes are accessed through the key switch and displayed as blinks or flashes of the MIL. Access the codes as follows:

1. Start with the key switch off.
2. Turn the key switch on-off-on-off-on, leaving it on in the third sequence. The time between sequences must be less than 2.5 seconds.
3. Any stored fault codes will then be displayed as a series of MIL blinks (from 2 to 6) representing the first digit, followed by a pause, and another series of blinks (from 1 to 6) for the second digit (see Figure 5B-43).
 - a. It's a good idea to write down the codes as they appear, as they may not be in numerical sequence.
 - b. Code 61 will always be the last code displayed, indicating the end of code transmission. If code 61 appears immediately, no other fault codes are present.

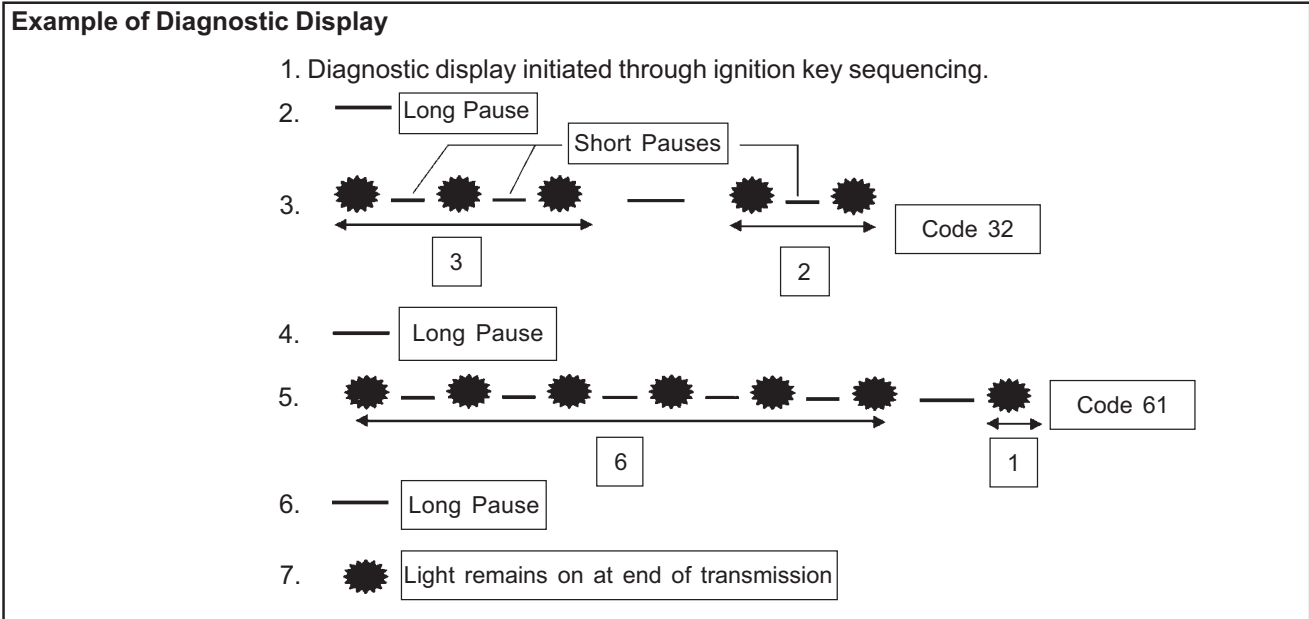

Figure 5B-43.

After the problem has been corrected, the fault codes may be cleared as follows.

1. Disconnect the negative (-) battery cable from battery terminal, or remove the main fuse for the ECU for approximately 1 minute.
Excerpt from Kohler service manual Wood-Mizer #3H0927B-1
2. Reconnect the cable and tighten securely, or reinstall the main fuse. Start the engine and allow it to run for several minutes. The MIL should remain off if the problem was corrected, and the fault codes should not reappear (codes 31, 32, 33, and 34 may require 10-15 minutes of running to reappear).

The following chart lists the fault codes, what they correspond to, and what the visual indications will be. Following the chart is a list of the individual codes with an explanation of what triggers them, what symptoms might be expected, and the probable causes.

Diagnostic Code Summary

Blink Code	OBID2 P-Code Applicable to: "32 Pin" (MSE 1.1) ECU/System Only	Connection or Failure Description	"35 Pin" (MA 1.7) Metal-Cased ECU/System	"24 Pin" (MSE 1.0) Plastic-Cased ECU/System	"32 Pin" (MSE 1.1) Plastic-Cased ECU/System	Note
-	-	No RPM Signal	Y	Y	Y	
21	P0335	Loss of Synchronization	Y	Y	Y	
22	P0120	TPS - Signal Implausible	N	N	N	2
22	P0122	TPS - Open or Short Circuit to Ground	Y	Y	Y	
22	P0123	TPS - Short Circuit to Battery	Y	Y	Y	
23	P0601	Defective ECU	Y	Y	Y	
24		Engine Speed Sensor	Y	Y	Y	9
31	P0174	System too Lean	Y	Y	Y	6

cont. on next page

Section 5B EFI Fuel System

Excerpt from Kohler service manual Wood-Mizer #3H0927B-3

Blink Code	OBD2 P-Code Applicable to: "32 Pin" (MSE 1.1) ECU/System Only	Connection or Failure Description	"35 Pin" (MA 1.7) Metal-Cased ECU/System	"24 Pin" (MSE 1.0) Plastic-Cased ECU/System	"32 Pin" (MSE 1.1) Plastic-Cased ECU/System	Note
31	P0132	O ₂ Sensor Circuit: Shorted to Battery	Y	N	Y	3
32	P0134	O ₂ Sensor Circuit: No Activity Detected	N	N	N	8
33	P0175	System too Rich	Y	Y	Y	7,8
33	P0020	O ₂ Sensor Control at Upper Limit	Y	Y	Y	8
34	P0171	Maximum Adaption Limit Reached	Y	Y	Y	8
34	P0172	Minimum Adaption Limit Reached	Y	Y	Y	8
42	P0117	Temperature Sensor Circuit: Shorted to Ground	Y	Y	Y	
42	P0118	Temperature Sensor Circuit: Open Circuit or Short to Battery	Y	Y	Y	
43	N/A	Failure Completing Autolearn - TPS Offset below minimum allowable limit	N/A	N/A	Y	
44	N/A	Failure Completing Autolearn - TPS offset above maximum allowable limit	N/A	N/A	Y	
51	P1260	Injector 1 - Open Circuit	N/A	N/A	Y	
51	P0261	Injector 1 - Short Circuit to Ground	N/A	N/A	Y	
51	P0262	Injector 1 - Short Circuit to Battery	N/A	N/A	Y	
52	P1263	Injector 2 - Open Circuit	N/A	N/A	Y	
52	P0264	Injector 2 - Short Circuit to Ground	N/A	N/A	Y	
52	P0265	Injector 2 - Short Circuit to Battery	N/A	N/A	Y	
55	P1651	Diagnostic Lamp - Open Circuit	N/A	N/A	Y	
55	P1652	Diagnostic Lamp - Short Circuit to Ground	N/A	N/A	Y	
55	P1653	Diagnostic Lamp - Short Circuit to Battery	N/A	N/A	Y	
56	P1231	Pump Relay - Open Circuit	N/A	N/A	Y	
56	P1232	Pump Relay - Short Circuit to Ground	N/A	N/A	Y	
56	P1233	Pump Relay - Short Circuit to Battery	N/A	N/A	Y	
61		End of Code Transmission	Y	Y	Y	

Note:

1. Idle Switch not used.
2. Diagnostic of "TPS - Signal Implausible" is disabled in code.
3. "O₂ Sensor Short to Battery" diagnostic detection is disabled with SAS fuel-cutoff calibrated out.
4. Air Temperature Sensor not used.
5. "Temperature Sensor Signal Implausible": diagnostic detection is calibrated out, with TPLAUS set to -50°C.
6. System too Lean used to be "O₂ Sensor - Short to Ground (P0131)."
7. "System too Rich" used to be "O₂ Sensor Control at Lower Limit (P0019)."
8. Obtainable only with ECU 24 584 28-S or later.
9. Will not blink out.

Code: 21
Source: Engine Speed Sensor
Explanation: ECU receiving inconsistent tooth count signals from speed sensor.
Expected Engine Response: Possible misfire as ECU attempts to resynchronize, during which time fuel and spark calculations are not made.

Possible Causes:

1. Engine Speed Sensor Related
 - a. Sensor connector or wiring.
 - b. Sensor loose or incorrect air gap.
 - c. Flywheel key sheared.

2. Speed Sensor Ring Gear Related
 - a. Damaged teeth.
 - b. Varying gap (gear loose/out of alignment).

3. Engine Wiring Harness Related
"35 Pin" (MA 1.7) Metal-Cased ECU:
 - a. Pin circuits 3 and/or 21 wiring or connectors.
 - b. Shielding for pin circuits 3 and/or 21 damaged or not properly grounded.
 - c. Poor or improper grounds in system (battery, ECU, oxygen sensor, shielding, fuel pump, ignition output).
 - d. Pin circuits 3 and/or 21 routed near noisy electrical signals (coils, spark plug lead, plug connector).

3. Engine Wiring Harness Related
"24 Pin" (MSE 1.0) Plastic-Cased ECU:
 - a. Pin circuits 9 and/or 10 wiring or connectors.
 - b. Shielding for pin circuits 9 and/or 10 damaged or not properly grounded.
 - c. Poor or improper grounds in system (battery, ECU oxygen sensor, shielding, fuel pump, ignition output).
 - d. Pin circuits 9 and/or 10 routed near noisy electrical signals (coils, spark plug lead, plug connector).

3. Engine Wiring Harness Related
"32 Pin" (MSE 1.1) Plastic-Cased ECU:
 - a. Pin circuits 9 and/or 10 wiring or connectors.
 - b. Shielding for pin circuits 9 and/or 10 damaged or not properly grounded.
 - c. Poor or improper grounds in system (battery, ECU, oxygen sensor, shielding, fuel pump, ignition output).
 - d. Pin circuits 9 and/or 10 routed near noisy electrical signals (coils, spark plug lead, plug connector).

4. ECU/Harness Related
 - a. ECU-to-harness connection problem.

5. Ignition System Related
 - a. Non-resistor spark plug(s) used.

Code: 22
Source: Throttle Position Sensor (TPS)
Explanation: Unrecognizable signal is being sent from sensor (too high, too low, inconsistent).

Expected Engine

Response: A "limp-home" operating mode occurs, with an overall decrease in operating performance and efficiency. Fuel delivery is based upon the oxygen sensor and five mapped values only. Rich running (black smoke) will occur until "closed loop" operation is initiated. A stumble or misfire on hard acceleration and/or erratic operation may be exhibited.

Possible Causes:

1. TPS Sensor Related
 - a. Sensor connector or wiring.
 - b. Sensor output affected or disrupted by dirt, grease, oil, wear, or breather tube position (must be to side opposite the TPS).
 - c. Sensor loose on throttle body manifold.

2. Throttle Body Related
 - a. Throttle shaft or bearings worn/damaged.

3. Engine Wiring Harness Related
"35 Pin" (MA 1.7) Metal-Cased ECU:
 - a. Pin circuits 12, 25 and/or 27 damaged (wiring or connectors).
 - b. Pin circuits 12, 25 and/or 27 routed near noisy electrical signal (coils, alternator).
 - c. Intermittent 5 volt source from ECU (pin circuit 25).

3. Engine Wiring Harness Related
"24 Pin" (MSE 1.0) Plastic-Cased ECU:
 - a. Pin circuits 4, 8, and/or 14 damaged (wiring, connectors).
 - b. Pin circuits 4, 8, and/or 14 routed near noisy electrical signal (coils, alternator).
 - c. Intermittent 5 volt source from ECU (pin circuit 14).

Section 5B

EFI Fuel System

Excerpt from Kohler service manual Wood-Mizer #3H0927B-5

3. Engine Wiring Harness Related
"32 Pin" (MSE 1.1) Plastic-Cased ECU:
 - a. Pin circuits 4, 8, and/or 18 damaged (wiring, connectors).
 - b. Pin circuits 4, 8, and/or 18 routed near noisy electrical signal (coils, alternator).
 - c. Intermittent 5 volt source from ECU (pin circuit 18).
4. ECU/Harness Related
 - a. ECU-to-harness connection problem.

Code: 23
Source: ECU
Explanation: ECU is unable to recognize or process signals from its memory.

Expected Engine

Response: Engine will not run.

Possible Causes:

1. ECU (internal memory problem).
 - a. Diagnosable only through the elimination of all other system/component faults.

Code: 24 (Will not blink out)
Source: Engine Speed Sensor
Explanation: No tooth signal from speed sensor. MIL light will not go out when cranking.

Expected Engine

Response: None-engine will not start or run as ECU is unable to estimate speed.

Possible Causes:

1. Engine Speed Sensor Related
 - a. Sensor connector or wiring.
 - b. Sensor loose or air gap incorrect.
2. Speed Sensor Wheel Related
 - a. Damaged teeth.
 - b. Gap section not registering.
3. Engine Wiring Harness Related
 - a. Pin circuit wiring or connectors.
Pin(s) 3 and/or 21 for **"35 Pin" (MA 1.7) Metal-Cased ECU.**
Pin(s) 9 and/or 10 for **"24 Pin" (MSE 1.0) Plastic-Cased ECU.**
Pin(s) 9 and/or 10 for **"32 Pin" (MSE 1.1) Plastic-Cased ECU.**
4. ECU/Harness Related
 - a. ECU-to-harness connection problem.

Code: 31
Source: Fuel Mixture or Oxygen Sensor
Explanation: "System too lean." Oxygen sensor not sending expected voltage to ECU.

Expected Engine

Response: System operates under "open loop" control only. Until fault is detected and registered by ECU, engine will run rich if oxygen sensor is shorted to ground or lean if it is shorted to battery voltage. After fault is detected, performance can vary, depending on cause. If performance is pretty good, the problem is probably with the oxygen sensor, wiring, or connectors. If the engine is still running rich (laboring, short on power) or lean (popping or misfiring), the fuel mixture is suspect, probably incorrect TPS initialization or low fuel pressure.

Possible Causes:

1. TPS Initialization Incorrect
 - a. Lean condition (check oxygen sensor signal with VOA and see Oxygen Sensor section).
2. Engine Wiring Harness Related
 - a. Pin circuit wiring or connectors.
Pin 10 for **"35 Pin" (MA 1.7) Metal-Cased ECU.**
Pin 11 for **"24 Pin" (MSE 1.0) Plastic-Cased ECU.**
Pin 20 for **"32 Pin" (MSE 1.1) Plastic-Cased ECU.**
3. Low Fuel Pressure
4. Oxygen Sensor Related
 - a. Sensor connector or wiring problem.
 - b. Exhaust leak.
 - c. Poor ground path to engine (sensor is case grounded).
5. Poor system ground from ECU to engine, causing rich running while indicating lean.

Code: 32
Source: Oxygen Sensor
Explanation: No change in the sensor output signal.
Expected Engine Response: "Open loop" operation only, may cause a drop in system performance and fuel efficiency.

Possible Causes:

1. Engine Wiring Harness Related
 - a. Pin circuit wiring or connectors.
Pin 10 for "35 Pin" (MA 1.7) Metal-Cased ECU.
Pin 11 for "24 Pin" (MSE 1.0) Plastic-Cased ECU.
Pin 20 for "32 Pin" (MSE 1.1) Plastic-Cased ECU.
2. Oxygen Sensor Related
 - a. Sensor connector or wiring problem.
 - b. Sensor contaminated or damaged.
 - c. Sensor below the minimum operating temperature (375°C, 709°F).
 - d. Poor ground path from sensor to engine (sensor grounds through shell, see Oxygen Sensor section).

Code: 33
Source: Oxygen Sensor/Fuel System
Explanation: "System too rich." Temporary fuel adaptation control is at the upper limit.
Expected Engine Response: Erratic performance. Will run rich (smoke).

Possible Causes:

1. Fuel Supply Related (nothing lean – only rich)
 - a. Restricted return line causing excessive fuel pressure.
 - b. Fuel inlet screen plugged (in-tank fuel pump only).
 - c. Incorrect fuel pressure at fuel rail.
2. Oxygen Sensor Related
 - a. Sensor connector or wiring problem.
 - b. Sensor contaminated or damaged.
 - c. Exhaust leak.
 - d. Poor ground path.
 - e. Pin circuit wiring or connectors.
Pin 10 for "35 Pin" (MA 1.7) Metal-Cased ECU.
Pin 11 for "24 Pin" (MSE 1.0) Plastic-Cased ECU.

Pin 20 for "32 Pin" (MSE 1.1) Plastic-Cased ECU.

3. TPS Sensor Related
 - a. Throttle plate position incorrectly set or registered during "Initialization."
 - b. TPS problem or malfunction.
4. Engine Wiring Harness Related
 - a. Difference in voltage between sensed voltage (pin circuit 17 for metal-cased ECU, pin circuit 2 for plastic-cased ECU) and actual injector voltage (circuit 45/45A).
5. Systems Related
 - a. Ignition (spark plug, plug wire, ignition coil).
 - b. Fuel (fuel type/quality, injector, fuel pump, fuel pressure).
 - c. Combustion air (air cleaner dirty/restricted, intake leak, throttle bores).
 - d. Base engine problem (rings, valves).
 - e. Exhaust system leak.
 - f. Fuel in the crankcase oil.
 - g. Blocked or restricted fuel return circuit to tank.
6. ECU/Harness Related
 - a. ECU-to-harness connection problem.

Code: 34
Source: Oxygen Sensor/Fuel System Components
Explanation: Long term fuel adaptation control is at the upper or lower limit.
Expected Engine Response: System operates "closed loop." No appreciable performance loss as long as the temporary adaptation can provide sufficient compensation.

Possible Causes:

1. Oxygen Sensor Related
 - a. Sensor connector or wiring problem.
 - b. Sensor contaminated or damaged.
 - c. Exhaust leak.
 - d. Poor ground path.
 - e. Pin circuit wiring or connectors.
Pin 10 for "35 Pin" (MA 1.7) Metal-Cased ECU.
Pin 11 for "24 Pin" (MSE 1.0) Plastic-Cased ECU.
Pin 20 for "32 Pin" (MSE 1.1) Plastic-Cased ECU.

Section 5B

EFI Fuel System

Excerpt from Kohler service manual Wood-Mizer #3H0927B-7

2. TPS Sensor Related
 - a. Throttle plate position incorrect during "Initialization" procedure.
 - b. TPS problem or malfunction.
3. Engine Wiring Harness Related
 - a. Difference in voltage between sensed voltage (pin circuit 17 for metal-cased ECU, pin circuit 2 for plastic-cased ECU) and actual injector voltage (circuit 45/45A).
 - b. Problem in wiring harness.
 - c. ECU-to-harness connection problem.
4. Systems Related
 - a. Ignition (spark plug, plug wire, ignition coil).
 - b. Fuel (fuel type/quality, injector, fuel pressure, fuel pump).
 - c. Combustion air (air cleaner dirty/restricted, intake leak, throttle bores).
 - d. Base engine problem (rings, valves).
 - e. Exhaust system leak (muffler, flange, oxygen sensor mounting boss, etc.).
 - f. Fuel in the crankcase oil.
 - g. Altitude.
 - h. Blocked or restricted fuel return circuit to tank.

Code: 42
Source: Engine (Oil) Temperature Sensor
Explanation: Not sending proper signal to ECU.
Expected Engine Response: Engine may be hard to start because ECU can't determine correct fuel mixture.

Possible Causes:

1. Temperature Sensor Related
 - a. Sensor wiring or connection.
2. Engine Wiring Harness Related
"35 Pin" (MA 1.7) Metal-Cased ECU:
 - a. Pin circuits 14 and/or 27A damaged (wires, connectors) or routed near noisy signal (coils, alternator, etc.).
 - b. ECU-to-harness connection problem.
2. Engine Wiring Harness Related
"24 Pin" (MSE 1.0) Plastic-Cased ECU:
 - a. Pin circuits 4, 6 and/or 4A damaged (wires, connectors) or routed near noisy signal (coils, alternator, etc.).
 - b. ECU-to-harness connection problem.

2. Engine Wiring Harness Related
"32 Pin" (MSE 1.1) Plastic-Cased ECU:
 - a. Pin circuits 4, 6 and/or (4A) damaged (wires, connectors) or routed near noisy signal (coils, alternator, etc.).
 - b. ECU-to-harness connection problem.
3. System Related
 - a. Engine is operating above the 176°C (350°F) temperature sensor limit.

Code: 43 and 44 **"32 Pin" (MSE 1.1) Plastic-Cased ECU only.**

Source: TPS "Auto-Learn" initialization function failed, throttle angle out of learning range.

Explanation: While performing the TPS "Auto-Learn" function, the measured throttle angle was not within acceptable limits.

Expected Engine

Response: MIL illuminated. Engine will continue to run but not properly. Upon restart TPS Auto-Learn function will run again unless voltage to ECU disconnected to clear memory.

Possible Causes:

1. TPS Related
 - a. TPS rotated on throttle shaft assembly beyond allowable range.
 - b. TPS bad.
2. Engine Wiring Harness Related
 - a. Broken or shorted wire in harness. ECU pin 18 to TPS pin 1. ECU pin 4 to TPS pin 2. ECU pin 8 to TPS pin 3.
3. Throttle Body Related
 - a. Throttle shaft inside TPS worn, broken, or damaged.
 - b. Throttle plate loose or misaligned.
 - c. Throttle plate bent or damaged allowing extra airflow past, or restricting movement.
4. ECU Related
 - a. Circuit providing voltage or ground to TPS damaged.
 - b. TPS signal input circuit damaged.

5. Oxygen Sensor/Harness Related
 - a. Oxygen sensor bad.
 - b. Wiring problem to oxygen sensor.
 - c. Muffler leak (causing O₂ sensor to falsely indicate a lean condition).
 - d. Bad ground between ECU and engine.

Code: **51** **"32 Pin" (MSE 1.1) Plastic-Cased ECU only.**

Source: Injector #1 circuit open, shorted to ground, or shorted to battery.

Explanation: Injector #1 is not functioning because the circuit is open, shorted to ground, or shorted to battery.

Expected Engine

Response: Engine will run very poorly with only one cylinder functioning.

Possible Causes:

1. Injector Related
 - a. Injector coil shorted or opened.
2. Engine Wiring Harness Related
 - a. Broken or shorted wire in harness. ECU pin 14 to injector pin 2. ECU pin 28 to fuel pump relay pin 86. Note: after key-off then key-on code 56 would be set also. Fuel pump relay pin 87 to injector pin 1.
 - b. Open main fuse F1.
3. Fuel Pump Relay Related
 - a. Bad fuel pump relay. Primary side functional but pin 30 to pin 87 remains open. Primary side pin 85 to pin 86 is either open, or shorted during engine operation. Note: after key-off then key-on code 56 would be set also.
4. ECU Related
 - a. Circuit controlling injector #1 damaged.
 - b. Circuit controlling fuel pump relay damaged.

Code: **52** **"32 Pin" (MSE 1.1) Plastic-Cased ECU only.**

Source: Injector #2 circuit open, shorted to ground, or shorted to battery.

Explanation: Injector #2 is not functioning because the circuit is open, shorted to ground, or shorted to battery.

Expected Engine

Response: Engine will run very poorly with only one cylinder functioning.

Possible Causes:

1. Injector Related
 - a. Injector coil shorted or opened.
2. Engine Wiring Harness Related
 - a. Broken or shorted wire in harness. ECU pin 15 to injector pin 2. ECU pin 28 to fuel pump relay pin 86. Note: after key-off then key-on code 56 would be set also. Fuel pump relay pin 87 to injector pin 1.
 - b. Opened main fuse F1.
3. Fuel Pump Relay Related
 - a. Bad fuel pump relay. Primary side functional, but pin 30 to pin 87 remains open. Primary side pin 85 to pin 86 is open or shorted during engine operation. Note: after key-off then key-on code 56 would be set also.
4. ECU Related
 - a. Circuit controlling injector #2 damaged.
 - b. Circuit controlling fuel pump relay damaged.

Code: **55** **"32 Pin" (MSE 1.1) Plastic-Cased ECU only.**

Source: MIL (Diagnostic lamp) circuit open, shorted to ground, or shorted to battery.

Explanation: MIL is not functioning because the circuit is open, shorted to ground, or shorted to battery.

Expected Engine

Response: Engine will run normally if no other errors are present.

Possible Causes:

1. MIL (diagnostic lamp) Related
 - a. MIL element opened or element shorted to ground.
 - b. Lamp missing.
2. Engine Wiring Harness Related
 - a. Broken or shorted wire in harness. ECU pin 29 to lamp open or shorted.
3. Vehicle Wiring Harness Related
 - a. Broken or shorted wire in harness. Power lead to MIL open or shorted.
4. ECU Related
 - a. Circuit controlling lamp damaged.

Section 5B

EFI Fuel System

Excerpt from Kohler service manual Wood-Mizer #3H0927B-9

Code: 56 "32 Pin" (MSE 1.1) Plastic-Cased ECU only.

Source: Fuel pump relay circuit open, shorted to ground, or shorted to battery.

Explanation: Fuel pump, ignition coils, and fuel injectors will not function because the fuel pump relay circuit is either open, shorted to ground, or may be "on" continuously if shorted to battery.

Expected Engine Response: Engine will not run, or fuel pump will continue to run when switch is off.

Possible Causes:

1. Fuel Pump Relay Related
 - a. Bad fuel pump relay.
Primary side open or shorted.
2. Fuel Pump Related
 - a. Fuel pump open or shorted internally.
3. Engine Wiring Harness Related
 - a. Fuel pump fuse F1 open.
 - b. Broken or shorted wire in harness.
ECU pin 28 to fuel pump relay pin 86.
Ignition switch to fuel pump relay pin 85.
4. ECU Related
 - a. Circuit controlling fuel pump relay damaged.

Code: 61

Source:

Explanation: Denotes the end of fault codes. If signaled first, no other fault codes are present.

Troubleshooting Flow Chart

The following flow chart (on page 5B.43) provides an alternative method of troubleshooting the EFI system. The chart will enable you to review the entire system in about 10-15 minutes. Using the chart, the accompanying diagnostic aids (listed after the chart), and any signaled fault codes, you should be able to quickly locate any problems within the system.

Section 5B

EFI Fuel System

Excerpt from Kohler service manual Wood-Mizer #3H0927B-9

Code: 56 "32 Pin" (MSE 1.1) Plastic-Cased ECU only.

Source: Fuel pump relay circuit open, shorted to ground, or shorted to battery.

Explanation: Fuel pump, ignition coils, and fuel injectors will not function because the fuel pump relay circuit is either open, shorted to ground, or may be "on" continuously if shorted to battery.

Expected Engine Response: Engine will not run, or fuel pump will continue to run when switch is off.

Possible Causes:

1. Fuel Pump Relay Related
 - a. Bad fuel pump relay.
Primary side open or shorted.
2. Fuel Pump Related
 - a. Fuel pump open or shorted internally.
3. Engine Wiring Harness Related
 - a. Fuel pump fuse F1 open.
 - b. Broken or shorted wire in harness.
ECU pin 28 to fuel pump relay pin 86.
Ignition switch to fuel pump relay pin 85.
4. ECU Related
 - a. Circuit controlling fuel pump relay damaged.

Code: 61

Source:

Explanation: Denotes the end of fault codes. If signaled first, no other fault codes are present.

Troubleshooting Flow Chart

The following flow chart (on page 5B.43) provides an alternative method of troubleshooting the EFI system. The chart will enable you to review the entire system in about 10-15 minutes. Using the chart, the accompanying diagnostic aids (listed after the chart), and any signaled fault codes, you should be able to quickly locate any problems within the system.

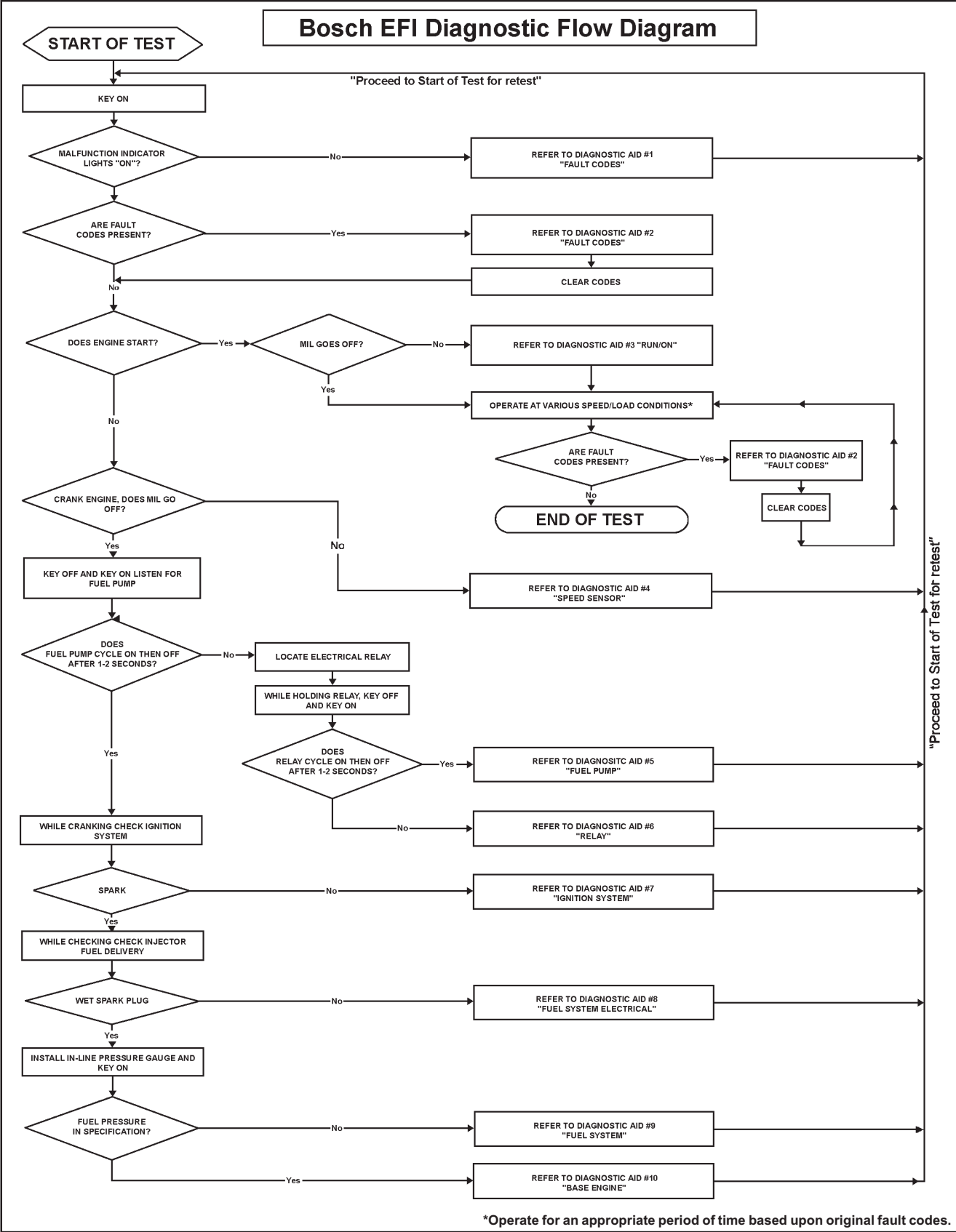

Figure 5B-44.

Section 5B

EFI Fuel System

Excerpt from Kohler service manual Wood-Mizer #3H0927B-11

Flow Chart Diagnostic Aids

Diagnostic Aid #1 "SYSTEM POWER" (MIL does not illuminate when key is turned "on")

Possible causes:

1. Battery
2. Main system fuse
3. MIL light bulb burned out
4. MIL electrical circuit problem
 - "35 Pin" (MA 1.7) Metal-Cased ECU: Pin circuits 31 and 31A.
 - "24 Pin" (MSE 1.0) Plastic-Cased ECU: Pin circuits 19 and 84.
 - "32 Pin" (MSE 1.1) Plastic-Cased ECU: Pin circuits 29 and 84.
5. Ignition switch
6. Permanent ECU power circuit problem
 - "35 Pin" (MA 1.7) Metal-Cased ECU: Pin circuit 16.
 - "24 Pin" (MSE 1.0) Plastic-Cased ECU: Pin circuit 1.
 - "32 Pin" (MSE 1.1) Plastic-Cased ECU: Pin circuit 1.
7. Switched ECU power circuit problem
 - "35 Pin" (MA 1.7) Metal-Cased ECU: Pin circuit 17.
 - "24 Pin" (MSE 1.0) Plastic-Cased ECU: Pin circuit 2.
 - "32 Pin" (MSE 1.1) Plastic-Cased ECU: Pin circuit 2.
8. ECU grounds
9. ECU

Diagnostic Aid #2 "FAULT CODES" (Refer to detailed fault code listing before flow chart and "servicing" information for the respective components)

1. Code 21 - Engine Speed Synchronization
2. Code 22 - Throttle Position Sensor (TPS)
3. Code 23 - Engine Control Unit (ECU)
4. Code 31 - Oxygen Sensor
5. Code 32 - Oxygen Sensor
6. Code 33 - Fuel System (temporary adaptation factor)
7. Code 34 - Fuel System (permanent adaptation factor)
8. Code 42 - Engine (Oil) Temperature Sensor
9. Code 43 - TPS "Auto-Learn" Initialization Function (Below Min. Limit), "32 Pin" (MSE 1.1) Plastic-Cased ECU only.
10. Code 44 - TPS "Auto-Learn" Initialization Function (Above Max. Limit), "32 Pin" (MSE 1.1) Plastic-Cased ECU only.

11. Code 51 - Injector 1, "32 Pin" (MSE 1.1) Plastic-Cased ECU only.
12. Code 52 - Injector 2, "32 Pin" (MSE 1.1) Plastic-Cased ECU only.
13. Code 55 - MIL Light, "32 Pin" (MSE 1.1) Plastic-Cased ECU only.
14. Code 56 - Pump Relay, "32 Pin" (MSE 1.1) Plastic-Cased ECU only.
15. Code 61 - End of Fault/Blink Code Transmission.

Diagnostic Aid #3 "RUN/ON" (MIL remains "on" while engine is running)*

Possible causes:

1. Fault codes which turn on MIL when engine is running.
 - a. Code 21 - Engine Speed Synchronization
 - b. Code 22 - Throttle Position Sensor (TPS)
 - c. Code 23 - Engine Control Unit (ECU)
 - d. Code 31 - Oxygen Sensor (shorted)
 - e. Code 34 - Fuel System (permanent adaptation at limit)
 - f. Code 42 - Engine (Oil) Temperature Sensor
 - g. Code 43 - TPS "Auto-Learn" Initialization Function (Below Min. Limit), "32 Pin" (MSE 1.1) Plastic-Cased ECU only.
 - h. Code 44 - TPS "Auto-Learn" Initialization Function (Above Max. Limit) "32 Pin" (MSE 1.1) Plastic-Cased ECU only.
 - i. Code 51 - Injector 1, "32 Pin" (MSE 1.1) Plastic-Cased ECU only.
 - j. Code 52 - Injector 2, "32 Pin" (MSE 1.1) Plastic-Cased ECU only.
 - k. Code 55 - MIL Light, "32 Pin" (MSE 1.1) Plastic-Cased ECU only.
 - l. Code 56 - Pump Relay, "32 Pin" (MSE 1.1) Plastic-Cased ECU only.
2. MIL circuit grounded between light and ECU.
 - "35 Pin" (MA 1.7) Metal-Cased ECU: Pin circuit 31.
 - "24 Pin" (MSE 1.0) Plastic-Cased ECU: Pin circuit 19.
 - "32 Pin" (MSE 1.1) Plastic-Cased ECU: Pin circuit 29.
3. ECU

*NOTE: MIL in Metal-Cased ECU systems is an LED. The MIL in Plastic-Cased ECU systems must be a 1/4 watt incandescent lamp.

Diagnostic Aid #4 "SPEED SENSOR" (MIL does not turn off during cranking). Indicates the ECU is not receiving a signal from the speed sensor.

Possible causes:

1. Speed sensor
2. Speed sensor circuit problem
 - "35 Pin" (MA 1.7) Metal-Cased ECU: Pin circuits 3 and 21.
 - "24 Pin" (MSE 1.0) Plastic-Cased ECU: Pin circuits 9 and 10.
 - "32 Pin" (MSE 1.1) Plastic-Cased ECU: Pin circuits 9 and 10.
3. Speed sensor/toothed wheel air gap
4. Toothed wheel
5. Flywheel key sheared
6. ECU

Diagnostic Aid #5 "FUEL PUMP" (fuel pump not turning on)

Possible causes:

1. Fuel pump fuse
2. Fuel pump circuit problem
 - "35 Pin" (MA 1.7) Metal-Cased ECU: Circuits 43, 44, and relay.
 - "24 Pin" (MSE 1.0) Plastic-Cased ECU: Circuits 30, 87, and relay.
 - "32 Pin" (MSE 1.1) Plastic-Cased ECU: Circuits 30, 87, and relay.
3. Fuel pump

Diagnostic Aid #6 "RELAY" (relay not operating)

Possible causes:

1. Safety switches/circuit(s) problem
 - "35 Pin" (MA 1.7) Metal-Cased ECU: Circuits 41 and 41A.
 - "24 Pin" (MSE 1.0) Plastic-Cased ECU: Circuit 3.
 - "32 Pin" (MSE 1.1) Plastic-Cased ECU: Circuit 25.
2. Relay circuit(s) problem
 - "35 Pin" (MA 1.7) Metal-Cased ECU: Circuits 28, 41, and 41A.
 - "24 Pin" (MSE 1.0) Plastic-Cased ECU: Circuits 18, 85, 30, and 87.
 - "32 Pin" (MSE 1.1) Plastic-Cased ECU: Circuits 28, 85, 30, and 87.
3. Relay
4. ECU grounds
5. ECU

Diagnostic Aid #7 "IGNITION SYSTEM" (no spark)

Possible causes:

1. Spark plug
2. Plug wire
3. Coil
4. Coil circuit(s)
 - "35 Pin" (MA 1.7) Metal-Cased ECU: Circuits 1, 19, 40, 40A, 43, and relay.
 - "24 Pin" (MSE 1.0) Plastic-Cased ECU: Circuits 22, 23, 65, 66, 30, and relay.
 - "32 Pin" (MSE 1.1) Plastic-Cased ECU: Circuits 30, 31, 65, 66, relay and relay circuit 30.
5. ECU grounds
6. ECU

Diagnostic Aid #8 "FUEL SYSTEM-ELECTRICAL" (no fuel delivery)

Possible causes:

1. No fuel
2. Air in fuel rail
3. Fuel valve shut off
4. Fuel filter/line plugged
5. Injector circuit(s)
 - "35 Pin" (MA 1.7) Metal-Cased ECU: Circuits 35, 35A, 45, and 45A.
 - "24 Pin" (MSE 1.0) Plastic-Cased ECU: Circuits 16, 17, 45, and 45A.
 - "32 Pin" (MSE 1.1) Plastic-Cased ECU: Circuits 14, 15, and 45.
6. Injector
7. ECU grounds
8. ECU

Diagnostic Aid #9 "FUEL SYSTEM" (fuel pressure)

Possible causes for low fuel system pressure:

1. Low fuel
2. Fuel filter plugged
3. Fuel supply line plugged
4. Pressure regulator
5. Fuel pump

Possible causes for high fuel system pressure:

1. Pressure regulator
2. Fuel return line plugged or restricted.

Diagnostic Aid #10 "BASIC ENGINE" (cranks but will not run)

Possible causes:

1. Refer to basic engine troubleshooting charts within service manual sections 3, 5, and 8.