



Wood-Mizer[®] Sawmill

Parts Manual

LT30HD
LT40HD

rev. G1.00 - J7.00
rev. G1.00 - J8.00



Safety is our #1 concern! Read and understand all safety information and instructions before operating, setting up or maintaining this machine.

January 1999

Form #760

Table of Contents

Section-Page

SECTION 1	GENERAL INFORMATION	1-1
1.1	How To Use The Parts List	1-1
1.2	Sample Assembly	1-1
SECTION 2	BLADE GUIDE ROLLERS & ARM	2-1
2.1	Blade Guide Assembly, Idle Side.....	2-1
	<i>LT30HD Retrofit</i>	
	<i>LT40HD Retrofit</i>	
2.2	Blade Guide Assembly, Idle Side.....	2-4
	<i>LT30HD Rev. J6.00 - J7.00</i>	
	<i>LT40HD Rev. J7.00 - J8.00</i>	
2.3	Blade Guide Assembly, Idle Side.....	2-7
	<i>LT30HD Rev. H9.00 - J5.07</i>	
	<i>LT40HD Rev. H9.00 - J6.08</i>	
2.4	Blade Guide Assembly, Idle Side.....	2-10
	<i>LT30HD Rev. G1.00 - H8.01</i>	
	<i>LT40HD Rev. G1.00 - H8.01</i>	
2.5	Blade Guide Assembly, Drive Side.....	2-12
	<i>LT30HD Retrofit</i>	
	<i>LT40HD Retrofit</i>	
2.6	Blade Guide Assembly, Drive Side.....	2-15
	<i>LT30HD Rev. J6.00 - J7.00</i>	
	<i>LT40HD Rev. J7.00 - J8.00</i>	
2.7	Blade Guide Assembly, Drive Side.....	2-18
	<i>LT30HD Rev. H9.00 - J5.07</i>	
	<i>LT40HD Rev. H9.00 - J6.08</i>	
2.8	Blade Guide Assembly, Drive Side.....	2-21
	<i>LT30HD Rev. G1.00 - H8.01</i>	
	<i>LT40HD Rev. G1.00 - H8.01</i>	
2.9	Blade Guide Arm Drive Assembly.....	2-23
2.10	Blade Guide Arm.....	2-25
SECTION 3	BLADE WHEELS & TENSIONER	3-1
3.1	Blade Drive Assembly.....	3-1
	<i>LT30HD D33 Rev. H8.00 - J7.00</i>	
	<i>LT40HD D33 Rev. H8.00 - J8.00</i>	
	<i>LT30HD G36 Rev. J1.00 - J7.00</i>	
	<i>LT40HD G36 Rev. J1.00 - J8.00</i>	
3.2	Blade Drive Assembly.....	3-3
	<i>LT30HD G25 Rev. H6.00 - J7.00</i>	
	<i>LT40HD G25 Rev. H6.00 - J8.00</i>	
	<i>LT30HD D33 Rev. H6.00 - H7.00</i>	
	<i>LT40HD D33 Rev. H6.00 - H7.00</i>	
3.3	Blade Drive Assembly.....	3-5
	<i>LT30HD Rev. G7.00 - H5.00</i>	
	<i>LT40HD Rev. G7.00 - H5.00</i>	
3.4	Blade Drive Assembly.....	3-7
	<i>LT30HD Rev. G1.00 - G6.06</i>	

Table of Contents

Section-Page

3.5	<i>LT40HD</i> <i>Rev. G1.00 - G6.06</i> Idle Blade Wheel Assembly	3-9
	<i>LT30HD</i> <i>Rev. H6.00 - J7.00</i> <i>LT40HD</i> <i>Rev. H6.00 - J8.00</i>	
3.6	Idle Blade Wheel Assembly	3-11
	<i>LT30HD</i> <i>Rev. G7.00 - H5.00</i> <i>LT40HD</i> <i>Rev. G7.00 - H5.00</i>	
3.7	Idle Blade Wheel Assembly	3-13
	<i>LT30HD</i> <i>Rev. G1.00 - G6.06</i> <i>LT40HD</i> <i>Rev. G1.00 - G6.06</i>	
3.8	Hydraulic Blade Tensioner Assembly.....	3-15

SECTION 4 SAW HEAD

4-1

4.1	Middle Throat Screw.....	4-1
4.2	Clutch/Brake Lever Assembly (D33/G36).....	4-2
	<i>LT30HD</i> <i>Rev. H8.00 - J7.00</i> <i>LT40HD</i> <i>Rev. H8.00 - J8.00</i>	
4.3	Clutch/Brake Lever Assembly (D33).....	4-4
	<i>LT30HD</i> <i>Rev. H3.00 - H7.00</i> <i>LT40HD</i> <i>Rev. H3.00 - H7.00</i>	
4.4	Clutch/Brake Lever Assembly (G25).....	4-6
	<i>LT30HD</i> <i>Rev. H3.00 - J7.00</i> <i>LT40HD</i> <i>Rev. H3.00 - J8.00</i>	
4.5	Clutch/Brake Lever Assembly.....	4-8
	<i>LT30HD</i> <i>Rev. G1.00 - H2.00</i> <i>LT40HD</i> <i>Rev. G1.00 - H2.00</i>	
4.6	Clutch Mount Assembly.....	4-10
	<i>LT30HD</i> <i>Rev. H3.00 - J7.00</i> <i>LT40HD</i> <i>Rev. H3.00 - J8.00</i>	
4.7	Clutch Mount Assembly.....	4-11
	<i>LT30HD</i> <i>Rev. G1.00 - H2.00</i> <i>LT40HD</i> <i>Rev. G1.00 - H2.00</i>	
4.8	Brake Assembly.....	4-12
4.9	Water Lube Assembly.....	4-13
4.10	Saw Head Decals.....	4-15
4.11	Blade Housing Covers.....	4-16
	<i>LT30HD</i> <i>Rev. G4.00 - J7.00</i> <i>LT40HD</i> <i>Rev. G4.00 - J8.00</i>	
4.12	Blade Housing Covers.....	4-18
	<i>LT30HD</i> <i>Rev. G1.00 - G3.00</i> <i>LT40HD</i> <i>Rev. G1.00 - G3.00</i>	
4.13	Drive Belt Covers.....	4-20
4.14	Sawdust Chute.....	4-21
	<i>LT30HD</i> <i>Rev. G2.00 - J7.00</i> <i>LT40HD</i> <i>Rev. G2.00 - J8.00</i>	

Table of Contents

Section-Page

4.15	Sawdust Chute	4-22
	<i>LT30HD</i> <i>Rev. G1.00</i>	
	<i>LT40HD</i> <i>Rev. G1.00</i>	
4.16	Debarker Wire Box/Hole Plugs.....	4-23
SECTION 5	CONTROL & BATTERY BOXES	5-1
5.1	Control Assembly.....	5-1
	<i>LT30HD</i> <i>Rev. J5.00 - J7.00</i>	
	<i>LT40HD</i> <i>Rev. J6.00 - J8.00</i>	
5.2	Control Assembly.....	5-3
	<i>LT30HD</i> <i>Rev. G6.00 - J4.00</i>	
	<i>LT40HD</i> <i>Rev. G6.00 - J5.00</i>	
5.3	Control Assembly.....	5-6
	<i>LT30HD</i> <i>Rev. G1.00 - G5.02</i>	
	<i>LT40HD</i> <i>Rev. G1.00 - G5.00</i>	
5.4	Drum Switches	5-9
5.5	Circuit Breakers.....	5-10
	<i>LT30HD</i> <i>Rev. G6.00 - J7.00</i>	
	<i>LT40HD</i> <i>Rev. G6.00 - J8.00</i>	
5.6	Front Panel Assembly & Harnesses	5-11
	<i>LT30HD</i> <i>Rev. J5.00 - J7.00</i>	
	<i>LT40HD</i> <i>Rev. J6.00 - J8.00</i>	
5.7	Front Panel Assembly & Harnesses	5-13
	<i>LT30HD</i> <i>Rev. G3.00 - J4.00</i>	
	<i>LT40HD</i> <i>Rev. G3.00 - J5.00</i>	
5.8	Front Panel Assembly & Harnesses	5-15
	<i>LT30HD</i> <i>Rev. G1.00 - G2.05</i>	
	<i>LT40HD</i> <i>Rev. G1.00 - G2.05</i>	
5.9	Battery Box Assembly.....	5-17
5.10	Fuse Box Assembly.....	5-19
	<i>LT30HD</i> <i>Rev. J5.00 - J7.00</i>	
	<i>LT40HD</i> <i>Rev. J6.00 - J8.00</i>	
5.11	Fuse Box Assembly.....	5-21
	<i>LT30HD</i> <i>Rev. G1.00 - J4.00</i>	
	<i>LT40HD</i> <i>Rev. G1.00 - J5.00</i>	
SECTION 6	UP/DOWN SYSTEM	6-1
6.1	Saw Head Mount.....	6-1
6.2	Blade Height & Quarter Scales	6-3

Table of Contents

Section-Page

6.3	Up/Down Chain & Sprockets.....	6-5
	<i>LT30HD</i> <i>Rev. G7.01 - J7.00</i>	
	<i>LT40HD</i> <i>Rev. G7.01 - J8.00</i>	
6.4	Up/Down Chain & Sprockets.....	6-7
	<i>LT30HD</i> <i>Rev. G6.00 - G7.00</i>	
	<i>LT40HD</i> <i>Rev. G6.00 - G7.00</i>	
6.5	Up/Down Chain & Sprockets.....	6-9
	<i>LT30HD</i> <i>Rev. G1.00 - G5.02</i>	
	<i>LT40HD</i> <i>Rev. G1.00 - G5.02</i>	
6.6	Up/Down Assembly, G24/G25	6-11
6.7	Up/Down Assembly, D33/G36	6-13
	<i>LT30HD</i> <i>Rev. J6.00 - J7.00</i>	
	<i>LT40HD</i> <i>Rev. J7.00 - J8.00</i>	
6.8	Up/Down Assembly, D30/D33/G36	6-15
	<i>LT30HD</i> <i>Rev. G1.00 - J5.07</i>	
	<i>LT40HD</i> <i>Rev. G1.00 - J6.08</i>	
SECTION 7	FEED SYSTEM & TRACK ROLLERS	7-1
7.1	Upper Track Rollers And Wipers.....	7-1
	<i>LT30HD</i> <i>Rev. H2.00 - J7.00</i>	
	<i>LT40HD</i> <i>Rev. H2.00 - J8.00</i>	
7.2	Upper Track Rollers And Wipers.....	7-3
	<i>LT30HD</i> <i>Rev. G1.00 - H1.00</i>	
	<i>LT40HD</i> <i>Rev. G1.00 - H1.00</i>	
7.3	Power Feed Assembly	7-4
7.4	Feed Chain/Stop	7-6
	<i>LT30HD</i> <i>Rev. G9.00 - J7.00</i>	
	<i>LT40HD</i> <i>Rev. G9.00 - J8.00</i>	
7.5	Feed Chain/Stop	7-8
	<i>LT30HD</i> <i>Rev. G6.00 - G8.00</i>	
	<i>LT40HD</i> <i>Rev. G6.00 - G8.00</i>	
7.6	Feed Chain/Stop	7-10
	<i>LT30HD</i> <i>Rev. G1.00 - G5.02</i>	
	<i>LT40HD</i> <i>Rev. G1.00 - G5.02</i>	
7.7	Lower Track Rollers.....	7-12
	<i>LT30HD</i> <i>Rev. H7.00 - J7.00</i>	
	<i>LT40HD</i> <i>Rev. H7.00 - J7.00</i>	
7.8	Lower Track Rollers.....	7-13
	<i>LT30HD</i> <i>Rev. G1.00 - H6.02</i>	
	<i>LT40HD</i> <i>Rev. G1.00 - H6.02</i>	
SECTION 8	BED FRAME ASSEMBLY	8-1
8.1	Bed Rail Assembly, Front And Rear.....	8-1
8.2	Bed Rail Assembly, Middle Front.....	8-3
8.3	Bed Rail Assembly, Middle Rear.....	8-4
8.4	Leg Assembly (Stationary).....	8-6
	<i>LT15BS</i> <i>Rev. E.00+</i>	
8.5	Pivot Bed Rail Assembly.....	8-8

Table of Contents

Section-Page

8.6	Log Side Support Assembly (Manual).....	8-10
	<i>LT30HD</i> <i>Rev. H8.00 - J7.00</i>	
	<i>LT40HD</i> <i>Rev. H8.00 - J8.00</i>	
8.7	Log Side Support Assembly (Manual).....	8-12
	<i>LT30HD</i> <i>Rev. G1.00 - H7.00</i>	
	<i>LT40HD</i> <i>Rev. G1.00 - H7.00</i>	
8.8	Safety Chain Assembly	8-14
8.9	Saw Head Rest Pin Assembly	8-15
8.10	Bed Frame Decals.....	8-16
SECTION 9	MISCELLANEOUS	9-1
9.1	Replacement Manuals	9-1
SECTION 10	HYDRAULIC SYSTEM	10-1
10.1	Hydraulic Hoses	10-1
	<i>LT30HD</i> <i>Rev. G6.00 - J7.00</i>	
	<i>LT40HD</i> <i>Rev. G6.00 - J8.00</i>	
10.2	Hydraulic Hoses	10-3
	<i>LT30HD</i> <i>Rev. G1.00 - G5.02</i>	
	<i>LT40HD</i> <i>Rev. G1.00 - G5.02</i>	
10.3	Hydraulic Control Box	10-4
	<i>LT30HD</i> <i>Rev. G6.00 - J7.00</i>	
	<i>LT40HD</i> <i>Rev. G6.00 - J8.00</i>	
10.4	Hydraulic Control Box	10-7
	<i>LT30HD</i> <i>Rev. G4.00 - G5.02</i>	
	<i>LT40HD</i> <i>Rev. G4.00 - G5.02</i>	
10.5	Hydraulic Control Box	10-10
	<i>LT30HD</i> <i>Rev. G1.00 - G3.00</i>	
	<i>LT40HD</i> <i>Rev. G1.00 - G3.00</i>	
10.6	Hydraulic Power Supply Strip.....	10-13
	<i>LT30HD</i> <i>Rev. J2.00 - J7.00</i>	
	<i>LT40HD</i> <i>Rev. J2.00 - J8.00</i>	
10.7	Hydraulic Power Supply Strip.....	10-15
	<i>LT30HD</i> <i>Rev. G1.00 - J1.00</i>	
	<i>LT40HD</i> <i>Rev. G1.00 - J1.00</i>	
10.8	Hydraulic Log Loader	10-17
	<i>LT30HD</i> <i>Rev. H7.00 - J7.00</i>	
	<i>LT40HD</i> <i>Rev. H7.00 - J8.00</i>	
10.9	Hydraulic Log Loader	10-19
	<i>LT30HD</i> <i>Rev. G1.00 - H6.02</i>	
	<i>LT40HD</i> <i>Rev. G1.00 - H6.02</i>	
10.10	Hydraulic Log Turner.....	10-21
10.11	Hydraulic Log Side Supports	10-23
	<i>LT30HD</i> <i>Rev. H8.00 - J7.00</i>	
	<i>LT40HD</i> <i>Rev. H8.00 - J8.00</i>	
10.12	Hydraulic Log Side Supports	10-26
	<i>LT30HD</i> <i>Rev. H5.00 - H7.00</i>	
	<i>LT40HD</i> <i>Rev. H5.00 - H7.00</i>	

Table of Contents

Section-Page

10.13	Hydraulic Log Side Supports	10-28
	<i>LT30HD</i> <i>Rev. G1.00 - H4.00</i>	
	<i>LT40HD</i> <i>Rev. G1.00 - H4.00</i>	
10.14	Hydraulic Log Side Supports (Middle - Optional).....	10-30
	<i>LT30HD</i> <i>Rev. G6.00+</i>	
	<i>LT40HD</i> <i>Rev. G6.00+</i>	
10.15	Hydraulic Log Clamp	10-31
	<i>LT30HD</i> <i>Rev. H3.00 - J7.00</i>	
	<i>LT40HD</i> <i>Rev. H3.00 - J8.00</i>	
10.16	Hydraulic Log Clamp	10-33
	<i>LT30HD</i> <i>Rev. G6.00 - H2.00</i>	
	<i>LT40HD</i> <i>Rev. G6.00 - H2.00</i>	
10.17	Hydraulic Log Clamp	10-35
	<i>LT30HD</i> <i>Rev. G1.00 - G5.02</i>	
	<i>LT40HD</i> <i>Rev. G1.00 - G5.02</i>	
10.18	Hydraulic Toe Board	10-38

INDEX

I

SECTION 1 GENERAL INFORMATION

1.1 How To Use The Parts List

- Use the table of contents or index to locate the assembly that contains the part you need.
- Go to the appropriate section and locate the part in the illustration.
- Use the number pointing to the part to locate the correct part number and description in the table.
- Parts shown indented under another part are included with that part.
- Parts marked with a diamond (◆) are only available in the assembly listed above the part.

See the sample table below. Sample Part #A01111 includes part F02222-2 and subassembly A03333. Subassembly A03333 includes part S04444-4 and subassembly K05555. The diamond (◆) indicates that S04444-4 is not available except in subassembly A03333. Subassembly K05555 includes parts M06666 and F07777-77. The diamond (◆) indicates M06666 is not available except in subassembly K05555.

1.2 Sample Assembly				
REF	DESCRIPTION (◆ Indicates Parts Available In Assemblies Only)	PART #	QTY.	
	SAMPLE ASSEMBLY, COMPLETE (INCLUDES ALL INDENTED PARTS BELOW)	A01111	1	
1	Sample Part	F02222-22	1	
	Sample Subassembly (Includes All Indented Parts Below)	A03333	1	
2	Sample Part (◆ Indicates Part Is Only Available With A03333)	S04444-4	1	◆
	Sample Subassembly (Includes All Indented Parts Below)	K05555	1	
3	Sample Part (◆ Indicates Part Is Only Available With K05555)	M06666	2	◆
4	Sample Part	F07777-77	1	

To Order Parts:

- From the continental U.S., call **1-800-525-8100** to order parts. Have your customer number, vehicle identification number, and part numbers ready when you call.
- From other international locations, contact the Wood-Mizer distributor in your area for parts.

SECTION 2 BLADE GUIDE ROLLERS & ARM

2.1 Blade Guide Assembly, Idle Side

LT30HD
LT40HD

Retrofit
Retrofit

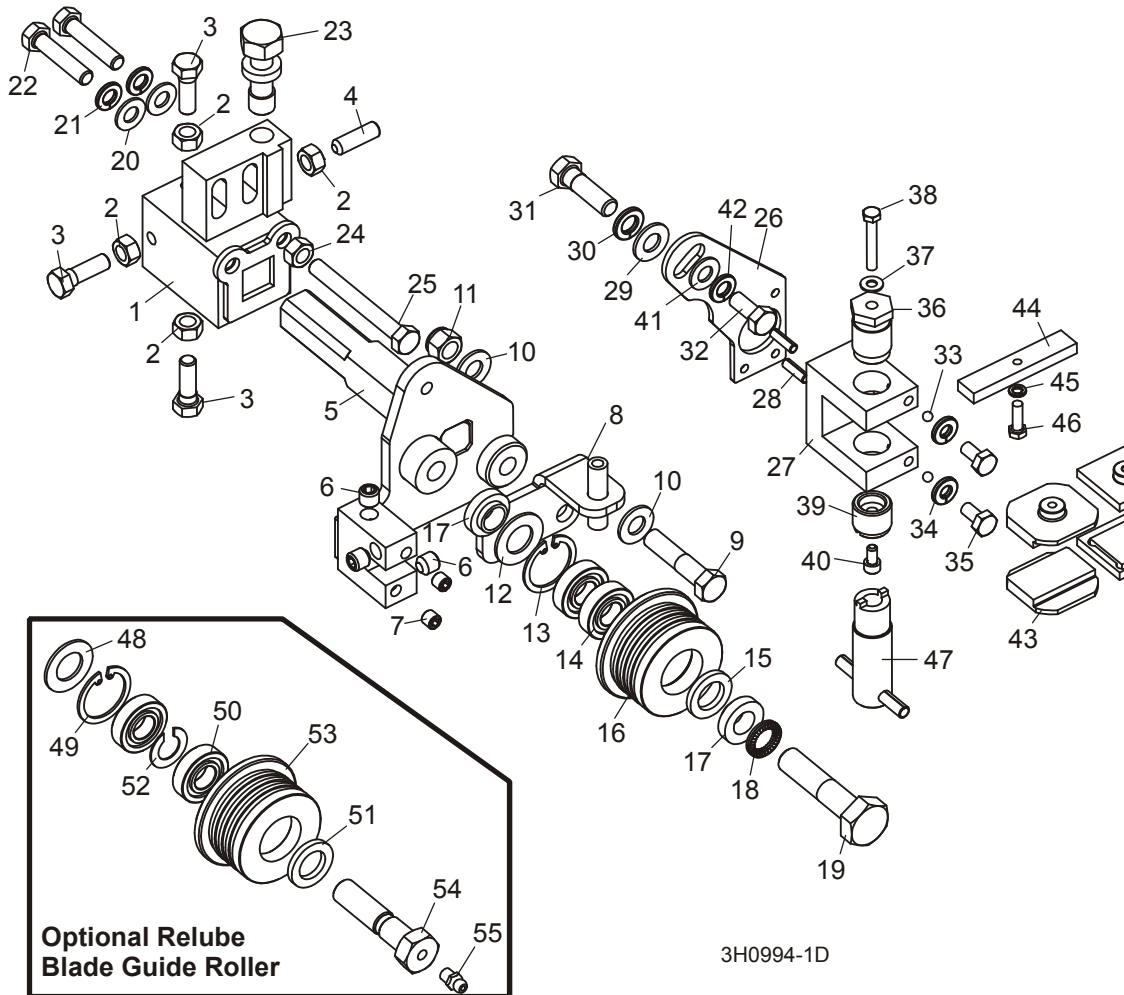

REF	DESCRIPTION (◆ Indicates Parts Available In Assemblies Only)	PART #	QTY.
	GUIDE ASSEMBLY, IDLE SIDE BLADE ROLLER	003992	1
	Block Assembly, Idle Side Blade Guide Mount	003920	1
1	Block Weldment, Blade Guide Mount	003921	1 ◆
2	Nut, 5/16-18 Hex	F05010-17	4
3	Bolt, 5/16-18 x 1" Hex Head Stainless Steel	F05006-88	3
4	Screw, 5/16-18 x 1" Socket Head Flat Point Stainless Steel Set	F05006-122	1
5	Shaft Weldment, IdleSide Guide	003924 ¹	1
6	Fitting, 1/8" NPT Socket Pipe Plug	P30127	3

2

Blade Guide Rollers & Arm

Blade Guide Assembly, Idle Side

7	Fitting, 1/16" NPT Socket Pipe Plug	007734 ¹	2	
8	Bracket Weldment, Idle Side Water Lube	006322	1	
9	Bolt, 3/8-16UNF-2A x 1 3/4" Grade 5	F05007-119	1	
10	Washer, 3/8" SAE Flat	F05011-3	2	
11	Nut, 3/8-16 Hex Nylon Lock	F05010-10	1	
	Roller Assembly, Blade Guide (standard)	A04925	1	
	Bearing Kit, Blade Guide Rebuild	K07079	1	
12	Washer, 5/8" White Felt	P04252	1	
13	Ring, 1 1/8" Interior Retaining	F04254-1	1	
14	Bearing, R8-2RS Blade Guide	015975	2	◆
15	Washer, 5/8" Gray Felt	P06455	1	
	Screw, 1/4-28 x 1/4" Socket Head Cup Point Set Black Oxide	F05005-105	1	
	Instruction Sheet, Blade Guide Rebuild	057407-1507	1	
16	Roller, Flanged Blade Guide	S04250	1	◆
	Instruction Sheet, Blade Guide Roller Replacement	A04925-364	1	
17	Spacer, Blade Guide	S04253	2	
18	Washer, 1/2" Nord-Lock	F05011-125 ²	1	
19	Bolt, 1/2-13 x 2 1/4" Hex Head Grade 5	F05008-10	1	
20	Washer, 5/16" SAE Flat	F05011-17	2	
21	Washer, 5/16" Split Lock	F05011-13	2	
22	Bolt, 5/16-18 x 1 1/2" Hex Head	F05006-76	2	
23	Bolt, Blade Guide Vertical Adjustment	035656	1	
24	Nut, 5/16-18 Hex	F05010-17	1	
25	Bolt, 5/16-18 x 2 1/4" Hex Head Full Thread	F05006-16	1	
	BLOCK ASSEMBLY, IDLE SIDE BLADE GUIDE	003928	1	
26	Plate, Block Tilt Adjustment	003915	1	
27	Block, Guide Block Mount	003909	1	
28	Pin, 3/16" x 5/8" Roll	F05012-22	2	
29	Washer, 3/8" SAE Flat	F05011-3	1	
30	Washer, 3/8" Split Lock	F05011-4	1	
31	Bolt, 3/8-16 x 1 1/4" Hex Head Grade 5	F05007-123	1	
32	Bolt, 5/16-18 x 3/4" Hex Head w/Flat & Lock Washer	F05006-101	1	
33	Ball, 3/16" Dia. Nylon	003914	2	
34	Washer, 1/4" Split Lock	F05011-14	2	
35	Bolt, 1/4-20 x 1/2" Hex Head	F05005-15	2	
36	Bolt, Blade Guide Block Mount	003994	1	
37	Washer, #10 Brass	042867	1	
38	Bolt, #10-32 x 1 1/4" Hex Head Stainless Steel	F05004-240	1	
39	Screw, Lower Block Adjustment	044057	1	
40	Screw, #10-32 x 3/8" Socket Head Stainless Steel	F05004-200	1	
41	BLOCK, BLADE GUIDE WEAR (STANDARD FOR 1 1/4" BLADES)	052355 ³	2	
	BLOCK ASSEMBLY, 1" SQ. EZ-GLIDE WEAR	036347 ³	2	
42	BLOCK, BLADE GUIDE ALIGNMENT	035799	1	

Blade Guide Rollers & Arm

Blade Guide Assembly, Idle Side

2

43	WASHER, #10 SPLIT LOCK	F05011-20	1	
44	SCREW, #10-32 X 5/8" HEX HEAD	F05004-152	1	
45	ADJUSTMENT TOOL, LOWER GUIDE BLOCK	044064	1	
	SHIM, .008" BLADE GUIDE BLOCK SPACER	035248	1	
	ROLLER ASSEMBLY, BLADE GUIDE RELUBE (OPTIONAL)	016568	1	
	Bearing Kit, Relube Blade Guide Rebuild	057407	1	
46	Washer, 5/8" White Felt	P04252	1	
47	Ring, 1 1/8" Interior Retaining	F04254-1	1	
48	Bearing, R8-2RS Blade Guide	015975 ⁴	2	◆
49	Washer, 5/8" Gray Felt	P06455	1	
50	Spacer, Blade Guide Bearing	035411	1	
	Instruction Sheet, Blade Guide Rebuild	057407-1507	1	
51	Roller, Flanged Blade Guide (Relube)	035426	1	◆
	Instruction Sheet, Blade Guide Roller Replacement	A04925-364	1	
52	BOLT, BLADE GUIDE ROLLER (RELUBE ONLY)	036161	1	
53	FITTING, 1/4-28 GREASE (RELUBE ONLY)	P05060	1	

¹ Shaft Weldment 003924 modified to provide more clearance for adjustment bolts and to prevent water leaks (12/09). New shaft requires two 1/16" NPT Pipe Plugs 007734.

² Nord-Lock Washer F05011-125 replaced Split Lock Washer F05011-9 to prevent loosening due to vibration (12/09).

³ 052355 blocks for use with 1 1/4" blade provided as standard equipment. EZ-Glide blocks 036347 are available for customers who prefer this block.

⁴ Bearing must be modified for use with relube roller assemblies. Remove one seal from each bearing, place open sides facing each other and place spacer 035411 between bearings.

2 Blade Guide Rollers & Arm

Blade Guide Assembly, Idle Side

2.2 Blade Guide Assembly, Idle Side

LT30HD
LT40HD

Rev. J6.00 - J7.00
Rev. J7.00 - J8.00

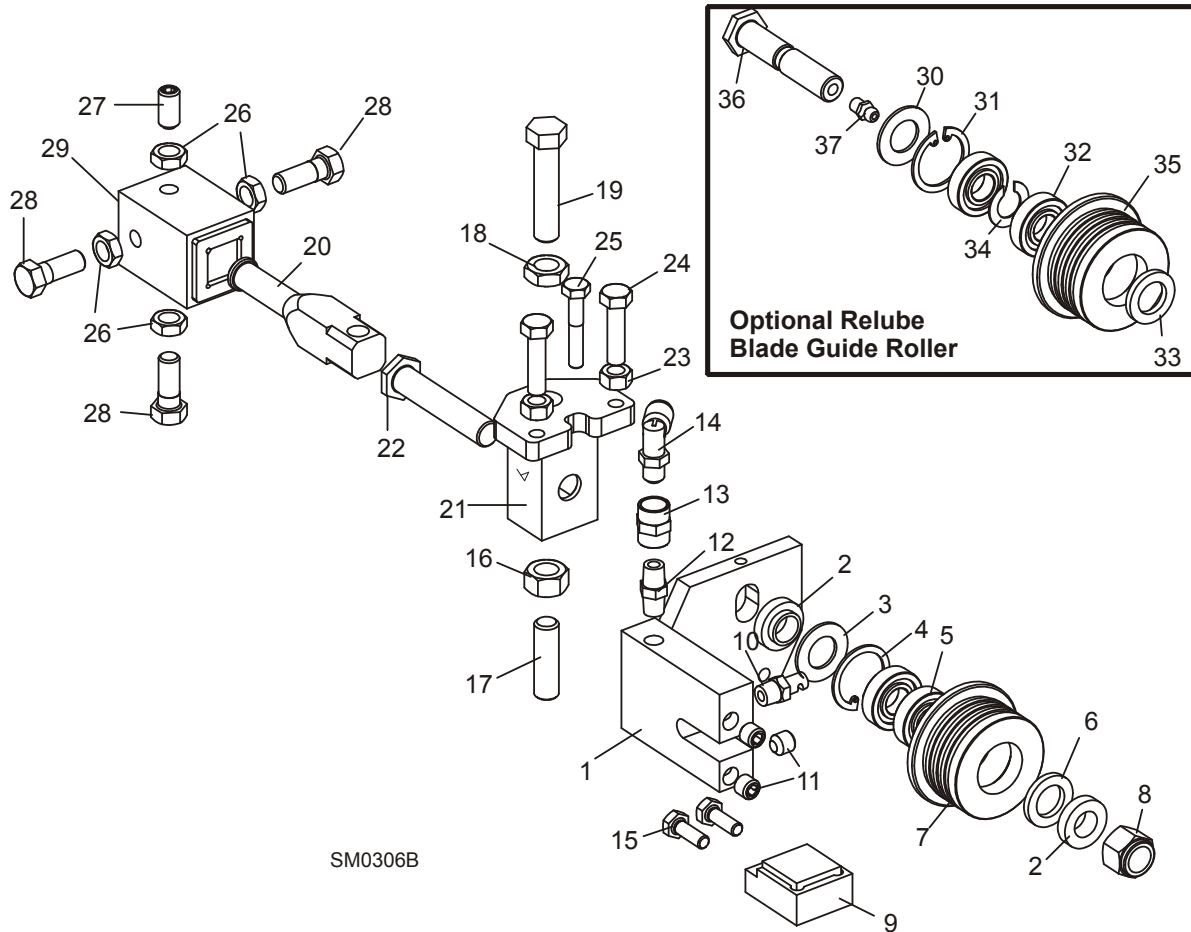

REF	DESCRIPTION (◆ Indicates Parts Available In Assemblies Only)	PART #	QTY.
	ROLLER/BLOCK ASSEMBLY, IDLE SIDE (OUTER)	035405 ¹	1
1	Nozzle Block Weldment, Idle Side	035404	1
2	Spacer, .510 x .937 x .34	S04253	2
	Roller Assembly, Blade Guide (standard)	A04925	1
	Bearing Kit, Blade Guide Rebuild	K07079	1
3	Washer, 5/8" White Felt	P04252	1
4	Ring, 1 1/8" Interior Retaining	F04254-1	1
5	Bearing, R8-2RS Blade Guide	015975	2
6	Washer, 5/8" Gray Felt	P06455	1
	Screw, 1/4-28 x 1/4" Socket Head Cup Point Set Black Oxide	F05005-105	1
	Instruction Sheet, Blade Guide Rebuild	057407-1507	1
7	Roller, Flanged Blade Guide (1 1/4" & 1 1/2" blade)	S04250	1

Blade Guide Rollers & Arm

Blade Guide Assembly, Idle Side

2

	Instruction Sheet, Blade Guide Roller Replacement	A04925-364	1	
8	Nut, 1/2-20 Nylon Hex Lock	F05010-15	1	
9	Block Assembly, 1 1/4" Blade EZ-Glide Wear	036247 ²	1	
	Block, 1 1/4" Blade Guide Wear	052367 ²	1	
10	Nozzle, Blade Water Lube Spray (For use with standard bottle water lube)	016637 ³	1	
11	Fitting, 1/8" NPT Socket Pipe Plug	P30127	3	
12	Fitting, 1/8" Dry Seal Nipple	P02764	1	
13	Fitting, 1/8" FPT Coupling	P05748	1	
14	Fitting, 1/8" MPT x 1/4" Tube 90° Elbow Swivel	P09736	1	
15	Bolt, 1/4-20 x 3/4" Hex Head Grade 5	F05005-123	2	
	Shaft Kit, Blade Guide Adjust Retrofit	038971 ⁴	1	
16	Nut, 7/16-20 Hex	F05010-202 ⁵	1	
17	Screw, 7/16-20 x 1 1/2" Socket Head Cup Point Stainless Steel	F05007-217 ⁶	1	
18	Nut, 7-16-20 Hex Jam	F05010-38	1	
19	Bolt, 7/16-20 x 2" Hex Head Full Thread Grade 8	F05007-215	1	
20	Shaft, Blade Guide Mount	054966	1	
21	Block Weldment, Roller Guide Adjuster	054969	1	
22	Bolt, Blade Guide Roller	036374	1	
23	Nut, 5/16-24 Hex	F05010-28	2	
24	Bolt, 5/16-24 x 1 1/4" Hex Head Full Thread Grade 5	F05006-107	2	
25	Bolt, 1/4-28 x 1 1/2" Hex Head Grade 5	F05005-143	1	
	SHIM, .008" CERAMIC INSERT SPACER	035248	1	
26	NUT, 3/8-24 HEX JAM	F05010-22	4	
27	SCREW, 3/8-24 X 3/4" STAINLESS STEEL SOCKET HEAD FLAT POINT	F05007-95	1	
28	BOLT, 3/8-24 X 1" STAINLESS STEEL HEX HEAD	F05007-99	3	
29	TUBE, BLADE GUIDE MOUNT (See Section 2.4)	W08159	1	
	ROLLER ASSEMBLY, BLADE GUIDE RELUBE (OPTIONAL)	016568	1	
	Bearing Kit, Relube Blade Guide Rebuild	057407	1	
30	Washer, 5/8" White Felt	P04252	1	
31	Ring, 1 1/8" Interior Retaining	F04254-1	1	
32	Bearing, R8-2RS Blade Guide	015975 ⁷	2	◆
33	Washer, 5/8" Gray Felt	P06455	1	
34	Spacer, Blade Guide Bearing	035411	1	
	Instruction Sheet, Blade Guide Rebuild	057407-1507	1	
35	Roller, Flanged Blade Guide (Relube)	035426	1	◆
	Instruction Sheet, Blade Guide Roller Replacement	A04925-364	1	
36	BOLT, BLADE GUIDE ROLLER (RELUBE ONLY)	035412	1	
37	FITTING, 1/4-28 GREASE (RELUBE ONLY)	P05060	1	

2

Blade Guide Rollers & Arm

Blade Guide Assembly, Idle Side

- ¹ Blade Guide Assembly 035405 upgraded with new Block Weldment and Shaft to accommodate 7/16" adjustment hardware to improve durability (12/06) and non-greasable sealed blade guide roller bearings (1/04). See optional relube parts for greasable blade guide roller parts. Use kit 038971 to retrofit previous revisions with 7/16" adjustment hardware. New blade guide assembly available ([See Section 2.1](#)). Upgrade requires mounting arms, belt covers and LMS option. If sawmill not equipped with Board Return option, use kit 006328 to retrofit both blade guide assemblies. If sawmill equipped with Board Return option, use kit 006329 to retrofit. If sawmill not already equipped with LMS option, add kit LMS-A.
- ² Wear Block 052367 available 10/07 and provided as standard 4/09. EZ-Glide Block 036247 available for customers who prefer this block.
- ³ Use two Blade Lube Fittings 033479 if sawmill is equipped with LubeMizer blade lube system. These fittings are supplied with the LMS option.
- ⁴ Mount Shaft 035427, Adjuster Block 035408, 3/8" Set Screws F05007-162 & 3/8" Jam Nuts F05010-22 replaced with 7/16" adjustment hardware. Mount Shaft 035427 & Adjuster Block 035408 no longer available. Use kit 038971 to retrofit original parts.
- ⁵ Lower jam nut F05010-38 replaced with hex nut F05010-202 (3/07).
- ⁶ Stainless Set Screw replaces Zinc plated screw F05007-213 used prior to 6/07 to eliminate screw shearing.
- ⁷ Bearing must be modified for use with relube roller assemblies. Remove one seal from each bearing, place open sides facing each other and place spacer 035411 between bearings.

2.3 Blade Guide Assembly, Idle Side

LT30HD
LT40HD

Rev. H9.00 - J5.07
Rev. H9.00 - J6.08

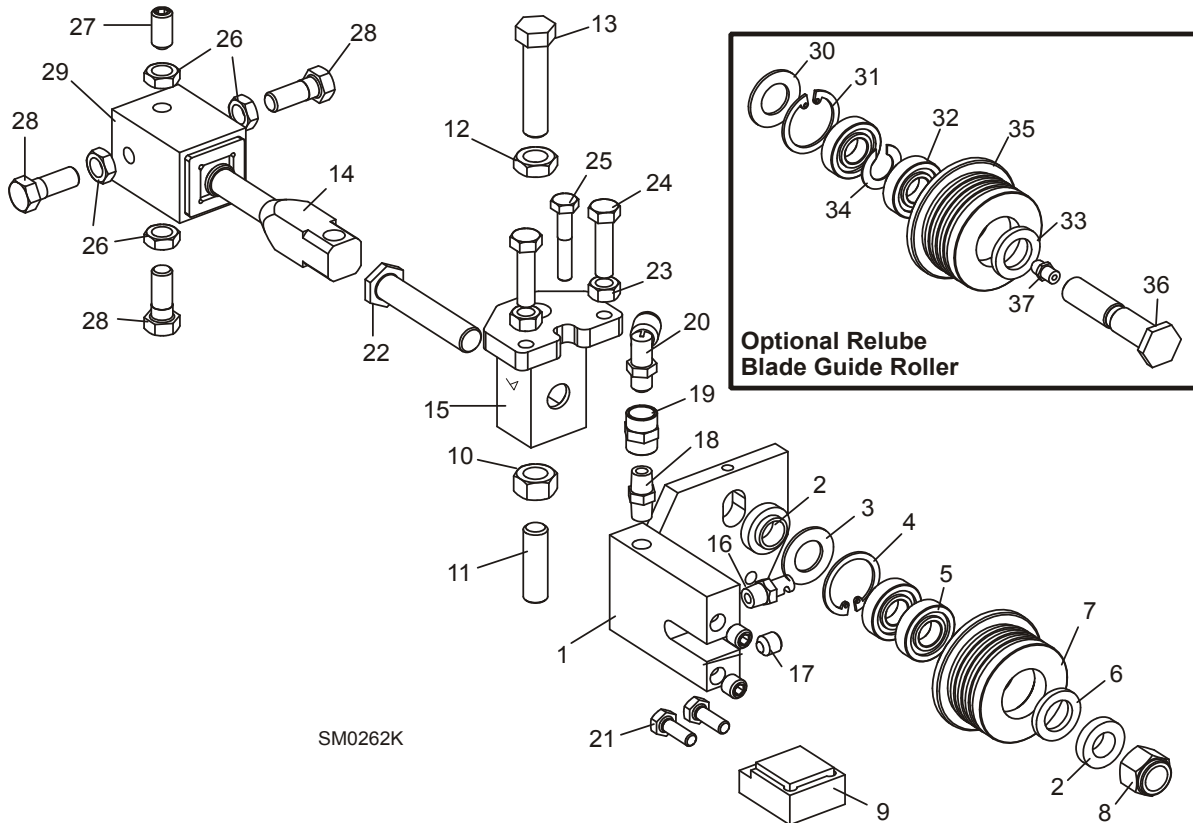

REF	DESCRIPTION (◆ Indicates Parts Available In Assemblies Only)	PART #	QTY.
	ROLLER/BLOCK ASSEMBLY, IDLE SIDE (OUTER)	035405 ¹	1
1	Nozzle Block Weldment, Idle Side	035404	1
2	Spacer, .510 x .937 x .34	S04253	2
	Roller Assembly, Blade Guide	A04925	1
	Bearing Kit, Blade Guide Rebuild	K07079	1
3	Washer, 5/8" White Felt	P04252	1
4	Ring, 1 1/8" Interior Retaining	F04254-1	1
5	Bearing, R8-2RS Blade Guide	015975	2
6	Washer, 5/8" Gray Felt	P06455	1
	Screw, 1/4-28 x 1/4" Socket Head Cup Point Set Black Oxide	F05005-105	1
	Instruction Sheet, Blade Guide Rebuild	057407-1507	1
7	Roller, Flanged Blade Guide	S04250	1
	Instruction Sheet, Blade Guide Roller Replacement	A04925-364	1
8	Nut, 1/2-20 Nylon Hex Lock	F05010-15	1

2

Blade Guide Rollers & Arm

Blade Guide Assembly, Idle Side

9	Block Assembly, 1 1/4" Blade EZ-Glide Wear	036247 ²	1	
	Block, 1 1/4" Blade Guide Wear	052367 ²	1	
	Shaft Kit, Blade Guide Adjust Retrofit	038971 ³	1	
10	Nut, 7/16-20 Hex	F05010-202 ⁴	1	
11	Screw, 7/16-20 x 1 1/2" Socket Head Cup Point Stainless Steel	F05007-217 ⁵	1	
12	Nut, 7-16-20 Hex Jam	F05010-38	1	
13	Bolt, 7/16-20 x 2" Hex Head Full Thread Grade 8	F05007-215	1	
14	Shaft, Blade Guide Mount	054966	1	
15	Block Weldment, Roller Guide Adjuster	054969	1	
16	Nozzle, Blade Water Lube Spray (For use with standard bottle water lube)	016637 ⁶	1	
17	Fitting, 1/8" NPT Socket Pipe Plug	P30127	3	
18	Fitting, 1/8" Dry Seal Nipple	P02764 ⁷	1	
19	Fitting, 1/8" FPT Coupling	P05748 ⁷	1	
20	Fitting, 1/8" MPT x 1/4" Tube 90° Elbow Swivel	P09736	1	
21	Bolt, 1/4-20 x 3/4" Hex Head Grade 5	F05005-123	2	
22	Bolt, Blade Guide Roller	036374	1	
23	Nut, 5/16-24 Hex	F05010-28	2	
24	Bolt, 5/16-24 x 1 1/4" Hex Head Full Thread Grade 5	F05006-107	2	
25	Bolt, 1/4-28 x 1 1/2" Hex Head Grade 5	F05005-143	1	
	SHIM, .008" CERAMIC INSERT SPACER	035248	1	
26	NUT, 3/8-24 HEX JAM	F05010-22	4	
27	SCREW, 3/8-24 X 3/4" STAINLESS STEEL SOCKET HEAD FLAT POINT	F05007-95	1	
28	BOLT, 3/8-24 X 1" STAINLESS STEEL HEX HEAD	F05007-99 ⁸	3	
29	TUBE, BLADE GUIDE MOUNT (See Section 2.4)	W08159	1	
	ROLLER ASSEMBLY, BLADE GUIDE RELUBE (OPTIONAL)	016568 ¹	1	
	Bearing Kit, Relube Blade Guide Rebuild	057407	1	
30	Washer, 5/8" White Felt	P04252	1	
31	Ring, 1 1/8" Interior Retaining	F04254-1	1	
32	Bearing, R8-2RS Blade Guide	015975 ⁹	2	◆
33	Washer, 5/8" Gray Felt	P06455	1	
34	Spacer, Blade Guide Bearing	035411	1	
	Instruction Sheet, Blade Guide Rebuild	057407-1507	1	
35	Roller, Flanged Blade Guide (Relube)	035426	1	◆
	Instruction Sheet, Blade Guide Roller Replacement	A04925-364	1	
36	BOLT, BLADE GUIDE ROLLER (RELUBE ONLY)	035412	1	
37	FITTING, 1/4-28 GREASE (RELUBE ONLY)	P05060	1	

¹ Blade Guide Assembly 035405 upgraded with new Block Weldment and Shaft to accommodate 7/16" adjustment hardware to improve durability (12/06). Use kit 038971 to retrofit previous revisions. New blade guide assembly available ([See Section 2.1](#)). Upgrade requires mounting arms, belt covers and LMS option. If sawmill not equipped with Board Return option, use kit 006328 to retrofit both blade guide assemblies. If sawmill equipped with Board Return option, use kit 006329 to retrofit. If sawmill not already equipped with LMS option, add kit LMS-A.

² Wear Block 052367 available 10/07 and provided as standard 4/09. Use to replace ceramic guide block 035222, screw F05004-71 & mount block 035235 originally supplied. EZ-Glide Block 036247 available for customers who prefer this block.

-
- ³ Mount Shaft 035427, Adjuster Block 035408, 3/8" Set Screws F05007-162 & 3/8" Jam Nuts F05010-22 replaced with 7/16" adjustment hard ware. Mount Shaft 035427 & Adjuster Block 035408 no longer available. Use kit 038971 to retrofit original parts.
- ⁴ Lower jam nut F05010-38 replaced with hex nut F05010-202 (3/07).
- ⁵ Stainless Set Screw replaces Zinc plated screw F05007-213 used prior to 6/07 to eliminate screw shearing.
- ⁶ Use two Blade Lube Fittings 033479 if sawmill is equipped with LubeMizer blade lube system. These fittings are supplied with the LMS option.
- ⁷ Fittings added to raise water lube hose to eliminate interference with blade guide arm (LT30HD Rev. J4.00 and LT40HD Rev. J5.00).
- ⁸ Hex head bolts replace F05007-95 set screws originally supplied prior to LT30HD Rev. J4.00 and LT40HD Rev. J5.00.
- ⁹ Bearing must be modified for use with relube roller assemblies. Remove one seal from each bearing, place open sides facing each other and place spacer 035411 between bearings.

2 Blade Guide Rollers & Arm

Blade Guide Assembly, Idle Side

2.4 Blade Guide Assembly, Idle Side

LT30HD
LT40HD

Rev. G1.00 - H8.01
Rev. G1.00 - H8.01

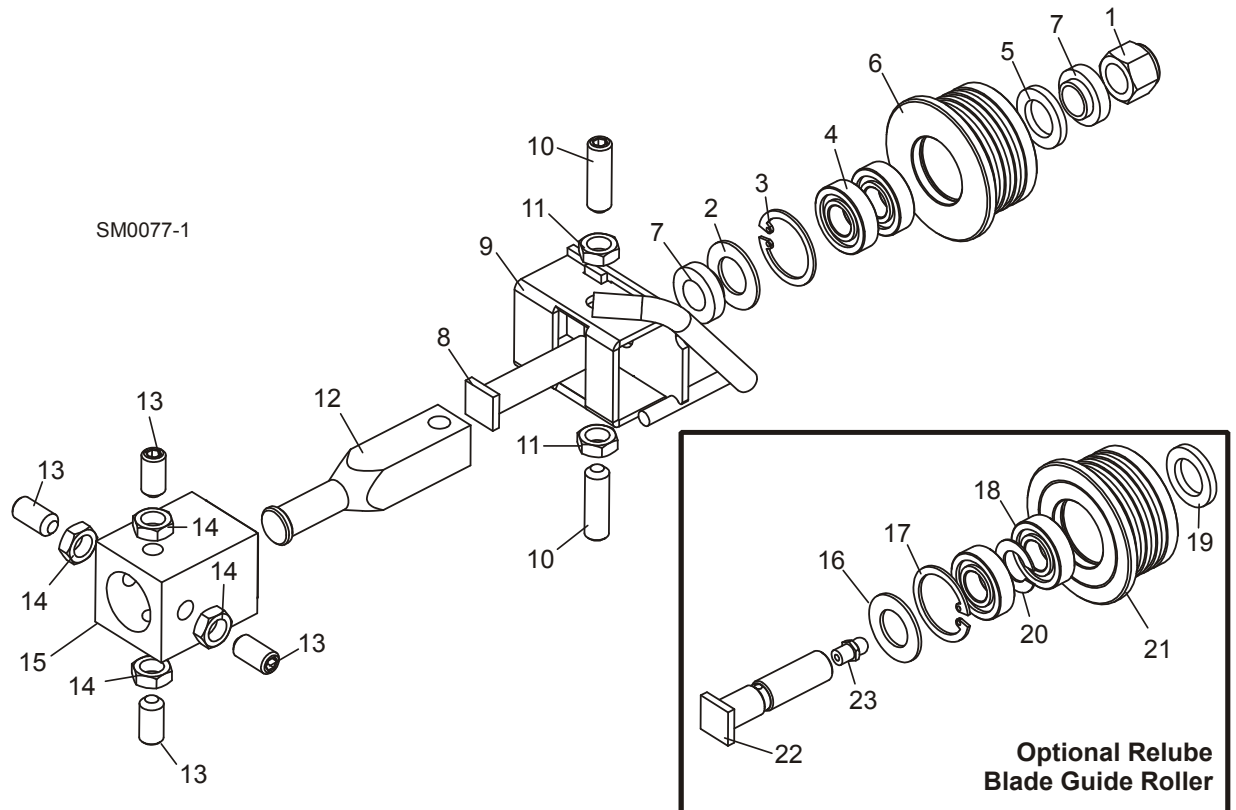

REF	DESCRIPTION (◆ Indicates Parts Available In Assemblies Only)	PART #	QTY.	
	BLADE GUIDE ASSEMBLY, COMPLETE IDLE SIDE	A08197 ¹	1	
1	Nut, 1/2-20 Nylon Hex Lock	F05010-15	1	
	Roller Assembly, Blade Guide	A04925	1	
	Bearing Kit, Blade Guide Rebuild	K07079	1	
2	Washer, 5/8" White Felt	P04252	1	
3	Ring, 1 1/8" Interior Retaining	F04254-1	1	
4	Bearing, R8-2RS Blade Guide	015975	2	◆
5	Washer, 5/8" Gray Felt	P06455	1	
	Screw, 1/4-28 x 1/4" Socket Head Cup Point Set Black Oxide	F05005-105	1	
	Instruction Sheet, Blade Guide Rebuild	057407-1507	1	
6	Roller, Flanged Blade Guide	S04250	1	◆
	Instruction Sheet, Blade Guide Roller Replacement	A04925-364	1	
7	Spacer, Blade Guide	S04253	2	
8	Bolt, Blade Guide Roller	036373	1	

9	Bracket, Blade Guide Idle Side With Water Tube	W08495	1	
10	Screw, 3/8-24 X 1 1/4" Stainless Steel Socket Head Flat Point	F05007-96	2	
11	Nut, 3/8-24 Jam	F05010-22	2	
12	Shaft, Blade Guide Adjustment	S08196	1	
13	SCREW, 3/8-24 X 3/4" STAINLESS STEEL SOCKET HEAD FLAT POINT	F05007-95	4	
14	NUT, 3/8-24 JAM	F05010-22	4	
15	TUBE, BLADE GUIDE MOUNT (See Section 2.10)	W08159	1	
	ROLLER ASSEMBLY, BLADE GUIDE RELUBE (OPTIONAL)	016568	1	
	Bearing Kit, Relube Blade Guide Rebuild	057407	1	
16	Washer, 5/8" White Felt	P04252	1	
17	Ring, 1 1/8" Interior Retaining	F04254-1	1	
18	Bearing, R8-2RS Blade Guide	015975 ²	2	◆
19	Washer, 5/8" Gray Felt	P06455	1	
20	Spacer, Blade Guide Bearing	035411	1	
	Instruction Sheet, Blade Guide Rebuild	057407-1507	1	
21	Roller, Flanged Blade Guide (Relube)	035426	1	◆
	Instruction Sheet, Blade Guide Roller Replacement	A04925-364	1	
22	BOLT, BLADE GUIDE ROLLER (RELUBE ONLY)	S08192	1	
23	FITTING, 1/4-28 GREASE (RELUBE ONLY)	P05060	1	

¹ Complete blade guide assembly A08197 includes roller with non-greaseable bearings A04925. See optional parts for Relube guide assemblies. New high-performance blade guide assemblies available. Dual-block assembly available for Rev. H8.00 and later with bolt-on drive-side blade guide ([See Section 2.1](#)). If sawmill not equipped with Board Return option, use kit 006328 to retrofit both blade guide assemblies. If sawmill equipped with Board Return option, use kit 006329 to retrofit. Single-block assembly available for sawmills prior to Rev. H8.00 without bolt-on drive-side blade guide ([See Section 2.2](#)). Order blade guide assemblies 035405, 035410, instruction sheet 016567-941 and blade guide arm W10005 separately to update (replaces upgrade kit 016567 no longer available). Either high-performance blade guide system requires the LubeMizer option. If sawmill not already equipped with LMS option, add kit LMS-ALMS-RA.

² Bearing must be modified for use with relube roller assemblies. Remove one seal from each bearing, place open sides facing each other and place spacer 035411 between bearings.

2 Blade Guide Rollers & Arm

Blade Guide Assembly, Drive Side

2.5 Blade Guide Assembly, Drive Side

LT30HD
LT40HD

Retrofit
Retrofit

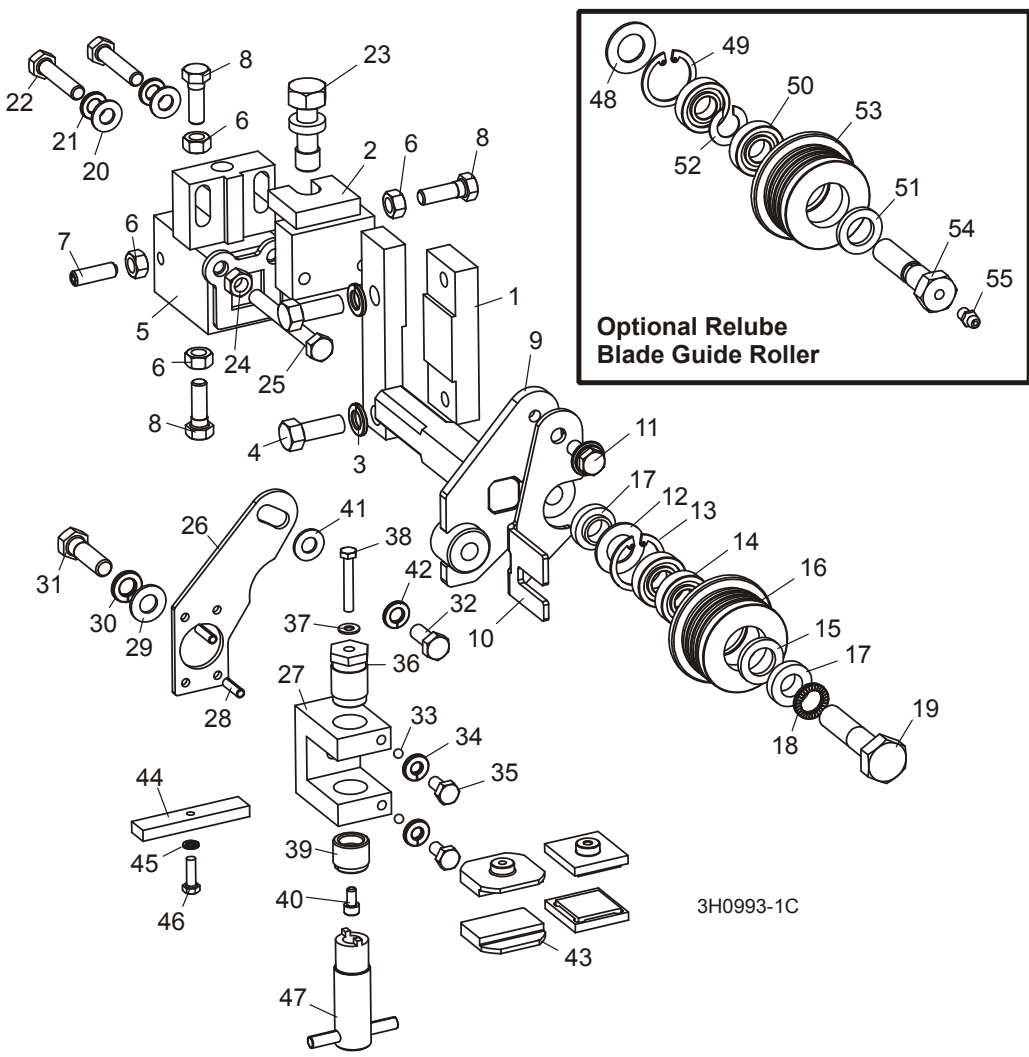

REF	DESCRIPTION (◆ Indicates Parts Available In Assemblies Only)	PART #	QTY.
1	BLOCK, BOLT ON BLADE GUIDE MOUNT	016548	1
2	BRACKET WELDMENT, INNER BLADE GUIDE MOUNT	003964	1
3	WASHER, 3/8" SPLIT LOCK	F05011-4	2
4	BOLT, 3/8-16 X 1" HEX HEAD	F05007-7	2
	GUIDE ASSEMBLY, DRIVE SIDE BLADE ROLLER	003905	1
	Block Assembly, Blade Guide Mount	003910	1
5	Block Weldment, Blade Guide Mount	003911	1
6	Nut, 5/16-18 Hex	F05010-17	4

Blade Guide Rollers & Arm

Blade Guide Assembly, Drive Side

2

7	Screw, 5/16-18 x 1" Socket Head Flat Point Stainless Steel Set	F05006-122	1	
8	Bolt, 5/16-18 x 1" Hex Head Stainless Steel	F05006-88	3	
9	Shaft Weldment, Drive Side Guide	003913	1	
10	Plate, Blade Guide Deflector	003916	1	
11	Bolt, 5/16-18 x 3/4" Hex Head w/Flat & Lock Washer	F05006-101	1	
	Roller Assembly, Blade Guide (standard)	A04925	1	
	Bearing Kit, Blade Guide Rebuild	K07079	1	
12	Washer, 5/8" White Felt	P04252	1	
13	Ring, 1 1/8" Interior Retaining	F04254-1	1	
14	Bearing, R8-2RS Blade Guide	015975	2	◆
15	Washer, 5/8" Gray Felt	P06455	1	
	Screw, 1/4-28 x 1/4" Socket Head Cup Point Set Black Oxide	F05005-105	1	
	Instruction Sheet, Blade Guide Rebuild	057407-1507	1	
16	Roller, Flanged Blade Guide	S04250	1	◆
	Instruction Sheet, Blade Guide Roller Replacement	A04925-364	1	
17	Spacer, Blade Guide	S04253	2	
18	Washer, 1/2" Nord-Lock	F05011-125 ¹	1	
19	Bolt, 1/2-13 x 2 1/4" Hex Head Grade 5	F05008-10	1	
20	Washer, 5/16" SAE Flat	F05011-17	2	
21	Washer, 5/16" Split Lock	F05011-13	2	
22	Bolt, 5/16-18 x 1 1/2" Hex Head	F05006-76	2	
23	Bolt, Blade Guide Vertical Adjustment	035656	1	
24	Nut, 5/16-18 Hex	F05010-17	1	
25	Bolt, 5/16-18 x 2 1/4" Hex Head Full Thread	F05006-16	1	
	BLOCK ASSEMBLY, DRIVE SIDE BLADE GUIDE	003927	1	
26	Plate, Block Tilt Adjustment	003915	1	
27	Block, Guide Block Mount	003909	1	
28	Pin, 3/16" x 5/8" Roll	F05012-22	2	
29	Washer, 3/8" SAE Flat	F05011-3	1	
30	Washer, 3/8" Split Lock	F05011-4	1	
31	Bolt, 3/8-16 x 1 1/4" Hex Head Grade 5	F05007-123	1	
32	Bolt, 5/16-18 x 3/4" Hex Head w/Flat & Lock Washer	F05006-101	1	
33	Ball, 3/16" Dia. Nylon	003914	2	
34	Washer, 1/4" Split Lock	F05011-14	2	
35	Bolt, 1/4-20 x 1/2" Hex Head	F05005-15	2	
36	Bolt, Blade Guide Block Mount	003994	1	
37	Washer, #10 Brass	042867	1	
38	Bolt, #10-32 x 1 1/4" Hex Head Stainless Steel	F05004-240	1	
39	Screw, Lower Block Adjustment	044057	1	
40	Screw, #10-32 x 3/8" Socket Head Stainless Steel	F05004-200	1	
41	BLOCK, BLADE GUIDE WEAR (STANDARD FOR 1 1/4" BLADES)	052355 ²	2	
	BLOCK ASSEMBLY, 1" SQ. EZ-GLIDE WEAR	036347 ²	2	
42	BLOCK, BLADE GUIDE ALIGNMENT	035799	1	

2

Blade Guide Rollers & Arm*Blade Guide Assembly, Drive Side*

43	WASHER, #10 SPLIT LOCK	F05011-20	1	
44	SCREW, #10-32 X 5/8" HEX HEAD	F05004-152	1	
45	ADJUSTMENT TOOL, LOWER GUIDE BLOCK	044064	1	
	SHIM, .008" BLADE GUIDE BLOCK SPACER	035248	1	
	ROLLER ASSEMBLY, BLADE GUIDE RELUBE (OPTIONAL)	016568	1	
	Bearing Kit, Relube Blade Guide Rebuild	057407	1	
46	Washer, 5/8" White Felt	P04252	1	
47	Ring, 1 1/8" Interior Retaining	F04254-1	1	
48	Bearing, R8-2RS Blade Guide	015975 ³	2	◆
49	Washer, 5/8" Gray Felt	P06455	1	
50	Spacer, Blade Guide Bearing	035411	1	
	Instruction Sheet, Blade Guide Rebuild	057407-1507	1	
51	Roller, Flanged Blade Guide (Relube)	035426	1	◆
	Instruction Sheet, Blade Guide Roller Replacement	A04925-364	1	
52	BOLT, BLADE GUIDE ROLLER (RELUBE ONLY)	036161	1	
53	FITTING, 1/4-28 GREASE (RELUBE ONLY)	P05060	1	

¹ Nord-Lock Washer F05011-125 replaced Split Lock Washer F05011-9 to prevent loosening due to vibration (12/09).

² 052355 blocks for use with 1 1/4" blade provided as standard equipment. EZ-Glide blocks 036347 are available for customers who prefer this block.

³ Bearing must be modified for use with relube roller assemblies. Remove one seal from each bearing, place open sides facing each other and place spacer 035411 between bearings.

2.6 Blade Guide Assembly, Drive Side

LT30HD
LT40HD

Rev. J6.00 - J7.00
Rev. J7.00 - J8.00

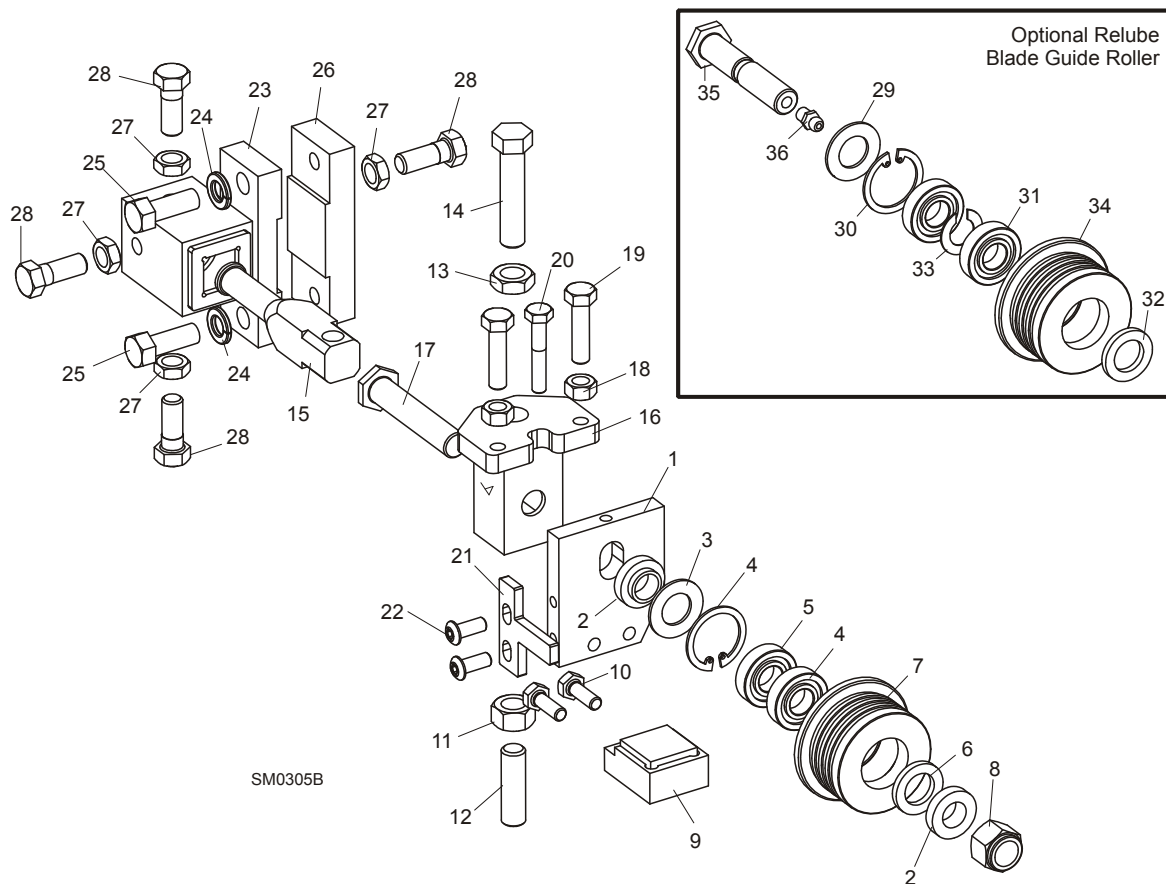

SM0305B

REF	DESCRIPTION (◆ Indicates Parts Available In Assemblies Only)	PART #	QTY.	
	ROLLER/BLOCK ASSEMBLY, DRIVE SIDE (INNER)	035410 ¹	1	
1	Plate, Blade Guide Back Mounting	035409	1	
2	Spacer, .510 x .937 x .34	S04253	2	
	Roller Assembly, Blade Guide (standard)	A04925	1	
	Bearing Kit, Blade Guide Rebuild	K07079	1	
3	Washer, 5/8" White Felt	P04252	1	
4	Ring, 1 1/8" Interior Retaining	F04254-1	1	
5	Bearing, R8-2RS Blade Guide	015975	2	◆
6	Washer, 5/8" Gray Felt	P06455	1	
	Screw, 1/4-28 x 1/4" Socket Head Cup Point Set Black Oxide	F05005-105	1	
	Instruction Sheet, Blade Guide Rebuild	057407-1507	1	
7	Roller, Flanged Blade Guide	S04250	1	◆

2

Blade Guide Rollers & Arm*Blade Guide Assembly, Drive Side*

	Instruction Sheet, Blade Guide Roller Replacement	A04925-364	1	
8	Nut, 1/2-20 Nylon Hex Lock	F05010-15	1	
9	Block Assembly, 1 1/4" Blade EZ-Glide Wear	036247 ²	1	
	Block, 1 1/4" Blade Guide Wear	052367 ²	1	
10	Bolt, 1/4-20 x 3/4" Hex Head Grade 5	F05005-123	2	
	Shaft Kit, Blade Guide Adjust Retrofit	038971 ³	1	
11	Nut, 7/16-20 Hex	F05010-202 ⁴	1	
12	Screw, 7/16-20 x 1 1/2" Socket Head Cup Point Stainless Steel	F05007-217 ⁵	1	
13	Nut, 7-16-20 Hex Jam	F05010-38	1	
14	Bolt, 7/16-20 x 2" Hex Head Full Thread Grade 8	F05007-215	1	
15	Shaft, Blade Guide Mount	054966	1	
16	Block Weldment, Roller Guide Adjuster	054969	1	
17	Bolt, Blade Guide Roller	036374	1	
18	Nut, 5/16-24 Hex	F05010-28	2	
19	Bolt, 5/16-24 x 1 1/4" Hex Head Full Thread Stainless	F05006-107	2	
20	Bolt, 1/4-28 x 1 1/2" Hex Head Stainless	F05005-143	1	
21	Guard, Drive Roller	035490	1	
22	Screw, 1/4-20 x 5/8" Button Head Socket Cap Grade 2	F05005-128	2	
	SHIM, .008" BLADE GUIDE BLOCK SPACER	035248	1	
	BLOCK KIT, DRIVE SIDE BLADE GUIDE BOLT ON	016566	1	
23	Block Weldment, Drive Side Blade Guide Bolt On	016550	1	
24	Washer, 3/8" Split Lock	F05011-4	2	
25	Bolt, 3/8-16 x 1" Hex Head	F05007-7	2	
26	Block, Bolt On Blade Guide Mount	016548	1	
27	Nut, 3/8-24 Jam	F05010-22	4	
28	Bolt, 3/8-24 X 1" Stainless Steel Hex Head	F05007-99	4	
	ROLLER ASSEMBLY, BLADE GUIDE RELUBE (OPTIONAL)	016568	1	
	Bearing Kit, Relube Blade Guide Rebuild	057407	1	
29	Washer, 5/8" White Felt	P04252	1	
30	Ring, 1 1/8" Interior Retaining	F04254-1	1	
31	Bearing, R8-2RS Blade Guide	015975 ⁶	2	◆
32	Washer, 5/8" Gray Felt	P06455	1	
33	Spacer, Blade Guide Bearing	035411	1	
	Instruction Sheet, Blade Guide Rebuild	057407-1507	1	
34	Roller, Flanged Blade Guide (Relube)	035426	1	◆
	Instruction Sheet, Blade Guide Roller Replacement	A04925-364	1	
35	BOLT, BLADE GUIDE ROLLER (RELUBE ONLY)	035412	1	
36	FITTING, 1/4-28 GREASE (RELUBE ONLY)	P05060	1	

- ¹ Blade Guide Assembly 035410 upgraded with new Block Weldment and Shaft to accommodate 7/16" adjustment hardware to improve durability (12/06) and non-greasable sealed blade guide roller bearings (1/04). See optional relube parts for greasable blade guide roller parts. Use kit 038971 to retrofit previous revisions with 7/16" adjustment hardware. New blade guide assembly available ([See Section 2.5](#)). Upgrade requires mounting arms, belt covers and LMS option. If sawmill not equipped with Board Return option, use kit 006328 to retrofit both blade guide assemblies. If sawmill equipped with Board Return option, use kit 006329 to retrofit. If sawmill not already equipped with LMS option, add kit LMS-A.
- ² Wear Block 052367 available 10/07 and provided as standard 4/09. EZ-Glide Block 036247 available for customers who prefer this block.
- ³ Mount Shaft 035427, Adjuster Block 035408, 3/8" Set Screws F05007-162 & 3/8" Jam Nuts F05010-22 replaced with 7/16" adjustment hardware. Mount Shaft 035427 & Adjuster Block 035408 no longer available. Use kit 038971 to retrofit original parts.
- ⁴ Lower jam nut F05010-38 replaced with hex nut F05010-202 (3/07).
- ⁵ Stainless Set Screw replaces Zinc plated screw F05007-213 used prior to 6/07 to eliminate screw shearing.
- ⁶ Bearing must be modified for use with relube roller assemblies. Remove one seal from each bearing, place open sides facing each other and place spacer 035411 between bearings.

2 Blade Guide Rollers & Arm

Blade Guide Assembly, Drive Side

2.7 Blade Guide Assembly, Drive Side

LT30HD
LT40HD

Rev. H9.00 - J5.07
Rev. H9.00 - J6.08

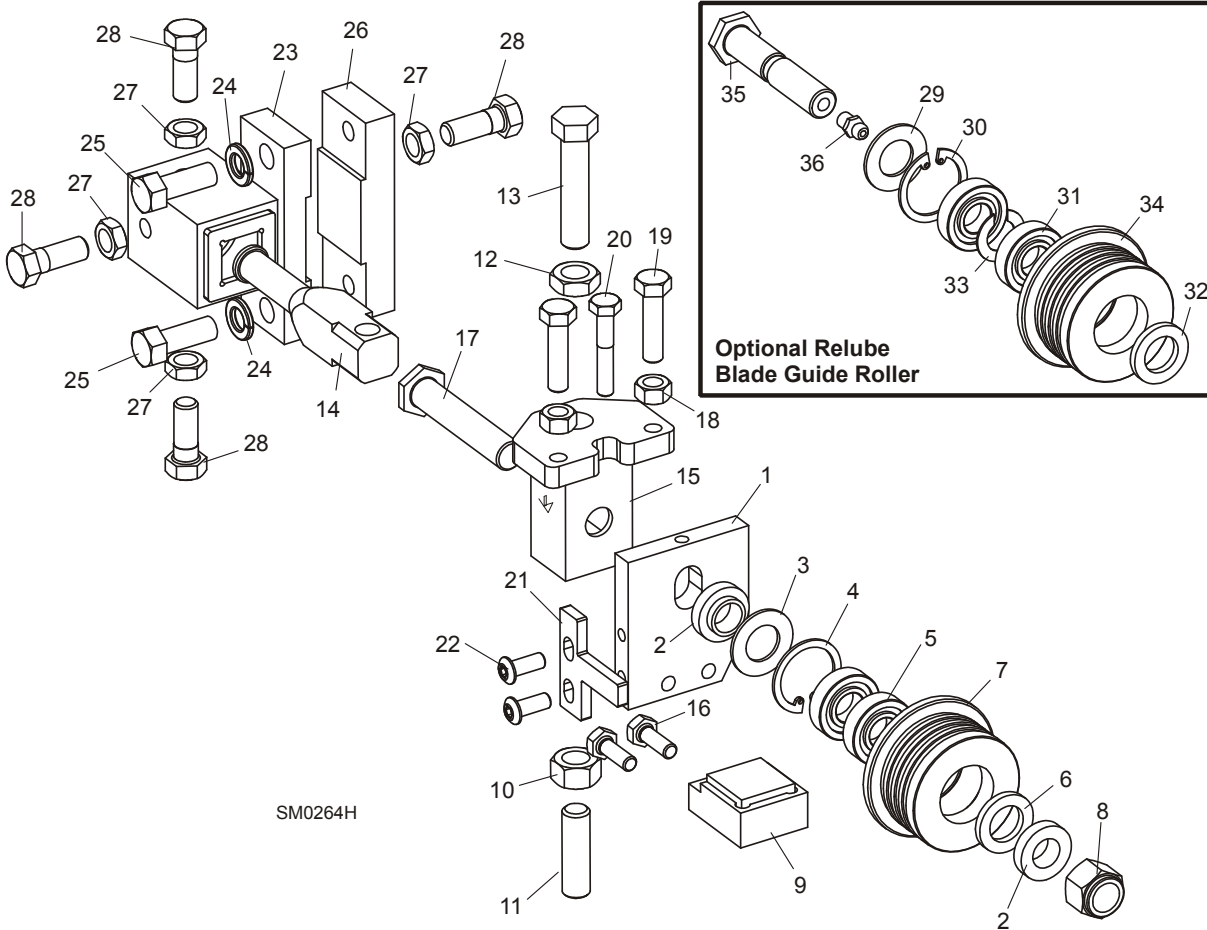

SM0264H

REF	DESCRIPTION (◆ Indicates Parts Available In Assemblies Only)	PART #	QTY.	
	ROLLER/BLOCK ASSEMBLY, DRIVE SIDE (INNER)	035410 ¹	1	
1	Plate, Blade Guide Back Mounting	035409	1	
2	Spacer, .510 x .937 x .34	S04253	2	
	Roller Assembly, Blade Guide	A04925	1	
	Bearing Kit, Blade Guide Rebuild	K07079	1	
3	Washer, 5/8" White Felt	P04252	1	
4	Ring, 1 1/8" Interior Retaining	F04254-1	1	
5	Bearing, R8-2RS Blade Guide	015975	2	◆
6	Washer, 5/8" Gray Felt	P06455	1	
	Screw, 1/4-28 x 1/4" Socket Head Cup Point Set Black Oxide	F05005-105	1	
	Instruction Sheet, Blade Guide Rebuild	057407-1507	1	
7	Roller, Flanged Blade Guide	S04250	1	◆

Blade Guide Rollers & Arm

Blade Guide Assembly, Drive Side

2

	Instruction Sheet, Blade Guide Roller Replacement	A04925-364	1	
8	Nut, 1/2-20 Nylon Hex Lock	F05010-15	1	
9	Block Assembly, 1 1/4" Blade EZ-Glide Wear	036247 ²	1	
	Block, 1 1/4" Blade Guide Wear	052367 ²	1	
	Shaft Kit, Blade Guide Adjust Retrofit	038971 ³	1	
10	Nut, 7/16-20 Hex	F05010-202 ⁴	1	
11	Screw, 7/16-20 x 1 1/2" Socket Head Cup Point Stainless Steel	F05007-217 ⁵	1	
12	Nut, 7-16-20 Hex Jam	F05010-38	1	
13	Bolt, 7/16-20 x 2" Hex Head Full Thread Grade 8	F05007-215	1	
14	Shaft, Blade Guide Mount	054966	1	
15	Block Weldment, Roller Guide Adjuster	054969	1	
16	Bolt, 1/4-20 x 3/4" Hex Head Grade 5	F05005-123	2	
17	Bolt, Blade Guide Roller	036374	1	
18	Nut, 5/16-24 Hex	F05010-28	2	
19	Bolt, 5/16-24 x 1 1/4" Hex Head Full Thread Stainless	F05006-107	2	
20	Bolt, 1/4-28 x 1 1/2" Hex Head Stainless	F05005-143	1	
21	Guard, Drive Roller	035490	1	
22	Screw, 1/4-20 x 55/8" Button Head Socket Cap Grade 2	F05005-128	2	
	SHIM, .008" BLADE GUIDE BLOCK SPACER	035248	1	
	BLOCK KIT, DRIVE SIDE BLADE GUIDE BOLT ON	016566	1	
23	Block Weldment, Drive Side Blade Guide Bolt On	016550	1	
24	Washer, 3/8" Split Lock	F05011-4	2	
25	Bolt, 3/8-16 x 1" Hex Head	F05007-7	2	
26	Block, Bolt On Blade Guide Mount	016548	1	
27	Nut, 3/8-24 Jam	F05010-22	4	
28	Bolt, 3/8-24 X 1" Stainless Steel Hex Head	F05007-99 ⁶	4	
	ROLLER ASSEMBLY, BLADE GUIDE RELUBE (OPTIONAL)	016568	1	
	Bearing Kit, Relube Blade Guide Rebuild	057407	1	
29	Washer, 5/8" White Felt	P04252	1	
30	Ring, 1 1/8" Interior Retaining	F04254-1	1	
31	Bearing, R8-2RS Blade Guide	015975 ⁷	2	◆
32	Washer, 5/8" Gray Felt	P06455	1	
33	Spacer, Blade Guide Bearing	035411	1	
	Instruction Sheet, Blade Guide Rebuild	057407-1507	1	
34	Roller, Flanged Blade Guide (Relube)	035426	1	◆
	Instruction Sheet, Blade Guide Roller Replacement	A04925-364	1	
35	BOLT, BLADE GUIDE ROLLER (RELUBE ONLY)	035412	1	
36	FITTING, 1/4-28 GREASE (RELUBE ONLY)	P05060	1	

¹ Blade Guide Assembly 035410 upgraded with new Block Weldment and Shaft to accommodate 7/16" adjustment hardware to improve durability (12/06). Use kit 038971 to retrofit previous revisions. New blade guide assembly available ([See Section 2.5](#)). Upgrade requires mounting arms, belt covers and LMS option. If sawmill not equipped with Board Return option, use kit 006328 to retrofit both blade guide assemblies. If sawmill equipped with Board Return option, use kit 006329 to retrofit. If sawmill not already equipped with LMS option, add kit LMS-A.

2

Blade Guide Rollers & Arm

Blade Guide Assembly, Drive Side

- ² Wear Block 052367 available 10/07 and provided as standard 4/09. Use to replace ceramic guide block 035222, screw F05004-71 & mount block 035235 originally supplied. EZ-Glide Block 036247 available for customers who prefer this block.
- ³ Mount Shaft 035427, Adjuster Block 035408, 3/8" Set Screws F05007-162 & 3/8" Jam Nuts F05010-22 replaced with 7/16" adjustment hard ware. Mount Shaft 035427 & Adjuster Block 035408 no longer available. Use kit 038971 to retrofit original parts.
- ⁴ Lower jam nut F05010-38 replaced with hex nut F05010-202 (3/07).
- ⁵ Stainless Set Screw replaces Zinc plated screw F05007-213 used prior to 6/07 to eliminate screw shearing.
- ⁶ Hex head bolts replace F05007-95 set screws originally supplied prior to LT30HD Rev. J4.00 and LT40HD Rev. J5.00.
- ⁷ Bearing must be modified for use with relube roller assemblies. Remove one seal from each bearing, place open sides facing each other and place spacer 035411 between bearings.

2.8 Blade Guide Assembly, Drive Side

LT30HD
LT40HD

Rev. G1.00 - H8.01
Rev. G1.00 - H8.01

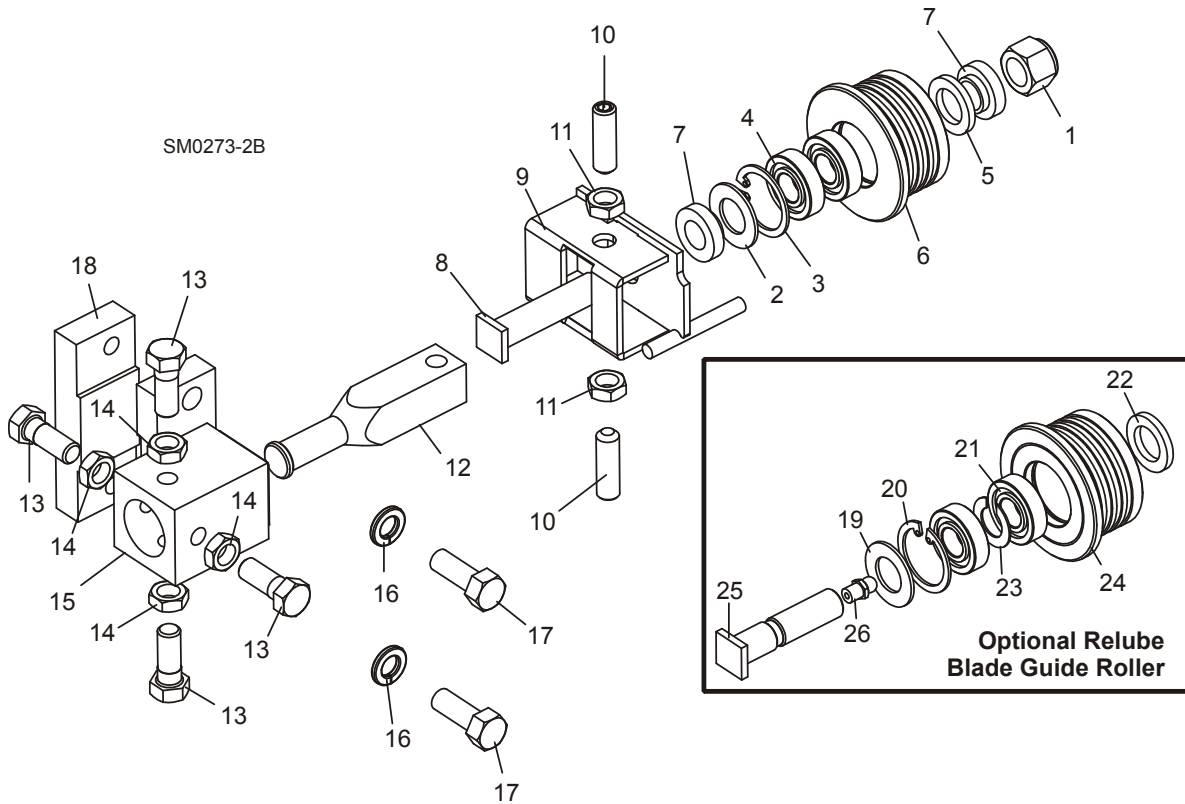

REF	DESCRIPTION (◆ Indicates Parts Available In Assemblies Only)	PART #	QTY.	
	BLADE GUIDE ASSEMBLY, COMPLETE DRIVE SIDE	A08191 ¹	1	
1	Nut, 1/2-20 Hex Nylon Lock	F05010-15	1	
	Roller Assembly, Blade Guide	A04925	1	
	Bearing Kit, Blade Guide Rebuild	K07079	1	
2	Washer, 5/8" White Felt	P04252	1	
3	Ring, 1 1/8" Interior Retaining	F04254-1	1	
4	Bearing, R8-2RS Blade Guide	015975	2	◆
5	Washer, 5/8" Gray Felt	P06455	1	
	Screw, 1/4-28 x 1/4" Socket Head Cup Point Set Black Oxide	F05005-105	1	
	Instruction Sheet, Blade Guide Rebuild	057407-1507	1	
6	Roller, Flanged Blade Guide	S04250	1	◆
	Instruction Sheet, Blade Guide Roller Replacement	A04925-364	1	
7	Spacer, Blade Guide	S04253	2	
8	Bolt, Blade Guide Roller	036373	1	
9	Bracket, Blade Guide Drive Side	W08482	1	
10	Screw, 3/8-24 X 1 1/4" Stainless Steel Socket Head Flat Point	F05007-96	2	

2

Blade Guide Rollers & Arm

Blade Guide Assembly, Drive Side

11	Nut, 3/8-24 Jam	F05010-22	2	
12	Shaft, Blade Guide Adjustment	S08196	1	
	BLOCK KIT, DRIVE SIDE BLADE GUIDE BOLT ON	016566 ²	1	
13	Screw, 3/8-24 X 3/4" Stainless Steel Socket Head Flat Point Set	F05007-99 ³	4	
14	Nut, 3/8-24 Jam	F05010-22	4	
15	Block Weldment, Drive Side Blade Guide Bolt On	016550	1	
16	Washer, 3/8" Split Lock	F05011-4	2	
17	Bolt, 3/8-16 x 1" Hex Head	F05007-7	2	
18	Block, Bolt On Blade Guide Mount	016548	1	
	ROLLER ASSEMBLY, BLADE GUIDE RELUBE (OPTIONAL)	016568	1	
	Bearing Kit, Relube Blade Guide Rebuild	057407	1	
19	Washer, 5/8" White Felt	P04252	1	
20	Ring, 1 1/8" Interior Retaining	F04254-1	1	
21	Bearing, R8-2RS Blade Guide	015975 ⁴	2	◆
22	Washer, 5/8" Gray Felt	P06455	1	
23	Spacer, Blade Guide Bearing	035411	1	
	Instruction Sheet, Blade Guide Rebuild	057407-1507	1	
24	Roller, Flanged Blade Guide (Relube)	035426	1	◆
	Instruction Sheet, Blade Guide Roller Replacement	A04925-364	1	
25	BOLT, BLADE GUIDE ROLLER (RELUBE ONLY)	S08192	1	
26	FITTING, 1/4-28 GREASE (RELUBE ONLY)	P05060	1	

¹ Complete blade guide assembly A08191 includes roller with non-greaseable bearings A04925. See optional parts for Relube guide assemblies. New high-performance blade guide assemblies available. Dual-block assembly available for Rev. H8.00 and later with bolt-on drive-side blade guide ([See Section 2.5](#)). If sawmill not equipped with Board Return option, use kit 006328 to retrofit both blade guide assemblies. If sawmill equipped with Board Return option, use kit 006329 to retrofit. Single-block assembly available for sawmills prior to Rev. H8.00 without bolt-on drive-side blade guide ([See Section 2.6](#)). Order blade guide assemblies 035405, 035410, instruction sheet 016567-941 and blade guide arm W10005 separately to update (replaces upgrade kit 016567 no longer available). Either high-performance blade guide system requires the LubeMizer option. If sawmill not already equipped with LMS option, add kit LMS-ALMS-RA.

² Bolt-On blade guide block replaces block welded to saw frame prior to Rev. H8.00. Bolt-On block is easier to replace when necessary. Previous revisions can be retrofitted (requires kit 016566).

³ Hex head bolts replace F05007-95 set screws originally supplied.

⁴ Bearing must be modified for use with relube roller assemblies. Remove one seal from each bearing, place open sides facing each other and place spacer 035411 between bearings.

2.9 Blade Guide Arm Drive Assembly

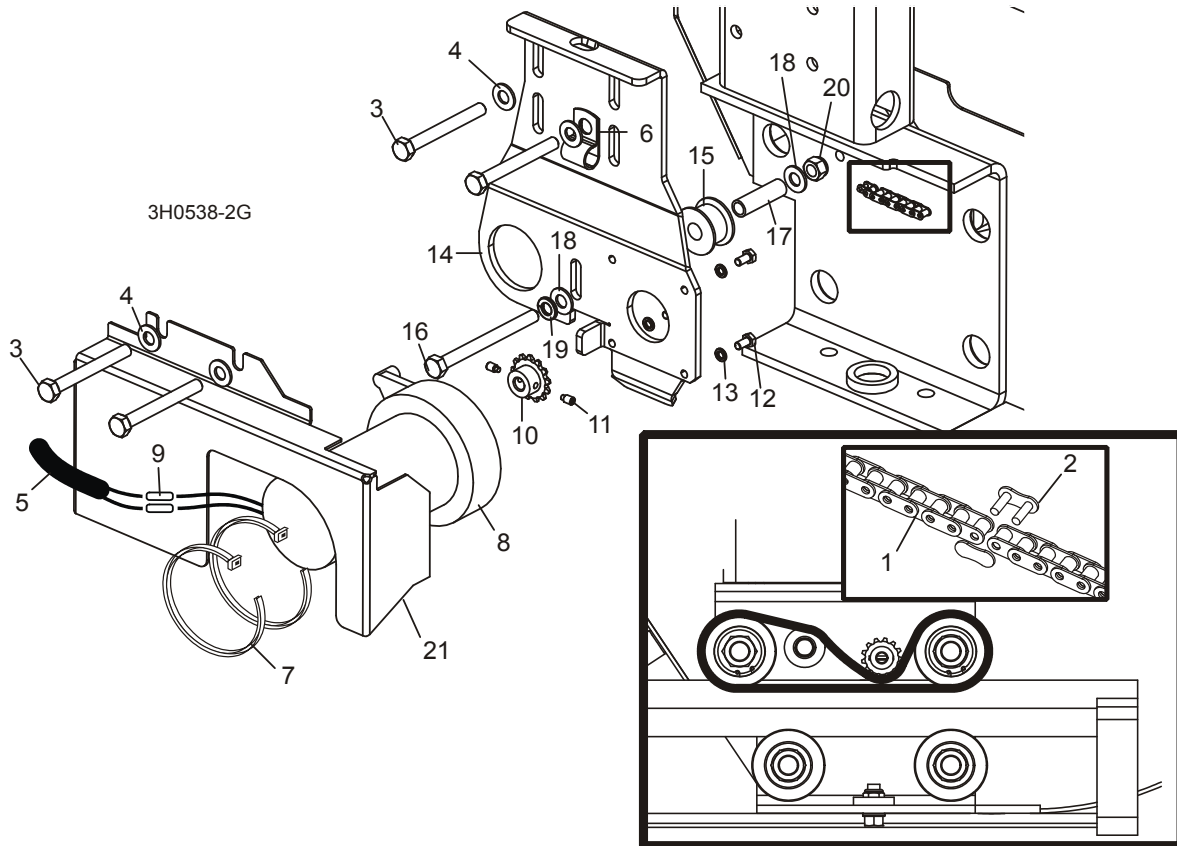

REF	DESCRIPTION (◆ Indicates Parts Available In Assemblies Only)	PART #	QTY.
1	CHAIN, #25 X 20 1/4"	P09984	1
2	LINK, #25 MASTER	P09983	1
3	BOLT, 5/16-18 X 2 3/4" HEX HEAD GRADE 5	F05006-28	4
4	WASHER, 5/16" SAE FLAT	F05011-17	4
5	TUBE, 3/8" X 1/2" NEOPRENE	R01897	2.5ft
6	CLAMP, 1/2" COATED EMT	P07584	2
7	WRAP, 1/4" X 6" TIE	F05089-1	2
	DRIVE ASSEMBLY, BLADE GUIDE ARM	015989 ¹	1
	Motor Assembly, Blade Guide Arm Replacement	A10353 ²	1
8	Motor, Blade Guide Arm 53:1 Gear	P09698-1	1
	Housing, Klauber Motor End	P12756	1
	Gear Kit, Klauber Motor Replacement	P12569	1
	Brush Kit, Gear Motor Replacement	P12800	1
	Shaft Kit, Klauber Gear Motor Replacement	009695	1
9	Connector, 14 Gauge Butt	F04875-1	2

2

Blade Guide Rollers & Arm Blade Guide Arm Drive Assembly

10	Sprocket, Gear Motor #25 14-Tooth	P09970 ³	1	
11	Screw, #10-24 x 1/4" Full Dog Point Socket Set	F05004-274	2	
12	Screw, #10-32 x 1/2" Hex Head	F05004-60	4	
13	Washer, #10 Split Lock	F05011-20	4	
	Instruction Sheet, Blade Guide Arm Motor	A10353-296	1	
14	Bracket, Blade Guide Arm Motor Mount	015939 ¹	1	
15	Roller, Blade Guide Arm Chain Idler	S09999	1	
16	Bolt, 5/16-18 X 3 1/2" Hex Head Full Thread	F05006-3	1	
17	Spacer, 5/16" I.D. X 1 1/2"	S09996	1	
18	Washer, 5/16" SAE Flat	F05011-17	2	
19	Washer, 5/16" Split Lock	F05011-13	1	
20	Nut, 5/16-18 Hex Nylon Lock	F05010-58 ⁴	1	
21	COVER, BLADE GUIDE ARM MOTOR	S11617	1	
	GUARD, BLADE GUIDE ARM (G.S. ONLY)	S12029	1	

¹ Replaces drive assembly A09974 on all 1997 models. New bracket 015939 replaces S09934 originally supplied until LT30HD/40HD Rev. G6.00. New bracket eliminates possible deformation of 3x5 sawframe tube when drive assembly bolts are tightened. Tab added to 015939 7/00 to provide a positive stop for the blade guide.

² Weather Boot 023720 removed LT30HD/40HD Rev. H2.00 because water could seep under boot and damage the motor. Boot was added on LT30HD/40HD Rev. G7.00.

³ Sprocket modified 6/11 with threaded holes to accept included set screws (replace 1/8" x 3/4" roll pin F05012-6).

⁴ Replaces F05010-6 Swaged Lock Nut supplied prior to 10/01 to prevent stripping of threads.

2.10 Blade Guide Arm

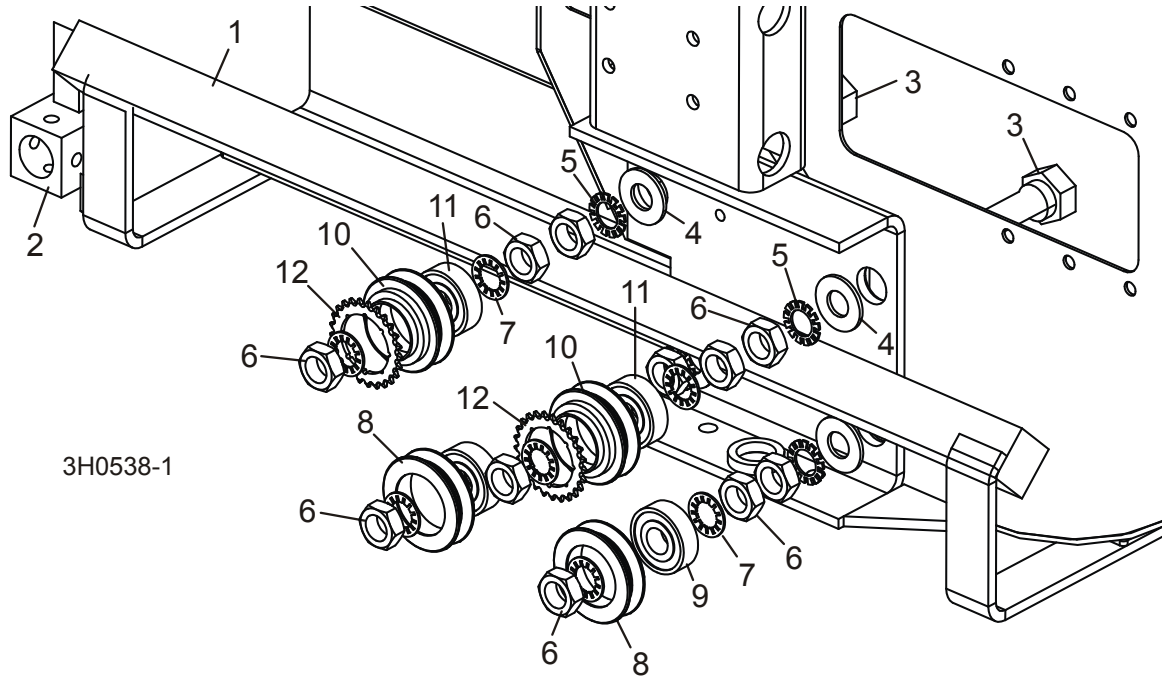

3H0538-1

REF	DESCRIPTION (◆ Indicates Parts Available In Assemblies Only)	PART #	QTY.	
1	BLADE GUIDE ARM WELDMENT (U.S. 28 5/8" [72.7 CM])	W10005	1	
	BLADE GUIDE ARM WELDMENT (G.S. 37 1/8" [94.2 CM])	W10429	1	
2	Tube, Blade Guide Mount (U.S. - Welded to Blade Guide Arm)	W08159	1	
	Tube, Blade Guide Mount (G.S. - Bolted to Blade Guide Arm)	W10426	1	
3	BOLT, BLADE GUIDE ARM ROLLER CAM	W09067	4	
4	WASHER, 5/8" SAE FLAT	F05011-5	4	
5	WASHER, 5/8" EXTERNAL STAR	F05011-26	4	
6	NUT, 5/8-18 HEX JAM	F05010-11	12	
7	WASHER, 5/8" INTERNAL STAR	F05011-25	8	
	ROLLER ASSEMBLY, BLADE GUIDE ARM WITH BEARING	A09059 ¹	2	
8	Roller, Blade Guide Arm V-Groove	S07989	1	◆
9	Bearing, 6203-2NSL 5/8" I.D.	P06030-1	1	◆
	Ring, 1.575" ID Beveled 5002-156 Retaining	F04254-8 ¹	1	
	ROLLER ASSEMBLY, BLADE GUIDE ARM WITH BEARING AND SPROCKET	A09932 ¹	2	
10	Roller, Blade Guide Arm Drive	S09930	1	◆
11	Bearing, 6203-2NSL 5/8" I.D.	P06030-1	1	◆
12	Sprocket, #25 26-Tooth	S09931	1	◆
	Ring, 1.575" ID Beveled 5002-156 Retaining	F04254-8 ¹	1	

¹ Roller assemblies changed to bearing secured with retaining ring to insure proper fit. Directly interchangeable with all previous rollers supplied prior to 2/00.

SECTION 3 BLADE WHEELS & TENSIONER

3.1 Blade Drive Assembly

LT30HD D33 Rev. H8.00 - J7.00
 LT40HD D33 Rev. H8.00 - J8.00
 LT30HD G36 Rev. J1.00 - J7.00
 LT40HD G36 Rev. J1.00 - J8.00

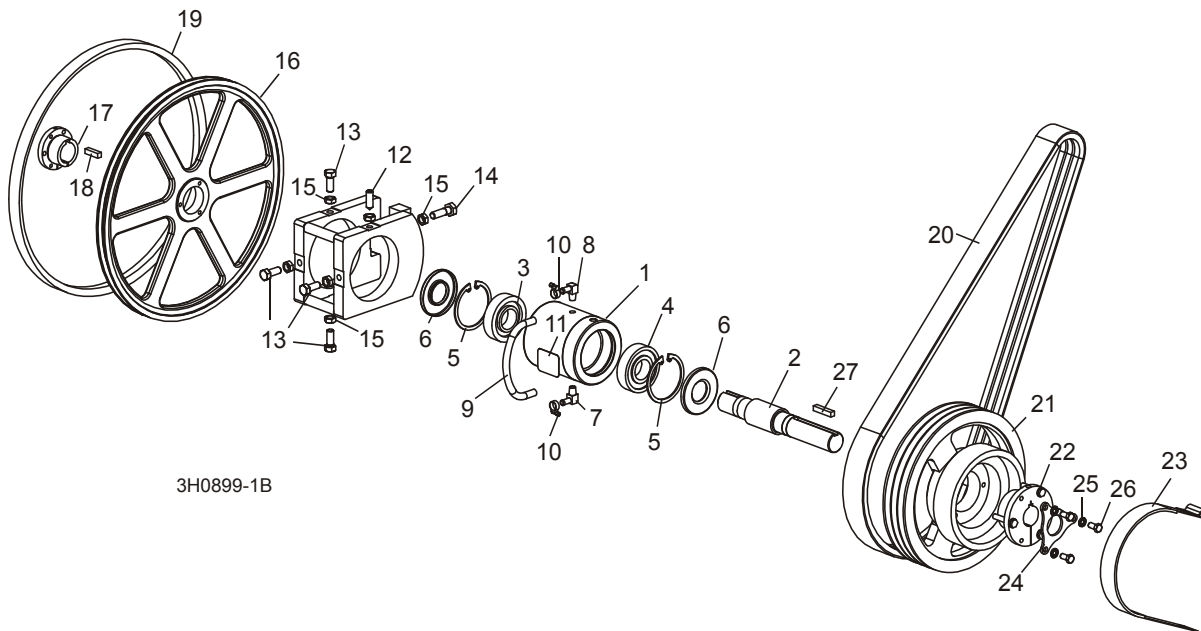

REF	DESCRIPTION (◆ Indicates Parts Available In Assemblies Only)	PART #	QTY.	
	BEARING ASSEMBLY, BLADE WHEEL DRIVE	016393	1	
	Bearing Assembly, Cylindrical Drive	016392	1	◆
1	Housing, Blade Wheel Drive Bearing	016391	1	◆
2	Shaft, Blade Wheel Drive	014005	1	◆
3	Bearing, Blade Wheel Drive #MU1308TV	P10205	1	◆
4	Bearing, Blade Wheel Drive #6308 C3 Open	016055	1	◆
5	Ring, 90mm Interior Retaining #117	F04254-17	2	
6	Seal, Drive Bearing #CR15890	P10206-K	2	
7	Fitting, 1/4" NPT x 3/8" Hose Barb Elbow	016330	1	
8	Fitting, 1/4" NPT x 3/8" Hose Barb Vented Elbow	016331	1	
9	Hose, Oil Level Viewer	016394	1	
10	Clamp, 7/32-5/8" Hose	P649	2	
11	Decal, Oil Level Gauge	017470	1	
	Instruction Sheet, Drive Bearing Replacement	016393-555	1	
12	SCREW, 1/2-20 X 1 1/2" CONE POINT SET	F05004-170	1	

Blade Wheel & Tensioner

Blade Drive Assembly

3

13	BOLT, 1/2-20 X 1 1/4" HEX HEAD GRADE 5	F05008-108	4	
14	BOLT, 1/2-20 X 1 3/4" HEX HEAD GRADE 5	F05008-49 ¹	1	
15	NUT, 1/2-20 HEX JAM	F05010-16	6	
	WHEEL KIT, DRIVE SIDE BLADE	014562	1	
16	Wheel, Drive Side Blade	016284	1	◆
17	Bushing, Modified 1 9/16" SD	016270	1	
18	Key, 3/8" x 3/8" x 1 5/8"	S12892	1	
	Instruction Sheet, Drive Side Blade Wheel Replacement	K12987-488	1	
19	BELT, BLADE WHEEL B57	P04185	1	
20	BELT, 3/5VL750 DRIVE (G36/D33)	006672 ²	1	
21	SHEAVE, 5V12.5X3 BRAKE COMBO	016531	1	
22	BUSHING, SF X 1 9/16"	016532	1	
23	STRAP, METAL-BACKED BRAKE	014391	1	
24	PLATE, BUSHING KEY RETAINER	017953 ³	1	
25	WASHER, 3/8" SPLIT LOCK	F05011-4	3	
26	BOLT, 3/8-16 X 3/4" HEX HEAD	F05007-27	3	
27	KEY, 3/8" X 3/8" X 1 7/8"	014693	1	

¹ Replaces F05008-108 1/2-20 x 1 1/4" Hex Head Grade 5 Bolt supplied prior to LT30HD/40HD Rev. J2.00. Longer bolt improves thread engagement for adjustment.

² Cog-style belt 006672 replaces 016556 originally supplied prior to 7/08 to reduce slippage. If sawmill equipped with 3 3/4" turnbuckle supplied prior to 9/03, replace with a revised 3 1/2" turnbuckle assembly A11576 to allow proper tensioning of belt ([See Section 4.2](#)).

³ Retainer Plate 017953 added LT30HD Rev. J5.01 & LT40HD Rev. J6.01.

3 Blade Wheel & Tensioner

Blade Drive Assembly

3.2 Blade Drive Assembly

LT30HD G25 **Rev. H6.00 - J7.00**
LT40HD G25 **Rev. H6.00 - J8.00**
LT30HD D33 **Rev. H6.00 - H7.00**
LT40HD D33 **Rev. H6.00 - H7.00**

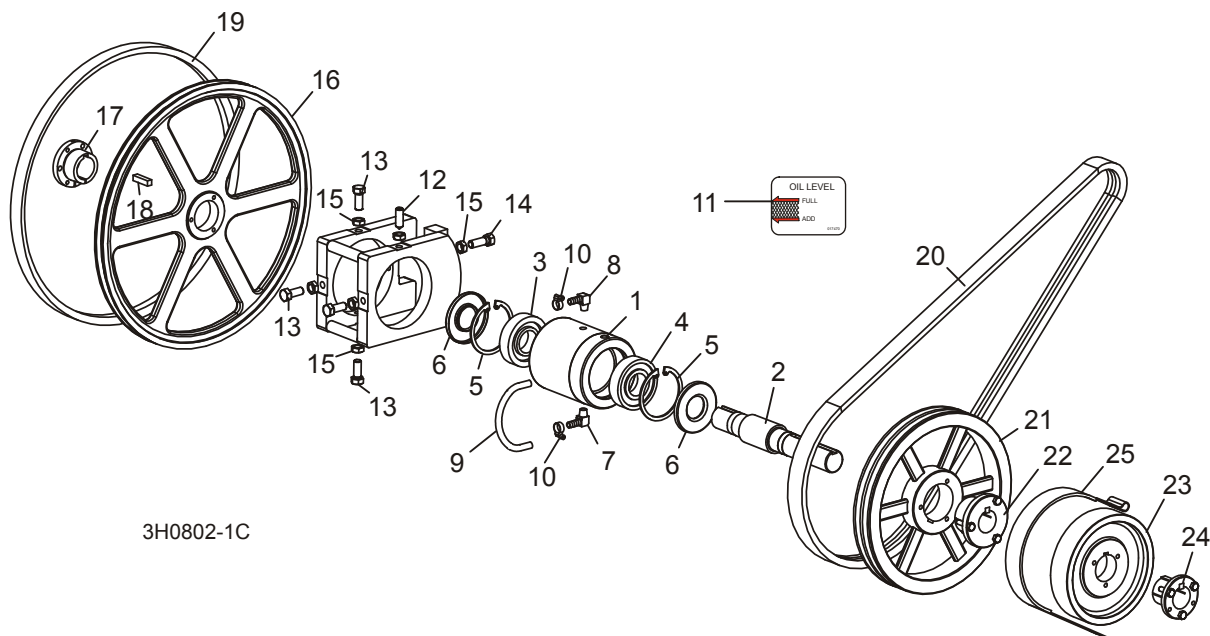

3H0802-1C

REF	DESCRIPTION (◆ Indicates Parts Available In Assemblies Only)	PART #	QTY.	
	BEARING ASSEMBLY, BLADE WHEEL DRIVE	016393	1	
	Bearing Assembly, Cylindrical Drive	016392	1	◆
1	Housing, Blade Wheel Drive Bearing	016391	1	◆
2	Shaft, Blade Wheel Drive	014005	1	◆
3	Bearing, Blade Wheel Drive #MU1308TV	P10205	1	◆
4	Bearing, Blade Wheel Drive #6308 C3 Open	016055	1	◆
5	Ring, 90mm Interior Retaining #117	F04254-17	2	
6	Seal, Drive Bearing #CR15890	P10206-K	2	
7	Fitting, 1/4" NPT x 3/8" Hose Barb Elbow	016330	1	
8	Fitting, 1/4" NPT x 3/8" Hose Barb Vented Elbow	016331	1	
9	Hose, Oil Level Viewer	016394	1	
10	Clamp, 7/32-5/8" Hose	P649	2	
11	Decal, Oil Level Gauge	017470	1	
	Instruction Sheet, Drive Bearing Replacement	016393-555	1	
12	SCREW, 1/2-20 X 1 1/2" CONE POINT SET	F05004-170	1	
13	BOLT, 1/2-20 X 1 1/4" HEX HEAD GRADE 5	F05008-108 ¹	4	
14	BOLT, 1/2-20 X 1 3/4" HEX HEAD GRADE 5	F05008-49 ²	1	

Blade Wheel & Tensioner

Blade Drive Assembly

3

15	NUT, 1/2-20 HEX JAM	F05010-16	6	
	WHEEL KIT, DRIVE SIDE BLADE	014562	1	
16	Wheel, Drive Side Blade	016284	1	◆
17	Bushing, Modified 1 9/16" SD	016270	1	
18	Key, 3/8" x 3/8" x 1 5/8"	S12892	1	
	Instruction Sheet, Drive Side Blade Wheel Replacement	K12987-488	1	
19	BELT, BLADE WHEEL B57	P04185	1	
20	BELT, 2BXF71 DRIVE (G25)	036163 ³	1	
	BELT, 3BX72 DRIVE (D33)	014085	1	
	PULLEY KIT, 2B124SK DRIVE (G25)	014692	1	
	PULLEY KIT, 3B124SK DRIVE (D33)	014691	1	
21	Pulley, 2B124SK Drive (G25)	014689	1	◆
	Pulley, 3B124SK Drive (D33)	014688	1	◆
22	Bushing, 1 9/16" Type 'SK'	014690	1	
	Key, 3/8" x 3/8" x 1 7/8"	014693	1	
23	WHEEL, BRAKE	014000	1	
24	BUSHING, 1 9/16" P1	014003	1	
25	STRAP, METAL-BACKED BRAKE	014391	1	

¹ Five 1/2-20 x 1 1/4" Hex Head Bolts replace four 1/2-20 x 1 1/4" Set Screws (F05008-109) and one 1/2-20 x 1 1/2" Hex Head Bolt (F05008-53) supplied prior to LT30HD/40HD Rev. H7.00.

² Replaces F05008-108 1/2-20 x 1 1/4" Hex Head Grade 5 Bolt supplied prior to LT30HD/40HD Rev. J2.00. Longer bolt improves thread engagement for adjustment.

³ 036163 Kevlar 2BXF71 belt replaces P12949 2BX71 belt supplied prior to 9/03. Kevlar belt reduces stretch and provides greater range of adjustment.

3 Blade Wheel & Tensioner

Blade Drive Assembly

3.3 Blade Drive Assembly

LT30HD
LT40HD

Rev. G7.00 - H5.00
Rev. G7.00 - H5.00

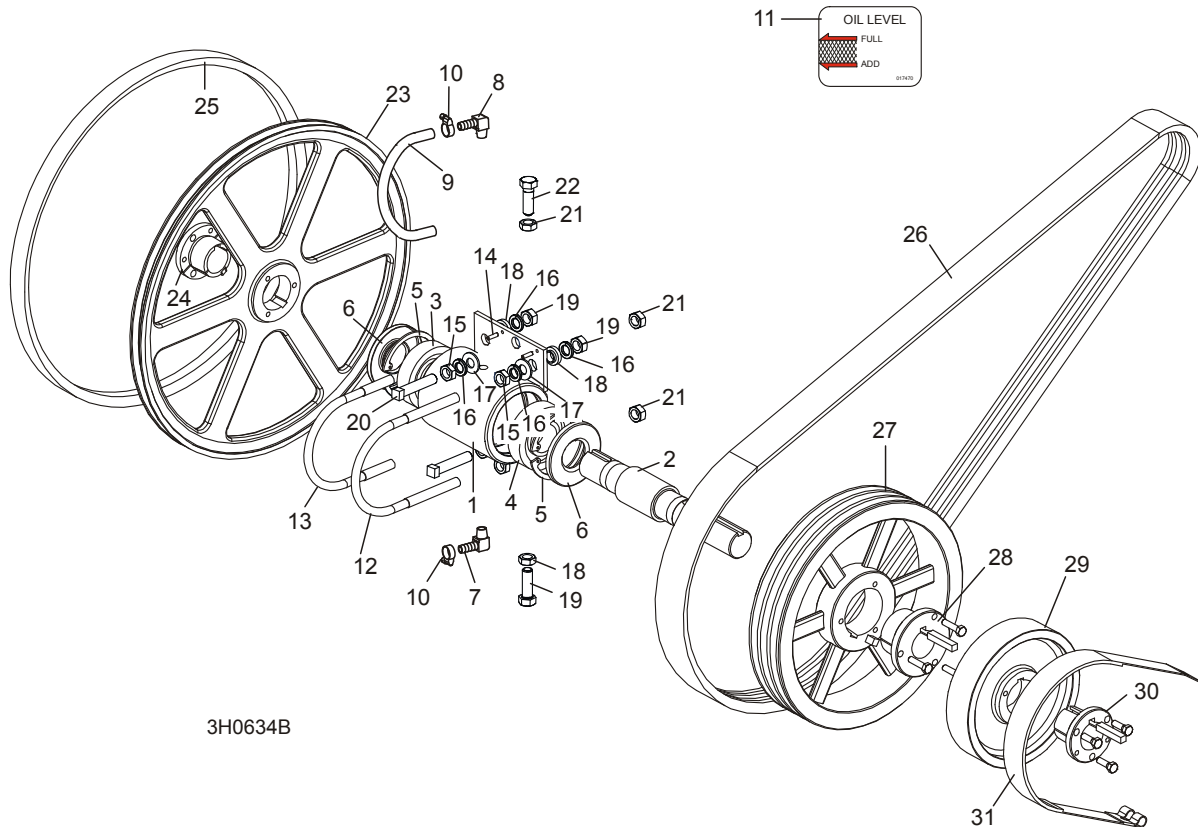

3H0634B

REF	DESCRIPTION (◆ Indicates Parts Available In Assemblies Only)	PART #	QTY.	
	BEARING ASSEMBLY, BLADE WHEEL DRIVE	014561	1	
	Bearing Assembly, Drive	014560	1	◆
1	Housing, Blade Wheel Drive Bearing	W10201	1	◆
2	Shaft, Blade Wheel Drive	014005	1	◆
3	Bearing, Blade Wheel Drive #MU1308TV	P10205	1	◆
4	Bearing, Blade Wheel Drive #6308 C3 Open	016055	1	◆
5	Ring, 90mm Interior Retaining #17	F04254-17	2	
6	Seal, Drive Bearing #CR15890	P10206-K	2	
7	Fitting, 1/4" NPT x 3/8" Hose Barb Elbow	016330 ¹	1	
8	Fitting, 1/4" NPT x 3/8" Hose Barb Vented Elbow	016331 ¹	1	
9	Hose, Oil Level Viewer	016337 ¹	1	
10	Clamp, 7/32-5/8" Hose	P649 ¹	2	
11	Decal, Oil Level Gauge	017470 ¹	1	
12	Bolt, 1/2-13 Long U	S10207-1	1	

13	Bolt, 1/2-13 Short U	S10207-2	1	
14	Pin, 3/16" X 5/8" Roll	F05012-22	2	
15	Nut, 1/2-20 Hex Jam	F05010-16	4	
16	Washer, 1/2" Split Lock	F05011-9	8	
17	Washer, 1/2" SAE Flat	F05011-2	4	
18	Spacer, .510" x .937" x .34"	S04253	4	
19	Nut, 1/2-13 Hex	F05010-35	4	
20	Screw, 1/2-20 x 2 1/2" Square Head Full Thread Set	F05008-110	2	
21	Nut, 1/2-13 Hex Nylon Lock	F05010-8	4	
22	Bolt, 1/2-20 x 1 1/2" Hex Head Grade 5	F05008-53	2	
	Instruction Sheet, Bearing Retrofit	K10200-275	1	
	WHEEL KIT, DRIVE SIDE BLADE	014562 ²	1	
23	Wheel, Drive Side Blade	016284 ²	1	◆
24	Bushing, Modified 1 9/16" SD	016270 ²	1	
	Key, 3/8" x 3/8" x 1 5/8"	S12892 ²	1	
	Instruction Sheet, Drive Side Blade Wheel Replacement	K12987-488	1	
25	BELT, BLADE WHEEL B57	P04185	1	
26	BELT, 3BX72 DRIVE (D30/D33)	014085	1	
	BELT, 2BXF71 DRIVE (G25)	036163 ³	1	
	PULLEY KIT, 3B124SK DRIVE (D30/D33)	014691 ⁴	1	
	PULLEY KIT, 2B124SK DRIVE (G25)	014692 ⁵	1	
27	Pulley, 3B124SK Drive (D30/D33)	014688	1	◆
	Pulley, 2B124SK Drive (G25)	014689	1	◆
28	Bushing, 1 9/16" Type 'SK'	014690	1	
	Key, 3/8" x 3/8" x 1 7/8"	014693	1	
29	WHEEL, BRAKE	014000	1	
30	BUSHING, 1 9/16" P1	014003	1	
31	STRAP, METAL-BACKED BRAKE	014391	1	

¹ Oil level viewer added 6/99 (rev. H3.00). New fittings replace P05498 1/4" NPT Pipe Plug and P12868 1/4" NPT Vented Pipe Plug supplied prior to 6/99 (and P11757 1/4" NPT Square Head Pipe Plug supplied prior to 12/98).

² SD type wheel and bushing replace P1 style wheel (P12891) and bushing (014098) supplied before LT30HD/40HD Rev. H2.00 to reduce wheel wobble. Use P1 bushing 014098 for original wheel.

³ 036163 Kevlar 2BXF71 belt replaces P12949 2BX71 belt supplied prior to 9/03. Kevlar belt reduces stretch and provides greater range of adjustment.

⁴ 014691 Drive Pulley Kit replaces 014001 Pulley, 014002 Bushing, and S12892 Key originally supplied before LT30HDD33/40HDD33 Rev. H4.00.

⁵ 014692 Drive Pulley Kit replaces 014416 Pulley, 014002 Bushing, and S12892 Key originally supplied before LT30HDG25/40HDG25 Rev. H5.00.

3 Blade Wheel & Tensioner

Blade Drive Assembly

3.4 Blade Drive Assembly

LT30HD
LT40HD

Rev. G1.00 - G6.06
Rev. G1.00 - G6.06

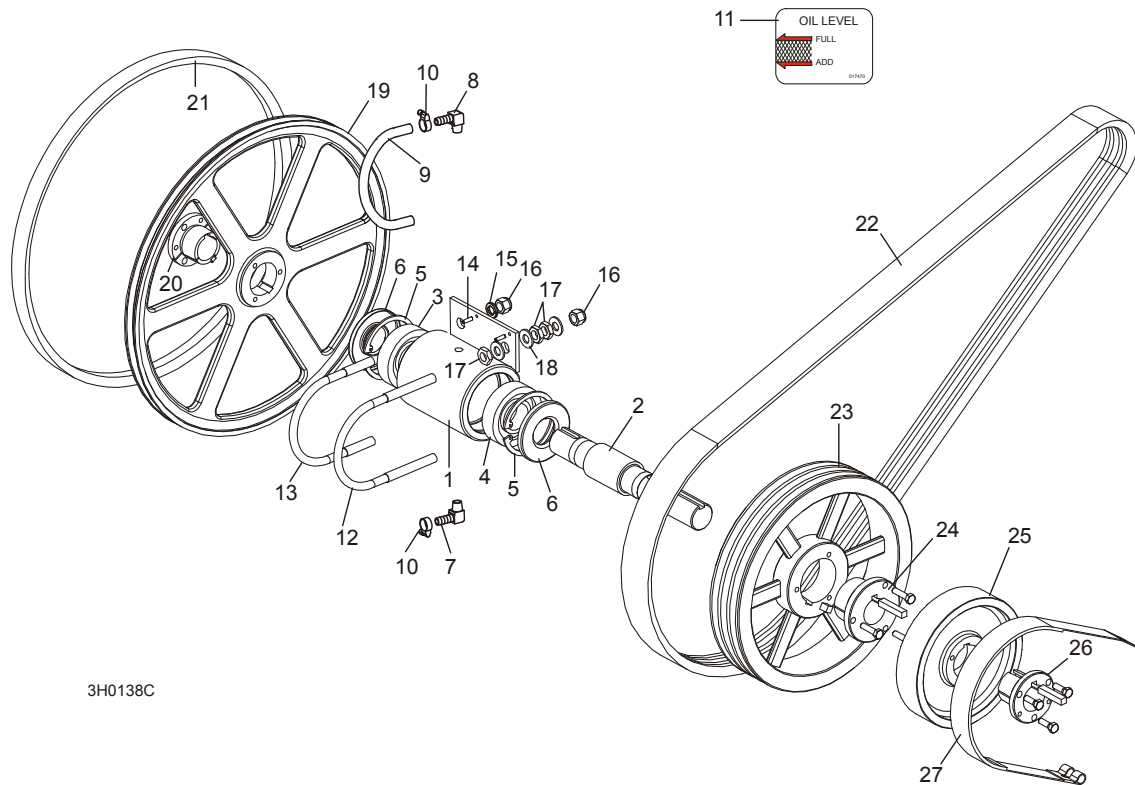

3H0138C

REF	DESCRIPTION (◆ Indicates Parts Available In Assemblies Only)	PART #	QTY.	
	BEARING ASSEMBLY, BLADE WHEEL DRIVE	014561 ¹	1	
	Bearing Assembly, Drive	014560	1	◆
1	Housing, Blade Wheel Drive Bearing	W10201	1	◆
2	Shaft, Blade Wheel Drive	014005	1	◆
3	Bearing, Blade Wheel Drive #MU1308TV	P10205	1	◆
4	Bearing, Blade Wheel Drive #6308 C3 Open	016055 ²	1	◆
5	Ring, 90mm Interior Retaining #I17	F04254-17	2	
6	Seal, Drive Bearing #CR15890	P10206-K	2	
7	Fitting, 1/4" NPT x 3/8" Hose Barb Elbow	016330 ³	1	
8	Fitting, 1/4" NPT x 3/8" Hose Barb Vented Elbow	016331 ³	1	
9	Hose, Oil Level Viewer	016337 ³	1	
10	Clamp, 7/32-5/8" Hose	P649 ³	2	
11	Decal, Oil Level Gauge	017470 ³	1	
12	Bolt, 1/2-13 Long U	S10207-1	1	

13	Bolt, 1/2-13 Short U	S10207-2	1	
14	Pin, 3/16" X 5/8" Roll	F05012-22	2	
15	Washer, 1/2" Split Lock	F05011-9	2	
16	Nut, 1/2-13 Hex Nylon Lock	F05010-8	4	
17	Nut, 1/2-13 Hex Jam	F05010-31	6	
18	Washer, 1/2" SAE Flat	F05011-2	6	
	Instruction Sheet, Bearing Retrofit	K10200-275	1	
	PLATE, DRIVE BEARING MOUNT	016116	1	
	BAR, BEARING PLATE BRACE	016113	1	
	BLOCK, BEARING PLATE BRACE	016112	1	
	SCREW, 1/2-20 X 2 1/2" SQUARE HEAD FULL THREAD SET	F05008-110	1	
	WHEEL KIT, DRIVE SIDE BLADE	014562 ⁴	1	
19	Wheel, Drive Side Blade	016284 ⁴	1	◆
20	Bushing, Modified 1 9/16" SD	016270 ⁴	1	
	Key, 3/8" x 3/8" x 1 5/8"	S12892 ⁴	1	
	Instruction Sheet, Drive Side Blade Wheel Replacement	K12987-488	1	
21	BELT, BLADE WHEEL B57	P04185	1	
22	BELT, 3BX72 DRIVE (D30)	014085	1	
	BELT, 2BX71 DRIVE (G25)	036163 ⁵		
	BELT, 2BX74 DRIVE (G24 ⁶)	P10277-2	1	
23	PULLEY, 3B5V124 SPECIAL DRIVE (D30)	014001 ⁷	1	◆
	PULLEY, 2B5V124 SPECIAL (G24 ⁶/G25)	014416 ⁸	1	◆
24	BUSHING, 1 9/16" SPLIT TAPER "B"	014002	1	
25	WHEEL, BRAKE	014000	1	
26	BUSHING, 1 9/16" SPLIT TAPER "P1"	014003	1	
27	STRAP, METAL-BACKED BRAKE	014391	1	

¹ Optional Drive Side Bearing Brace Add-On Kit (016121) available 6/98. Allows for easier and more precise adjustment of drive side bearing housing. Includes 016111 Bearing Plate Brace, needed hardware, and installation instructions.

² Replaces P10205 Blade Wheel Drive Bearing #MU1308TV 6/98.

³ Oil level viewer added 6/99. New fittings replace P05498 1/4" NPT Pipe Plug and P12868 1/4" NPT Vented Pipe Plug supplied prior to 6/99 (and P11757 1/4" NPT Square Head Pipe Plug supplied prior to 12/98).

⁴ SD type wheel and bushing replace P1 style wheel (P12891) and bushing (014098) originally supplied to reduce wheel wobble. Use P1 bushing 014098 for original wheel.

⁵ 036163 Kevlar 2BXF71 belt replaces P12949 2BX71 belt supplied prior to 9/03. Kevlar belt reduces stretch and provides greater range of adjustment.

⁶ G24 engine option available for mills prior to LT30HD/40HD Rev. G6.00 only.

⁷ Use Pulley Kit 014691 to replace 014001 Pulley, 014002 Bushing, and S12892 Key originally supplied ([See Section 3.4](#)).

⁸ Use Pulley Kit 014692 to replace 014416 Pulley, 014002 Bushing, and S12892 Key originally supplied ([See Section 3.4](#)).

3 Blade Wheels & Tensioner

Idle Blade Wheel Assembly

3.5 Idle Blade Wheel Assembly

LT30HD
LT40HD

Rev. H6.00 - J7.00
Rev. H6.00 - J8.00

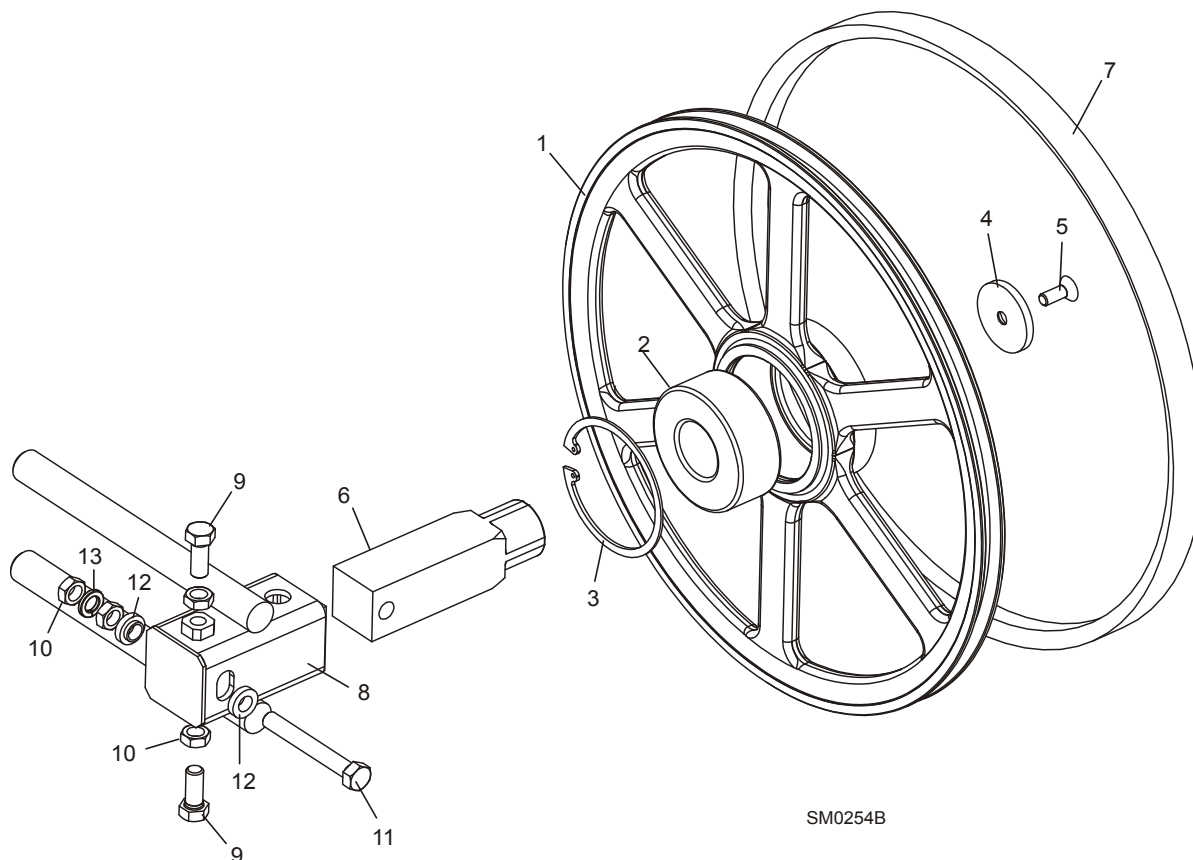

REF	DESCRIPTION (◆ Indicates Parts Available In Assemblies Only)	PART #	QTY.	
	WHEEL ASSEMBLY, IDLE SIDE BLADE	016120	1	
1	Wheel, Idle Side Blade	016013	1	◆
2	Bearing, Idle Side Blade Wheel #5309-2RS, C3, SRI-2 Grease	016014	1	
3	Ring, 100mm Internal Retaining Beveled	F04254-28	1	
	SHAFT KIT, IDLE BLADE WHEEL	016441 ¹	1	
4	Washer, 13/32" I.D. x 2 3/16 O.D. x 1/4"	016397	1	
5	Bolt, 3/8-16 x 1" Flat Head Socket	F05007-64	1	
6	Shaft, Idle Side Blade Wheel	016398	1	
7	BELT, BLADE WHEEL B57	P04185	1	
8	HOUSING, IDLE BLADE WHEEL SHAFT	016103	1	
9	SCREW, 1/2-20 X 1 1/4" HEX HEAD GRADE 5	F05008-108 ²	2	
10	NUT, 1/2-20 HEX JAM	F05010-16	4	
11	BOLT, 1/2-20 X 3 3/4" HEX HEAD FULL THREAD GRADE 2	F05008-111	1	

Blade Wheels & Tensioner
Idle Blade Wheel Assembly

3

12	SPACER, 1/2" I.D. FLANGED	S04253	2	
13	WASHER, 1/2" SPLIT LOCK	F05011-9	1	

¹ Shaft Kit 016441 includes new shaft and 3/8" hardware (replaces 016092 with 5/16" hardware previously supplied).

² Replaces 1/2-20 x 1 1/4" Flat Point Set Screw (F05008-109) supplied prior to LT30HD/40HD Rev. H7.00.

3 Blade Wheels & Tensioner

Idle Blade Wheel Assembly

3.6 Idle Blade Wheel Assembly

LT30HD
LT40HD

Rev. G7.00 - H5.00
Rev. G7.00 - H5.00

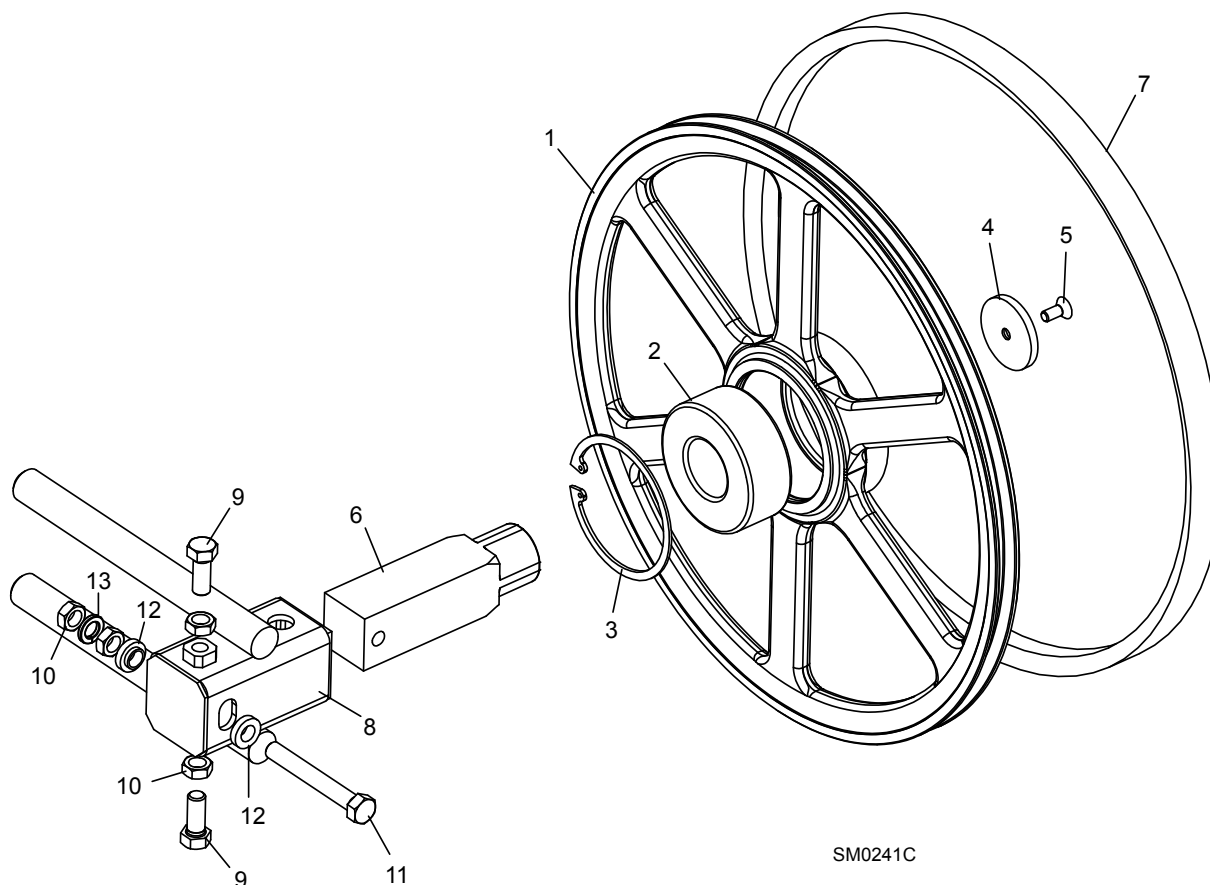

REF	DESCRIPTION (◆ Indicates Parts Available In Assemblies Only)	PART #	QTY.	
	WHEEL ASSEMBLY, IDLE SIDE BLADE	016120 ¹	1	
1	Wheel, Idle Side Blade	016013	1	◆
2	Bearing, Idle Side Blade Wheel #5309-2RS, C3, SRI-2 Grease	016014 ¹	1	
3	Ring, 100mm Internal Retaining Beveled	F04254-28 ¹	1	
4	WASHER, 2 3/16 X 1/4"	016095 ¹	1	
5	BOLT, 5/16-18 X 3/4" FLAT HEAD SOCKET	F05006-95 ¹	1	
6	SHAFT, IDLE SIDE BLADE WHEEL	016092 ²	1	◆
7	BELT, BLADE WHEEL B57	P04185	1	
8	HOUSING, IDLE BLADE WHEEL SHAFT	016103	1	
9	SCREW, 1/2-20 X 1 1/4" HEX HEAD GRADE 5	F05008-108 ³	2	
10	NUT, 1/2-20 HEX JAM	F05010-16	4	

Blade Wheels & Tensioner

Idle Blade Wheel Assembly

3

11	BOLT, 1/2-20 X 3 3/4" HEX HEAD FULL THREAD GRADE 2	F05008-111	1	
12	SPACER, 1/2" I.D. FLANGED	S04253	2	
13	WASHER, 1/2" SPLIT LOCK	F05011-9	1	

¹ Blade Wheel Assembly 016120, Idle Shaft 016092, Retaining Washer 016095, Shaft Housing Weldment 016103, and Socket Head Bolt F05006-95 new on LT30HD and LT40HD G7.00. Use Wheel Assembly Upgrade Kit 016189 with Retrofit Shaft 016180 for previous revisions ([See Section 3.7](#)).

² Use Kit 016441 to replace shaft 016092. Kit includes new shaft and 3/8" mounting hardware ([See Section 3.5](#)).

³ Replaces 1/2-20 x 1 1/4" Flat Point Set Screw (F05008-109) originally supplied.

3 Blade Wheels & Tensioner

Idle Blade Wheel Assembly

3.7 Idle Blade Wheel Assembly

LT30HD
LT40HD

Rev. G1.00 - G6.06
Rev. G1.00 - G6.06

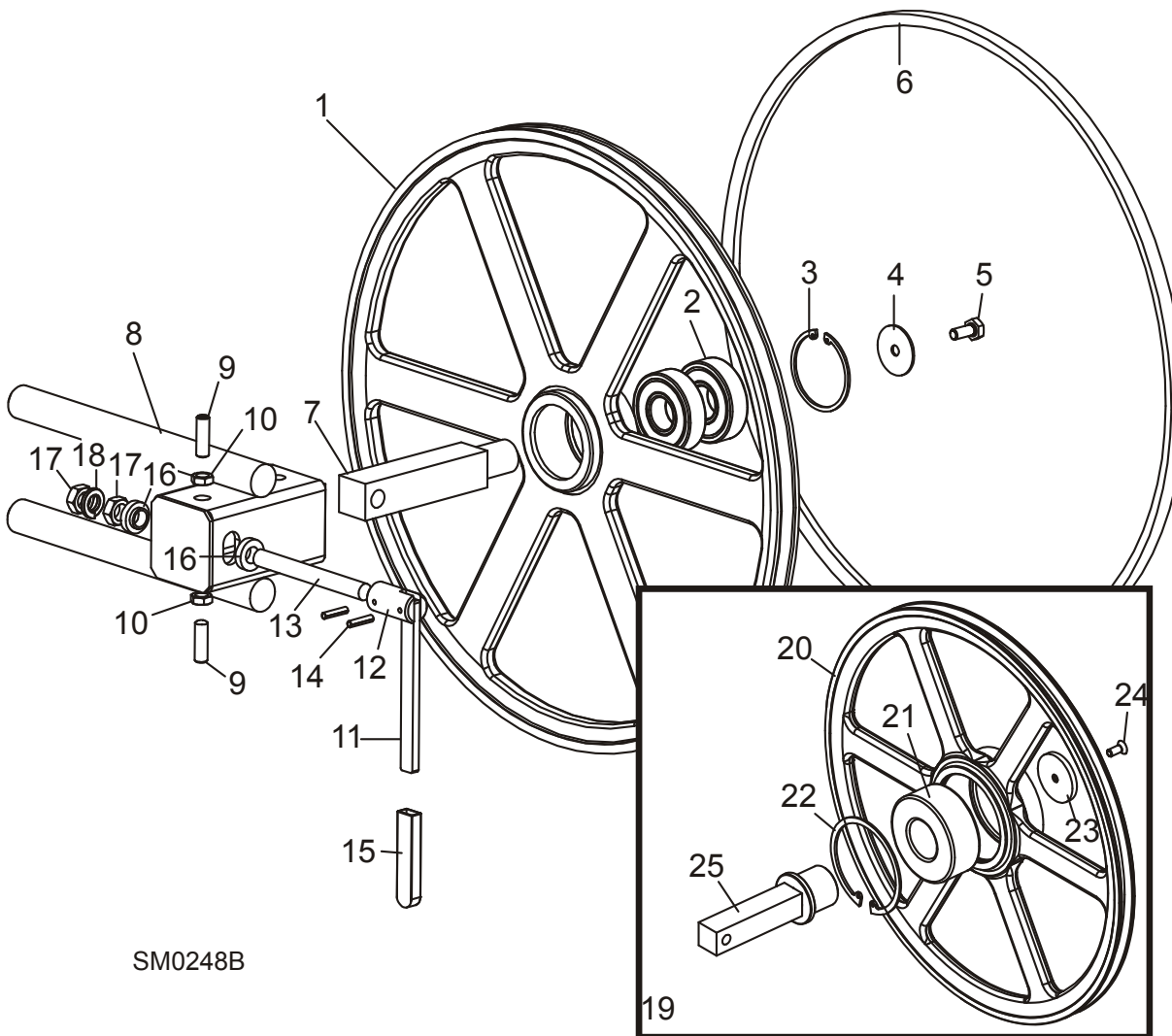

SM0248B

REF	DESCRIPTION (◆ Indicates Parts Available In Assemblies Only)	PART #	QTY.	
	WHEEL ASSEMBLY, IDLE SIDE BLADE	A08218 ¹	1	
1	Wheel, Idle Side Blade	P08125	1	◆
2	Bearing, Idle Side Blade Wheel #6305-AA, C3, ABEC-1, SRI-2 Grease	P08066 ¹	2	
3	Ring, 2 7/16" Internal Retaining	F04254-21 ¹	1	
4	WASHER, IDLE BLADE WHEEL RETAINER	S08220 ¹	1	
5	BOLT, 5/16-18 X 3/4" HEX HEAD	F05006-5 ¹	1	
6	BELT, BLADE WHEEL B57	P04185	1	

7	SHAFT, IDLE BLADE WHEEL	S12565 ¹	1	
8	HOUSING, IDLE BLADE WHEEL SHAFT	W10157	1	
9	SCREW, 3/8-16 X 1 1/4" SOCKET HEAD OVAL POINT	F05007-18	2	
10	NUT, 3/8-16 HEX JAM	F05010-29	2	
	HANDLE ASSEMBLY, IDLE SIDE PULLEY TILT	A09357	1	
11	Handle, Tilt Adjustment Screw	S08174	1	◆
12	Driver, Tilt Adjustment Screw	S09405	1	◆
13	Rod, Threaded Tilt Adjustment Screw	S09358	1	◆
14	Pin, 3/16" x 7/8" Roll	F05012-19	2	
15	SLEEVE, PLASTIC HANDLE	P08072	1	
16	SPACER, 1/2" I.D. FLANGED	S04253	2	
17	NUT, 1/2-20 HEX JAM	F05010-16	2	
18	WASHER, 1/2" SPLIT LOCK	F05011-9	1	
19	WHEEL KIT, IDLE SIDE BLADE UPGRADE	016189 ¹	1	
	Wheel Assembly, Idle Side Blade	016120	1	
20	Wheel, Idle Side Blade	016013	1	◆
21	Bearing, Idle Side Blade Wheel #5309-2RS, C3, SRI-2 Grease	016014	1	
22	Ring, 100mm Internal Retaining Beveled	F04254-28	1	
23	Washer, 2 3/16 x 1/4"	016095	1	
24	Bolt, 5/16-18 X 3/4" Flat Head Socket	F05006-95	1	
25	Shaft, Idle Side Blade Wheel Retrofit	016180	1	

¹ Upgrade kit 016189 including blade wheel with larger diameter bearing and retrofit shaft 016180 available. [See Item #19](#) for upgrade parts.

3 Blade Wheels & Tensioner

Hydraulic Blade Tensioner Assembly

3.8 Hydraulic Blade Tensioner Assembly

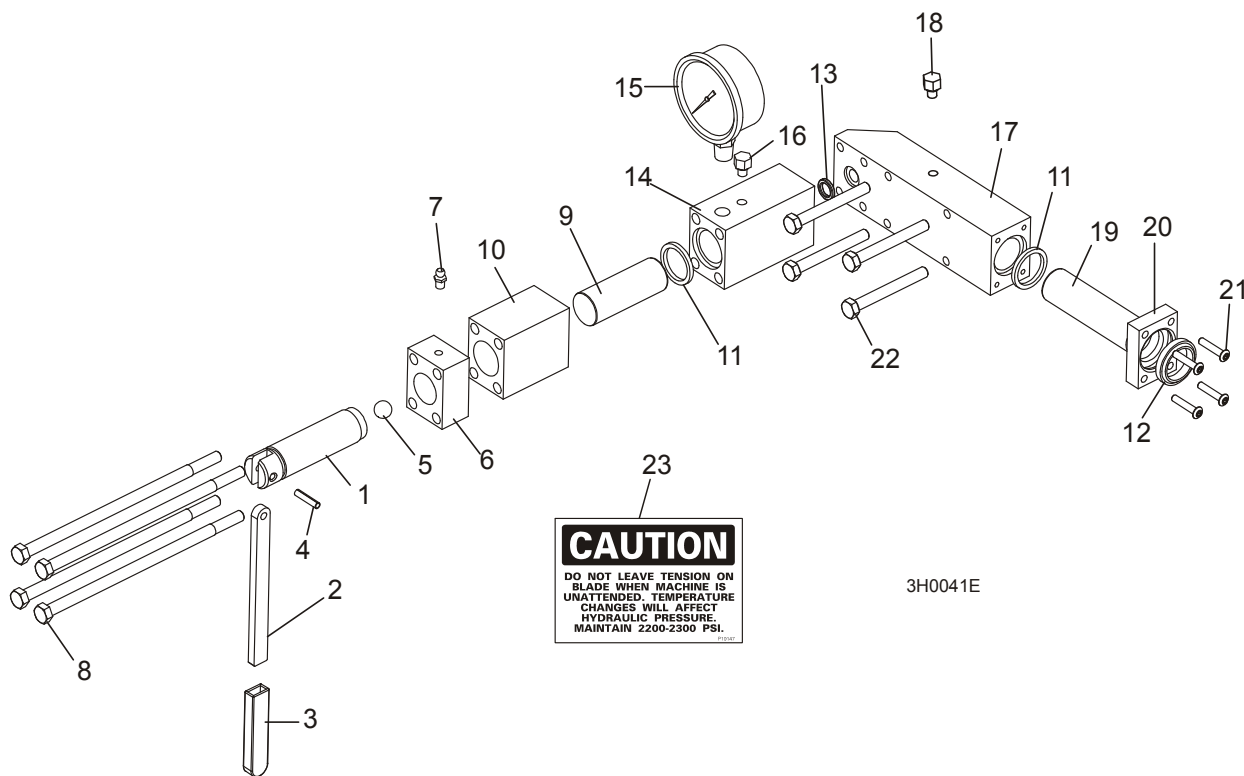

REF	DESCRIPTION (◆ Indicates Parts Available In Assemblies Only)	PART #	QTY.
	HYDRAULIC BLADE TENSIONER ASSEMBLY	A10136	1
	Handle Assembly, Hydraulic Blade Tensioner Screw	A12294	1
1	Screw, Hydraulic Blade Tensioner	S10056	1 ◆
2	Handle, Hydraulic Tensioner Screw	S08174	1
3	Sleeve, Plastic Handle	P08072	1
4	Pin, 3/16" x 7/8" Roll	F05012-19	1
5	Ball, 1/2" Steel	P02720	1
6	Block, Threaded Tensioner End	S10062	1 ◆
7	Fitting, 1/4-28 Grease	P05060	1
	Instruction Sheet, Tensioner Screw	A12294-518	1
8	Bolt, 5/16-18 X 7 1/2" Hex Head Grade 5	F05006-43	4
9	Piston, Hydraulic Tensioner Front 2 3/4" Long	S10060	1
10	Block, Piston Guide	S10061	1
	Seal Kit, Hydraulic Tensioner	003224	1
5	Ball, 1/2" Steel	P02720	1
11	Seal, 1" Diameter	P10051	2
12	Wiper, 1" Diameter	P10053	1
13	Ring, 5/8" X 3/32" Square "O"	P10377	1

Blade Wheels & Tensioner

Hydraulic Blade Tensioner Assembly

3

14	Block, Hydraulic Tensioner Gauge Mounting	S10140	1	
15	Gauge, 5000 P.S.I.	P10052	1	
16	Plug, Hydraulic Tensioner Fill	P10065	1	
	Block Assembly, Rear Tensioner Piston	016329	1	
17	Block, Rear Tensioner Piston	S10142 ¹	1	◆
18	Plug, Hydraulic Tensioner Fill	P10065	1	
19	Piston, Hydraulic Tensioner Rear 3 5/8" Long	S10059	1	
20	Block, Rear Piston End	S10089	1	
21	Bolt, #10-24 X 1" Socket Button Head	F05004-43	4	
22	Bolt, 5/16-18 X 2 3/4" Hex Head Grade 5	F05006-28	4	
23	Decal, Hydraulic Tension Caution	P10147	1	
	Instruction Sheet, Hydraulic Tensioner Installation	A10136-272	1	

¹ Plug added to S10142 Rear Tensioner Piston Block 6/99 (LT30HD/40HD rev. H3.00).

4 Saw Head
Middle Throat Screw

SECTION 4 SAW HEAD

4.1 Middle Throat Screw

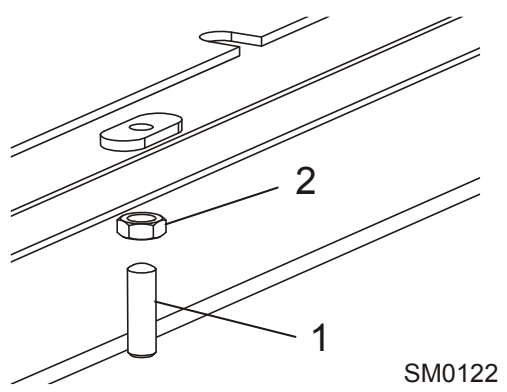

REF	DESCRIPTION (◆ Indicates Parts Available In Assemblies Only)	PART #	QTY.	
1	SCREW, 3/8-16 X 1 1/4" OVAL POINT SOCKET SET	F05007-18	1	
2	NUT, 3/8-16 HEX JAM	F05010-29	1	

4.2 Clutch/Brake Lever Assembly (D33/G36)

LT30HD
LT40HD

Rev. H8.00 - J7.00
Rev. H8.00 - J8.00

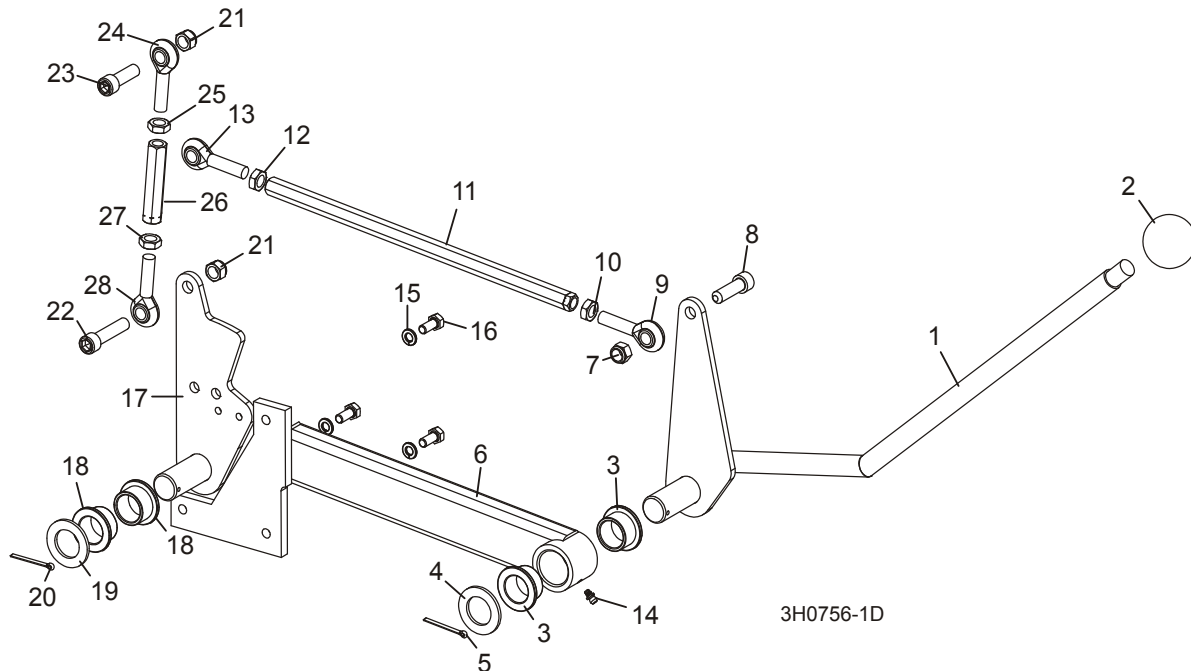

REF	DESCRIPTION (◆ Indicates Parts Available In Assemblies Only)	PART #	QTY.	
	HANDLE ASSEMBLY, EXTENDED CLUTCH/BRAKE	016317	1	
1	Lever, Clutch/Brake	016295	1	◆
2	Knob, Plastic Round	P04211	1	
3	Bushing, Clutch/Brake Pivot	P737	2	
4	Washer, Clutch/Brake Pivot	P116	1	
5	Pin, 1/8" X 1 1/2" Cotter	F05012-49	1	
6	Extension Weldment, Clutch Handle	015241	1	
7	Nut, 7/16-20 Nylon Lock	F05010-83	1	
8	Screw, 7/16-20 x 1 1/2" Socket Head	F05007-55	1	
9	Rod End, 7/16-20 Left Hand Thread	P11578	1	
10	Nut, 7/16-20 Hex Jam Left Hand Thread	F05010-87	1	
11	Rod, Clutch Extension	015073	1	
12	Nut, 7/16-20 Hex Jam	F05010-38	1	
13	Rod End, 7/16-20 Right Hand Thread	P11579	1	
14	Fitting, 3/16" Straight Grease	P04107	1	
15	WASHER, 5/16" SPLIT LOCK	F05011-13	3	
16	BOLT, 5/16-18 X 3/4" HEX HEAD	F05006-5	3	
17	PLATE WELDMENT, CLUTCH PIVOT	016296	1	
18	BUSHING, CLUTCH/BRAKE PIVOT	P737	2	

4

Saw Head

Clutch/Brake Lever Assembly (D33/G36)

19	WASHER, CLUTCH/BRAKE PIVOT	P116	1	
20	PIN, 1/8" X 1 1/2" COTTER	F05012-49	1	
21	NUT, 7/16-20 HEX NYLON LOCK	F05010-83	2	
22	BOLT, 7/16-20 X 2" SOCKET HEAD	F05007-120	1	
23	BOLT, 7/16-20 X 1 1/2" SOCKET HEAD	F05007-55	1	
	TURNBUCKLE ASSEMBLY, 3 1/2" CLUTCH/BRAKE LEVER	A11576 ¹	1	
24	Rod End, 7/16-20 Right Hand Thread	P11579	1	
25	Nut, 7/16-20 Hex Jam	F05010-38	1	
26	Turnbuckle, 3 1/2" Clutch/Brake Lever	S12262 ¹	1	◆
27	Nut, 7/16-20 Hex Jam Left Hand Thread	F05010-87	1	
28	Rod End, 7/16-20 Left Hand Thread	P11578	1	

¹ Turnbuckle revised from 3 3/4" to 3 1/2" to provide increased adjustment (9/03).

4.3 Clutch/Brake Lever Assembly (D33)

LT30HD
LT40HD

Rev. H3.00 - H7.00
Rev. H3.00 - H7.00

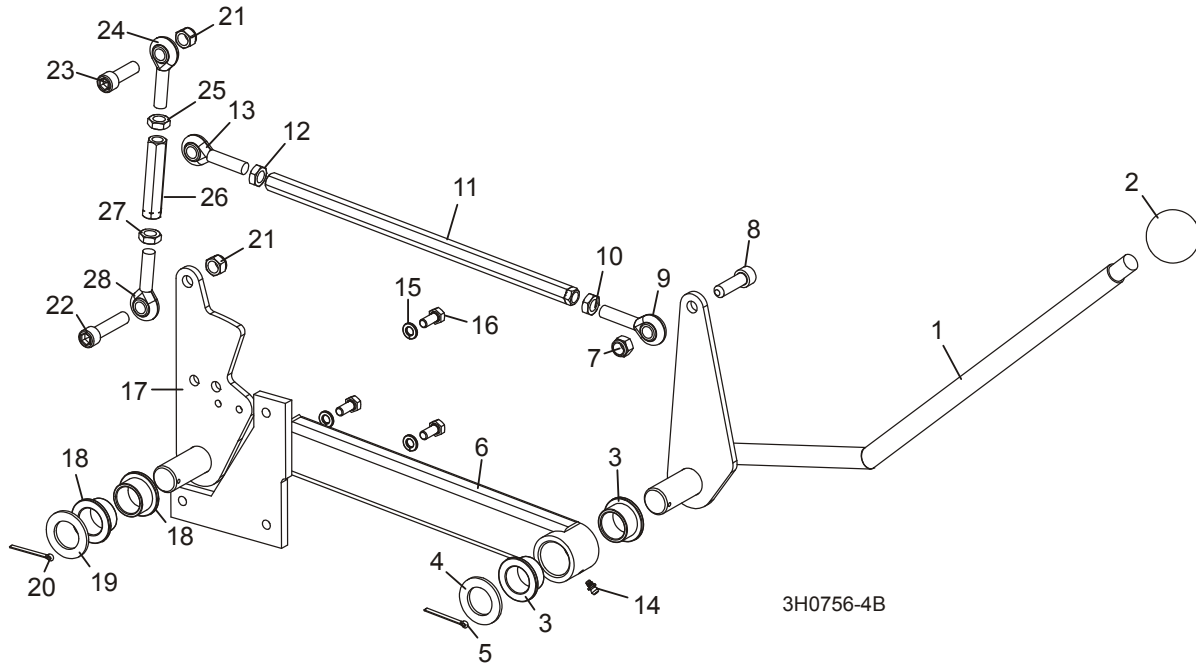

REF	DESCRIPTION (◆ Indicates Parts Available In Assemblies Only)	PART #	QTY.	
	HANDLE ASSEMBLY, EXTENDED CLUTCH/BRAKE	016317	1	
1	Lever, Clutch/Brake	016295	1	◆
2	Knob, Plastic Round	P04211	1	
3	Bushing, Clutch/Brake Pivot	P737	2	
4	Washer, Clutch/Brake Pivot	P116	1	
5	Pin, 1/8" X 1 1/2" Cotter	F05012-49 ¹	1	
6	Extension Weldment, Clutch Handle	015241	1	
7	Nut, 7/16-20 Nylon Lock	F05010-83	1	
8	Screw, 7/16-20 x 1 1/2" Socket Head	F05007-55	1	
9	Rod End, 7/16-20 Left Hand Thread	P11578	1	
10	Nut, 7/16-20 Hex Jam Left Hand Thread	F05010-87	1	
11	Rod, Clutch Extension	015073	1	
12	Nut, 7/16-20 Hex Jam	F05010-38	1	
13	Rod End, 7/16-20 Right Hand Thread	P11579	1	
14	Fitting, 3/16" Straight Grease	P04107	1	
15	WASHER, 5/16" SPLIT LOCK	F05011-13	3	
16	BOLT, 5/16-18 X 3/4" HEX HEAD	F05006-5	3	
17	PLATE WELDMENT, CLUTCH PIVOT	016296	1	

4

Saw Head*Clutch/Brake Lever Assembly (D33)*

18	BUSHING, CLUTCH/BRAKE PIVOT	P737	2	
19	WASHER, CLUTCH/BRAKE PIVOT	P116	1	
20	PIN, 1/8" X 1 1/2" COTTER	F05012-49 ¹	1	
21	NUT, 7/16-20 HEX NYLON LOCK	F05010-83	2	
22	BOLT, 7/16-20 X 2" SOCKET HEAD	F05007-120	1	
23	BOLT, 7/16-20 X 1 1/2" SOCKET HEAD	F05007-55	1	
	TURNBUCKLE ASSEMBLY, 3" CLUTCH/BRAKE LEVER	A12304	1	
24	Rod End, 7/16-20 Right Hand Thread	P11579	1	
25	Nut, 7/16-20 Hex Jam	F05010-38	1	
26	Turnbuckle, 3" Clutch/Brake Lever	S11577	1	◆
27	Nut, 7/16-20 Hex Jam Left Hand Thread	F05010-87	1	
28	Rod End, 7/16-20 Left Hand Thread	P11578	1	

¹ Replaces F05012-43 1/8" x 1 3/4" Cotter Pin used prior to Rev. H6.00 to accommodate common parts.

4.4 Clutch/Brake Lever Assembly (G25)

LT30HD
LT40HD

Rev. H3.00 - J7.00
Rev. H3.00 - J8.00

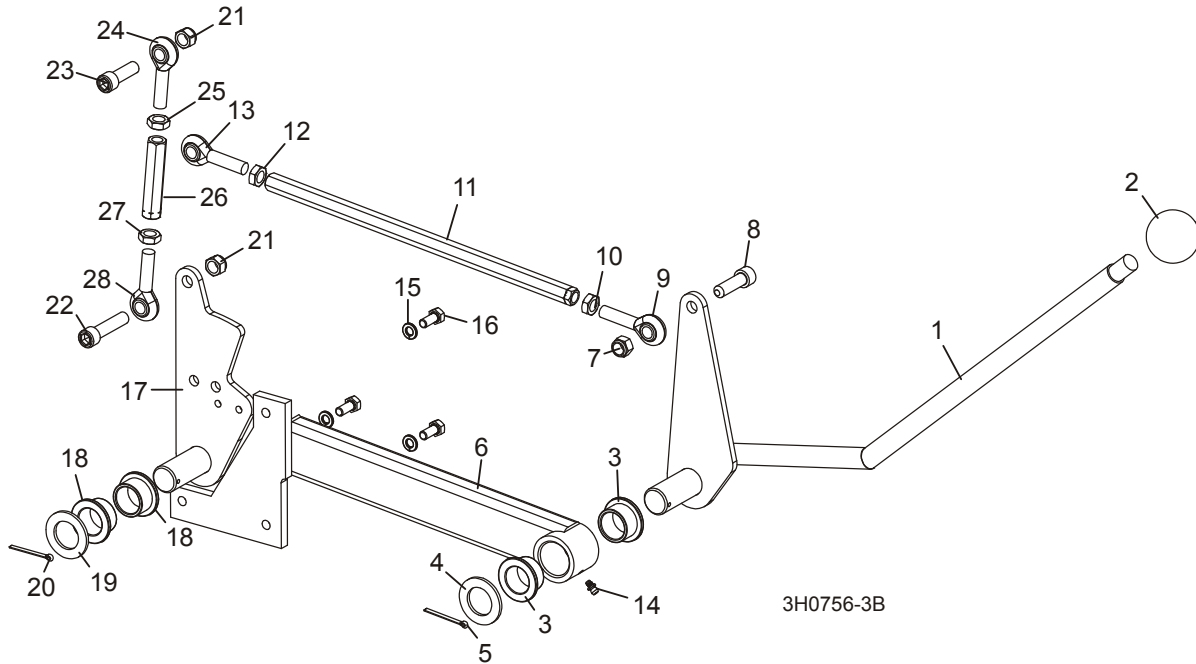

3H0756-3B

REF	DESCRIPTION (◆ Indicates Parts Available In Assemblies Only)	PART #	QTY.	
	HANDLE ASSEMBLY, EXTENDED CLUTCH/BRAKE	016317	1	
1	Lever, Clutch/Brake	016295	1	◆
2	Knob, Plastic Round	P04211	1	
3	Bushing, Clutch/Brake Pivot	P737	2	
4	Washer, Clutch/Brake Pivot	P116	1	
5	Pin, 1/8" X 1 1/2" Cotter	F05012-49 ¹	1	
6	Extension Weldment, Clutch Handle	015241	1	
7	Nut, 7/16-20 Nylon Lock	F05010-83	1	
8	Screw, 7/16-20 x 1 1/2" Socket Head	F05007-55	1	
9	Rod End, 7/16-20 Left Hand Thread	P11578	1	
10	Nut, 7/16-20 Hex Jam Left Hand Thread	F05010-87	1	
11	Rod, Clutch Extension	015073	1	
12	Nut, 7/16-20 Hex Jam	F05010-38	1	
13	Rod End, 7/16-20 Right Hand Thread	P11579	1	
14	Fitting, 3/16" Straight Grease	P04107	1	
15	WASHER, 5/16" SPLIT LOCK	F05011-13	3	
16	BOLT, 5/16-18 X 3/4" HEX HEAD	F05006-5	3	
17	PLATE WELDMENT, CLUTCH PIVOT	016296	1	

4

Saw Head*Clutch/Brake Lever Assembly (G25)*

18	BUSHING, CLUTCH/BRAKE PIVOT	P737	2	
19	WASHER, CLUTCH/BRAKE PIVOT	P116	1	
20	PIN, 1/8" X 1 1/2" COTTER	F05012-49 ¹	1	
21	NUT, 7/16-20 HEX NYLON LOCK	F05010-83	2	
22	BOLT, 7/16-20 X 2" SOCKET HEAD	F05007-120	1	
23	BOLT, 7/16-20 X 1 1/2" SOCKET HEAD	F05007-55	1	
	TURNBUCKLE ASSEMBLY, 3" CLUTCH/BRAKE LEVER	A12304	1	
24	Rod End, 7/16-20 Right Hand Thread	P11579	1	
25	Nut, 7/16-20 Hex Jam	F05010-38	1	
26	Turnbuckle, 3" Clutch/Brake Lever	S11577	1	◆
27	Nut, 7/16-20 Hex Jam Left Hand Thread	F05010-87	1	
28	Rod End, 7/16-20 Left Hand Thread	P11578	1	

¹ Replaces F05012-43 1/8" x 1 3/4" Cotter Pin used prior to Rev. H6.00 to accommodate common parts.

4.5 Clutch/Brake Lever Assembly

LT30HD
LT40HD

Rev. G1.00 - H2.00
Rev. G1.00 - H2.00

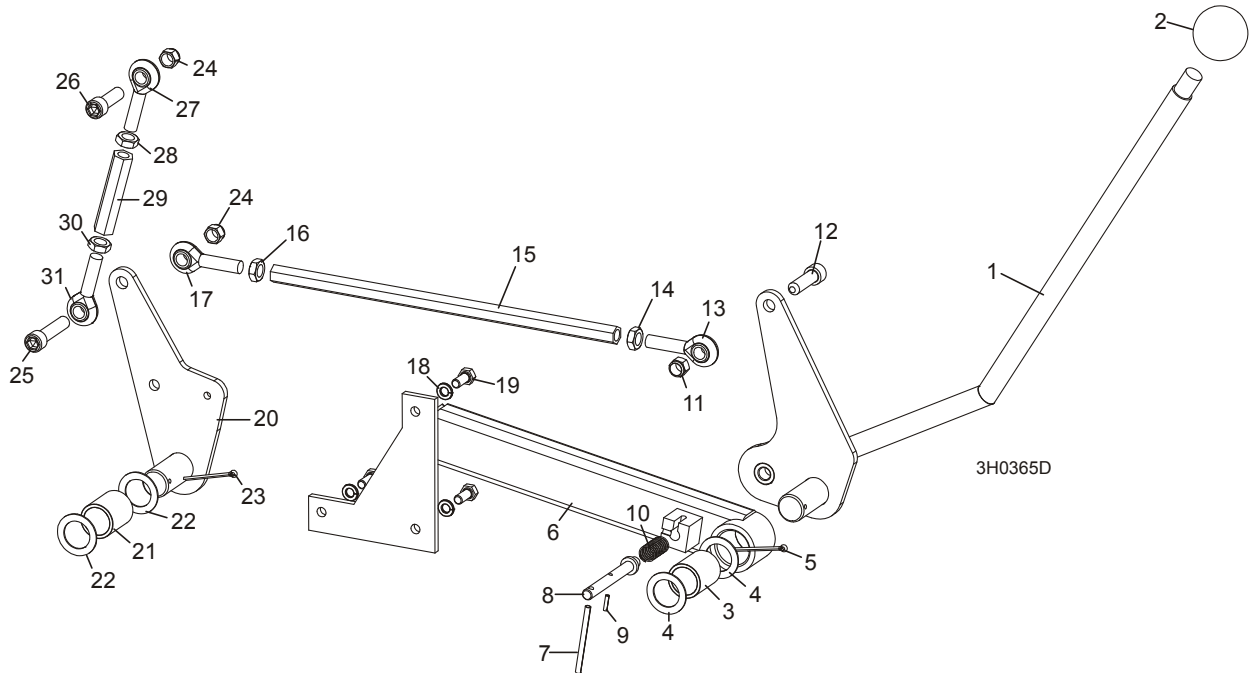

REF	DESCRIPTION (◆ Indicates Parts Available In Assemblies Only)	PART #	QTY.	
	HANDLE ASSEMBLY, EXTENDED CLUTCH/BRAKE	015273	1	
1	Lever, Clutch/Brake	015245	1	◆
2	Knob, Plastic Round	P04211	1	
3	Bushing, Clutch/Brake Pivot	P05041	1	
4	Washer, Clutch/Brake Pivot	S11570	2	
5	Pin, 1/8" X 1 1/2" Cotter	F05012-49 ¹	1	
6	Extension Weldment, Clutch Handle	015241	1	
7	Pin, 3/16 x 2 1/2" Roll	F05012-27	1	
8	Pin, Clutch Detent	015275 ²	1	◆
9	Pin, 1/8" x 9/16" Roll	F05012-30	1	
10	Spring, .58" OD x 1 1/8"	021243	1	
11	Nut, 7/16-20 Nylon Lock	F05010-83	1	
12	Screw, 7/16-20 x 1 1/2" Socket Head	F05007-55	1	
13	Rod End, 7/16-20 Left Hand Thread	P11578	1	
14	Nut, 7/16-20 Hex Jam Left Hand Thread	F05010-87	1	
15	Rod, Clutch Extension	015073	1	
16	Nut, 7/16-20 Hex Jam	F05010-38	1	
17	Rod End, 7/16-20 Right Hand Thread	P11579	1	

4

Saw Head*Clutch/Brake Lever Assembly*

18	WASHER, 5/16" SPLIT LOCK	F05011-13	3	
19	BOLT, 5/16-18 X 3/4" HEX HEAD	F05006-5	3	
20	PLATE WELDMENT, CLUTCH PIVOT	015240	1	
21	BUSHING, CLUTCH/BRAKE PIVOT	P05041	1	
22	WASHER, CLUTCH/BRAKE PIVOT	S11570	2	
23	PIN, 1/8" X 1 1/2" COTTER	F05012-49 ¹	1	
24	NUT, 7/16-20 HEX NYLON LOCK	F05010-83	2	
25	SCREW, 7/16-20 X 2" SOCKET HEAD	F05007-120	1	
26	SCREW, 7/16-20 X 1 1/2" SOCKET HEAD	F05007-55	1	
	TURNBUCKLE ASSEMBLY, 3" CLUTCH/BRAKE LEVER	A12304	1	
27	Rod End, 7/16-20 Right Hand Thread	P11579	1	
28	Nut, 7/16-20 Hex Jam	F05010-38	1	
29	Turnbuckle, 3" Clutch/Brake Lever	S11577	1	◆
30	Nut, 7/16-20 Hex Jam Left Hand Thread	F05010-87	1	
31	Rod End, 7/16-20 Left Hand Thread	P11578	1	

¹ Replaces F05012-43 1/8" x 1 3/4" Cotter Pin originally supplied to accommodate common parts.

² Detent pin removed LT30HD and LT40HD Rev. G2.05. Detent pin should be removed from previous revision mills to prevent possible injury caused by unintended use of the detent pin (such as using the pin to enable the blade to be spun by hand during blade tracking). See bulletin #970053LR for pin removal instructions.

4.6 Clutch Mount Assembly

LT30HD
LT40HD

Rev. H3.00 - J7.00
Rev. H3.00 - J8.00

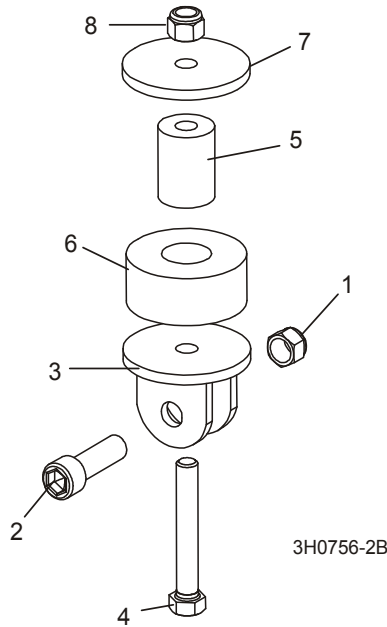

REF	DESCRIPTION (◆ Indicates Parts Available In Assemblies Only)	PART #	QTY.
1	NUT, 7/16-20 HEX NYLON LOCK	F05010-83	1
2	BOLT, 7/16-20 X 1 1/2" SOCKET HEAD	F05007-55	1
3	BRACKET, CLUTCH MOUNT	W12411	1
4	BOLT, 3/8-16 X 2 1/2" HEX HEAD	F05007-157	1
5	SPACER, MOTOR MOUNT VIBRATION BUSHING	016316	1
6	BUSHING, MOTOR MOUNT VIBRATION	P05032	1
7	WASHER, .40" I.D. X 1.44" O.D. X .18" THICK	021276 ¹	1
8	NUT, 3/8-16 NYLON LOCK	F05010-10	1

¹ Replaces S12412 3/8"x2 1/4"x3/16" Washer supplied prior to Rev. H6.00. Smaller washer eliminates interference with motor mount.

4 Saw Head

Clutch Mount Assembly

4.7 Clutch Mount Assembly

LT30HD
LT40HD

Rev. G1.00 - H2.00
Rev. G1.00 - H2.00

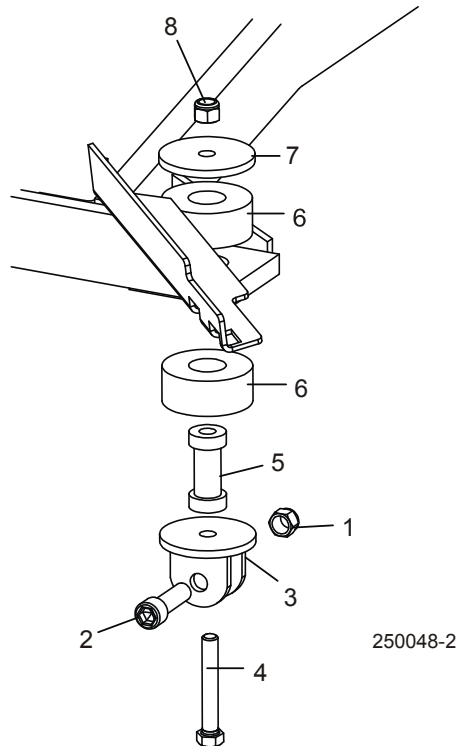

REF	DESCRIPTION (◆ Indicates Parts Available In Assemblies Only)	PART #	QTY.
1	NUT, 7/16-20 HEX NYLON LOCK	F05010-83	1
2	BOLT, 7/16-20 X 1 1/2" SOCKET HEAD	F05007-55	1
3	BRACKET, CLUTCH MOUNT	W12411	1
4	BOLT, 3/8-16 X 2 3/4" HEX HEAD	F05007-29	1
5	SPACER, MOTOR MOUNT VIBRATION BUSHING	S12410 ¹	1
6	BUSHING, MOTOR MOUNT VIBRATION	P05032 ¹	2
7	WASHER, .40" I.D. X 1.44" O.D. X .18" THICK	021276 ²	1
8	NUT, 3/8-16 NYLON LOCK	F05010-10	1

¹ Motor Mount Bushing parts may be upgraded to single-bushing style to reduce vibration ([See Section 4.6](#)). Use Motor Mount Kit 016319 (G25) or 016321 (D30) to upgrade motor mount and bushing parts.

² Replaces S12412 3/8"x2 14"x3/16" Washer originally supplied. Smaller washer eliminates interference with motor mount.

4.8 Brake Assembly

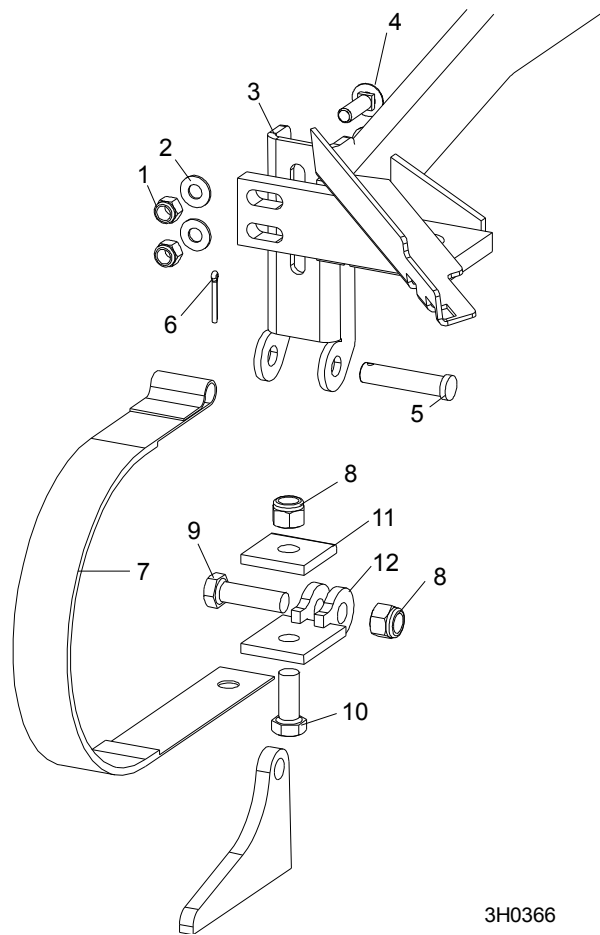

3H0366

REF	DESCRIPTION (◆ Indicates Parts Available In Assemblies Only)	PART #	QTY.
	STRAP RETROFIT, SUPER BRAKE	014441	1
1	Nut, 3/8-16 Nylon Lock	F05010-10	2
2	Washer, 3/8" SAE Flat	F05011-3	2
3	Bracket, Upper Super Brake Strap Mount	014395	1
4	Bolt, 3/8-16 x 1 1/4" Carriage Head Grade 5	F05007-127	2
5	Pin, 1/2" x 2 1/4" Clevis	F05012-81 ¹	1
6	Pin, 1/8" x 1" Cotter	F05012-1	1
7	Strap, Upper Pivot Metal Brake	014391	1
8	Nut, 1/2-13 Nylon Lock	F05010-8	2
9	Bolt, 1/2-13 x 1 3/4" Hex Head Grade 5	F05008-88	1
10	Bolt, 1/2-13 x 1 1/4" Hex Head Grade 5	F05008-37	1
11	Plate, Brake Strap Clamp	S04195	1
12	Bracket, Lower Super Brake Strap Mount	014392	1

¹ Replaces 014396 originally supplied (duplicate parts).

4 Saw Head

Water Lube Assembly

4.9 Water Lube Assembly

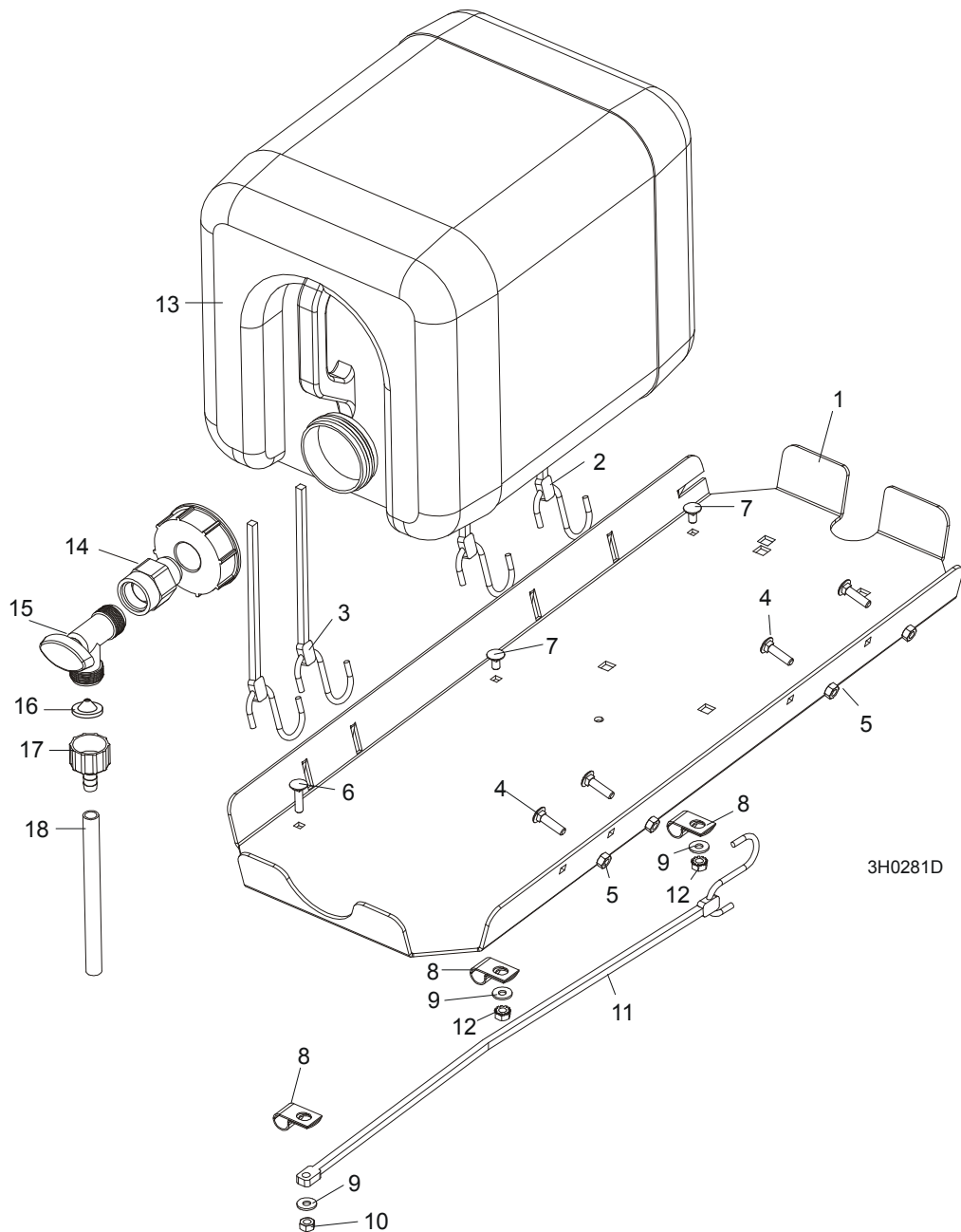

REF	DESCRIPTION (◆ Indicates Parts Available In Assemblies Only)	PART #	QTY.	
	TRAY ASSEMBLY, FUEL TANK/WATER BOTTLE	A11685	1	
1	Tray, Fuel Tank/Water Bottle	S11684	1	◆
2	Strap, 24" Rubber (For Fuel Tank - See Engine Manual)	P11258	2	
3	Strap, 20" Rubber	P11668	2	

4	Bolt, 1/4-20 X 1" Carriage Head	F05005-34	4	
5	Nut, 1/4-20 Hex Lock	F05010-21	4	
6	BOLT, 1/4-20 X 1" CARRIAGE HEAD	F05005-34	1	
7	BOLT, 1/4-20 X 1/2" CARRIAGE HEAD	F05005-33	2	
8	CLAMP, 1/2" EMT HOSE	P07584	3	
9	WASHER, 1/4" SAE FLAT	F05011-11	3	
10	NUT, 1/4-20 HEX LOCK	F05010-21	1	
11	STRAP, 15" RUBBER	P07461	1	
12	NUT, 1/4-20 SELF-LOCKING	F05010-9	2	
13	BOTTLE ASSY, WATER LUBE W/CAP	014642 ¹	1	
14	FITTING, 3/4FPT X 3/4MPT	014636	1	
15	FITTING, WATER LUBE SHUTOFF VALVE	014100	1	
16	FILTER, WATER LUBE	016086 ²	1	
17	FITTING, 5/8" NPT TO 3/8" HOSE BARB	014113	1	
18	TUBING, WATER LUBE 3/8" I.D.	R01885	7 ft.	

¹ Use Water Bottle Assembly w/Cap 014642 to service all bottle/cap combinations previously supplied. Bottle 014367, 61mm Cap 014773 and 70mm Cap 036744 no longer available separately. Replaces 015499 bottle kit. Fittings removed from kit 6/98. Order fittings separately.

² Filter recommended for Super models to prevent debris from entering water lube solenoid valve.

4 Saw Head Saw Head Decals

4.10 Saw Head Decals

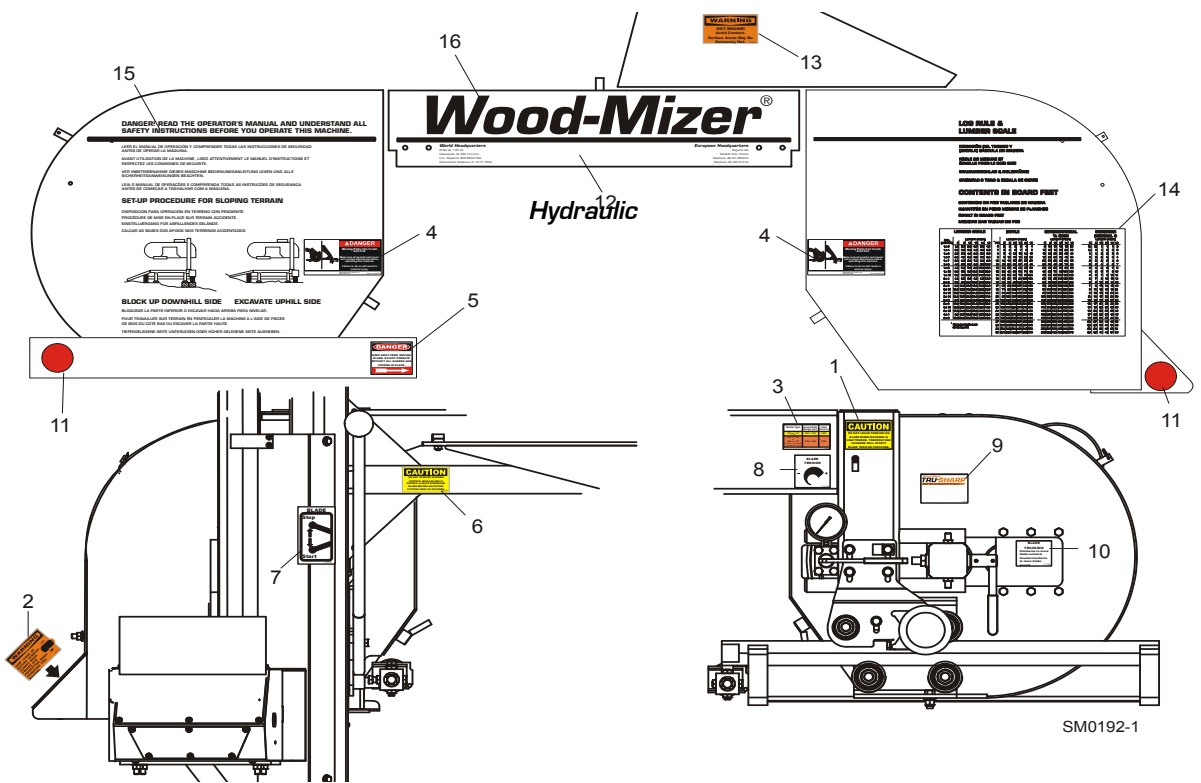

REF	DESCRIPTION (◆ Indicates Parts Available In Assemblies Only)	PART #	QTY.
1	DECAL, BLADE TENSION CAUTION	P10147	1
2	DECAL, SAWDUST CHUTE WARNING	P11754	1
3	DECAL, BLADE TENSION RANGES	P12373	1
4	DECAL, BLADE COVERS DANGER	033254 ¹	2
5	DECAL, BLADE DANGER ARROW RIGHT	S11752	1
6	DECAL, UP/DOWN CAUTION	S11762	1
7	DECAL, BLADE START/STOP	P11779	1
8	DECAL, BLADE TENSION INFO	P11790	1
9	DECAL, TRU-SHARP INFO	P12879	1
10	DECAL, BLADE ALIGNMENT INFO	P11789	1
11	DECAL, RED REFLECTIVE 2" ROUND	P07452	2
12	DECAL, HYDRAULIC	S12590	1
13	DECAL, HOT ENGINE WARNING	014419	1
14	DECAL, BLADE HOUSING COVER (DRIVE SIDE)	016243 ²	1
15	DECAL, BLADE HOUSING COVER (IDLE SIDE)	016242 ²	1
16	DECAL, BLADE HOUSING COVER (MIDDLE)	016244 ²	1

¹ Replaces S20039 decal originally supplied (5/00).
² Decal replaces silkscreen on blade housing covers beginning with Rev. H1.00.

4.11 Blade Housing Covers

LT30HD
LT40HD

Rev. G4.00 - J7.00
Rev. G4.00 - J8.00

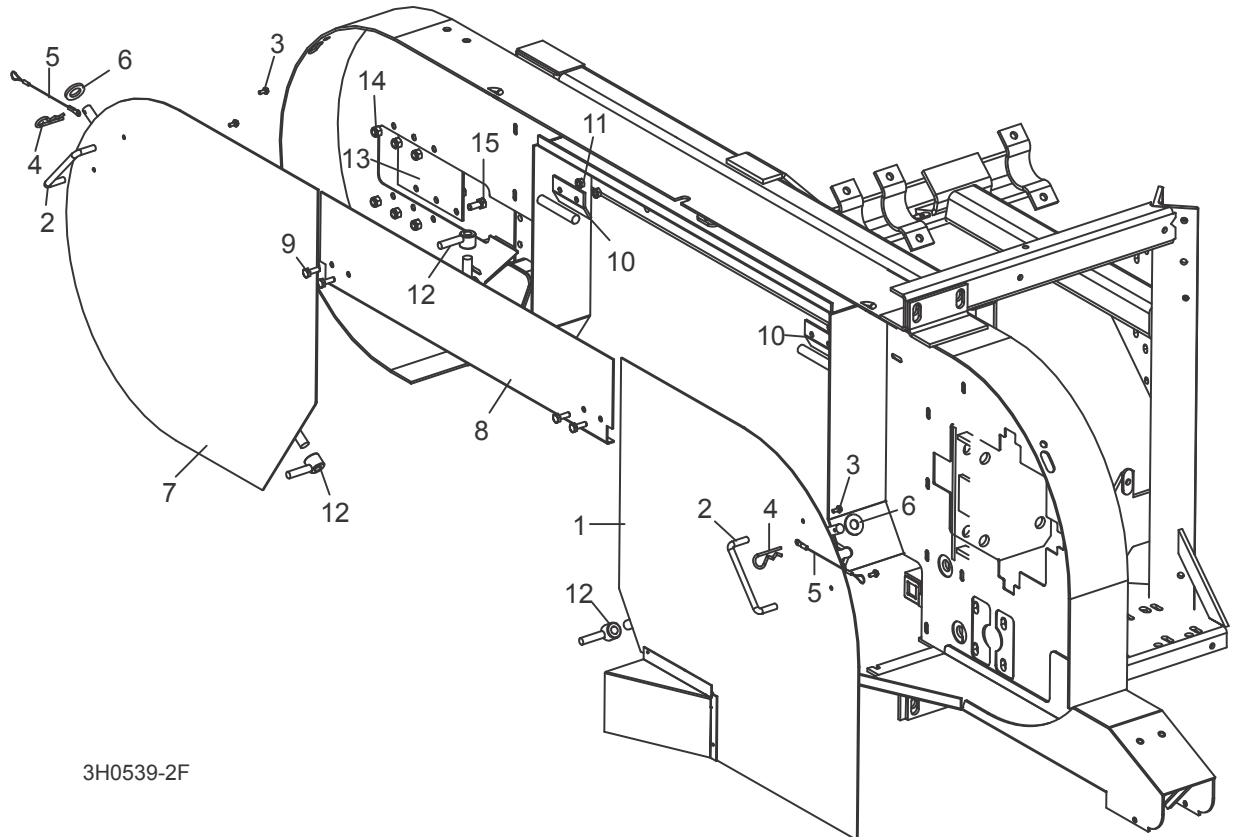

3H0539-2F

REF	DESCRIPTION (◆ Indicates Parts Available In Assemblies Only)	PART #	QTY.	
	COVER ASSEMBLY, DRIVE SIDE BLADE HOUSING WITH HANDLE	015937 ¹	1	
1	Cover, Drive Side Blade Housing (Includes Cover Decal - See Section 4.10)	015911	1	◆
2	Handle, Blade Housing Cover	P08065	1	
3	Screw, #8-32 X 3/8" Self-Tap	F05015-8	2	
	Pin Assembly, Cover Retainer	A12812 ²	1	
4	Pin, Safety Retainer	P05059	1	
5	Cable, 3/64" x 6" Lanyard	016030	1	
6	Washer, 1/2" ID x 1 1/8" OD x .093" Rubber	F05011-87 ³	1	
	COVER, IDLE SIDE BLADE HOUSING WITH HANDLE	A09419	1	
7	Cover, Idle Side Blade Housing (Includes Cover Decal - See Section 4.10)	W09351	1	◆
2	Handle, Blade Housing Cover	P08065	1	
3	Screw, #8-32 X 3/8" Self-Tap	F05015-8	2	
	Pin Assembly, Cover Retainer	A12812 ²	1	

4

Saw Head*Blade Housing Covers*

4	Pin, Safety Retainer	P05059	1	
5	Cable, 3/64" x 6" Lanyard	016030	1	
6	Washer, 1/2" ID x 1 1/8" OD x .093" Rubber	F05011-87 ³	1	
8	COVER, MIDDLE BLADE HOUSING	W07409	1	
9	BOLT, 1/4-20 X 3/4" HEX HEAD	F05005-1	18	
10	HINGE, MIDDLE BLADE HOUSING COVER	S07522	2	
11	NUT, 1/4-20 SELF-LOCKING HEX	F05010-9	4	
12	NUT, COVER TURN	021145	3	
13	PLATE, IDLE BLADE WHEEL GUARD	S04433	1	
14	NUT, 5/16-18 HEX NYLON LOCK	F05010-58	6	
15	BOLT, 5/16-18 X 3/4" HEX HEAD GRADE 2	F05006-5	6	

¹ Removed (1) 015734 Sawdust Exit Funnel and (7) F04203-8 1/8" x 1/8" Aluminum Pop Rivet and changed to welded funnel to improve durability (LT40HD Rev. K6.07).

² 016030 cable replaces R02075 cable and P11803 cable clamp originally supplied prior to LT30HD/40HD Rev. G6.02.

³ Added Rev. H3.00.

4.12 Blade Housing Covers

LT30HD
LT40HD

Rev. G1.00 - G3.00
Rev. G1.00 - G3.00

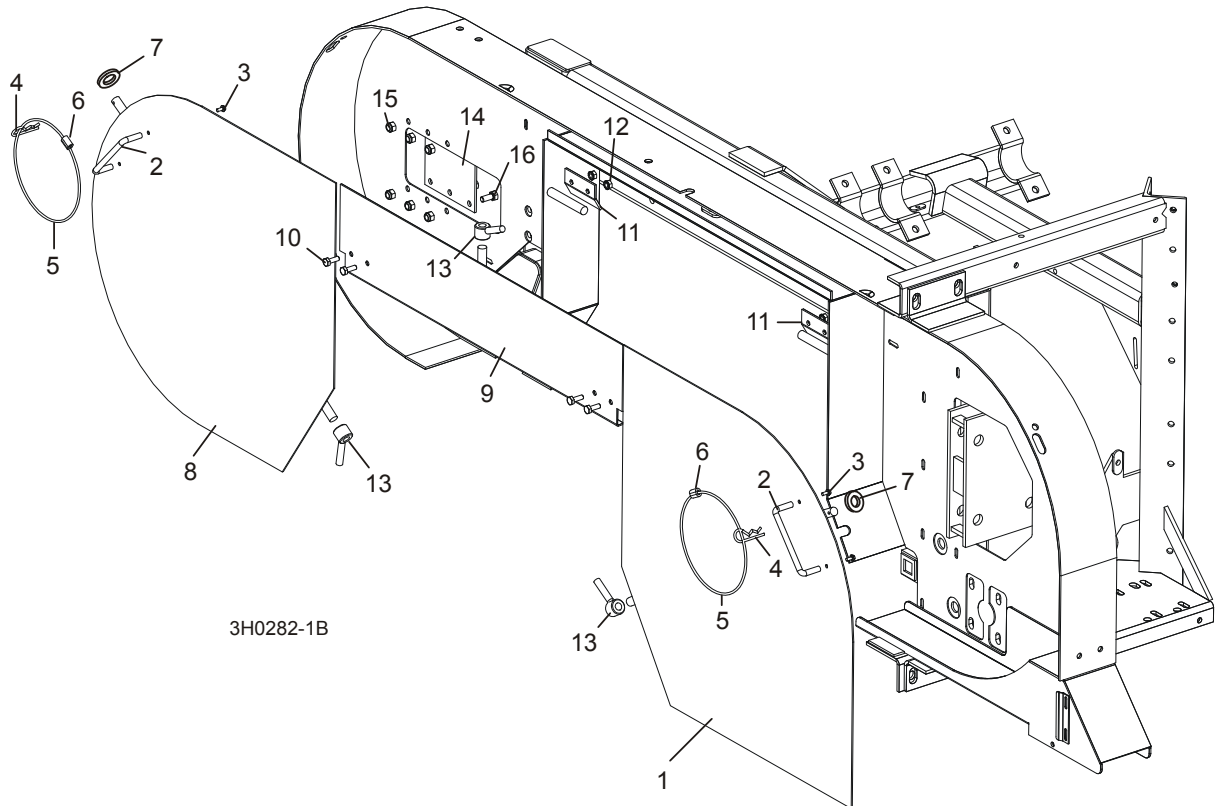

REF	DESCRIPTION (◆ Indicates Parts Available In Assemblies Only)	PART #	QTY.	
	COVER, DRIVE SIDE BLADE HOUSING WITH HANDLE	A09420	1	
1	Cover, Drive Side Blade Housing (Includes Cover Decal - See Section 4.10)	W07948	1	◆
2	Handle, Blade Housing Cover	P08065	1	
3	Screw, #8-32 X 3/8" Self-Tap	F05015-8	2	
	Pin Assembly, Cover Retainer	A12812 ¹	1	
4	Pin, Safety Retainer	P05059	1	
5	Cable, 1/8" O.D. Coated Nylon	R02075	.92 Ft.	◆
6	Clamp, 1/8" Dual Cable	P11830	1	◆
7	Washer, 1/2" ID x 1 1/8" OD x .093" Rubber	F05011-87 ²	1	
	COVER, IDLE SIDE BLADE HOUSING WITH HANDLE	A09419	1	
8	Cover, Idle Side Blade Housing (Includes Cover Decal - See Section 4.10)	W09351	1	◆
2	Handle, Blade Housing Cover	P08065	1	
3	Screw, #8-32 X 3/8" Self-Tap	F05015-8	2	
	Pin Assembly, Cover Retainer	A12812 ¹	1	

4

Saw Head*Blade Housing Covers*

4	Pin, Safety Retainer	P05059	1	
5	Cable, 1/8" O.D. Coated Nylon	R02075	.92 Ft.	
6	Clamp, 1/8" Dual Cable	P11830	1	
7	Washer, 1/2" ID x 1 1/8" OD x .093" Rubber	F05011-87 ²	1	
9	COVER, MIDDLE BLADE HOUSING	W07409	1	
10	BOLT, 1/4-20 X 3/4" HEX HEAD	F05005-1	18	
11	HINGE, MIDDLE BLADE HOUSING COVER	S07522	2	
12	NUT, 1/4-20 SELF-LOCKING HEX	F05010-9	4	
13	NUT, COVER TURN	021145 ³	3	
14	PLATE, IDLE BLADE WHEEL GUARD	S04433	1	
15	NUT, 5/16-18 HEX NYLON LOCK	F05010-58	6	
16	BOLT, 5/16-18 X 3/4" HEX HEAD GRADE 2	F05006-5	6	

¹ Cable R02075 and cable clamp P11830 obsolete. Replacement assembly A12812 includes new cable 016030 ([See Section 4.11](#)).

² Added 6/99.

³ Directly replaces W07511 nut weldment (8/97).

4.13 Drive Belt Covers

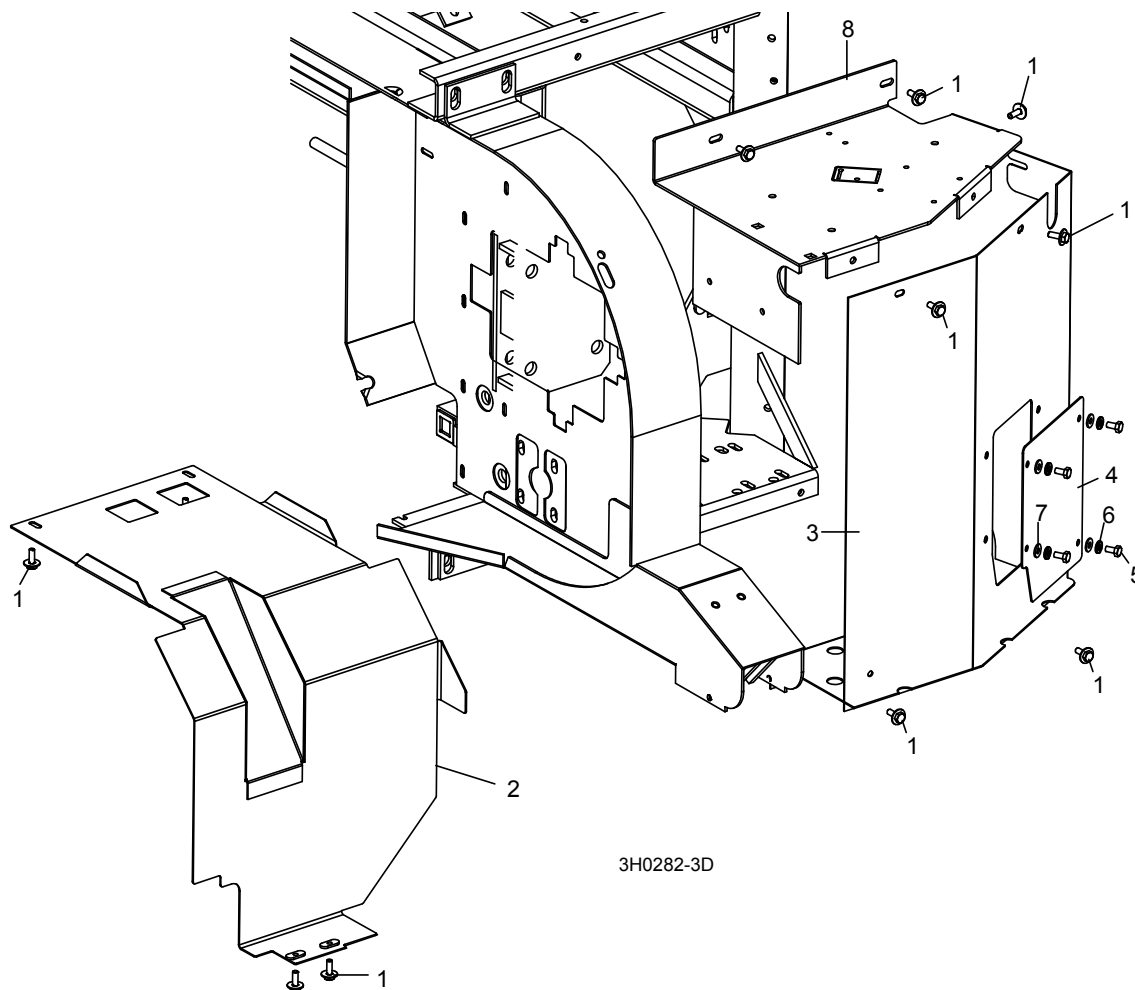

REF	DESCRIPTION (◆ Indicates Parts Available In Assemblies Only)	PART #	QTY.
1	BOLT, 1/4-20 X 3/4" HEX HEAD WITH CONICAL WASHER	F05005-134 ¹	11
2	GUARD, STANDARD LOWER DRIVE BELT	014241 ²	1
3	GUARD, DRIVE PULLEY SIDE	W11537 ³	1
4	PLATE, DRIVE PULLEY GUARD COVER	006870 ³	1
5	BOLT, 1/4-20 X 1/2" HEX HEAD	F05005-15	4
6	WASHER, 1/4" SPLIT LOCK	F05011-14	4
7	WASHER, 1/4" SAE FLAT	F05011-11	4
8	GUARD, DRIVE PULLEY TOP	W11750	1

¹ Replaces 1/4-20 x 3/4" hex head bolt (F05005-1) and 1/4" SAE flat washer (F05011-11) LT30HD/40HD rev. G9.00 and later.

² For sawmills equipped with standard manual clutch handle only. See Autoclutch Option manual for alternate guards.

³ Guard W11537 modified 3/09. Cutout added to accommodate Simple Set encoder sensor. Plate 006870 added to cover cutout on sawmills without Simple Set. Plate 006870 modified 10/09 to accommodate Super model covers.

4 Saw Head

Sawdust Chute

4.14 Sawdust Chute

LT30HD
LT40HD

Rev. G2.00 - J7.00
Rev. G2.00 - J8.00

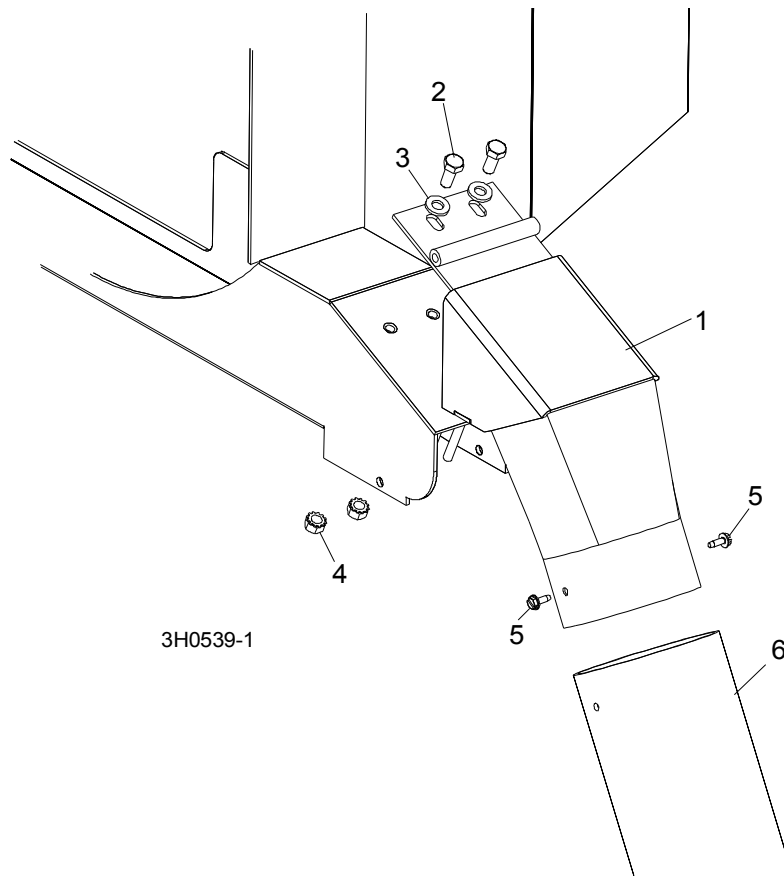

REF	DESCRIPTION (◆ Indicates Parts Available In Assemblies Only)	PART #	QTY.
1	CHUTE WELDMENT, SAWDUST	015466	1
2	BOLT, 5/16-18 X 3/4" HEX HEAD GRADE 2	F05006-5	2
3	WASHER, 5/16" SAE FLAT	F05011-17	2
4	NUT, 5/16-18 SELF-LOCKING HEX	F05010-20	2
5	BOLT, #10-24 X 1/2" SELF-TAPPING	F05015-7	2
6	TUBING, RUBBER SAWDUST	016727 ¹	1
	STRAP, 20" RUBBER W/HOOK	P11668	1
	BOLT, 1/4-20 X 1 1/4" HEX HEAD FULL THREAD	F05005-3	1
	WASHER, 1/4" SAE FLAT	F05011-11	1
	NUT, 1/4-20 LOCK	F05010-21	1

¹ Sawdust Chute 016727 replaces 4 ft. R02336 originally supplied prior to 1/01. New chute is cut at an angle to help prevent clogging.

4.15 Sawdust Chute

LT30HD
LT40HD

Rev. G1.00
Rev. G1.00

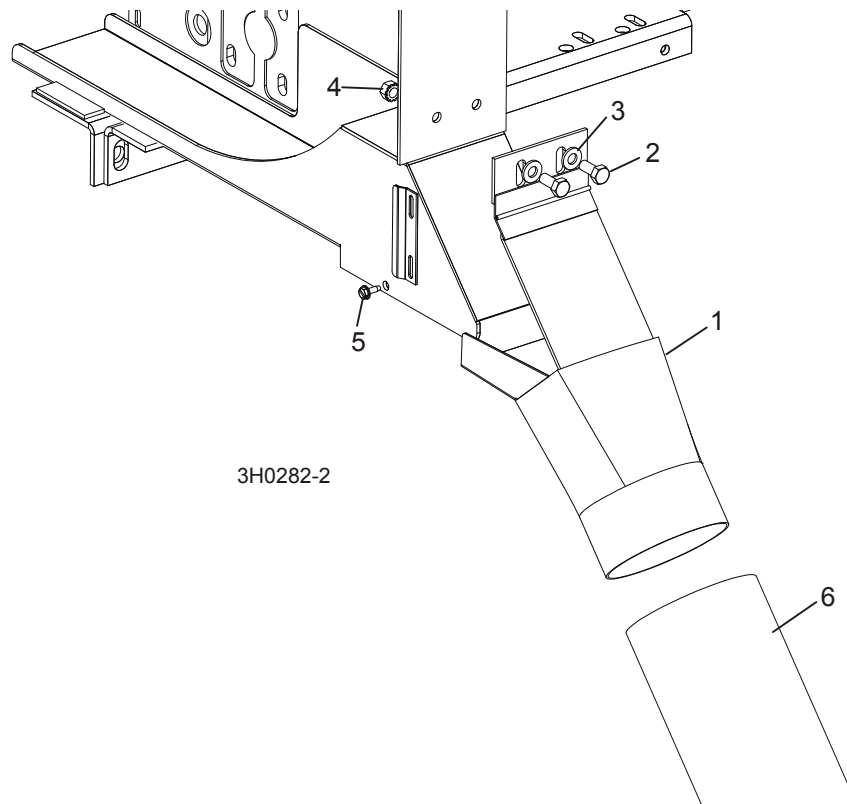

REF	DESCRIPTION (◆ Indicates Parts Available In Assemblies Only)	PART #	QTY.
1	CHUTE WELDMENT, SAWDUST	W12296	1
2	BOLT, 5/16-18 X 3/4" HEX HEAD GRADE 2	F05006-5	2
3	WASHER, 5/16" SAE FLAT	F05011-17	2
4	NUT, 5/16-18 SELF-LOCKING HEX	F05010-20	2
5	BOLT, #10-24 X 1/2" SELF-TAPPING	F05015-7	2
6	TUBING, RUBBER SAWDUST	016727 ¹	2 ft.
	STRAP, 20" RUBBER W/HOOK	P11668	1
	BOLT, 1/4-20 X 1 1/4" HEX HEAD FULL THREAD	F05005-3	1
	WASHER, 1/4" SAE FLAT	F05011-11	1
	NUT, 1/4-20 LOCK	F05010-21	1

¹ Sawdust Chute 016727 replaces 4 ft. R02336 originally supplied prior to 1/01. New chute is cut at an angle to help prevent clogging.

4 Saw Head
Debarker Wire Box/Hole Plugs

4.16 Debarker Wire Box/Hole Plugs

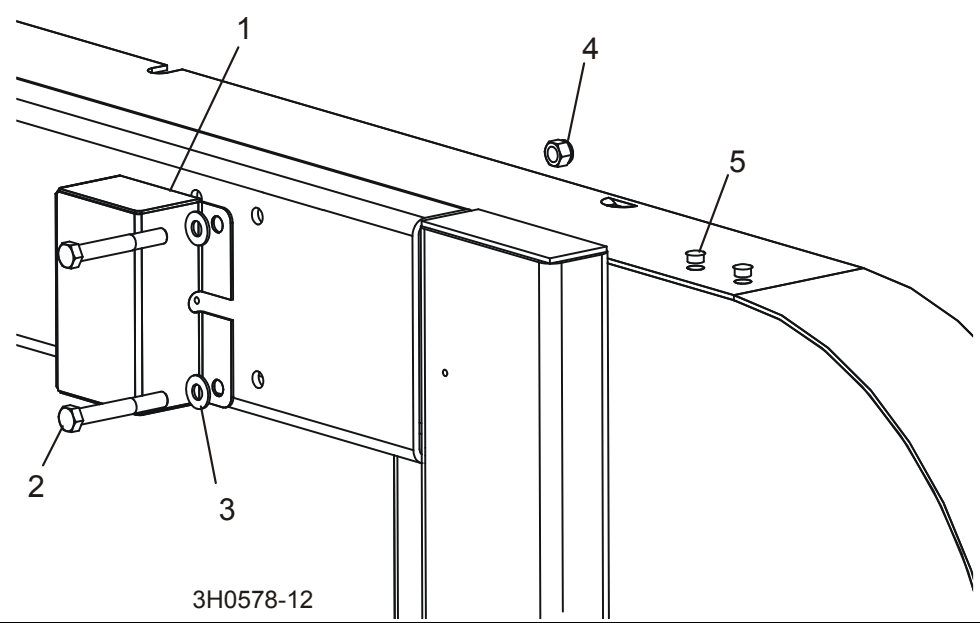

REF	DESCRIPTION (◆ Indicates Parts Available In Assemblies Only)	PART #	QTY.
1	BOX, DEBARKER WIRE STORAGE	023616	1
2	BOLT, 3/8-16 X 2 3/4" HEX HEAD	F05007-29	2
3	WASHER, 3/8" SAE FLAT	F05011-3	2
4	NUT, 3/8-16 HEX NYLON LOCK	F05010-10	2
5	PLUG, 13/32" PLASTIC HOLE	014537	2

SECTION 5 CONTROL & BATTERY BOXES

5.1 Control Assembly

LT30HD
LT40HD

Rev. J5.00 - J7.00
Rev. J6.00 - J8.00

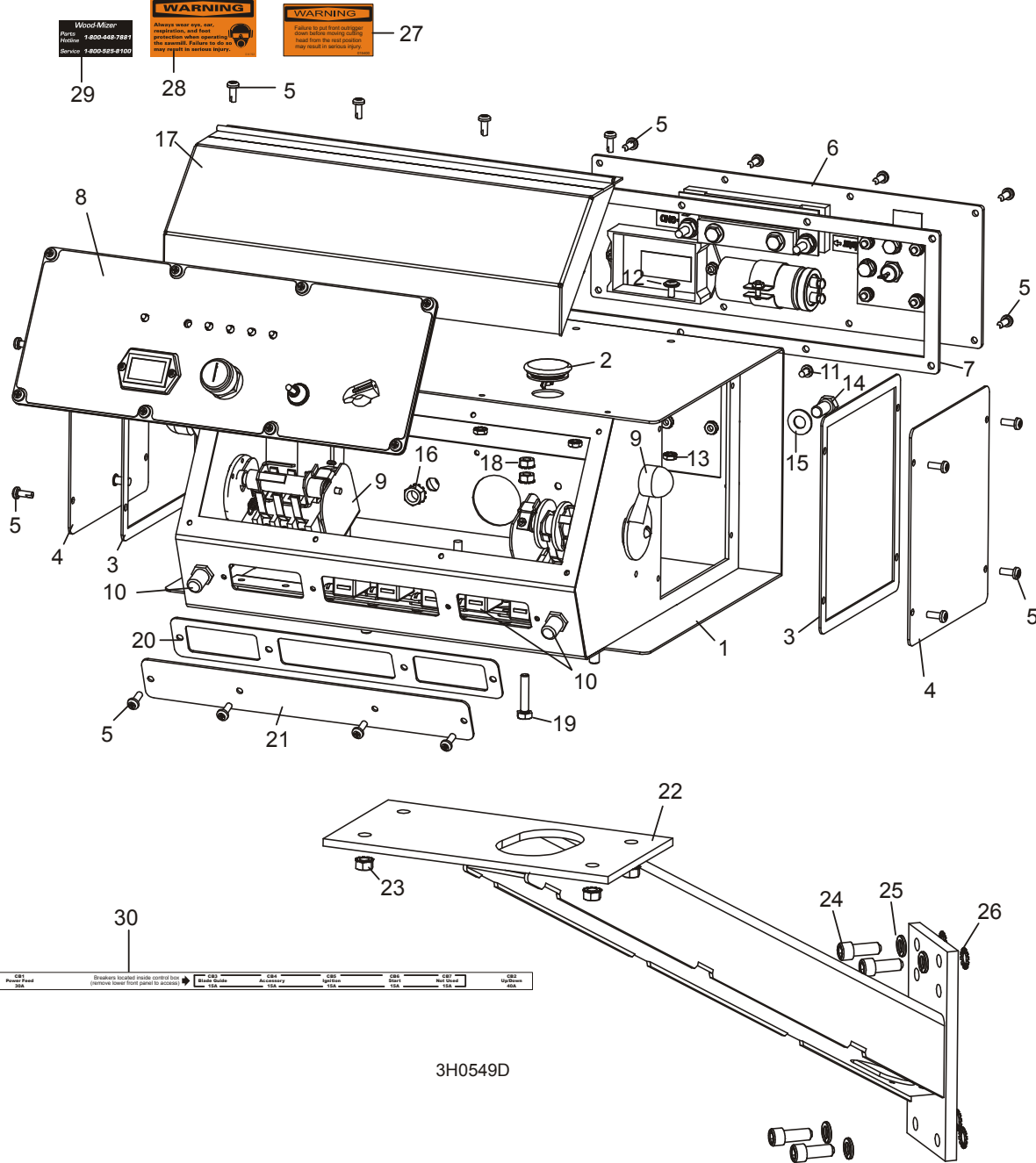

5 Control & Battery Boxes

Control Assembly

REF	DESCRIPTION (◆ Indicates Parts Available In Assemblies Only)	PART #	QTY.	
	CONTROL BOX ASSEMBLY, G28	051415	1	
	CONTROL BOX ASSEMBLY, G25	050686	1	
	CONTROL BOX ASSEMBLY, G36	050684	1	
	CONTROL BOX ASSEMBLY, D33	050685	1	
1	Box Weldment, Sawmill Control	016135	1	◆
2	Plug, AS075 Oiltite Painted	024250	1	
3	Gasket, Control Box Side Access	015274	2	
4	Panel Weldment, Control Box Side Access	015307	2	
5	Screw, #10-24 x 1/2" Pan Head	F05015-17	24	
6	Panel Assembly, Power Feed Control	024458	1	
	Control Module, Power Feed SMT	024396-1	1	
	Mosfet Module, Power Feed SMT	024387	1	
	Suppressor Assembly, Power Feed	052294 ¹	1	
	Capacitor Assembly, Power Feed Filter	051571	1	
	Diode Assembly, Power Feed Replacement	052363	1	
7	Gasket, Rear Access Panel	015278	1	
8	Front Control Panel & Wiring Harnesses (Section 5.6)			
9	Drum Switches (Section 5.4)			
10	Circuit Breakers (Section 5.5)			
11	Screw, #10-24 x 3/8" Phillips Pan Head	F05004-3	2	
12	Screw, #10-24 x 3/8" Phillips Pan Head Machine with Neo Washer	F05004-148	4	
13	Nut, #10-24 Self Locking	F05010-14	6	
14	Bolt, 3/8-16 x 3/4" Hex Head	F05007-27	2	
15	Washer, 3/8" SAE Flat	F05011-3	2	
16	Nut, 3/8" Lock Nut	F05010-19	2	
17	Cover, Control Box Hinged	015304	1	
18	Nut, 1/4-20 Self Locking	F05010-9	2	
19	Bolt, 1/4-20 x 1 1/2" Hex Head	f05005-5	1	
20	Gasket, Front Access Panel	015266	1	
21	Panel, Control Box Front Access	015376	1	
22	MOUNT WELDMENT, STANDARD CONTROL BOX	015236	1	
23	NUT, 5/16-18 SELF-LOCKING HEX	F05010-20	4	
24	BOLT, 3/8-16 X 1" SOCKET HEAD	F05007-52	4	
25	WASHER, 3/8" SPLIT LOCK	F05011-4	4	
26	WASHER, 3/8" EXTERIOR STAR LOCK	F05011-36	4	
27	DECAL, FRONT OUTRIGGER WARNING	015400	1	
28	DECAL, EAR/EYE PROTECTION WARNING	S11753	1	
29	DECAL, 800 NUMBER	S12117	1	
30	DECAL, CIRCUIT BREAKER ID ('98 STD)	024361	1	

¹ Suppressor Assembly 052294 added 6/05 to protect feed circuit.

5.2 Control Assembly

LT30HD
LT40HD

Rev. G6.00 - J4.00
Rev. G6.00 - J5.00

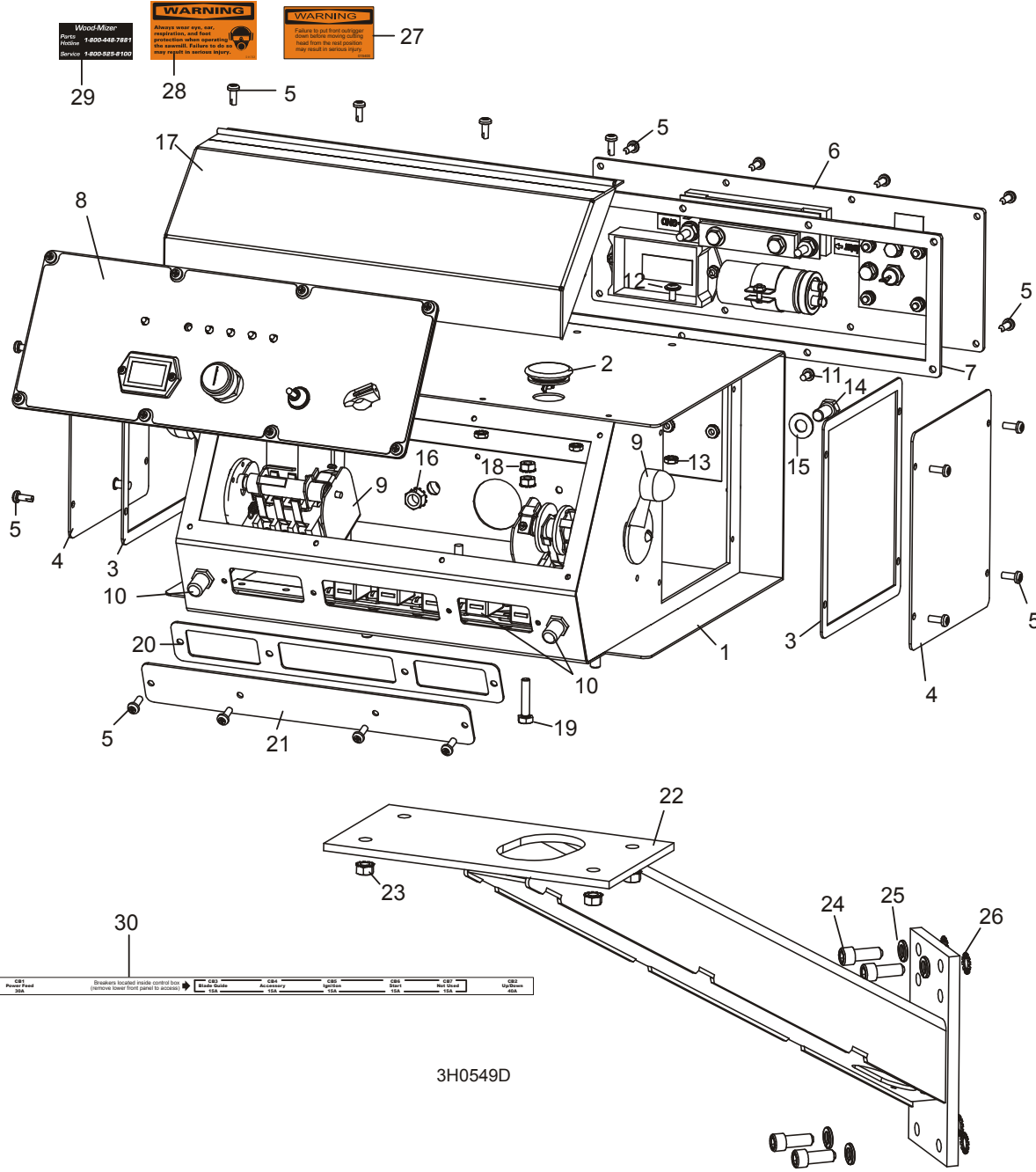

5 Control & Battery Boxes

Control Assembly

REF	DESCRIPTION (◆ Indicates Parts Available In Assemblies Only)	PART #	QTY.	
	CONTROL BOX ASSEMBLY, G25	024306	1	
	CONTROL BOX ASSEMBLY, G36	016647	1	
	CONTROL BOX ASSEMBLY, D33	024601	1	
	CONTROL BOX ASSEMBLY, D30	015402	1	
1	Box Weldment, Sawmill Control	016135 ¹	1	◆
2	Plug, AS075 Oiltite Painted	024250 ²	1	
3	Gasket, Control Box Side Access	015274	2	
4	Panel Weldment, Control Box Side Access	015307	2	
5	Screw, #10-24 x 1/2" Pan Head	F05015-17	24	
6	Panel Assembly, Power Feed Control	024458 ³	1	
	Control Module, Power Feed SMT	024396-1	1	
	Mosfet Module, Power Feed SMT	024387	1	
	Suppressor Assembly, Power Feed	052294 ⁴	1	
	Capacitor Assembly, Power Feed Filter	051571	1	
	Diode Assembly, Power Feed Replacement	052363	1	
7	Gasket, Rear Access Panel	015278	1	
8	Front Control Panel & Wiring Harnesses (Section 5.7)			
9	Drum Switches (Section 5.4)			
10	Circuit Breakers (Section 5.5)			
11	Screw, #10-24 x 3/8" Phillips Pan Head	F05004-3	2	
12	Screw, #10-24 x 3/8" Phillips Pan Head Machine with Neo Washer	F05004-148	4	
13	Nut, #10-24 Self Locking	F05010-14	6	
14	Bolt, 3/8-16 x 3/4" Hex Head	F05007-27	2	
15	Washer, 3/8" SAE Flat	F05011-3	2	
16	Nut, 3/8" Lock Nut	F05010-19	2	
17	Cover, Control Box Hinged	015304	1	
18	Nut, 1/4-20 Self Locking	F05010-9	2	
19	Bolt, 1/4-20 x 1 1/2" Hex Head	f05005-5	1	
20	Gasket, Front Access Panel	015266	1	
21	Panel, Control Box Front Access	015376	1	
22	MOUNT WELDMENT, STANDARD CONTROL BOX	015236	1	
23	NUT, 5/16-18 SELF-LOCKING HEX	F05010-20	4	
24	BOLT, 3/8-16 X 1" SOCKET HEAD	F05007-52	4	
25	WASHER, 3/8" SPLIT LOCK	F05011-4	4	
26	WASHER, 3/8" EXTERIOR STAR LOCK	F05011-36	4	
27	DECAL, FRONT OUTRIGGER WARNING	015400	1	
28	DECAL, EAR/EYE PROTECTION WARNING	S11753	1	
29	DECAL, 800 NUMBER	S12117	1	
30	DECAL, CIRCUIT BREAKER ID ('98 STD)	024361	1	

¹ Directly replaces control box weldment 015351 (2/99).

² Replaces E20570 unpainted plug.

- ³ 024458 Power Feed Control Panel Assembly replaces 015410 originally supplied prior to LT30HD/LT40HD Rev. G9.00. New assembly features modularized components and surface mount technology to improve durability and power capability.
- ⁴ Suppressor Assembly 052294 added 6/05 to protect feed circuit.

5.3 Control Assembly

LT30HD
LT40HD

Rev. G1.00 - G5.02
Rev. G1.00 - G5.00

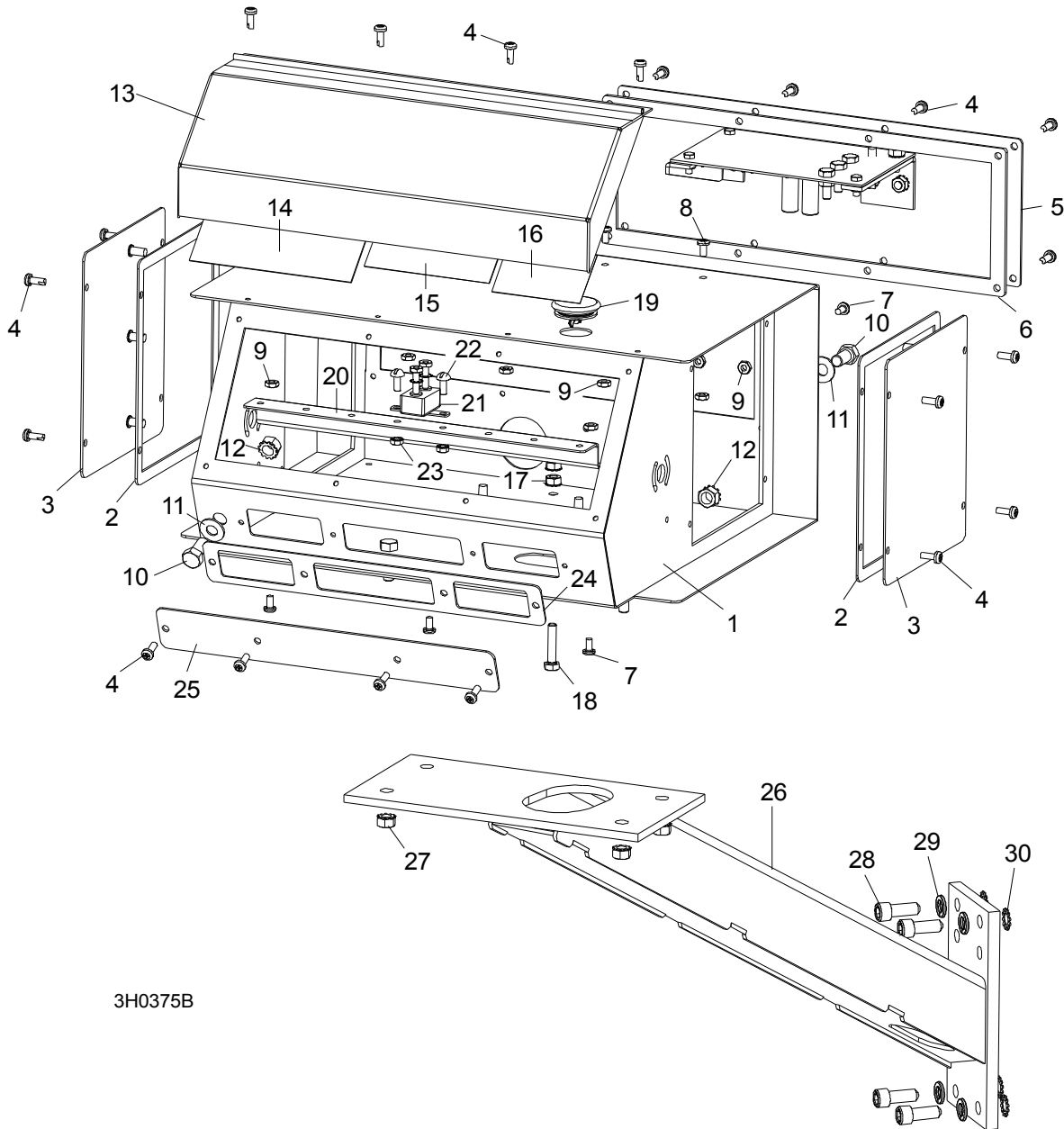

3H0375B

REF	DESCRIPTION (◆ Indicates Parts Available In Assemblies Only)	PART #	QTY.	
	CONTROL BOX ASSEMBLY, G25 (Includes Parts In Section 5.4 & Section 5.8)	024306 ¹	1	
	CONTROL BOX ASSEMBLY, G24 (Includes Parts In Section 5.4 & Section 5.8)	015404	1	
	CONTROL BOX ASSEMBLY, D30 (Includes Parts In Section 5.4 & Section 5.8)	015402 ¹	1	
1	Box Weldment, Sawmill Control	016135 ²	1	◆
2	Gasket, Control Box Side Access	015274	2	
3	Panel Weldment, Control Box Side Access	015307	2	
4	Screw, #10-24 x 1/2" Pan Head	F05015-17	24	
5	Panel Assembly, Power Feed Control	024458 ³	1	
	Control Module, Power Feed SMT	024396-1	1	
	Mosfet Module, Power Feed SMT	024387	1	
	Suppressor Assembly, Power Feed	052294 ⁴	1	
	Capacitor Assembly, Power Feed Filter	051571	1	
	Diode Assembly, Power Feed Replacement	052363	1	
6	Gasket, Rear Access Panel	015278	1	
7	Screw, #10-24 x 3/8" Phillips Pan Head	F05004-3	5	
8	Screw, #10-24 x 3/8" Phillips Pan Head Machine with Neo Washer	F05004-148 ⁵	4	
9	Nut, #10-24 Self Locking	F05010-14	9	
10	Bolt, 3/8-16 x 3/4" Hex Head	F05007-27	2	
11	Washer, 3/8" SAE Flat	F05011-3	2	
12	Nut, 3/8" Lock Nut	F05010-19	2	
13	Cover, Control Box Hinged	015304	1	
14	Decal, Keep Away Hydraulic Warning (LT30HD/40HD Only)	P12961	1	
15	Decal, Ear/Eye Protection Warning	S11753	1	
16	Decal, Front Outrigger Warning	015400	1	
17	Nut, 1/4-20 Self Locking	F05010-9	2	
18	Bolt, 1/4-20 x 1 1/2" Hex Head	f05005-5	1	
19	Plug, AS075 Oiltite Painted	024250 ⁶	1	
	Breaker Assembly, Sawmill Control Circuit	015412 ¹	1	
20	Rail, Circuit Breaker	015310	1	
21	Breaker, 30 Amp Auto Reset	E20486	1	
22	Screw, #8-32 X 1/2" Slotted Head	F05004-12	2	
23	Nut, #8-32 Hex Self-Locking	F05010-41	2	
24	Gasket, Front Access Panel	015266	1	
25	Panel, Control Box Front Access	015376	1	
26	MOUNT WELDMENT, STANDARD CONTROL BOX	015236	1	
27	NUT, 5/16-18 SELF-LOCKING HEX	F05010-20	4	
28	BOLT, 3/8-16 X 1" SOCKET HEAD	F05007-52	4	
29	WASHER, 3/8" SPLIT LOCK	F05011-4	4	
30	WASHER, 3/8" EXTERIOR STAR LOCK	F05011-36	4	

¹ Control box revised with manual reset circuit breakers for each circuit branch on LT30HD and LT40HD Rev. G6.00. Front panel, drum switch, and harnesses updated for new circuit breakers ([See Section 5.1](#)).



Control & Battery Boxes

Control Assembly

² Directly replaces control box weldment 015351 (2/99).

³ 024458 Power Feed Control Panel Assembly replaces 015410 originally supplied. New assembly features modularized components and surface mount technology to improve durability and power capability.

⁴ Suppressor Assembly 052294 added 6/05 to protect feed circuit.

⁵ New screw includes rubber washer to better seal holes; directly replaces F05004-3 (1/98).

⁶ Replaces E20570 unpainted plug.

5.4 Drum Switches

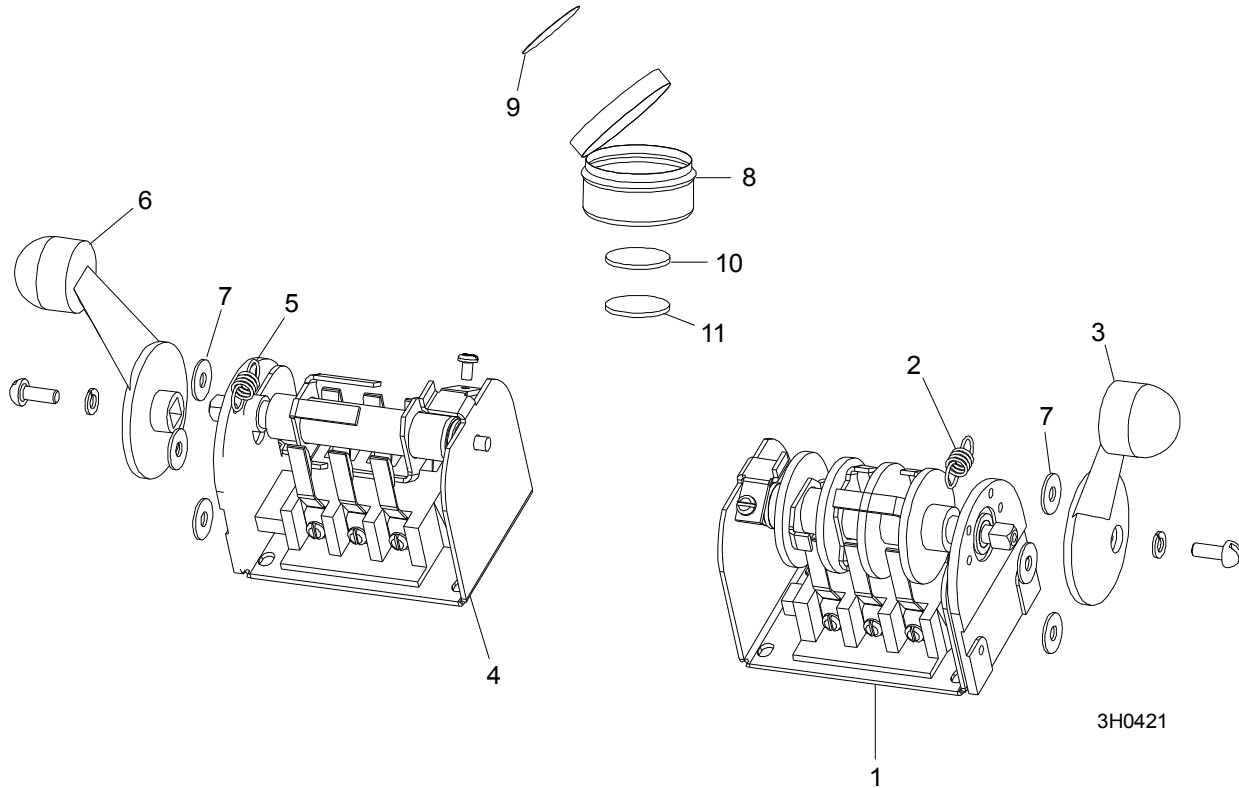

REF	DESCRIPTION (◆ Indicates Parts Available In Assemblies Only)	PART #	QTY.	
	SWITCH ASSEMBLY, UP/DOWN DRUM	E20440	1	
1	Switch, S12 Bulk Drum	E20440-B	1	◆
2	Spring, Drum Switch	P12570	1	
3	Handle, Drum Switch Replacement	P12500	1	
	SWITCH ASSEMBLY, POWER FEED DRUM	E20439	1	
4	Switch, S11 Bulk Drum	E20439-B	1	◆
5	Spring, Drum Switch	P12570	1	
6	Handle, Drum Switch Replacement	P12500	1	
7	WASHER, #8 SAE FLAT	F05011-41	6	
	CUP ASSEMBLY, DRUM SWITCH GREASE	A20463	1	
8	Cup, Plastic Container	P20464	1	◆
9	Decal, Grease Cup Label	P20467	1	
10	Pad, Velcro Loop	P20466	1	◆
11	Pad, Velcro Hook	P20465	1	◆
	Grease, High Temp Drum Switch	P20468	.025 Lb	◆

5.5 Circuit Breakers

LT30HD
LT40HD

Rev. G6.00 - J7.00
Rev. G6.00 - J8.00

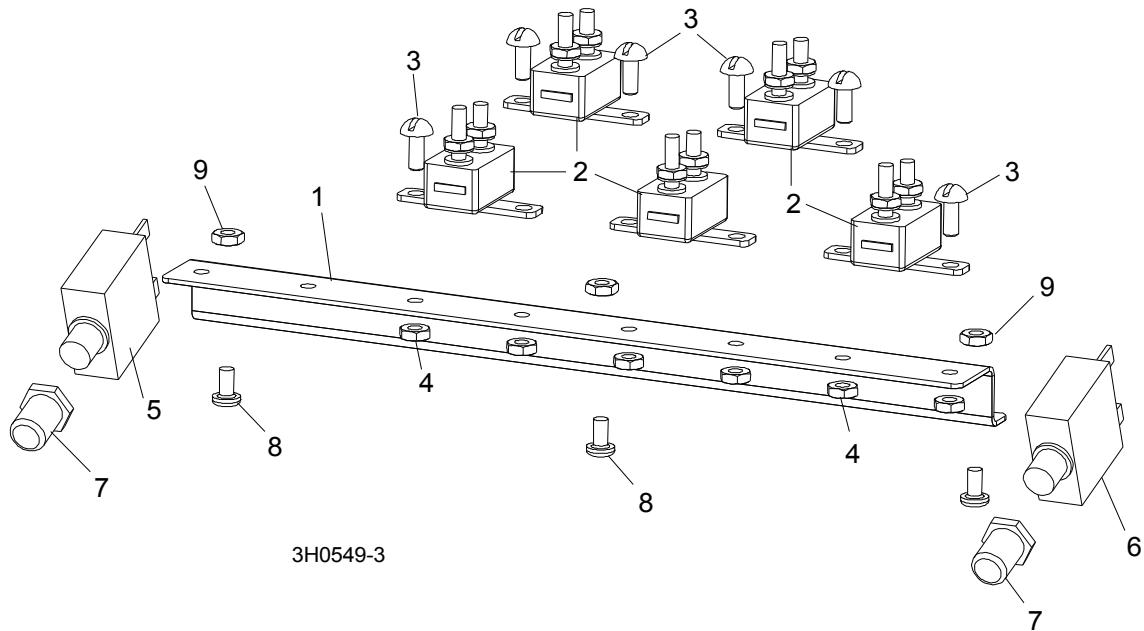

REF	DESCRIPTION (◆ Indicates Parts Available In Assemblies Only)	PART #	QTY.
	BREAKER ASSEMBLY, SAWMILL CONTROL CIRCUIT (DC)	015621 ¹	1
1	Rail, Circuit Breaker	015310	1
2	Breaker, 15 Amp Manual Reset	E20430	5
3	Screw, #8-32 X 1/2" Slotted Head	F05004-12	6
4	Nut, #8-32 Hex Self-Locking	F05010-41	6
5	BREAKER, 40 AMP MANUAL RESET PANEL MOUNT	051981 ²	1
6	BREAKER, 40 AMP MANUAL RESET PANEL MOUNT	051981 ³	1
7	BOOT, CIRCUIT BREAKER	021253	2
8	SCREW, #10-24 X 3/8" PHILLIPS PAN HEAD	F05004-3	3
9	NUT, #10-24 SELF LOCKING	F05010-14	3

¹ Circuit Breaker Assembly modified 12/06. New rail 052826 used to accept #10-24 x 1/2" Self-Tapping Screws F05015-7.

² 40A Breaker 051981 replaces 30A Breaker 024246 for Fwd/Rev Circuit to reduce nuisance tripping (1/05).

³ 40A Breaker 051981 replaces 30A Breaker 024246 for Up/Down Circuit to reduce nuisance tripping (9/04).

5.6 Front Panel Assembly & Harnesses

LT30HD
LT40HD

Rev. J5.00 - J7.00
Rev. J6.00 - J8.00

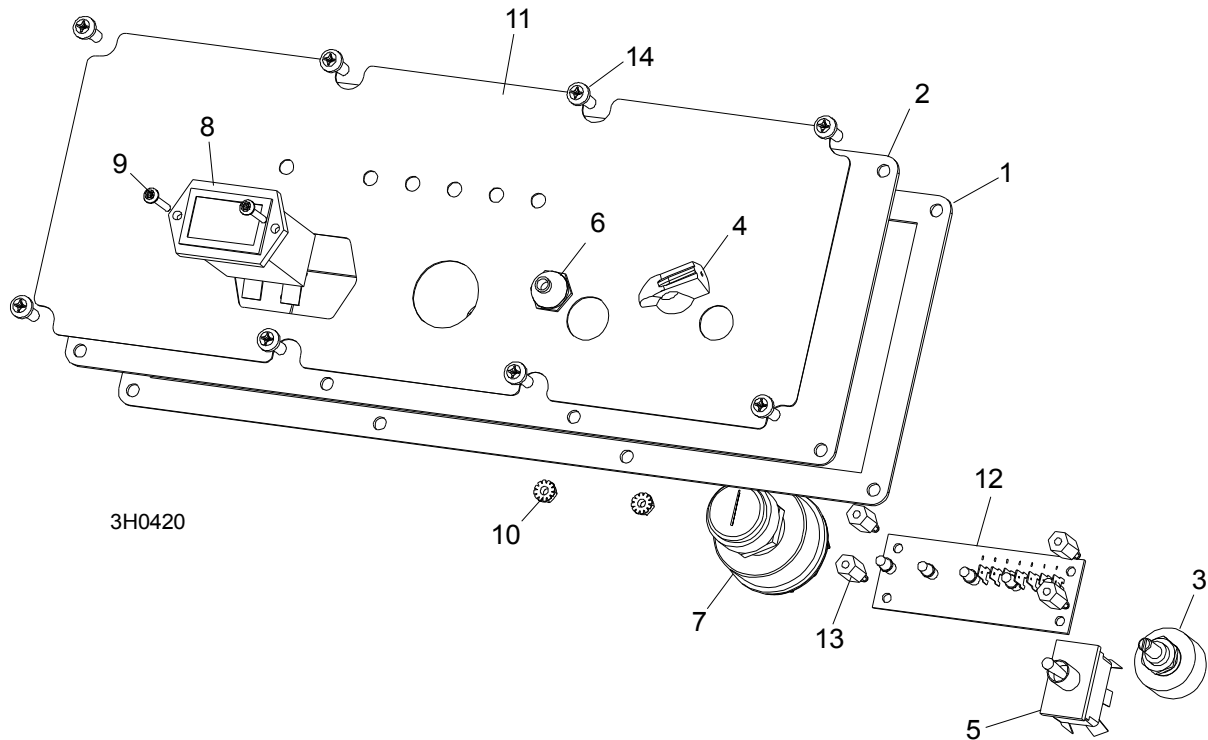

REF	DESCRIPTION (◆ Indicates Parts Available In Assemblies Only)	PART #	QTY.	
	PANEL ASSEMBLY, CONTROL FRONT (G25/G28)	024210	1	◆
	PANEL ASSEMBLY, CONTROL FRONT (D33/G36)	024211	1	◆
1	Gasket, Front Panel	015270	1	
2	Panel Weldment, Control	015302	1	
3	Switch Assembly, Feed Rate	024450-1	1	
4	Knob, Feed Rate With Set Screw	P06257	1	
5	Switch, Toggle	024200	1	
6	Boot, Toggle Switch Rubber	P02575	1	
7	Switch, Key	P04350	1	
8	Meter, Hour	015401	1	
9	Screw, 6-42 x 3/4" Socket Button Head Cap Stainless Steel	F05004-93	2	
10	Nut, 6-23 Self Locking	F05010-59	2	
11	Decal, Control Panel (G25)	015271	1	
	Decal, Control Panel (D33)	015269	1	
12	Board, LED Circuit (G25)	015416	1	
	Board, LED Circuit (D33)	015409	1	
13	Spacer, 1/2"-#6 Threaded	023147	4	
14	SCREW, #10-24 X 1/2" PAN HEAD	F05015-17	8	

5

Control & Battery Boxes

Front Panel Assembly & Harnesses

	HARNESS ASSEMBLY, UPPER WIRING (G36)	024886	1	
	HARNESS ASSEMBLY, UPPER WIRING (G28)	051414	1	
	HARNESS ASSEMBLY, UPPER WIRING (G25)	024307	1	
	HARNESS ASSEMBLY, UPPER WIRING (D33)	024602	1	
	Conduit, 1 1/4" x 58" Flex	050399	1	
	Connector, 1 1/4" Straight Male Metal Conduit	024402	1	
	HARNESS ASSEMBLY, LOWER WIRING (G25/G28)	050679	1	
	HARNESS ASSEMBLY, LOWER WIRING (D33/G36)	050678	1	
	Conduit, 1/2" Expandable Black	R02374	41 in.	
	Conduit, 1/2" Expandable Black	R02374	42 in.	

5.7 Front Panel Assembly & Harnesses

LT30HD
LT40HD

Rev. G3.00 - J4.00
Rev. G3.00 - J5.00

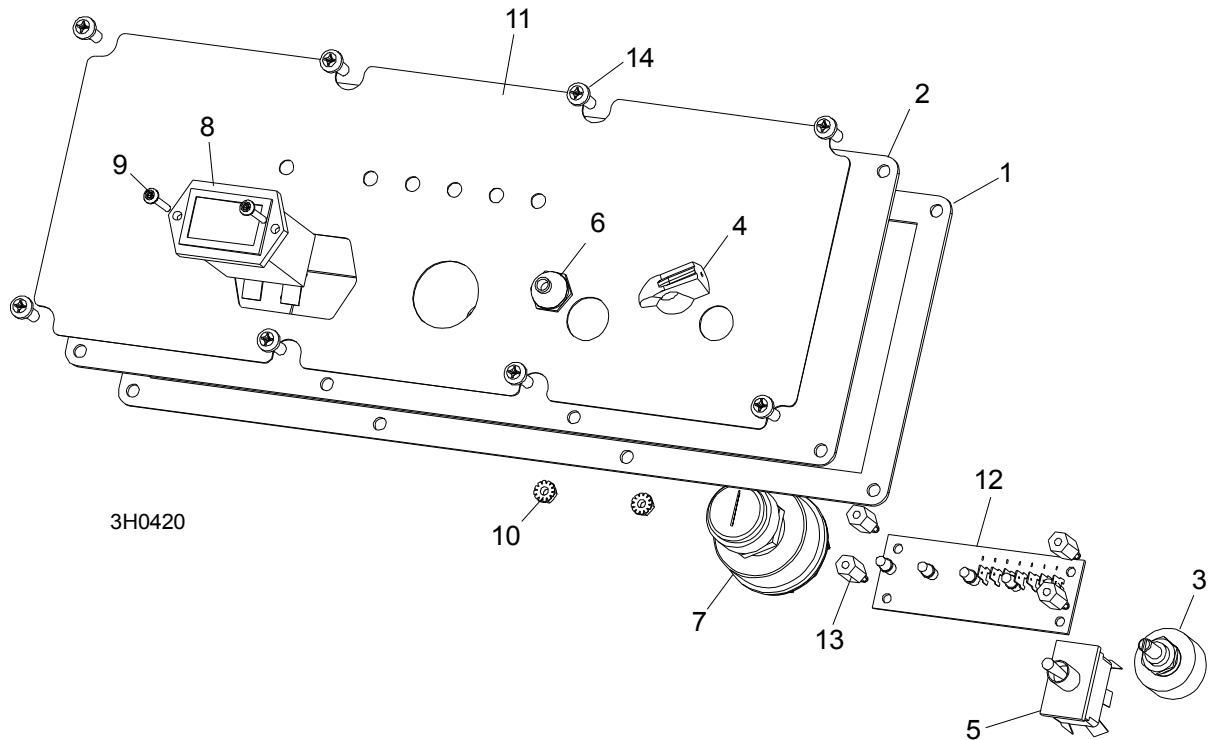

REF	DESCRIPTION (◆ Indicates Parts Available In Assemblies Only)	PART #	QTY.	
	PANEL ASSEMBLY, CONTROL FRONT (G24/G25)	024210 ¹	1	◆
	PANEL ASSEMBLY, CONTROL FRONT (D30/D33/G36)	024211 ¹	1	◆
1	Gasket, Front Panel	015270	1	
2	Panel Weldment, Control	015302	1	
3	Switch Assembly, Feed Rate	024450-1 ²	1	
4	Knob, Feed Rate With Set Screw	P06257	1	
5	Switch, Toggle	024200	1	
6	Boot, Toggle Switch Rubber	P02575	1	
7	Switch, Key	P04350	1	
8	Meter, Hour	015401	1	
9	Screw, 6-42 x 3/4" Socket Button Head Cap Stainless Steel	F05004-93	2	
10	Nut, 6-23 Self Locking	F05010-59	2	
11	Decal, Control Panel (G24/G25)	015271	1	
	Decal, Control Panel (D30/D33)	015269	1	
12	Board, LED Circuit (G24/G25)	015416	1	
	Board, LED Circuit (D30/D33)	015409	1	
13	Spacer, 1/2"-#6 Threaded	023147	4	

5

Control & Battery Boxes Front Panel Assembly & Harnesses

14	SCREW, #10-24 X 1/2" PAN HEAD	F05015-17	8	
	HARNESS ASSEMBLY, UPPER WIRING (G36)	024886	1	
	HARNESS ASSEMBLY, UPPER WIRING (G25)	024307 ³	1	
	HARNESS ASSEMBLY, UPPER WIRING (G24)	024215 ³	1	
	HARNESS ASSEMBLY, UPPER WIRING (D30)	024217 ³	1	
	HARNESS ASSEMBLY, UPPER WIRING (D33)	024602	1	
	Conduit, 1 1/4" x 58" Flex	050399	1	
	Connector, 1 1/4" Straight Male Metal Conduit	024402	1	
	HARNESS ASSEMBLY, LOWER WIRING (G24/G25)	015421	1	
	HARNESS ASSEMBLY, LOWER WIRING (D30/D33/G36)	015414	1	
	Conduit, 1/2" Expandable Black	R02374	41 in.	
	Conduit, 1/2" Expandable Black	R02374	42 in.	

¹ Control box revised with manual reset circuit breakers for each circuit branch on LT30HD and LT40HD Rev. G6.00. Front panel, drum switch, and harnesses updated for new circuit breakers ([See Section 5.2](#)).

² 024450-1 Feed Rate Switch Assembly replaces 015408 originally supplied prior to LT30HD/LT40HD Rev. G9.00.

³ Harness 1 1/4" Maxiflex conduit R01633 replaced with 024401 1 1/4" PMA Flex to provide better flexibility in subzero temperatures. Plastic connector 014447 replaced with metal connector 024402 to avoid stripping of connector threads. Harness changes effective with LT30HD and LT40HD Rev. G6.05. New harness conduit and connector may be used to replace components of previous revision sawmills.

5.8 Front Panel Assembly & Harnesses

LT30HD
LT40HD

Rev. G1.00 - G2.05
Rev. G1.00 - G2.05

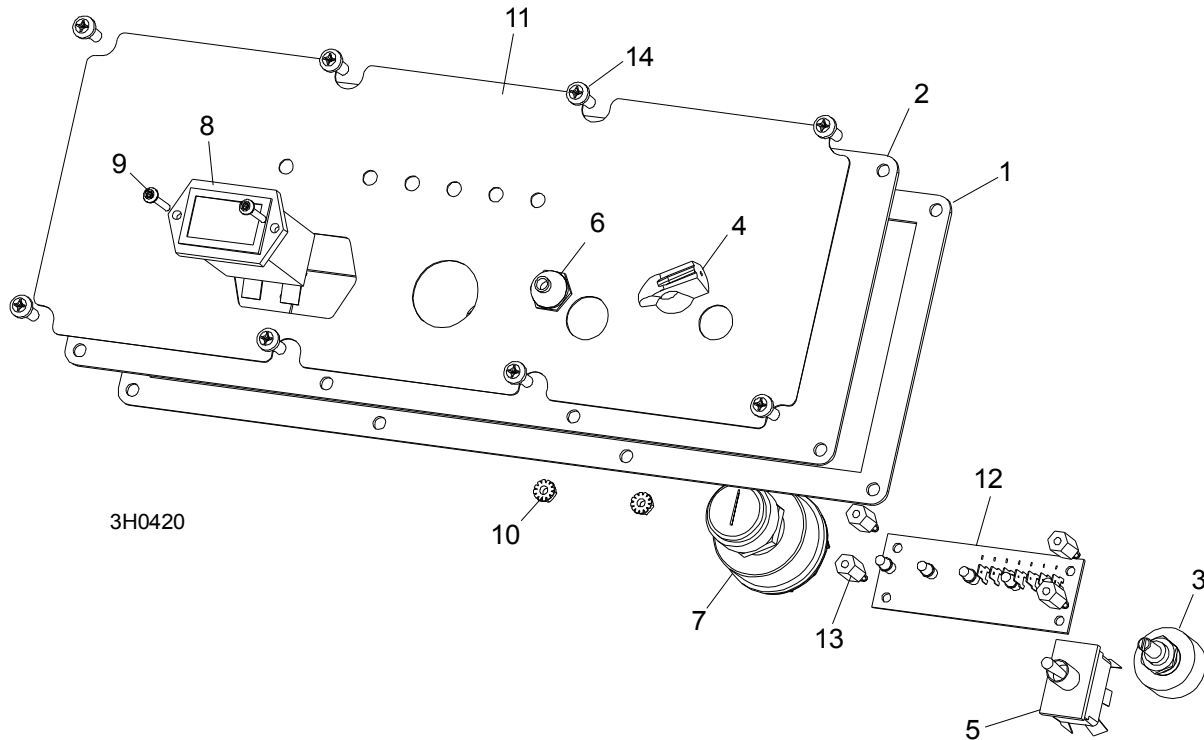

REF	DESCRIPTION (◆ Indicates Parts Available In Assemblies Only)	PART #	QTY.	
	PANEL ASSEMBLY, CONTROL FRONT (G24)	015415 ¹	1	◆
	PANEL ASSEMBLY, CONTROL FRONT (D30)	015407	1	◆
1	Gasket, Front Panel	015270	1	
2	Panel Weldment, Control	015302	1	
3	Switch Assembly, Feed Rate	024450-1 ²	1	
4	Knob, Feed Rate With Set Screw	P06257	1	
5	Switch, Toggle	P10006 ¹	1	
6	Boot, Toggle Switch Rubber	P02575	1	
7	Switch, Key	P04350	1	
8	Meter, Hour	015401	1	
9	Screw, 6-42 x 3/4" Socket Button Head Cap Stainless Steel	F05004-93	2	
10	Nut, 6-23 Self Locking	F05010-59	2	
11	Decal, Control Panel (G24)	015271	1	
	Decal, Control Panel (D30)	015269	1	
12	Board, LED Circuit (G24)	015416	1	
	Board, LED Circuit (D30)	015409	1	
13	Spacer, 1/2"-#6 Threaded	023147	4	

5 Control & Battery Boxes

Front Panel Assembly & Harnesses

14	SCREW, #10-24 X 1/2" PAN HEAD	F05015-17	8	
	HARNESS ASSEMBLY, UPPER WIRING (G24)	015420 ¹	1	
	HARNESS ASSEMBLY, UPPER WIRING (D30)	015413 ¹	1	
	Conduit, 1 1/4" x 58" Flex	050399	1	
	Connector, 1 1/4" Straight Male Metal Conduit	024402	1	
	HARNESS ASSEMBLY, LOWER WIRING (G24)	015421	1	
	HARNESS ASSEMBLY, LOWER WIRING (D30)	015414	1	
	Conduit, 1/2" Expandable Black	R02374	41 in.	
	Conduit, 1/2" Expandable Black	R02374	42 in.	

¹ Front panel and upper wiring harnesses replaced with new panel with quick connect blade guide toggle switch on LT30HD and LT40HD Rev. G3.00 ([See Section 5.6](#)). Use toggle switch P10006 for original panel/harness with screw terminals.

² 024450-1 Feed Rate Switch Assembly replaces 015408 originally supplied.

5.9 Battery Box Assembly

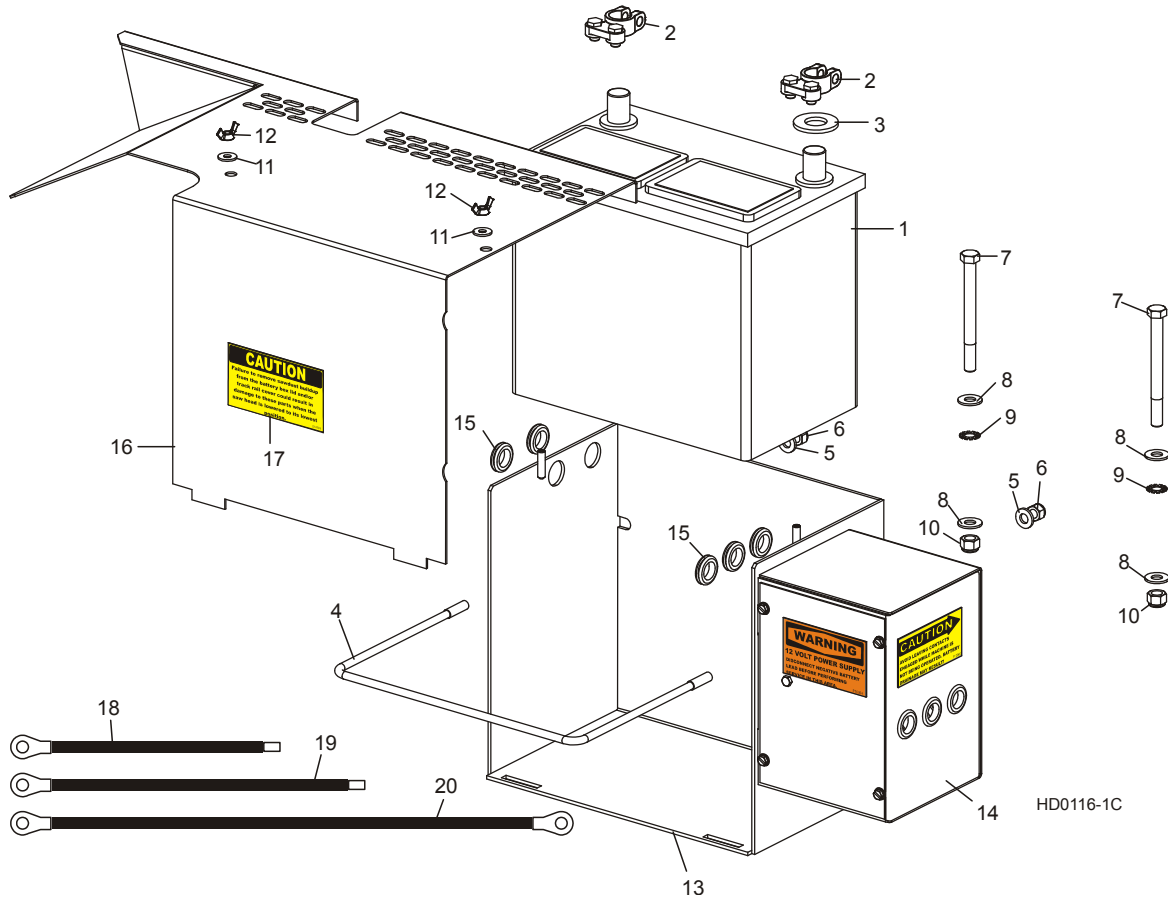

REF	DESCRIPTION (◆ Indicates Parts Available In Assemblies Only)	PART NUMBER	QTY.	
1	BATTERY, 12 VOLT 8800MF	P12315	1	◆
	BOX ASSEMBLY, LT30HD/LT40HD BATTERY	015471 ¹	1	
2	Terminal, Battery	P05085	2	
3	Washer, Battery Terminal	P12161	1	
4	Retainer Loop, Battery	P09790	1	
5	Washer, 5/16" SAE Flat	F05011-17	2	
6	Nut, 5/16-18 Hex Nylon Lock	F05010-58	2	
7	Bolt, 3/8-16 X 4" Hex Head Grade 2	F05007-4	2	
8	Washer, 3/8" SAE Flat	F05011-3	2	
9	Washer, 3/8" External Star	F05011-36	2	
10	Nut, 3/8" Hex Nylon Lock	F05010-10	2	
11	Washer, 1/4" SAE Flat	F05011-11	2	
12	Nut, 1/4-20 Wing	F05010-13	2	
13	Box Weldment, Battery	015472	1	

5 Control & Battery Boxes

Battery Box Assembly

14	Fuse Box Parts (See Section 5.10)			
	Hydraulic Positive Contact Assembly Parts (See Section 10.6)			
15	Grommet, 5/8" Rubber Wire	P11764	5	
16	LID WELDMENT, BATTERY BOX STANDARD	015774 ²	1	
17	DECAL, BATTERY BOX LID CAUTION	014774	1	
18	CABLE ASSEMBLY, 1 GA X 12" 150A FUSE TO BATTERY POSITIVE	036308	1	
19	CABLE ASSEMBLY, 1 GA X 16" 225A FUSE TO BATTERY POSITIVE	036309	1	
20	CABLE ASSEMBLY, 1 GA X 26" BATTERY NEGATIVE TO NEG. CONTACT	036306 ³	1	

¹ Battery Box Assembly 015471 modified to include new fuse block and mega fuses 1/09 ([See Section 5.10](#)).

² Replaces S10447 (LT30HD/40HD rev. G3.00).

³ Replaces 024676 originally supplied (duplicate parts).

5.10 Fuse Box Assembly

LT30HD
LT40HD

Rev. J5.00 - J7.00
Rev. J6.00 - J8.00

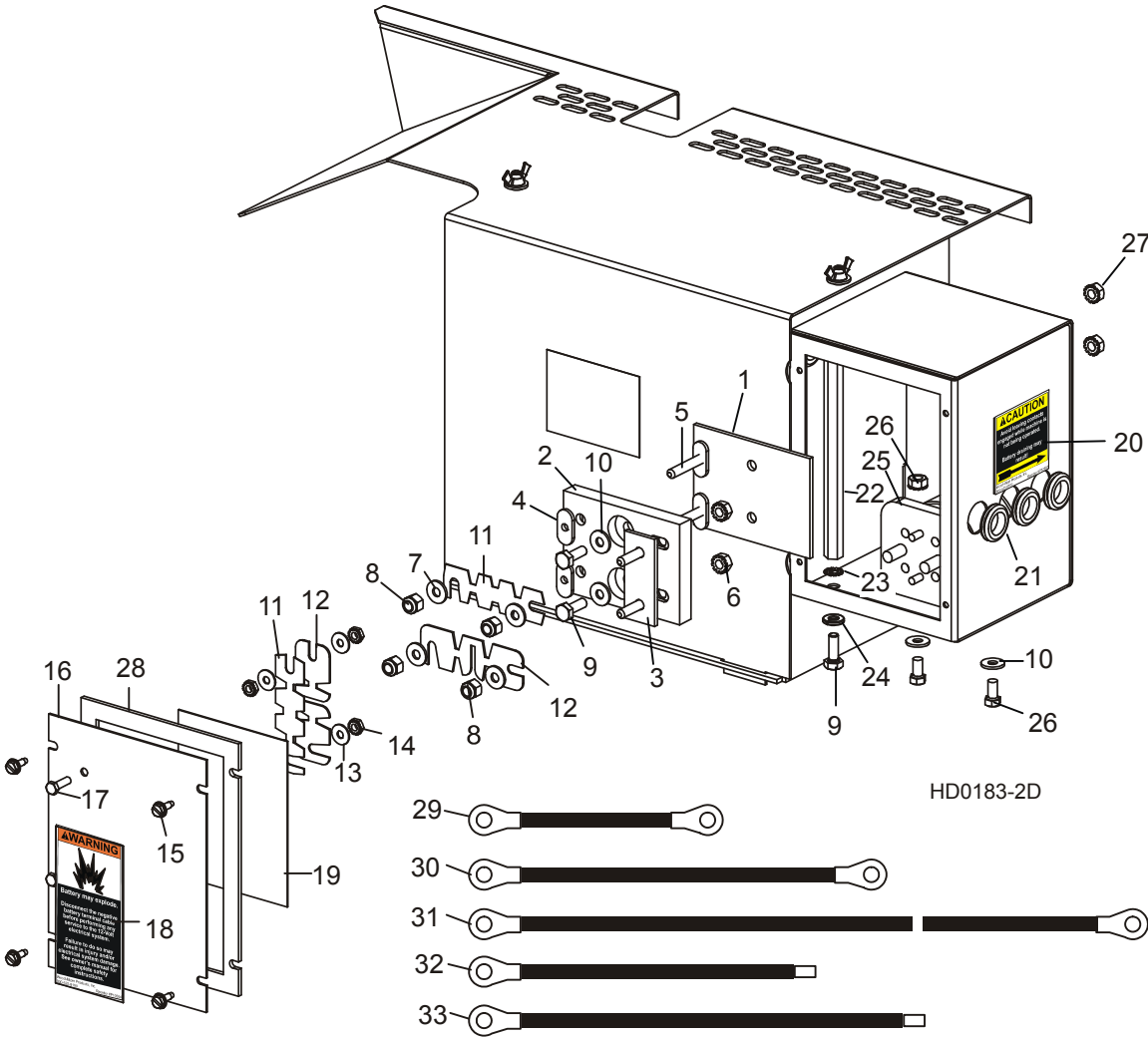

REF	DESCRIPTION (◆ Indicates Parts Available In Assemblies Only)	PART #	QTY.	
1	PAD, FUSE BOX INSULATOR	015287	1	
	FUSE BLOCK ASSEMBLY	017665 ¹	1	
2	Block, Fuse Mount	017664	1	◆
3	Post Weldment, Fuse Mount	017663	1	
4	Nut, 1/4-20 Cadmium Plated Weld	S12392	2	
5	Stud Weldment, 1/4-20 Fuse	W12389	2	
6	Nut, 1/4-20 Self-Locking Hex	F05010-9	2	
7	Washer, 1/4" SAE Flat	F05011-11	4	

5 Control & Battery Boxes

Fuse Box Assembly

8	Nut, 1/4-20 Hex Lock	F05010-21 ²	4	
9	BOLT, 1/4-20 X 3/4" HEX HEAD FULL THREAD	F05005-1	3	
10	WASHER, 1/4" SAE FLAT	F05011-11	4	
11	FUSE LINK, 12 VOLT 150 AMP	023361	2	
12	FUSE LINK, 12 VOLT 225 AMP	P11550	2	
13	WASHER, #10 SAE FLAT	F05011-18	4	
14	NUT, #10-24 HEX SELF-LOCKING	F05010-14	4	
15	SCREW, #10-24 X 1/2" SELF-TAPPING	F05015-7	4	
16	COVER, FUSE BOX	015282	1	
17	SCREW, #10-24 X 5/8" HEX HEAD	F05004-18	2	
18	DECAL, 12 VOLT WARNING	P10364	1	
19	DECAL, FUSE LINK 150/225A I.D.	015371	1	
20	DECAL, HYDRAULIC CONTACT CAUTION	P12960	1	
21	GROMMET, 5/8" RUBBER WIRE	P11764	3	
22	TERMINAL, EXTENDED HEX STUD	015517	1	
23	WASHER, 1/4" EXTERIOR STAR	F05011-37	1	
24	WASHER, 1/4" SPLIT LOCK	F05011-14	1	
25	SOLENOID, 200A 12V SPST CONT. DUTY	016371	1	
	Solenoid, 200A 12V SPST Cont. Duty	015470	1	◆
	Diode Assembly, Solenoid Coil Chassis Gnd	015426 ³	1	
	WIRE ASSEMBLY, HYDRAULIC SOLENOID VOLTAGE DROP	024451	1	
26	BOLT, 1/4-20 X 1/2" HEX HEAD	F05005-15	2	
27	NUT, 1/4-20 SELF-LOCKING HEX	F05010-9	4	
28	GASKET, FUSE BOX COVER	050283	1	
29	CABLE ASSEMBLY, 1 GA X 6 1/2" FUSE TO SOLENOID	036305	1	
30	CABLE ASSEMBLY, 1 GA X 14" SOLENOID TO POSITIVE CONTACT	036307	1	
31	CABLE ASSEMBLY, 1 GA X 26" BATT. NEGATIVE TO GROUND CONTACT	036306	1	
32	CABLE ASSEMBLY, 1 GA X 12" 150A FUSE TO BATTERY POSITIVE	036308	1	
33	CABLE ASSEMBLY, 1 GA X 16" 225A FUSE TO BATTERY POSITIVE	036309	1	

¹ Battery Box Assembly modified to include new fuse block and mega fuse 1/09. Use kit 006906 to retrofit (requires two 150A Mega-Fuse 052370-150 and two 225A Mega-Fuse 053339 sold separately).

² Swaged lock nut F05010-21 replaces Nylon Lock Nut F05010-69 originally supplied prior to 7/08. Heat from the fuses can cause the nylon to melt and the nut to come loose. Nuts and washers added to fuse block kit 017665 11/08.

³ Diode Assembly 015426 added to prevent damage to hydraulic microswitch (8/04).

5.11 Fuse Box Assembly

LT30HD
LT40HD

Rev. G1.00 - J4.00
Rev. G1.00 - J5.00

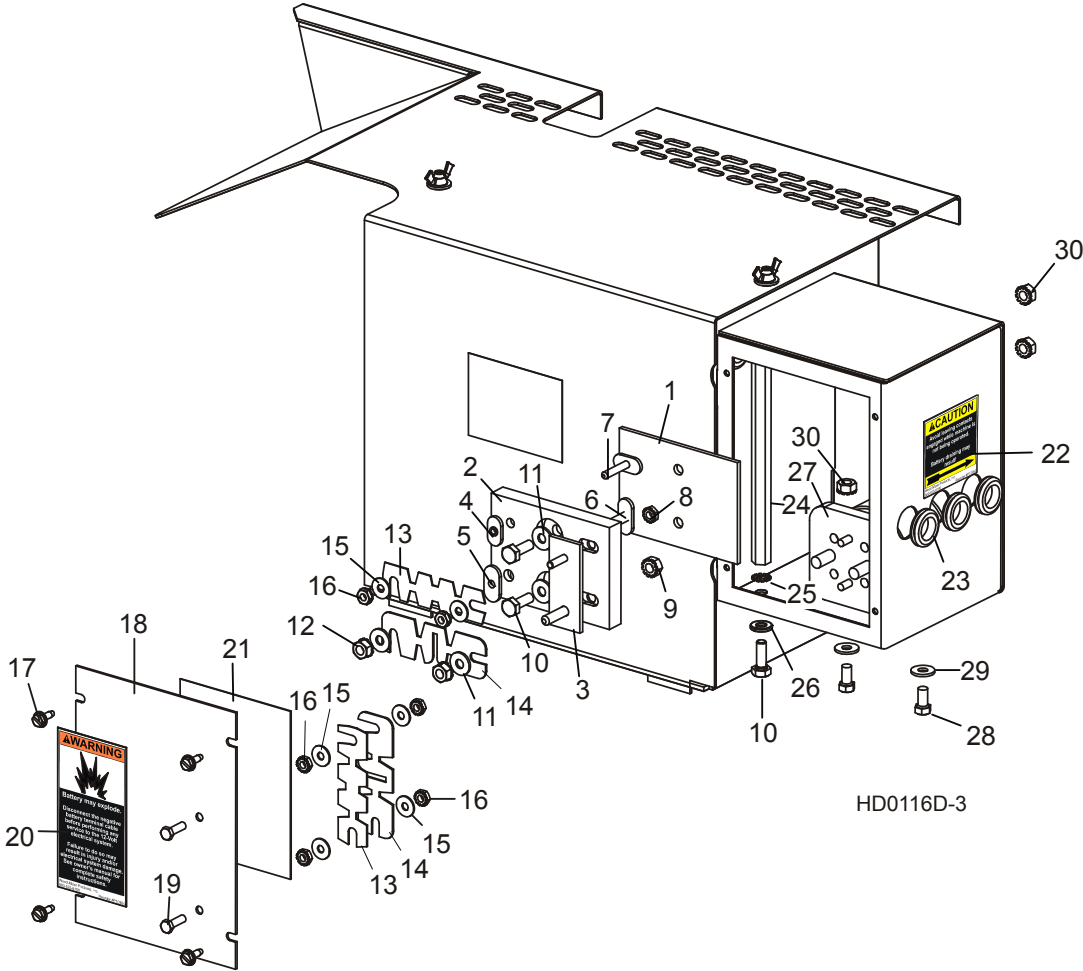

REF	DESCRIPTION (◆ Indicates Parts Available In Assemblies Only)	PART #	QTY.	
1	PAD, FUSE BOX INSULATOR	015287	1	
	FUSE BLOCK ASSEMBLY	015288 ¹	1	◆
2	Block, Fuse Mount	015286	1	◆
3	Buss Weldment, Fuse Mount	015289	1	
4	Nut, #10-24 Cadmium Plated Weld	S12391	1	
5	Nut, 1/4-20 Cadmium Plated Weld	S12392	1	
6	Stud Weldment, 1/4-20 Fuse	W12389	1	
7	Stud Weldment, #10-24 Fuse	W12390	1	

5 Control & Battery Boxes

Fuse Box Assembly

8	Nut, #10-24 Self-Locking Hex	F05010-14	1	
9	Nut, 1/4-20 Self-Locking Hex	F05010-9	1	
10	BOLT, 1/4-20 X 3/4" HEX HEAD FULL THREAD	F05005-1	3	
11	WASHER, 1/4" SAE FLAT	F05011-11	4	
12	NUT, 1/4-20 HEX LOCK	F05010-21 ²	2	
13	FUSE LINK, 12 VOLT 150 AMP	023361	2	
14	FUSE LINK, 12 VOLT 225 AMP	P11550	2	
15	WASHER, #10 SAE FLAT	F05011-18 ³	6	
16	NUT, #10-24 HEX SELF-LOCKING	F05010-14 ³	6	
17	SCREW, #10-24 X 1/2" SELF-TAPPING	F05015-7	4	
18	COVER, FUSE BOX	015282 ³	1	
19	SCREW, #10-24 X 5/8" HEX HEAD	F05004-18 ³	2	
20	DECAL, 12 VOLT WARNING	P10364	1	
21	DECAL, FUSE LINK 150/225A I.D.	015371	1	
22	DECAL, HYDRAULIC CONTACT CAUTION	P12960	1	
23	GROMMET, 5/8" RUBBER WIRE	P11764	3	
24	TERMINAL, EXTENDED HEX STUD	015517 ⁴	1	
25	WASHER, 1/4" EXTERIOR STAR	F05011-37	1	
26	WASHER, 1/4" SPLIT LOCK	F05011-14	1	
27	SOLENOID, 200A 12V SPST CONT. DUTY	016371 ⁵	1	
	Solenoid, 200A 12V SPST Cont. Duty	015470	1	◆
	Diode Assembly, Solenoid Coil Chassis Gnd	015426 ⁶	1	
	WIRE ASSEMBLY, HYDRAULIC SOLENOID VOLTAGE DROP	024451 ⁷	1	
28	BOLT, 1/4-20 X 1/2" HEX HEAD	F05005-15	2	
29	WASHER, 1/4" SAE FLAT	F05011-11	2	
30	NUT, 1/4-20 SELF-LOCKING HEX	F05010-9	4	

¹ Replace Fuse Block Assembly 015288 with Mega-Fuse Block Assembly 006906 (replaces High-Amp Fuse Block Retro 017665). New fuse block requires one 150A Mega-Fuse 052370-150 and one 225A Mega-Fuse 053339 sold separately. New fuse block kit includes replacement ring terminals for 150A fuse (F05092-18R).

² Swaged lock nut F05010-21 replaces Nylon Lock Nut F05010-69 originally supplied prior to 7/08. Heat from the fuses can cause the nylon to melt and the nut to come loose.

³ 015282 Fuse Box Cover revised with additional hole to accept second set of hardware to secure spare fuses (1/00). Additional (1) F05004-18 #10-24 x 5/8" Hex Head Screw, (2) F05011-18 #10 SAE Flat Washers and (2) F05010-16 #10-24 Self-Locking Nuts added to assembly.

⁴ Terminal Extension Stud added 3/97.

⁵ Solenoid and Voltage Drop Wire Assembly added LT30HD and LT40HD Rev. G7.00. Solenoid Kit 016371 replaces Solenoid 015470. Kit includes solenoid and replacement instructions.

⁶ Diode Assembly 015426 added to prevent damage to hydraulic microswitch (8/04).

⁷ Solenoid and Voltage Drop Wire Assembly added LT30HD and LT40HD Rev. G7.00.

SECTION 6 UP/DOWN SYSTEM

6.1 Saw Head Mount

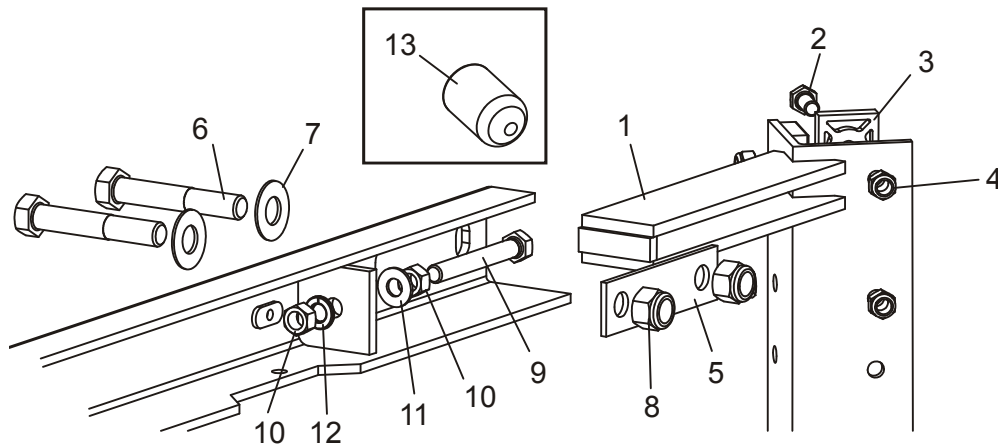

SM0080D

REF	DESCRIPTION (◆ Indicates Parts Available In Assemblies Only)	PART #	QTY.
1	V-BRACE, SAW HEAD MOUNT	W04099	1
2	BOLT, 5/16-18 X 3/4" HEX HEAD GRADE 5	F05006-5	12
	BOLT, 5/16-18 X 1 1/4" HEX HEAD FULL THREAD	F05006-1 ¹	2
	BOLT, 5/16-18 X 1 1/4" HEX HEAD FULL THREAD GRADE 5	F05006-93	4
3	PAD, PLASTIC SLIDE	M04096 ²	6
	PAD, PLASTIC SLIDE LOWER W/CHAMFER	016241	2
4	NUT, 5/16-18 NYLON LOCK	F05010-58	16
5	PLATE, V-BRACE WASHER	S07935	2
6	BOLT, 1/2-13 X 3 1/2" HEX HEAD GRADE 5	F05008-61	4
7	WASHER, 1/2" SAE FLAT	F05011-2	4
8	NUT, 1/2-13 NYLON LOCK	F05010-8	4
9	BOLT, 3/8-16 X 2" FULL THREAD	F05007-17 ³	2
10	NUT, 3/8-16 HEX	F05010-1	4
11	WASHER, 3/8" SAE FLAT	F05011-3	2
12	WASHER, 3/8" SPLIT LOCK	F05011-4	2
13	CAP, .281" X 1/2" BLACK VINYL	017715 ⁴	3

¹ Longer bolts used to mount G24 engine throttle cable prior to 11/97.

² Eight pads removed from middle positions (Rev. H2.00). Only uppermost and lowermost pads are required. Middle pads were not providing any function.

³ 2" Bolt F05007-17 replaces 3" Bolt F05007-1 originally supplied prior to LT30HD/LT40HD Rev. H4.00.

6 Up/Down System *Saw Head Mount*

⁴ Vinyl caps added to protect drive-side blade housing cover when being removed/replaced (LT30HD Rev. J4.00 and LT40HD Rev. J5.00).

6.2 Blade Height & Quarter Scales

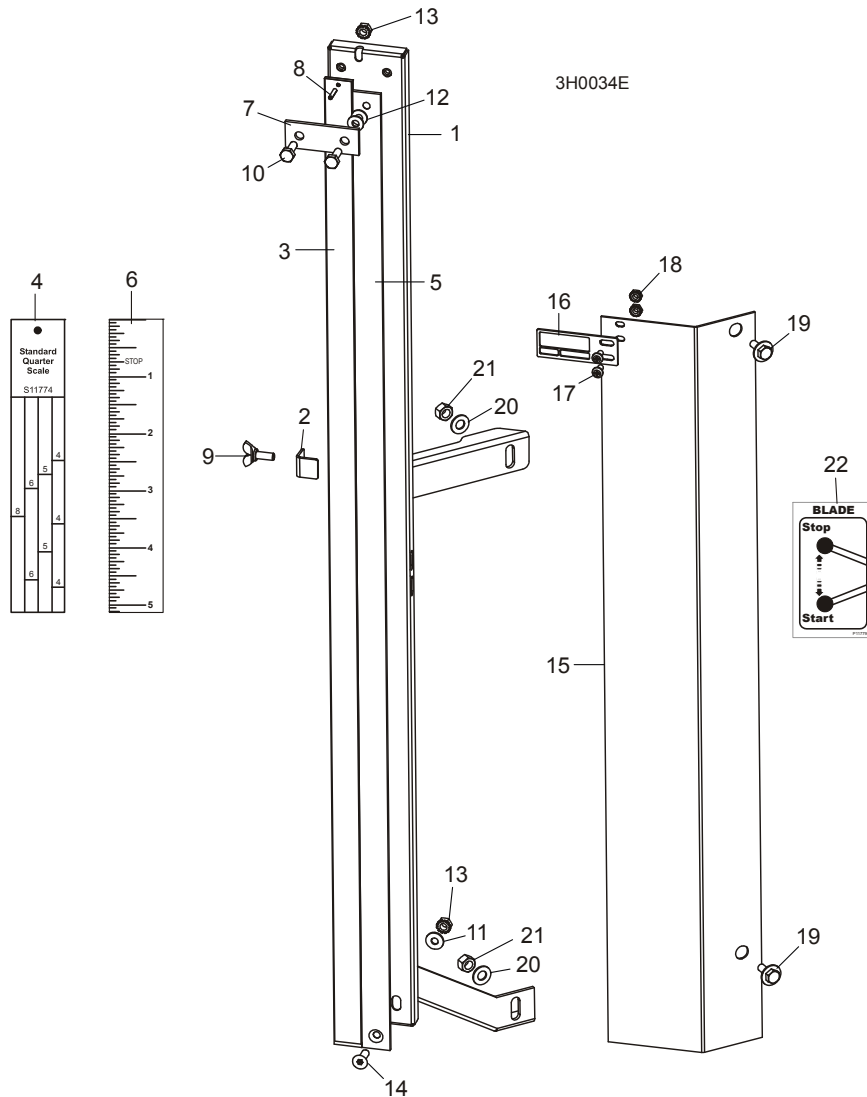

REF	DESCRIPTION (◆ Indicates Parts Available In Assemblies Only)	PART #	QTY.	
	SCALE RETROFIT, FIXED WITH POINTER	A12030	1	
	Scale Kit, Fixed With Pointer	K11998	1	◆
	Scale Assembly, Fixed	A12022	1	◆
1	Bracket, Scale Mounting	W11996 ¹	1	
2	Plate, Movable Scale Stop	036666 ¹	1	
3	Scale, 35" Quarter	S11989	1	
4	Decal, 35" Standard Quarter Scale	S11774	1	
	Decal, 35" Grade Hardwood Quarter Scale	P12819	1	
5	Scale, 35" Inch	S11988	1	

6

Up/Down System

Blade Height & Quarter Scales

6	Decal, 35" Inch	S11773	1	
7	Strap, Scale Hold-Down	S04805	1	
8	Pin, 1/8" X 5/8" Roll	F05012-14	1	
9	Screw, 1/4-20 X 5/8" Wing	F05005-64	1	
10	Bolt, 1/4-20 x 1/2" Hex Head	F05005-1	2	
11	Washer, 1/4" SAE Flat	F05011-11	1	
12	Washer, 1/4" X .020 Thick Nylon Flat	F05011-22	2	
13	Nut, 1/4-20 Hex Self-Locking	F05010-9	2	
14	Screw, 1/4-20 X 3/4" Flat Socket Head	F05005-70	1	
	Pointer Assembly, Fixed Scale	A12023 ²	1	
15	Bracket, Fixed Scale Pointer Mount	S12245	1	◆
16	Pointer, Fixed Scale (Non-Accuset Only ³)	017778	1	
17	Screw, #10-24 X 3/8" Phillips Head	F05004-3	2	
18	Nut, #10-24 Hex Self-Locking	F05010-14	2	
19	Bolt, 1/4-20 x 3/4" with Conical Washer	F05005-134 ⁴	2	
20	Washer, 5/16" SAE Flat	F05011-17	2	
21	Nut, 5/16-18 Hex Lock	F05010-6	2	
	Bolt, 1/4-20 X 1/2" Hex Head Grade 2	F05005-15	1	
	Instruction Sheet, Fixed Scale Retrofit	A12030-370	1	
	DECAL KIT, METRIC SCALE	K12064	1	
	Decal, Metric	S11711	1	
	Decal, Metric 16-40mm	P12040-1	1	
	Decal, Metric 45-63mm	P12040-2	1	
22	DECAL, CLUTCH HANDLE OPERATION	P11779	1	

¹ Wing screw moved to side of scale mount and bracket 036666 added to eliminate possible interference with pointer (11/04). Use W11996 to service mount weldment (includes new bracket 036666).

² Scale Assembly A12023 modified with steel pointer (LT30HD Rev. J5.00 and LT40HD Rev. J6.00). 017778 replaces M07267-N pointer.

³ Use 017805 pointer for sawmills equipped with Accuset control (Steel pointer replaces 035447).

⁴ Replaces 1/4" SAE Flat Washer (F05011-11) and 1/4-20 X 3/4" Full Thread Hex Head Cap Bolt (F05005-1) LT30HD/40HD rev. H1.00.

6.3 Up/Down Chain & Sprockets

LT30HD
LT40HD

Rev. G7.01 - J7.00
Rev. G7.01 - J8.00

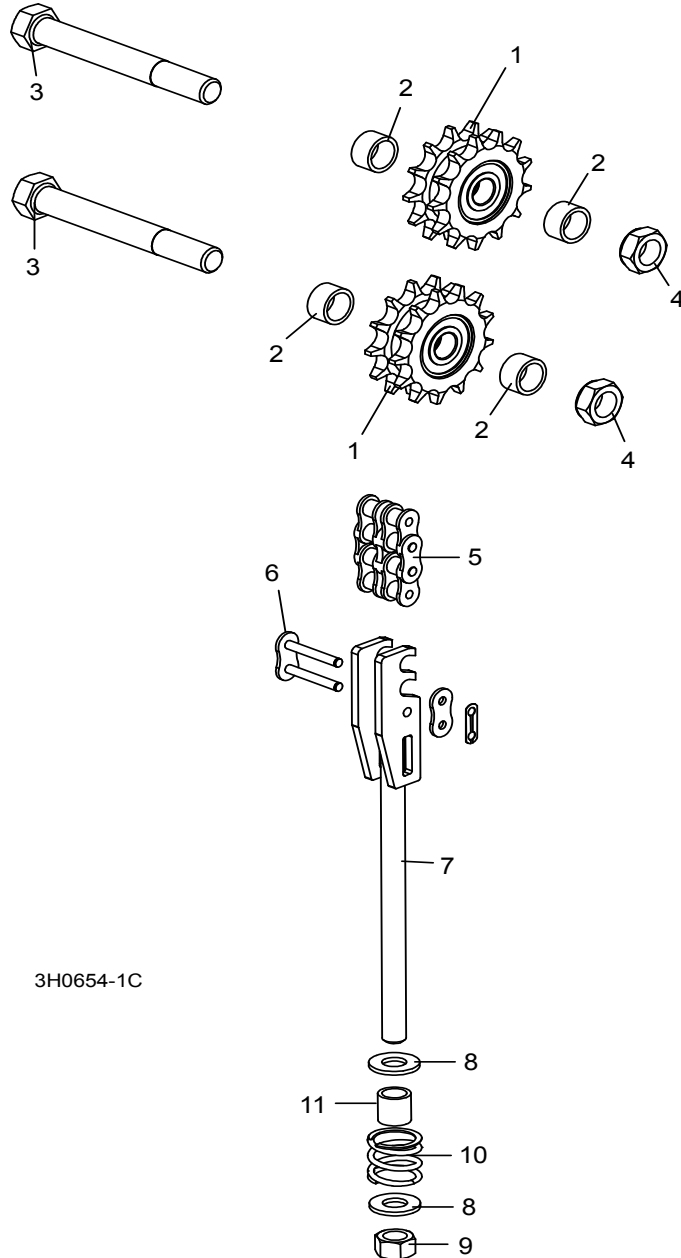

REF	DESCRIPTION (◆ Indicates Parts Available In Assemblies Only)	PART #	QTY.
	SPROCKET KIT, UP/DOWN IDLER #50-2	016020	1
1	Sprocket, Up/Down Idler '98	016019	2
2	Spacer, 50-2 Idler '98	016018	4

6

Up/Down System*Up/Down Chain & Sprockets*

	Instruction Sheet, Up/Down Idler Retrofit	016020-541	1	
3	BOLT, 5/8-11 X 5" HEX HEAD GRADE 2	F05009-6	2	
4	NUT, 5/8-11 JAM NYLON LOCK	F05010-96 ¹	2	
5	CHAIN, #50-2 X 75.625" UP/DOWN	015259	1	
6	LINK, #50-2 MASTER	015258	2	
	TENSIONER ASSEMBLY, UP/DOWN CHAIN	015456 ²	1	
7	Bracket, Up/Down #50 Chain Tensioner	015188	1	◆
8	Washer, 1/2" SAE Flat	F05011-2	2	
9	Nut, 1/2-13 Nylon Hex Lock	F05010-8	1	
10	Spring, 1" OD x 1" Long x .125" Wire Compression	016516	1	
11	Spacer, Up/Dn Chain Tensioner	016515	1	

¹ Replaces 5/8-11 Hex Nylon Lock Nut (F05010-34) LT30HD/40HD rev. H1.00.

² Spring, spacer and hardware replaces original split lock washers and jam nuts supplied prior to LT30HD/40HD Rev. H7.00. New assembly requires less frequent adjustment and prevents damage to the up/down system. [See Section 6.4](#) for hardware used on previous revisions.

6.4 Up/Down Chain & Sprockets

LT30HD
LT40HD

Rev. G6.00 - G7.00
Rev. G6.00 - G7.00

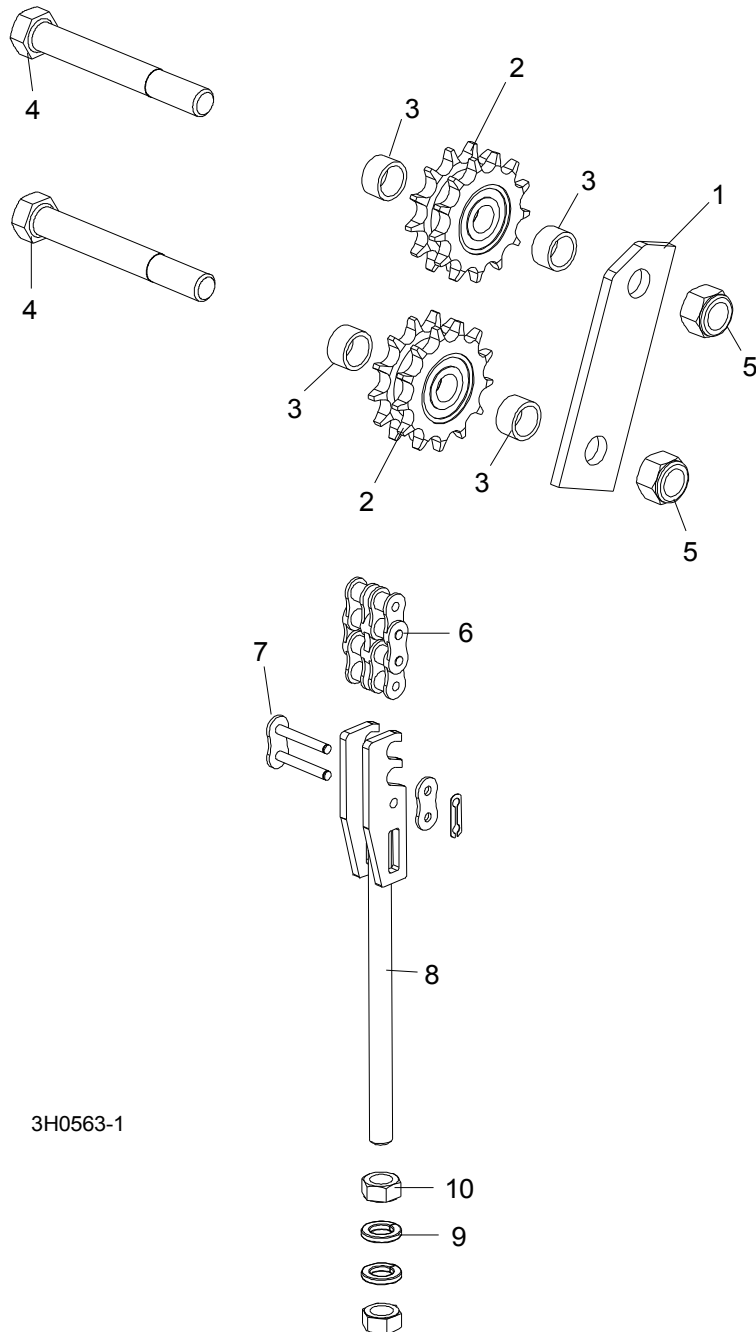

3H0563-1

REF	DESCRIPTION (◆ Indicates Parts Available In Assemblies Only)	PART #	QTY.
1	PLATE, UP/DOWN IDLER SPROCKET	S09084	1

6

Up/Down System*Up/Down Chain & Sprockets*

	SPROCKET KIT, UP/DOWN IDLER #50-2	016020 ¹	1	
2	Sprocket, Up/Down Idler '98	016019	2	
3	Spacer, 50-2 Idler '98	016018	4	
	Instruction Sheet, Up/Down Idler Retrofit	016020-541	1	
4	BOLT, 5/8-11 X 5" HEX HEAD GRADE 2	F05009-6	2	
5	NUT, 5/8-11 JAM NYLON LOCK	F05010-96 ²	2	
6	CHAIN, #50-2 X 75.625" UP/DOWN	015259	1	
7	LINK, #50-2 MASTER	015258	2	
	TENSIONER ASSEMBLY, UP/DOWN CHAIN	015456 ³	1	
8	Bracket, Up/Down #50 Chain Tensioner	015188	1	◆
9	Washer, 1/2" Split Lock	F05011-9	2	
10	Nut, 1/2-13 Hex	F05010-35	2	

¹ Use sprocket kit to retrofit previous revision sawmills. New design sprockets and spacers eliminate preloading of the bearings.

² Replaces 5/8-11 Hex Nylon Lock Nut (F05010-34) LT30HD/40HD rev. H1.00.

³ Assembly includes new spring and hardware ([See Section 6.3](#)). New assembly requires less frequent adjustment and prevents damage to the up/down system.

6.5 Up/Down Chain & Sprockets

LT30HD
LT40HD

Rev. G1.00 - G5.02
Rev. G1.00 - G5.02

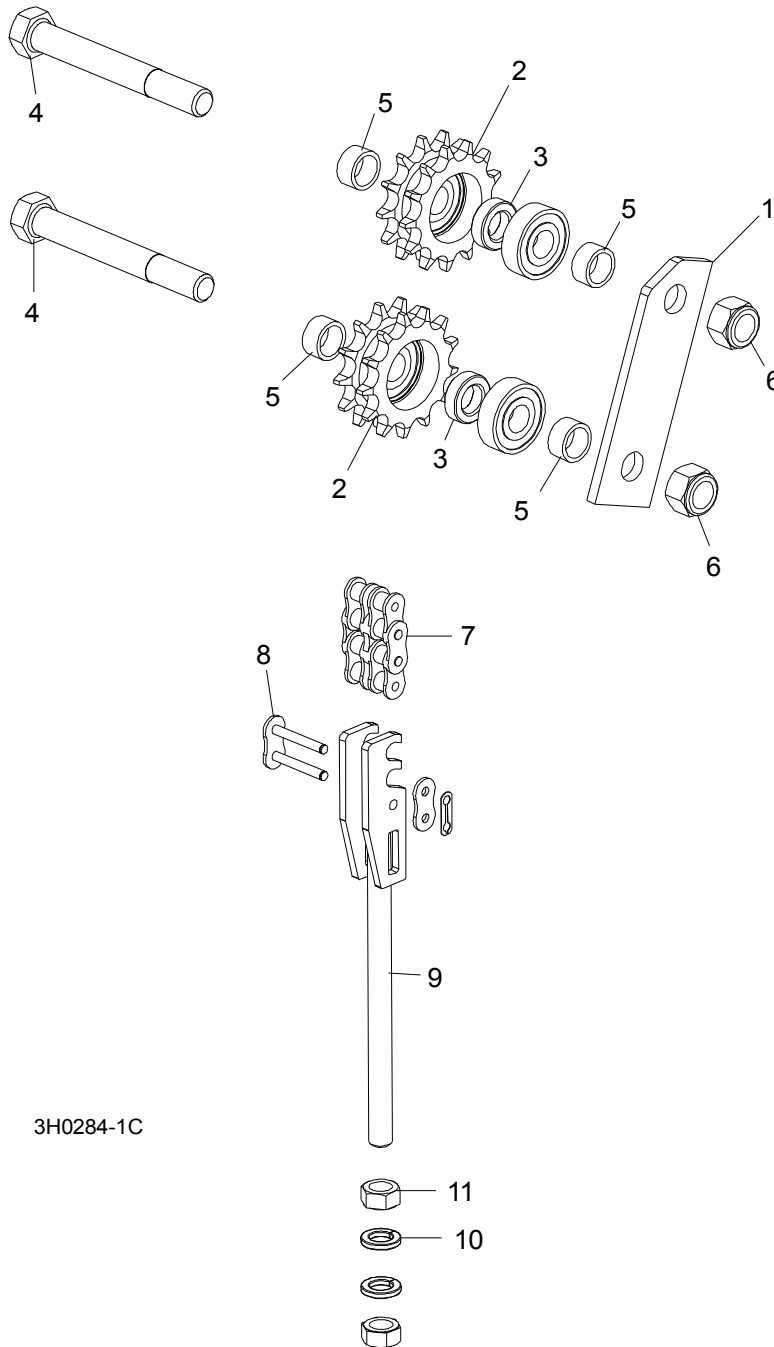

REF	DESCRIPTION	PART #	QTY.
	(◆ Indicates Parts Available In Assemblies Only)		

6

Up/Down System

Up/Down Chain & Sprockets

1	PLATE, UP/DOWN IDLER SPROCKET	S09084	1	
2	SPROCKET ASSEMBLY W/BEARING, UP/DOWN IDLER #50 CHAIN	015455 ¹	2	◆
3	SPACER, 1.09" O.D. X .63" I.D. X .35" LONG	015965 ¹	2	◆
4	BOLT, 5/8-11 X 5" HEX HEAD GRADE 2	F05009-6	2	
5	SPACER, 50-2 IDLER SPROCKET	014724 ¹	4	◆
6	NUT, 5/8-11 JAM NYLON LOCK	F05010-96 ²	2	
7	CHAIN, #50-2 X 75.625" UP/DOWN	015259	1	
8	LINK, #50-2 MASTER	015258	2	
	TENSIONER ASSEMBLY, UP/DOWN CHAIN	015456 ³	1	
9	Bracket, Up/Down #50 Chain Tensioner	015188	1	◆
10	Washer, 1/2" Split Lock	F05011-9	2	
11	Nut, 1/2-13 Hex	F05010-35	2	

¹ Use kit 016020 to replace all idler sprockets and spacers ([See Section 6.3](#)). Sprocket kit replaces 015455 or 015202 sprockets, 015965 interior spacers, P06030-1 bearings and 014724 exterior spacers originally supplied on previous revisions. New design sprockets and spacers eliminate preloading of the bearings.

² Replaces 5/8-11 Hex Nylon Lock Nut (F05010-34) LT30HD/40HD rev. H1.00.

³ Assembly includes new spring and hardware ([See Section 6.3](#)). New assembly requires less frequent adjustment and prevents damage to the up/down system.

6.6 Up/Down Assembly, G24/G25

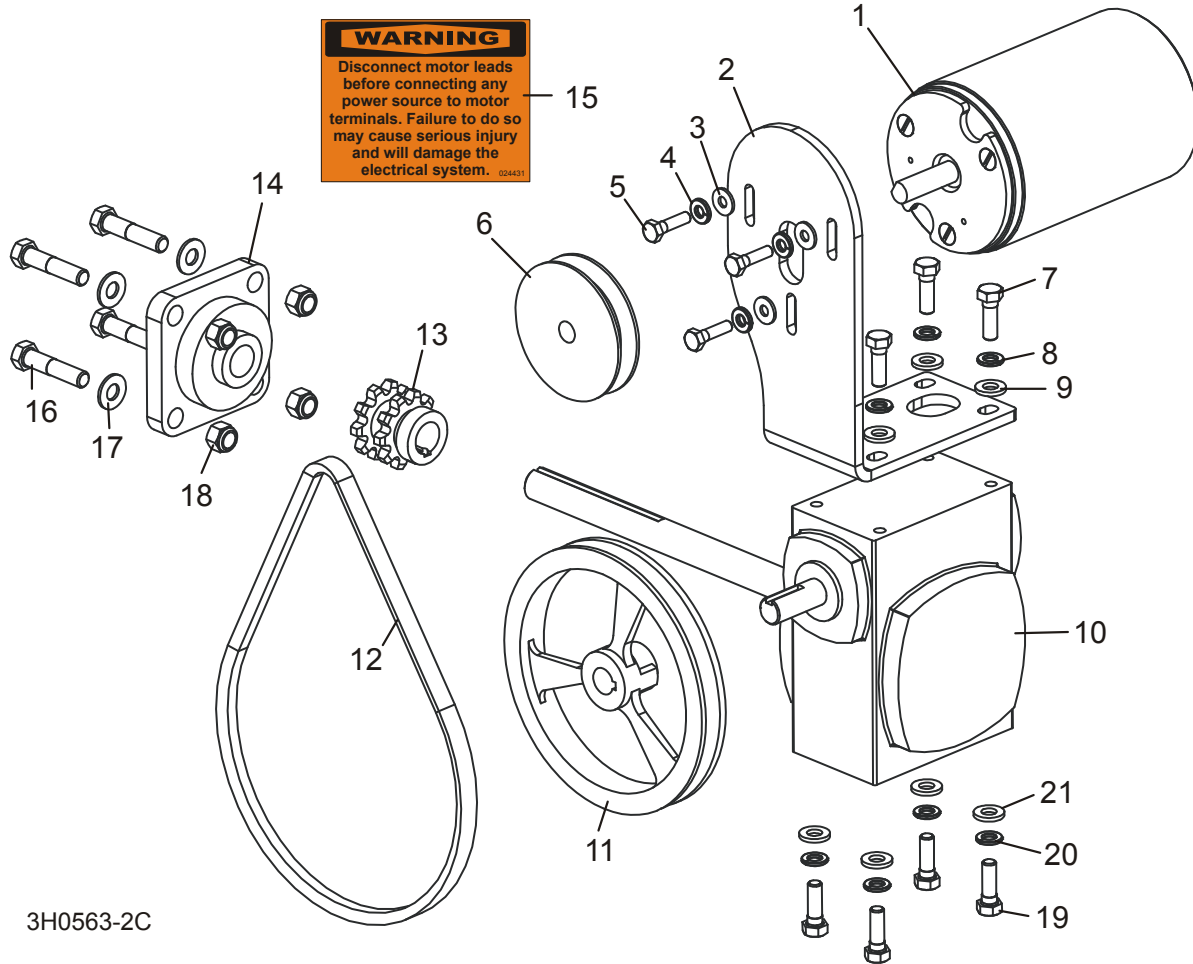

REF	DESCRIPTION (◆ Indicates Parts Available In Assemblies Only)	PART #	QTY.	
	UP/DOWN DRIVE ASSEMBLY (G24/G25)	014669 ¹	1	◆
1	Motor, Drive	006747 ²	1	
	Brush Kit, 12V Motor (2009)	061794 ²	1	
	Brush Kit, 12V Motor (2007)	006619 ²	1	
	Brush Kit, 12V Motor	A09086 ²	1	
	Brush Holder, Motor	034000 ²	1	◆
2	Bracket, Up/Down Motor Mount	014529	1	
3	Washer, 1/4" SAE Flat	F05011-11	3	
4	Washer, 1/4" Split Lock	F05011-14	3	
5	Bolt, 1/4-20 X 1" Hex Head Grade 2	F05005-38	3	
6	Pulley, AK 32Up/Down Motor	014087	1	
7	Bolt, 5/16-18 x 1" Hex Head	F05006-1	4	

6

Up/Down System

Up/Down Assembly, G24/G25

8	Washer, 5/16" Split Lock	F05011-13	4	
9	Washer, 5/16" SAE Flat	F05011-17	4	
10	Reducer, Gear Box	016622 ¹	1	◆
11	Pulley, Up/Down	014528	1	
12	Belt, 4L280	P04031	1	
13	Sprocket, Up/Down Dual #50 Chain	015346	1	
14	Bearing, Flanged Up/Down	P11600	1	
15	Decal, Disconnect Motor Leads Warning	024431	1	
16	BOLT, 3/8-16 X 1 1/2" HEX HEAD	F05007-3	4	
17	WASHER, 3/8" SAE FLAT	F05011-3	4	
18	NUT, 3/8-16 HEX NYLON LOCK	F05010-10	4	
19	BOLT, 5/16-18 X 3/4" HEX HEAD	F05006-5	4	
20	WASHER, 5/16" SPLIT LOCK	F05011-13	4	
21	WASHER, 5/16" SAE FLAT	F05011-17	4	
	OIL, 8 OZ. MOBIL SHC634 BOTTLED SYNTHETIC GEAR	L04869-4 ³	1	

¹ 014669 assembly with 016622 gearbox replaced with heavy-duty system due to availability from vendor ([See Section 6.7](#)). Use kit 038560 to retrofit gearbox originally supplied. Kit includes gearbox, pulleys, belt and mounting hardware. 016622 replaced P11692 gear box supplied prior to Rev. J2.01. New gear box features alloy shaft to provide better durability.

² Motor 006747 replaces Motor 014359 supplied until 11/08. Order brush kit Part No. A09086 for sawmills built prior to 7/2007 equipped with motors that do not have red and black terminals and are not labeled "Current Applications". Order brush kit Part No. 006619 for sawmills built between 8/2007 and 11/2008 with motors equipped with red and black terminals and not labeled "Current Applications". Order brush kit Part No. 061794 for sawmills built after 11/2008 and/or equipped with motors labeled "Current Applications". Brush Holder 034000 applies only to original 014359 motor and is no longer available (vendor discontinued 3/09).

³ 8 - 11 oz. required for complete oil replacement.

6.7 Up/Down Assembly, D33/G36

LT30HD
LT40HD

Rev. J6.00 - J7.00
Rev. J7.00 - J8.00

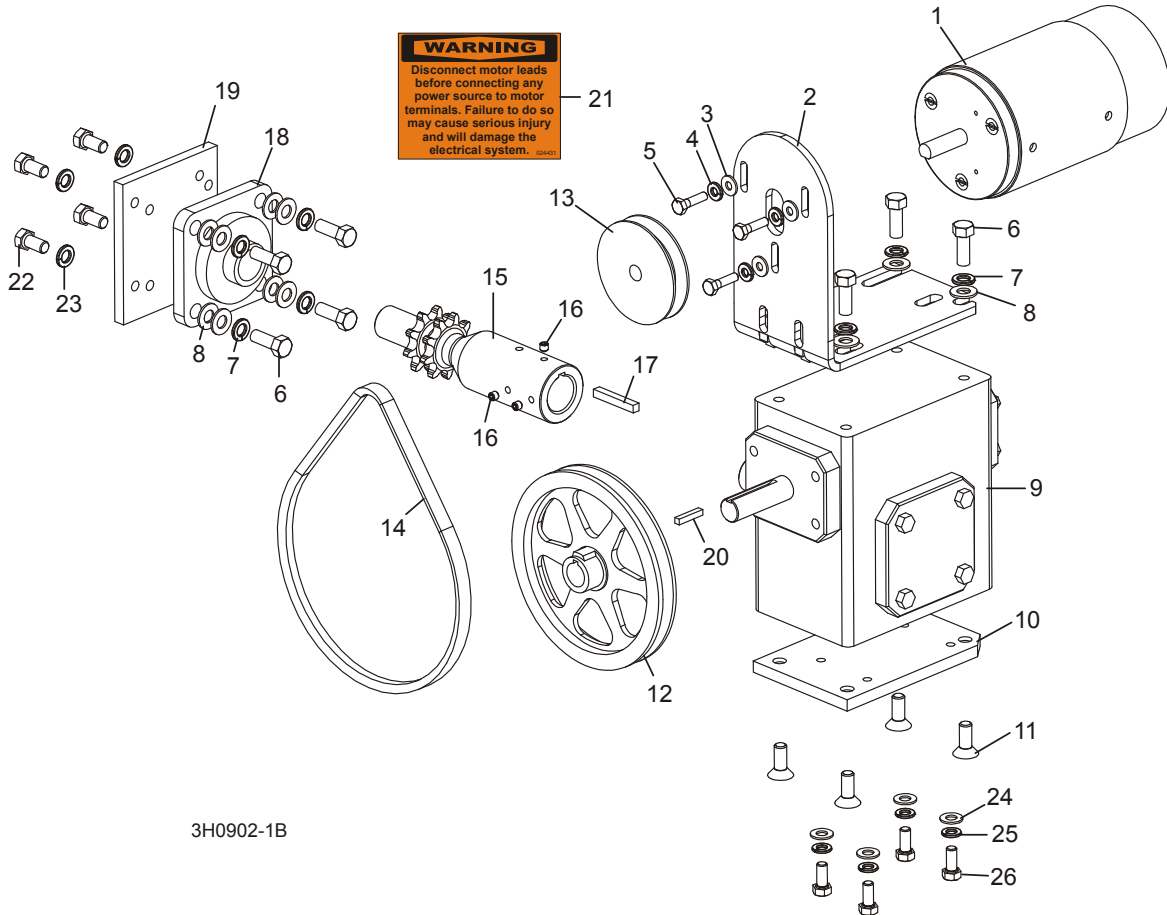

3H0902-1B

REF	DESCRIPTION (◆ Indicates Parts Available In Assemblies Only)	PART #	QTY.	
	UP/DOWN DRIVE ASSEMBLY (D33/G36)	036208	1	
1	Motor, Drive	006747 ¹	1	
	Brush Kit, 12V Motor (2009)	061794 ¹	1	
	Brush Kit, 12V Motor (2007)	006619 ¹	1	
	Brush Kit, 12V Motor	A09086 ¹	1	
	Brush Holder, Motor	034000 ¹	1	◆
2	Bracket, Up/Down Motor Mount	014073	1	
3	Washer, 1/4" SAE Flat	F05011-11	3	
4	Washer, 1/4" Split Lock	F05011-14	3	
5	Bolt, 1/4-20 X 1" Hex Head Grade 5	F05005-101	3	

6

Up/Down System

Up/Down Assembly, D33/G36

6	Bolt, 3/8-16 x 1" Hex Head	F05007-7	8	
7	Washer, 3/8" Split Lock	F05011-4	8	
8	Washer, 3/8" SAE Flat	F05011-3	12	
9	Reducer, Gear Box	014074	1	
10	Plate, Gear Box Spacer	014158	1	
11	Bolt, 3/8-16 x 1" Flat Socket Head	F05007-64	4	
12	Pulley, Up/Down	014088	1	
	Belt/Pulley Kit, Standard D33/G36 Up/Down	036213	1	
13	Pulley, AK22 x 1/2"	036204	1	
14	Belt, 4L270	014089	1	
	Shaft Kit, Up/Down Drive	016094	1	
15	Shaft, Up/Down Sprocket	016031	1	◆
16	Screw, 1/4-28 x 1/4" Socket Head Cup Point	F05005-105 ²	3	
17	Key, 1/4" Square x 1 11/16" Long	S04124	1	
18	Bearing, Flanged Up/Down	014090	1	
19	Plate, Bearing Spacer	014108	1	
20	Key, 3/16" Square x 1" Long	S31027	1	
21	Decal, Disconnect Motor Leads Warning	024431	1	
22	BOLT, 3/8-16 X 3/4" HEX HEAD	F05007-27	4	
23	WASHER, 3/8" SPLIT LOCK	F05011-4	4	
24	WASHER, 5/16" SAE FLAT	F05011-17	4	
25	WASHER, 5/16" SPLIT LOCK	F05011-13	4	
26	BOLT, 5/16-18 X 3/4" HEX HEAD GRADE 5	F05006-102	4	
	OIL, 8 OZ. MOBIL SHC634 BOTTLED SYNTHETIC GEAR	L04869-4 ³	1	

¹ Motor 006747 replaces Motor 014359 supplied until 11/08. Order brush kit Part No. A09086 for sawmills built prior to 7/2007 equipped with motors that do not have red and black terminals and are not labeled "Current Applications". Order brush kit Part No. 006619 for sawmills built between 8/2007 and 11/2008 with motors equipped with red and black terminals and not labeled "Current Applications". Order brush kit Part No. 061794 for sawmills built after 11/2008 and/or equipped with motors labeled "Current Applications". Brush Holder 034000 applies only to original 014359 motor and is no longer available (vendor discontinued 3/09).

² One F05005-105 replaces two F05004-76 #10-24 x 3/8" Cup Point Set Screws supplied prior to 7/07.

³ 24 oz. required for complete oil replacement.

6.8 Up/Down Assembly, D30/D33/G36

LT30HD
LT40HD

Rev. G1.00 - J5.07
Rev. G1.00 - J6.08

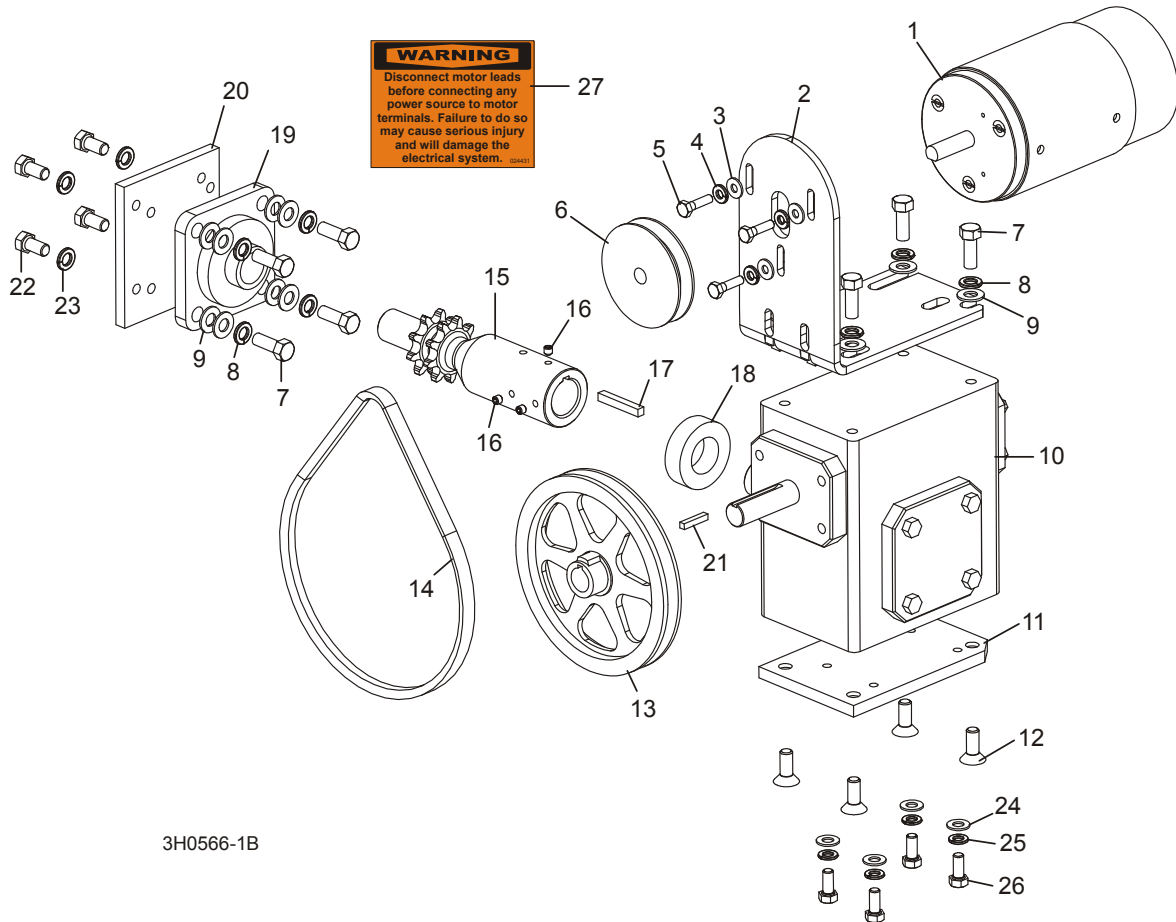

3H0566-1B

REF	DESCRIPTION (◆ Indicates Parts Available In Assemblies Only)	PART #	QTY.	
	UP/DOWN DRIVE ASSEMBLY (D30/D33/G36)	015458	1	
1	Motor, Drive	006747 ¹	1	
	Brush Kit, 12V Motor (2009)	061794 ¹	1	
	Brush Kit, 12V Motor (2007)	006619 ¹	1	
	Brush Kit, 12V Motor	A09086 ¹	1	
	Brush Holder, Motor	034000 ¹	1	◆
2	Bracket, Up/Down Motor Mount	014073	1	
3	Washer, 1/4" SAE Flat	F05011-11	3	
4	Washer, 1/4" Split Lock	F05011-14	3	
5	Bolt, 1/4-20 X 1" Hex Head Grade 2	F05005-38	3	

6

Up/Down System

Up/Down Assembly, D30/D33/G36

6	Pulley, AK32 Up/Down Motor	014087 ²	1	
7	Bolt, 3/8-16 x 1" Hex Head	F05007-7	8	
8	Washer, 3/8" Split Lock	F05011-4	8	
9	Washer, 3/8" SAE Flat	F05011-3	12	
10	Reducer, Gear Box	014074	1	
11	Plate, Gear Box Spacer	014158	1	
12	Bolt, 3/8-16 x 1" Flat Socket Head	F05007-64 ³	4	
13	Pulley, Up/Down	014088	1	
14	Belt, 4L280	P04031 ²	1	
	Shaft Kit, Up/Down Drive	016094 ⁴	1	
15	Shaft, Up/Down Sprocket	016031	1	◆
16	Screw, 1/4-28 x 1/4" Socket Head Cup Point	F05005-105 ⁵	3	
17	Key, 1/4" Square x 1 11/16" Long	S04124	1	
18	Spacer, Up/Down Shaft	016032 ⁶	1	
19	Bearing, Flanged Up/Down	014090	1	
20	Plate, Bearing Spacer	014108	1	
21	Key, 3/16" Square x 1" Long	S31027 ⁷	1	
22	BOLT, 3/8-16 X 3/4" HEX HEAD	F05007-27	4	
23	WASHER, 3/8" SPLIT LOCK	F05011-4	4	
24	WASHER, 5/16" SAE FLAT	F05011-17	4	
25	WASHER, 5/16" SPLIT LOCK	F05011-13	4	
26	BOLT, 5/16-18 X 3/4" HEX HEAD GRADE 5	F05006-102 ⁸	4	
	OIL, 8 OZ. MOBILE SHC634 BOTTLED SYNTHETIC GEAR	L04869-4 ⁹	1	
27	DECAL, DISCONNECT MOTOR LEADS WARNING	024431	1	

¹ Motor 006747 replaces Motor 014359 supplied until 11/08. Order brush kit Part No. A09086 for sawmills built prior to 7/2007 equipped with motors that do not have red and black terminals and are not labeled "Current Applications". Order brush kit Part No. 006619 for sawmills built between 8/2007 and 11/2008 with motors equipped with red and black terminals and not labeled "Current Applications". Order brush kit Part No. 061794 for sawmills built after 11/2008 and/or equipped with motors labeled "Current Applications". Brush Holder 034000 applies only to original 014359 motor and is no longer available (vendor discontinued 3/09).

² If sawmill equipped with Accuset option, use up/down pulley and belt supplied with kit 036213. Kit includes AK22 pulley 036204 and 4L270 belt 014089. An optional speed reduction kit is available to reduce the speed of the up/down system to enable the operator to more easily align blade height with the blade height scale. Kit (015919) includes AK25 pulley (015917) and 4L240 belt (015918) and instructions (015919-338). Available 10/97.

³ Replaces F05007-110 originally supplied to accommodate common parts.

⁴ Use shaft kit 016094 to replace two-piece shaft/coupler 015201 and 014159 and 3" key 014099 originally supplied prior to LT30HD and LT40HD Rev. G6.06.

⁵ One F05005-105 replaces two F05004-76 #10-24 x 3/8" Cup Point Set Screws supplied prior to 7/07.

⁶ Removed from assembly; no longer needed (9/98).

⁷ 1" long key S31027 replaces S03060 3/4" long key originally supplied prior to LT30HD and LT40HD Rev. G6.05.

⁸ Grade 5 Bolt replaces F05006-5 Grade 2 Bolt originally supplied to improve durability.

⁹ 24 oz. required for complete oil replacement.

SECTION 7 FEED SYSTEM & TRACK ROLLERS

7.1 Upper Track Rollers And Wipers

LT30HD
LT40HD

Rev. H2.00 - J7.00
Rev. H2.00 - J8.00

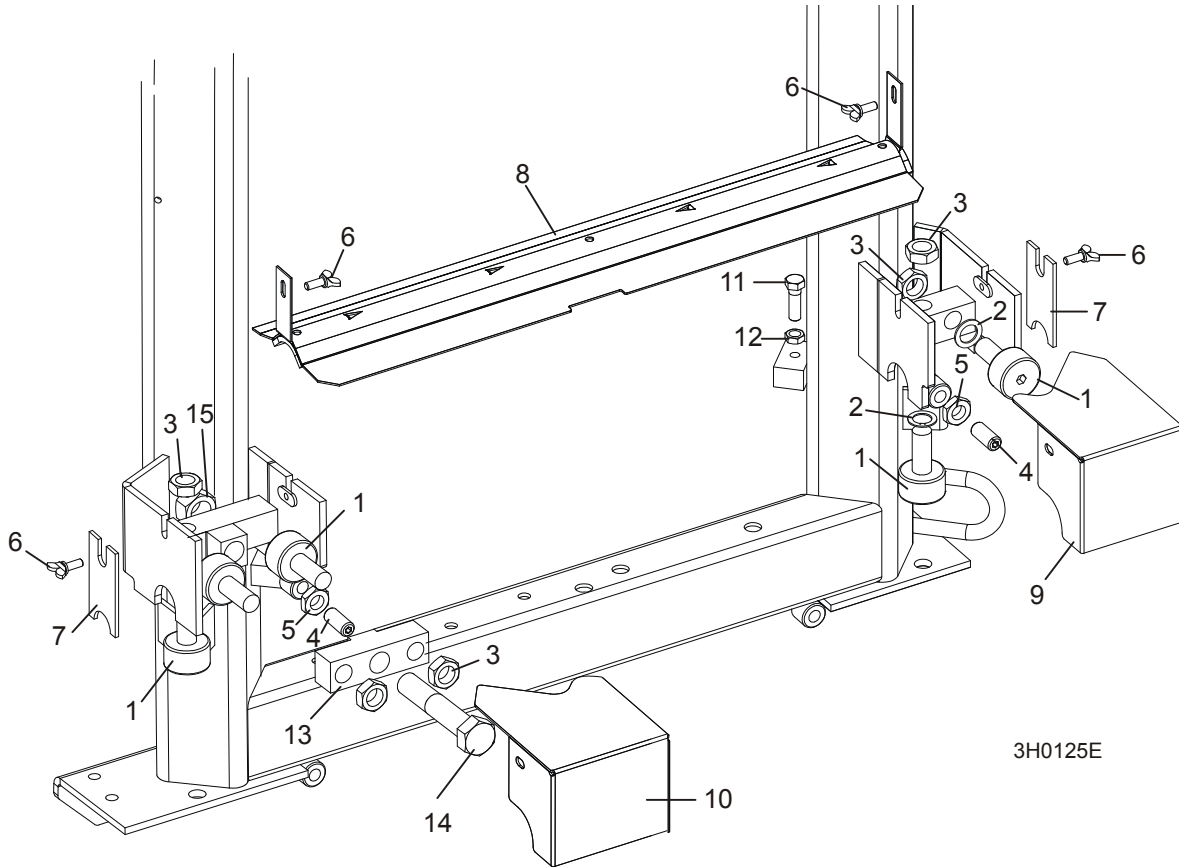

REF	DESCRIPTION (◆ Indicates Parts Available In Assemblies Only)	PART #	QTY.	
1	ROLLER, TRACK CAM BEARING	012797 ¹	5	
2	SHIM, 5/8" X 1" X .062"	016510 ²	2	
3	NUT, 5/8-18 HEX JAM	F05010-11	5	
4	SCREW, 1/2-13 X 1 1/4" OVAL POINT SET	F05008-5	2	
5	NUT, 1/2-13 HEX JAM	F05010-31	2	
6	SCREW, 1/4-20 X 5/8" THUMB	F05005-64	4	
7	WIPER, PLASTIC TRACK	M04113	2	
8	COVER, MIDDLE TRACK OILER ASSEMBLY	A09918	1	
	Cover, Middle Track Oiler	S09917	1	◆
	Wiper, Middle Track Felt	S09915	1	
9	HOUSING, UPPER TRACK ROLLER REAR	012999	1	

7 Feed System & Track Rollers

Upper Track Rollers And Wipers

10	HOUSING, UPPER TRACK ROLLER FRONT	016285	1	
11	BOLT, 3/8-16 X 1 1/4" HEX HEAD	F05007-2	2	
12	NUT, 3/8-16 HEX JAM	F05010-29	2	
13	BLOCK, UPPER ROLLER PIVOT	016501 ³	1	
	BLOCK, UPPER ROLLER PIVOT	015728 ³	1	
14	BOLT, 3/4-10 X 4" HEX HEAD GRADE 5	F05013-3	1	
15	NUT, 3/4-10 SELF LOCKING	F05010-80	1	

¹ McGill unit directly replaces P12843 RBC unit originally supplied (1/00).

² Shims added LT30HD/40HD Rev. H7.00.

³ Use 016501 pivot block for LT30HD/40HD Rev. H7.00+. Use 015728 pivot block for prior revision mills.

7.2 Upper Track Rollers And Wipers

LT30HD
LT40HD

Rev. G1.00 - H1.00
Rev. G1.00 - H1.00

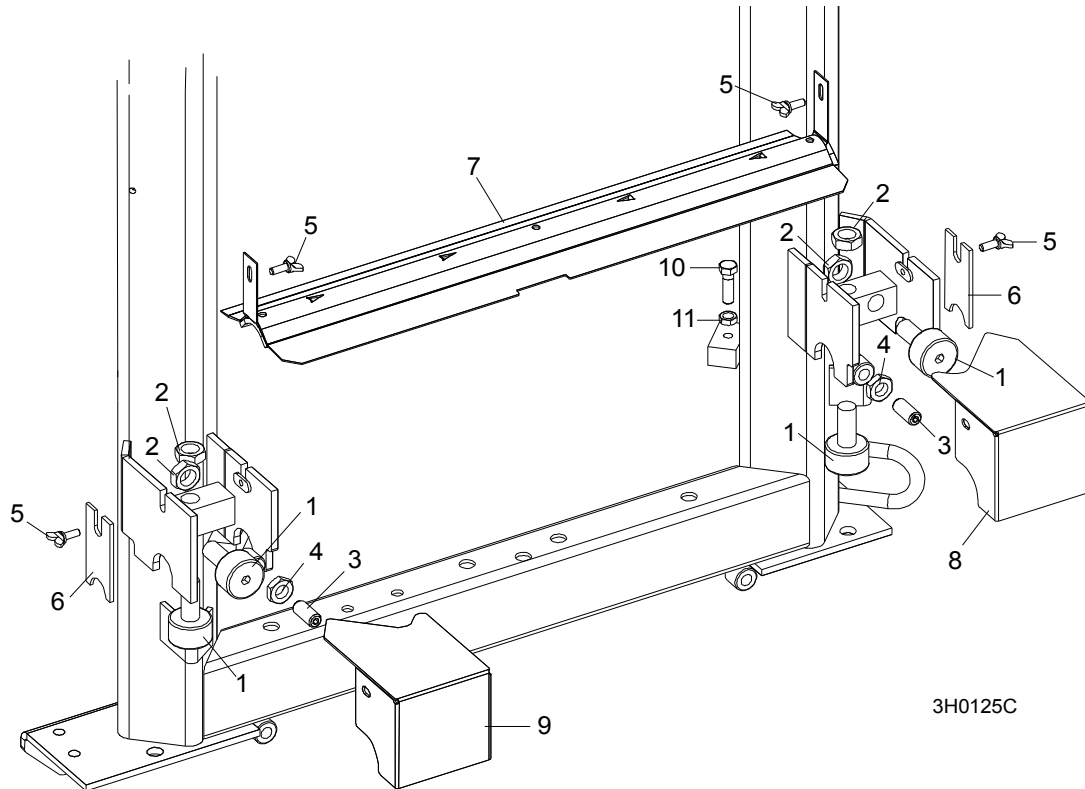

REF	DESCRIPTION (◆ Indicates Parts Available In Assemblies Only)	PART #	QTY.	
1	ROLLER, TRACK CAM BEARING	012797 ¹	4	
2	NUT, 5/8-18 HEX JAM	F05010-11	4	
3	SCREW, 1/2-13 X 1 1/4" OVAL POINT SET	F05008-5	2	
4	NUT, 1/2-13 HEX JAM	F05010-31	2	
5	SCREW, 1/4-20 X 5/8" THUMB	F05005-64	4	
6	WIPER, PLASTIC TRACK	M04113	2	
7	COVER, MIDDLE TRACK OILER ASSEMBLY	A09918	1	
	Cover, Middle Track Oiler	S09917	1	◆
	Wiper, Middle Track Felt	S09915	1	
8	HOUSING, UPPER TRACK ROLLER FRONT	012999	1	
9	HOUSING, UPPER TRACK ROLLER REAR	012998	1	
10	BOLT, 3/8-16 X 1 1/4" HEX HEAD	F05007-2	2	
11	NUT, 3/8-16 HEX JAM	F05010-29	2	

¹ McGill unit directly replaces P12843 RBC unit originally supplied (1/00).

7.3 Power Feed Assembly

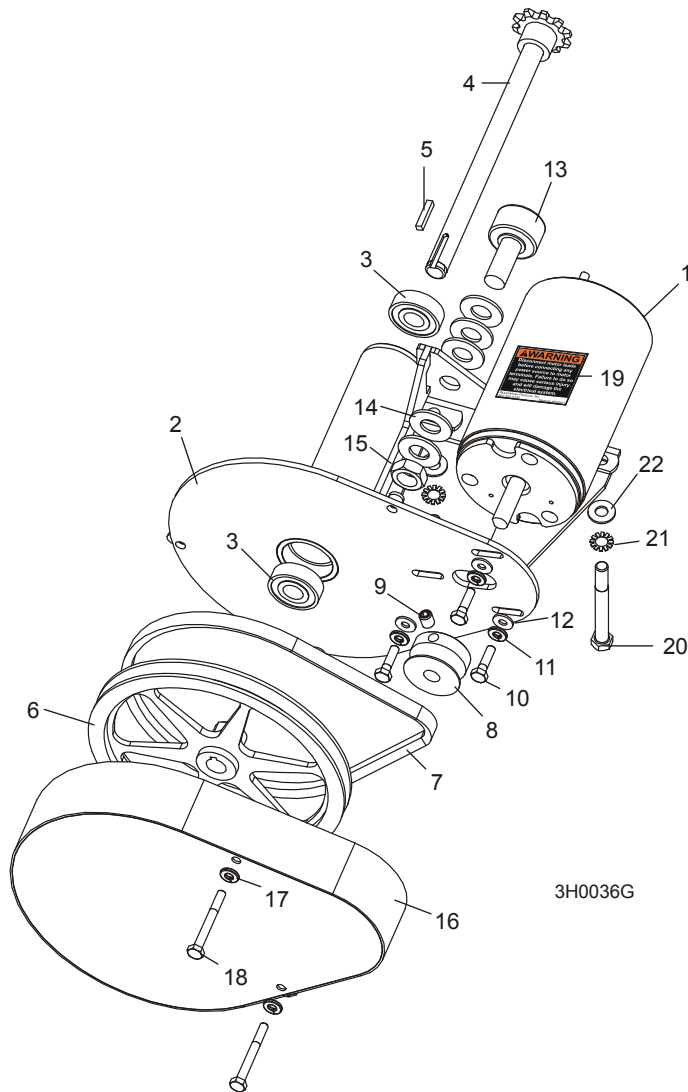

REF	DESCRIPTION (◆ Indicates Parts Available In Assemblies Only)	PART #	QTY.	
	POWER FEED ASSEMBLY	A11603	1	
1	Motor, Power Feed	006747 ¹	1	
	Brush Kit, 12V Motor (2008)	061794 ¹	1	
	Brush Kit, 12V Motor (2007)	006619 ¹	1	
	Brush Kit, 12V Motor	A09086 ¹	1	
	Brush Holder, Motor	034000 ¹	1	◆
	Screw, 5/16-18 x 3/8" Socket Head Set Oval Point	F05006-40	2	
2	Bracket, Power Feed Mount	W11605	1	

3	Bearing, 5/8" 6203-2NSL	P06030-1	2	
	Shaft Assembly, Power Feed with Key	016067 ²	1	
4	Shaft, Power Feed With Sprocket	W11610	1	◆
5	Key, 3/16" Square x 1" Long	S31027	1	
6	Pulley, 8" Power Feed	P04343	1	
7	Belt, 4L280 V	P04031	1	
8	Pulley, Power Feed Motor	S09579	1	
9	Screw, 3/8-16 X 1/2" Cup Point Socket Set	F05007-12	1	
10	Bolt, 1/4-20 X 1" Hex Head Grade 5	F05005-101	3	
11	Washer, 1/4" Split Lock	F05011-14	3	
12	Washer, 1/4" SAE Flat	F05011-11	3	
13	Bearing, 1 1/2" Cam Follower	012797 ³	1	
14	Washer, 5/8" SAE Flat	F05011-5	6	
15	Nut, 5/8-11 Hex Jam	F05010-11	1	
16	Guard, Power Feed Belt	W11613	1	
17	Washer, 1/4" Split Lock	F05011-14	2	
18	Bolt, 1/4-20 X 2 1/4" Hex Head Grade 2	F05005-32	2	
19	Decal, Disconnect Motor Leads Warning	024431	1	
20	Bolt, 3/8-16 X 3 1/2" Hex Head Grade 8	F05007-6 ⁴	2	
21	Washer, 3/8" Star Lock	F05011-36 ⁴	2	
22	Washer, 3/8" SAE Flat	F05011-3 ⁴	2	

¹ Motor 006747 replaces Motor 014359 supplied until 11/08. Order brush kit Part No. A09086 for sawmills built prior to 7/2007 equipped with motors that do not have red and black terminals and are not labeled "Current Applications". Order brush kit Part No. 006619 for sawmills built between 8/2007 and 11/2008 with motors equipped with red and black terminals and not labeled "Current Applications". Order brush kit Part No. 061794 for sawmills built after 11/2008 and/or equipped with motors labeled "Current Applications". Brush Holder 034000 applies only to original 014359 motor and is no longer available (vendor discontinued 3/09).

² Square key replaces P04101-1 #606 Woodruff key. Shaft weldment modified to accommodate key change (LT30HD/40HD rev. G6.04).

³ Replaces P12843 originally supplied.

⁴ Mounting hardware included in power feed assembly. Star Washer F05011-36 replaces Split Lock Washer F05011-4 originally supplied (11/03),

7.4 Feed Chain/Stop

LT30HD

LT40HD

Rev. G9.00 - J7.00

Rev. G9.00 - J8.00

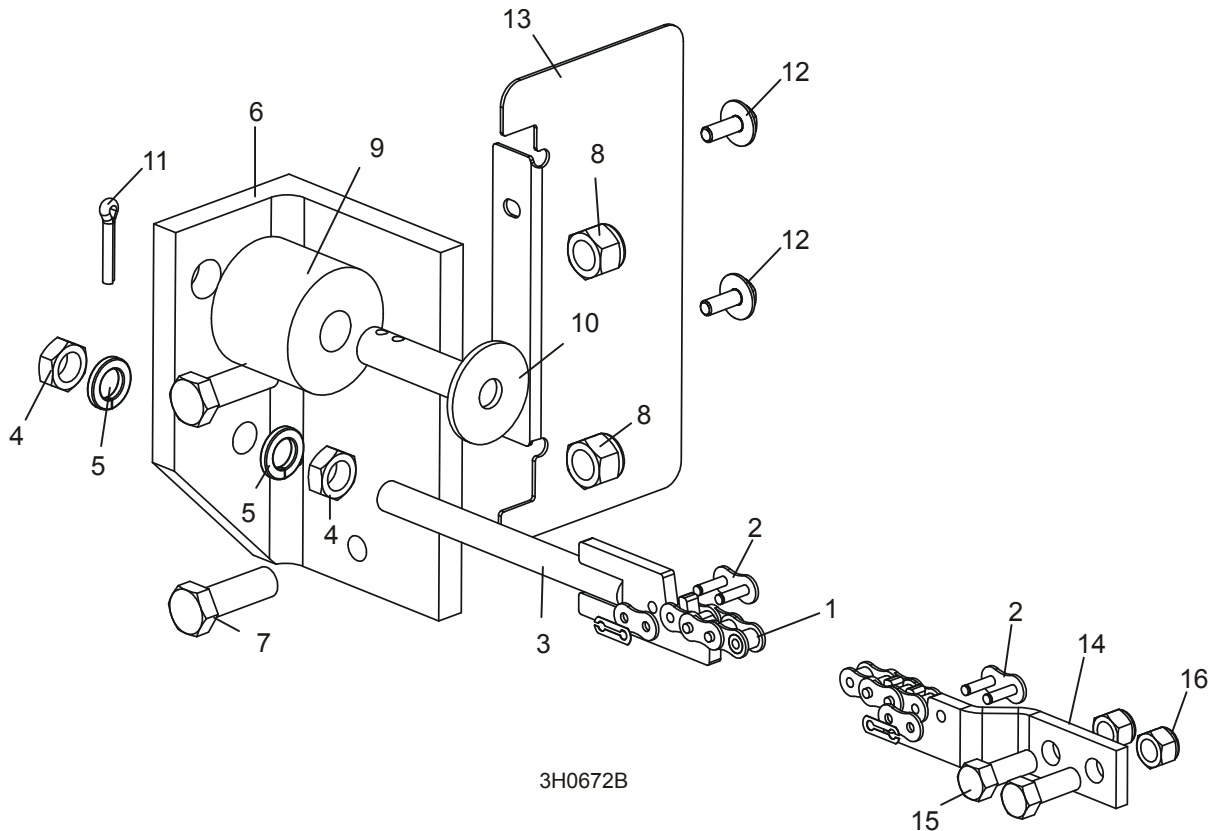

REF	DESCRIPTION (◆ Indicates Parts Available In Assemblies Only)	PART #	QTY.
1	CHAIN, #40 X 215.5" LT30 FEED	014744	1
	CHAIN, #40 X 267.5" LT40 FEED	014745	1
2	LINK, #40 MASTER	P04200	2
3	TENSIONER WELDMENT, POWER FEED CHAIN	015721	1
4	NUT, 1/2-20 HEX JAM	F05010-16	2
5	WASHER, 1/2" SPLIT LOCK	F05011-9	2
6	BRACKET, 4 X 8 END CAP	016165	1
7	BOLT, 1/2-13 X 1 1/2" HEX HEAD GRADE 5	F05008-33	2
8	NUT, 1/2-13 HEX NYLON LOCK	F05010-8	2
	STOP KIT, RUBBER CARRIAGE	K09630	2
9	Stop, Rubber Carriage	P12165	1
10	Pin, Rubber Carriage Stop	W09293	1
11	Pin, 3/16" X 1" Cotter	F05012-21	1

12	BOLT, 1/4-20 X 3/4" WITH CONICAL WASHER	F05005-134	2	
13	CAP, 4 X 8" REAR FORMED	016164	1	
14	BRACKET, FRONT FEED CHAIN MOUNT	015008	1	
15	BOLT, 3/8-16 X 1" HEX HEAD	F05007-7	2	
16	NUT, 3/8-16 HEX NYLON LOCK	F05010-10	2	

7.5 Feed Chain/Stop

LT30HD
LT40HD

Rev. G6.00 - G8.00
Rev. G6.00 - G8.00

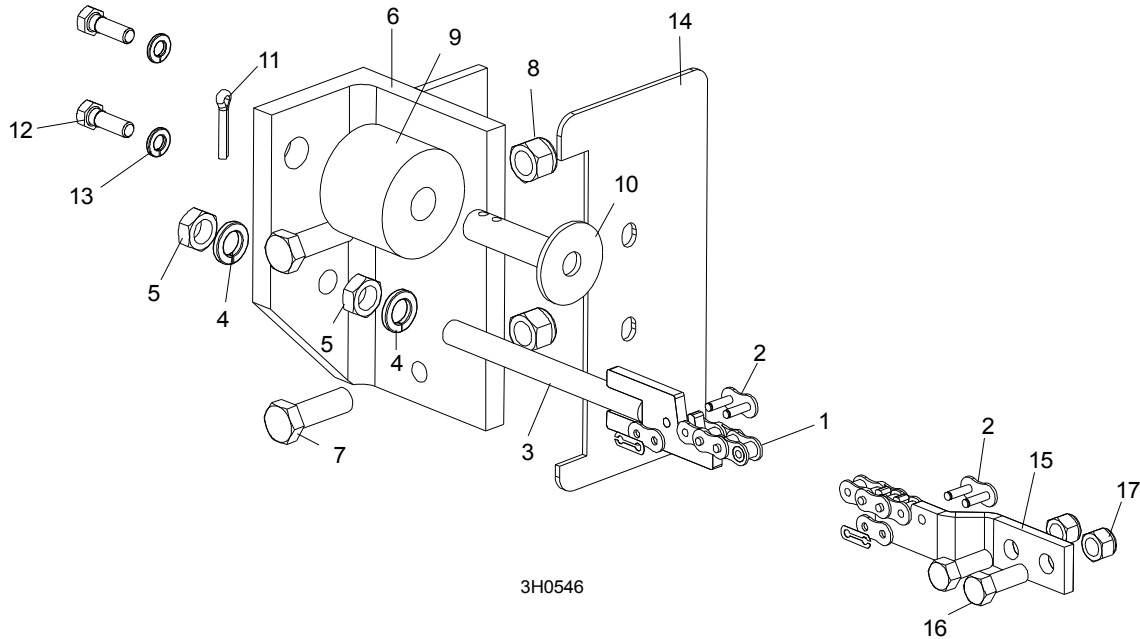

REF	DESCRIPTION (◆ Indicates Parts Available In Assemblies Only)	PART #	QTY.
1	CHAIN, #40 X 215.5" LT30 FEED	014744	1
	CHAIN, #40 X 208.5" LT30 FEED	P10407 ¹	1
	CHAIN, #40 X 267.5" LT40 FEED	014745	1
	CHAIN, #40 X 260.5" LT40 FEED	P10409 ¹	1
2	LINK, #40 MASTER	P04200	2
3	TENSIONER WELDMENT, POWER FEED CHAIN	015721	1
4	NUT, 1/2-20 HEX JAM	F05010-16	2
5	WASHER, 1/2" SPLIT LOCK	F05011-9	2
6	BRACKET, FEED CHAIN REAR MOUNT	015626 ²	1
7	BOLT, 1/2-13 X 1 1/2" HEX HEAD GRADE 5	F05008-33	2
8	NUT, 1/2-13 HEX NYLON LOCK	F05010-8	2
	STOP KIT, RUBBER CARRIAGE	K09630	2
9	Stop, Rubber Carriage	P12165	1
10	Pin, Rubber Carriage Stop	W09293	1
11	Pin, 3/16" X 1" Cotter	F05012-21	1
12	BOLT, 5/16-18 X 1" HEX HEAD	F05006-1	2
13	WASHER, 5/16" SPLIT LOCK	F05011-13	2
14	PLATE, 4 X 8 TUBE COVER	015956 ²	1
15	BRACKET, FRONT FEED CHAIN MOUNT	015008	1

16	BOLT, 3/8-16 X 1" HEX HEAD	F05007-7	2	
17	NUT, 3/8-16 HEX NYLON LOCK	F05010-10	2	

¹ Use on Standard mills prior to LT30HD/40HD Rev. G6.05.

² Stop bracket and tube cover plate redesigned for easier manufacturability and common usage for standard and super model mills.

7.6 Feed Chain/Stop

LT30HD
LT40HD

Rev. G1.00 - G5.02
Rev. G1.00 - G5.02

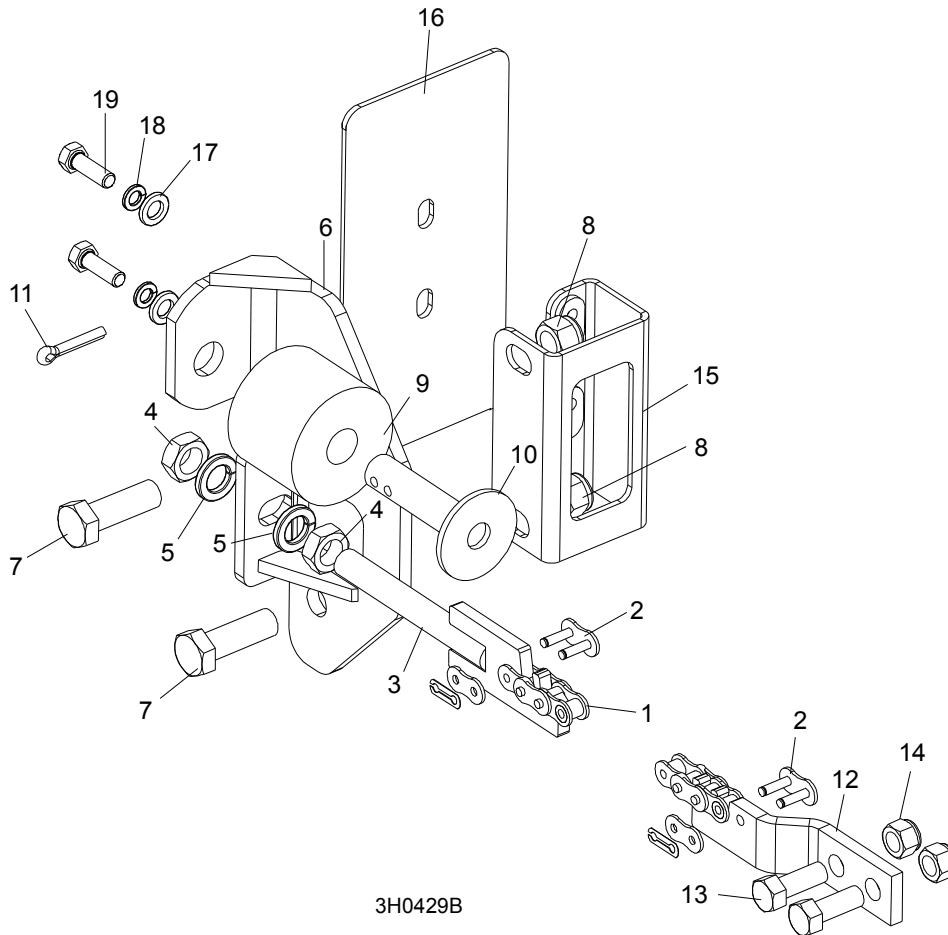

REF	DESCRIPTION (◆ Indicates Parts Available In Assemblies Only)	PART #	QTY.
	CHAIN KIT, LT30 FEED	K10408	1
	CHAIN KIT, LT40 FEED	K10410	1
1	Chain, #40 X 208.5" LT30 Feed	P10407	1
	Chain, #40 X 260.5" LT40 Feed	P10409	1
2	Link, #40 Master	P04200	2
3	Tensioner Weldment, Power Feed Chain	015520 ¹	1
4	Nut, 1/2-20 Hex Jam	F05010-16	2
5	Washer, 1/2" Split Lock	F05011-9	2
6	BRACKET, FEED CHAIN REAR MOUNT	015262	1
7	BOLT, 1/2-13 X 1 1/2" HEX HEAD GRADE 5	F05008-33	2
8	NUT, 1/2-13 HEX NYLON LOCK	F05010-8	2
	STOP KIT, RUBBER CARRIAGE	K09630	2

9	Stop, Rubber Carriage	P12165	1	
10	Pin, Rubber Carriage Stop	W09293	1	
11	Pin, 3/16" X 1" Cotter	F05012-21	1	
12	BRACKET, FRONT FEED CHAIN MOUNT	015008	1	
13	BOLT, 3/8-16 X 1" HEX HEAD	F05007-7	2	
14	NUT, 3/8-16 HEX NYLON LOCK	F05010-10	2	
15	BRACKET WELDMENT, REAR MAIN TUBE COVER MOUNT	015021	1	
16	COVER, REAR MAIN TUBE	015023	1	
17	WASHER, 5/16" SAE FLAT	F05011-17	2	
18	WASHER, 5/16" SPLIT LOCK	F05011-13	2	
19	BOLT, 5/16-18 X 1" HEX HEAD	F05006-1	2	

¹ Replaces S09569 tensioner rod originally supplied prior to LT30HD/40HD rev. G2.01.

7.7 Lower Track Rollers

LT30HD
LT40HD

Rev. H7.00 - J7.00
Rev. H7.00 - J7.00

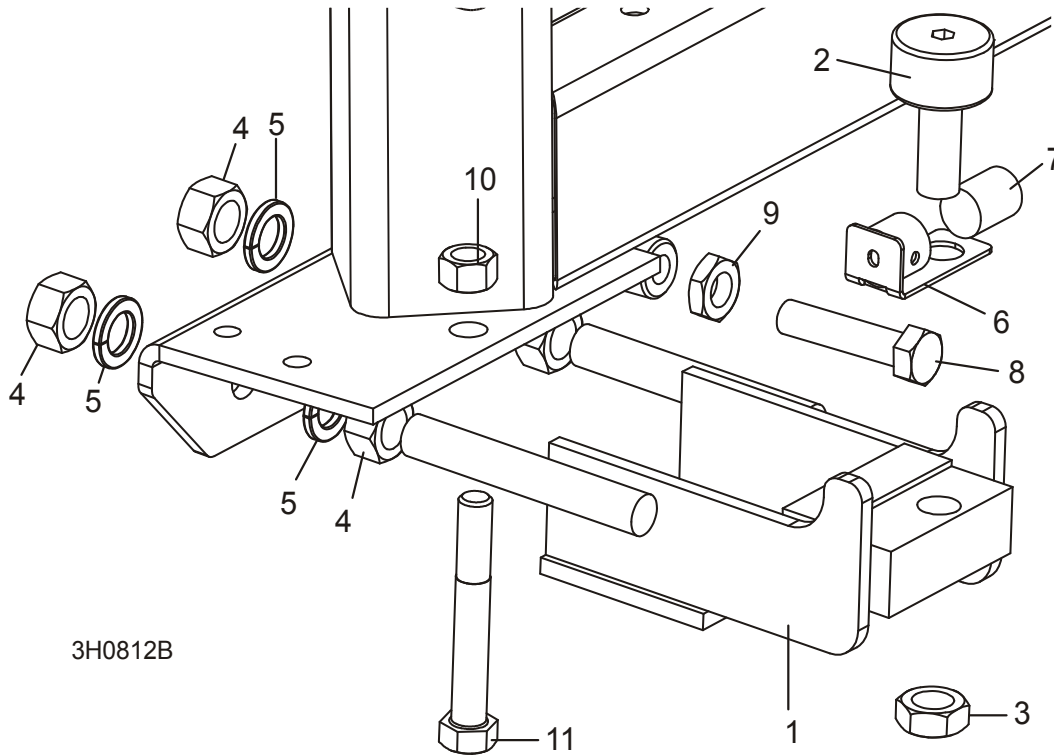

3H0812B

REF	DESCRIPTION (◆ Indicates Parts Available In Assemblies Only)	PART #	QTY.	
	ROLLER ASSEMBLY, LOWER TRACK	012995	2	
1	Bracket, Lower Track Roller Mounting	012982	1	◆
2	Roller, Track Cam Bearing	012797	1	
3	Nut, 5/8-18 Hex Jam	F05010-11	1	
4	Nut, 5/8-11 Hex	F05010-5	4	
5	Washer, 5/8" Split Lock Grade 8	F05011-118 ¹	4	
6	Bracket Weldment, Lower Track Roller Wiper	033374	1	
7	Wiper, Round Gray Felt	033375	1	
8	BOLT, 1/2-13 X 2 1/4" HEX HEAD FULL THREAD	F05008-2	2	
9	NUT, 1/2-13 HEX JAM	F05010-31	2	
10	NUT, 1/2-13 HEX LOCK	F05010-3	2	
11	BOLT, 1/2-13 X 3 1/2" HEX HEAD GRADE 5	F05008-61	2	

¹ Grade 8 washers replace F05011-27 originally supplied to improve durability.

7.8 Lower Track Rollers

LT30HD
LT40HD

Rev. G1.00 - H6.02
Rev. G1.00 - H6.02

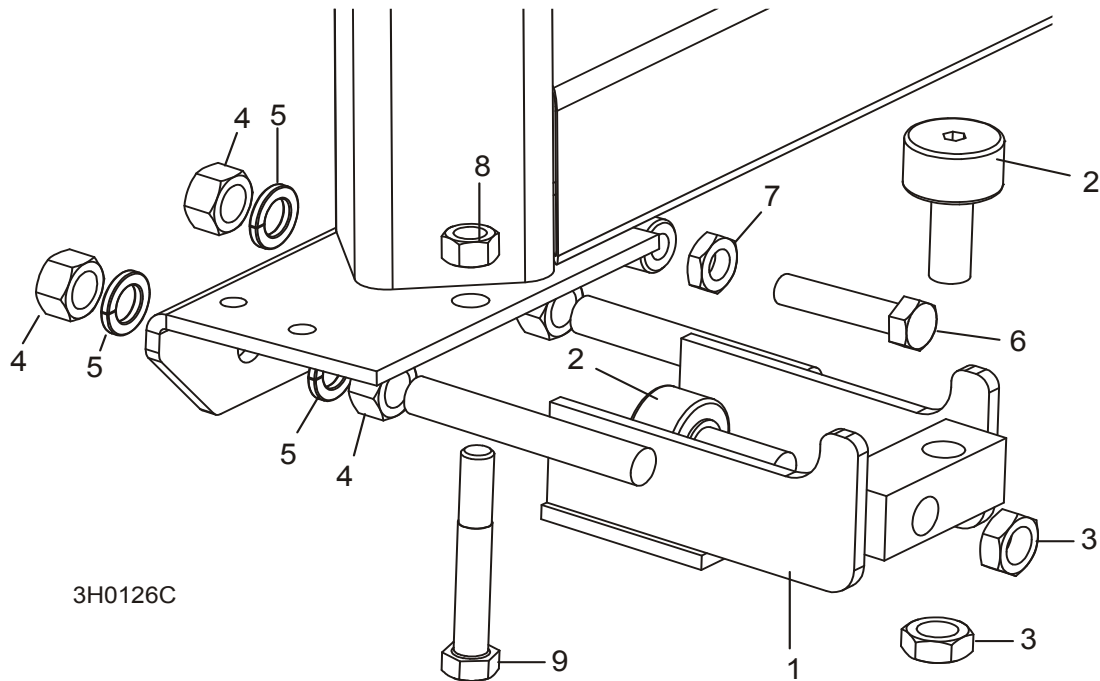

REF	DESCRIPTION (◆ Indicates Parts Available In Assemblies Only)	PART #	QTY.	
	ROLLER ASSEMBLY, LOWER TRACK	012995 ¹	2	
1	Bracket, Lower Track Roller Mounting	012982	1	◆
2	Roller, Track Cam Bearing	012797 ²	2	
3	Nut, 5/8-18 Hex Jam	F05010-11	2	
4	Nut, 5/8-11 Hex	F05010-5 ³	4	
5	Washer, 5/8" Split Lock Grade 8	F05011-118 ³	4	
6	BOLT, 1/2-13 X 2 1/4" HEX HEAD FULL THREAD	F05008-2	2	
7	NUT, 1/2-13 HEX JAM	F05010-31	2	
8	NUT, 1/2-13 HEX LOCK	F05010-3	2	
9	BOLT, 1/2-13 X 3 1/2" HEX HEAD GRADE 5	F05008-61	2	

¹ Lower track roller mounting bracket revised to accommodate new wiper assembly added LT30HD/40HD Rev. H7.00. Bracket includes stop block which replaces the bottom track roller ([See Section 7.7](#)).

² McGill unit directly replaces P12843 RBC unit originally supplied (1/00).

³ Each of two F05010-4 self locking nuts originally supplied prior to LT30HD/40HD Rev. G4.00 has been replaced by a F05011-27 split lock washer and a F05010-5 hex nut to ensure lock retention after repeated adjustments. Grade 8 washers replace F05011-27 originally supplied to improve durability.

8 Bed Frame Assembly

Bed Rail Assembly, Front And Rear

SECTION 8 BED FRAME ASSEMBLY

8.1 Bed Rail Assembly, Front And Rear

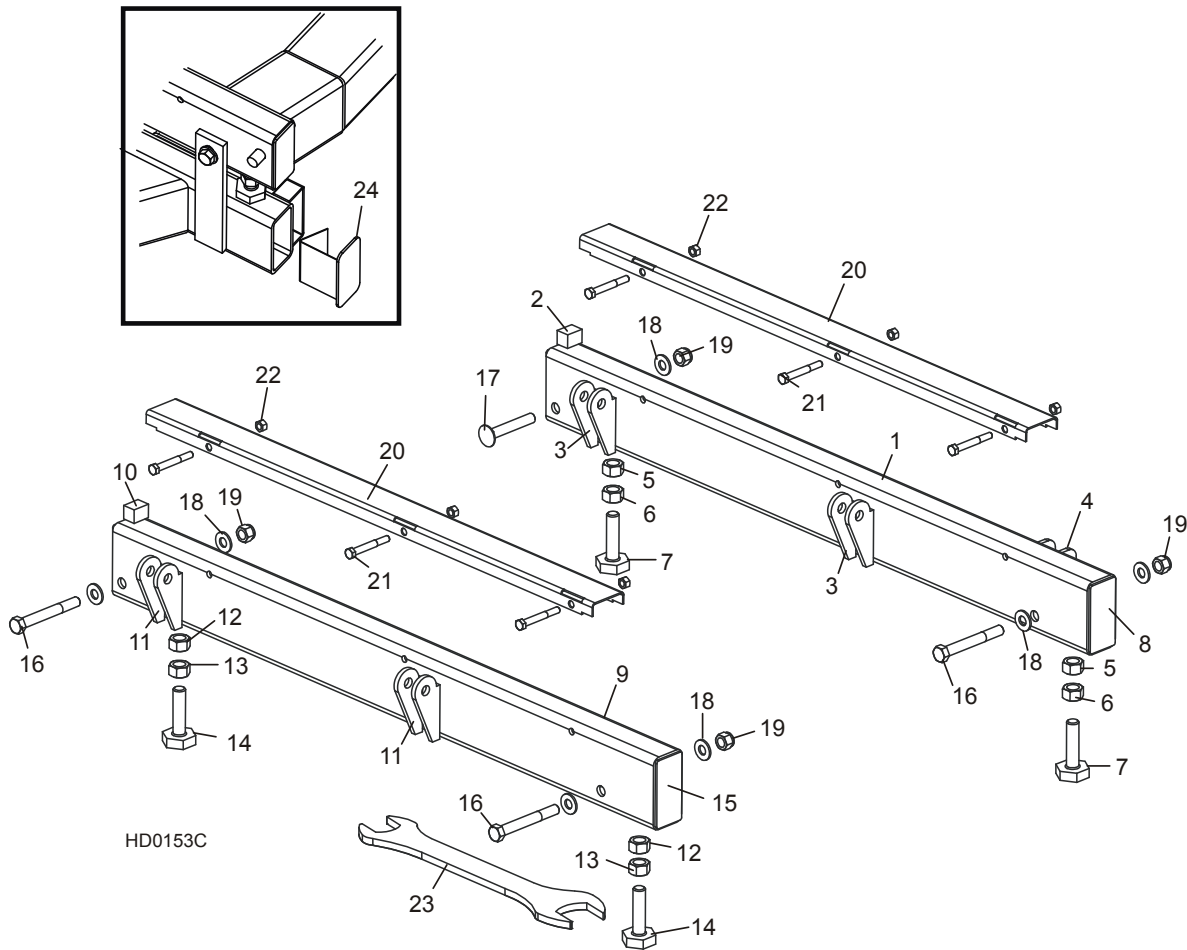

REF	DESCRIPTION (◆ Indicates Parts Available In Assemblies Only)	PART #	QTY.	
	BED RAIL ASSEMBLY, REAR PAINTED	014467	1	
1	Bed Rail Tube, Long	015974	1	◆
2	Block, Log Stop	S09034	1	
3	Bracket, Roller Toe Board Mount	S13021	4	◆
4	Bracket, Saw Head Rest Pin Mount	014150	2	◆
5	Nut, 5/8-11 Pilot Weld	F05010-84 ¹	2	
6	Nut, 5/8-11 Hex	F05010-5 ¹	2	
7	Bolt, Bed Rail Adjustment	S13006 ¹	2	
8	Plate, Bed Rail End Cap	S04058	2	◆
	BED RAIL ASSEMBLY, FRONT PAINTED	014455	1	
9	Bed Rail Tube, Long	015974	1	◆

Bed Frame Assembly 8

Bed Rail Assembly, Front And Rear

10	Block, Log Stop	S09034	1	
11	Bracket, Roller Toe Board Mount	S13021	4	◆
12	Nut, 5/8-11 Pilot Weld	F05010-84 ¹	2	
13	Nut, 5/8-11 Hex	F05010-5 ¹	2	
14	Bolt, Bed Rail Adjustment	S13006 ¹	2	
15	Plate, Bed Rail End Cap	S04058	2	◆
16	BOLT, 1/2-13 X 4" HEX HEAD	F05008-78 ²	3	
17	BOLT, 1/2-13 X 3 1/2" CARRIAGE	F05008-94 ³	1	
18	WASHER, 1/2" SAE FLAT	F05011-2	7	
19	NUT, 1/2-13 NYLON LOCK	F05010-8	4	
20	COVER, STAINLESS STEEL BED RAIL	016898 ⁴	2	
21	BOLT, 5/16-18 X 2 1/2" HEX HEAD	F05006-10	6	
22	NUT, 5/16-18 HEX LOCK	F05010-6	6	
23	WRENCH, BED RAIL ADJUSTMENT	015970	1	
24	CAP WELDMENT, BED RAIL REMOVABLE END	014652	2	

¹ Bed Rail Adjustment Bolt S13006 zinc-plated 11/99. Two unplated 5/8-11 Hex Nuts F05010-54 replaced with one 5/8-11 Pilot Weld Nut F05010-84 and one 5/8-11 Zinc-Plated Hex Nut. Component parts replace assembly A09775 previously supplied.

² F05008-78 Grade 5 bolt replaces F05008-26 bolt originally supplied prior to 5/03.

³ Used on rear bed rail to allow clearance for optional side support rollers.

⁴ Longer rail cover 016898 replaces S09944 supplied prior to LT30HD Rev. J4.00 and LT40HD Rev. J5.00.

8 Bed Frame Assembly

Bed Rail Assembly, Middle Front

8.2 Bed Rail Assembly, Middle Front

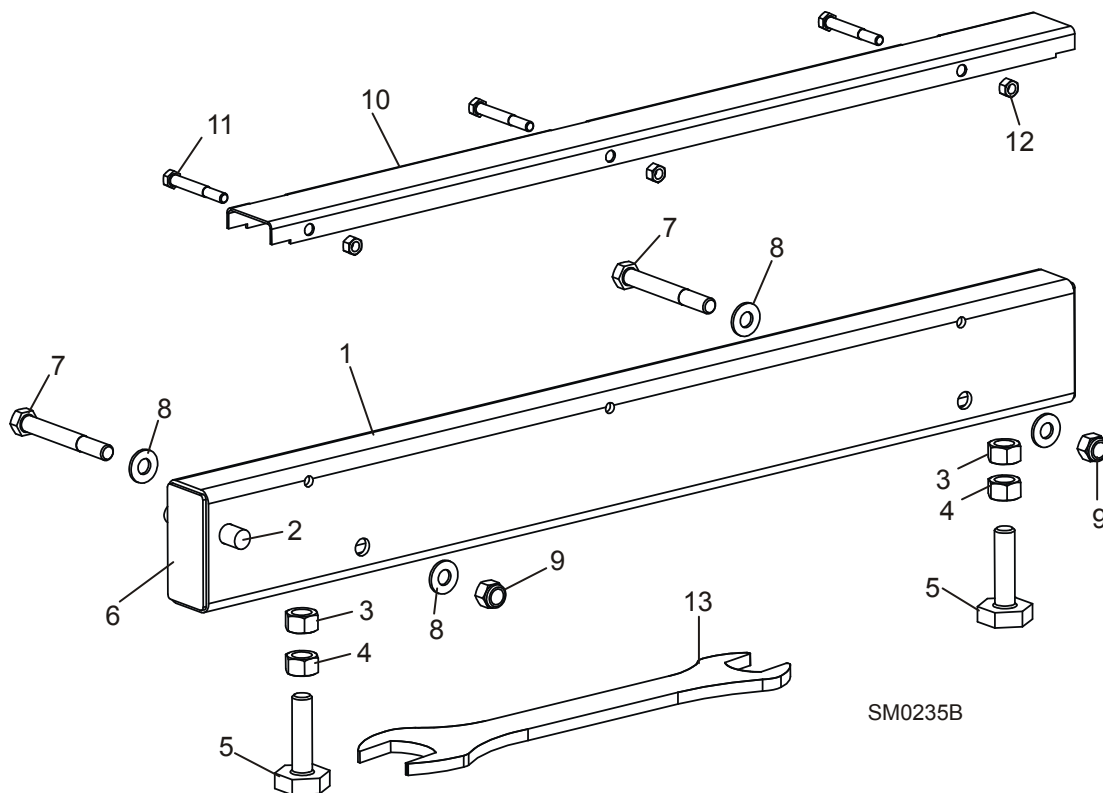

REF	DESCRIPTION (◆ Indicates Parts Available In Assemblies Only)	PART #	QTY.	
	BED RAIL ASSEMBLY, FRONT MIDDLE	A09566	1	
1	Bed Rail Tube, Short	S09103	1	◆
2	Pin, Ramp Mount	S04030	1	
3	Nut, 5/8-11 Pilot Weld	F05010-84 ¹	2	
4	Nut, 5/8-11 Hex	F05010-5 ¹	2	
5	Bolt, Bed Rail Adjustment	S13006 ¹	2	
6	Plate, Bed Rail End Cap	S04058	2	◆
7	BOLT, 1/2-13 X 4" HEX HEAD GRADE 5	F05008-78 ²	2	
8	WASHER, 1/2" SAE FLAT	F05011-2	4	
9	NUT, 1/2-13 NYLON LOCK	F05010-8	2	
	COVER ASSEMBLY, STAINLESS STEEL BED RAIL (LONG)	A09956	1	
10	Cover, Stainless Steel Bed Rail	S09944	1	◆
11	Bolt, 5/16-18 X 2 1/2" Hex Head	F05006-10	3	
12	Nut, 5/16-18 Hex Lock	F05010-6	3	
13	WRENCH, BED RAIL ADJUSTMENT	015970	1	

¹ Bed Rail Adjustment Bolt S13006 zinc-plated 11/99. Two unplated 5/8-11 Hex Nuts F05010-54 replaced with one 5/8-11 Pilot Weld Nut F05010-84 and one 5/8-11 Zinc-Plated Hex Nut. Component parts replace assembly A09775 previously supplied.

² F05008-78 Grade 5 bolt replaces F05008-26 bolt originally supplied prior to 5/03.

8.3 Bed Rail Assembly, Middle Rear

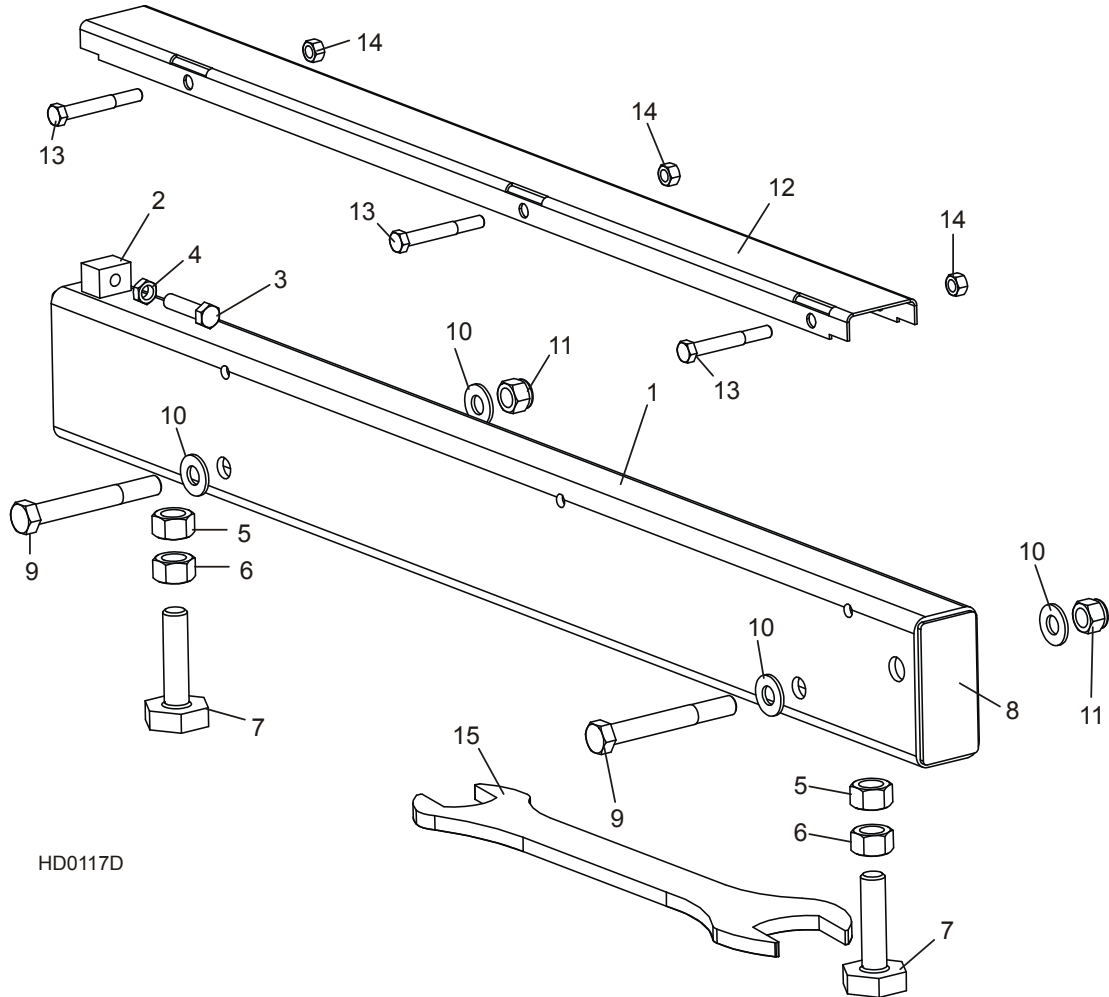

HD0117D

REF	DESCRIPTION (◆ Indicates Parts Available In Assemblies Only)	PART #	QTY.	
	BED RAIL ASSEMBLY, REAR MIDDLE PAINTED	015757	1	
1	Bed Rail Tube, Short	014640	1	◆
2	Block, Log Stop w/Threaded Hole	014639	1	◆
3	Bolt, 3/8-16 x 1 1/2 Full Thead Hex Head	F05007-17	1	
4	Nut, 3/8-16 Hex Jam	F05010-29	1	
5	Nut, 5/8-11 Pilot Weld	F05010-84 ¹	2	
6	Nut, 5/8-11 Hex	F05010-5 ¹	2	
7	Bolt, Bed Rail Adjustment	S13006 ¹	2	
8	Plate, Bed Rail End Cap	S04058	2	◆
9	BOLT, 1/2-13 X 4" HEX HEAD GRADE 5	F05008-78 ²	2	
10	WASHER, 1/2" SAE FLAT	F05011-2	4	

8

Bed Frame Assembly*Bed Rail Assembly, Middle Rear*

11	NUT, 1/2-13 NYLON LOCK	F05010-8	2	
	COVER ASSEMBLY, STAINLESS STEEL BED RAIL (LONG)	A09956	1	
12	Cover, Stainless Steel Bed Rail	S09944	1	◆
13	Bolt, 5/16-18 X 2 1/2" Hex Head	F05006-10	3	
14	Nut, 5/16-18 Hex Lock	F05010-6	3	
15	WRENCH, BED RAIL ADJUSTMENT	015970	1	

¹ Bed Rail Adjustment Bolt S13006 zinc-plated 11/99. Two unplated 5/8-11 Hex Nuts F05010-54 replaced with one 5/8-11 Pilot Weld Nut F05010-84 and one 5/8-11 Zinc-Plated Hex Nut. Component parts replace assembly A09775 previously supplied.

² F05008-78 Grade 5 bolt replaces F05008-26 bolt originally supplied prior to 5/03.

8.4 Leg Assembly (Stationary)

LT15BS

Rev. E.00+

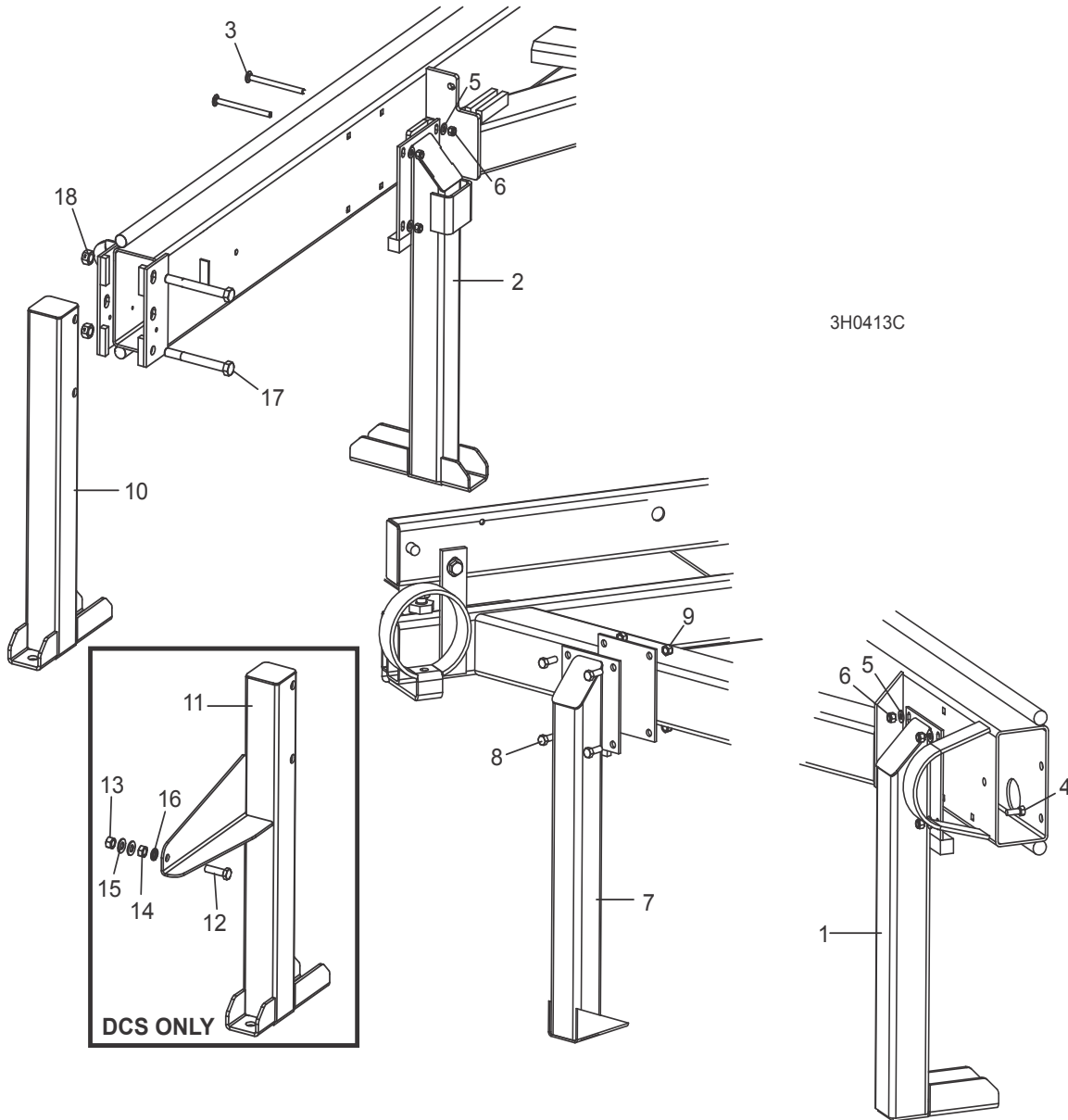

REF	DESCRIPTION (◆ Indicates Parts Available In Assemblies Only)	PART #	QTY.
1	LEG, LONG STATIONARY (1 REQ'D FOR LT30HD; 3 REQ'D FOR LT40HD)	W09513 ¹	1/3
2	LEG, LONG STATIONARY W/BOARD RETURN TABLE BRACKET	015091 ¹	1
3	BOLT, 3/8-16 X 5" CARRIAGE HEAD	F05007-113	8/12
4	BOLT, 3/8-16 X 1 1/4" HEX HEAD (REQ'D FOR REAR LT40HD ONLY)	F05007-2 ²	4
5	WASHER, 3/8" SAE FLAT	F05011-3 ³	8/16

8 Bed Frame Assembly

Leg Assembly (Stationary)

6	NUT, 3/8-16 HEX NYLON LOCK	F05010-10	8/16	
7	LEG, SHORT STATIONARY	W09515	2	
8	BOLT, 3/8-16 X 1 1/4" HEX HEAD	F05007-2 ²	8	
9	NUT, 3/8-16 HEX NYLON LOCK	F05010-10	8	
10	LEG, FRONT STATIONARY	W09517 ¹	1	
11	BOLT, 5/8-11 X 5 1/2" HEX HEAD GRADE 5	F05009-11	2	
12	NUT, 5/8-11 HEX LOCK	F05010-4	2	

¹ Leg base plate changed to 1/4" steel and lengthened to improve stability (LT30HD and LT40HD Rev. G6.05).

² Replaces 3/8-16 x 1" Hex Head Grade 2 Bolt (F05007-7) to secure legs with thicker 1/4" mounting plate provided after Rev. H6.00.

³ Washers added on LT30HD and LT40HD Rev. G6.06.

8.5 Pivot Bed Rail Assembly

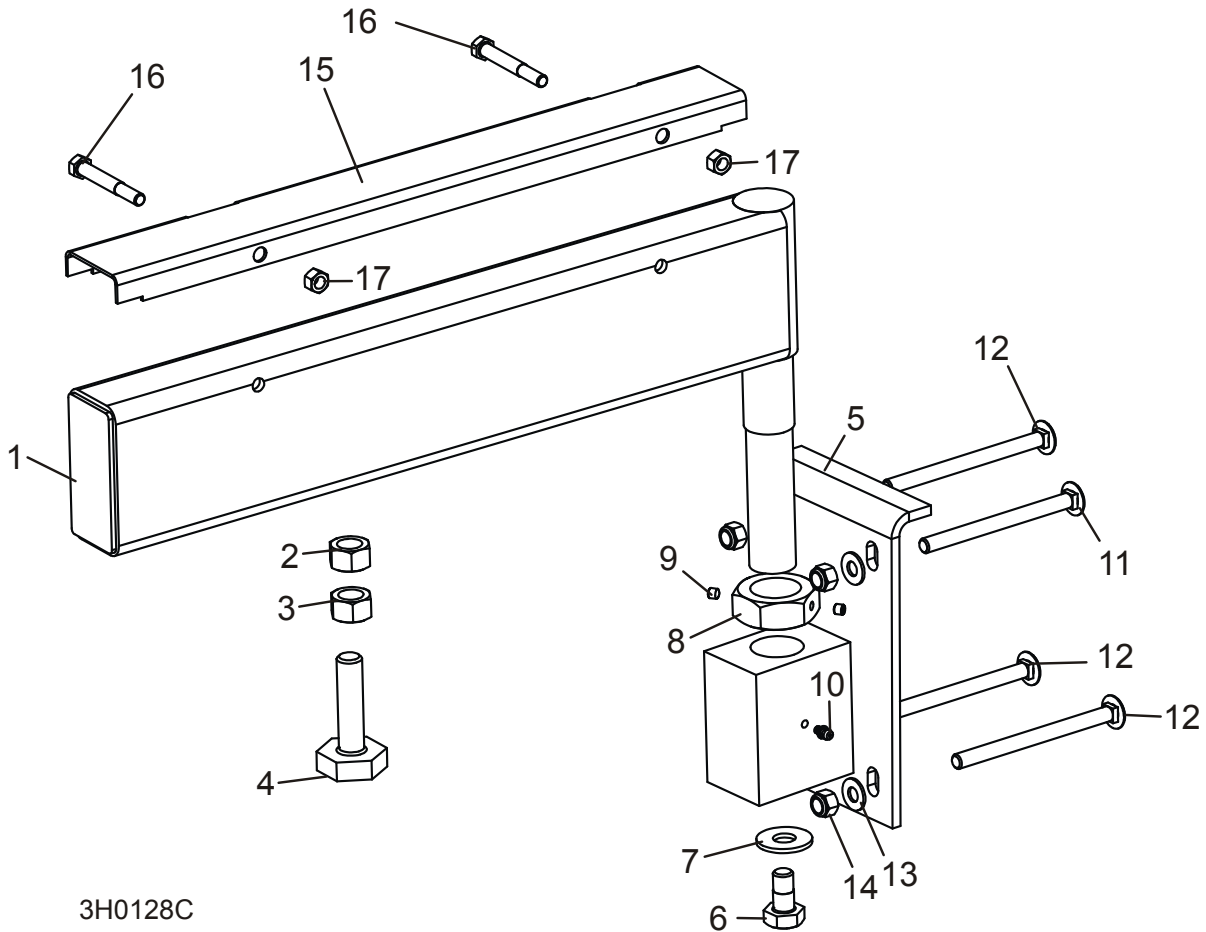

3H0128C

REF	DESCRIPTION (◆ Indicates Parts Available In Assemblies Only)	PART #	QTY.	
	PIVOT BED RAIL ASSEMBLY (LT40HD)	A13015	2	
	PIVOT BED RAIL ASSEMBLY (LT30HD)	012993	2	
1	Pivot Bed Rail Weldment (LT40HD)	W13014	1	◆
	Pivot Bed Rail Weldment (LT30HD)	012992	1	◆
2	Nut, 5/8-11 Pilot Weld	F05010-84 ¹	2	
3	Nut, 5/8-11 Hex	F05010-5 ¹	2	
4	Bolt, Bed Rail Adjustment	S13006 ¹	2	
5	Bracket, Pivot Rail Mounting	W13090	1	
6	Bolt, 1/2-13 x 1" Hex Head Grade 2	F05008-50	1	
7	Washer, 9/16" SAE Flat	F05011-52	1	
8	Nut, Pivot Rail Adjustment	S13016	1	
9	Screw, 1/4-28 x 1/4" Brass Tip Set	F05005-42	2	
10	Fitting, 3/16" Grease	P04107	1	

8

Bed Frame Assembly*Pivot Bed Rail Assembly*

11	BOLT, 3/8-16 X 4 3/4" CARRIAGE HEAD	F05007-114	2	
12	BOLT, 3/8-16 X 5" CARRIAGE HEAD	F05007-113	6	
13	WASHER, 3/8" SAE FLAT	F05011-3 ²	8	
14	NUT, 3/8-16 NYLON LOCK	F05010-10	8	
	COVER KIT, PIVOT RAIL STAINLESS STEEL (LT40HD)	017710	2	
	COVER KIT, PIVOT RAIL STAINLESS STEEL (LT30HD)	015926	2	
15	Cover, Stainless Steel Pivot Bed Rail (LT40HD)	S13012	1	
	Cover, Stainless Steel Pivot Bed Rail (LT30HD)	012994	1	
16	Bolt, 5/16-18 X 2 1/2" Hex Head	F05006-10	2	
17	Nut, 5/16-18 Hex Lock	F05010-6	2	
	WRENCH, BED RAIL ADJUSTMENT (See Section 8.1)	015970	1	

¹ Bed Rail Adjustment Bolt S13006 zinc-plated 11/99. Two unplated 5/8-11 Hex Nuts F05010-54 replaced with one 5/8-11 Pilot Weld Nut F05010-84 and one 5/8-11 Zinc-Plated Hex Nut. Component parts replace assembly A09775 previously supplied.

² Washers added on LT30HD and LT40HD Rev. G6.06.

8.6 Log Side Support Assembly (Manual)

See Section 10.11 for hydraulic side supports

LT30HD
LT40HD

Rev. H8.00 - J7.00
Rev. H8.00 - J8.00

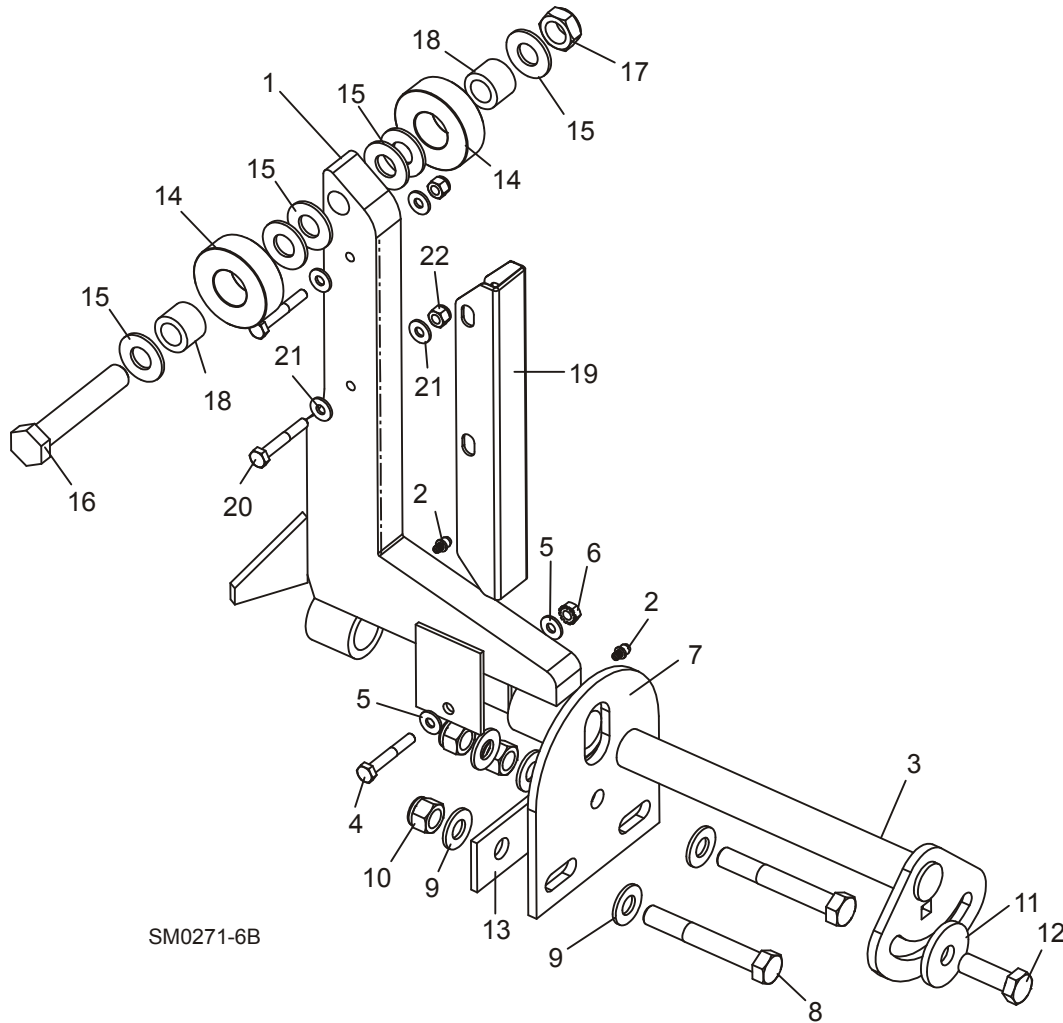

SM0271-6B

REF	DESCRIPTION (◆ Indicates Parts Available In Assemblies Only)	PART #	QTY.
1	SUPPORT, LOG SIDE	015235	2
2	Fitting, 3/16" Grease	P04107	2
	MOUNTING KIT, LOG SIDE SUPPORT	016559 ¹	2
3	Pin, Log Side Support Pivot	016544	1
4	Bolt, 1/4-20 X 1 1/2" Hex Head Grade 5	F05005-4	1
5	Washer, 1/4" SAE Flat	F05011-11	2
6	Nut, 1/4-20 Self Locking	F05010-9	1

8

Bed Frame Assembly

Log Side Support Assembly (Manual)

7	Plate, Log Side Support End	016555	1	
8	Bolt, 1/2-13 X 3 1/2" Hex Head Grade 5	F05008-61	2	
9	Washer, 1/2" SAE Flat	F05011-2	5	
10	Nut, 1/2-13 Hex Nylon Lock	F05010-8	3	
11	Washer, .52" x 1.69"	014632 ²	1	
12	Bolt, 1/2-13 X 1 1/2" Hex Head Grade 5	F05008-33	1	
13	Plate, Side Support Washer Clamp	016558	1	
	ROLLER KIT, SIDE SUPPORT	016562 ³	4	
14	Roller, Side Support	016561	2	
15	Washer, 5/8" SAE Flat	F05011-5 ⁴	6	
16	Bolt, 5/8-11 x 3 3/4" Hex Head Grade 5	F05009-118 ⁵	1	
17	Nut, 5/8-11 Hex Nylon Lock Jam	F05010-96 ⁶	1	
18	Bushing, Bronze 5/8" x 1" x 3/4"	016560	2	
	Bolt, 1/2-13 x 3 1/2" Carriage Head	F05008-94 ³	1	
	Instruction Sheet, Side Support Roller	016562-526	1	
	GUARD KIT, STAINLESS STEEL SIDE SUPPORT (OPTIONAL)	016798 ⁷	1	
19	Guard, Stainless Steel Side Support	016722	4	
20	Bolt, 1/4-20 x 1 3/4" Hex Head	F05005-4	8	
21	Washer, 1/4" SAE Flat	F05011-11	16	
	Washer, 5/8" SAE Flat	F05011-5 ⁴	4	
22	Nut, 1/4-20 Hex Nylon Lock	F05010-69	8	
	Instruction Sheet, Stainless Steel Side Support Guard Retro	016798-1005	1	

¹ Mounting Kit 016559 replaces kit K09344 supplied prior to Rev. H8.00. New mounting pin, plate and clamp plate improve stability of side support adjustment.

² Oversized Washer 014632 replaces 1/2" SAE Flat Washer F05011-2 to provide larger clamping area during adjustment (12/09). Flat Washer F05011-2 replaced F05011-90 .5" x 1.63" Serrated Washer supplied prior to Rev. H8.01. Serrated Washer no longer required with current side support mount arrangement.

³ Roller Kit 016562 replaces kit 015109 supplied prior to Rev. H8.00. Carriage bolt supplied to replace bed rail mounting bolt to allow clearance for side support roller hardware when side support is adjusted down.

⁴ Additional 5/8" SAE Flat Washer F05011-5 may be required on each side of side support to provide clearance for optional stainless steel side support guards. Extra washers are included in the stainless steel guard retrofit kit (016798).

⁵ Longer bolt replaces 3 1/2" F05009-93 used before 3/07.

⁶ Replaces F05010-4 Hex Lock Nut used prior to 9/06 for ease of assembly.

⁷ Stainless Steel Guards added. Guards prevent staining of lumber and reduce wear to side support. Guard revised with thicker steel and second mounting hole (LT30HD Rev. J5.00 & LT40HD Rev. J6.00).

8.7 Log Side Support Assembly (Manual)

[See Section 10.12](#) for hydraulic side supports

LT30HD
LT40HD

Rev. G1.00 - H7.00
Rev. G1.00 - H7.00

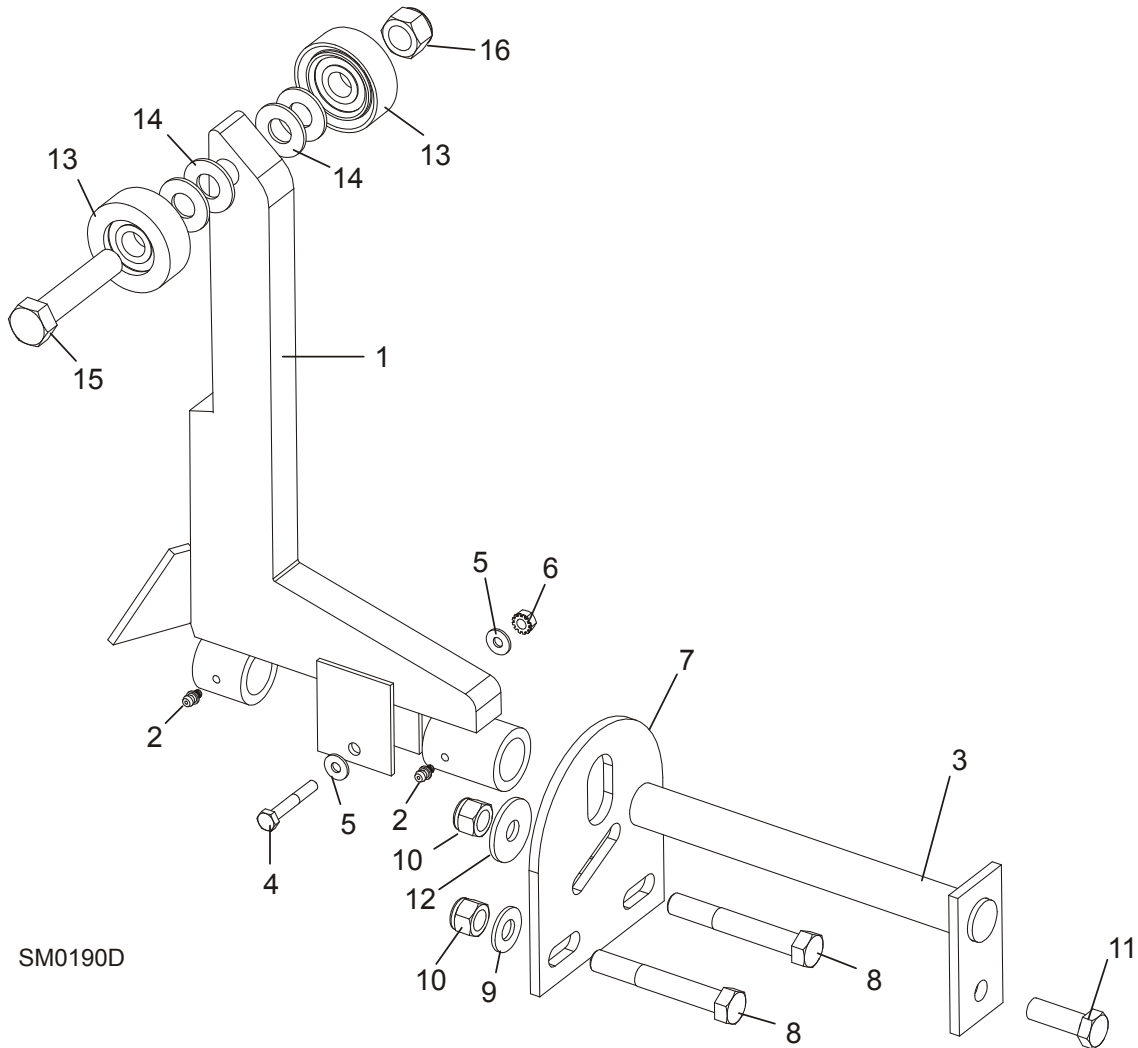

REF	DESCRIPTION (◆ Indicates Parts Available In Assemblies Only)	PART #	QTY.
1	SUPPORT, LOG SIDE	015235 ¹	2
2	Fitting, 3/16" Grease	P04107	2
	MOUNTING KIT, LOG SIDE SUPPORT	K09440 ²	2
3	Pin, Log Side Support Pivot	W09238	1
4	Bolt, 1/4-20 X 1 1/2" Hex Head Grade 5	F05005-4	1
5	Washer, 1/4" SAE Flat	F05011-11	2
6	Nut, 1/4-20 Self Locking	F05010-9	1

8

Bed Frame Assembly*Log Side Support Assembly (Manual)*

7	Plate, Log Side Support End	S09148	1	
8	Bolt, 1/2-13 X 3 1/2" Hex Head	F05008-61	2	
9	Washer, 1/2" SAE Flat	F05011-2	4	
10	Nut, 1/2-13 Hex Nylon Lock	F05010-8	3	
11	Bolt, 1/2-13 X 1 1/2" Hex Head	F05008-33	1	
12	WASHER, .5" X 1.63" SERRATED	F05011-90 ³	1	
	ROLLER KIT, SIDE SUPPORT (OPTIONAL)	015109 ⁴	4	◆
13	Roller Assembly, Side Support	015014	2	◆
14	Washer, 5/8" SAE Flat	F05011-5	4	
15	Bolt, 5/8-11 x 3" Hex Head Grade 5	F05009-37	1	
16	Nut, 5/8-11 Nylon Lock	F05010-34	1	
	Instruction Sheet, Side Support Roller	015109-526	1	◆

¹ Revised for added strength Rev. G6.00 and later.

² Upgrade mounting kit 016559 also available. Replaces Pin Weldment and Mounting Plate to new design to improve stability of side support adjustment ([See Section 8.6](#)).

³ Replaces 014632 provided prior to Rev. H6.00. Serrated washer helps maintain side support adjustment. Also replaces S09225 1/2" I.D. X 1 1/2" O.D. X .1196" Washer (12/97).

⁴ Roller kit replaced by new kit 016562 ([See Section 8.6](#)).

8.8 Safety Chain Assembly

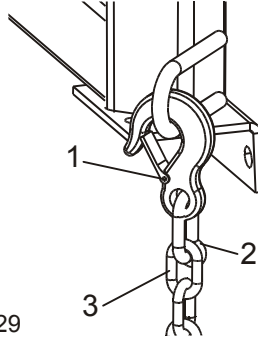

REF	DESCRIPTION (◆ Indicates Parts Available In Assemblies Only)	PART #	QTY.	
	CHAIN ASSEMBLY, TIE DOWN	A04376	1	
1	Hook, 5/8" Safety Chain	P12075	1	◆
2	Cold Shut, 3/8" Plain	P04772-2	1	◆
3	Chain, 5/16" Unplated	R02111	.938 ft.	◆

8 **Bed Frame Assembly**
Saw Head Rest Pin Assembly

8.9 Saw Head Rest Pin Assembly

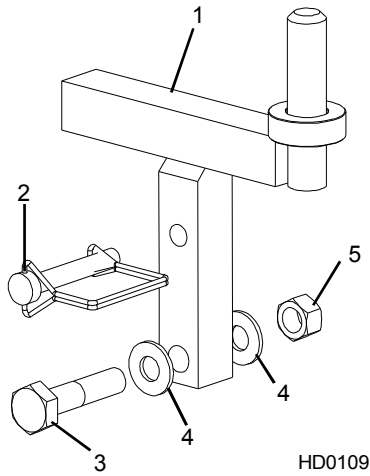

REF	DESCRIPTION (◆ Indicates Parts Available In Assemblies Only)	PART #	QTY.	
1	PIN, SAW HEAD REST	014102	1	
2	PIN, 3/8" X 2 1/4" SNAP RETAINER	014151	1	
3	BOLT, 1/2-13 X 2 1/4" HEX HEAD GRADE 5	F05008-10	1	
4	WASHER, 1/2" SAE FLAT	F05011-2	2	
5	NUT, 1/2-13 HEX LOCK	F05010-3	1	

8.10 Bed Frame Decals

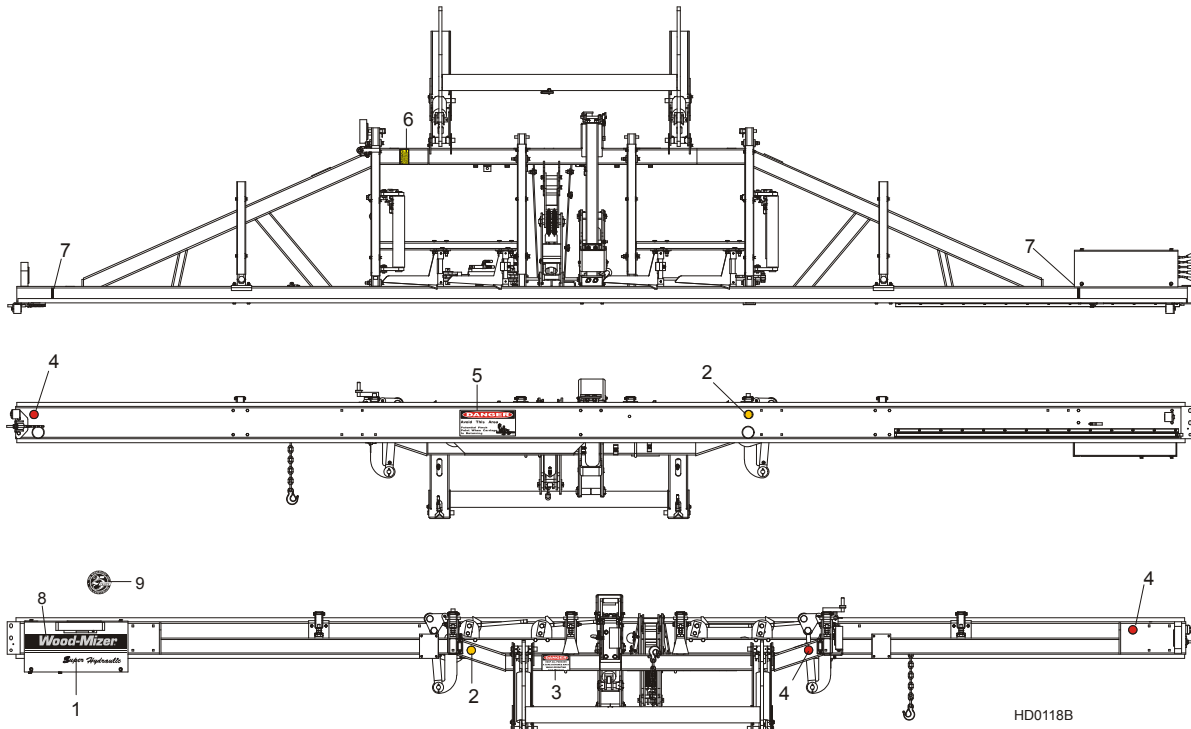

REF	DESCRIPTION (◆ Indicates Parts Available In Assemblies Only)	PART #	QTY.
1	DECAL, WOOD-MIZER HYDRAULIC LOGO	S12573	1
2	DECAL, AMBER REFLECTIVE 2" ROUND	P07453	2
3	DECAL, KEEP AWAY DANGER	S09851	1
4	DECAL, RED REFLECTIVE 2" ROUND	P07452	3
5	DECAL, PINCH POINT DANGER	P10287	1
6	DECAL, SAW HEAD REST CAUTION	S12581	1
7	DECAL, LOG LIMIT STRIPE	S12051	2

SECTION 9 MISCELLANEOUS

9.1 Replacement Manuals

REF	DESCRIPTION (◆ Indicates Parts Available In Assemblies Only)	PART #	QTY.
Wood-Mizer Product Information			
1	ALL-PRODUCTS CATALOG	PS750	1
Basic Sawmill Manuals			
2	TRU-SHARP BLADE HANDBOOK	M600	1
3	WOOD-MIZER GENERAL INFORMATION	M601	1
4	LT30HD/LT40HD OPERATOR'S MANUAL	M759	1
5	LT30HD/40HD PARTS MANUAL	M760	1
Power Option Manuals			
6	G24 ENGINE OPTION MANUAL	M768	1
7	ONAN P218/P220/P224 ENGINE SERVICE MANUAL	P12163	1
8	ONAN P224 ENGINE PARTS MANUAL	P12162	1
9	G25 ENGINE OPTION MANUAL	M825	1
10	G28 ENGINE OPTION MANUAL	M1159	1
11	KOHLER CH25 OWNER'S MANUAL	015993	1
12	KOHLER CH25 SERVICE MANUAL	015994	1
13	D33 ENGINE OPTION MANUAL	M915	1
14	D30 ENGINE OPTION MANUAL	M774	1
15	LOMBARDINI DIESEL ENGINE WORKSHOP MANUAL	014282	1
16	KUBOTA OPERATOR'S MANUAL	028555	1
17	KUBOTA SERVICE MANUAL	028566	1
18	KUBOTA PARTS MANUAL (1505B)	028564	1
19	G36 ENGINE OPTION MANUAL	M974	1
20	NISSAN ENGINE SERVICE MANUAL		1
21	NISSAN ENGINE PARTS MANUAL		1
Trailer Option Manuals			
22	ELECTRIC BRAKE TRAILER OPTION	M796	1
23	SURGE BRAKE TRAILER OPTION	M794	1
24	SUPER ELECTRIC BRAKE TRAILER OPTION	M797	1
25	SUPER SURGE BRAKE TRAILER OPTION	M795	1
Miscellaneous Option Manuals			
26	SHINGLE/LAPSIDER OPTION MANUAL	M621	1
27	OPERATOR'S SEAT OPTION MANUAL	M613	1
28	RESAW ATTACHMENT OPTION MANUAL	M263	1
29	BED EXTENSION OPTION MANUAL	M294	1
30	MKI DEBARKER ATTACHMENT OPTION MANUAL	M545	1
31	MKII DEBARKER ATTACHMENT OPTION MANUAL	M546	1
32	ACCUSET OPTION MANUAL	M987	1

33	NETWORKS OPTION MANUAL	M711	1
34	LASER SIGHT OPTION MANUAL	M679	1
35	AUTOCLUTCH OPTION MANUAL	M549	1
36	LUBE-MIZER OPTION MANUAL	M885	1
Electrical Diagrams			
37	G25 ELECTRICAL INFORMATION	M865	1
38	G28 ELECTRICAL INFORMATION	M1154	1
39	G36 ELECTRICAL INFORMATION	M977	1
40	D33 ELECTRICAL INFORMATION	M918	1
41	D30 ELECTRICAL INFORMATION	M864	1
42	D51 ELECTRICAL INFORMATION	M1164	1

SECTION 10 HYDRAULIC SYSTEM

10.1 Hydraulic Hoses

LT30HD
LT40HD

Rev. G6.00 - J7.00
Rev. G6.00 - J8.00

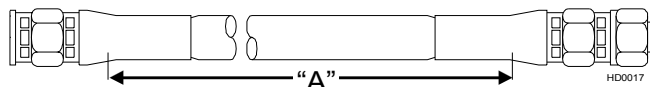

REF	COLOR	LENGTH "A"		DESCRIPTION	PART #	QTY.
		MFG SPEC	ACTUAL PART			
H1	None	9"	9"	1/4" HYDRAULIC PUMP TO VALVE	014437 ¹	1
	None	9"	9"	3/8" HYDRAULIC PUMP TO VALVE	014716 ¹	1
H2	Plain	27"	27"	LOG TURNER BASE	P12535 ²	1
H3	Orange	18"	18"	LOG TURNER TOP	015704	1
H4	Yellow	95"	95"	FRONT TOE BOARD TOP (LT30HD)	P12540 ³	1
		117"	117"	FRONT TOE BOARD TOP (LT40HD)	P12542 ³	1
H5	Gray	95"	95"	FRONT TOE BOARD BASE (LT30HD)	P12540 ³	1
		117"	117"	FRONT TOE BOARD BASE (LT40HD)	P12542 ³	1
H6	Pink	159"	159"	SIDE SUPPORT BASE (LT30HD)	P12547	1
		181"	181"	SIDE SUPPORT BASE (LT40HD)	014788	1
H7	Plain	159"	159"	SIDE SUPPORT TOP (LT30HD)	P12547	1
		181"	181"	SIDE SUPPORT TOP (LT40HD)	014788	1
H8	White	133"	135"	CLAMP IN/OUT TOP (LT30HD)	P12543	1
		155"	157"	CLAMP IN/OUT TOP (LT40HD)	P12546	1
H9	Dark Orange	125"	125"	CLAMP IN/OUT BASE (LT30HD)	014784	1
		147"	151"	CLAMP IN/OUT BASE (LT40HD)	P12545	1
H10	Purple	197"	196"	REAR TOE BOARD TOP (LT30HD)	014791	1
		219"	219"	REAR TOE BOARD TOP (LT40HD)	018026	1
H11	Black	197"	196"	REAR TOE BOARD BASE (LT30HD)	014791	1
		219"	219"	REAR TOE BOARD BASE (LT40HD)	018026	1
H12	Green	62"	62"	LOADING ARM BRANCH TOP	018020	2
H13	Yellow	64"	64"	LOADING ARM BRANCH BASE	018021	2
H14	Blue	164"	164"	LOADING ARM TOP (LT30HD)	P12548	1
		186"	186"	LOADING ARM TOP (LT40HD)	P12550	1
H15	Red	164"	164"	LOADING ARM BOTTOM (LT30HD)	P12548	1
		186"	186"	LOADING ARM BOTTOM (LT40HD)	P12550	1
H16	Green	182"	181"	1/4" CLAMP UP/DOWN TOP (LT30HD)	014788	1
		204"	204"	1/4" CLAMP UP/DOWN TOP (LT40HD)	014792	1
H17	Yellow	171"	173"	1/4" CLAMP UP/DOWN BASE (LT30HD)	P12549	1
		193"	194"	1/4" CLAMP UP/DOWN BASE (LT40HD)	015692	1

				GROMMET, 2 1/2" DIAMETER RUBBER	085614 ⁴	2
				GROMMET, 1 X 1 3/4" OVAL RUBBER	085613 ⁴	2

¹ Use 014437 (1/4" hose with (2) P09132 fittings) on Rev. G6.03+. Replaces 016058 (duplicate parts). Use 014716 (3/8" hose with (2) P12908 fittings) on Rev. G1-G6.02.

² Replaces P12533 14" hose originally supplied prior to Rev. H5.00. Longer hose and elbow fitting P09142 at side support cylinder base used to eliminate kinking of hose.

³ Front toe board hoses lengthened 4" for easier installation (7/98).

⁴ Added Rev. H1.00.

10 Hydraulic System

Hydraulic Hoses

10.2 Hydraulic Hoses

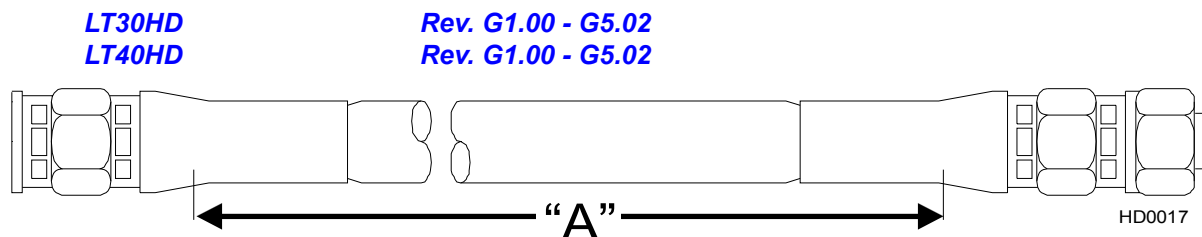

COLOR	LENGTH "A"	DESCRIPTION (◆ Indicates Parts Available In Assemblies Only)	PART #	QTY.	
None	9"	3/8" HYDRAULIC PUMP TO VALVE	014716	1	
Plain	27"	LOG TURNER BASE	P12535 ¹	1	
Orange	27"	LOG TURNER TOP	P12535	1	
Yellow	95"	FRONT TOE BOARD TOP (LT30HD)	P12540 ²	1	
	117"	FRONT TOE BOARD TOP (LT40HD)	P12542 ²	1	
Gray	95"	FRONT TOE BOARD BASE (LT30HD)	P12540 ²	1	
	117"	FRONT TOE BOARD BASE (LT40HD)	P12542 ²	1	
Plain	167"	SIDE SUPPORT TOP (LT30HD)	014786	1	
	189"	SIDE SUPPORT TOP (LT40HD)	014790	1	
Pink	159"	SIDE SUPPORT BASE (LT30HD)	P12547	1	
	181"	SIDE SUPPORT BASE (LT40HD)	014788	1	
White	142"	CLAMP TOP (LT30HD)	P12544	1	
	164"	CLAMP TOP (LT40HD)	P12548	1	
Dark Orange	135"	CLAMP BASE (LT30HD)	P12543	1	
	157"	CLAMP BASE (LT40HD)	P12546	1	
Purple	194"	REAR TOE BOARD TOP (LT30HD)	015692	1	
	216"	REAR TOE BOARD TOP (LT40HD)	014793	1	
Black	194"	REAR TOE BOARD BASE (LT30HD)	015692	1	
	216"	REAR TOE BOARD BASE (LT40HD)	014793	1	
Green	58"	LOADING ARM BRANCH TOP	014781 ³	2	
Yellow	61"	LOADING ARM BRANCH BASE	014782 ³	2	
Blue	163"	LOADING ARM TOP (LT30HD)	014785	1	
	185"	LOADING ARM TOP (LT40HD)	014789	1	
Red	163"	LOADING ARM BOTTOM (LT30HD)	014785	1	
	185"	LOADING ARM BOTTOM (LT40HD)	014789	1	

¹ Replaces P12533 14" hose originally supplied. Longer hose and elbow fitting P09142 at side support cylinder base used to eliminate kinking of hose.

² Front toe board hoses lengthened 4" for easier installation (7/98).

³ Loading arm hoses lengthened 4" for easier installation (3/00).

10.3 Hydraulic Control Box

LT30HD
LT40HD

Rev. G6.00 - J7.00
Rev. G6.00 - J8.00

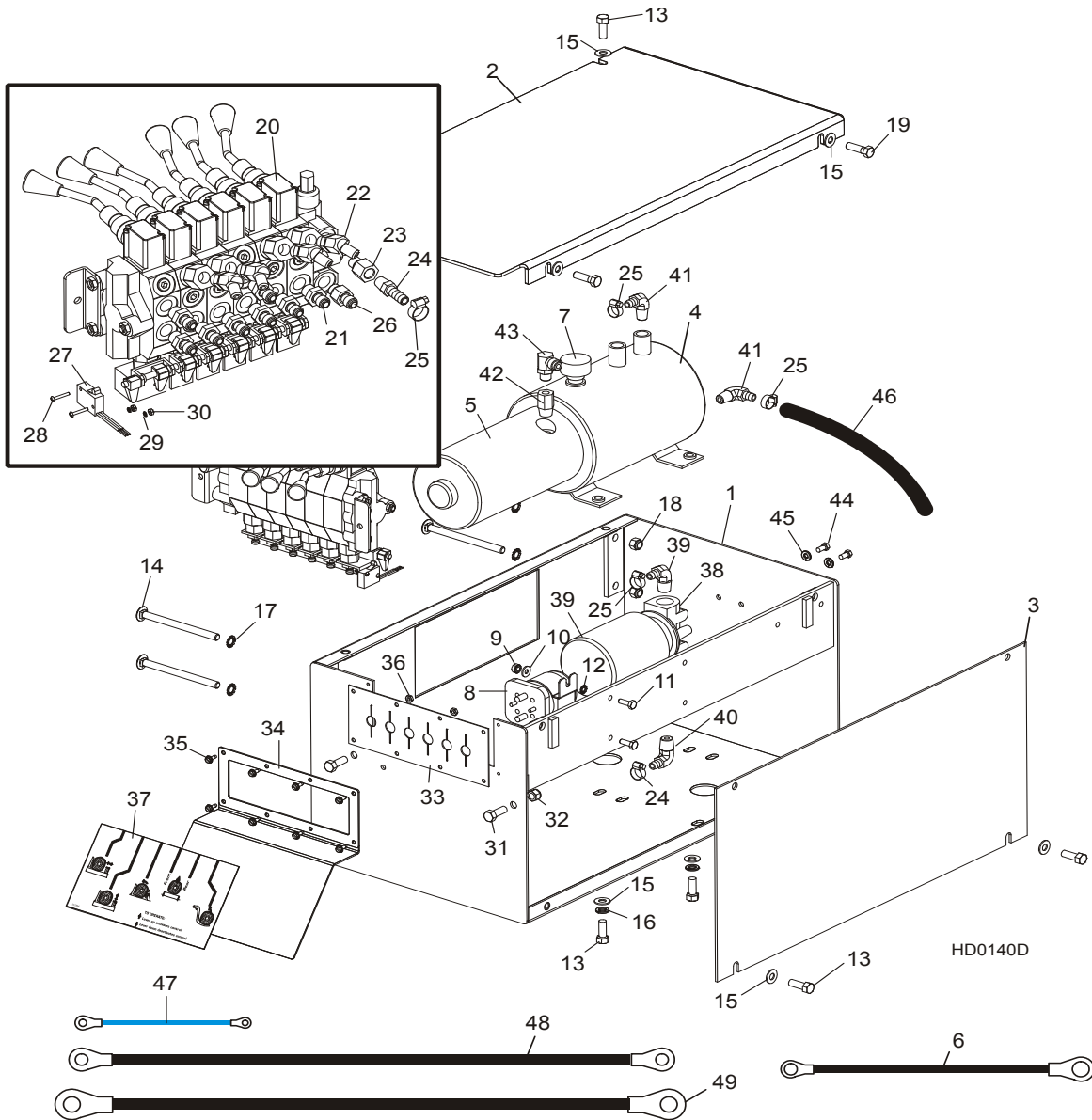

REF	DESCRIPTION (◆ Indicates Parts Available In Assemblies Only)	PART #	QTY.
1	BOX WELDMENT, SUPER HYDRAULIC PUMP HOUSING	015027	1
2	COVER, SUPER HYDRAULIC PUMP HOUSING TOP	015228	1
3	COVER, SUPER HYDRAULIC PUMP HOUSING SIDE	015227	1
4	PUMP KIT, HYDRAULIC W/MOTOR	061764 ¹	1

10

Hydraulic System Hydraulic Control Box

	Pump, Hydraulic Replacement Monarch Model #12070	016199	1	
	Motor Kit, Hydraulic Replacement	052807	1	
5	Motor, 12 VDC Hydraulic Pump #08714 (Iskra)	038683 ²	1	◆
	Brush Kit, 4-Valve Hydraulic Pump Motor #08658-I (Iskra)	038682 ²	1	
	Brush Kit, 4-Valve Hydraulic Pump Motor #08658	P09585 ²	1	◆
	Bearing, Base Motor #02318	P12513	1	
6	Wire Assembly, Motor Brush Ground	052806 ³	1	
7	Cap, Hydraulic Pump Vented Fill #03171	P12817	1	
	O-Ring, Hydraulic Pump/Reservoir #02352	P10198	1	
	Seal, Hydraulic Pump/Motor #02330	P10315	1	
8	SOLENOID KIT, 200A 12V SPST HYDRAULIC PUMP MOTOR	016371 ⁴	1	
	Solenoid, 200A 12V SPST Cont. Duty	015470	1	◆
	Diode Assembly, Solenoid Coil Chassis Gnd	015426 ⁵	1	
9	NUT, 1/4-20 SELF-LOCKING HEX	F05010-9	2	
10	WASHER, 1/4" SAE FLAT	F05011-11	2	
11	BOLT, #1/4-20 X 3/4" HEX HEAD FULL THREAD	F05005-1	2	
12	WASHER, 1/4" EXTERIOR STAR LOCK	F05011-37	2	
	FLUID, 1-QUART DEXRON III HYDRAULIC	P12742	2 1/4 gal.	
	FLUID, 1-GALLON CONOCO MV32 HYDRAULIC	006397 ⁶	2 1/4 gal.	
	FLUID, 1-GALLON EXXON UNIVIS HVI 13 ⁷ HYDRAULIC	P12822	2 1/4 gal.	
13	BOLT, 3/8-16 X 1" HEX HEAD GRADE 5	F05007-87 ⁸	8	
14	BOLT, 3/8-16 X 5" CARRIAGE HEAD	F05007-113	4	
15	WASHER, 3/8" SAE FLAT	F05011-3	10	
16	WASHER, 3/8" SPLIT LOCK	F05011-4	4	
17	WASHER, 3/8" EXTERNAL STAR LOCK	F05011-36	4	
18	NUT, 3/8-16 HEX NYLON LOCK	F05010-10	4	
19	BOLT, 3/8-16 X 1 1/4" HEX HEAD	F05007-2	2	
20	VALVE, HYDRAULIC 6 SECTION (See Form 575 For Valve Service Parts)	015260 ⁹	1	
21	FITTING, 3/8" O-RING - 1/4" JIC	P26284 ⁹	8	
22	FITTING, #6 SAE - 1/4" JIC 45° ELBOW	015488 ⁹	4	
23	FITTING, #6 SAE MALE - 1/4" NPT FEMALE	014686 ⁹	1	
24	FITTING, 1/4" NPT X 3/8" HOSE BARB	014685 ⁹	1	
25	CLAMP, 11/16" HOSE	P12739	5	
26	FITTING, 3/8" O-RING - 1/4" JIC	P26284 ¹⁰	1	
	FITTING, 3/8" O-RING - 3/8" JIC	014687 ¹⁰	1	
27	SWITCH, HYDRAULIC VALVE ELECTRIC	024198	1	
28	SCREW, #4-40 X 3/4" SLOTTED	F05004-13	2	
29	WASHER, #4 SPLIT LOCK	F05011-21	2	
30	NUT, #4-40 HEX	F05010-43	2	
31	BOLT, 3/8-16 X 1" HEX HEAD	F05007-7	2	
32	NUT, 3/8-16 HEX NYLON LOCK	F05010-10	2	

33	SEAL, RUBBER VALVE HANDLE	015079 ⁹	1	
34	PLATE, VALVE HANDLE DECAL	015078 ⁹	1	
35	SCREW, #10-24 X 1/2 SLOTTED HEX SELF-TAPPING	F05015-7	8	
36	NUT, #10-24 SELF-LOCKING HEX	F05010-14	2	
37	DECAL, 1997 HYDRAULIC CONTROL BOX	015364 ⁹	1	
38	MANIFOLD, HYDRAULIC CARTRIDGE FILTER	P22683	1	
39	Filter, S28 Hydraulic Cartridge	P20301	1	
40	FITTING, #6-8 (1/2" NPT) - 3/8" HOSE BARB ELBOW	P12707 ⁹	2	
41	FITTING, #6-6 (3/8" NPT) - 3/8" HOSE BARB ELBOW	P12708 ⁹	2	
42	FITTING, 3/8" NPT MALE - 1/4" NPT FEMALE	015490 ¹⁰	1	
	FITTING, 3/8" NPT MALE - #6 FEMALE	P12723 ¹⁰	1	
43	FITTING, 1/4" NPT - 1/4" JIC ELBOW	P09142 ¹⁰	1	
	FITTING, #6 SAE - 3/8" JIC ELBOW	P12704 ¹⁰	1	
44	BOLT, 1/4-20 X 1/2" HEX HEAD	F05005-15	2	
45	WASHER, 1/4" SPLIT LOCK	F05011-14	2	
46	HOSE, 3/8" LOW PRESSURE HYDRAULIC	R01892-1	A/R	
47	WIRE ASSEMBLY, 14 GA X 4" #10 & 5/16" RINGS	036315	1	
48	CABLE ASSEMBLY, 1 GA X 16" HYDRAULIC PUMP TO SOLENOID	036310	1	
49	CABLE ASSEMBLY, 1 GA X 16" HYDRAULIC PUMP GROUND	036312	1	
	WASHER, 3/8" STAR EXTERNAL	F05011-36	2	

¹ Pump Kit 061764 replaces Pump P12701 1/09. Kit includes P12701 plus Brush Ground Wire Kit 052805 to insure adequate ground connection.

² Bosch motor P09955 replaced by vendor with Iskra motor 1/06. Brush kit P09585 no longer available to service Bosch motor. Replace motor using kit 052807. Use Brush Kit 038682 to service Iskra motor.

³ Brush Ground Wire 052806 added 7/06 to improve ground connection. Kit 052805 to be supplied to all customers who purchased sawmills with Iskra pump motors after 1/06. Kit includes wire, hardware and instructions.

⁴ Solenoid Kit 016371 replaces Solenoid 015470. Kit includes solenoid and replacement instructions.

⁵ Diode Assembly 015426 added to prevent damage to hydraulic microswitch (8/04).

⁶ Conoco MV32 Fluid 006397 replaces Univis HVI 26 Fluid P12823 (formerly named J26) used prior to 1/08. Fluids are interchangeable.

⁷ Formerly named J13.

⁸ F05007-87 Grade 5 bolt replaces F05007-7 bolt supplied before 5/03.

⁹ 6-Section valve replaces 5-Section valve to allow operation of two-plane clamp on Rev G6.00+. Requires different fittings, handle seal, plate, and decal. [See Section 10.4](#) or [Section 10.5](#) for previous 5-Section valves.

¹⁰ Use 1/4" fittings P26284, 015490, and P09142 for Rev. G6.03+. Use 3/8" fittings 014687, P12723, and P12704 on Rev. G6-G6.02.

10.4 Hydraulic Control Box

LT30HD
LT40HD

Rev. G4.00 - G5.02
Rev. G4.00 - G5.02

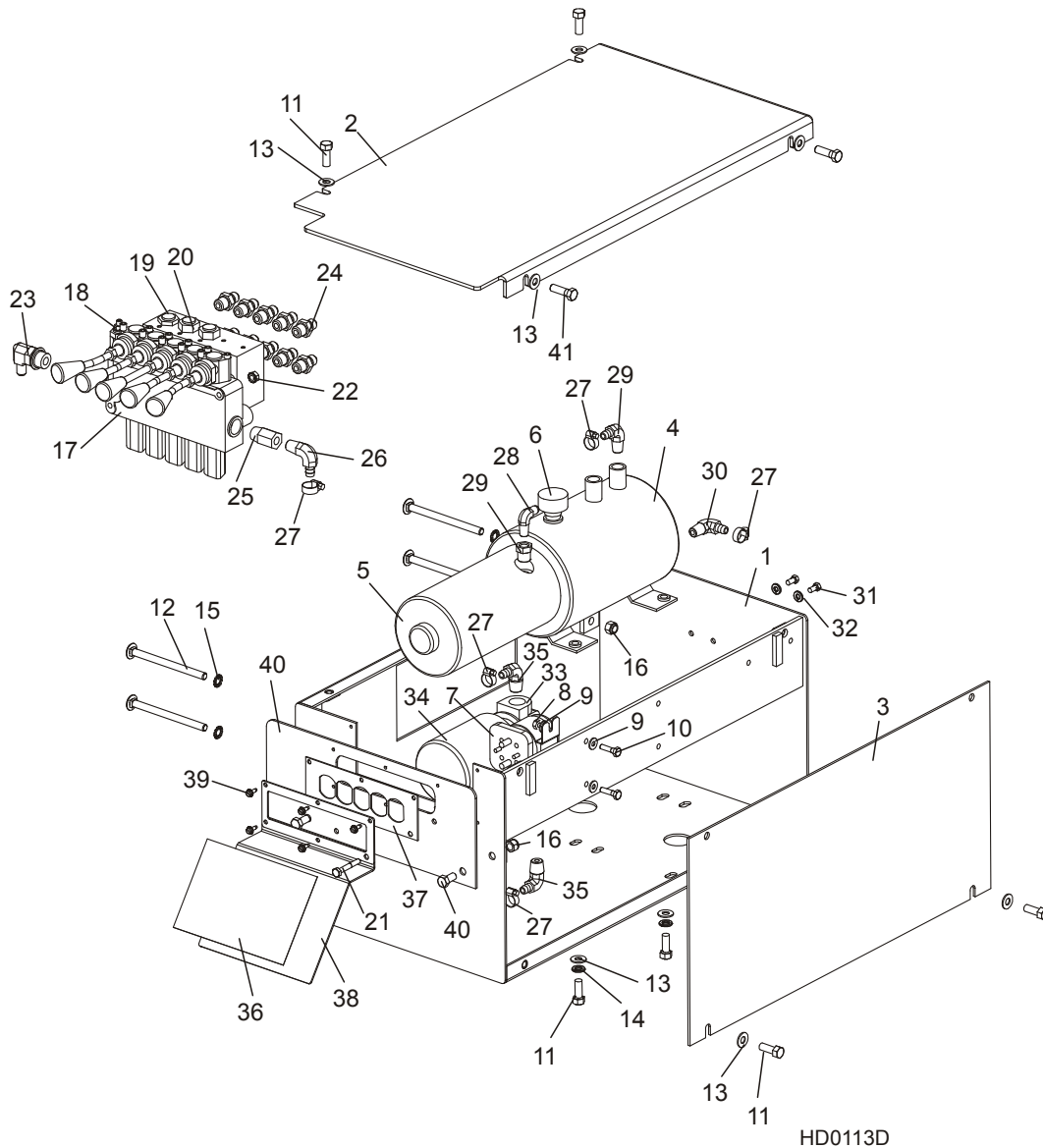

REF	DESCRIPTION (◆ Indicates Parts Available In Assemblies Only)	PART #	QTY.
1	BOX WELDMENT, SUPER HYDRAULIC PUMP HOUSING	015027 ¹	1
2	COVER, SUPER HYDRAULIC PUMP HOUSING TOP	015228 ¹	1
3	COVER, SUPER HYDRAULIC PUMP HOUSING SIDE	015227 ¹	1
4	PUMP KIT, HYDRAULIC W/MOTOR	061764 ²	1
	Pump, Hydraulic Replacement Monarch Model #12070	016199	1
	Motor Kit, Hydraulic Replacement	052807	1

5	Motor, 12 VDC Hydraulic Pump #08714 (Iskra)	038683 ³	1	◆
	Brush Kit, 4-Valve Hydraulic Pump Motor #08658-I (Iskra)	038682 ³	1	
	Brush Kit, 4-Valve Hydraulic Pump Motor #08658	P09585 ³	1	◆
	Bearing, Base Motor #02318	P12513	1	
	Wire Assembly, Motor Brush Ground	052806 ⁴	1	
6	Cap, Hydraulic Pump Vented Fill #03171	P12817	1	
	O-Ring, Hydraulic Pump/Reservoir #02352	P10198	1	
	Seal, Hydraulic Pump/Motor #02330	P10315	1	
7	SOLENOID KIT, 200A 12V SPST HYDRAULIC PUMP MOTOR	016371 ⁵	1	
	Solenoid, 200A 12V SPST Cont. Duty	015470	1	◆
	Diode Assembly, Solenoid Coil Chassis Gnd	015426 ⁶	1	
8	NUT, 1/4-20 SELF-LOCKING HEX	F05010-9	2	
9	WASHER, 1/4" SAE FLAT	F05011-11	4	
10	BOLT, #1/4-20 X 1" HEX HEAD	F05005-38	2	
	FLUID, 1-QUART DEXRON III HYDRAULIC	P12742	2 1/4 gal.	
	FLUID, 1-GALLON CONOCO MV32 HYDRAULIC	006397 ⁷	2 1/4 gal.	
	FLUID, 1-GALLON EXXON UNIVIS HVI 13⁸ HYDRAULIC	P12822	2 1/4 gal.	
11	BOLT, 3/8-16 X 1" HEX HEAD GRADE 5	F05007-87	8	
12	BOLT, 3/8-16 X 5" CARRIAGE HEAD	F05007-113	4	
13	WASHER, 3/8" SAE FLAT	F05011-3	8	
14	WASHER, 3/8" SPLIT LOCK	F05011-4	4	
15	WASHER, 3/8" EXTERNAL STAR LOCK	F05011-36	4	
16	NUT, 3/8-16 HEX NYLON LOCK	F05010-10	6	
17	VALVE, HYDRAULIC 5-HANDLE SIDE-PORT	014218 ⁹	1	
	Handle Kit, Hydraulic 5-Handle Valve 07151	018040	1	
	Switch, Hydraulic Valve Electric	024198 ¹⁰	1	
	Operators, Spool	014218-1	1	
	Rack, Paddles	014218-3	1	
	Spring Kit, Centering w/Bolts	014218-4	1	
	Pin Kit, Paddle	014218-5	1	
	Paddle, Valve Operator	014218-6	1	
	Bracket, Micro Switch Mount	014218-7	1	
18	Valve, Main Relief 07184	014218-8	1	
	Valve Kit, Low-Pressure Check Replacement	014534	1	
19	Valve, Low-Pressure Check 07186	014533	1	◆
	Instruction Sheet, Check Valve Replacement	A12869-649	1	◆
	Valve Kit, High-Pressure Check Replacement	A12869	1	
20	Valve, High-Pressure Check 04282	P12844	2	◆
	Instruction Sheet, Check Valve Replacement	A12869-649	1	◆
21	BOLT, 1/4-20 X 1 3/4" HEX HEAD GRADE 2	F05005-4	2	
22	NUT, 1/4-20 SELF-LOCKING HEX	F05010-9	2	
	HOSE W/FITTINGS, 3/8" DIA. X 9" HYDRAULIC	014716	1	

23	FITTING, #6 JIC - #8 SAE ELBOW	015907 ⁹	1	
24	FITTING, 3/8" O-RING - 1/4" JIC	P26284	10	
25	FITTING, #8 SAE MALE - 3/8" NPT FEMALE	P12706 ⁹	1	
26	FITTING, 3/8" NPT - 3/8" BARB ELBOW	P12708 ⁹	1	
27	CLAMP, 11/16" HOSE	P12739	4	
28	FITTING, #6 SAE - 3/8" JIC ELBOW	P12704	1	
29	FITTING, #6 SAE - #6 NPT ADAPTOR	P12723	1	
30	FITTING, #6-6 (3/8" NPT) - 3/8" HOSE BARB ELBOW	P12708	2	
31	BOLT, 1/4-20 X 1/2" HEX HEAD	F05005-15	2	
32	WASHER, 1/4" SPLIT LOCK	F05011-14	2	
33	MANIFOLD, HYDRAULIC CARTRIDGE FILTER	P22683	1	
34	Filter, S28 Hydraulic Cartridge	P20301	1	
35	FITTING, #6-8 (1/2" NPT) - 3/8" HOSE BARB ELBOW	P12707	2	
36	DECAL, 1997 HYDRAULIC CONTROL BOX	015363	1	
	HOSE, 3/8" LOW PRESSURE HYDRAULIC	R01892-1	A/R	
37	SEAL, RUBBER VALVE HANDLE	015082	1	
38	PLATE, VALVE HANDLE DECAL	015081	1	
39	SCREW, #10-24 X 1/2 SLOTTED HEX SELF-TAPPING	F05015-7	5	
40	PLATE, HYDRAULIC BOX ADAPTER	015915	1	
41	BOLT, 3/8-16 X 3/4" HEX HEAD	F05007-27	2	
42	BOLT, 3/8-16 X 1 1/4" HEX HEAD	F05007-2	2	

¹ 015027 larger hyd. control box replaces 015311 smaller version on all hyd. mills (Rev. G4.00-G5.02).

² Pump Kit 061764 replaces Pump P12701 1/09. Kit includes P12701 plus Brush Ground Wire Kit 052805 to insure adequate ground connection.

³ Bosch motor P09955 replaced by vendor with Iskra motor 1/06. Brush kit P09585 no longer available to service Bosch motor. Replace motor using kit 052807. Use Brush Kit 038682 to service Iskra motor.

⁴ Brush Ground Wire 052806 added 7/06 to improve ground connection. Kit 052805 to be supplied to all customers who purchased sawmills with Iskra pump motors after 1/06. Kit includes wire, hardware and instructions.

⁵ Solenoid Kit 016371 replaces Solenoid 015470. Kit includes solenoid and replacement instructions.

⁶ Diode Assembly 015426 added to prevent damage to hydraulic microswitch (8/04).

⁷ Conoco MV32 Fluid 006397 replaces Univas HVI 26 Fluid P12823 (formerly named J26) used prior to 1/08. Fluids are interchangeable.

⁸ Formerly named J13.

⁹ 014218 side-port valve replaces 014696 rear-port valve. Requires different fittings (Rev. G4.00-G5.02). [See Section 10.5](#) for rear-port valve.

¹⁰ Saleable service assembly created which includes 014765 3-wire switch and crimped terminals (7/97). 014765 3-wire switch directly replaces P12735 2-wire switch (4/97).

10.5 Hydraulic Control Box

LT30HD
LT40HD

Rev. G1.00 - G3.00
Rev. G1.00 - G3.00

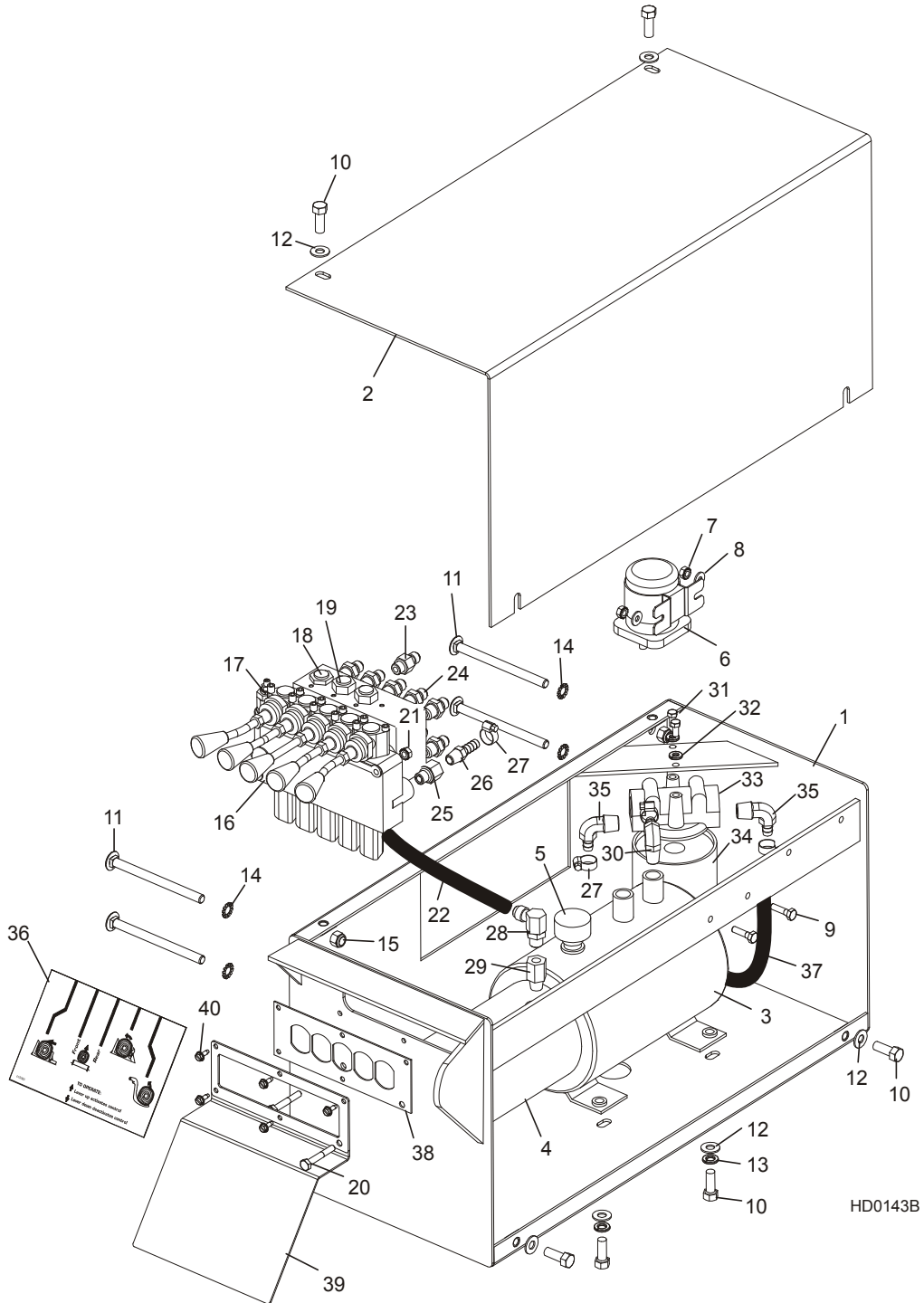

REF	DESCRIPTION (◆ Indicates Parts Available In Assemblies Only)	PART #	QTY.	
1	BOX WELDMENT, STANDARD HYDRAULIC PUMP HOUSING	015311	1	
2	COVER, STANDARD HYDRAULIC PUMP HOUSING	015313	1	
3	PUMP KIT, HYDRAULIC W/MOTOR	061764 ¹	1	
	Pump, Hydraulic Replacement Monarch Model #12070	016199	1	
	Motor Kit, Hydraulic Replacement	052807	1	
4	Motor, 12 VDC Hydraulic Pump #08714 (Iskra)	038683 ²	1	◆
	Brush Kit, 4-Valve Hydraulic Pump Motor #08658-I (Iskra)	038682 ²	1	
	Brush Kit, 4-Valve Hydraulic Pump Motor #08658	P09585 ²	1	◆
	Bearing, Base Motor #02318	P12513	1	
	Wire Assembly, Motor Brush Ground	052806 ³	1	
5	Cap, Hydraulic Pump Vented Fill #03171	P12817	1	
	O-Ring, Hydraulic Pump/Reservoir #02352	P10198	1	
	Seal, Hydraulic Pump/Motor #02330	P10315	1	
6	SOLENOID KIT, 200A 12V SPST HYDRAULIC PUMP MOTOR	016371 ⁴	1	
	Solenoid, 200A 12V SPST Cont. Duty	015470	1	◆
	Diode Assembly, Solenoid Coil Chassis Gnd	015426 ⁵	1	
7	NUT, 1/4-20 SELF-LOCKING HEX	F05010-9	2	
8	WASHER, 1/4" SAE FLAT	F05011-11	2	
9	BOLT, #1/4-20 X 1" HEX HEAD	F05005-38	2	
	FLUID, 1-QUART DEXRON III HYDRAULIC	P12742	2 1/4 gal.	
	FLUID, 1-GALLON CONOCO MV32 HYDRAULIC	006397 ⁶	2 1/4 gal.	
	FLUID, 1-GALLON EXXON UNIVIS HVI 13 ⁷ HYDRAULIC	P12822	2 1/4 gal.	
10	BOLT, 3/8-16 X 1" HEX HEAD GRADE 5	F05007-87	8	
11	BOLT, 3/8-16 X 5" CARRIAGE HEAD	F05007-113	4	
12	WASHER, 3/8" SAE FLAT	F05011-3	8	
13	WASHER, 3/8" SPLIT LOCK	F05011-4	4	
14	WASHER, 3/8" EXTERNAL STAR LOCK	F05011-36	4	
15	NUT, 3/8-16 HEX NYLON LOCK	F05010-10	4	
16	VALVE, HYDRAULIC 5-HANDLE REAR-PORT	014696	1	
	Handle Kit, Hydraulic 5-Handle Valve 07151	018040	1	
	Switch, Hydraulic Valve Electric	024198 ⁸	1	
	Operators, Spool	014218-1	1	
	Rack, Paddles	014218-3	1	
	Spring Kit, Centering w/Bolts	014218-4	1	
	Pin Kit, Paddle	014218-5	1	
	Paddle, Valve Operator	014218-6	1	
	Bracket, Micro Switch Mount	014218-7	1	
17	Valve, Main Relief 07184	014218-8	1	
	Valve Kit, Low-Pressure Check Replacement	014534	1	
18	Valve, Low-Pressure Check 07186	014533	1	◆
	Instruction Sheet, Check Valve Replacement	A12869-649	1	◆

	Valve Kit, High-Pressure Check Replacement	A12869	1	
19	Valve, High-Pressure Check 04282	P12844	2	◆
	Instruction Sheet, Check Valve Replacement	A12869-649	1	◆
20	BOLT, 1/4-20 X 1 3/4" HEX HEAD GRADE 2	F05005-4	2	
21	NUT, 1/4-20 SELF-LOCKING HEX	F05010-9	2	
22	HOSE W/FITTINGS, 3/8" DIA. X 9" HYDRAULIC	014716	1	
23	FITTING, 3/8" O-RING - 3/8" JIC	014687	1	
24	FITTING, 3/8" O-RING - 1/4" JIC	P26284	10	
25	FITTING, #6 SAE MALE - 1/4" NPT FEMALE	014686	1	
26	FITTING, 1/4" NPT X 3/8" HOSE BARB	014685	1	
27	CLAMP, 11/16" HOSE	P12739	4	
28	FITTING, #6 SAE - 3/8" JIC ELBOW	P12704	1	
29	FITTING, #6 SAE - #6 NPT ADAPTOR	P12723	1	
30	FITTING, #6-6 (3/8" NPT) - 3/8" HOSE BARB ELBOW	P12708	1	
31	BOLT, 1/4-20 X 1/2" HEX HEAD	F05005-15	2	
32	WASHER, 1/4" SPLIT LOCK	F05011-14	2	
33	MANIFOLD, HYDRAULIC CARTRIDGE FILTER	P22683	1	
34	Filter, S28 Hydraulic Cartridge	P20301	1	
35	FITTING, #6-8 (1/2" NPT) - 3/8" HOSE BARB ELBOW	P12707	2	
36	DECAL, 1997 HYDRAULIC CONTROL BOX	015363	1	
37	HOSE, 3/8" LOW PRESSURE HYDRAULIC	R01892-1	A/R	
38	SEAL, RUBBER VALVE HANDLE	015082	1	
39	PLATE, VALVE HANDLE DECAL	015081	1	
40	SCREW, #10-24 X 1/2 SLOTTED HEX SELF-TAPPING	F05015-7	5	

¹ Pump Kit 061764 replaces Pump P12701 1/09. Kit includes P12701 plus Brush Ground Wire Kit 052805 to insure adequate ground connection.

² Bosch motor P09955 replaced by vendor with Iskra motor 1/06. Brush kit P09585 no longer available to service Bosch motor. Replace motor using kit 052807. Use Brush Kit 038682 to service Iskra motor.

³ Brush Ground Wire 052806 added 7/06 to improve ground connection. Kit 052805 to be supplied to all customers who purchased sawmills with Iskra pump motors after 1/06. Kit includes wire, hardware and instructions.

⁴ Solenoid Kit 016371 replaces Solenoid 015470. Kit includes solenoid and replacement instructions.

⁵ Diode Assembly 015426 added to prevent damage to hydraulic microswitch (8/04).

⁶ Conoco MV32 Fluid 006397 replaces Univis HVI 26 Fluid P12823 (formerly named J26) used prior to 1/08. Fluids are interchangeable.

⁷ Formerly named J13.

⁸ Saleable service assembly created which includes 014765 3-wire switch and crimped terminals (7/97). 014765 3-wire switch directly replaces P12735 2-wire switch (4/97).

10.6 Hydraulic Power Supply Strip

LT30HD
LT40HD

Rev. J2.00 - J7.00
Rev. J2.00 - J8.00

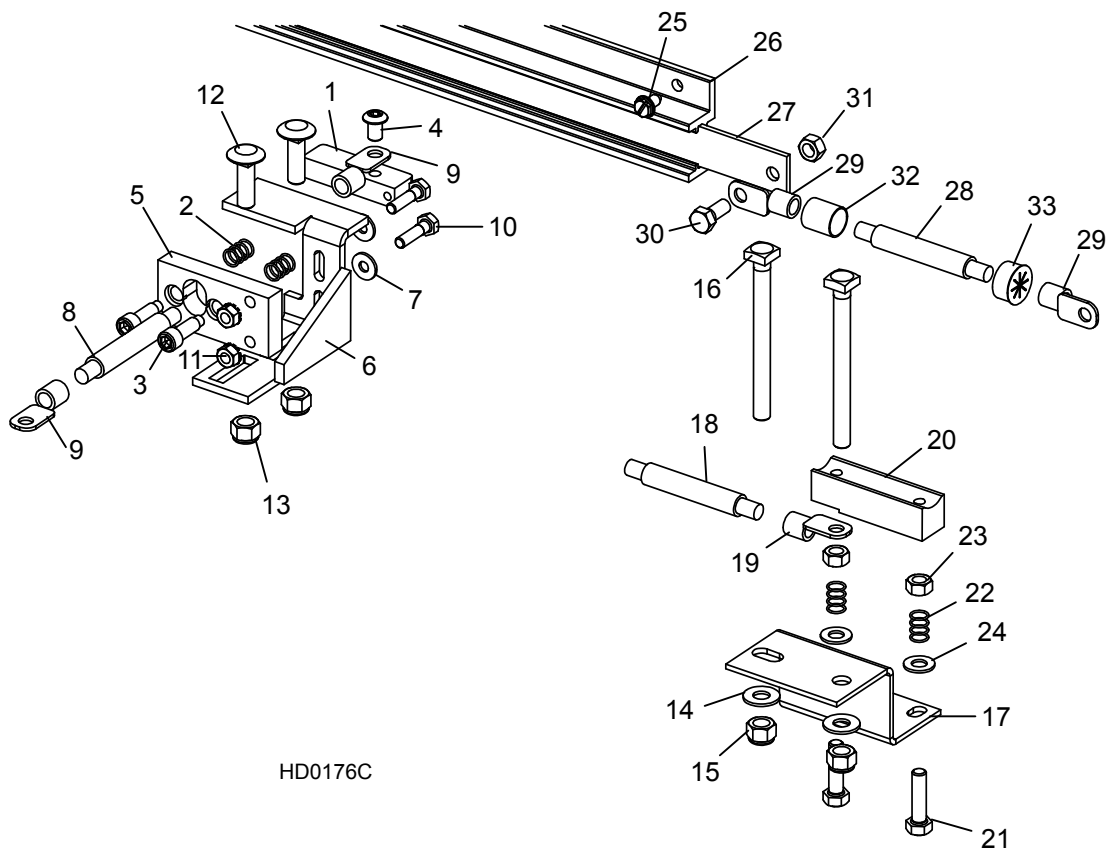

REF	DESCRIPTION (◆ Indicates Parts Available In Assemblies Only)	PART #	QTY.
	CONTACT ASSEMBLY, HYDRAULIC POWER SUPPLY (POSITIVE)	010103	1
	Contact Kit, Hydraulic Power Supply Positive	007716	1
1	Contact, Hydraulic Power Supply (Positive)	015253	1
2	Spring, Positive Contact	P10077	2
3	Bolt, 5/16" X 3/4" Shoulder (1/4-20 Thread) Stainless	F05006-143 ¹	2
4	Bolt, 5/16-18 x 1/2" Socket Button Head	F05006-20	1
5	Insulator, Positive Contact	S10072	1
6	Bracket, Positive Contact Mounting	015324	1
7	Washer, 1/4" SAE Flat	F05011-11	2
8	Cable, 1AWG SO Welding	R01971 ²	1.17
9	Terminal, 5/16" 1-2GA Ring NI Loose	F05092-16 ²	2
10	Bolt, 1/4-20 X 1" Hex Head Grade 2	F05005-38	2
11	Nut, 1/4-20 Hex Self-Locking	F05010-9	2

12	Bolt, 3/8-16 X 1 1/4" Carriage Head	F05007-11	2	
13	Nut, 3/8-16 Hex Nylon Lock	F05010-10	2	
	CONTACT KIT, HYDRAULIC POWER SUPPLY (GROUND)	010104	1	
14	Washer, 3/8" SAE Flat	F05011-3	2	
15	Nut, 3/8-16 Hex Nylon Lock	F05010-10	2	
16	Bolt, 3/8-16 X 4" Square Head	F05007-175 ³	2	
17	Bracket, Ground Contact Mounting	016792 ⁴	1	
	Cable Assy, Hydraulic Negative Contact (Ground) #1 Weld	036306	1	
18	Cable, #1 Weld	R01971	2.17 Ft	◆
19	Terminal, 5/16" Ring #2 Gauge	F05092-16	2	
	Contact Kit, Hydraulic Power Supply Ground	007717	1	
20	Contact, Hydraulic Power Supply (Ground)	015264 ⁵	1	◆
21	Bolt, 5/16-18 X 1 1/4" Hex Head Full Thread Grade 5	F05006-93	2	
22	Spring, Ground Contact	P10077	2	
23	Nut, 5/16-18 Hex	F05010-17	2	
24	Washer, 5/16" SAE Flat	F05011-17	2	
	STRIP ASSEMBLY, 6' HYDRAULIC POWER SUPPLY W/3 FT. CABLE	A11977	1	
25	Screw, 1/4-20 X 1/2" Slotted Hex Head	F05015-1	8	
26	Housing, 6' Contact Strip	P11976	1	
	Strip, 6' Contact With Cable	A12043-N	1	
27	Strip, 6' Contact	S10075	1	◆
28	Cable, #1 Weld	R01971	Ft	◆
29	Terminal, 5/16" Ring #2 Gauge	F05092-16	2	
30	Bolt, 5/16-18 X 3/4" Hex Head Black Nylon	F05006-45	1	
31	Nut, 5/16-18 Hex Black Nylon	F05010-86	1	
32	Tube, 5/8" Heat Shrink	R01950-5	.10 Ft	◆
33	Grommet, 5/8" Wire	P04137	1	

¹ Stainless Steel Bolt F05006-143 replaces F05006-44 to prevent corrosion (12/09).

² [See Section 5.10](#) for pre-assembled cable service assemblies.

³ Square head bolt F05007-175 replaces hex head bolt F05007-4 originally supplied prior to 3/01 for easier installation.

⁴ Ground Contact Mounting Bracket 016792 replaces 015265 originally supplied prior to Rev. J2.00. New bracket and mounting arrangement of contact improves ground contact with bottom track rail. Use kit 010104 to retrofit previous revisions.

⁵ 015264 not available for service. Use kit 007717.

10.7 Hydraulic Power Supply Strip

LT30HD
LT40HD

Rev. G1.00 - J1.00
Rev. G1.00 - J1.00

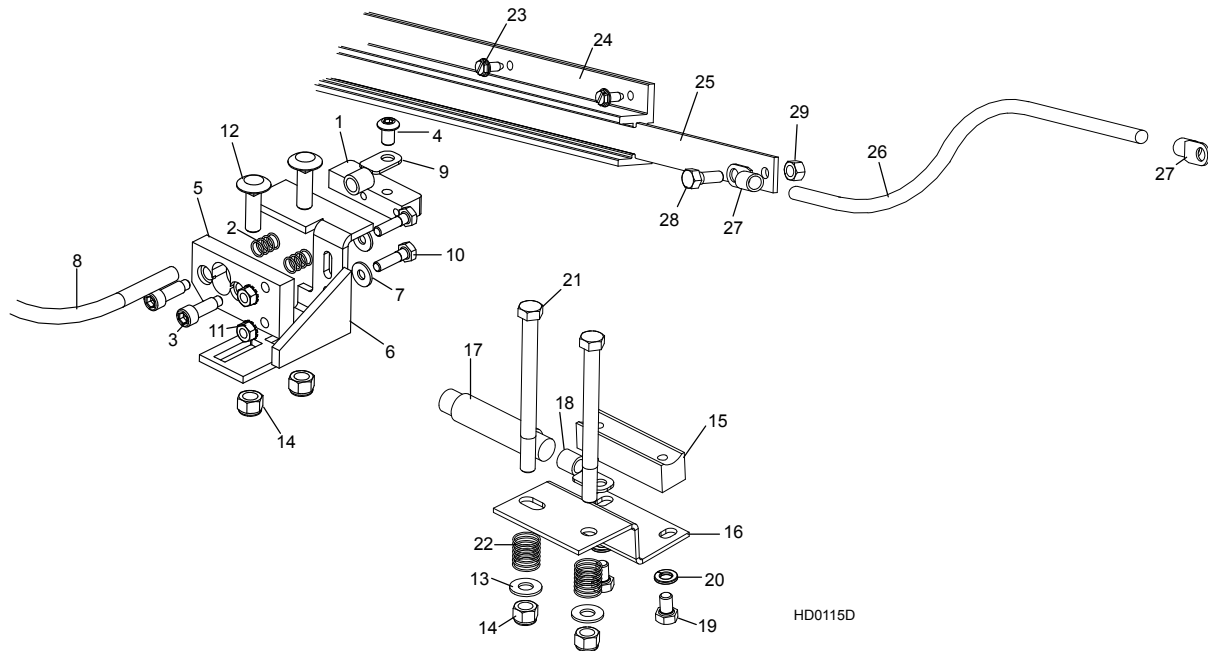

HD0115D

REF	DESCRIPTION (◆ Indicates Parts Available In Assemblies Only)	PART #	QTY.	
	CONTACT ASSEMBLY, HYDRAULIC POWER SUPPLY (POSITIVE)	010103	1	
	Contact Kit, Hydraulic Power Supply Positive	007716	1	
1	Contact, Hydraulic Power Supply (Positive)	015253	1	
2	Spring, Positive Contact	P10077	2	
3	Bolt, 5/16" X 3/4" Shoulder (1/4-20 Thread) Stainless	F05006-143 ¹	2	
4	Bolt, 5/16-18 x 1/2" Socket Button Head	F05006-20	1	
5	Insulator, Positive Contact	S10072	1	
6	Bracket, Positive Contact Mounting	015324	1	
7	Washer, 1/4" SAE Flat	F05011-11	2	
8	Cable Assy, Hydraulic Positive Contact	015885 ²	1	
	Cable, #1 Weld	R01971	2.5 Ft	◆
9	Terminal, 5/16" Ring #2 Gauge	F05092-16	2	
10	Bolt, 1/4-20 X 1" Hex Head Grade 2	F05005-38	2	
11	Nut, 1/4-20 Hex Self-Locking	F05010-9	2	
12	BOLT, 3/8-16 X 1 1/4" CARRIAGE HEAD	F05007-11	2	
13	WASHER, 3/8" SAE FLAT	F05011-3	2	
14	NUT, 3/8-16 HEX NYLON LOCK	F05010-10	4	
15	CONTACT, HYDRAULIC POWER SUPPLY (GROUND)	015264 ³	1	◆
16	BRACKET, GROUND CONTACT MOUNTING	015265 ⁴	1	

	CABLE ASSY, HYDRAULIC NEGATIVE CONTACT (GROUND) #1 WELD	024676 ⁵	1	
17	Cable, #1 Weld	R01971	2.17 Ft	◆
18	Terminal, 5/16" Ring #2 Gauge	F05092-16	1	
19	BOLT, 5/16-18 X 1/2" HEX HEAD GRADE 5	F05006-15 ⁴	2	
20	WASHER, 5/16" SPLIT LOCK	F05011-13 ⁴	2	
21	BOLT, 3/8-16 X 4 1/2" HEX HEAD GRADE 2	F05007-35 ⁴	2	
22	SPRING, GROUND CONTACT	P04282 ⁴	2	
23	SCREW, 1/4-20 X 1/2" SLOTTED HEX HEAD	F05015-1	8 ⁶	
	STRIP ASSEMBLY, 6' HYDRAULIC POWER SUPPLY W/3 FT. CABLE	A11977	1	
24	Housing, 6' Contact Strip	P11976	1	
	Strip, 6' Contact With Cable	A12043-N	1	
25	Strip, 6' Contact	S10075	1	◆
26	Cable, #1 Weld	R01971	3 Ft	◆
27	Terminal, 5/16" Ring #2 Gauge	F05092-16	2	
28	Bolt, 5/16-18 X 3/4" Hex Head Black Nylon	F05006-45	1	
29	Nut, 5/16-18 Hex Black Nylon	F05010-86	1	
	Tube, 5/8" Heat Shrink	R01950-5	.10 Ft	◆
	Grommet, 5/8" Wire	P04137	1	

¹ Stainless Steel Bolt F05006-143 replaces F05006-44 to prevent corrosion (12/09).

² 015885 used to service sawmill prior to solenoid being added to fuse box (LT30HD and LT40HD Rev. G7.00). [See Section 5.10](#) for cable service assemblies for later revisions.

³ 015264 not available for service. Use kit 007717 ([See Section 10.6](#)).

⁴ Contact mount bracket and contact mounting hardware upgraded with Rev. J1.01 to improve ground contact with bottom track rail. Use kit 010104 to upgrade ground contact parts ([See Section 10.6](#)).

⁵ 024676 used to service sawmill prior to solenoid being added to fuse box (LT30HD and LT40HD Rev. G7.00). [See Section 5.10](#) for cable service assemblies for later revisions.

⁶ Quantity changed from 14 to 8 (2/97).

10 Hydraulic System

Hydraulic Log Loader

10.8 Hydraulic Log Loader

LT30HD
LT40HD

Rev. H7.00 - J7.00
Rev. H7.00 - J8.00

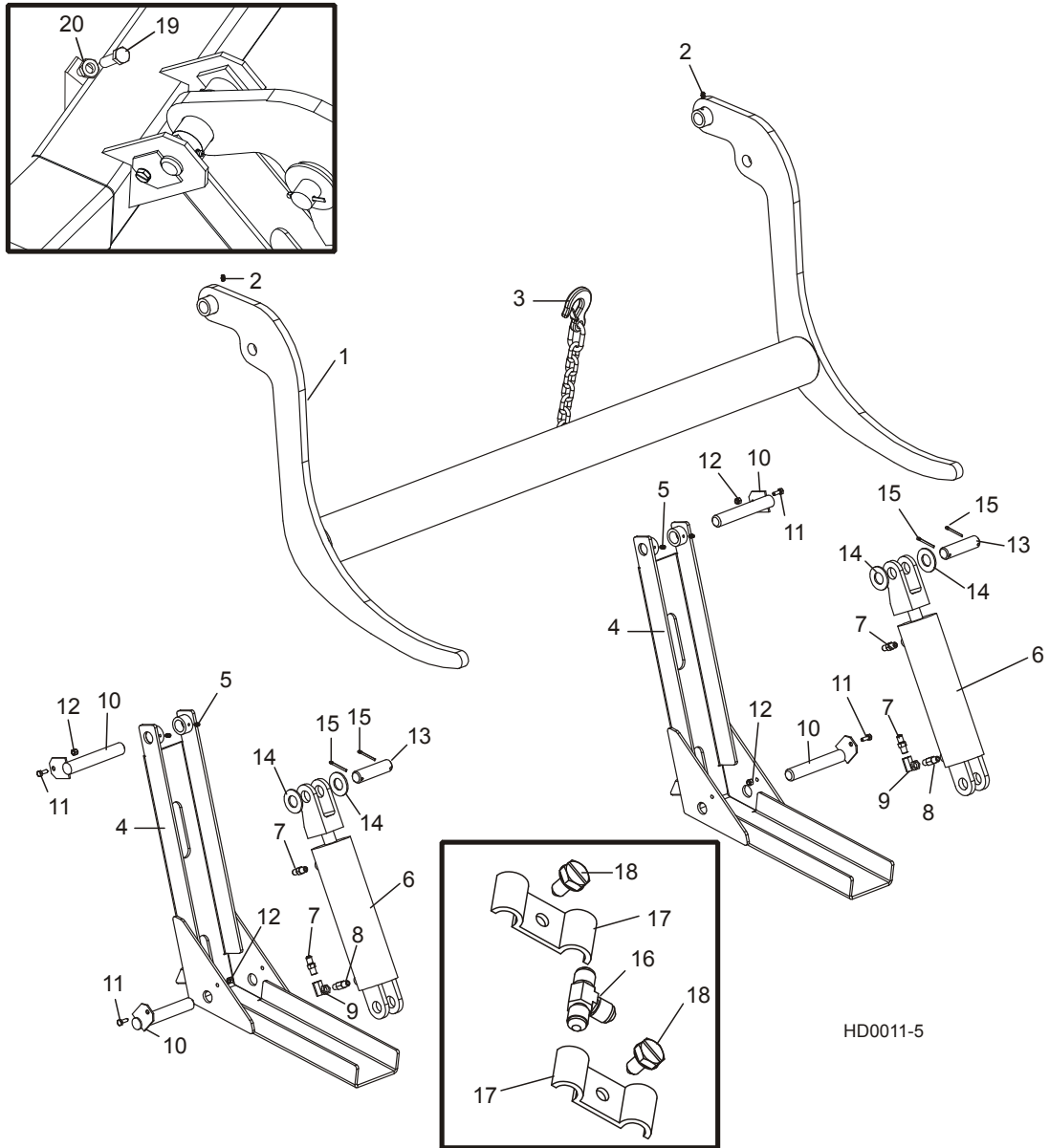

REF	DESCRIPTION (◆ Indicates Parts Available In Assemblies Only)	PART #	QTY.
	LOADER KIT, HYDRAULIC LOG (LT30HD)	LTHDLA-30H	1
	LOADER KIT, HYDRAULIC LOG (LT40HD)	LTHDLA	1
1	Arm, Hydraulic Log Loading	W11805	1
2	Fitting, 3/16" Grease	P04107	2
3	Chain, Hydraulic Log Loader Safety	A04376	1

4	Channel, Hydraulic Log Loading Foot	W09444	2	
5	Fitting, 3/16" Grease	P04107	4	
	Cylinder Assembly, Hydraulic Log Loading Arm	A09284 ¹	2	◆
6	Cylinder, 8" X 3" Hydraulic	P12847	1	
	Seal Kit, 8" x 3" Hydraulic Cylinder	P12956	1	
7	Fitting, C5205x4x4 Male Connector	P09143	2	
8	Fitting, 0455x4x4 90° Swivel Elbow	P12199	1	
	Fitting Kit, 1/4NPT 5.0GPM Velocity Fuse	015832	1	
9	Fitting, 1/4NPT 5.0GPM Velocity Fuse	015750 ²	2	◆
	Instruction Sheet, Velocity Fuse Replacement	015832-255	1	
10	Pin, Loading Arm Mount	W09446	4	
11	Bolt, 1/4-20 x 3/4" Hex Head Full Thread	F05005-1 ³	4	
12	Nut, 1/4-20 Hex Lock	F05010-69 ³	4	
13	Pin, Loading Arm Cylinder Mount	S09251	2	
14	Washer, 1" SAE Flat	F05011-28	4	
15	Pin, 3/16" X 1 1/2" Cotter	F05012-23	4	
16	Fitting, C5705x5x4 Union 'T'	P09145	2	
17	Clamp, 1/4" Hydraulic Hose	S09245	6	
18	Bolt, 5/16-18 X 3/4" Hex Head Grade 5	F05006-102 ⁴	6	
19	BOLT, 1/2-13 X 2" HEX HEAD FULL THREAD GRADE 5	F05008-116 ⁵	2	
20	NUT, 1/2-13 JAM	F05010-31	2	

¹ Cylinder assembly no longer available for service. Sell cylinder w/o fittings P12847 to insure compatibility of velocity fuses.

² 015750 velocity fuse changed from 4.0GPM to 5.0GPM 9/02.

³ Hex Head Bolt F05005-1 and Lock Nut F05010-69 replace Self-Tapping Screws F05015-30 originally used prior to Rev. H2.00. Bolt and nut easier to assemble.

⁴ Grade 5 Hex Head Bolt F05006-102 replaces self-tapping bolt F05006-30 to eliminate shearing of bolts head (4/08).

⁵ Replaces F05008-88 1/2-13 x 1 3/4" Hex Head Grade 5 Bolt supplied prior to Rev. H8.01 to provide increased adjustment.

10.9 Hydraulic Log Loader

LT30HD
LT40HD

Rev. G1.00 - H6.02
Rev. G1.00 - H6.02

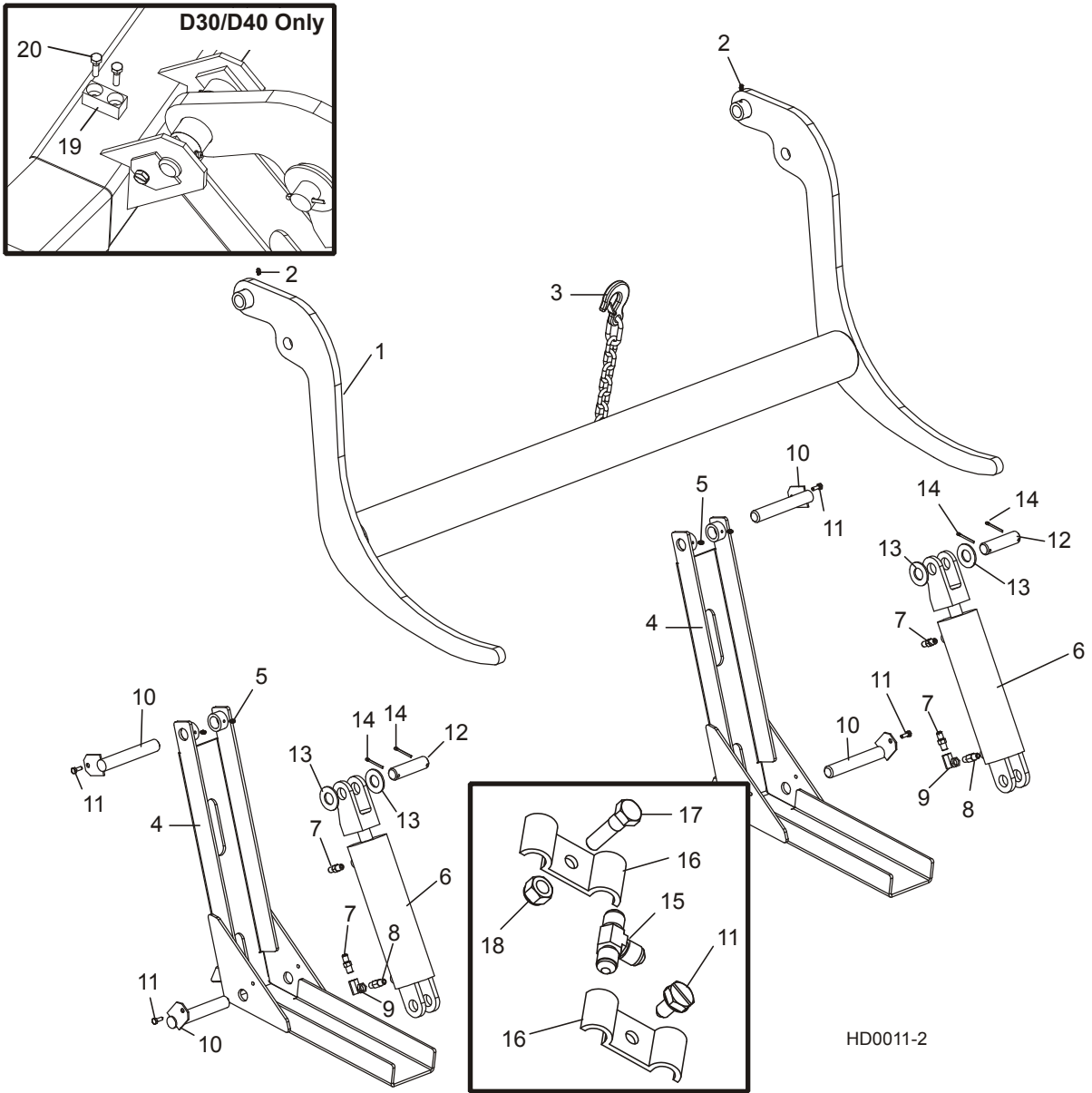

REF	DESCRIPTION (◆ Indicates Parts Available In Assemblies Only)	PART #	QTY.
	LOADER KIT, HYDRAULIC LOG (LT30HD)	LTHDLA-30H	1
	LOADER KIT, HYDRAULIC LOG (LT40HD)	LTHDLA	1
1	Arm, Hydraulic Log Loading	W11805	1
2	Fitting, 3/16" Grease	P04107	2
3	Chain, Hydraulic Log Loader Safety	A04376	1

4	Channel, Hydraulic Log Loading Foot	W09444	2	
5	Fitting, 3/16" Grease	P04107	4	
	Cylinder Assembly, Hydraulic Log Loading Arm	A09284 ¹	2	◆
6	Cylinder, 8" X 3" Hydraulic	P12847	1	
	Seal Kit, 8" x 3" Hydraulic Cylinder	P12956	1	
7	Fitting, C5205x4x4 Male Connector	P09143	2	
	Fitting Kit, 1/4NPT 5.0GPM Velocity Fuse	015832	1	
8	Fitting, 1/4NPT 5.0GPM Velocity Fuse	015750 ²	2	◆
	Instruction Sheet, Velocity Fuse Replacement	015832-255	1	
9	Fitting, 0455x4x4 90° Swivel Elbow	P12199	1	
10	Pin, Loading Arm Mount	W09446	4	
11	Bolt, 1/4-20 x 3/4" Hex Head Full Thread	F05005-1 ³	4	
12	Nut, 1/4-20 Hex Lock	F05010-69 ³	4	
13	Pin, Loading Arm Cylinder Mount	S09251	2	
14	Washer, 1" SAE Flat	F05011-28	4	
15	Pin, 3/16" X 1 1/2" Cotter	F05012-23	4	
16	Fitting, C5705x5x4 Union 'T'	P09145	2	
17	Clamp, 1/4" Hydraulic Hose	S09245	6	
18	Bolt, 5/16-18 X 3/4" Hex Head Grade 5	F05006-102 ⁴	6	
19	BLOCK, LOADING ARM STOP (DIESEL MODELS ONLY)	014169	2	
20	BOLT, 1/4-20 X 1" SELF-TAPPING HEX HEAD	F05005-87	4	

¹ Cylinder assembly no longer available for service. Sell cylinder w/o fittings P12847 to insure compatibility of velocity fuses.

² Replaces 3.0GPM velocity fuse P11566 on Rev. G3.00 and later mills. 015750 velocity fuse changed from 4.0GPM to 5.0GPM 9/02.

³ Hex Head Bolt F05005-1 and Lock Nut F05010-69 replace Self-Tapping Screws F05015-30 originally used prior to Rev. H2.00. Bolt and nut easier to assemble.

⁴ Grade 5 Hex Head Bolt F05006-102 replaces self-tapping bolt F05006-30 to eliminate shearing of bolts head (4/08).

10.10 Hydraulic Log Turner

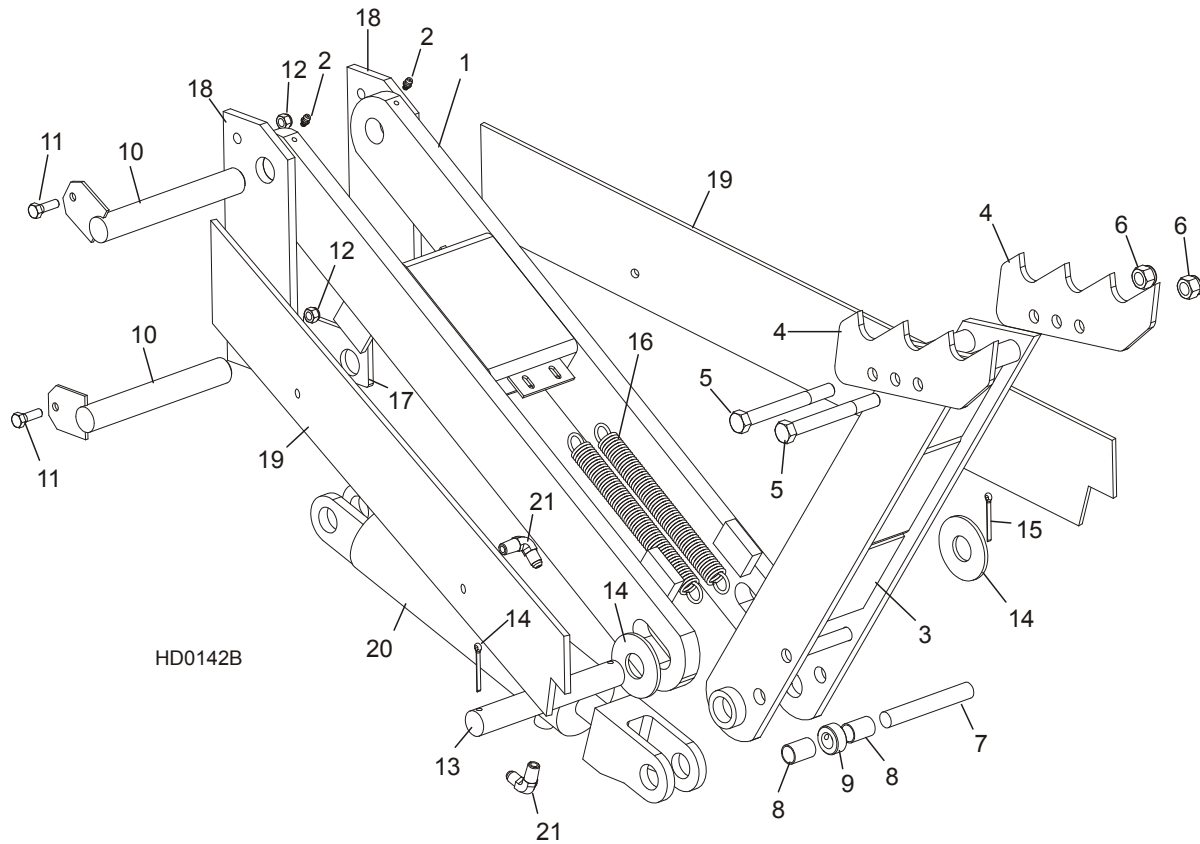

REF	DESCRIPTION (◆ Indicates Parts Available In Assemblies Only)	PART #	QTY.
1	ARM, HYDRAULIC LOG TURNER LINK	015231	1
2	Fitting, 3/16" Grease	P04107	2
3	ARM, HYDRAULIC LOG TURNER PAINTED	015233 ¹	1
4	CLAW, HYDRAULIC LOG TURNER	014675	2
5	BOLT, 1/2-13 X 5" HEX HEAD GRADE 5	F05008-66	2
6	NUT, 1/2-13 HEX LOCK	F05010-3	2
7	PIN, LOG TURNER STOP	S09211 ²	1
8	SPACER, LOG TURNER STOP PIN	S09913 ²	2
9	COLLAR, 5/8" I.D. WITH SET SCREW	P05035 ²	1
10	PIN, LOG TURNER MOUNT	015085	2
11	BOLT, 5/16-18 X 1" HEX HEAD GRADE 2	F05006-1	2
12	NUT, 5/16-18 HEX LOCK	F05010-6	2
13	PIN, LOG TURNER PIVOT	S09246	1
14	WASHER, 1" SAE FLAT	F05011-28	2
15	PIN, 3/16" X 1 1/2" COTTER	F05012-23	2

16	SPRING, HYDRAULIC LOG TURNER	015718 ³	2	
17	PLATE, LOG TURNER CYLINDER MOUNT	S09155	1	
18	PLATE, LOG TURNER MOUNT	S09109	2	
19	PLATE, LOG TURNER BRACE	S09605	2	
	CYLINDER ASSEMBLY, HYDRAULIC LOG TURNER	A09286	1	
20	Cylinder, 8" X 2 1/2" Hydraulic	P12846	1	◆
	Seal Kit, 8" x 2 1/2" Hydraulic Cylinder	P12955	1	
21	Fitting, 90° Male Elbow	P09142	2	
	WASHER, 1/2" SAE FLAT	F05011-2 ⁴	4	

¹ Arm redesigned 5/97 and 6/97. New arm features less parts and welded stop pin. This arm will service all hydraulic log turners.

² Parts not required if turner arm 015233 replaced after 5/97. New arm includes welded stop pin.

³ Replaces P09136 (LT30HD/40HD rev. G2.04).

⁴ Added LT30HD/40HD rev. G9.00+.

10.11 Hydraulic Log Side Supports

LT30HD
LT40HD

Rev. H8.00 - J7.00
Rev. H8.00 - J8.00

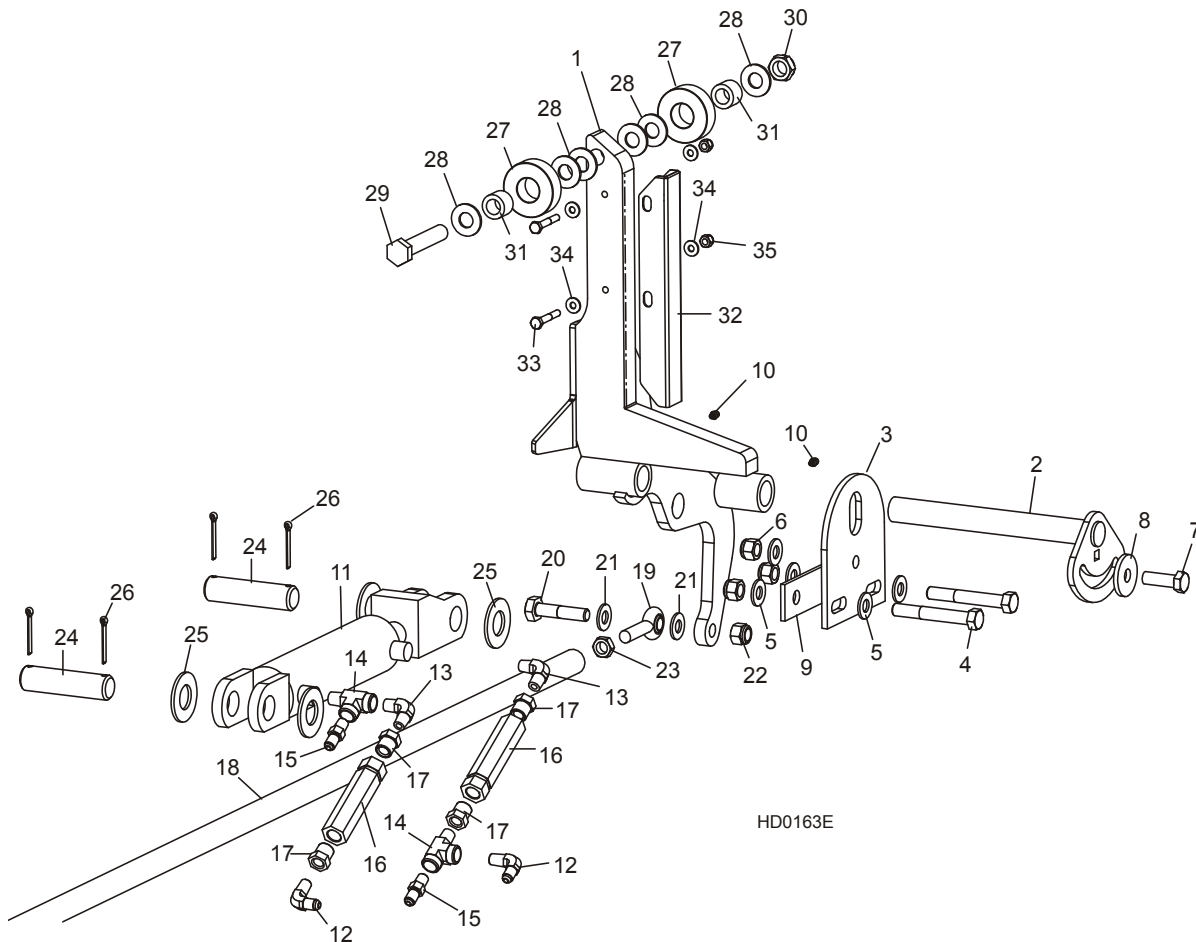

REF	DESCRIPTION (◆ Indicates Parts Available In Assemblies Only)	PART #	QTY.
1	SUPPORT, HYDRAULIC LOG SIDE	W12339	2
	MOUNTING KIT, HYDRAULIC LOG SIDE SUPPORT	016559 ¹	2
2	Pin, Log Side Support Pivot	016544	1
3	Plate, Log Side Support End	016555	1
4	Bolt, 1/2-13 X 3 1/2" Hex Head Grade 5	F05008-61	2
5	Washer, 1/2" SAE Flat	F05011-2	5
6	Nut, 1/2-13 Hex Nylon Lock	F05010-8	3
7	Bolt, 1/2-13 X 1 1/2" Hex Head Grade 5	F05008-33	1
8	Washer, .52" x 1.69"	014632 ²	1
9	Plate, Side Support Washer Clamp	016558	1
10	FITTING, 3/16" GREASE	P04107	4

CYLINDER ASSEMBLY, HYDRAULIC LOG SIDE SUPPORT		A09283	1	
11	Cylinder, 6" X 2" Hydraulic	P12845	1	
	Seal Kit, 6" x 2" Hydraulic Cylinder	P12954	1	
12	Fitting, 90° Male Elbow	P09142	2	
13	Fitting, C3529x4 90° Pipe	P09140	2	
14	Fitting, C3759x4 Male 'T'	P09141	2	
15	Fitting, C5205x4x4 Male Connector	P09143	2	
16	Valve, Hydraulic Sequence	015484 ³	2	
17	Fitting, 3/8" NPT - 1/4" NPT Reducer	015490	4	
18	ROD, HYDRAULIC SIDE SUPPORT LINK	015026	1	
19	END, 1/2" ROD	P09137	2	
20	BOLT, 1/2-13 X 2 1/4" HEX HEAD GRADE 5	F05008-10	2	
21	WASHER, 1/2" SAE FLAT	F05011-2	4	
22	NUT, 1/2-13 HEX NYLON LOCK	F05010-8	2	
23	NUT, 1/2-20 HEX JAM	F05010-16	1	
24	PIN, CYLINDER MOUNT	S09251	2	
25	WASHER, 1" SAE FLAT	F05011-28	4	
26	PIN, 3/16" X 1 1/2" COTTER	F05012-23	4	
	ROLLER KIT, SIDE SUPPORT	016562 ⁴	2	
27	Roller, Side Support	016561	2	
28	Washer, 5/8" SAE Flat	F05011-5 ⁵	6	
29	Bolt, 5/8-11 x 3 3/4" Hex Head Grade 5	F05009-118 ⁶	1	
30	Nut, 5/8-11 Hex Nylon Lock Jam	F05010-96 ⁷	1	
31	Bushing, Bronze 5/8" x 1" x 3/4"	016560	2	
	Bolt, 1/2-13 x 3 1/2" Carriage Head	F05008-94	1	
	Instruction Sheet, Side Support Roller	016562-526	1	
	GUARD KIT, STAINLESS STEEL SIDE SUPPORT (OPTIONAL)	016798 ⁸	1	
32	Guard, Stainless Steel Side Support	016722	4	
33	Bolt, 1/4-20 x 1 3/4" Hex Head	F05005-4	8	
34	Washer, 1/4" SAE Flat	F05011-11	16	
	Washer, 5/8" SAE Flat	F05011-5 ⁵	4	
35	Nut, 1/4-20 Hex Nylon Lock	F05010-69	8	
	Instruction Sheet, Stainless Steel Side Support Guard Retro	016798-1005	1	

¹ Mounting Kit 016559 replaces kit K09344 supplied prior to Rev. H8.00. New mounting pin, plate and clamp plate improve stability of side support adjustment.

² Oversized Washer 014632 replaces 1/2" SAE Flat Washer F05011-2 to provide larger clamping area during adjustment (12/09). Flat Washer F05011-2 replaced F05011-90 .5" x 1.63" Serrated Washer supplied prior to Rev. H8.01. Serrated Washer no longer required with current side support mount arrangement.

³ Grooves added to one end of valve to assist in proper orientation during assembly/replacement (3/01).

⁴ Roller Kit 016562 replaces kit 015109 supplied prior to Rev. H8.00. Carriage bolt supplied to replace bed rail mounting bolt to allow clearance for side support roller hardware when side support is adjusted down.

⁵ Additional 5/8" SAE Flat Washer F05011-5 may be required on each side of side support to provide clearance for optional stainless steel side support guards. Extra washers are included in the stainless steel guard retrofit kit (016798).

⁶ Longer bolt replaces 3 1/2" F05009-93 used before 3/07.

⁷ Replaces F05010-4 Hex Lock Nut used prior to 9/06 for ease of assembly.

10 Hydraulic System

Hydraulic Log Side Supports

⁸ Stainless Steel Guards added Rev. J2.00. Guards prevent staining of lumber and reduce wear to side support. Guard revised with thicker steel and second mounting hole (LT30HD Rev. J5.00 & LT40HD Rev. J6.00).

10.12 Hydraulic Log Side Supports

LT30HD
LT40HD

Rev. H5.00 - H7.00
Rev. H5.00 - H7.00

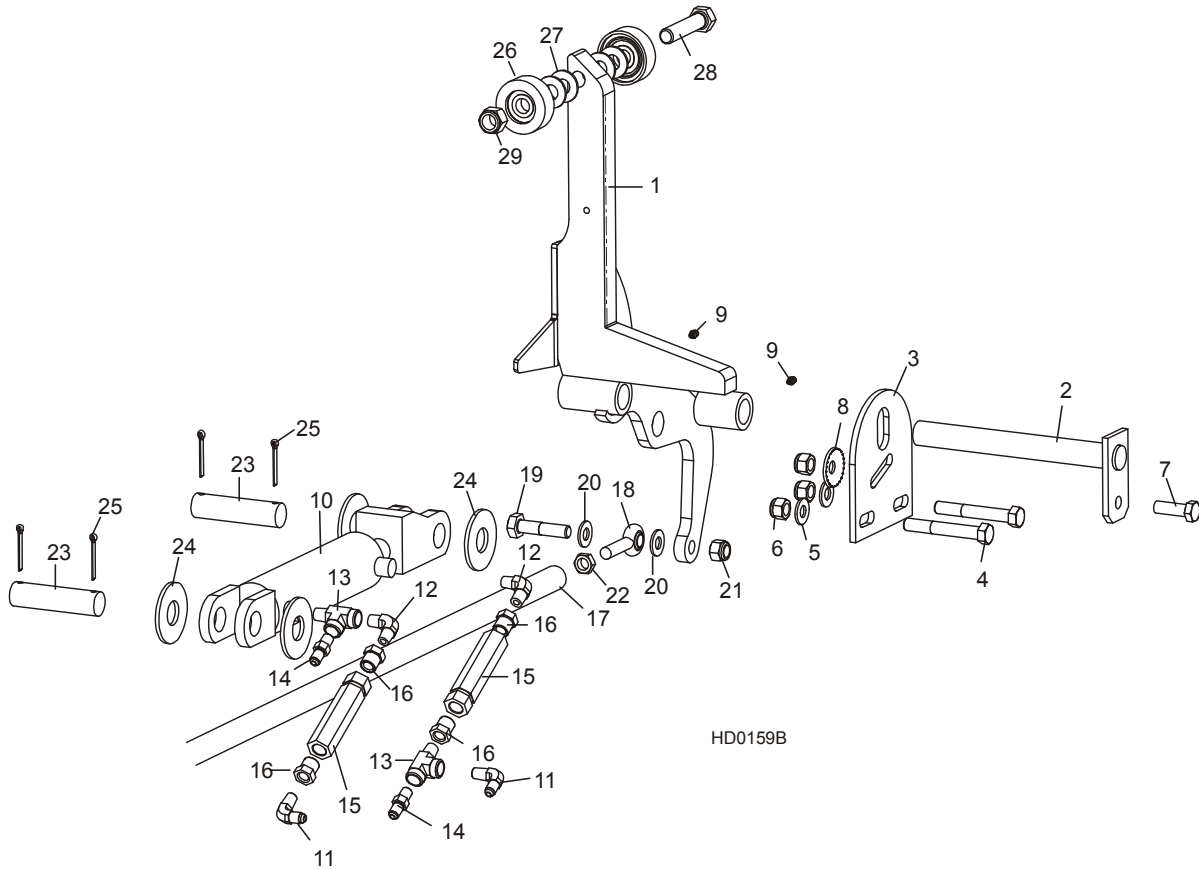

REF	DESCRIPTION (◆ Indicates Parts Available In Assemblies Only)	PART #	QTY.
1	SUPPORT, HYDRAULIC LOG SIDE	W12339	2
	MOUNTING KIT, HYDRAULIC LOG SIDE SUPPORT	K09344 ¹	2
2	Pin, Log Side Support Pivot	W09238	1
3	Plate, Log Side Support End	S09148	1
4	Bolt, 1/2-13 X 3 1/2" Hex Head	F05008-15	2
5	Washer, 1/2" SAE Flat	F05011-2	2
6	Nut, 1/2-13 Hex Nylon Lock	F05010-8	3
7	Bolt, 1/2-13 X 1 1/2" Hex Head Grade 5	F05008-33	1
8	Washer, .5" x 1.63" Serrated	F05011-90	1
9	FITTING, 3/16" GREASE	P04107	4
	CYLINDER ASSEMBLY, HYDRAULIC LOG SIDE SUPPORT	A09283	1
10	Cylinder, 6" X 2" Hydraulic	P12845	1
	Seal Kit, 6" x 2" Hydraulic Cylinder	P12954	1
11	Fitting, 90° Male Elbow	P09142	2

10

Hydraulic System

Hydraulic Log Side Supports

12	Fitting, C3529x4 90° Pipe	P09140	2	
13	Fitting, C3759x4 Male 'T'	P09141	2	
14	Fitting, C5205x4x4 Male Connector	P09143	2	
15	Valve, Hydraulic Sequence	015484 ²	2	
16	Fitting, 3/8" NPT - 1/4" NPT Reducer	015490	4	
17	ROD, HYDRAULIC SIDE SUPPORT LINK	015026	1	
18	END, 1/2" ROD	P09137	2	
19	BOLT, 1/2-13 X 2 1/4" HEX HEAD GRADE 5	F05008-10	2	
20	WASHER, 1/2" SAE FLAT	F05011-2	4	
21	NUT, 1/2-13 HEX NYLON LOCK	F05010-8	2	
22	NUT, 1/2-20 HEX JAM	F05010-16	1	
23	PIN, CYLINDER MOUNT	S09251	2	
24	WASHER, 1" SAE FLAT	F05011-28	4	
25	PIN, 3/16" X 1 1/2" COTTER	F05012-23	4	
	ROLLER KIT, SIDE SUPPORT	015109 ³	2	◆
26	Roller Assembly, Side Support	015014	2	◆
27	Washer, 5/8" SAE Flat	F05011-5	4	
28	Bolt, 5/8-11 x 3" Hex Head Grade 5	F05009-37	1	
29	Nut, 5/8-11 Nylon Lock	F05010-34	1	
	Instruction Sheet, Side Support Roller	015109-526	1	◆

¹ Upgrade mounting kit 016559 also available. Replaces Pin Weldment and Mounting Plate to new design to improve stability of side support adjustment ([See Section 10.11](#)).

² Grooves added to one end of valve to assist in proper orientation during assembly/replacement (3/01).

³ Roller kit replaced by new kit 016562 ([See Section 10.11](#)).

10.13 Hydraulic Log Side Supports

LT30HD
LT40HD

Rev. G1.00 - H4.00
Rev. G1.00 - H4.00

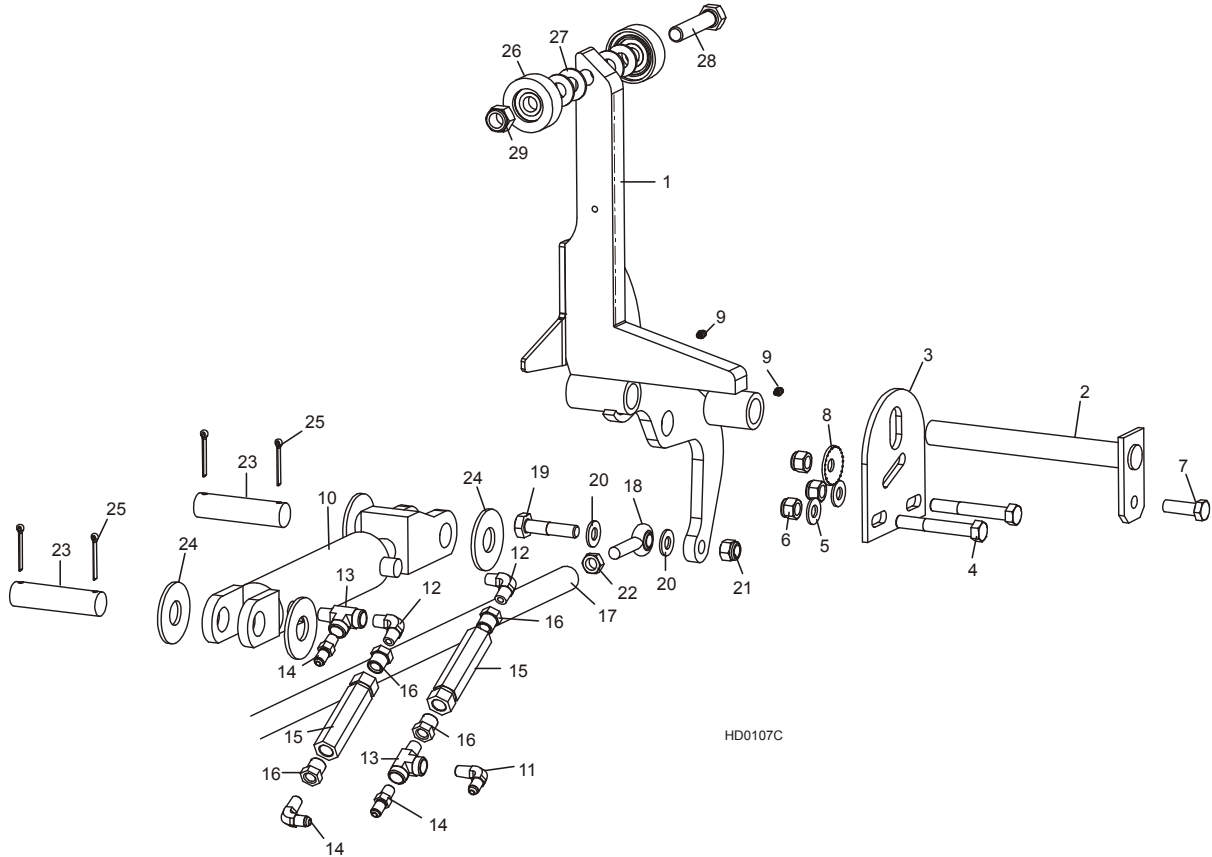

HD0107C

REF	DESCRIPTION (◆ Indicates Parts Available In Assemblies Only)	PART #	QTY.
1	SUPPORT, HYDRAULIC LOG SIDE	W12339 ¹	2
	MOUNTING KIT, HYDRAULIC LOG SIDE SUPPORT	K09344 ²	2
2	Pin, Log Side Support Pivot	W09238	1
3	Plate, Log Side Support End	S09148	1
4	Bolt, 1/2-13 X 3 1/2" Hex Head	F05008-15	2
5	Washer, 1/2" SAE Flat	F05011-2	2
6	Nut, 1/2-13 Hex Nylon Lock	F05010-8	3
7	Bolt, 1/2-13 X 1 1/2" Hex Head Grade 5	F05008-33	1
8	Washer, .5" x 1.63" Serrated	F05011-90 ³	1
9	FITTING, 3/16" GREASE	P04107	4
	CYLINDER ASSEMBLY, HYDRAULIC LOG SIDE SUPPORT	A09283 ⁴	1
10	Cylinder, 6" X 2" Hydraulic	P12845	1
	Seal Kit, 6" x 2" Hydraulic Cylinder	P12954	1
11	Fitting, 90° Male Elbow	P09142	1

10

Hydraulic System

Hydraulic Log Side Supports

12	Fitting, C3529x4 90° Pipe	P09140	2	
13	Fitting, C3759x4 Male 'T'	P09141	2	
14	Fitting, C5205x4x4 Male Connector	P09143 ⁴	3	
15	Valve, Hydraulic Sequence	015484 ⁴	2	
16	Fitting, 3/8" NPT - 1/4" NPT Reducer	015490	4	
17	ROD, HYDRAULIC SIDE SUPPORT LINK	015026	1	
18	END, 1/2" ROD	P09137	2	
19	BOLT, 1/2-13 X 2 1/4" HEX HEAD GRADE 5	F05008-10	2	
20	WASHER, 1/2" SAE FLAT	F05011-2	4	
21	NUT, 1/2-13 HEX NYLON LOCK	F05010-8	2	
22	NUT, 1/2-20 HEX JAM	F05010-16	1	
23	PIN, CYLINDER MOUNT	S09251	2	
24	WASHER, 1" SAE FLAT	F05011-28	4	
25	PIN, 3/16" X 1 1/2" COTTER	F05012-23	4	
	ROLLER KIT, SIDE SUPPORT	015109 ⁵	2	◆
26	Roller Assembly, Side Support	015014	2	◆
27	Washer, 5/8" SAE Flat	F05011-5	4	
28	Bolt, 5/8-11 x 3" Hex Head Grade 5	F05009-37	1	
29	Nut, 5/8-11 Nylon Lock	F05010-34	1	
	Instruction Sheet, Side Support Roller	015109-526	1	◆

¹ Revised to include 015977 side support stop for added strength LT30HD/40HD Rev. G6.00. Use painted W12339 side support to replace unpainted 015010.

² Upgrade mounting kit 016559 also available. Replaces Pin Weldment and Mounting Plate to new design to improve stability of side support adjustment ([See Section 10.11](#)).

³ Replaces 014632 and S09225 originally supplied. Serrated washer helps maintain side support adjustment.

⁴ Cylinder assembly includes two 015484 sequence valves. 015484 replaces A09207 valves originally supplied on standard HD until 4/97. Cylinder assembly includes elbow fitting for hose connected to base end of log turner cylinder. Replacement of cylinder assembly on LT30HD/40HD prior to Rev. H5.00 requires longer hose P12535. Grooves added to one end of valve to assist in proper orientation during assembly/replacement (3/01).

⁵ Roller kit replaced by new kit 016562 ([See Section 10.11](#)).

10.14 Hydraulic Log Side Supports (Middle - Optional)

LT30HD
LT40HD

Rev. G6.00+
Rev. G6.00+

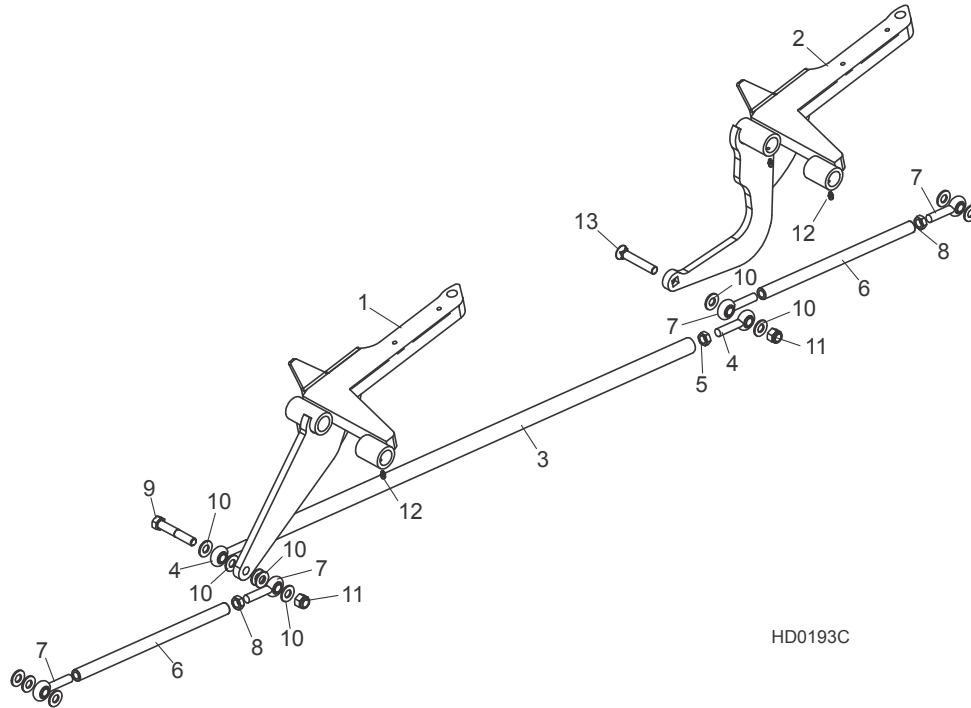

REF	DESCRIPTION (◆ Indicates Parts Available In Assemblies Only)	PART #	QTY.
	SUPPORT ASSEMBLY, HYDRAULIC 4-LINK SIDE	HSS-A ¹	1
1	Support Weldment, Front Log Side	048436	1
2	Support Weldment, Rear Log Side	048438 ²	1
3	Rod, 4-Link Side Support	048537	1
4	Rod End, 1/2 Male	P09137	2
5	Nut, 1/2-20 Hex Jam	F05010-16	1
	Rod Assembly, 4-Link Side Support Short	048247	2
6	Rod, 4-Link Connecting	048246	1
7	Rod End, 1/2 Male	P09137	2
8	Nut, 1/2-20 Hex Jam	F05010-16	1
9	Bolt, 1/2-13 x 3" Hex Head Grade 5	F05008-23	1
10	Washer, 1/2" SAE Flat	F05011-2	6
11	Nut, 1/2-13 Nylon Hex Lock	F05010-8	2
12	Fitting, 3/16 x 3/16 Straight Grease	P04107	4
13	Bolt, 1/2-13 x 3" Flat Head Plow Grade 5	F05008-158 ²	1

¹ HSS 4-Link Side Supports available 2/05. HSS-A may be used to retrofit sawmills after Rev. G6.00 to make all four sides supports hydraulically operated.

² Flat Head Bolt F05008-158 replaces welded stud on Rear Side Support 048438 to improve durability (9/05).

10.15 Hydraulic Log Clamp

LT30HD
LT40HD

Rev. H3.00 - J7.00
Rev. H3.00 - J8.00

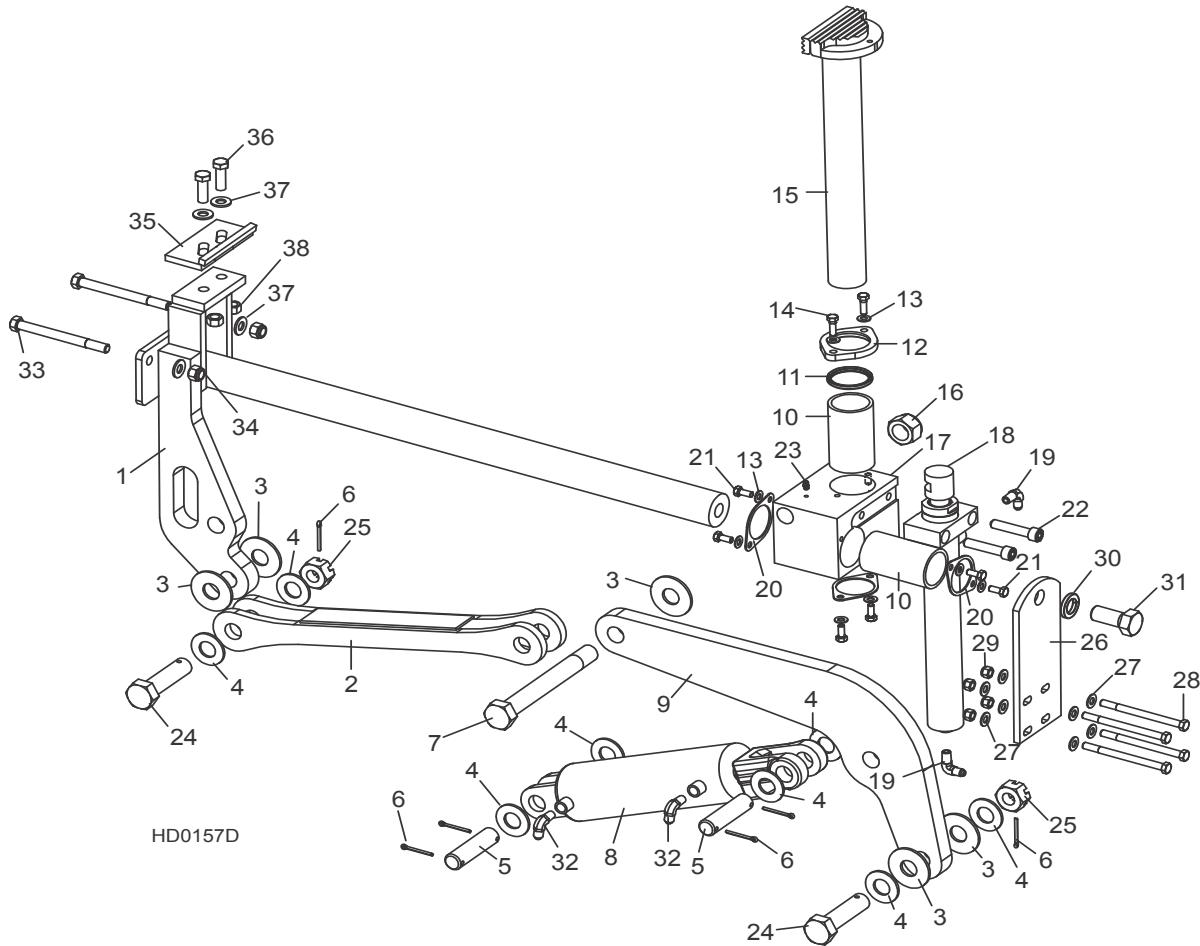

REF	DESCRIPTION (◆ Indicates Parts Available In Assemblies Only)	PART #	QTY.
	CLAMP ASSEMBLY, HYDRAULIC 2-PLANE	017264	1
1	Mount Weldment, Hydraulic Clamp Slide	017265	1
2	Link Weldment, Hydraulic Clamp	017267	1
3	Washer, 1/8" x 2 1/2" Hardened	015057	5
4	Washer, 1" SAE Flat	F05011-28	8
5	Pin, 1" x 3.88"	S09251	2
6	Pin, 3/16" x 1 1/2" Cotter	F05012-23	6
7	Bolt, 1-14 x 8 1/2" Hex Head Grade 8	015049	1
8	Cylinder, 3" x 7" Hydraulic	017275	1
	Seal Kit, Hydraulic Cylinder	P12956	1
9	Arm, Clamp Pivot	017274	1
10	Bushing, Clamp Slide	015088	2

	Wiper Assembly, Vertical Clamp Rod	017271	1	
11	Wiper, Vertical Clamp Rod	017273	1	
12	Flange, Vertical Clamp Rod Wiper	017272	1	
13	Washer, 5/16" SAE Flat	F05011-17	8	
14	Bolt, 5/16-18 x 1" Hex Head	F05006-1	2	
15	Clamp Weldment, Vertical	015043	1	
16	Nut, 1-14 Hex Jam	F05010-118	2	
17	Block, Hydraulic Clamp Slide	017270	1	
18	Cylinder Weldment, Vertical Clamp Hydraulic	015050	1	
	Seal Kit, Hydraulic Cylinder	016204	1	
	Instruction Sheet, Vertical Clamp Seal Replacement	016204-1009	1	
19	Fitting, 1/4" NPT x 1/4" JIC Elbow	P09142	2	
20	Retainer, Clamp Bushing	017242	3	
21	Bolt, 5/16-18 x 3/4" Hex Head	F05006-5	6	
22	Bolt, 1/2-13 x 2 1/2" Socket Head	F05008-39	2	
23	Fitting, 3/16" Straight Grease	P04107	1	
24	Bolt, 1-14 x 3 3/4" Hex Head Grade 8 w/Hole	015072 ¹	2	
25	Nut, 1-14 Slotted Hex	F05010-163	2	
26	Plate, Log Clamp Mount	015068	1	
27	Washer, 3/8" SAE Flat	F05011-3	8	
28	Bolt, 3/8-16 x 5" Hex Head	F05007-5	4	
29	Nut, 3/8-16 Hex Nylon Lock	F05010-10	4	
30	Washer, 7/8" Split Lock	F05011-46	1	
31	Bolt, 7/8-14 x 2" Hex Head Grade 5	F05014-2	1	
32	Fitting, 1/4" NPT - 3/8" JIC Elbow	015491	2	
33	Bolt, 1/2-13 x 5 1/2" Hex Head Grade 5	F05008-28	2	
34	Nut, 1/2-13 Hex Nylon Lock	F05010-8	2	
	Clamp Stop Kit, Hydraulic Log	K09485	1	
35	Plate, Clamp Stop	W09404	1	
36	Bolt, 1/2-13 X 1 1/2" Hex Head Grade 5	F05008-33	2	
37	Washer, 1/2" SAE Flat	F05011-2	2	
38	Nut, 1/2-13 Hex Lock	F05010-3	2	

¹ Bolt shortened from 4" to 3 3/4" to reduce interference on LT60HD/60HD models. 4" bolts can be used on other models (1/04).

10.16 Hydraulic Log Clamp

LT30HD
LT40HD

Rev. G6.00 - H2.00
Rev. G6.00 - H2.00

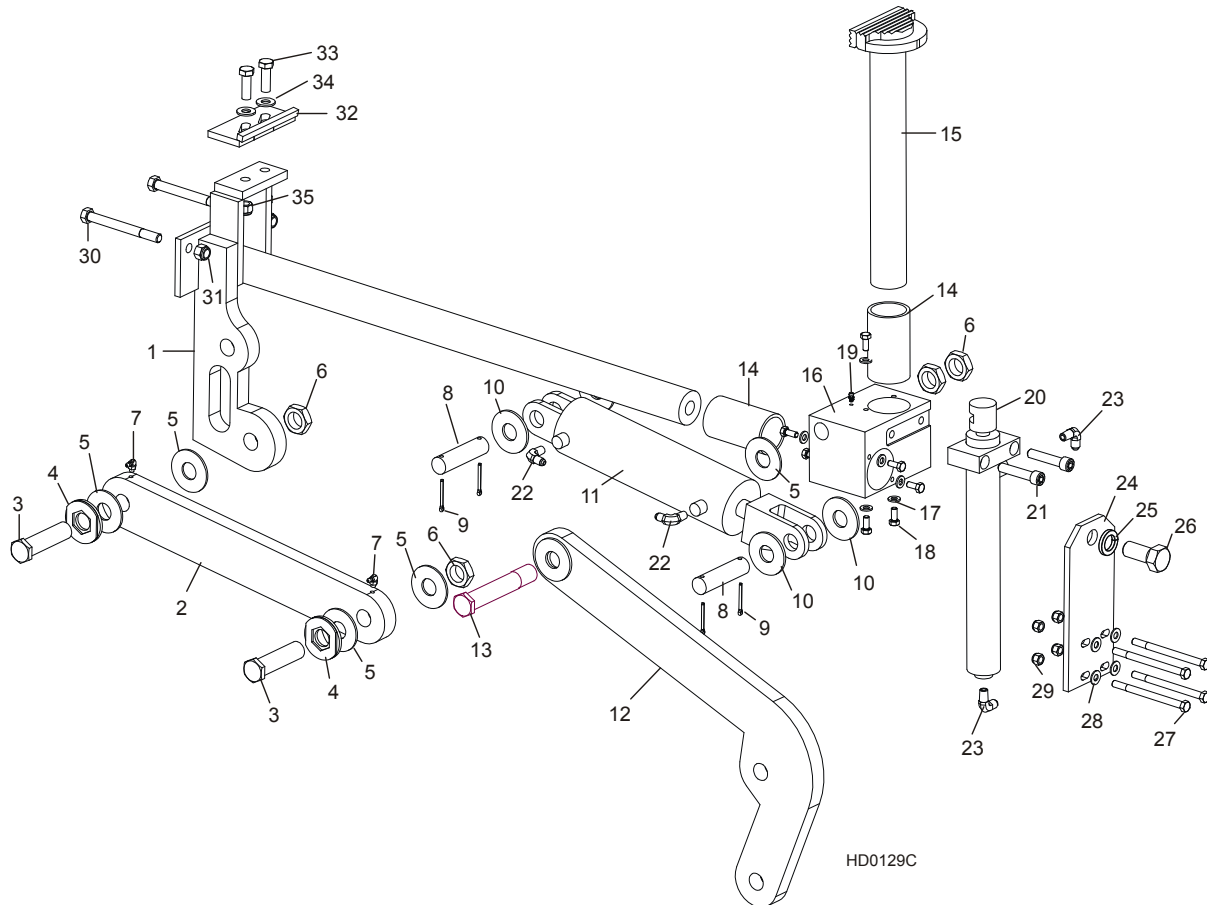

HD0129C

REF	DESCRIPTION (◆ Indicates Parts Available In Assemblies Only)	PART #	QTY.	
	CLAMP ASSEMBLY, SUPER HYDRAULIC	015036 ¹	1	◆
1	Mount Weldment, Super Clamp Tube	015037	1	
2	Arm, Clamp Link	015089	1	
3	Bolt, 1-14 x 3 3/4" Hex Head Grade 8	015072 ²	1	
4	Washer Weldment, Hex	015054	2	
5	Washer, 1/8" x 2 1/2" Hardened	015057	5	
6	Nut, 1-14 Hex Jam	F05010-118	4	
7	Fitting, 1/4-28 x 90° Grease	P04108	2	
8	Pin, 1" x 3.88" Cylinder Mount	S09251	1	
9	Pin, 3/16" x 1 1/2" Cotter	F05012-23	4	
10	Washer, 1" SAE Flat	F05011-28	4	
11	Cylinder, 3 x 7 7/8" Log Clamp In/Out	015090	1	

	Seal Kit, Hydraulic Cylinder	P12956	1	
12	Link Weldment, Super Clamp	015047	1	
13	Bolt, 1-14 x 8 1/2" Hex Head Grade 8	015049	1	
14	Bushing, Clamp Slide	015088	2	
15	Clamp Weldment, Vertical Super	015043 ³	1	
16	Block, Vertical Clamp Mount	017270 ³	1	
17	Washer, 5/16" SAE Flat	F05011-17	8	
18	Bolt, 5/16-18 x 3/4" Hex Head	F05006-5	8	
19	Fitting, 3/16" Grease	P04107	1	
20	Cylinder, Log Clamp Up/Down	015050	1	
	Seal Kit, Hydraulic Cylinder	016204	1	
	Instruction Sheet, Vertical Clamp Seal Replacement	016204-1009	1	
21	Screw, 1/2-13 x 2 1/2" Socket Head	F05008-39	2	
22	FITTING, 1/4" NPT - 1/4" JIC ELBOW	P09142	2	
23	FITTING, 1/4" NPT - 1/4" JIC ELBOW	P09142	2	
24	PLATE, SUPER LOG CLAMP MOUNT	015068	1	
25	WASHER, 7/8" SPLIT LOCK	F05011-46	1	
26	BOLT, 7/8-14 X 2" HEX HEAD GRADE 5	F05014-2	1	
27	BOLT, 3/8-16 X 5" HEX HEAD	F05007-5	4	
28	WASHER, 3/8" SAE FLAT	F05011-3	4	
29	NUT, 3/8-16 HEX NYLON LOCK	F05010-10	4	
30	BOLT, 1/2-13 X 5 1/2" HEX HEAD GRADE 5	F05008-28	2	
31	NUT, 1/2-13 HEX NYLON LOCK	F05010-8	2	
	CLAMP STOP KIT, HYDRAULIC LOG	K09485	1	
32	Plate, Clamp Stop	W09404	1	
33	Bolt, 1/2-13 X 1 1/2" Hex Head Grade 5	F05008-33	2	
34	Washer, 1/2" SAE Flat	F05011-2	2	
35	Nut, 1/2-13 Hex Nylon Lock	F05010-8	2	

¹ Clamp assembly not available. Upgrade to new clamp assembly 017264 ([See Section 10.15](#)).

² Bolt shortened from 4" to 3 3/4" to reduce interference on LT60HD/60HD models. 4" bolts can be used on other models (1/04).

³ Clamp Mount Block 015065, Vertical Clamp Weldment 015043, and Link Weldment 015047 revised on Rev. G7.00 to lower the clamp in relation to the bed frame. Replacement requires adjustment in alignment procedures for bed rails. Raise the blade to 15 5/16" (385 mm) above the clamp and then adjust bed rails 15" (375 mm) from blade. Clamp block 017270 replaces 015065 originally supplied.

10.17 Hydraulic Log Clamp

LT30HD
LT40HD

Rev. G1.00 - G5.02
Rev. G1.00 - G5.02

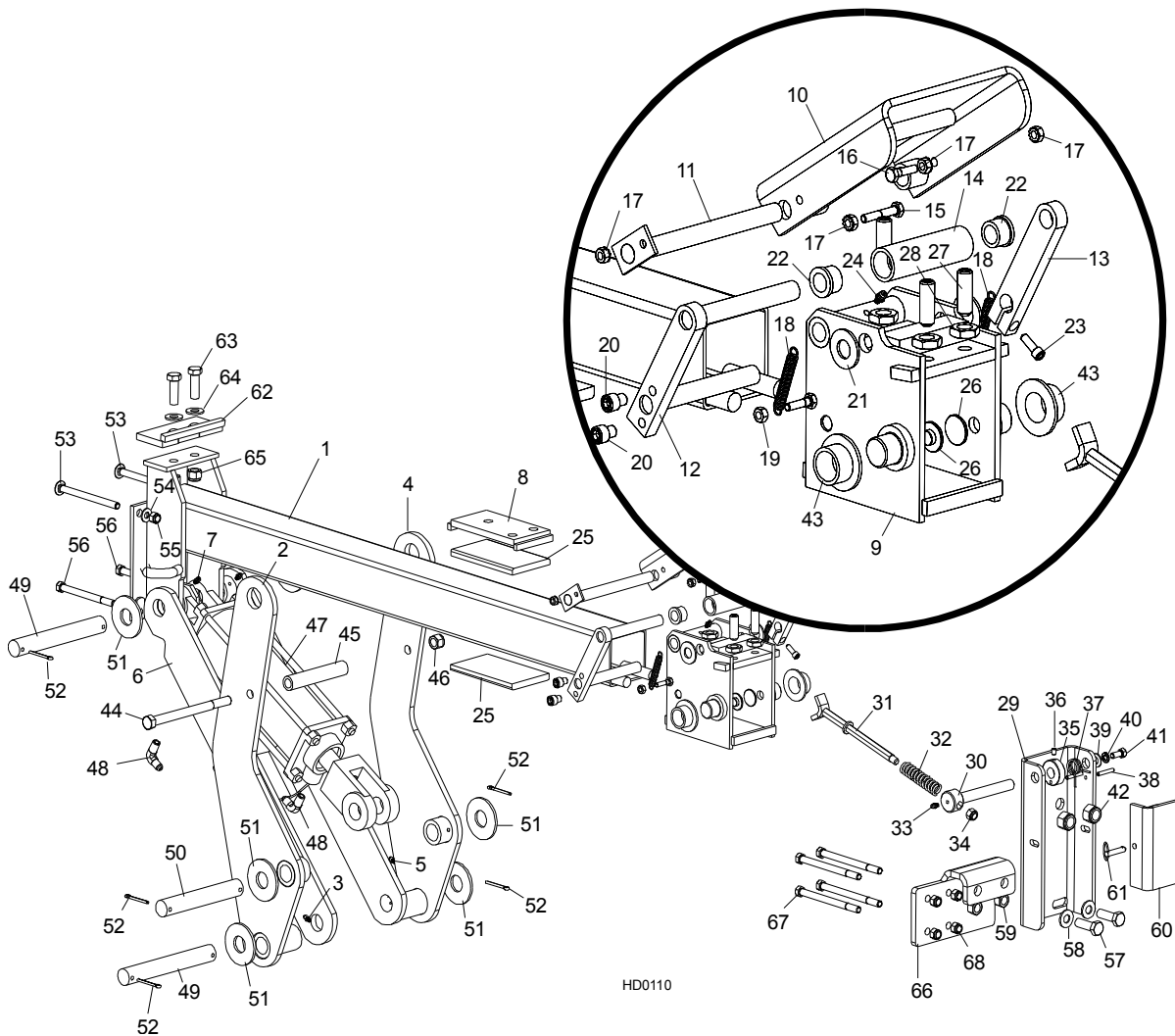

HD0110

REF	DESCRIPTION (◆ Indicates Parts Available In Assemblies Only)	PART #	QTY.	
	CLAMP KIT, 30" HYDRAULIC LOG	K09465	1	
	Clamp Assembly, 30" Hydraulic Log	A11792	1	◆
1	Tube, 30" Hydraulic Log Clamp	W11802	1	
2	Arm, 30" Hydraulic Log Clamp (Front)	W11793	1	
3	Fitting, 3/16" Straight Grease	P04107	1	
4	Arm, 30" Hydraulic Log Clamp (Rear)	W11795	1	
5	Fitting, 3/16" Straight Grease	P04107	1	
6	Arm, 30" Hydraulic Log Clamp Link	W11799	1	
7	Fitting, 3/16" Straight Grease	P04107	2	

8	Plate, Clamp Slide Pad Mount	W09422	1	
	Box/Plate Assembly, Hydraulic Clamp	A09635	1	
9	Box Weldment, Hydraulic Clamp	W12069	1	
10	Plate Weldment, Hydraulic Clamp	W12752 ¹	1	
11	Pin Weldment, Hydraulic Clamp Plate Pivot	W09639	1	
12	Arm, Clamp Prop	W09638	1	
13	Plate, Clamp Prop Arm End	S09649	1	
14	Spacer, Clamp Prop Arm	S09657	1	
15	Bolt, 1/4-20 X 1 1/2" Hex Head Grade 2	F05005-5	1	
16	Bolt, 1/4-20 X 1" Hex Head Grade 2	F05005-38	1	
17	Nut, 1/4-20 Hex Self-Locking	F05010-9	4	
18	Spring, .36 O.D. X 2.5" Extension	P11817	2	
19	Nut, 1/4-20 Hex Lock	F05010-21	2	
20	Screw, 3/8-16 X 1/2" Socket Head	F05007-50	2	
21	Washer, 5/8" SAE Flat	F05011-5	2	
22	Bushing, 5/8" I.D. Bronze	P05135	2	
23	Screw, 1/4-20 X 3/4" Socket Head	F05005-26	1	
24	Fitting, 3/16" Straight Grease	P04107	1	
25	Pad, Clamp Box Plastic Slide	S09219	2	
26	Button, Bronze	S09167	4	
27	Screw, 1/2-13 X 1 1/2" Flat Point Set	F05008-31	3	
28	Nut, 1/2-13 Hex Jam	F05010-31	3	
	Plate Assembly, Hydraulic Clamp End	014614	1	
29	Plate, Hydraulic Clamp End	S09660	1	
30	Arm Pivot, Clamp Activator	014615	1	
31	Arm, Clamp Activator	014613	1	
32	Spring, Clamp Activator Compression	014617	1	
33	Fitting, 3/16" Grease	P04107	1	
34	Nut, 3/8-16 Hex Nylon Lock	F05010-10	1	
35	Collar, Clamp Activator Arm	014616	1	
36	Screw, 1/4-20 x 3/8" Socket Head Cup Point Set	F05005-47	1	
37	Spring, Clamp Activator Torsion	014618	1	
38	Pin, 3/16" x 1 1/4" Roll	F05012-16	2	
39	Washer, 3/8" SAE Flat	F05011-3	1	
40	Washer, 5/16" Split Lock	F05011-13	1	
41	Bolt, 5/16-18 x 3/4" Hex Head	F05006-5	1	
42	Nut, 5/8-11 Hex Nylon Lock	F05010-34	2	
43	Bearing, Hydraulic Clamp Bronze	P09464	2	
44	Bolt, 1/2-13 X 6 1/2" Hex Head	F05008-6	1	
45	Spacer, Clamp	S09493	1	
46	Nut, 1/2-13 Hex Nylon Lock	F05010-8	1	
	Cylinder Assembly, Hydraulic Log Clamp	A09285	1	
47	Cylinder, 8" X 3" Hydraulic	P12847	1	◆

10

Hydraulic System

Hydraulic Log Clamp

	Seal Kit, 8" x 3" Hydraulic Cylinder	P12956	1	
48	Fitting, 90° Male Elbow	P09142	2	
49	Pin, Clamp Cylinder Mount	S09246	2	
50	Pin, Clamp Pivot	S09247	1	
51	Washer, 1" SAE Flat	F05011-28	6	
52	Pin, 3/16" X 1 1/2" Cotter	F05012-23	6	
53	Bolt, 3/8-16 X 5" Carriage Head	F05007-113	2	
54	Washer, 3/8" SAE Flat	F05011-3	2	
55	Nut, 3/8-16 Hex Nylon Lock	F05010-10	2	
56	Bolt, 3/8-16 X 4 1/2" Hex Head Grade 2	F05007-35	2	
57	Bolt, 1/2-13 X 1 1/2" Hex Head Grade 5	F05008-33	2	
58	Washer, 1/2" SAE Flat	F05011-2	2	
59	Nut, 1/2-13 Hex Lock	F05010-3	2	
	Clamp Extension Assembly	A12208	1	
60	Clamp Extension, 3" Hydraulic	W09922	1	◆
61	Pin, 5/16" X 1" Retaining	F05012-45	1	
	CLAMP STOP KIT, HYDRAULIC LOG	K09485	1	
62	Plate, Clamp Stop	W09404	1	
63	Bolt, 1/2-13 X 1 1/2" Hex Head Grade 5	F05008-33	2	
64	Washer, 1/2" SAE Flat	F05011-2	2	
65	Nut, 1/2-13 Hex Nylon Lock	F05010-8	2	
66	BRACKET, LOG CLAMP MOUNT	015252	1	
67	BOLT, 3/8-16 X 5" HEX HEAD	F05007-5	4	
68	NUT, 3/8-16 HEX NYLON LOCK	F05010-10	4	

¹ Use W12752 painted clamp plate to replace W12068 unpainted clamp plate.

10.18 Hydraulic Toe Board

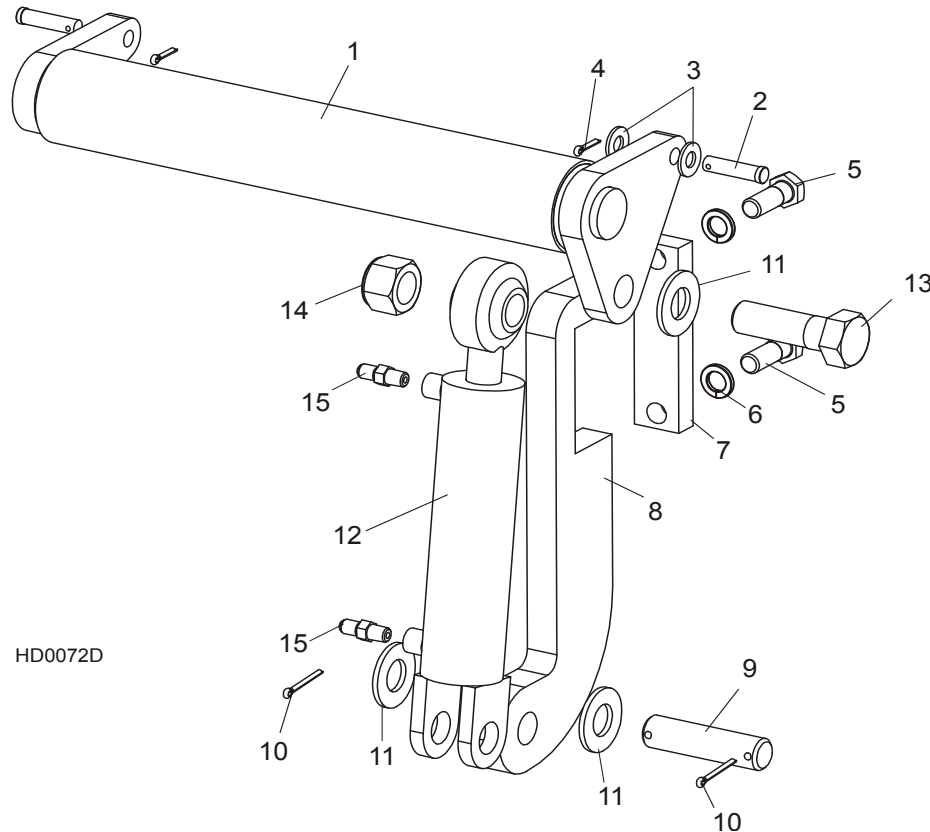

REF	DESCRIPTION (◆ Indicates Parts Available In Assemblies Only)	PART #	QTY.
1	TOE BOARD WELDMENT, HYDRAULIC	W13025	2
2	PIN, 1/2-1 3/4 CLEVIS	F05012-82	4
3	WASHER, 1/2" SAE FLAT	F05011-2 ¹	4
4	PIN, 1/8 X 3/4" COTTER	F05012-3	4
5	BOLT, 5/8-11 X 1 3/4" HEX HEAD	F05009-33	4
6	WASHER, 5/8" SPLIT LOCK	F05011-27	4
7	PLATE, HYDRAULIC TOEBOARD MOUNT	S13023	2
8	BRACKET, HYDRAULIC TOEBOARD MOUNT	S13022	2
9	PIN, CYLINDER MOUNT	S09251	2
10	PIN, 3/16" X 1 1/2" COTTER	F05012-23	4
11	WASHER, 1" SAE FLAT	F05011-28	6
12	CYLINDER, 1 1/2" X 6" HYDRAULIC TOE BOARD	014482	2
	Seal Kit, 1 1/2" x 6" Hydraulic Cylinder	014547	1
13	BOLT, 1-8 X 3 1/4" HEX HEAD GRADE 5	F05009-51	2
14	NUT, 1-8 HEX NYLON LOCK	F05010-109	2
15	FITTING, 1/4" NPT X 1/4" JIC MALE	P09143	4

¹ four washers removed from frame-side pivots to increase clearance for easier assembly.

INDEX

B

battery box 5-17

bed rails

- front/rear 8-1
- middle front 8-3
- middle rear 8-4
- pivot 8-8

blade guide arm 2-25

drive 2-23

blade guides

- drive side roller 2-12, 2-15, 2-18, 2-21
- idle side roller 2-1, 2-7, 2-10
- throat screw 4-1

blade tensioner 3-15

blade wheels

- drive side 3-1, 3-3, 3-5, 3-7
- idle side 3-9, 3-11, 3-13

brake assembly 4-12

C

clutch lever 4-2, 4-4, 4-10

Clutch/Brake Assembly (D33D42) 4-4

control box 5-1, 5-3

- circuit breakers 5-10
- drum switches 5-9
- front panel & harnesses 5-11

covers

- blade housing 4-16
 - drive belt 4-20
-

D

debarker wire box/hole plugs 4-23

decals

- frame 8-16
 - saw head 4-15
-

F

feed chain 7-6, 7-8

fuse box 5-19, 5-21

H

hydraulic

- control box 10-4, 10-7, 10-10
 - hoses 10-1, 10-3
 - log clamp 10-31, 10-33, 10-35
 - log loader 10-17, 10-19
 - log turner 10-21
 - power strip 10-13, 10-15
 - power strip (DC) 10-13
 - side supports 10-23, 10-26, 10-28
 - side supports (middle) 10-30
 - toe board 10-38
-

L

legs

- stationary 8-6
-

M

manuals 9-1

P

parts list

- how to use 1-1

power feed 7-4

- chain & stop 7-10
-

R

rest pin 8-15

S

sawdust chute 4-21

side supports 8-10, 8-12

T

track rollers

lower 7-12, 7-13

upper 7-1, 7-3

U

up/down

blade scales 6-3

chain & sprockets 6-5, 6-7, 6-9

drive (diesel) 6-13

drive (gas) 6-11

saw head mount 6-1

sprocket drive 6-11

W

water lube

bottle/tray 4-13