

Wood-Mizer[®] Sawmill

Safety, Setup, Operation & Maintenance Manual

LT30HD Super
LT40HD Super

rev. J7.01 - J8.09
rev. J7.01 - K3.02



Safety is our #1 concern! Read and understand all safety information and instructions before operating, setting up or maintaining this machine.

October 2004

Form #1183

Table of Contents

Section-Page

SECTION 1	INTRODUCTION	1-1
1.1	About This Manual.....	1-1
1.2	Getting Service.....	1-2
	<i>General Contact Information.....</i>	<i>1-2</i>
	<i>Branches & Authorized Sales Centers.....</i>	<i>1-3</i>
1.3	Specifications.....	1-5
1.4	Customer and Sawmill Identification.....	1-10
SECTION 2	SAFETY	2-1
2.1	Safety Symbols.....	2-1
2.2	Safety Instructions.....	2-2
SECTION 3	SAWMILL SETUP	3-1
3.1	Stationary Sawmill Setup.....	3-1
3.2	Portable Sawmill Setup.....	3-3
3.3	Replacing The Blade.....	3-7
3.4	Tensioning The Blade.....	3-8
3.5	Tracking The Blade.....	3-9
3.6	Starting The Engine (or Motor).....	3-11
3.7	Board Return.....	3-12
SECTION 4	SAWMILL OPERATION	4-1
4.1	Hydraulic Control Operation.....	4-1
4.2	Loading, Turning And Clamping Logs.....	4-3
4.3	Up/Down Operation.....	4-7
4.4	Blade Guide Arm Operation.....	4-8
4.5	Clutch/Brake Operation.....	4-9
4.6	Power Feed Operation.....	4-11
4.7	Cutting The Log.....	4-13
4.8	Edging.....	4-15
4.9	Optional Cutting Procedure for Super Series Mills.....	4-16
4.10	Blade Height Scale.....	4-17
4.11	Water Lube Operation.....	4-19
4.12	Preparing The Sawmill For Towing.....	4-21
SECTION 5	MAINTENANCE	5-1
5.1	Wear Life.....	5-1
5.2	Blade Guides.....	5-2
5.3	Sawdust Removal.....	5-6
5.4	Carriage Track, Wiper & Scrapers.....	5-7
5.5	Vertical Mast Rails.....	5-9

Table of Contents

Section-Page

5.6	Drum Switches	5-10
5.7	Miscellaneous	5-11
5.8	Blade Tensioner	5-13
5.9	Blade Wheel Belts	5-15
5.10	Brake Strap Adjustment	5-16
5.11	Drive Belt Adjustment.....	5-17
5.12	Hydraulic System	5-20
5.13	Drive Bearing	5-22
5.14	Up/Down System.....	5-23
5.15	Charging The Battery	5-26
5.16	Power Feed	5-28

MAINTENANCE LOG

5-31

SECTION 6 TROUBLESHOOTING GUIDE

6-1

6.1	Sawing Problems	6-1
6.2	Electrical Problems.....	6-3
6.3	Power Feed Problems	6-5
6.4	Power Feed Circuit Troubleshooting.....	6-7
	<i>LT30HD Super Rev. J8.00 - J8.09</i>	
	<i>LT40HD Super Rev. J8.00 - K3.02.....</i>	<i>6-7</i>
	<i>LT30HD Super Rev. J7.01 - J7.03</i>	
	<i>LT40HD Super Rev. J7.01 - J7.03.....</i>	<i>6-10</i>
6.5	Hydraulic Problems	6-12
6.6	Engine/Motor and Drive Pulleys Alignment.....	6-18
6.7	Power Feed Variable Feed Rate Switch Test	6-19
6.8	Power Feed Preliminary Test	6-20
6.9	Power Feed Mechanical Test.....	6-21
6.10	Hydraulic Pressure Test.....	6-22
6.11	Fuse Terminal Extension Stud.....	6-23
	<i>LT30HD Super Rev. J7.01 - J8.09</i>	
	<i>LT40HD Super Rev. J7.01 - K2.00.....</i>	<i>6-23</i>
6.12	Circuit Breaker Operation	6-25

Table of Contents

Section-Page

SECTION 7 SAWMILL ALIGNMENT

7-1

7.1 Routine Alignment Procedure7-1

- Blade Installation..... 7-1*
- Saw Head Tilt 7-2*
- Blade Guide Arm Alignment 7-4*
- Blade Guide Vertical Tilt Alignment..... 7-9*
- Blade Guide Horizontal Tilt Adjustment..... 7-11*
- Blade Guide Flange Spacing 7-14*
- Side Support Alignment..... 7-16*
- Blade Height Scale Adjustment..... 7-18*

7.2 Complete Alignment Procedure7-19

- Frame Setup 7-19*
- Blade Installation..... 7-20*
- Saw Head Slide Pad Adjustment..... 7-21*
- Blade Wheel Alignment..... 7-23*
- Track Roller Adjustment 7-28*
- Bed Rail Adjustment..... 7-31*
- Blade Guide Installation 7-33*
- Blade Guide Arm Alignment 7-37*
- Blade Guide Deflection..... 7-42*
- Blade Guide Vertical Tilt Alignment..... 7-44*
- Blade Guide Horizontal Tilt Adjustment..... 7-46*
- Blade Guide Flange Spacing 7-49*
- Blade Guide Level (Optional High-Performance blocks only)7-50*
- Blade Block Adjustment (Optional High-Performance blocks only)7-51*
- Side Support Alignment..... 7-52*
- Clamp Stop/Stop Bolt Adjustment..... 7-54*
- Saw Head Tilt 7-55*
- Blade Height Scale Adjustment..... 7-57*
- Board Return Bracket 7-58*

SECTION 8 HYDRAULIC INFORMATION

8-1

8.1 Hydraulic Schematic8-1

8.2 Hydraulic Layout Diagram.....8-2

8.3 Hydraulic Components8-3

8.4 Hydraulic Hoses8-4

INDEX

I

SECTION 1 INTRODUCTION

1.1 About This Manual

This manual is to replace or to be used with all previous information received on the Wood-Mizer® sawmill. All future mailings will be an addition to or a revision of individual sections of this manual as we obtain new information.

The information and instructions given in this manual do not amend or extend the limited warranties for the equipment given at the time of purchase.

For general information regarding Wood-Mizer and our “Forest to Final Form” products, please refer to the All Products Catalog in your support package.

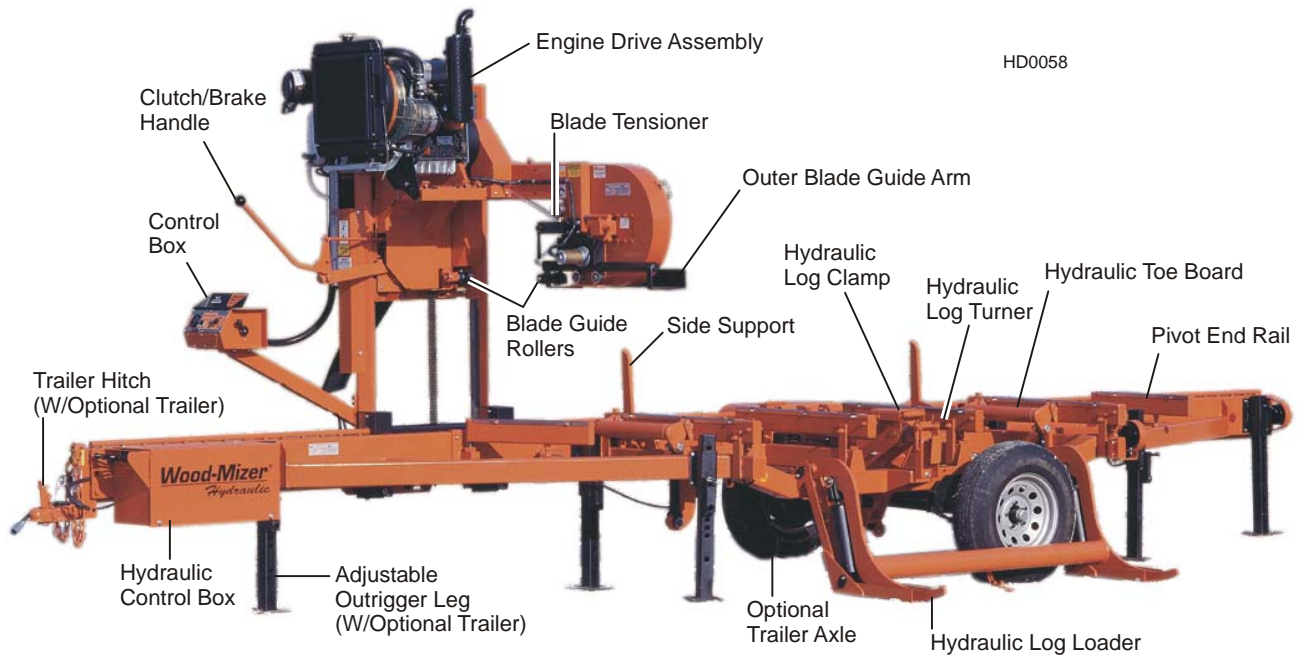

MILL COMPONENTS

*Wood-Mizer® is a registered trademark of Wood-Mizer Products, Inc.

1.2 Getting Service

Wood-Mizer is committed to providing you with the latest technology, best quality and strongest customer service available on the market today. We continually evaluate our customers' needs to ensure we're meeting current wood-processing demands. Your comments and suggestions are welcome.

General Contact Information

Toll free phone numbers are listed below for the *continental* U.S. and Canada. See the next page for contact information for specific Wood-Mizer locations.

	United States	Canada
Sales	1-800-553-0182	1-877-866-0667
Service	1-800-525-8100	1-877-866-0667
Website	www.woodmizer.com	www.woodmizer.ca
E-mail	woodmizer@woodmizer.com	oninfo@woodmizer.com

Office Hours: All times are Eastern Standard Time.

Monday - Friday	Saturday (Indianapolis Office Only)	Sunday
8 a.m. to 5 p.m.	8 a.m. to 12 p.m.	Closed

Please have your vehicle identification number and your customer number ready when you call.

Wood-Mizer will accept these methods of payment:

- Visa, Mastercard, or Discover
- COD
- Prepayment
- Net 15 (with approved credit)

Be aware that shipping and handling charges may apply. Handling charges are based on size and quantity of order. In most cases, items will ship on the day they are ordered. Second Day and Next Day shipping are available at additional cost.

If your sawmill was purchased outside the United States or Canada, contact the distributor for service.

Branches & Authorized Sales Centers

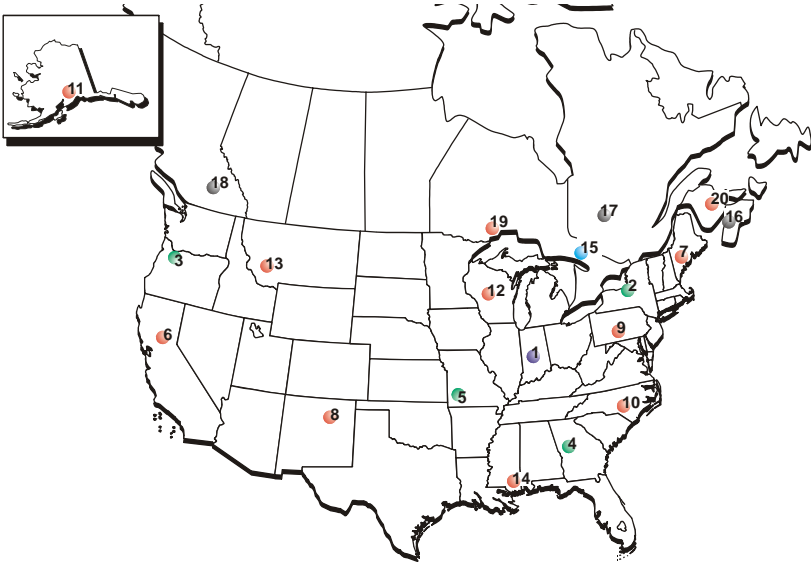

UNITED STATES

CANADA

1 World Headquarters
8180 W. 10th Street
Indianapolis, IN 46214-2400
Phone (317) 271-1542
Fax (317) 273-1011

15 Canadian Headquarters
217 Salem Road
Manilla, ON K0M 2J0
Phone (705) 357-3373
Fax (705) 357-3443

Wood-Mizer Branches

Authorized Sales Centers*

Wood-Mizer Canada Branches

2 Wood-Mizer Northeast
8604 State Route 104
Hannibal, NY 13074
Phone (315) 564-5722
Fax (315) 564-7160

6 California
6980 Camp Far West Road
Sheridan, CA 95681
Phone (530) 633-4316
Fax (530) 533-2818
E-mail fwfp@psyber.com

16 Wood-Mizer Canada East
Box 173, 1082 #1 Hwy
Aylesford, NS B0P 1C0
Phone/Fax (902) 847-9369

3 Wood-Mizer Portland
24435 N.E. Sandy Blvd.
Wood Village, OR 97060
Phone (503) 661-1939
Fax (503) 667-2961

7 Maine
541 Borough Road
Chesterville, ME 04938
Phone (207) 645-2072
Fax (207) 645-3786
E-mail woodmzer@megalink.net

17 Wood-Mizer Canada Quebec
422 Rte. du Canton (Rte. 148)
Chatham, QC J8G 1R1
Phone (450) 562-2414
Fax (450) 562-0314

4 Wood-Mizer South
74 Pine Road
Newnan, GA 30263-5141
Phone (770) 251-4894
Fax (770) 251-4896

8 New Mexico
425 Bibb Industrial Drive
Las Vegas, NM 87701
Phone (888) 545-9663
Fax (505) 454-6008
E-mail djold@earthlink.net

18 Wood-Mizer Canada West
4770 46th Avenue S.E.
Salmon Arm, BC V1E 2W1
Phone (250) 833-1944
Fax (250) 833-1945

1

Introduction

Branches & Authorized Sales Centers

5 Wood-Mizer Missouri

9664 Lawrence 2130
N.Mt. Vernon, MO 65712
Phone (417) 466-9500
Fax (417) 471-1327

9 Pennsylvania

HCR 75 (Off Old Road 522)
Shade Gap, PA 17255
Phone (814) 259-9976
Fax (814) 259-3016
E-mail parsons@innernet.net

10 North Carolina

28002 Canton Road
Albemarle, NC 28001
Phone (704) 982-1673
Fax (704) 982-1619
E-mail carolina@woodmizer.com

11 Alaska

HCO5 9821
Palmer, AK 99645
Phone (907) 746-3030
Fax (907) 745-0508
E-mail mvmiling@mtaonline.net

12 Wisconsin

2201 Highway O
Mosinee, WI 54455
Phone (715) 693-1929
E-mail dsclass@dwave.net

13 Montana

51 Basin Creek Road
Basin, MT 59631
Phone (406) 225-4362
Fax (207) 645-3786
E-mail rockymountainwoodmizer@yahoo.com

14 Mississippi

123 Cable Bridge Road
Perkinston, MS 39573
Phone (601) 928-3022

Authorized Sales Centers*

19 Ontario North

41 Rubin Drive
Murillo, ON P0T 2T0
Phone (807) 683-9243
Fax (807) 767-1123

20 East New Brunswick

161 Ave. De L'Eglise
St. Antoine, NB E4V 1M2
Phone (506) 525-1007
Fax (506) 525-2913

*Authorized Sales Centers offer limited services such as sawmill demos and training, routine service and sales of blades and common replacement parts

1.3 Specifications

Model: **LT30HD Super Rev. J8.07 - J8.09**

Dimensions:

Length: 21'-11"
 Width: 6'-6"
 Height (Ground To Mast): 7'-8"
 Height (Max Head Position): 11'-0"
 Bed Height (Ground To Bed): 31"

Weights:	G36	E25	D42	D51
Basic Unit (Wet):	3505 lbs	3246 lbs	3425 lbs	3450 lbs
With Trailer:	3930 lbs	3671 lbs	3850 lbs	3900 lbs
Tongue Weight:		136 lbs	130 lbs	

Trailer:

Axle Capacity: 5080 lbs
 Tire Capacity: 2540 lbs
 Tire Size: ST225/75R15
 Weight: 425 lbs

Log Capacity:

Length: 16'-8"
 Length (w/Operator Seat Option): 14'-8"
 Diameter: 36"
 Weight: 4400 lbs
 Max Clamp Width (from stop block): 26"
 Max Throat Width (guide to guide): 28"
 Max Cant Width (outer guide to stop block): 25"

Engine:	G36	E25	D42	D51
Manufacturer:	Nissan	Lincoln	Kubota	Caterpillar
Fuel:	Gas	Electric	Diesel	Diesel
Horsepower Rating:	36	25	42	51
Weight:	350 lbs	235 lbs	435 lbs	485
Idle Speed:	1500 RPM	3600 RPM	1500 RPM	1500 RPM
High Throttle Speed (No Load):	3600 RPM	3600 RPM	3200 RPM	3100 RPM
Noise Level - @ operator position:	83 dBA	98 dBA	98 dBA	92 dBA
Noise Level - 20 feet away:	67 dBA	90 dBA	87 dBA	84 dBA
Blade Speed (No Load):	5700 sfpm	5800 sfpm	5700 sfpm	sfpm
Fuel Consumption (per hour):	1.0 Gal.	20 KwHr	1 Gal.	1.5 gal
Cooling System:	Water	Air	Water	Water
Coolant Capacity:	1.65 Gal.		1.75 Gal.	
Drive Shaft O.D.:	1 7/16"	1 5/8"	1 7/16"	1 7/16"
Drive Pulley:	4.15"	4TB38	3TB42	4.46"
Drive Belt:	3/5v750	3/5v750	3/5v750	3/5VFL770
Blade Braking:	1 Second	1 Second	1 Second	1 Second
Oil Capacity w/Filter:	4 qts.	N/A	6.7 qts.	10 qts.
Battery:	12V 1125CCA	12V 1125CCA	12V 1125CCA	12V 1125CCA
Alternator Output:	140 Amp	140 Amp	140 Amp	140 Amp
Alternator Belt:	6PK425	6PK425	6PK425	6PK1055

Rates:

Forward (no cutting):	180 ft./min.			
Reverse:	200 ft./min.			
Up (24"):	13.7 sec.	10.5 sec.	11.3 sec.	10.5 sec.
Down (24"):	7.7 sec.	7.0 sec.	6.9 sec.	6.6 sec.
Hourly Production (Average range w/experienced operators/average size logs):	400-600 bdf.			

Options:

Single/Lap Siding Option:	143 lbs
Debarker:	69 lbs
Resaw Attachment:	231 lbs
Laser Sight:	2.5 lbs
Accuset:	13 lbs
6' Bed Extension:	390 lbs
12' Bed Extension:	758 lbs
24' Bed Extension:	1122 lbs
Operator Seat:	112 lbs
	±1/32" per drop

1 Introduction

Specifications

Model: LT30HD Super Rev. H8.00 - J8.06

Dimensions:

Length: 21'-11"
 Width: 6'-6"
 Height (Ground To Mast): 7'-8"
 Height (Max Head Position): 11'-0"
 Bed Height (Ground To Bed): 31"

Weights:	G36	E25	D42	D51
Basic Unit (Wet):	3505 lbs	3246 lbs	3425 lbs	3450 lbs
With Trailer:	3930 lbs	3671 lbs	3850 lbs	3900 lbs
Tongue Weight:		136 lbs	130 lbs	

Trailer:

Axle Capacity: 5080 lbs
 Tire Capacity: 2540 lbs
 Tire Size: ST225/75R15
 Weight: 425 lbs

Log Capacity:

Length: 16'-8"
 Length (w/Operator Seat Option): 14'-8"
 Diameter: 36"
 Weight: 4400 lbs
 Max Clamp Width (from stop block): 26"
 Max Throat Width (guide to guide): 28"
 Max Cant Width (outer guide to stop block): 25"

Engine:	G36	E25	D42	D51
Manufacturer:	Nissan	Lincoln	Kubota	Caterpillar
Fuel:	Gas	Electric	Diesel	Diesel
Horsepower Rating:	36	25	42	51
Weight:	350 lbs	235 lbs	435 lbs	485 lbs
Idle Speed:	1500 RPM	3600 RPM	1500 RPM	1500 RPM
High Throttle Speed (No Load):	3600 RPM	3600 RPM	3200 RPM	3100 RPM
Noise Level - @ operator position:	83 dBA	98 dBA	98 dBA	92 dBA
Noise Level - 20 feet away:	67 dBA	90 dBA	87 dBA	84 dBA
Blade Speed (No Load):	5700 sfpm	5800 sfpm	5700 sfpm	sfpm
Fuel Consumption (per hour):	1.0 Gal.	20 KwHr	1 Gal.	1.5 gal
Cooling System:	Water	Air	Water	Water
Coolant Capacity:	1.65 Gal.		1.75 Gal.	
Drive Shaft O.D.:	1 7/16"	1 5/8"	1 7/16"	1 7/16"
Drive Pulley:	4.15"	4TB38	3TB42	4.46"
Drive Belt:	3/5v750	3/5v750	3/5v750	3/5VFL770
Blade Braking:	1 Second	1 Second	1 Second	1 Second
Oil Capacity w/Filter:	4 qts.	N/A	6.7 qts.	10 qts.
Battery:	12V 1125CCA	12V 1125CCA	12V 1125CCA	12V 1125CCA
Alternator Output:	140 Amp	140 Amp	140 Amp	140 Amp
Alternator Belt:	6PK425	6PK425	6PK425	6PK1055

Rates:

Forward (no cutting): 180 ft./min.
 Reverse: 200 ft./min.
 Up (24"): 17.3 sec. 13.3 sec. 14.3 sec. 13.3 sec.
 Down (24"): 10.6 sec. 9.7 sec. 9.5 sec. 9.0 sec.

Hourly Production (Average range w/experienced operators/average size logs): 400-600 bdf.

Options:

Single/Lap Siding Option: 143 lbs
 Debarker: 69 lbs
 Resaw Attachment: 231 lbs
 Laser Sight: 2.5 lbs
 Accuset: 13 lbs ±1/32" per drop
 6' Bed Extension: 390 lbs
 12' Bed Extension: 758 lbs
 24' Bed Extension: 1122 lbs

Model: LT40HD Super Rev. K1.00+

Dimensions:

Length: 26'-2"
 Width: 6'-6"
 Height (Ground To Mast): 7'-8"
 Height (Max Head Position): 11'-0"
 Bed Height (Ground To Bed): 31"

Weights:	D47	E25	G38	D51
Basic Unit (Wet):	3564 lbs	3446 lbs	3343 lbs	3675 lbs
With Trailer:	3989 lbs	3871 lbs	3768 lbs	4100 lbs
Tongue Weight:		128 lbs		

Trailer:

Axle Capacity: 5080 lbs
 Tire Capacity: 2540 lbs
 Tire Size: ST225/75R15
 Weight: 425 lbs

Log Capacity:

Length: 21'-0"
 Length (w/Operator Seat Option): 19'-0"
 Diameter: 36"
 Weight: 4400 lbs
 Max Clamp Width (from stop block): 26"
 Max Throat Width (guide to guide): 28"
 Max Cant Width (outer guide to stop block): 25"

Engine:	D47	E25	G38	D51
Manufacturer:	Yanmar	Lincoln	Kohler	Caterpillar
Fuel:	Diesel	Electric	Gas	Diesel
Horsepower Rating:	47.5	25	38	51
Weight:	374 lbs	235 lbs	132 lbs	485 lbs
Idle Speed:	1500 RPM	3600 RPM	1200 RPM	1500 RPM
High Throttle Speed (No Load):	3000 RPM	3600 RPM	3600 RPM	3100 RPM
Noise Level - @ operator position:		98 dBA		92 dBA
Noise Level - 20 feet away:		90 dBA		84 dBA
Blade Speed (No Load):		5800 sfpm		sfpm
Fuel Consumption (per hour):		20 KwHr		1.5 gal
Cooling System:	Water	Air	Air	Water
Coolant Capacity:				
Drive Shaft O.D.:	1 7/16"	1 5/8"	1 7/16"	1 7/16"
Drive Pulley:	4.46"	4TB38	4.06"	4.46"
Drive Belt:	3/5VFL770	3/5v750	3/5v750	3/5VFL770
Blade Braking:	1 Second	1 Second		1 Second
Oil Capacity w/Filter:	7.8 qts.	N/A	2.9 qts.	10 qts.
Battery:	12V 1125CCA	12V 1125CCA	12V 1125CCA	12V 1125CCA
Alternator Output:	140 Amp	140 Amp	140 Amp	140 Amp
Alternator Belt:	6PK1145	6PK425	6PK425	6PK1055

Rates:

Forward (no cutting): 180 ft./min.
 Reverse: 200 ft./min.
 Up (24"): 10.5 sec.
 Down (24"): 7.0 sec.
 10.5 sec.
 6.6 sec.

Hourly Production (Average range w/experienced operators/average size logs): up to 550 bdf.

Options:

Single/Lap Siding Option: 143 lbs
 Debarker: 69 lbs
 Resaw Attachment: 231 lbs
 Laser Sight: 2.5 lbs
 Accuset 2: 13 lbs ±1/32" per drop
 6' Bed Extension: 390 lbs
 12' Bed Extension: 758 lbs
 24' Bed Extension: 1122 lbs
 Operator Seat: 112 lbs

1 Introduction

Specifications

Model: LT40HD Super Rev. J8.07 - J9.02

Dimensions:

Length: 26'-2"
 Width: 6'-6"
 Height (Ground To Mast): 7'-8"
 Height (Max Head Position): 11'-0"
 Bed Height (Ground To Bed): 31"

Weights:	G36	E25	G38	D42	D51
Basic Unit (Wet):	3710 lbs	3446 lbs		3625 lbs	3675
With Trailer:	4135 lbs	3871 lbs		4050 lbs	4100
Tongue Weight:		128 lbs		82 lbs	

Trailer:

Axle Capacity: 5080 lbs
 Tire Capacity: 2540 lbs
 Tire Size: ST225/75R15
 Weight: 425 lbs

Log Capacity:

Length: 21'-0"
 Length (w/Operator Seat Option): 19'-0"
 Diameter: 36"
 Weight: 4400 lbs
 Max Clamp Width (from stop block): 26"
 Max Throat Width (guide to guide): 28"
 Max Cant Width (outer guide to stop block): 25"

Engine:	G36	E25	G38	D42	D51
Manufacturer:	Nissan	Lincoln	Kohler	Kubota	Caterpillar
Fuel:	Gas	Electric	Gas	Diesel	Diesel
Horsepower Rating:	36	25	38	42	51
Weight:	350 lbs	235 lbs	132 lbs	435 lbs	485 lbs
Idle Speed:	1500 RPM	3600 RPM	1200 RPM	1500 RPM	1500 RPM
High Throttle Speed (No Load):	3600 RPM	3600 RPM	3600 RPM	3200 RPM	3100 RPM
Noise Level - @ operator position:	83 dBA	98 dBA		98 dBA	92 dBA
Noise Level - 20 feet away:	67 dBA	90 dBA		87 dBA	84 dBA
Blade Speed (No Load):	5700 sfpm	5800 sfpm		5700 sfpm	
Fuel Consumption (per hour):	1.0 Gal.	20 KwHr		1 Gal.	1.5 gal
Cooling System:	Water	Air	Air	Water	Water
Coolant Capacity:	1.65 Gal.			1.75 Gal.	
Drive Shaft O.D.:	1 7/16"	1 5/8"	1 7/16"	1 7/16"	1 7/16"
Drive Pulley:	4.15"	4TB38	4.06"	3TB42	4.46"
Drive Belt:	3/5v750	3/5v750	3/5v750	3/5v750	3/5VFL770
Blade Braking:	1 Second	1 Second		1 Second	1 Second
Oil Capacity w/Filter:	4 qts.	N/A	2.9 qts.	6.7 qts.	10 qts.
Battery:	12V 1125CCA	12V 1125CCA	12V 1125CCA	12V 1125CCA	12V 1125CCA
Alternator Output:	140 Amp	140 Amp	140 Amp	140 Amp	140 Amp
Alternator Belt:	6PK425	6PK425	6PK425	6PK425	6PK1055

Rates:

Forward (no cutting): 180 ft./min.
 Reverse: 200 ft./min.
 Up (24"): 13.7 sec.
 Down (24"): 7.7 sec.

10.5 sec.	11.3 sec.	13.3 sec.
7.0 sec.	6.9 sec.	9.0 sec.

Hourly Production (Average range w/experienced operators/average size logs): 400-600 bdf.

Options:

Single/Lap Siding Option: 143 lbs
 Debarker: 69 lbs
 Resaw Attachment: 231 lbs
 Laser Sight: 2.5 lbs
 Accuset: 13 lbs ±1/32" per drop
 6' Bed Extension: 390 lbs
 12' Bed Extension: 758 lbs
 24' Bed Extension: 1122 lbs
 Operator Seat: 112 lbs

Model: LT40HD Super Rev. H8.00 - J8.06

Dimensions:

Length: 26'-2"
 Width: 6'-6"
 Height (Ground To Mast): 7'-8"
 Height (Max Head Position): 11'-0"
 Bed Height (Ground To Bed): 31"

Weights:	G36	E25	D42	D51
Basic Unit (Wet):	3710 lbs	3446 lbs	3625 lbs	3675 lbs
With Trailer:	4135 lbs	3871 lbs	4050 lbs	4100 lbs
Tongue Weight:		128 lbs	82 lbs	

Trailer:

Axle Capacity: 5080 lbs
 Tire Capacity: 2540 lbs
 Tire Size: ST225/75R15
 Weight: 425 lbs

Log Capacity:

Length: 21'-0"
 Length (w/Operator Seat Option): 19'-0"
 Diameter: 36"
 Weight: 4400 lbs
 Max Clamp Width (from stop block): 26"
 Max Throat Width (guide to guide): 28"
 Max Cant Width (outer guide to stop block): 25"

Engine:	G36	E25	D42	D51
Manufacturer:	Nissan	Lincoln	Kubota	Caterpillar
Fuel:	Gas	Electric	Diesel	Diesel
Horsepower Rating:	36	25	42	51
Weight:	350 lbs	235 lbs	435 lbs	485 lbs
Idle Speed:	1500 RPM	3600 RPM	1500 RPM	1500 RPM
High Throttle Speed (No Load):	3600 RPM	3600 RPM	3200 RPM	3100 RPM
Noise Level - @ operator position:	83 dBA	98 dBA	98 dBA	92 dBA
Noise Level - 20 feet away:	67 dBA	90 dBA	87 dBA	84 dBA
Blade Speed (No Load):	5700 sfpm	5800 sfpm	5700 sfpm	
Fuel Consumption (per hour):	1.0 Gal.	20 KwHr	1 Gal.	1.5 gal
Cooling System:	Water	Air	Water	Water
Coolant Capacity:	1.65 Gal.		0 1.75 Gal.	
Drive Shaft O.D.:	1 7/16"	1 5/8"	1 7/16"	1 7/16"
Drive Pulley:	4.15"	4TB38	3TB42	4.46"
Drive Belt:	3/5v750	3/5v750	3/5v750	3/5VFL770
Blade Braking:	1 Second	1 Second	1 Second	1 Second
Oil Capacity w/Filter:	4 qts.	N/A	6.7 qts.	10 qts.
Battery:	12V 1125CCA	12V 1125CCA	12V 1125CCA	12V 1125CCA
Alternator Output:	140 Amp	140 Amp	140 Amp	140 Amp
Alternator Belt:	6PK425	6PK425	6PK425	6PK1055

Rates:

Forward (no cutting): 180 ft./min.
 Reverse: 200 ft./min.
 Up (24"): 17.3 sec. 13.3 sec. 14.3 sec. 13.3 sec.
 Down (24"): 10.6 sec. 9.7 sec. 9.5 sec. 9.0 sec.

Hourly Production (Average range w/experienced operators/average size logs): 400-600 bdf.

Options:

Single/Lap Siding Option: 143 lbs
 Debarker: 69 lbs
 Resaw Attachment: 231 lbs
 Laser Sight: 2.5 lbs
 Accuset: 13 lbs ±1/32" per drop
 6' Bed Extension: 390 lbs
 12' Bed Extension: 758 lbs
 24' Bed Extension: 1122 lbs



Introduction

Customer and Sawmill Identification

1.4 Customer and Sawmill Identification

Each Wood-Mizer sawmill has a model number and a 17-digit Vehicle Identification Number (VIN). In addition, when you pick up your mill, you will receive a customer number. These three numbers will help expedite our service to you. Please locate them now and write them below so you have quick, easy access to them. See the following figures for model number and V.I.N. descriptions and locations.

(To be filled in by purchaser)

Mill Model _____
 Mill VIN _____
 Customer No. _____

LT40HD
 Basic Sawmill I.D.

D51
 Engine/Motor Configuration

-H
 Hydrostatic Feed & Up/Down

MODEL NUMBER DESCRIPTION

See below for a description of the V.I.N.

Company Identification Number 456=Wood-Mizer Indiana	Weight Class; A=Under 3,000 lbs B=3,001-4,000 lbs C=4,001-5,000 lbs D=5,001-6,000 lbs	Product No.; 2=LT28, 3=LT30/40, 4=LT30HD/40HD, 5=LT/40 Super, 6=LT40HD Super, 7=LT60HD/70HD, 8=LT50HD	Length of the Trailer; 20=20 Ft., 24=24', 35=35'	Number of axles on the trailer	Check Digit Add all the numbers and divide by 11	Year of Manufacture; X=1999, Y=2000, 1=2001, 2=2002, 3=2003, etc...	State of Manufacture N=Indiana, P=Poland	Month of Manufacture A=January, B=February, C=March, etc...	Revision Level	Sequence Number Ranging from 000-999	End of 17-Digit VIN	Revision Level (Repeated)	Two-Digit Minor Revision Level
456	A	5	24	1	X	S	N	A	F9	017		F9	.01

V.I.N. DESCRIPTION.

The model number and V.I.N. can be found in the following locations.

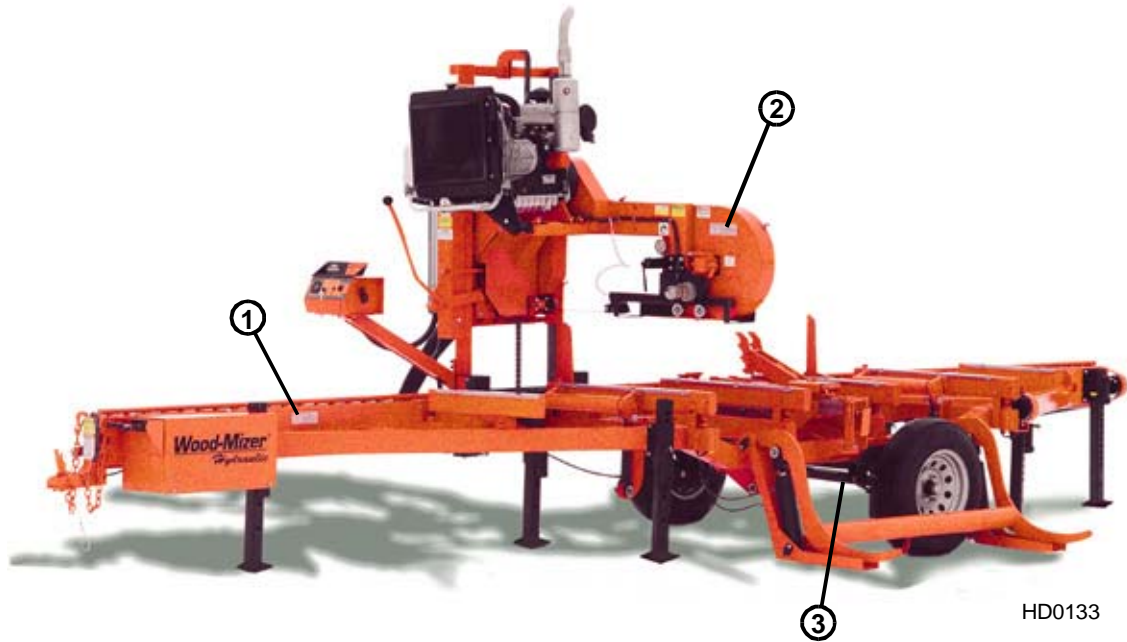



MODEL NUMBER AND V.I.N. LOCATIONS

SECTION 2 SAFETY

2.1 Safety Symbols

The following symbols and signal words call your attention to instructions concerning your personal safety. Be sure to observe and follow these instructions.

 **DANGER!** indicates an imminently hazardous situation which, if not avoided, will result in death or serious injury.

 **WARNING!** suggests a potentially hazardous situation which, if not avoided, could result in death or serious injury.

 **CAUTION!** refers to potentially hazardous situations which, if not avoided, may result in minor or moderate injury or damage to equipment.

 **IMPORTANT!** indicates vital information.

NOTE: gives helpful information.

 Warning stripes are placed on areas where a single decal would be insufficient. To avoid serious injury, keep out of the path of any equipment marked with warning stripes.

2.2 Safety Instructions

NOTE: ONLY safety instructions regarding personal injury are listed in this section. Caution statements regarding only equipment damage appear where applicable throughout the manual.

OBSERVE SAFETY INSTRUCTIONS



IMPORTANT! Read the entire Operator's Manual before operating the sawmill. Take notice of all safety warnings throughout this manual and those posted on the machine. Keep this manual with this machine at all times, regardless of ownership.

Also read any additional manufacturer's manuals and observe any applicable safety instructions including dangers, warnings, and cautions.

Only persons who have read and understood the entire operator's manual should operate the sawmill. The sawmill is not intended for use by or around children.

IMPORTANT! It is always the owner's responsibility to comply with all applicable federal, state and local laws, rules and regulations regarding the ownership, operation and towing of your Wood-Mizer sawmill. All Wood-Mizer mill owners are encouraged to become thoroughly familiar with these applicable laws and comply with them fully while using or towing the mill.



WEAR SAFETY CLOTHING



WARNING! Secure all loose clothing and jewelry before operating the sawmill. Failure to do so may result in serious injury or death.

WARNING! Always wear gloves and eye protection when handling bandsaw blades. Changing blades is safest when done by one person! Keep all other persons away from area when coiling, carrying or changing a blade. Failure to do so may result in serious injury.

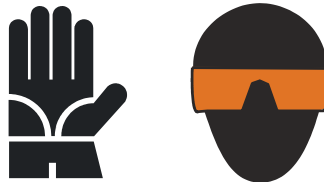

WARNING! Always wear eye, ear, respiration, and foot protection when operating or servicing the sawmill.



KEEP SAWMILL AND AREA AROUND SAWMILL CLEAN



DANGER! Maintain a clean and clear path for all necessary movement around the mill and lumber stacking areas. Failure to do so will result in serious injury.

HANDLE FUEL/LUBRICANTS SAFELY



DANGER! Due to the flammable nature of fuel and oil, never smoke, weld, grind or allow sparks near your engine or storage tanks, especially during times of fueling.

DANGER! Never allow fuel to spill on a hot engine during fueling operations or otherwise. The hot temperature of your engine could induce a fire or explosion.



WARNING! Store gasoline away from sawdust and other flammable materials. Failure to do so may result in serious injury.



WARNING! Use ONLY water and Wood-Mizer Lube Additive with the water lube accessory. Never use flammable fuels or liquids such as diesel fuel. If these types of liquids are necessary to clean the blade, remove it and clean with a rag. Failure to do so can damage the equipment and may result in serious injury or death.

WARNING! Drum switch grease contains Petroleum Hydrocarbon Lubricant. Eye and skin irritant. If introduced into eyes, flush with water for at least 15 minutes. If film or irritation persists, seek medical attention. Wash skin with soap and water. If ingested, do not induce vomiting - contact a physician. KEEP OUT OF THE REACH OF CHILDREN.

DISPOSE OF SAWING BY-PRODUCTS PROPERLY



IMPORTANT! Always properly dispose of all sawing by-products, including sawdust and other debris, coolant, oil, fuel, oil filters and fuel filters.

USE CAUTION WHEN WORKING WITH BATTERIES

DANGER! Batteries expel explosive gases. Keep sparks, flames, burning cigarettes, or other ignition sources away at all times. Always wear safety goggles and a face shield when working near batteries. Failure to do so will cause serious injury. ¹



WARNING! Battery posts, terminals and related accessories contain lead and lead compounds, chemicals known to the State of California to cause cancer and reproductive harm. Wash hands after handling.



WARNING! Charge the battery in a well ventilated area. Do not attempt to charge a frozen battery.

Use extreme care to avoid spilling or splashing electrolyte (which is dilute sulfuric acid) as it can destroy clothing and burn the skin. If electrolyte is spilled or splashed on clothing or the body, it should be neutralized immediately and then rinsed with clean water. A solution of baking soda, or household ammonia, and water may be used as a neutralizer.

Electrolyte splashed into the eyes is extremely dangerous. If this should happen, force the eye open and flood it with cool, clean water for approximately fifteen minutes. A doctor should be called immediately when the accident occurs and “on-the-spot” medical attention given if possible. If a doctor cannot come to the scene of the accident immediately, follow his instructions concerning actions to take. Do not add eye drops or other medication unless advised to do so by the doctor. Do not place a battery or acid within the reach of children. If acid (electrolyte) is taken internally drink large quantities of water or milk. Follow with milk of magnesia, beaten egg or vegetable oil. Call a physician immediately.

If electrolyte is spilled or splashed on any surface of the machine, it should be neutralized and rinsed with clean water.



CAUTION! Do not overcharge the battery. Overcharging may reduce the overall service life of the battery.

CAUTION! Be sure the battery is fully charged before transporting the sawmill. If the battery is not fully charged, excessive vibration could reduce the overall service life of the battery.

¹ Battery Council International, copyright 1987

CAUTIONS FOR SAWMILL SETUP



WARNING! Do not set up the mill on ground with more than a 10 degree incline. If setup on an incline is necessary, put blocks under one side of the mill or dig out areas for the outrigger legs to keep mill level. Setting up the mill on an incline could cause it to tip over, resulting in serious personal injury.

WARNING! Chock the trailer wheels to prevent movement before unhitching it from the towing vehicle. Failure to do so may result in serious injury or death.

WARNING! Put front outrigger down before moving saw head from the rest position. Failure to do so may result in serious injury.

WARNING! Always make sure the trailer is supporting the sawmill frame when operating a sawmill with adjustable outriggers. Failure to do so may result in serious injury or death. The adjustable outriggers are intended to support the saw frame with assistance from the trailer.

WARNING! The adjustable outriggers supplied with portable sawmills are not intended for setup on concrete or other hard surfaces. Long-term use of the adjustable outriggers on hard surfaces may cause the outriggers to fail, causing the sawmill to drop. This could result in possible serious injury or death.

If setting the sawmill up on concrete or other hard surface, replace the adjustable outrigger legs with stationary legs.

WARNING! Securely fasten the feet of a stationary sawmill to the floor before operating the sawmill. Failure to do so may result in serious injury or death.

CHECK SAWMILL BEFORE OPERATION

 **DANGER!** Make sure all guards and covers are in place and secured before operating or towing the sawmill. Failure to do so may result in serious injury.

Be sure the blade housing and pulley covers are in place and secure. Use the safety retainer pin and cable to fasten blade housing covers.



KEEP PERSONS AWAY



DANGER! Stay clear of the area between the trailer axle and saw carriage. Failure to do so will result in serious injury.



DANGER! Keep all persons out of the path of moving equipment and logs when operating sawmill or loading and turning logs. Failure to do so will result in serious injury.

DANGER! Always be sure the blade is disengaged and all persons are out of the path of the blade before starting the engine or motor. Failure to do so will result in serious injury.

KEEP HANDS AWAY

DANGER! Always disengage the blade and shut off the sawmill engine before changing the blade. Failure to do so will result in serious injury.

DANGER! Engine components can become very hot during operation. Avoid contact with any part of a hot engine. The exhaust components of your engine are especially hot during and following operation. Contact with hot engine components can cause serious burns. Therefore, never touch or perform service functions on a hot engine. Allow the engine to cool sufficiently before beginning any service function.

DANGER! Always keep hands away from moving bandsaw blade. Failure to do so will result in serious injury.

DANGER! Always be aware of and take proper protective measures against rotating shafts, pulleys, fans, etc. Always stay a safe distance from rotating members and make sure that loose clothing or long hair does not engage rotating members resulting in possible injury.



WARNING! Do not spin the blade wheels by hand. Spinning the blade wheels by hand may result in serious injury.

WARNING! Always disengage the clutch/brake mechanism whenever the sawmill is not cutting. Failure to do so may result in serious injury.

WARNING! Do not for any reason adjust the engine drive belts or belt support bracket with the engine running. Doing so may result in serious injury.

WARNING! Always keep clear of exiting sawdust. Keep hands, feet and any other objects away from the sawdust chute when operating sawmill. Failure to do so may result in serious injury.

CAUTIONS FOR GAS OR DIESEL ENGINE OPERATION



DANGER! Operate your engine/machine only in well ventilated areas. The exhaust gases of your engine can cause nausea, delirium and potentially death unless adequate ventilation is present.

DANGER! Never operate an engine with a fuel or oil leak. The leaking fuel or oil could potentially come in contact with hot surfaces and ignite into flames.

WARNING! Do not operate engine without proper and operational spark arrester/muffler. Sparks emitted from the engine exhaust could ignite surrounding materials, causing serious injury or death.

USE PROPER PROCEDURE WHEN CONDUCTING ELECTRICAL SAFETY CHECKS AND MAINTENANCE

 **DANGER!** Make sure all electrical installation, service and/or maintenance work is performed by a qualified electrician and is in accordance with applicable electrical codes.

DANGER! ARC FLASH AND SHOCK HAZARD! Hazardous voltage inside the electric sawmill disconnect box, starter box, and at the motor can cause shock, burns, or death. Disconnect and lock out power supply before servicing! Keep all electrical component covers closed and securely fastened during mill operation. Wear appropriate Personal Protection Equipment.

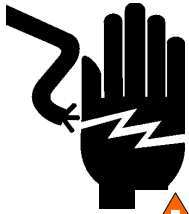

WARNING! Consider all electrical circuits energized and dangerous.

WARNING! Disconnect the negative battery terminal cable before performing any service to the 12-Volt electrical system. Failure to do so may result in injury and/or electrical system damage.

WARNING! Never assume or take the word of another person that the power is off; check it out and lock it out.

WARNING! Do not wear rings, watches, or other jewelry while working around an open electrical circuit.

WARNING! Before performing service near moving parts such as blades, pulleys, motors, belts and chains, first turn the key switch to the OFF (#0) position and remove the key. If the key is turned on and moving parts activated, serious injury may result.

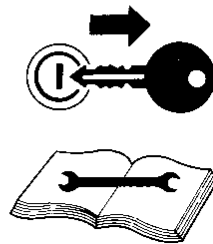

WARNING! Remove the blade before performing any service to the engine or sawmill. Failure to do so may result in serious injury.

DANGER! Lockout procedures must be used during:

- Changing or adjusting blades
- Unjamming operations
- Cleaning
- Mechanical repair
- Electrical maintenance
- Retrieval of tools/parts from work area
- Activities where guards or electrical panel guard is open or removed

Maintenance hazards include:

- Blade contact
- Pinch points
- Kickbacks
- Missiles (thrown blades/wood chips)
- Electrical

Failure to lockout may result in:

- Cut
- Crush
- Blindness
- Puncture
- Serious injury and death
- Amputation
- Burn
- Shock
- Electrocution

To control maintenance dangers:

Lockout procedures must be followed (see ANSI Standard Z244.1-1982 and OSHA regulation 1910.147).

Never rely on machine stop control for maintenance safety (emergency stops, on/off buttons, interlocks).

Do not reach into moving blades or feed systems. Allow all coasting parts to come to a complete stop.

Electrical power supply and air supply must both be locked out.

Where established lockout procedures cannot be used (electrical troubleshooting or mechanical dynamic troubleshooting), alternative effective protective techniques shall be employed which may require special skills and planning.

Always follow safe operations practices in the workplace.

SAWMILL LOCKOUT PROCEDURE

Lockout procedures must be followed (see ANSI Standard Z244.1-1982 and OSHA regulation 1910.147).

Purpose:

This procedure establishes the minimum requirements for lockout of energy sources that could cause injury.

Responsibility:

The responsibility for seeing that this procedure is followed is binding upon all workers. All workers shall be instructed in the safety significance of the lockout procedure. It is your responsibility to ensure safe operation of the machine.

Preparation For Lockout:

Sawmill must be locked out both electrically and pneumatically (lockout air valve).

Sequence of Lockout Procedure:

1. Notify all persons that a lockout is required and the reason therefore.
2. If the Sawmill is operating, shut it down by the normal stopping procedure.
3. Operate the switch and valve so that the energy sources are disconnected or isolated from the Sawmill. Stored energy such as moving blades, feed system and air pressure shall be dissipated.
4. Lockout the energy isolating devices with assigned individual locks.
5. After ensuring that no persons are exposed and as a check on having disconnected the energy sources, operate the push button or other normal operating controls to make certain the Sawmill will not operate. Caution: Return operating controls to neutral position after the test.
6. The Sawmill is now locked out.

Restoring Equipment to Service

1. When the job is complete and the Sawmill is ready for testing or normal service, check the Sawmill area to see that no one is exposed.
2. When the Sawmill is all clear, remove all locks. The energy isolating devices may be operated to restore energy to the Sawmill.

Procedure Involving More Than One Person

In the preceding steps, if more than one individual is required to lock out the Sawmill, each shall place his own personal lock on the energy isolating devices.

Rules for Using Lockout Procedure

The Sawmill shall be locked out to protect against accidental or inadvertent operation when such operation could cause injury to personnel. Do not attempt to operate any switch or valve bearing a lock.

Owner's Responsibility

The procedures listed in this manual may not include all ANSI, OSHA, or locally required safety procedures. It is the owner/operator's responsibility and not Wood-Mizer Products to ensure all operators are properly trained and informed of all safety protocols. Owner/Operators are responsible for following all safety procedures when operating and performing maintenance to the Sawmill.

KEEP SAFETY LABELS IN GOOD CONDITION



IMPORTANT! Always be sure that all safety decals are clean and readable. Replace all damaged safety decals to prevent personal injury or damage to the equipment. Contact your local distributor, or call your Customer Service Representative to order more decals.



IMPORTANT! If replacing a component which has a safety decal affixed to it, make sure the new component also has the safety decal affixed.

USE CAUTION WHEN WORKING WITH HEAVY LOGS



WARNING! Always make sure log is clamped securely before sawing. Failure to do so may result in serious injury or death.

WARNING! Always leave hydraulic loading arm halfway up while log is on sawmill bed. Failure to do so may result in serious injury or death.

AUTOMATIC BOARD RETURN SAFETY



DANGER! Keep all persons out of the path of returning boards. Failure to do so will result in serious injury.



WARNING! The automatic board return is intended to assist a second operator in removing boards quickly. Do not use the board return when operating the sawmill alone. Serious injury, death or damage to the equipment may result.

WARNING! Never use the board return table as a platform to stand on. This table is designed and intended to assist in the removal of boards only. Standing on the table may result in serious injury.

UP/DOWN SYSTEM SAFETY



WARNING! Always secure the saw head with a 5/16" chain with at least 1900 lbs. working load capacity before adjusting the up/down chain. The saw head may fall, causing severe injury or death.

WARNING! Always secure the saw head with a 5/16" chain with at least 1900 lbs. working load capacity before adjusting the mast pads. The saw head may fall, causing severe injury or death.

WARNING! Always secure the saw head with a 5/16" chain with approximately 1900 lbs. working load capacity before removing the up/down motor belt. The saw head may fall, causing severe injury or death.

POWER FEED SYSTEM SAFETY



DANGER! If leaving the blade engaged for maximum production rates, make sure the off-bearer stays out of the path of the blade. Failure to do so will result in serious injury or death.



WARNING! Be sure the power feed switch is in the neutral position before turning the key switch to the on (#1) or accessory (#3) position. This prevents accidental carriage movement which may cause serious injury or death.

GENERAL TRAILER SAFETY



DANGER! Make sure your hitch has adequate safety chain hook-ups. Do not use eyebolts for safety chain hook-up. Safety chains should be hooked to bumper of vehicle so that each chain would pull the trailer equally in the event the hitch became disengaged. Failure to do so may result in serious personal injury and/or severe machine damage.

DANGER! Be sure that the hitch and safety chains are secure before towing the sawmill. Failure to do so may result in serious personal injury and/or severe machine damage.

DANGER! Make sure all light connections have been made and are working properly before towing the sawmill. Failure to do so may result in serious personal injury and/or severe machine damage.



WARNING! The trailer option is designed for the express purpose of towing the sawmill it is supplied with. Do not make modifications or additions that affect the weight and/or stability of the towing unit. Doing so may result in property damage and/or serious injury or death.

WARNING! Always check trailer tires for proper inflation before towing sawmill. Failure to do so may lead to tire failure resulting in property damage and/or serious injury or death.

ADDITIONAL SAFETY FOR ELECTRIC BRAKE TRAILERS



DANGER! Make sure the electric brake wire is secured as close to the trailer axle as possible to prevent wire disconnection during towing. Failure to do so may result in serious personal injury and/or severe machine damage.

DANGER! Be sure electric brake battery is charged and is working properly before towing the sawmill. Failure to do so may result in serious personal injury and/or severe machine damage.

DANGER! Do not use the electric brake system as an “emergency brake” while the sawmill is not being towed. Extended use of the electric brakes while the sawmill is stationary will drain the brake battery.

SECTION 3 SAWMILL SETUP

3.1 Stationary Sawmill Setup

Prepare a firm, level area where the sawmill can be anchored. There should be enough room around the sawmill for operators, sawdust removal, log loading and board removal. A cement pad with 5/8" diameter anchor bolts is recommended. The cement pad should be rated to support 6350 lbs./sq.ft. at each sawmill foot position.

[See Form #847](#) for stationary sawmill foot anchor locations. [See Form #359](#) for stationary sawmill with bed extension foot anchor locations. [See Form #542](#) for complete electric sawmill installation instructions.

NOTE: Make sure the unit is level before securing. It IS possible to twist the mill frame by jacking one foot higher than the others.

 **WARNING!** Securely fasten the feet of a stationary sawmill to the floor before operating the sawmill. Failure to do so may result in serious injury or death.

1. Unhook the carriage safety chain, located at the bottom of the vertical mast, near the battery box.
2. Start the engine to enable the battery-operated accessories ([See Section 3.6](#)). Use the up/down switch on the control panel to raise the cutting head from the carriage rest pin. Remove the locking pin and swing the rest pin down below bed level.



 **CAUTION!** Always make sure the engine is running before operating the sawmill controls. Operating the controls without the engine running will result in power drainage from the battery.

3. Use the carriage forward/reverse switch (left side of control box) to move the cutting head toward the front end of the mill.



4. Raise the side supports to prevent a log from falling off the side of the mill when loaded.

See Figure 3-1.

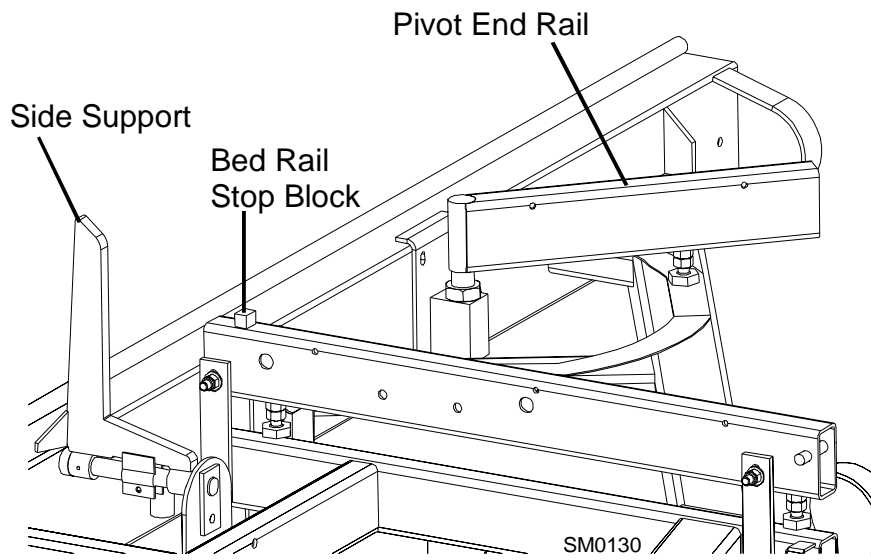

FIG. 3-1

3.2 Portable Sawmill Setup



WARNING! Do not set up the mill on ground with more than a 10 degree incline. If setup on an incline is necessary, put blocks under one side of the mill or dig out areas for outrigger legs to keep mill level. Setting up the mill on an incline could cause it to tip over, resulting in serious personal injury.

WARNING! Chock the trailer wheels to prevent movement before unhitching it from the towing vehicle. Failure to do so may result in serious injury or death.

WARNING! Always make sure the trailer is supporting the sawmill frame when operating a sawmill with adjustable outriggers. Failure to do so may result in serious injury or death. The adjustable outriggers are intended to support the saw frame with assistance from the trailer.

WARNING! The adjustable outriggers supplied with portable sawmills are not intended for setup on concrete or other hard surfaces. Long-term use of the adjustable outriggers on hard surfaces may cause the outriggers to fail, causing the sawmill to drop. This could result in possible serious injury or death.

If setting the sawmill up on concrete or other hard surface, replace the adjustable outrigger legs with stationary legs.

1. Unhitch the mill from the vehicle.
2. Lower and set the front three outriggers. To lower, use the provided jack handle to lift the weight from the locking pin. If necessary, rotate the locking pin counterclockwise so that the inner roll pin is free from the outrigger channel notch, then pull the locking pin out to release the outrigger. Lower the outrigger as necessary. Push the locking pin back in and turn clockwise until the inner roll pin is behind the outrigger channel notch to “lock” the outrigger in place.

 **WARNING!** Put front outrigger down before moving cutting head from the rest position. Failure to do so may result in serious injury.

See Figure 3-2.

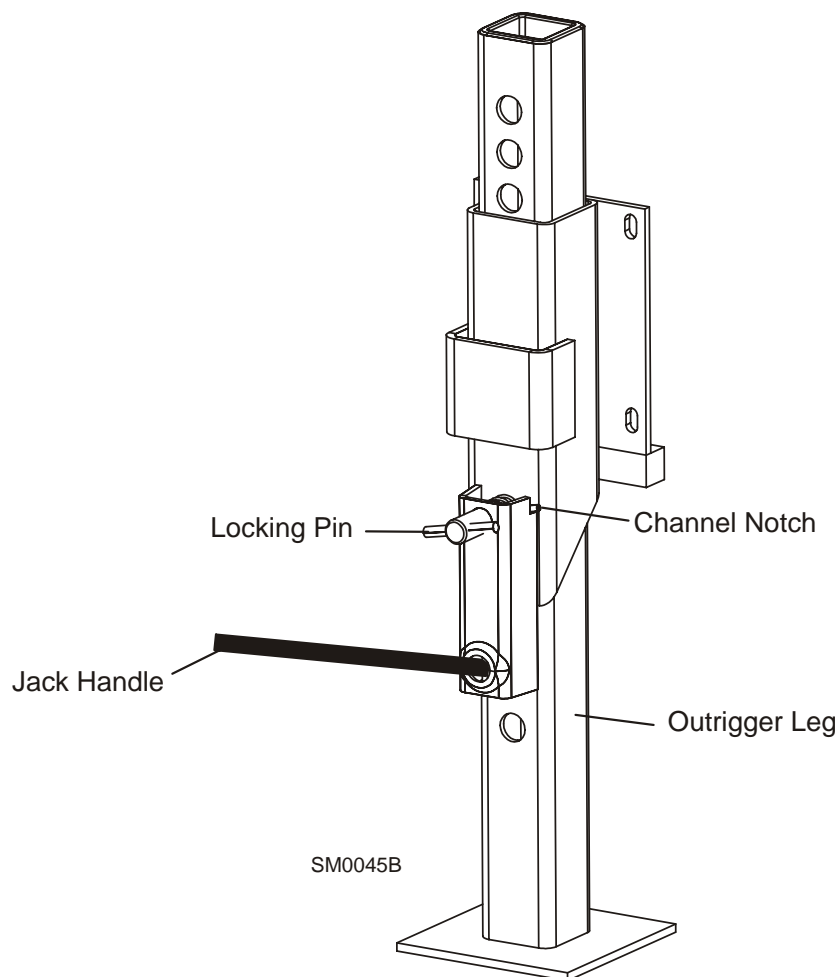

FIG. 3-2. OUTRIGGER ADJUSTMENT.

See **Figure 3-3**. For Fine Adjust Outriggers (FAOs), lower the outrigger as close to the ground as possible, then secure in place with the locking pin. Adjust the outrigger base so that it contacts the ground. To adjust, use the provided wrench to turn the height adjustment nut. Turn clockwise to lower. Turn counterclockwise to raise. Maximum adjustment available is 1 1/2" (3.8 cm).



CAUTION! Do not adjust the FAO outrigger base height while there is weight on the FAO. Damage to the FAO may result.

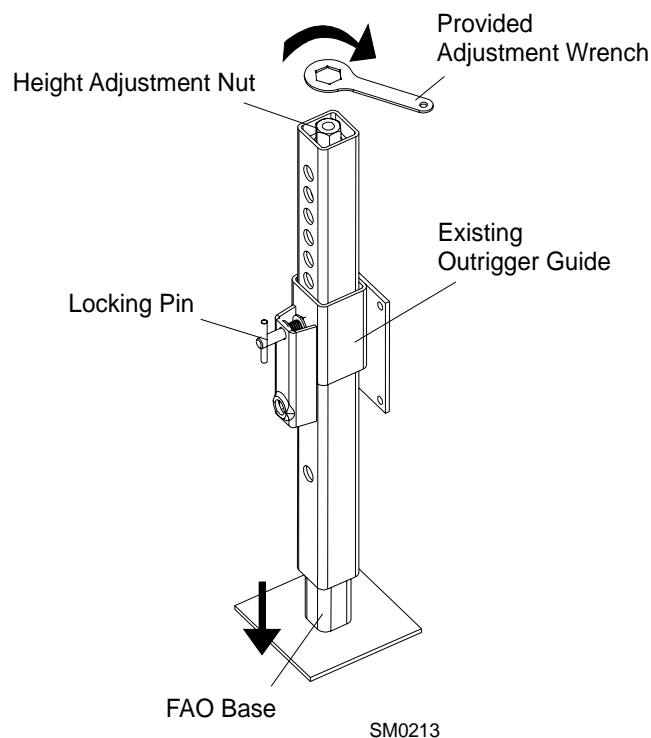

FIG. 3-3. BASE HEIGHT ADJUSTMENT (FOR FINE ADJUST OUTRIGGER ONLY).

1. Unhook the carriage safety chain, located at the bottom of the vertical mast, near the battery box.
2. Start the engine to enable the battery-operated accessories ([See Section 3.5](#)). Use the up/down handle on the control box to raise the cutting head from the carriage rest pin. Remove the locking pin and swing the rest pin down below bed level.



CAUTION! Always make sure the engine is running before operating the sawmill controls. Operating the controls without the engine running will result in power drainage from the battery.

3. Remove the fenders by lifting them out of the slots.



CAUTION! To prevent fender damage, remove fenders before operating sawmill or loading logs.



4. Use the feed control handle (left side of control box) to move the cutting head toward the front end of the mill.
5. Lower and set the remaining rear outriggers. Level the sawmill by adjusting the outriggers to raise or lower each end of the sawmill. Adjust all outriggers evenly to avoid twisting the mill frame by jacking one outrigger higher than the others.

For FAO(s), fine tune the outrigger base height as necessary. Move the cutting head to the opposite end of the mill from the outrigger. Raise the entire outrigger (to remove the sawmill weight from it) and adjust the outrigger base as necessary. Lower the entire outrigger and use the locking pin to secure in position.



CAUTION! Do not adjust the FAO outrigger base height while there is weight on the FAO. Damage to the FAO may result.

6. Raise the two side supports to prevent the log from falling off the side of the mill when loaded.

See Figure 3-4.

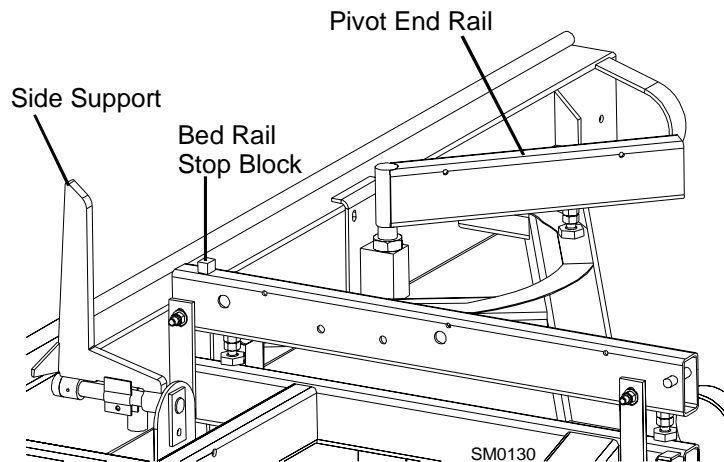

FIG. 3-4

3.3 Replacing The Blade



DANGER! Always disengage the blade and shut off the sawmill engine before changing the blade. Failure to do so will result in serious injury.



WARNING! Always wear gloves and eye protection when handling bandsaw blades. Changing blades is safest when done by one person! Keep all other persons away from area when coiling, carrying or changing a blade. Failure to do so may result in serious injury.

Adjust the blade guide arm all the way open.

Remove the two blade housing covers that cover the blade wheels. Lower the hinged middle blade housing cover. Turn the blade tension handle to release the blade tension until the wheel is pulled in and the blade is lying loose in the blade housing. Lift the blade out of the blade housing.

When installing a blade, make sure the teeth are pointing the correct direction. The teeth should be pointing toward the operator side of the mill when you are looking at the blade below the blade guides. Install the blade so it is lying around the wheels.



CAUTION! Be careful when placing the blade between the guide rollers and inserts. If the blade hits one of the inserts hard enough, it could damage the insert.

Position 1 1/4" wide blades on the wheels so the gullet is 1/8" (3.0 mm) out from the edge of the wheel. Position 1 1/2" wide blades on the wheels so the gullet is 3/16" (4.5 mm) out from the edge of the wheel.

Close the middle blade housing cover.

Next, turn the tension handle until the blade is tensioned correctly.

3.4 Tensioning The Blade

See **Figure 3-5**. Tension the blade by turning the hydraulic tensioning handle clockwise until the tension gauge indicates the recommended tension.

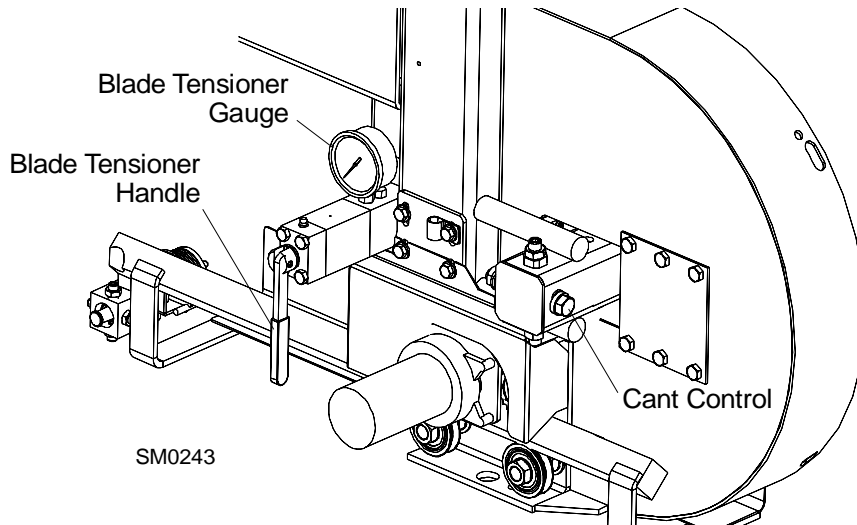

FIG. 3-5

See **Table 3-1**. The recommended tension for different blades is shown below.

Blade Type	Acceptable Range	Ideal Tension
.035" x 7/8" x 1 1/4"	1800 - 2100 psi	2000 psi
.042" x 7/8" x 1 1/4"	2100 - 2400 psi	2300 psi
.045" x 7/8" x 1 1/2"		
.050" x 7/8" x 1 1/2"		
.055" x 7/8" x 1 1/2"		

TABLE 3-1

The tension gauge should be checked occasionally when adjusting the cant control or while cutting. Ambient temperature changes will cause tension to change. Adjust the tension handle as necessary to maintain the recommended tension level.



CAUTION! Changes in temperature could cause increased pressure in the blade tensioner and loss of fluid from the gauge. Release the blade tension when the mill is not in use to avoid damage to the tensioner.

3.5 Tracking The Blade

1. Make sure the middle blade housing cover is closed and all persons are clear of the open side of the saw head.
2. Start the engine (or motor).
3. Engage the blade, rotating the blade until the blade positions itself on the wheels.



WARNING! Do not spin the blade wheels by hand. Spinning the blade wheels by hand may result in serious injury.

4. Disengage the blade. Turn off the engine, remove the key and check the position of the blade on the blade wheels.

See Figure 3-6. Position 1 1/4" wide blades so the gullet is 1/8" (3.0 mm) out from the edge of the blade wheel ($\pm 1/16$ [1.5 mm]). Position 1 1/2" blades so the gullet is 3/16" (4.5 mm) out from the edge of the blade wheel ($\pm 1/16$ [1.5 mm]).

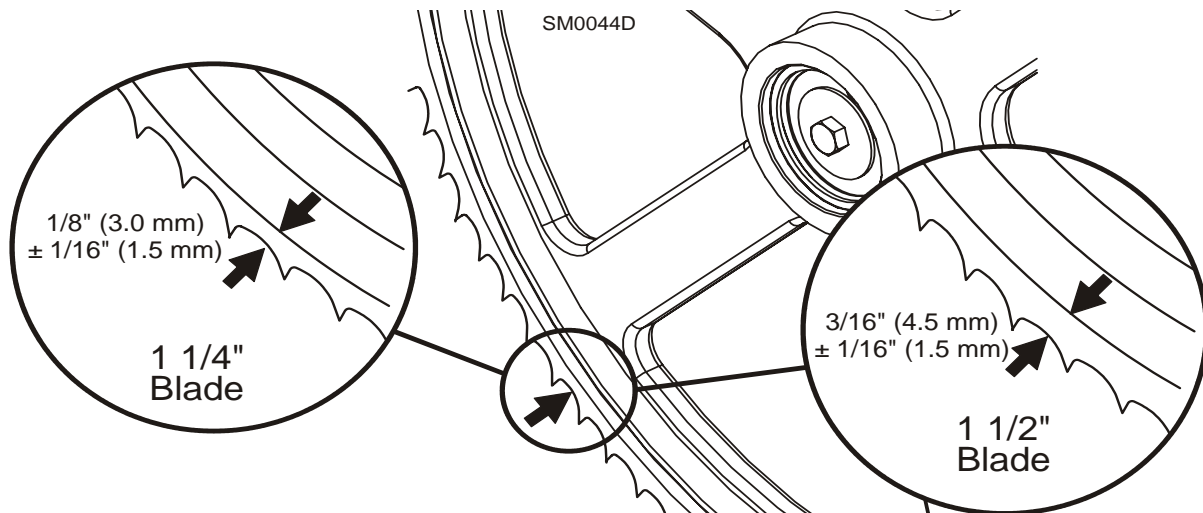

FIG. 3-6

5. To adjust where the blade travels on the blade wheels, use the cant control shown in **Figure 3-5**.

If the blade is too far out, back the blade onto the wheel by turning the cant control counterclockwise. If the blade is too far in, turn the cant control clockwise until the gullet of the blade is the correct distance from the front edge of the wheel.

6. Adjust the blade tension if necessary to compensate for any changes that may have

occured while adjusting the cant control.

7. Close the middle blade housing cover and replace the large blade housing covers.



DANGER! Make sure all guards and covers are in place and secured before operating or towing the sawmill. Failure to do so may result in serious injury. Be sure the blade housing and pulley covers are in place and secure. Use the safety retainer pin and cable to fasten blade housing covers.



IMPORTANT! After aligning the blade on the wheels, always double-check the blade guide spacing and location. ([See Section 7](#) for more information.)

3.6 Starting The Engine (or Motor)

See the appropriate manual supplied with your specific engine/motor configuration for starting and operating instructions.



DANGER! Make sure all guards and covers are in place and secured before operating or towing the sawmill. Failure to do so may result in serious injury. Be sure the blade housing and pulley covers are in place and secure. Use the safety retainer pin and cable to fasten blade housing covers.

DANGER! Always be sure the blade is disengaged and all persons are out of the path of the blade before starting the engine or motor. Failure to do so will result in serious injury.



WARNING! Always wear eye, ear, respiration, and foot protection when operating the sawmill. Failure to do so may result in serious injury.

WARNING! Be sure the power feed switch is in the neutral position before turning the key switch to the on (#1) or accessory (#3) position. This prevents accidental carriage movement which may cause serious injury or death.

3.7 Board Return



WARNING! The automatic board return is intended to assist a second operator in removing boards quickly. Do not use the board return when operating the sawmill alone. Serious injury, death or damage to the equipment may result.

WARNING! Never use the board return table as a platform to stand on. This table is designed and intended to assist in the removal of boards only. Standing on the table may result in serious injury.

The sawmill is equipped with a board return system. This system consists of an arm on the saw head controlled by a toggle switch on the control panel. A board return table is also provided to catch the board as it is removed from the log. Use of the board return not recommended with material shorter than 8 foot.

All LT30HD Super Revs & LT40HD Super before Rev. J9.01 Only: Move the board return table from the transport storage position at the rear of the mill to the operational position at the front of the mill. Remove the two pins securing it in its storage position at the rear of the sawmill.

See Figure 3-7.

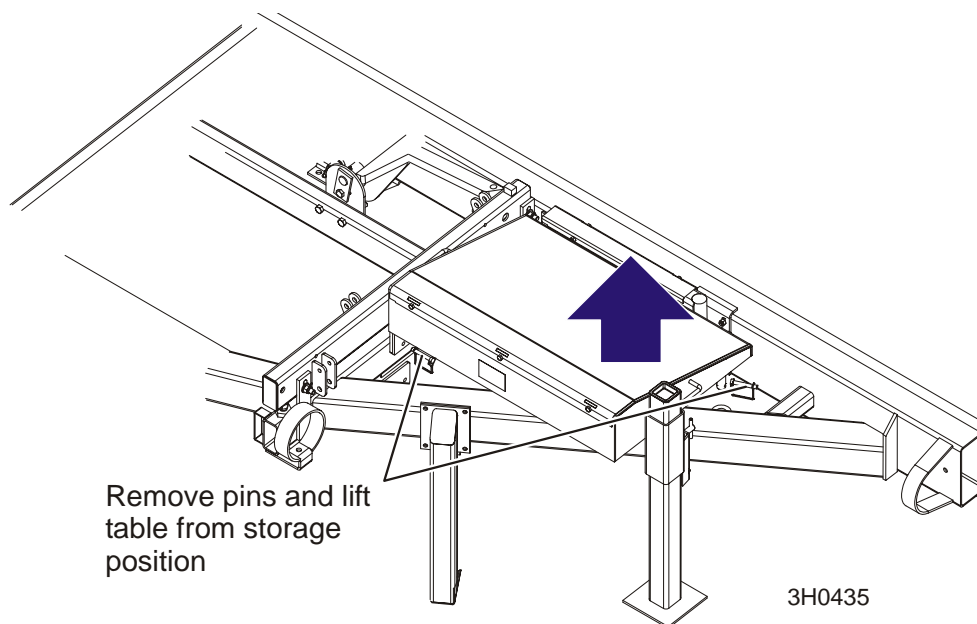

FIG. 3-7

3

Sawmill Setup

Board Return

Install the table at the front of the sawmill bed with the outrigger toward the loading side of the sawmill.

See Figure 3-8. Be sure the edge of the table seats in the slot on the bed frame and the table tab seats in the leg bracket. Lower the outrigger and adjust it until it is firmly planted on the ground.

Store the pins by placing one pin in the hole under the table. Loop the second pin through the retainer of the first pin and lock.

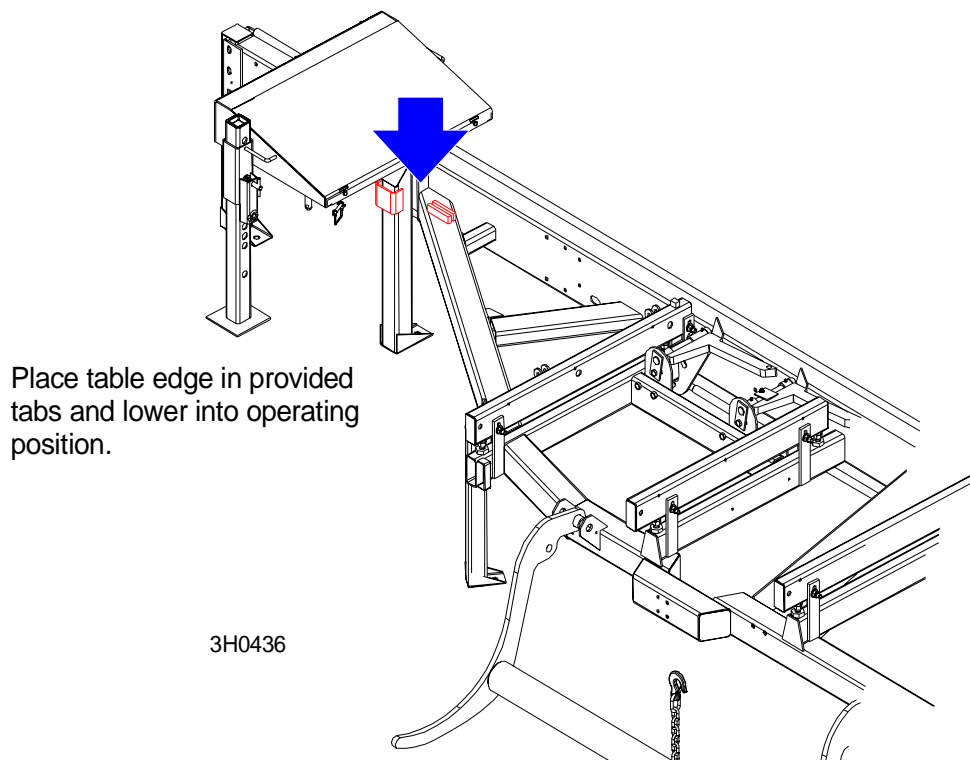

FIG. 3-8

When done sawing, return the board return table to its storage position and secure with both locking pins. Adjust the outrigger leg up to provide proper ground clearance when towing the sawmill.



CAUTION! To avoid damage to the board return table, secure it in its storage location before towing the sawmill.



To activate the board return, turn the key switch to the accessory (#3) or start (#1) position. Push the toggle switch on the control panel down. The board return arm located in the middle of the saw head will drop into position.

See Figure 3-9.

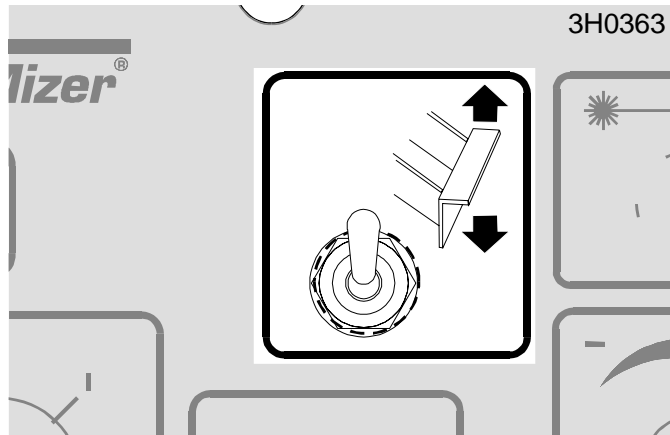

FIG. 3-9

When the blade reaches the end of the log, the arm will drop down to catch the board and drag it back toward the operator as the saw head is returned.



DANGER! Keep all persons out of the path of returning boards. Failure to do so will result in serious injury.

Boards may not always return in the same path or location. If a board returns in a manner that does not allow the sawyer or off-bearer to maintain control, it may be necessary to stop the reverse motion of the saw head.

When the board return is to be used, a second person is required to remove the board as it is returned. **DO NOT** attempt to use the board return feature when sawing alone.

To bypass the board return feature, push the toggle switch on the control panel up.

SECTION 4 SAWMILL OPERATION

4.1 Hydraulic Control Operation

The hydraulic control levers become operational when the contacts at the bottom of the carriage touch the power strip on the frame tube. The hydraulic control levers will only work when the cutting head is close enough to the front end of the mill to touch the power strip.

See Figure 4-1. Hydraulic units have six control levers to load, clamp, turn and level logs.

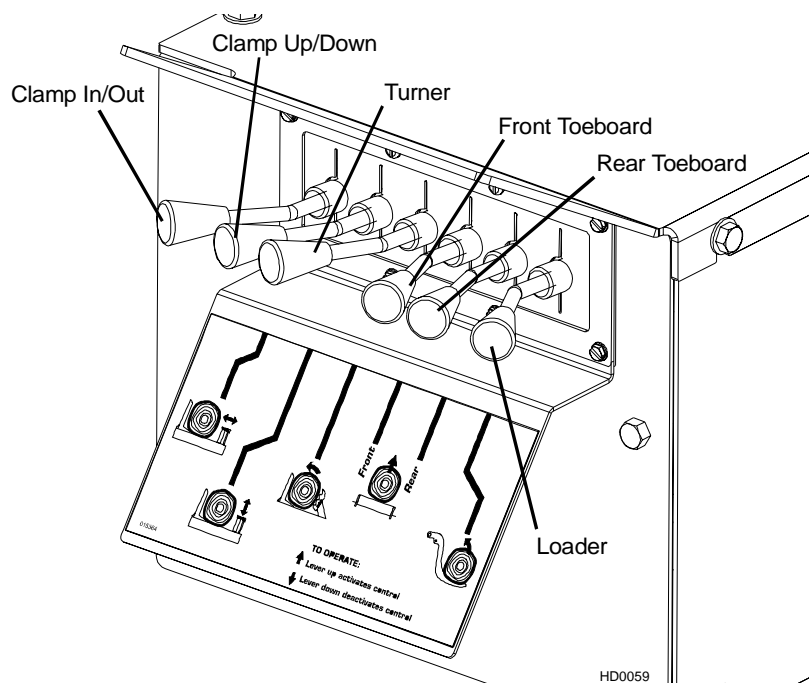

FIG. 4-1

Use the hydraulic control levers to get the mill ready to load a log.

! DANGER! Keep all persons out of the path of moving equipment and logs when operating sawmill or loading and turning logs. Failure to do so will result in serious injury.

! CAUTION! Always make sure the engine is running before operating the hydraulic controls. Operating the controls without the engine running will result in power drainage from the battery. Holding the hydraulic switches halfway up or down also will cause excessive drainage from the battery.

1. Move the clamp out and down so it will not get in the way of logs being loaded onto the bed.



Lower the clamp in/out lever to move the clamp out toward the loading side of the sawmill.



Lower the clamp up/down lever to lower the clamp below bed level.

2. Raise the log loader lever to extend the legs of the log loader out as far as they will go.



3. The chain securing the log loading arm to the log turner arm will be tight. Raise the log turner lever to raise the turner arm until there is slack in the chain.



4. Unchain the loading arm from the turner arm.

5. Lower the turner lever to completely lower the turner arm. Notice that after the turner arm is all the way down, the side support braces will begin to lower. Release the turner lever after the turner arm is lowered, but before the side supports begin to lower. This stops the log being loaded from damaging the turner and/or falling off the side of the sawmill.



6. When raising the turner lever, the side supports rise first. After reaching a fully vertical position, the turner arm will engage and start to rise.

7. Manually lower the log loader so it rests on the ground.



CAUTION! Be careful when manually lowering the log loader. Do not drop the loader onto the ground or perform any action which might break the velocity fuse valves on the loader cylinders. These valves control hydraulic flow and are necessary to prevent the loading arm from collapsing during use.

8. Lower the loader lever to lower the loading arm as far as it will go. Logs must be rolled onto the loading arm one at a time for loading onto the bed of the mill.



9. The front and rear toe boards should be below bed level. Once a tapered log has been loaded, the front or rear end of the log may be lifted to parallel the heart of the log to the path of the blade.



The front toe board is raised by lifting the front toe board lever up. The rear toe board is raised by lifting the rear toe board lever up. Once a flat has been made and the log is ready to be turned, push the appropriate toe board lever down to lower either toe board until it falls below the level of the bed.

4.2 Loading, Turning And Clamping Logs

To Load Logs

1. Move the saw carriage to the front end of the frame.



CAUTION! Before loading a log, be sure the cutting head is moved far enough forward so the log does not hit it. Failure to do so may result in machine damage.



CAUTION! Be sure the log clamp, pivot rails, turning arm and toe boards are adjusted out of the path of the log before loading a log onto the bed. Failure to do so may result in machine damage or cause misalignment.

2. Raise the side supports on the sawmill bed to prevent the log from falling off the side of the bed.
3. Use cant hooks or loading equipment to move the log to the foot of the loading arms.
4. Roll the log onto the loader so that it is approximately centered with the sawmill bed. The log turner will operate much easier if the log is centered on the sawmill bed.



DANGER! Keep all persons out of the path of moving equipment and logs when operating sawmill or loading and turning logs. Failure to do so will result in serious injury.

5. Start the engine and raise the loader lever to raise the log onto the sawmill bed. Simply let the loader rise until the log rolls onto the mill bed.



6. Lower the loading arm. Leave the loading arm about halfway up while squaring the log. This will stop the log from rolling off the side of the mill.



WARNING! Always leave loading arm halfway up while log is on sawmill bed. Failure to do so may result in serious injury or death.

NOTE: Logs also may be loaded onto the mill with a tractor or other equipment specifically designed for that purpose.

7. Raise the clamp up/down lever to raise the clamp up to prevent the log from rolling off the bed.



To Turn Logs

1. Raise the turner lever to engage the log turner arm. Let the arm rise until it touches the log and starts to turn it.



2. Spin the log against the side supports until it is turned the way you want it for the first cut.

3. To turn the log more, clamp the log against the side supports and lower the turner arm below the log.



4. Raise the turner arm to get a new bite on the log.
5. Disengage the clamp and continue turning the log.
6. Repeat steps 3 through 5 until the log is turned as desired.

To Turn Logs (Optional Procedure)

If you are turning a small cant on a mill with two-plane clamp, you may opt to use the clamp to turn the cant.

1. Lower the clamp up/down lever to lower the clamp below bed level.
2. Raise the clamp in/out lever to move the clamp in, beneath the edge of the cant.
3. Raise the clamp up/down lever to raise the clamp and flip the cant.

To Clamp Logs

1. Raise the clamp in/out lever and clamp the log against the side supports.



2. Lower the turner lever until the turner arm falls below the bed.



3. When the turner arm is lowered all the way, the side supports will begin to lower. Back the clamp off slightly, and let the side supports come down until they are positioned below the level of your first few cuts.

To Level A Tapered Log

Use the toe board lever(s) to raise either end of a tapered log, if desired.



Raise the appropriate lever to raise the front or rear toe board until the heart of the log measures the same distance from the bed rails at each end of the log.

4 Sawmill Operation

Up/Down Operation

4.3 Up/Down Operation

This section describes operation of the up/down system with the standard controls. See the operation section of the Setworks, Accuset or Simple Set manual for alternate instructions for operating the up/down system.

1. Install a blade, if needed, and check for correct blade tension. ([See Section 3.3](#)).
2. Set the cutting head to the desired height. (The blade height scale shows the height of the blade above the bed rails.)



See Figure 4-2. The up/down switch is located on the far right side of the control panel. Push the switch up to raise the cutting head; push the switch down to lower the cutting head. Hold the switch in position until the cutting head reaches the desired height, then release.

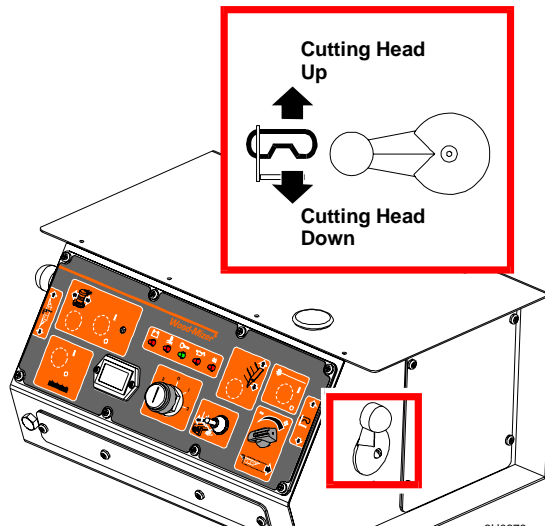

FIG. 4-2

The up/down switch is designed to return to the neutral or "off" position when released. If the switch remains engaged, manually move the switch to the neutral or "off" position. Repair the up/down drum switch ([See Section 6.2](#)).



CAUTION! Always make sure the up/down switch moves to the neutral or "off" position when released to ensure that the saw head stops moving. Failure to do so may result in machine damage.

CAUTION! DO NOT try to force the carriage above the 35" (88 cm) mark or below the 1" (2.54 cm) mark. Damage to the up/down system may result.

4.4 Blade Guide Arm Operation

1. Look down the length of the log to see its maximum width. The outer blade guide should be adjusted to clear the widest section of the log by less than 1" (25.4 mm).



2. Use the blade guide toggle switch on the control panel to adjust the outer blade guide as necessary. Push the switch to the left to move the arm in. Push the switch to the right to move the arm out.



See Figure 4-3.

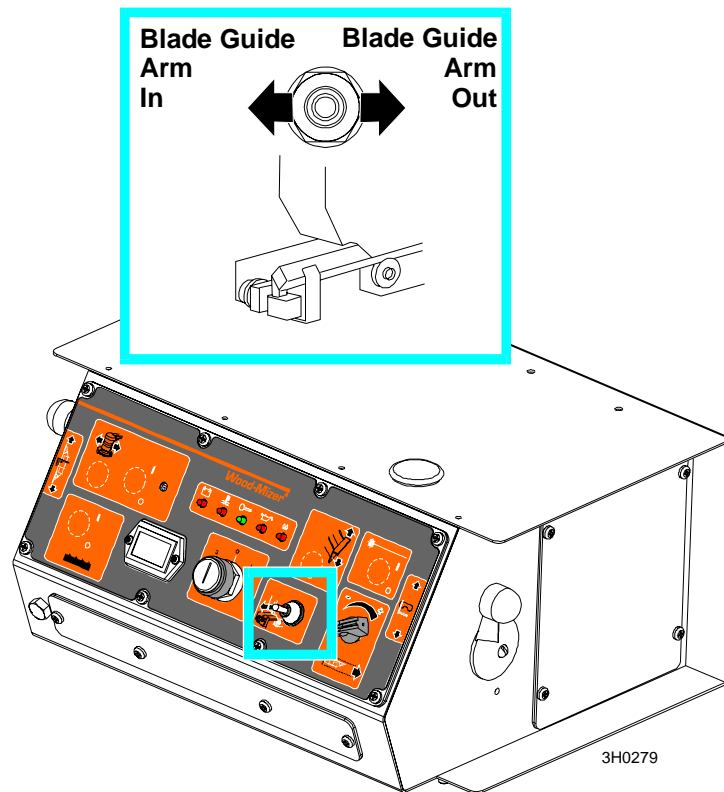

FIG. 4-3

3. Use the blade guide toggle switch to readjust the outer blade guide as you are cutting in order to keep the guide within 1" (2.5 cm) of the log. Be sure to adjust the arm back out before returning the carriage.

4.5 Clutch/Brake Operation

NOTE: If your sawmill is equipped with the Autoclutch Option, see the [Autoclutch Option manual](#) for clutch operating instructions.

1. Clear any loose objects from the area of the blade, motor, and drive belt.
2. Make sure the clamp and side supports are adjusted below the level of your first few cuts.
3. Start the engine or motor as instructed in the option manual.



DANGER! Keep all persons out of the path of moving equipment and logs when operating sawmill or loading and turning logs. Failure to do so will result in serious injury.

Be sure the blade housing and pulley covers are in place and secure before starting the engine or motor. Use the safety retainer pin and cable to fasten the blade housing covers shut.

See **Figure 4-4**. The clutch/brake lever is located next to the engine.

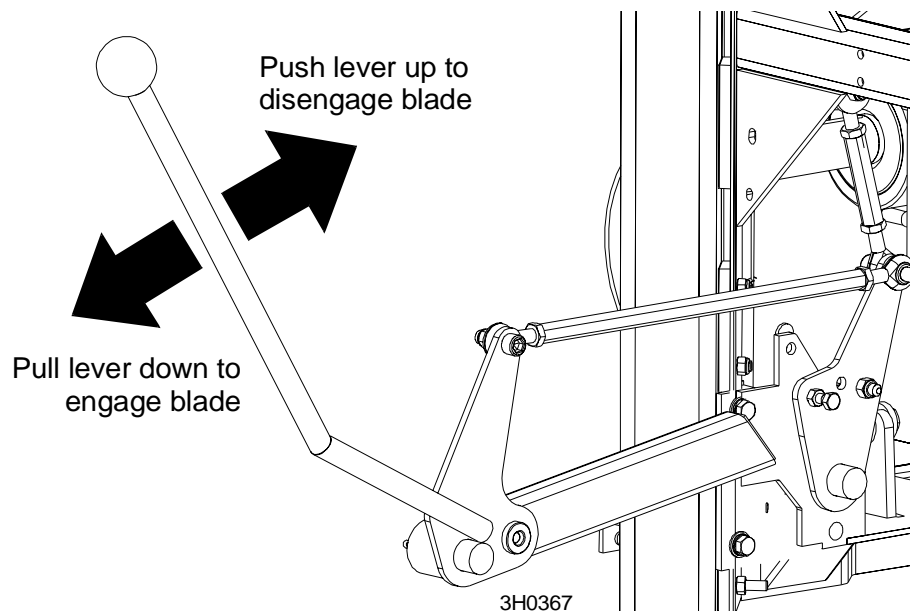

FIG. 4-4

4. To engage the blade, pull the clutch/brake lever down until it locks in the down position. This engages the drive mechanism, releases the blade brake, and increases the engine speed to full throttle.
5. To disengage the blade, raise the clutch/brake lever to the up position. This disengages the drive belt, engages the blade brake, and returns the engine to idle.

4.6 Power Feed Operation

See **Figure 4-5**. The power feed system moves the carriage forward and backward by using two switches on the control panel.

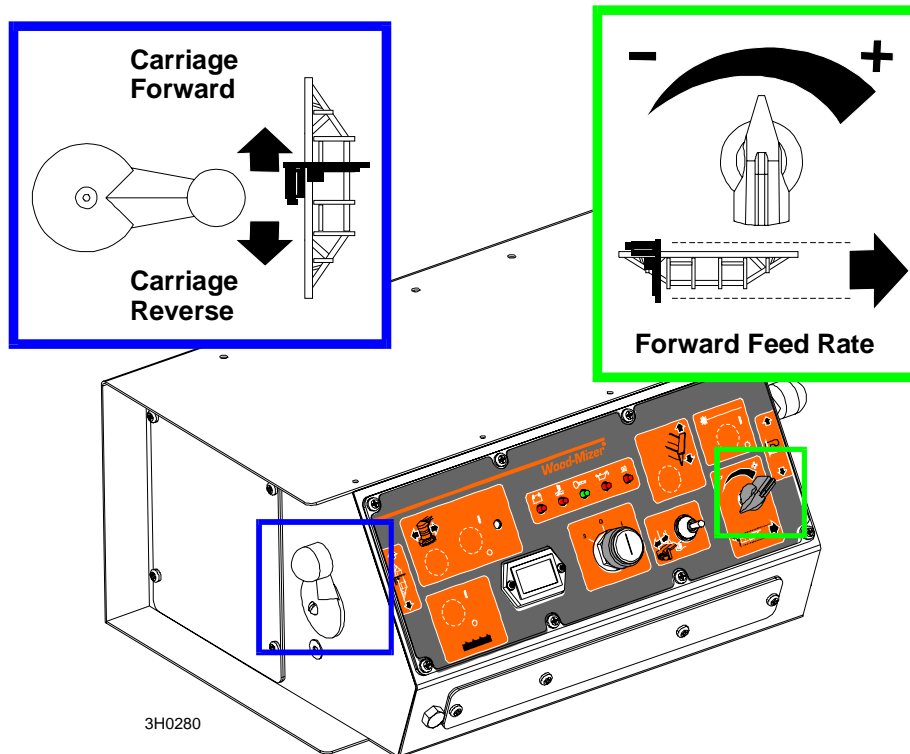

FIG. 4-5

Carriage Feed Rate



The carriage feed rate switch controls the speed at which the carriage travels forward. Turn the switch clockwise to increase speed. Turn it counterclockwise to reduce speed.

Carriage Forward and Reverse



The carriage forward/reverse switch controls the direction in which the carriage travels. Turn the forward/reverse switch upward to move the carriage forward. Turn the switch down to move the carriage backward.



The middle position (as shown) is the neutral position. The power feed switch is designed to return to the neutral or "off" position when released from operating in the reverse position. If the switch remains engaged, manually move the switch to the neutral or "off" position. Repair the drum switch ([See Section 5.6](#)).

 **WARNING!** Be sure the power feed switch is in the neutral position before turning the key switch to the on (#1) or accessory (#3) position. This prevents accidental carriage movement which may cause serious injury or death.

Using The Power Feed

1. To move the carriage forward, push the drum switch handle forward and turn the feed rate switch clockwise.



HINT: To get a straight cut in the first part of the board, feed the blade into the log at a slow speed. This stops the blade from flexing and dipping up or down. Turn the carriage feed rate switch to a slow speed until the whole width of the blade has entered the cut.



Then use the carriage feed rate switch to increase the feed rate as desired. Maximum feed rate varies with width and hardness of the wood. Over-feeding results in engine and blade wear, and also produces a wavy cut.

2. Stop the carriage at the end of the cut by turning the carriage feed rate switch counter-clockwise until the carriage stops moving. The blade will continue to spin as long as the blade motor is on. Use the optional sawing procedure described in Section 4.9. Throw the clutch/brake lever up or the optional autoclutch toggle switch down to stop the blade and drop the engine to idle. Remove the board from the top of the log. **Always disengage the blade before returning the carriage for the next cut.**



Use the optional sawing procedure described in Section 4.9. Throw the clutch/brake lever up or the optional autoclutch toggle switch down to stop the blade and drop the engine to idle. Remove the board from the top of the log. **Always disengage the blade before returning the carriage for the next cut.**

 **CAUTION!** Be sure to stop the blade when returning the carriage. This will not only prevent the blade from being pulled off and ruined by a wood sliver, but also will increase the life of the blade. [See Section 4.9](#) for optional sawing procedure for Super series mills.

3. Make sure that the blade does not catch on the end of the log. Raise the carriage slightly to make sure the blade clears the log when returned.



Return the carriage to the front of the mill by pushing the drum switch handle down. The power feed motor will bypass the carriage feed rate switch and the carriage will automatically return at the fastest speed available. [See Section 4.9](#) for optional sawing procedure for Super series mills. **HINT:** Try to stop the blade while the heel of the blade is still on the log. Then bring the carriage back without adjusting the blade up. This lets you keep the blade at the current height setting so you can make the next blade height adjustment more quickly.

 **DANGER!** Stay clear of the area between the trailer axle and saw carriage. Failure to do so will result in serious injury.

4 Sawmill Operation

Cutting The Log

4.7 Cutting The Log

The following steps guide you through normal operation of the Wood-Mizer sawmill.

1. Once the log is placed where you want it and clamped firmly, move the saw head to position the blade close to the end of the log.

2. Use the blade height scale to determine where to make your first cut ([See Section 4.10](#)). The blade height scale will help you to do this. Set the blade to the desired height with the up/down handle. Make sure that the blade will clear all side supports and the clamp. Adjust the outer blade guide to clear the widest section of the log by moving the blade guide toggle switch.



NOTE: An optional laser sight is available to help determine where the blade will travel through the log. See the laser sight manual for detailed operating instructions.

3. Engage the clutch/brake lever (or autoclutch blade switch) to start the blade spinning.
4. Start the water lube if necessary to prevent sap buildup on the blade. [See Section 4.11](#).
5. If you want to use the board return function, push the toggle switch on the control panel down. [See Section 3.7](#).



6. Feed the blade into the log slowly ([See Section 4.6](#)). Once the blade completely enters the log, increase the feed rate as desired. Always try to cut at the fastest speed you can while keeping an accurate cut. Cutting too slowly will waste blade life and lower production!



7. As you get to the end of the log, slow down the feed rate. When the teeth exit the end of the log, stop the carriage. Disengage the clutch/brake lever (or autoclutch blade switch). Remove the slab that you have just cut from the log.



8. Use the carriage forward/reverse handle to return the carriage to the front of the mill. Always disengage the blade before returning the carriage for the next cut.



9. Repeat until the first side of the log is cut as desired. Set aside the usable flitches (boards with bark on one or both sides). You can edge them on the mill later.

10. Lower the toe boards, if they were used. Use the hydraulic levers to release the clamp and engage the log turner. Turn the log 90 or 180 degrees. Make sure the flat on the log is placed flat against side supports if turned 90 degrees. Make sure it is placed on bed rails if turned 180 degrees. If the log was turned 90 degrees and you are using toe boards to compensate for taper in the log, raise the front or rear toe board again on the second side of the log until the heart is parallel with the bed.



11. Repeat the steps used to cut the first side of the log until the log is square. Cut boards from the remaining cant by adjusting the blade height for the thickness of boards that you want.

Example: Remember that the blade cuts a 1/16 - 1/8" (1.6-3.2 mm) wide kerf. If you want 1" (25.4 mm) thick boards, lower the carriage 1 1/16 - 1 1/8" (27-28.6 mm) for each board.

4.8 Edging

The following steps guide you through edging boards on the Wood-Mizer sawmill.

1. Raise the side supports to 1/2 the height of the flitches, or the boards that need to be edged.
2. Stack the flitches on edge against the side supports.
3. Clamp the flitches against the side supports halfway up the flitch height. (Wider flitches should be placed to the clamp side. When they are edged, flip them over to edge the second side without disturbing the other flitches or without having to pull them from the middle of the stack).
4. Adjust the blade height to edge a few of the widest boards.
5. Loosen the clamp and turn the edged boards over to edge the other side.
6. Repeat steps 2-4.
7. Loosen the clamp and remove the boards that have good clean edges on both sides. Clamp the remaining flitches and repeat steps 2-5.

4.9 Optional Cutting Procedure for Super Series Mills

In order to achieve maximum production rates with Super Series mills, it may be desirable to leave the blade engaged when returning the carriage. (Normal operation procedures recommend disengaging the blade before returning the carriage for maximum blade life and fuel economy.)



DANGER! If leaving the blade engaged for maximum production rates, make sure the off-bearer stays out of the path of the blade. Failure to do so will result in serious injury or death.



CAUTION! If you choose to leave the blade engaged; raise the blade to clear the log before returning the carriage. Failure to do so may cause damage to the blade and/or sawmill.

4.10 Blade Height Scale

See **Figure 4-6**. The blade height scale is attached to the carriage head frame. It includes:

- a blade height indicator
- an inch scale
- a quarter scale

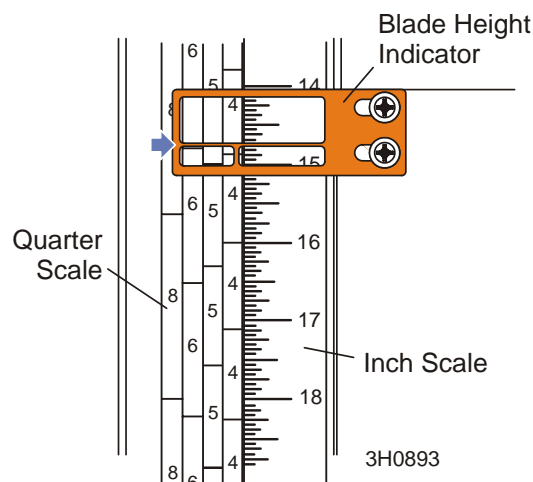

FIG. 4-6

The scales are attached to the frame and move up and down with the saw head. The blade indicator, used to read the inch and quarter scales, remains stationary.

The Inch Scale

The horizontal line on the blade height indicator shows how many inches the bottom of the blade is above the bed of the mill. If you know the height of your blade at each cut, you can determine the thickness of lumber you are sawing.

Example: You want to cut 1" (25 mm) random width boards from a log. Position the blade for the first cut. Move the carriage to an even measurement on the inch scale. Make a trim cut. Return the carriage for the second cut and lower it 1 1/8" (29 mm) below the original measurement. (The extra 1/8" (3 mm) allows for saw kerf and shrinkage of the lumber.)

The yellow area on the scale identifies where the blade could encounter a side support or log clamp. Check that these items are below the blade level before sawing.

The Quarter Scale

See Table 4-1. Two quarter scales are provided with four sets of marks. Each set represents a specific lumber thickness. Saw kerf and shrinkage allowance are included, but actual board thickness will vary slightly depending on blade thickness and tooth set.

To choose which scale to use, determine what finished thickness you want to end up with. The Grade Hardwood Quarter Scale provides thicker finished boards usually required by commercial buyers. The Standard Quarter Scale allows for kerf and shrinkage of finished boards suitable for most custom applications. Always check with your customer before you saw to determine what actual finished thickness is required.

Standard Quarter Scale		Grade Hardwood Quarter Scale	
Scale	Actual Board Thickness	Scale	Actual Board Thickness
4/4	1" (25 mm)	4/4	1 1/8" (29 mm)
5/4	1 1/4" (32 mm)	5/4	1 3/8" (35 mm)
6/4	1 1/2" (38 mm)	6/4	1 5/8" (41 mm)
8/4	2" (51 mm)	8/4	2 1/8" (54 mm)

TABLE 4-1

To use the quarter scale, look at the blade height indicator.

Loosen the wing studs holding the quarter scale to the mast. Align the nearest mark on the scale you want to use with the blade height indicator. Tighten the wing studs.



CAUTION! Be sure to leave the wing studs in the vertical orientation to avoid interference with the blade height indicator. Failure to do so may result in damage to the indicator.

Make a trim cut. When you return the carriage for a second cut, lower the carriage to the next mark on the scale. This mark shows where the blade should be positioned to cut a certain thickness of lumber, without having to measure on the inch scale.

Example: You want to cut 1" (25 mm) (4/4) random width boards from a log. Position the blade for the first cut. Adjust the quarter scale so a 4/4 mark is aligned with the line on the indicator. Make a trim cut. Return the carriage for the second cut. Now, instead of having to measure down 1 1/8" (29 mm) on the inch scale, you can simply lower the blade so the indicator is aligned with the next 4/4 mark on the quarter scale. Turn the log 90 degrees and repeat.

4.11 Water Lube Operation

The Water Lube System keeps the blade clean. Water flows from a 5-gallon (18.9 liter) bottle through a hose to the blade guide where the blade enters the log. A valve in the bottle cap controls the amount of water flow.

See Figure 4-7.

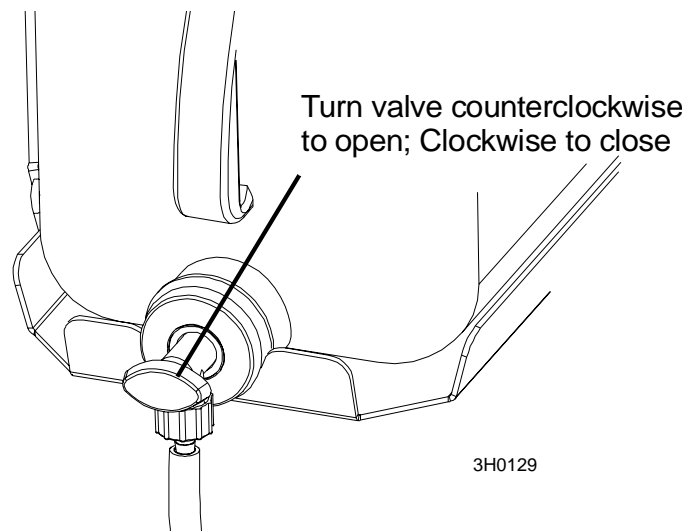

FIG. 4-7

Super models include a solenoid valve that will automatically start the water flow when the power feed is activated in the forward direction. The solenoid will stop the water flow when the feed switch is returned to the neutral position.

Not all types of wood require the use of the Water Lube System. When it is needed, use just enough water to keep the blade clean. This saves water, and lowers the risk of staining the boards with water. Usual flow will be 1-2 gallons (3.8-7.6 liters) per hour.

Before removing the blade, engage the blade. Let the blade spin with water running on it for about 15 seconds. This will clean the blade of sap buildup. Wipe the blade dry with a rag before storing or sharpening.

For further lubrication benefits, add one 12oz. bottle of Wood-Mizer Lube Additive to 5 gallons of water. Wood-Mizer Lube Additive enables some previously impossible timbers to be cut by significantly reducing resin buildup on the blade. It helps to reduce heat buildup, wavy cuts, and blade noise. This biodegradable and environmentally friendly pre-mix includes a water softener additive, so it works with hard water.



WARNING! Use ONLY water and Wood-Mizer Lube Additive with the water lube accessory. Never use flammable

fuels or liquids such as diesel fuel. If these types of liquids are necessary to clean the blade, remove it and clean with a rag. Failure to do so can damage the equipment and may result in serious injury or death.

If you are sawing in freezing temperatures, remove the water lube bottle from the sawmill when done sawing and store it in a warm place. Blow any remaining water from the water lube hose.

If your sawmill is equipped with the optional LubeMizer System, see the separate LubeMizer System manual for operation instructions.

4.12 Preparing The Sawmill For Towing

The Wood-Mizer trailer package makes transporting your sawmill easy and convenient. To get your sawmill ready for towing, follow these instructions.

All LT30HD Super Revs & LT40HD Super before Rev. J9.01 Only: Return the board return table to its storage position before towing the sawmill. [See Section 3.7.](#)



CAUTION! If the weight of the sawmill exceeds 3,000 lbs (1361 Kg) for any reason, an auxiliary braking system (such as electric brakes) must be used. Failure to do so may result in severe machine damage.

1. Move the saw carriage to the front end of the sawmill. Raise the rear outriggers.

See Figure 4-8. For Fine Adjust Outriggers (FAOs), make sure the outrigger base is adjusted so that the grease fitting is just below the lowest outrigger hole before securing the FAO in position with the lock pin. This provides maximum ground clearance while preventing the lock pin from hitting the grease fitting.

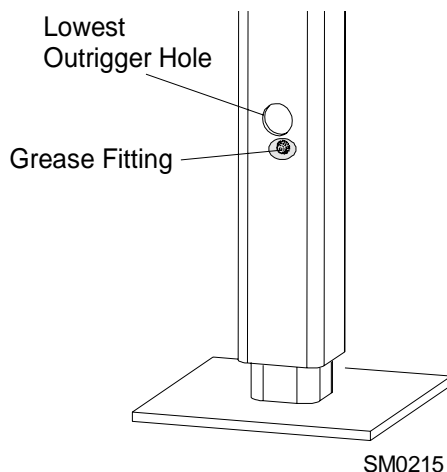

FIG. 4-8. FINE ADJUST OUTRIGGER ONLY.



CAUTION! Be sure the outrigger base is adjusted properly before securing the FAO in position with the lock pin. Failure to do so will cause damage to the outrigger grease fitting.



CAUTION! Do not adjust the FAO outrigger base height while there is weight on the FAO. Damage to the FAO may result.

2. Move the clamp all the way in toward the main bed frame pin tube.



CAUTION! Move the hydraulic clamp and turner to provide maximum ground clearance before towing. Failure to do so may result in damage to the sawmill.

3. Use the hydraulic controls to raise the log turner and loader as high as they will go. Manually lift the loader and hook the loader chain to the elbow of the turner. Use the hydraulic turner lever to lower the turner until the chain is tight. Push the loader lever down to bring the loader arm channels up to the loader.
4. Release the blade tension.



CAUTION! Changes in temperature could cause increased pressure in the blade tensioner and loss of fluid from the gauge. Release the blade tension when the mill is not in use to avoid damage to the tensioner.

5. Move the carriage forward to the travel position over the rear bed rail.
6. Position the hole in the saw head over the travel rest pin.
7. Lower the saw head until it is seated firmly on the rest pin.
8. Secure the rest pin in the vertical position with the locking pin.

See Figure 4-9.

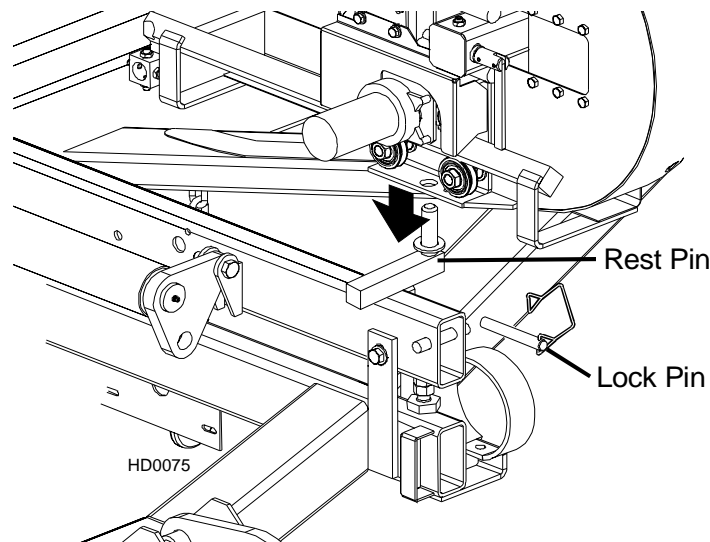

FIG. 4-9

4

Sawmill Operation

Preparing The Sawmill For Towing

9. Continue lowering the head 3/4" (19mm) until it contacts the stop blocks on the mast rails.



CAUTION! It is important that the lower stop bolts are properly adjusted to secure the carriage on the track rail. Failure to properly adjust the stop bolts can cause saw head damage, especially during mill transportation.

10. If necessary, adjust the two stops located at the bottom of the mast so the saw head contacts them after it is lowered 3/4" (19mm) past where it contacts the rest pin.

See Figure 4-10.

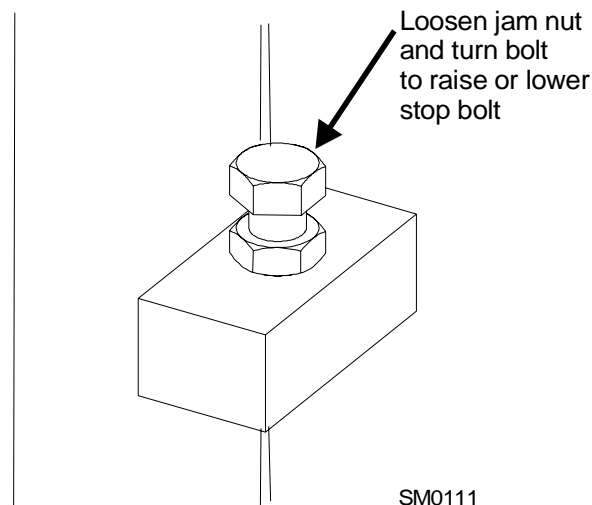

FIG. 4-10

11. Engage the clutch/brake lever or autoclutch blade switch. This keeps the drive belt tight and the motor from bouncing while traveling. Be sure to disengage the clutch/brake lever or autoclutch blade switch after reaching the destination to avoid deformation of the drive belt.
12. Hook the carriage safety chain located at the bottom of the carriage to the bracket at the bottom of the mast.

See Figure 4-11.

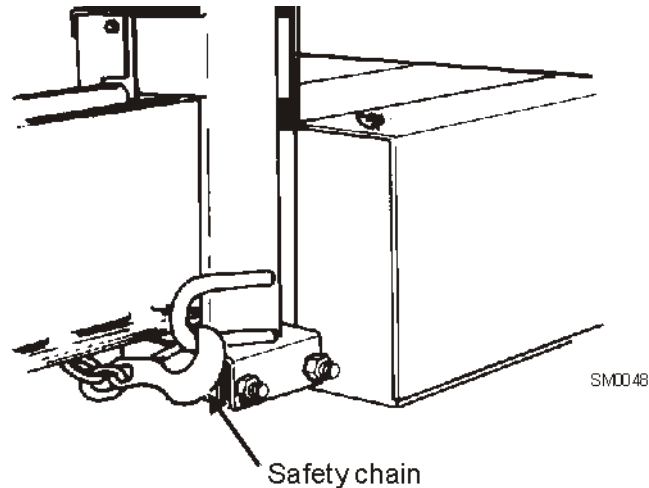

FIG. 4-11



CAUTION! Check to be sure the saw head safety chain is secured before towing the sawmill. Failure to properly secure the saw head can result in severe machine damage. Be sure the blade housing and pulley covers are in place and secure. Use the safety retainer pin and cable to fasten blade housing covers.

13. Remove all loose objects from the bed of the mill. Store the outrigger jack handle in the bracket provided on the rear/loading-side outrigger guide.
14. Place both fenders in the slots located behind the trailer tires and secure with rubber straps. Raise all but the very front outrigger.

For Fine Adjust Outriggers (FAOs), be sure to adjust the outrigger base height so that the grease fitting is just below the lowest outrigger hole before securing the FAO in position with the lock pin.



CAUTION! Be sure the outrigger base is adjusted properly before securing the FAO in position with the lock pin. Failure to do so will cause damage to the outrigger grease fitting.



CAUTION! Do not adjust the FAO outrigger base height while there is weight on the FAO. Damage to the FAO may result.

See the trailer operator's manual for specific information regarding hitch operation and towing the sawmill.

SECTION 5 MAINTENANCE

This section lists the maintenance procedures that need to be performed.

See the [Maintenance Log](#) located after this section for a complete list of maintenance procedures and intervals. Keep track of machine maintenance by filling in the machine hours and the date you perform each procedure.



This symbol identifies the interval (hours of operation) at which each maintenance procedure should be performed.

Be sure to refer to option and engine manuals for other maintenance procedures.

5.1 Wear Life

See Table 5-1. This chart lists estimated life expectancy of common replacement parts if proper maintenance and operation procedures are followed. Due to the many variables which exist during sawmill operation, actual part life may vary significantly. This information is provided so that you may plan ahead in ordering replacement parts.

Part Description	Estimated Life
Up/Down Motor Brushes (Non-Hydro)	1000 hours
B57 Blade Wheel Belts	400 hours
Up/Down Motor (Non-Hydro)	2000 hours
Hydraulic Pump Solenoid	750 hours
Power Feed Motor Brushes	750 hours
Up/Down Drum Switch (Non-Hydro)	1000 hours
Blade Guide Rollers	1000 hours
Hydraulic Pump Motor Brushes	750 hours
Power Feed Drum Switch (Non-Hydro)	1200 hours
Drive Belt	1250 hours
Power Feed Motor (Non-Hydro)	1500 hours
Power Feed Belt (Non-Hydro)	2000 hours
Up/Down Belt (Non-Hydro)	2000 hours

TABLE 5-1

5.2 Blade Guides



WARNING! Before performing service near moving parts such as blades, pulleys, motors, belts and chains, first turn the key switch to the OFF (#0) position and remove the key. If the key is turned on and moving parts activated, serious injury may result.

1. Check the rollers for performance and wear every blade change. Make sure the rollers are clean and spinning freely. If not, replace them. Replace any rollers which have worn smooth or have become cone shaped.

Blade Guides equipped with High-Performance Roller/Blocks Only:

2. Inspect the blocks at every blade change for damage or wear. If the block housing is bent or damaged, replace the block assembly. Also, replace the block assemblies before the blocks are worn to a point the blade may contact the lower step or housing.
3. Check the guide blocks are properly spaced from the blade every 25 hours of operation. Use the provided shim or a feeler gauge to check the blocks are adjusted .008" - .010" from the blade.

25

As the blocks wear, the front inside corner will wear more than the body of the block. When the corner wears far enough, sawing performance will be affected even if the body of the block is adjusted properly to the blade. At this point, the block should be replaced. If you have access to the appropriate equipment, you can grind or mill the blocks to a new flat surface and reuse them. It is recommended you develop a routine schedule for replacing the blade guide blocks based on your sawing conditions and experience.

See Figure 5-1. Rev. K1.01+:

To adjust the top block down, loosen the clamp bolt and mounting bolt. Turn the adjustment bolt clockwise. Retighten the mounting bolt and clamp bolt.

To adjust the bottom block up, loosen the clamp bolt and mounting bolt. Use the provided adjustment tool to turn the adjustment screw clockwise. Retighten the mounting bolt and clamp bolt.

 **IMPORTANT!** The blocks should be parallel to the blade. Check the space between the insert and the blade at each side of the insert to insure it is parallel. Use the appropriate outer adjustment bolt to tilt the insert mounting plate so the insert is parallel to the blade.

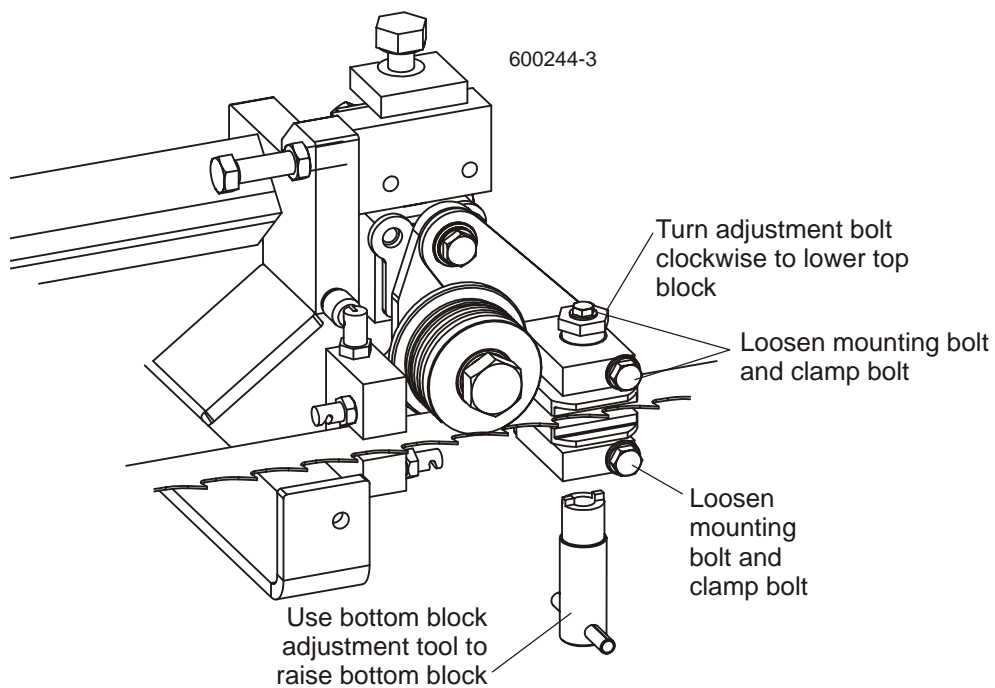

FIG. 5-1

See Figure 5-2. Prior to Rev. K1.01:

To adjust the blocks up, loosen the nuts on the outer adjustment bolts and back the bolts out slightly. Tighten the middle bolt to raise the block mounting plate up until it contacts the outer bolts. Check the space between the block and the blade. When proper spacing is achieved, tighten the outer bolt nuts.

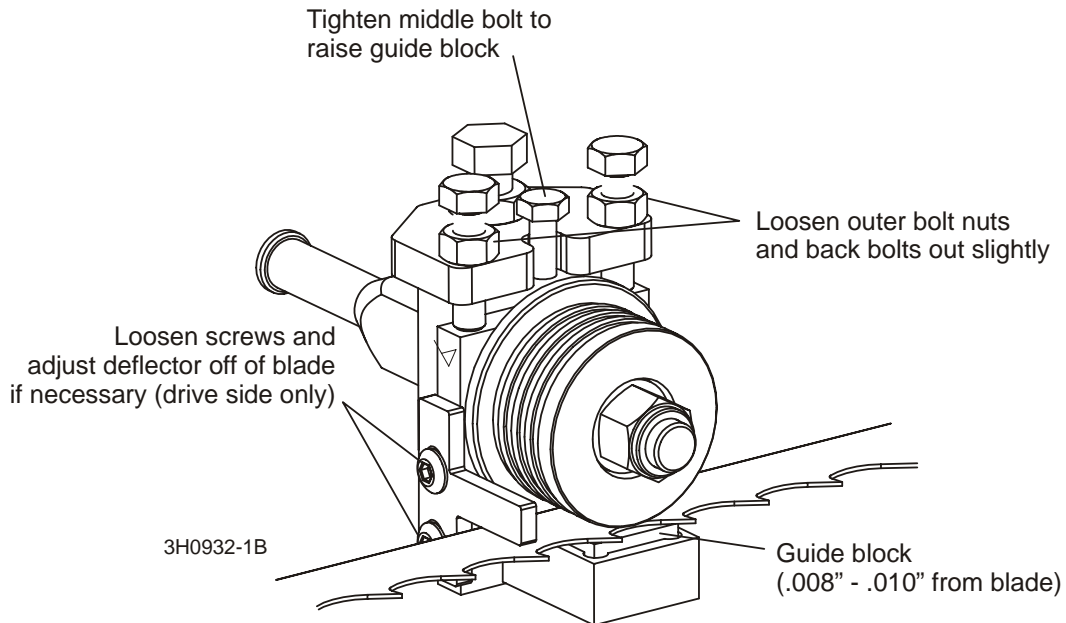

FIG. 5-2

Preventing sap buildup on the blade is critical when using the high-performance blade guide system. If the wood you are sawing leaves sap buildup using plain water in the blade lube system, use Wood-Mizer lube additive (4-Pak 60 oz. bottles part no. ADD-1).

5 Maintenance

Blade Guides

4. Make sure the blade screw in the top center of the C-frame is $1/16"$ (1.5 mm) away from the blade. If not, loosen the nut and adjust the screw as necessary. Check the screw every 500 hours of operation. Failing to maintain this adjustment will lead to early blade breakage.

See Figure 5-3.

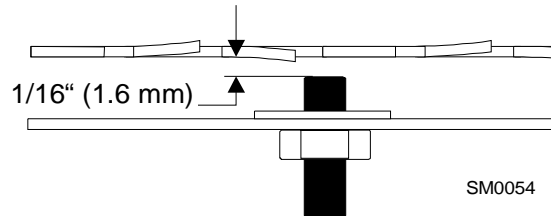

FIG. 5-3

5.3 Sawdust Removal



WARNING! Before performing service near moving parts such as blades, pulleys, motors, belts and chains, first turn the key switch to the OFF (#0) position and remove the key. If the key is turned on and moving parts activated, serious injury may result.



Remove the excess sawdust from the blade wheel housings and sawdust chute every blade change.



WARNING! Always keep clear of exiting sawdust. Keep hands, feet and any other objects away from the sawdust chute when operating sawmill. Failure to do so may result in serious injury.

WARNING! Always check to ensure the steel fingers inside the sawdust chute are in place before operating the sawmill. The steel fingers have been designed to help prevent a broken blade or some other object from becoming a projectile and exiting the sawdust chute. Failure to have these fingers in place may result in serious injury.



Remove all sawdust and debris from around the velocity fuse valves every 8 hours of operation. The valves are located at the bottom of the log loader cylinders.

Remove sawdust buildup as necessary from the battery box lid and top rail cover.



CAUTION! Failure to remove sawdust buildup from the battery box lid and/or track rail cover could result in damage to these parts when the saw head is lowered to its lowest position.



As required, remove sawdust buildup from the power feed belt housing. Turn the control panel key switch to OFF (0) and remove the key. Disassemble the power feed belt cover and remove sawdust buildup in and around the power feed belt and pulleys. Replace the power feed belt cover.

5.4 Carriage Track, Wiper & Scrapers



WARNING! Before performing service near moving parts such as blades, pulleys, motors, belts and chains, first turn the key switch to the OFF (#0) position and remove the key. If the key is turned on and moving parts activated, serious injury may result.

Properly maintaining the sawmill carriage track is critical in preventing corrosion that can cause pitting and scaling on the rail surfaces. Pitted and scaled surfaces can, in turn, cause rough cuts or jerky power feed movement.

See Figure 5-4.

1. Clean track rails to remove any sawdust and sap buildup every eight hours of operation.

8

Use a light-grade sandpaper or emery cloth to sand off any rust or other adhering particles from the rails.



CAUTION! Keep track rails free of rust. Formation of rust on the track rail in the areas where the cam bearings roll can cause rapid deterioration of the track rail's surface.

Lubricate the rails by wiping them with Dexron III ATF transmission fluid. Lubrication will help protect the rails from corrosive elements such as acid rain and/or moisture from nearby bodies of saltwater (if applicable). This lubrication is essential to maintain the integrity of the track rails and track rollers and to achieve long service life.

2. Remove sawdust from the track roller housings and lubricate the felt track wiper every twenty-five hours of operation.

25

Remove the track roller housing covers and brush any sawdust buildup from the housings.

Clean and lubricate the felt track wipers. Unbolt the middle track cover, remove from the sawmill and remove any sawdust buildup. Soak the felt wiper with Dexron III transmission fluid.



CAUTION! Reinstall the track wiper so that it lightly touches the track rail. If the wiper presses too firmly against the rail, it can cause the power feed to bind.

Soak the lower felt wipers with Dexron III transmission fluid. Apply oil to both wipers through the access holes in the wiper housings.

- 3.** Check the track scrapers as needed. Make sure the scrapers fit firmly against the rail. If a track scraper needs to be adjusted, loosen the screw, push the scraper downward until it fits firmly against the rail, and retighten the screw.

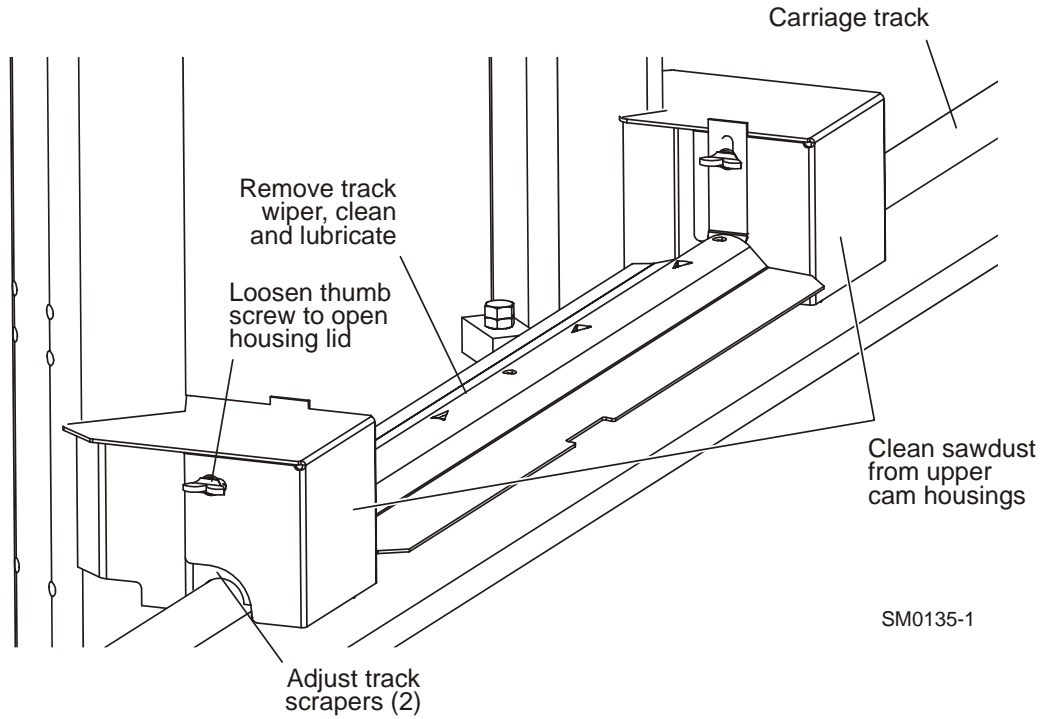

FIG. 5-4

5.5 Vertical Mast Rails



WARNING! Before performing service near moving parts such as blades, pulleys, motors, belts and chains, first turn the key switch to the OFF (#0) position and remove the key. If the key is turned on and moving parts activated, serious injury may result.



Clean and lubricate the vertical mast rails every 50 hours of operation. Clean with solvent and remove any rust with a light-grade sand paper or emery cloth. Lubricate the mast with motor oil or automatic transmission fluid (ATF).



CAUTION! Never use grease on the mast rails as it will collect sawdust.

5.6 Drum Switches



WARNING! Disconnect and lockout power before performing any service to the electrical system. For battery-powered equipment, disconnect the negative battery terminal cable. Failure to do so may result in injury and/or electrical system damage.



Lubricate the up/down and power feed drum switch contacts inside the control panel every fifty hours of operation. Use only contact grease supplied by Wood-Mizer. Remove the control panel cover. Use a cotton swab to apply grease to the switch contact ends.



WARNING! Drum switch grease contains Petroleum Hydrocarbon Lubricant. Eye and skin irritant. If introduced into eyes, flush with water for at least 15 minutes. If film or irritation persists, seek medical attention. Wash skin with soap and water. If ingested, do not induce vomiting - contact a physician. KEEP OUT OF THE REACH OF CHILDREN.

5.7 Miscellaneous



WARNING! Before performing service near moving parts such as blades, pulleys, motors, belts and chains, first turn the key switch to the OFF (#0) position and remove the key. If the key is turned on and moving parts activated, serious injury may result.

1. Oil all chains with Dexron III ATF every fifty hours of operation.

50



CAUTION! Do not use chain lube. It causes sawdust buildup in chain links.

2. Apply a thin film of a NLGI No. 2 grade lithium grease to the blade guide arm every fifty hours of operation to help prevent it from rusting.

50

3. Adjust the blade guide arm drive chain as necessary to prevent the arm from slipping. To adjust the chain, loosen the blade guide arm motor mounting plate bolts and slide the motor to take slack out of the chain.

AR

See **Figure 5-5**. Proper routing of the blade guide arm drive chain is shown below.

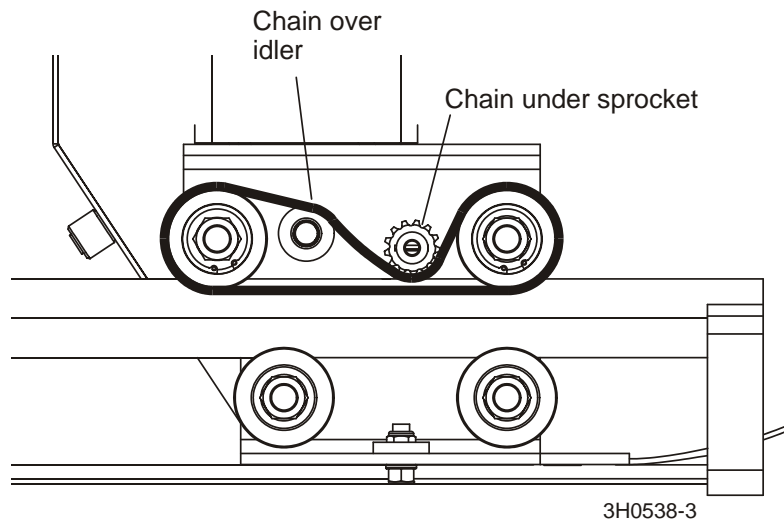

FIG. 5-5

4. Grease the clamp mechanism, loading arm, clutch handle pivot and side support pivots with a NLGI No. 2 grade lithium grease every fifty hours of operation.

50

5. Lubricate the board return pivot every fifty hours of operation with a NLGI No. 2 grade lithium grease. Apply grease to the grease fitting on the board return pivot tube.

50

6. Check the mill alignment every setup ([See Section 7](#)).
7. Make sure all safety warning decals are readable. Remove sawdust and dirt. Replace any damaged or unreadable decals immediately. Order decals from your Customer Service Representative.

5.8 Blade Tensioner



WARNING! Before performing service near moving parts such as blades, pulleys, motors, belts and chains, first turn the key switch to the OFF (#0) position and remove the key. If the key is turned on and moving parts activated, serious injury may result.

1. Lubricate the chrome rods of the tensioner system with a heavy duty teflon spray lubricant, such as Gunk L508, every fifty hours of operation.
2. Lubricate the tensioner screw handle with a NLGI No. 2 grade lithium grease as needed.

See Figure 5-6.

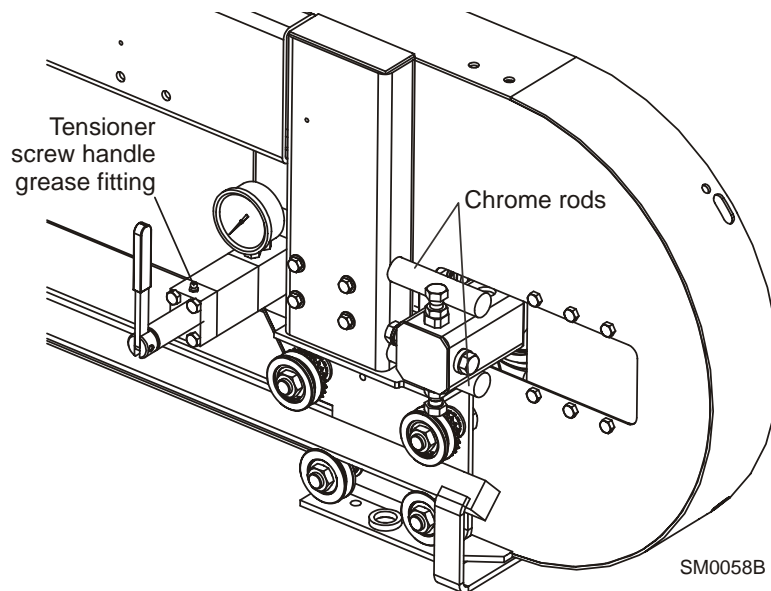

FIG. 5-6

See Figure 5-7. Add an Automatic Transmission Fluid (ATF) such as Dexron III ATF to the hydraulic blade tensioner as needed. To add enough fluid to completely fill the tensioner block:

1. Unscrew the tensioner handle to reveal 2" of thread. Remove the sawmill blade housing covers and blade.
2. Push the idle-side blade wheel/shaft housing all the way in to collapse the rear tensioner piston. Pull the idle-side blade wheel/shaft housing away from the tensioner.
3. There are two fill plugs provided on the tensioner. For easiest access, it is recommended to use the hole behind the gauge to refill the tensioner. Clean any dirt and debris from the plug area. Use a 7/16" wrench to remove the plug, making sure to keep the plug o-ring with the plug.
4. Use a small funnel, cup or squirt can to add hydraulic fluid through the fill plug hole until a puddle of fluid forms and is maintained over the fill hole. As you maintain the puddle, manually extend the rear piston. Be careful not to draw air into the tensioner. Use pliers to pull the rear piston if necessary, but only grip the outer 1/4" of the rear piston. Gripping or marring the surface beyond this point could result in seal damage and prevent the system from holding tension. Continue pulling out the piston as far as it will travel.
5. Reinsert the plug and thread 2-3 turns. Turn the tension handle clockwise until 6 or 7 threads show beyond the front piston block. Tighten the plug all the way.
6. Push the idle-side blade wheel/shaft housing all the way in to collapse the rear tensioner piston. If the piston does not extend at least 2" from the end of the tensioner block, repeat Steps 1-5.
7. Reinstall the blade and blade housing covers. If you have trouble installing a blade, it may be necessary to remove some fluid. Open the plug one turn and turn the tension handle in until some fluid is pushed out. Tighten the plug and retry.

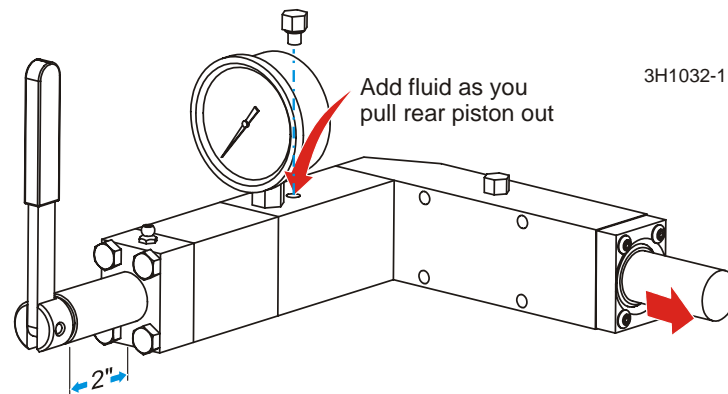

FIG. 5-7

5.9 Blade Wheel Belts



WARNING! Before performing service near moving parts such as blades, pulleys, motors, belts and chains, first turn the key switch to the OFF (#0) position and remove the key. If the key is turned on and moving parts activated, serious injury may result.



Rotate the blade wheel belts and check them for wear. Rotating the belts every 50 hours will provide longer belt life. Replace belts as necessary. Use only B57 belts manufactured by Goodyear or Browning.

5.10 Brake Strap Adjustment



WARNING! Before performing service near moving parts such as blades, pulleys, motors, belts and chains, first turn the key switch to the OFF (#0) position and remove the key. If the key is turned on and moving parts activated, serious injury may result.



Check the brake strap for wear every 200 hours of operation. Replace if damaged or worn.

Also check and adjust the brake strap after each drive belt adjustment, if the blade does not stop quickly, or unusual sounds occur when the brake is applied, or a sudden change is noticed in the clutch handle position when the clutch is disengaged. Adjust the brake strap if the drive belt jumps from the drive pulley when the clutch handle is disengaged.

1. To access the brake strap, remove the belt cover located underneath the engine.
2. Engage the clutch/brake lever.

See Figure 5-8.

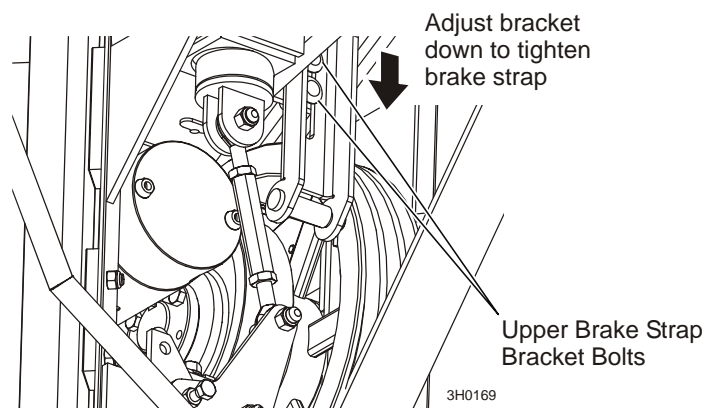

FIG. 5-8

3. Loosen the two nuts on the upper brake strap bracket. Slide the bracket and brake strap down 1/8" and retighten the bracket nuts.
4. Disengage the clutch. Check the drive belt fit in the drive pulley. You should just be able to pull the belt from the pulley. If the belt is still too loose, engage the clutch and repeat brake strap adjustments in 1/8" increments until the drive belt properly fits in the drive pulley with the clutch disengaged.

NOTE: Be careful to not overtighten. Overtightening will cause the drive belt to "grab" the pulley and can prevent the engine from starting properly.

5. Replace the belt cover.

5.11 Drive Belt Adjustment

NOTE: If your sawmill is equipped with the Autoclutch Option, see the [Autoclutch Option manual](#) for drive belt adjustment instructions.



WARNING! Disconnect and lockout power before performing any service to the electrical system. For battery-powered equipment, disconnect the negative battery terminal cable. Failure to do so may result in injury and/or electrical system damage.



WARNING! Before performing service near moving parts such as blades, pulleys, motors, belts and chains, first turn the key switch to the OFF (#0) position and remove the key. If the key is turned on and moving parts activated, serious injury may result.



WARNING! Do not for any reason adjust the engine drive belts or belt support bracket with the engine running. Doing so may result in serious injury.

See Table 5-2. See the table below for drive belt tension specifications for your model sawmill.

Engine/Motor	After First	Then Every	Belt Tension
ALL	5 hrs	50 hrs	7/16" (11mm) deflection with 18 lbs. of deflection force ¹

TABLE 5-2

¹ If installing a new drive belt, initially tension the belt to 24 lbs. then 18 lbs. for subsequent adjustments.

1. Remove the two belt covers located underneath the engine.
2. Loosen the drive belt turnbuckle jam nuts. Turn the turnbuckle counterclockwise (as viewed from the top) to tighten the belt, clockwise to loosen the belt.

See Figure 5-9.

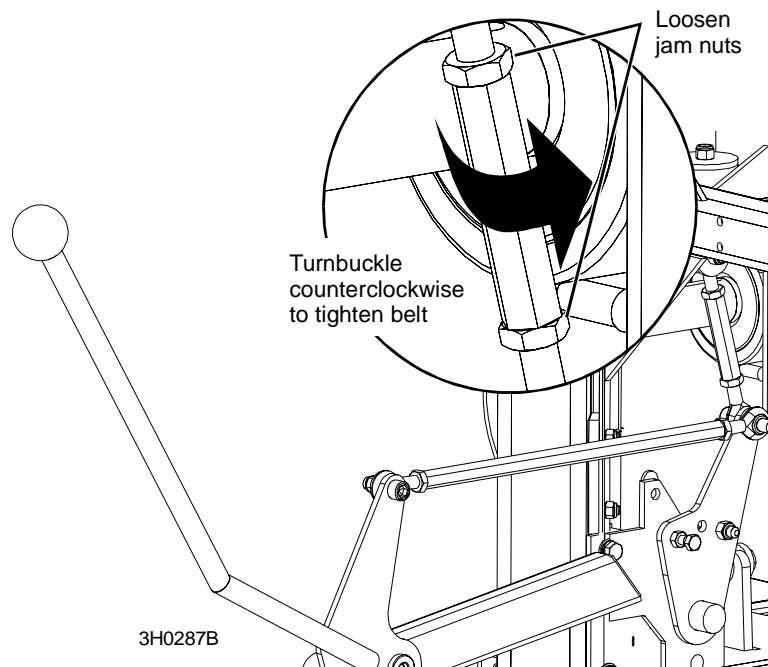

FIG. 5-9

3. Place a wrench on the flats at the top of the turnbuckle. Use a second wrench to turn the bottom-most jam nut clockwise (as viewed from the bottom) to tighten the belt, counterclockwise to loosen the belt.
4. After tensioning the drive belt, disengage the clutch/brake lever and check the fit of the belt in the drive pulley. You should just be able to pull the belt from the drive pulley. If the belt is too loose, it may jump from the drive pulley when the belt is disengaged. Adjusting the brake strap controls the drive belt fit in the drive pulley when the clutch/brake lever is disengaged ([See Section 5.10](#)).
5. **Gas/Diesel Engines Only:** After tensioning the drive belt, check throttle cable tension and adjust if necessary. The throttle cable should be tensioned just enough so that the engine revs as soon as the clutch/brake handle is engaged. The throttle linkage should NOT affect engine RPM while the clutch/brake handle is disengaged. **NOTE:** A properly adjusted throttle will extend the cable spring 1/4" to 3/8" (6.4 - 9.5 mm) when running and have a slight amount of slack in the cable when idling. Always be sure to check the drive belt support after adjusting drive belt tension.



Periodically check the drive belt for wear. Replace any damaged or worn belts as needed.

AR

Adjust the drive belt support as needed. The drive belt support is designed to extend belt life. The bracket should be adjusted to NOT touch the drive belt when the clutch handle is engaged (down position), AND to hold the drive belt away from the engine pulley when the clutch handle is disengaged (up position).

See Figure 5-10. To adjust the drive belt support:

1. Make sure the motor is not running. Loosen the adjustment bolts.
2. Position the bracket so that the prong is close to, but does not touch, the drive belt with the clutch handle engaged.
3. Retighten the adjustment bolts 25-27 pound feet (34-37 newton meters).

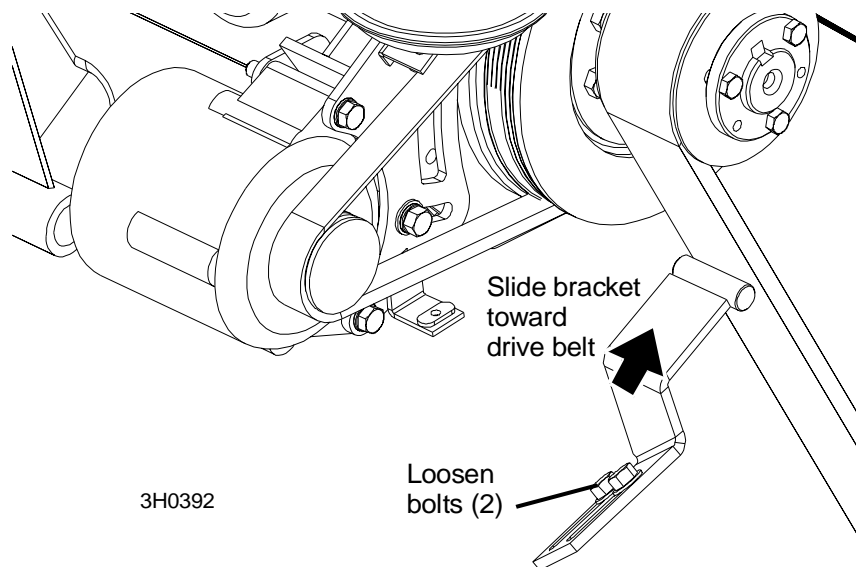

FIG. 5-10

5.12 Hydraulic System



WARNING! Disconnect and lockout power before performing any service to the electrical system. For battery-powered equipment, disconnect the negative battery terminal cable. Failure to do so may result in injury and/or electrical system damage.

1. Check the hydraulic fluid level every fifty hours of operation. Add fluid as necessary. The level in the hydraulic pump should be 3/4" (19mm) from the top with all cylinders collapsed.

If humidity is a problem or the mill is used outside in humid weather, drain and replace two quarts (.95 liters) of fluid every six months. This will drain any accumulated water and help prevent pump failure due to water ingestion. It also will prevent excessive fluid wear and allow the fluid to maintain its hot end performance. If humidity is not a problem, drain and replace one gallon (3.8 liters) of fluid every year to prevent fluid wear.

See Figure 5-11. If you are operating in temperatures -20° to 100° F (-29° to 38° C), use an all-weather hydraulic fluid such as Conoco MV32. For alternate fluids and/or other temperature ranges, refer to the chart below. Operating above the recommended temperature range of a fluid could result in excessive pump wear. Operating below the recommended temperature range could result in reduced hydraulic cylinder speed. To change fluid types, replace one gallon of the current fluid with one gallon of the alternate fluid.

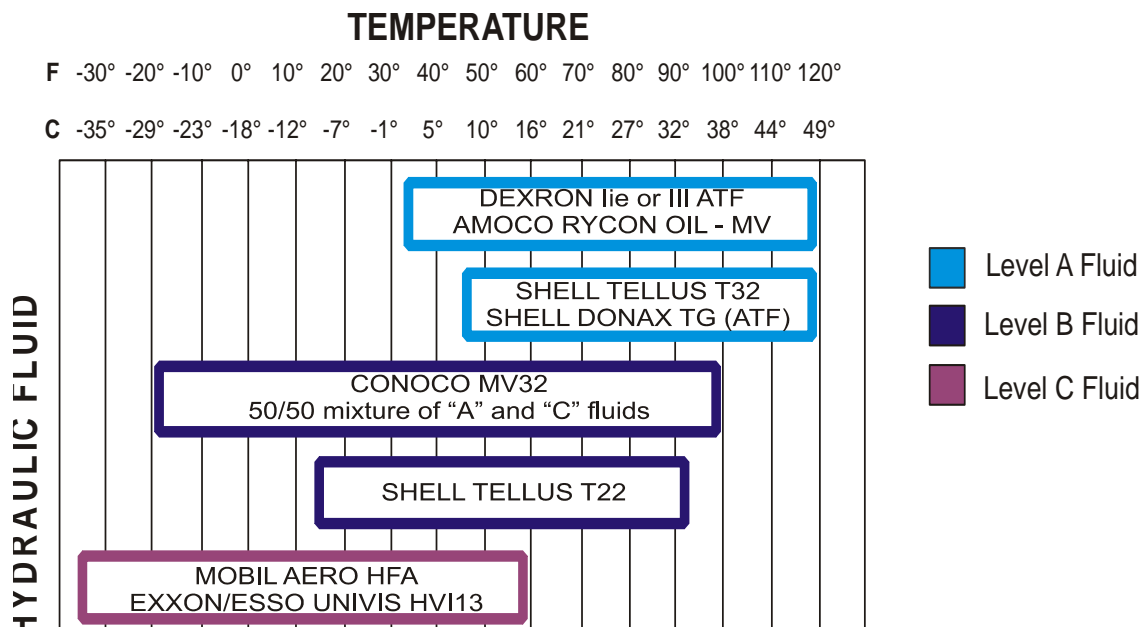

FIG. 5-11



2. Replace the hydraulic system cartridge filter every 500 hours of operation.

3. Inspect the hydraulic pump motor brushes every 750 hours of operation. Remove brush dust and replace the brushes if they worn to a length of 1/4" or shorter.

750



CAUTION! Do not operate the hydraulic system if the pump motor brushes are worn shorter than 1/4". Damage to the pump motor may result.

4. Periodically check all hydraulic lines and fitting as needed. Replace as necessary.

5.13 Drive Bearing



WARNING! Before performing service near moving parts such as blades, pulleys, motors, belts and chains, first turn the key switch to the OFF (#0) position and remove the key. If the key is turned on and moving parts activated, serious injury may result.



Drain and refill the fluid in the drive-side cylinder bearing housing every 500 hours of operation.

Disconnect the oil level view hose from the fitting at the top of the bearing housing. With the fitting at the bottom of the bearing housing still connected, allow oil to drain from the oil level view hose. Once drained, pour fresh Automatic Transmission Fluid (ATF) such as Dexron III ATF into the hose until the oil level is in the acceptable range as indicated on the gauge decal. Reconnect the hose to the top fitting.

See Figure 5-12.

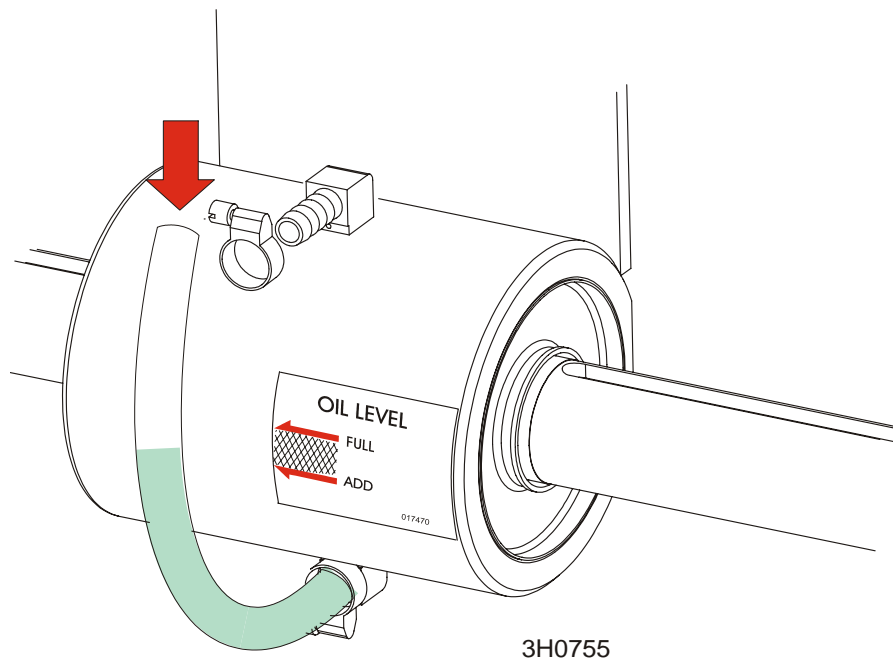



FIG. 5-12

5.14 Up/Down System

 **WARNING!** Before performing service near moving parts such as blades, pulleys, motors, belts and chains, first turn the key switch to the OFF (#0) position and remove the key. If the key is turned on and moving parts activated, serious injury may result.

 **WARNING!** Disconnect and lockout power before performing any service to the electrical system. For battery-powered equipment, disconnect the negative battery terminal cable. Failure to do so may result in injury and/or electrical system damage.

AR

Adjust the up/down chain tension as needed. Measure chain tension with the head all the way to the top of the vertical mast. Secure the head with a chain at the top. Find the chain adjusting bolt at the bottom of the mast. Use the adjustment nut to adjust the bolt until the center of the chain can be deflected 3/4" (1.9cm) forward *and* 3/4" (1.9cm) backward with a 5 lb. (2.3 Kg) deflection force.

 **WARNING!** Always secure the saw head with a 5/16" chain with at least 1900 lbs. working load capacity before adjusting the up/down chain. The cutting head may fall, causing severe injury or death.

 **CAUTION!** Do not over-tension the chain. Over-tensioning the chain may lead to early failure of the gear reducer.

See Figure 5-13.

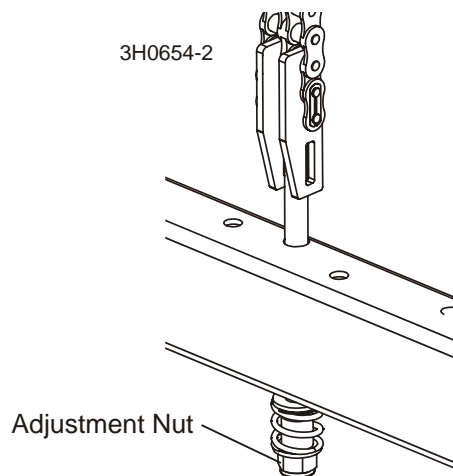

FIG. 5-13

- 1000 ▶ 1. Grease the up/down gear reducer shaft bearing with a NLGI No. 2 grade lithium grease every 1000 hours of operation.

See Figure 5-14.

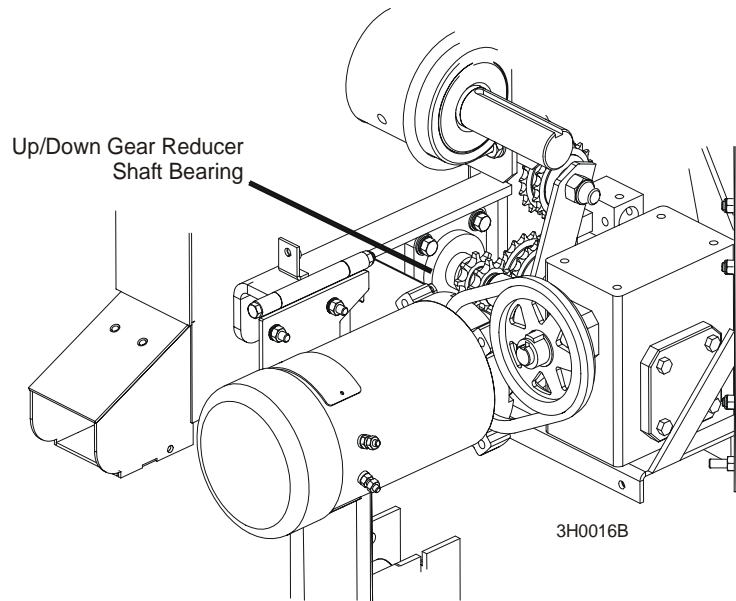



FIG. 5-14

2. The up/down motor features a spring-loaded belt design. Belt tension is automatically maintained and requires no adjustment. Replace the belt when adequate belt tension can no longer be obtained.

 **WARNING!** Always secure the saw head with a 5/16" chain with at least 1900 lbs. working load capacity before removing the up/down motor belt. The cutting head may fall, causing severe injury or death.

AR ▶ Periodically check the belt for wear. Replace any damaged or worn belts as needed.

3. Check the up/down gearbox oil level. Add a synthetic gear oil such as Mobil SHC 634 as needed.

Drain and refill the gearbox with 24 ounces of oil after every 5000 hours of sawmill operation or every 2 years, whichever comes first.

Wood-Mizer offers replacement gear oil in 8 ounce bottles.

5

Maintenance

Up/Down System

4. Inspect the up/down motor brushes every 750 hours of operation. Remove brush dust and replace the brushes if they worn to a length of 5/8" or shorter.

750



CAUTION! Do not operate the up/down system if the motor brushes are worn shorter than 5/8". Damage to the up/down motor may result.

5.15 Charging The Battery



DANGER! Batteries expel explosive gases. Keep sparks, flames, burning cigarettes, or other ignition sources away at all times. Always wear safety goggles and a face shield when working near batteries. Failure to do so will cause serious injury.¹



WARNING! Battery posts, terminals and related accessories contain lead and lead compounds, chemicals known to the State of California to cause cancer and reproductive harm. Wash hands after handling.



WARNING! Charge the battery in a well ventilated area. Do not attempt to charge a frozen battery.

Use extreme care to avoid spilling or splashing electrolyte (which is dilute sulfuric acid) as it can destroy clothing and burn the skin. If electrolyte is spilled or splashed on clothing or the body, it should be neutralized immediately and then rinsed with clean water. A solution of baking soda, or household ammonia, and water may be used as a neutralizer.

Electrolyte splashed into the eyes is extremely dangerous. If this should happen, force the eye open and flood it with cool, clean water for approximately fifteen minutes. A doctor should be called immediately when the accident occurs and “on-the-spot” medical attention given if possible. If a doctor cannot come to the scene of the accident immediately, follow his instructions concerning actions to take. Do not add eye drops or other medication unless advised to do so by the doctor. Do not place a battery or acid within the reach of children. If acid (electrolyte) is taken internally drink large quantities of water or milk. Follow with milk of magnesia, beaten egg or vegetable oil. Call a physician immediately.

If electrolyte is spilled or splashed on any surface of the machine, it should be neutralized and rinsed with clean water.



CAUTION! Do not overcharge the battery. Overcharging may reduce the overall service life of the battery.

¹ Battery Council International, copyright 1987

CAUTION! Be sure the battery is fully charged before transporting the sawmill. If the battery is not fully charged, excessive vibration could reduce the overall service life of the battery.

NOTE: A fuse terminal extension stud is provided in the fuse box. The extension may be used to temporarily connect a battery charger or jumper cables to raise the saw head from the towing position so the battery box lid can be removed. [See Section 6.11](#) for instructions concerning the fuse terminal extension stud.

1. Raise the saw head to access the battery box.
2. Turn the key to the OFF (#0) position and remove the key.
3. Remove the two wing nuts and flat washers holding the battery box lid to the battery box.
4. Remove the battery box lid.
5. Clean the battery terminals if necessary.
6. Connect the positive charger/jumper cable directly to the positive battery terminal.
7. Connect the negative charger/jumper cable to a grounded metal surface.
8. Follow the instructions supplied with your specific battery charger.



IMPORTANT: Be careful not to overcharge the battery, especially when using a high-rate or “boost” charger (40 amps or higher). These are intended to quickly charge a good battery that is discharged. They are not intended for unattended or long-term charging.

9. After the battery is completely recharged, remove the negative charger/jumper cable from ground.
10. Remove the positive charger/jumper cable from the battery.
11. Replace the battery box lid and replace the flat washers and wing nuts.

5.16 Power Feed



WARNING! Before performing service near moving parts such as blades, pulleys, motors, belts and chains, first turn the key switch to the OFF (#0) position and remove the key. If the key is turned on and moving parts activated, serious injury may result.



WARNING! Disconnect and lockout power before performing any service to the electrical system. For battery-powered equipment, disconnect the negative battery terminal cable. Failure to do so may result in injury and/or electrical system damage.

1. Adjust the power feed belt as needed. When the power feed belt gets loose, it will begin slipping. This causes the carriage to not move forward when cutting. To retighten the belt:

See Figure 5-15. Remove the four cover bolts and belt cover and measure the belt tension. The belt should be tightened so there is 1/8" (3 mm) deflection with a 7 lb. (3.2 Kg) deflection force. To adjust the belt tension, loosen the four motor mount bolts. Place a wrench on the jam nut and turn the adjustment bolt clockwise to tighten the belt. Retighten the motor bolts and replace the feed motor cover.

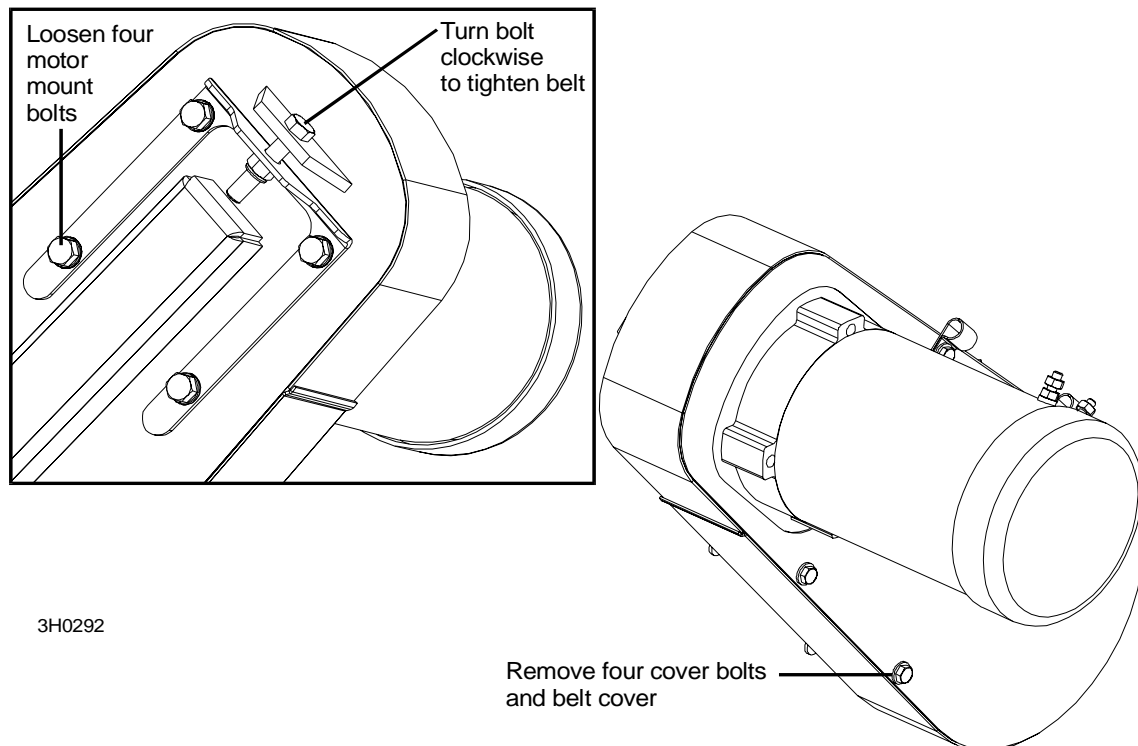

FIG. 5-15

Periodically check the belt for wear. Replace any damaged or worn belts as needed.

AR

2. Adjust the power feed chain as needed. Measure the power feed chain tension with the saw head all the way toward the front of the mill. Use the two lock nuts at the rear of the mill to tighten or loosen the power feed chain. Adjust the chain until it measures 7 to 8 inches (17.8 to 20.3 cm) from the top of the top rail at its lowest point.



CAUTION! Do not overtighten the feed chain. Damage to the power feed motor may result.

See Figure 5-16.

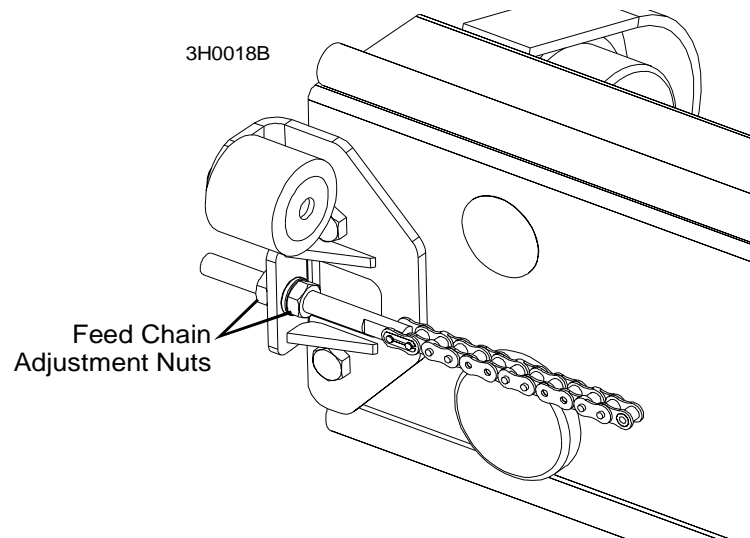

FIG. 5-16

See Figure 5-17. Refer to the diagram for power feed chain routing instructions.

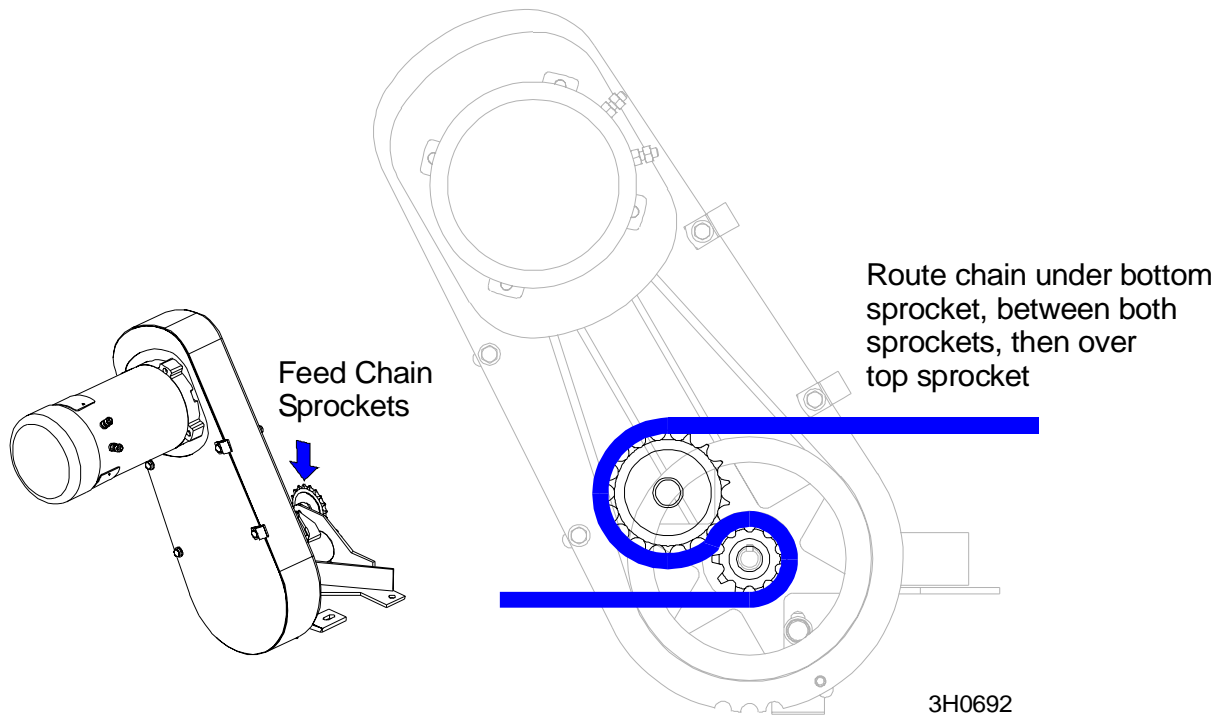

FIG. 5-17

3. Inspect the power feed motor brushes every 750 hours of operation. Remove brush dust and replace the brushes if they worn to a length of 5/8" or shorter.

750



CAUTION! Do not operate the power feed system if the feed motor brushes are worn shorter than 5/8". Damage to the feed motor may result.

MAINTENANCE LOG

(Check Engine And Option Manuals For Additional Maintenance Procedures)

Check Blade Guide Block/Roller Wear	See Section 5.2	Daily - Every Blade Change	DAILY MAINTENANCE PROCEDURES
Remove Excess Sawdust From Blade Wheel Housings And Sawdust Chute	See Section 5.3	Daily - Every Blade Change	
Inspect Fingers Inside Sawdust Chute	See Section 5.3	Daily - Every Blade Change	
Clean Sawdust From Hydraulic Loader Fuses , Battery Box Lid & Track Cover	See Section 5.3	Daily - Every 8 Hours	
Clean And Lubricate Track	See Section 5.4	Daily - Every 8 Hours	
Remove Sawdust From Upper Track Roller Housings	See Section 5.4	Bi-Weekly - Every 25 Hours	
Check Blade Guide Block Spacing	See Section 5.2	Bi-Weekly - Every 25 Hours	
Clean And Lubricate Upper Track Wiper	See Section 5.4	Bi-Weekly - Every 25 Hours	

PROCEDURE	REFERENCE	TOTAL HOURS OF OPERATION									
		FILL IN THE DATE AND THE MACHINE HOURS AS YOU PERFORM EACH PROCEDURE. A SHADED BOX INDICATES MAINTENANCE IS NOT NEEDED AT THIS TIME.									
		50 HRS	100 HRS	150 HRS	200 HRS	250 HRS	300 HRS	350 HRS	400 HRS	450 HRS	500 HRS
Clean & lube mast rails	See Section 5.5										
Lubricate drum switches	See Section 5.6										
Grease pivot points and bearings/Oil chains	See Section 5.7										
Lubricate blade tensioner handle and rods	See Section 5.8										
Rotate drive/idle blade wheel belts/Check for wear	See Section 5.9										
Check brake strap tension	See Section 5.10										
Check belt tensions	See Section 5.11 See Section 5.14 See Section 5.16										
Check blade throat screw	See Section 5.2										
Replace cylinder drive bearing fluid	See Section 5.13										
Check feed & up/down chain tensions	See Section 5.14 See Section 5.16										
Check up/down gear box fluid level	See Section 5.14										
Inspect hydraulic lines & fittings	See Section 5.12										
Check hydraulic fluid level	See Section 5.12										
Replace hydraulic system filter	See Section 5.12										
Inspect hydraulic pump, power feed and up/down motor brushes	See Section 5.12 See Section 5.14 See Section 5.16										
Grease up/down shaft bearing	See Section 5.14										

MAINTENANCE LOG

PROCEDURE	REFERENCE	TOTAL HOURS OF OPERATION									
		FILL IN THE DATE AND THE MACHINE HOURS AS YOU PERFORM EACH PROCEDURE. A SHADED BOX INDICATES MAINTENANCE IS NOT NEEDED AT THIS TIME.									
		550 HRS	600 HRS	650 HRS	700 HRS	750 HRS	800 HRS	850 HRS	900 HRS	950 HRS	1000 HRS
Clean & lube mast rails	See Section 5.5										
Lubricate drum switches	See Section 5.6										
Grease pivot points and bearings/Oil chains	See Section 5.7										
Lubricate blade tensioner handle and rods	See Section 5.8										
Rotate drive/idle blade wheel belts/Check for wear	See Section 5.9										
Check brake strap tension	See Section 5.10										
Check belt tensions	See Section 5.11 See Section 5.14 See Section 5.16										
Check blade throat screw	See Section 5.2										
Replace cylinder drive bearing fluid	See Section 5.13										
Check feed & up/down chain tensions	See Section 5.14 See Section 5.16										
Check up/down gear box fluid level	See Section 5.14										
Inspect hydraulic lines & fittings	See Section 5.12										
Check hydraulic fluid level	See Section 5.12										
Replace hydraulic system filter	See Section 5.12										
Inspect hydraulic pump, power feed and up/down motor brushes	See Section 5.12 See Section 5.14 See Section 5.16										
Grease up/down shaft bearing	See Section 5.14										

MAINTENANCE LOG

PROCEDURE	REFERENCE	TOTAL HOURS OF OPERATION									
		FILL IN THE DATE AND THE MACHINE HOURS AS YOU PERFORM EACH PROCEDURE. A SHADED BOX INDICATES MAINTENANCE IS NOT NEEDED AT THIS TIME.									
		1050 HRS	1100 HRS	1150 HRS	1200 HRS	1250 HRS	1300 HRS	1350 HRS	1400 HRS	1450 HRS	1500 HRS
Clean & lube mast rails	See Section 5.5										
Lubricate drum switches	See Section 5.6										
Grease pivot points and bearings/Oil chains	See Section 5.7										
Lubricate blade tensioner handle and rods	See Section 5.8										
Rotate drive/idle blade wheel belts/Check for wear	See Section 5.9										
Check brake strap tension	See Section 5.10										
Check belt tensions	See Section 5.11 See Section 5.14 See Section 5.16										
Check blade throat screw	See Section 5.2										
Replace cylinder drive bearing fluid	See Section 5.13										
Check feed & up/down chain tensions	See Section 5.14 See Section 5.16										
Check up/down gear box fluid level	See Section 5.14										
Inspect hydraulic lines & fittings	See Section 5.12										
Check hydraulic fluid level	See Section 5.12										
Replace hydraulic system filter	See Section 5.12										
Inspect hydraulic pump, power feed and up/down motor brushes	See Section 5.12 See Section 5.14 See Section 5.16										
Grease up/down shaft bearing	See Section 5.14										

MAINTENANCE LOG

PROCEDURE	REFERENCE	TOTAL HOURS OF OPERATION									
		FILL IN THE DATE AND THE MACHINE HOURS AS YOU PERFORM EACH PROCEDURE. A SHADED BOX INDICATES MAINTENANCE IS NOT NEEDED AT THIS TIME.									
		1550 HRS	1600 HRS	1650 HRS	1700 HRS	1750 HRS	1800 HRS	1850 HRS	1900 HRS	1950 HRS	2000 HRS
Clean & lube mast rails	See Section 5.5										
Lubricate drum switches	See Section 5.6										
Grease pivot points and bearings/Oil chains	See Section 5.7										
Lubricate blade tensioner handle and rods	See Section 5.8										
Rotate drive/idle blade wheel belts/Check for wear	See Section 5.9										
Check brake strap tension	See Section 5.10										
Check belt tensions	See Section 5.11 See Section 5.14 See Section 5.16										
Check blade throat screw	See Section 5.2										
Replace cylinder drive bearing fluid	See Section 5.13										
Check feed & up/down chain tensions	See Section 5.14 See Section 5.16										
Check up/down gear box fluid level	See Section 5.14										
Inspect hydraulic lines & fittings	See Section 5.12										
Check hydraulic fluid level	See Section 5.12										
Replace hydraulic system filter	See Section 5.12										
Inspect hydraulic pump, power feed and up/down motor brushes	See Section 5.12 See Section 5.14 See Section 5.16										
Grease up/down shaft bearing	See Section 5.14										

MAINTENANCE LOG

PROCEDURE	REFERENCE	TOTAL HOURS OF OPERATION									
		FILL IN THE DATE AND THE MACHINE HOURS AS YOU PERFORM EACH PROCEDURE. A SHADED BOX INDICATES MAINTENANCE IS NOT NEEDED AT THIS TIME.									
		2050 HRS	2100 HRS	2150 HRS	2200 HRS	2250 HRS	2300 HRS	2350 HRS	2400 HRS	2450 HRS	2500 HRS
Clean & lube mast rails	See Section 5.5										
Lubricate drum switches	See Section 5.6										
Grease pivot points and bearings/Oil chains	See Section 5.7										
Lubricate blade tensioner handle and rods	See Section 5.8										
Rotate drive/idle blade wheel belts/Check for wear	See Section 5.9										
Check brake strap tension	See Section 5.10										
Check belt tensions	See Section 5.11 See Section 5.14 See Section 5.16										
Check blade throat screw	See Section 5.2										
Replace cylinder drive bearing fluid	See Section 5.13										
Check feed & up/down chain tensions	See Section 5.14 See Section 5.16										
Check up/down gear box fluid level	See Section 5.14										
Inspect hydraulic lines & fittings	See Section 5.12										
Check hydraulic fluid level	See Section 5.12										
Replace hydraulic system filter	See Section 5.12										
Inspect hydraulic pump, power feed and up/down motor brushes	See Section 5.12 See Section 5.14 See Section 5.16										
Grease up/down shaft bearing	See Section 5.14										

MAINTENANCE LOG

PROCEDURE	REFERENCE	TOTAL HOURS OF OPERATION									
		FILL IN THE DATE AND THE MACHINE HOURS AS YOU PERFORM EACH PROCEDURE. A SHADED BOX INDICATES MAINTENANCE IS NOT NEEDED AT THIS TIME.									
		2550 HRS	2600 HRS	2650 HRS	2700 HRS	2750 HRS	2800 HRS	2850 HRS	2900 HRS	2950 HRS	3000 HRS
Clean & lube mast rails	See Section 5.5										
Lubricate drum switches	See Section 5.6										
Grease pivot points and bearings/Oil chains	See Section 5.7										
Lubricate blade tensioner handle and rods	See Section 5.8										
Rotate drive/idle blade wheel belts/Check for wear	See Section 5.9										
Check brake strap tension	See Section 5.10										
Check belt tensions	See Section 5.11 See Section 5.14 See Section 5.16										
Check blade throat screw	See Section 5.2										
Replace cylinder drive bearing fluid	See Section 5.13										
Check feed & up/down chain tensions	See Section 5.14 See Section 5.16										
Check up/down gear box fluid level	See Section 5.14										
Inspect hydraulic lines & fittings	See Section 5.12										
Check hydraulic fluid level	See Section 5.12										
Replace hydraulic system filter	See Section 5.12										
Inspect hydraulic pump, power feed and up/down motor brushes	See Section 5.12 See Section 5.14 See Section 5.16										
Grease up/down shaft bearing	See Section 5.14										

SECTION 6 TROUBLESHOOTING GUIDE

6.1 Sawing Problems



WARNING! Before performing service near moving parts such as blades, pulleys, motors, belts and chains, first turn the key switch to the OFF (#0) position and remove the key. If the key is turned on and moving parts activated, serious injury may result.

PROBLEM	CAUSE	SOLUTION
Blades Dull Quickly	Dirty logs	Clean or debark logs, especially on entry side of the cut
	When grinding teeth, heating too much and causing teeth to soften	Grind just enough metal to restore sharpness to the teeth. Use water/coolant while sharpening blade
	Poor sharpening techniques	Make sure the tip is being sharpened completely (See Sharpener Manual)
Blades Break Prematurely	Poor sharpening techniques	See Sharpener Manual
	Rubber belts on blade wheels worn to a point that blade contacts metal pulley - look for shiny spots on edge of wheels	Change blade wheel belts (B-57)
	Tension too tight	Tension blade to recommended specifications
Blade Does Not Track Right on Drive Wheel	Cant adjustment is incorrect	Readjust
	Flat/worn belts	Replace B-57 belts
Blade Guides Do Not Spin While Cutting	Frozen bearings	Replace bearings
Blade Does Not Stop Immediately After Disengaging	Brake strap too loose	Adjust brake strap
Drive Belts Come Off Pulleys When Disengaging Blade	Brake strap too loose	Adjust brake strap
	Brake drum misaligned	Realign on drive shaft
	Brake strap tightened with one edge too loose and one edge too tight	Adjust brake strap
Drive Belts Wear Prematurely or Jump	Engine/motor and drive pulleys out of alignment	Align pulleys See Section 6.6.

PROBLEM	CAUSE	SOLUTION
Boards Thick Or Thin On Ends Or Middle Of Board.	Stress in log which causes log to not lay flat on the bed.	After log has been squared, take equal cuts off opposing sides. Take a board off the top. Turn the log 180 degrees. Take a board off. Repeat, keeping the heart in the middle of the cant, and making it your last cut.
	Set in teeth.	Resharpener and reset blade.
Height Adjustment Jumps or Stutters When Moving Up or Down.	Bed rails misaligned.	Realign sawmill.
	Up/down chain improperly adjusted.	Adjust up/down chain.
	Vertical wear pads are too tight.	Adjust pads.
	Up/down belt loose.	Replace belt.
Lumber Is Not Square	Vertical side supports not square to bed	Adjust side supports.
	Blade not parallel to bed rails	Adjust bed rails parallel to blade.
	Sawdust or bark between cant and bed rails	Remove particles
Sawdust Builds Up On Track	Tooth set problems	Resharpener and reset blade
	Excessive oiling	Do not oil track
	Track wipers worn	Adjust wipers to firmly contact track
	Track is sticky	Clean track with solvent and apply silicone spray
Wavy Cuts	Excessive feed	Slow feed rate
	Improperly sharpened blade (This will be the problem 99% of the time!)	Resharpener blade (See Sharpener Manual - read entire manual!)
	Blade guides improperly adjusted	Adjust blade guides.
	Sap buildup on blade	Use Water Lube.
	Tooth set problem	Resharpener and reset blade

6.2 Electrical Problems



WARNING! Before performing service near moving parts such as blades, pulleys, motors, belts and chains, first turn the key switch to the OFF (#0) position and remove the key. If the key is turned on and moving parts activated, serious injury may result.



WARNING! Disconnect and lockout power before performing any service to the electrical system. For battery-powered equipment, disconnect the negative battery terminal cable. Failure to do so may result in injury and/or electrical system damage.

PROBLEM	CAUSE	SOLUTION
Up/down Excessively Slow.	Up/down belt loose.	Adjust belt to be as loose as possible without slipping.
	Vertical wear pads too tight.	Adjust pads.
	Worn up/down motor or motor brushes.	Replace up/down motor or motor brushes.
Up/down Or Power Feed Motors Do Not Work.	Worn/dirty contacts in drum switch.	Replace switch or remove control panel cover and clean contacts.
	Bad key switch.	Replace key switch.
	Circuit breaker.	Reset breaker in control box (See Section 6.3).
	Burned-out motor.	Replace motor.
Power Feed Motor Does Not Work.	Bad connection on battery post or loose wire.	Check for loose wire or terminal connections.
	Sawdust buildup in the power feed pulleys.	Sawdust buildup puts mechanical bind on power feed which causes automatic motor protection circuit to activate. Remove sawdust from pulleys and operate normally. If motor does not operate after sawdust removal, reset circuit breaker on the front of the control box.
Up/Down Or Power Feed Switches Remain Engaged When Switch Is Released.	Worn or dirty contacts in drum switch.	Manually move the power feed or up/down switch back to neutral or "off" position. Replace drum switch or remove control panel cover and clean and lubricate contacts NOTE: Use only contact grease supplied by Wood-Mizer.
	Drum switch spring broken.	Manually move the power feed or up/down switch back to neutral or "off" position. Replace drum switch spring.

PROBLEM	CAUSE	SOLUTION
Up/Down Or Power Feed Motors Overheat And Lose Power.	System overload or bind occurred.	Correct problem (See Section 6.4). Allow motor to cool before restarting.
	Normal operation factors exceeded (eg: up/down control jockeyed excessively).	Allow motor to cool before restarting.
Everything Works And Then Cuts Out - Works Again.	Bad battery, fuse, or ground connection.	Check and tighten connections.
Nothing Works Electrically.	Dead battery.	Check for short circuit or turn OFF key.
	Blown fuse.	Replace.
	Corrosion on battery post.	Remove connection and clean posts.
Battery Will Not Stay Charged.	Key switch left ON.	Turn switch OFF when not in use.
	Short in system.	Visually check for bare wires and/or have checked.
	Charging system not functioning.	Have charging system checked by authorized dealer.
	Bad battery cells.	Check fluid levels and add proper solution
Intermittent Or Permanent Loss Of Accessory Motor Functions Occurs (Up/down, Fwd/rev, Blade Guide Functions Do Not Work).	Idle improper.	Adjust low end RPM per engine manual.
	Loose alternator belt.	Check belt tension and tighten if necessary.
	Loose connections at LED circuit board or alternator.	Check and tighten connections.
	Bad connections at accessory solenoid or bad solenoid.	Check all connections at accessory solenoid. If connections are good, replace solenoid.

6.3 Power Feed Problems



WARNING! Disconnect and lockout power before performing any service to the electrical system. For battery-powered equipment, disconnect the negative battery terminal cable. Failure to do so may result in injury and/or electrical system damage.

NOTE: The power feed circuit board is equipped with LED lights to help determine if the circuit board or feed rate switch are the cause of any feed problems you may encounter. [See Section 6.4](#) for instructions.

PROBLEM	CAUSE	SOLUTION
Power Feed Is Jerky At Low Speeds Or Does Not Move Until Speed Is Above Halfway Mark.	Drum switch is dirty.	Clean drum switch and lubricate with contact grease supplied by Wood-Mizer.
	Drum switch contacts are bad	Check that contacts are in good condition and positively close circuit.
	Components are loose or wires are broken.	Replace or repair PC board.
Power Feed Is Jerky When Shaft Of Feed Rate Dial Is Moved Back And Forth.	Variable speed switch is bad - perform the variable speed switch test.	Replace variable speed switch.
Power Feed Is Jerky, But Power Feed Motor Runs Properly At All Speeds.	Problem is mechanical.	Refer to the Mechanical Test.
Power Feed Is Sluggish, Trips Circuit Breaker Or Current Limit.	Sawdust buildup in power feed cover.	Remove power feed belt cover and remove sawdust.

PROBLEM	CAUSE	SOLUTION
Power Feed Motor Overheats.	Middle track oiler is dragging.	Clean middle track oiler and lubricate with 30-weight oil or ATF (Automatic Transmission Fluid) such as Dexron II. Allow motor to cool before restarting.
	Ground is not level.	Level mill with carpenter's level. Allow motor to cool before restarting.
	Track roller bearing drag is excessive.	Lubricate bearings; Replace tight bearings. Allow motor to cool before restarting.
	Lower track rollers are not aligned properly.	Check stop clearance from lower track rail. Allow motor to cool before restarting.
	Chain is dragging.	Make sure chain is centered on idler; Clean and lubricate chain; Adjust chain tension. Allow motor to cool before restarting.
	Chain is improperly tensioned.	Adjust chain tension. Allow motor to cool before restarting.
	Operator Seat option load is excessive.	Check seat bearings for freedom of movement; Loosen clamping screw 1/4 turn. Allow motor to cool before restarting.
	Power feed is binding.	Adjust belt tension; Check condition of belt, pulleys, bearings, and sprocket; Check motor for ground fault. Allow motor to cool before restarting.
	Saw head load is excessive.	Avoid unnecessary modifications to saw heads that would give them extra weight. Allow motor to cool before restarting.
	Blade is dull or improperly set.	Use proper blade maintenance procedures (See Sharpener or Toothsetter manual). Allow motor to cool before restarting.

6.4 Power Feed Circuit Troubleshooting

LT30HD Super *Rev. J8.00 - J8.09*
LT40HD Super *Rev. J8.00 - K3.02*

LED lights are provided on the control module to help troubleshoot any feed problems you may encounter.

See **Figure 6-1**. The lights can be viewed by removing the rear control box panel.

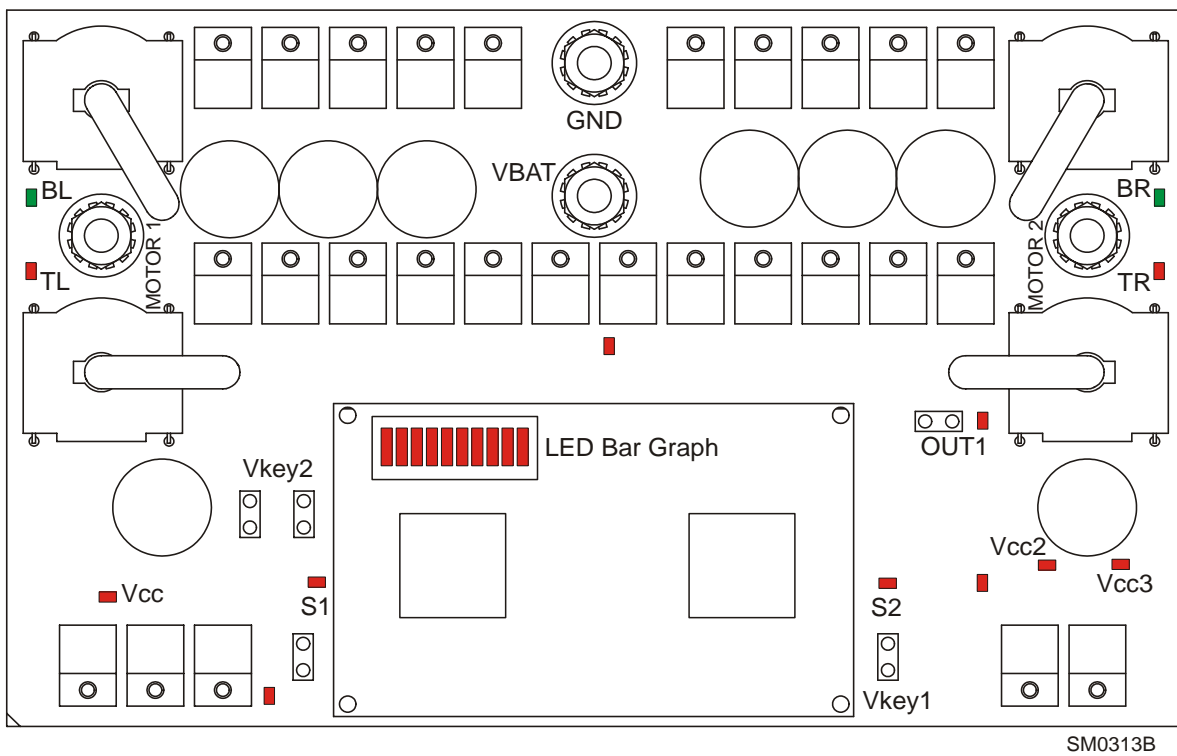

FIG. 6-1

If you have trouble determining the problem indicated by the lights, please note which lights are on and call customer service for assistance.

BL, TL, BR, TR - The two red and two green lights indicate different states of sawmill operation. Several different states of the lights in three positions of the power feed drum switch with the feed rate dial switch all the way up are shown below.

See Table 6-1. The drum switch positions and light states with the feed rate dial switch all the way up are shown below.

Power Feed Drum Switch Position	BL	TL	BR	TR
FORWARD	On	Off	Off	On
REVERSE	Off	On	On	Off
NEUTRAL	On	On	On	On

TABLE 6-1

Please contact Customer Service for assistance if necessary when troubleshooting the system using these lights.

S1, S2 - These two red lights indicate the position of the power feed drum switch. Three possible positions are shown in table below. If the lights are not on or off as shown, the power feed drum switch is probably miswired or defective.

See Table 6-2. The light states and drum switch positions are shown below.

Power Feed Drum Switch Position	S1	S2
FORWARD	On	Off
REVERSE	Off	On
NEUTRAL	On	On

TABLE 6-2

OUT1 - This red light is on when power is applied to the accessory solenoid. When the OUT1 is off, the accessory solenoid is not powered. Check the jumper cable connecting Vkey1 and Vkey2 Terminals. Reconnect if necessary. If the light is still off the accessory solenoid may be defective.

Vcc - The Vcc light is on when power is applied to the Vkey2 Terminal. If the light is off, check all connections to the key switch. Also check the fuse located between the Vkey2 terminal and the key switch.

Vcc2 - This red light indicates that power is applied at the control circuits from the key switch. The light is off when the Vcc light is off. Refer to the Vcc light problems when troubleshooting this light.

Vcc3 - This red light is on indicating the power feed control circuits. The light is off when the Vcc and Vcc2 are off. Refer to the Vcc light to solve potential problems.

6 Troubleshooting Guide

Power Feed Circuit Troubleshooting

The LED Bar Graph located on the power feed board can also be used to troubleshoot feed problems. Check below for different codes on the LED Bar Graph to find the problem.

See Figure 6-2. The operational codes of the LED Bar Graph are shown below.

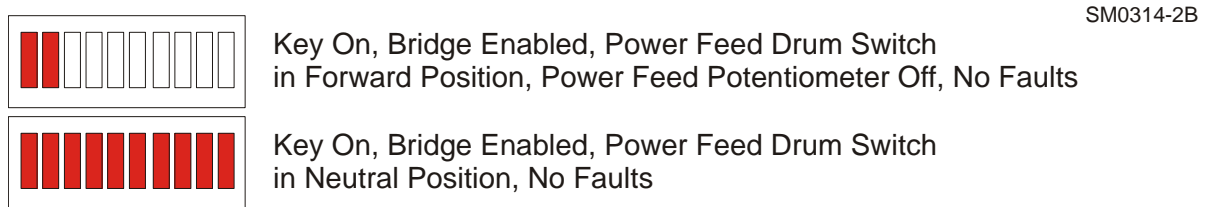

FIG. 6-2

See Figure 6-3. The LED Bar Graph problem codes are shown below.

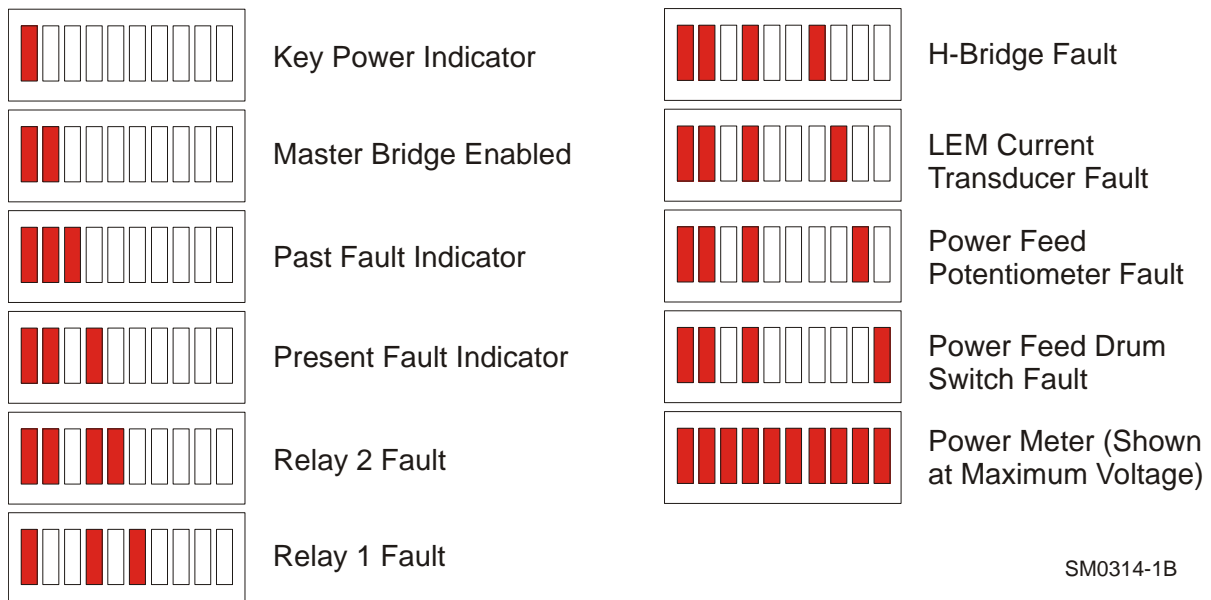

FIG. 6-3

When troubleshooting the system, please note which LED Bar Graph lights are on and contact Customer Service for assistance.

LT30HD Super
LT40HD Super

Rev. J7.01 - J7.03
Rev. J7.01 - J7.03

LED lights are provided on the control module to help troubleshoot any feed problems you may encounter.

See Figure 6-4. The lights can be viewed by removing the rear control box panel.

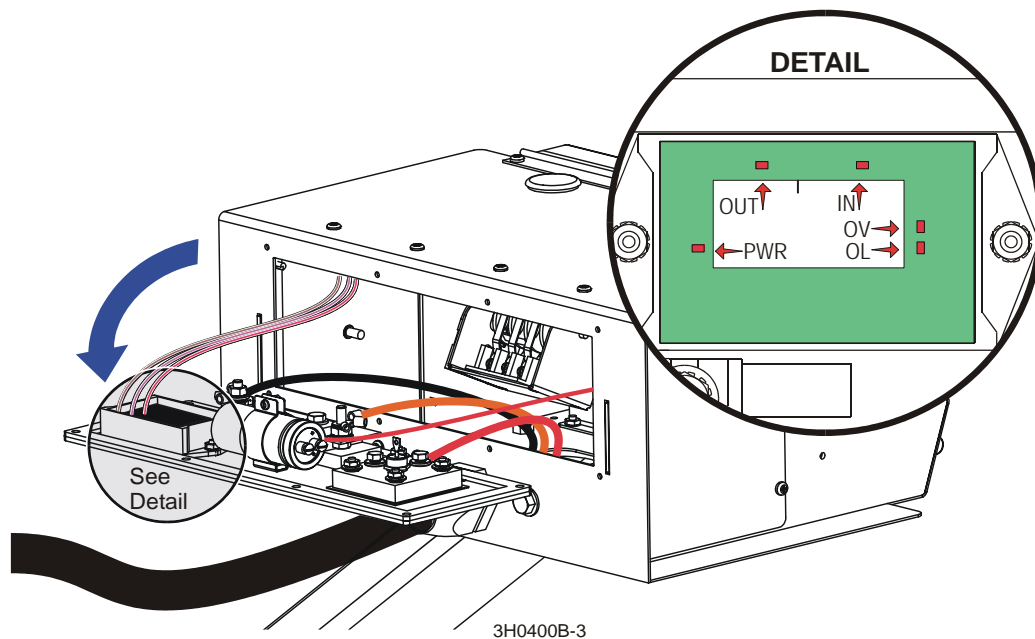

FIG. 6-4

If you have trouble determining the problem indicated by the LED lights, please note which lights are on and call customer service for assistance.

IN - This light normally brightens and dims as the feed rate switch is turned up or down. If the light is always on or always off, the feed rate switch is probably miswired. An erratic light indicates a worn or defective feed rate switch.

OV - This light indicates an overvoltage condition. This can be caused by a defective alternator not regulating voltage properly or a bad connection. The OV light will come on and deactivate the power feed control output until the problem is corrected.

OL - This light indicates an extreme overload condition of the power feed motor caused by a mechanical bind or a short in the wiring between the motor and circuit board. The OL light will come on and deactivate the power feed control output until the problem is corrected.

OUT - This light normally dims and brightens at the same rate as the IN light when the feed rate switch is turned up and down. If the OUT light does not correspond with the IN

6

Troubleshooting Guide

Power Feed Circuit Troubleshooting

light, look to see if OV or OL lights are coming on. If not, then the control module may be damaged. Call Customer Service for assistance.

PWR - Indicates battery power is present at the power feed control circuit board.

6.5 Hydraulic Problems



WARNING! Disconnect and lockout power before performing any service to the electrical system. For battery-powered equipment, disconnect the negative battery terminal cable. Failure to do so may result in injury and/or electrical system damage.



WARNING! Before performing service near moving parts such as blades, pulleys, motors, belts and chains, first turn the key switch to the OFF (#0) position and remove the key. If the key is turned on and moving parts activated, serious injury may result.

PROBLEM	CAUSE	SOLUTION
You Can Actuate Any Hydraulic Handle, But Get No Response From The Pump.	Carriage not positioned properly to provide power to the pump	Make sure carriage contact bracket is adjusted far enough forward for battery positive contact to touch 6ft. strip on main tube. Check contact and strip for tarnish or loose wires. Clean as necessary
	Poor ground connection	Check ground connection between pump and saw frame and between battery negative contact and lower rail. Check contact and rail for tarnish or loose wires. Clean as necessary
	Blown fuse	Replace
	Low or dead battery	Test battery amperage capability (such as low battery charge, low alternator output, defective voltage regulator, bad battery cell, battery age deterioration, etc.). Replace or recharge as necessary
	Poor cable connection	Check cable connection and make sure that battery terminals are in good condition (not corroded)
You Can Actuate Any Hydraulic Handle, But Get No Response From The Pump.	Defective solenoid (may be indicated by solenoid clicking) See Monarch manual for troubleshooting solenoid	After checking all other possibilities for low voltage to solenoid, check solenoid. Tapping on solenoid may fix temporarily. Replace solenoid if necessary. NOTE: The solenoid is not a standard automotive type. Order from Wood-Mizer only
	Defective pump motor	Remove motor from pump and inspect. Repair or replace as necessary

6

Troubleshooting Guide

Hydraulic Problems

PROBLEM	CAUSE	SOLUTION
You Can Get Response From the Pump By Actuating All But One or Two Handles	Valve assembly switch contacts are not properly adjusted	Locate the valve switch at the bottom of the valve assembly. Use a 3MM allen wrench to loosen the set screw on each of the five switch contacts. Press each contact to the valve block and tighten the contact set screw to secure in place. CAUTION! Do not overtighten! NOTE: Do not adjust the valve switch or switch spring; they have been preset at the factory.
Pump Motor Runs With Little Or No Response From The Cylinders	Low battery	Test battery. Recharge or replace as necessary
	Low fluid level	Check fluid level. Add an all-season hydraulic fluid such as Amoco Rycon Oil MV or Mobil Multipurpose ATF (automatic transmission fluid) until level is 4 - 4 1/2" from bottom of reservoir with all cylinders retracted
	Pressure relief valve moved from proper setting	Adjust pressure relief valve.
Pump Motor Runs Continuously When Power Contact Is Made	Low air temperature causing fluid to thicken	Allow fluid to warm up. Synthetic fluids are available that allow for hydraulic operation in cold weather conditions (Univis HVI 13)
	Solenoid is stuck closed	Tapping the solenoid may solve this problem temporarily. Replace solenoid
Fluid Leaks From Around Cylinder Piston Ram	Worn seals	Replace seals in cylinder. Check piston ram for abrasive weld that may be causing premature seal failure
Fluid Leak Around Pump Box	Loose seal or fitting	Wipe pump off completely to locate cause of leak. You may have to unbolt the pump to wipe behind it. NOTE: Movement of the sawmill can cause fluid to slosh up into the foam filter in the reservoir cap, and subsequently spray out, giving the appearance that fluid is leaking from the pump

PROBLEM	CAUSE	SOLUTION
Hydraulic Side Supports Go Down Before Or At Same Time As Log Turner	Dirt in sequence valve	Remove sequence valves and clean thoroughly with kerosene. NOTE: Be sure to reassemble the valve and install it in its original position on the cylinder
	Retainer in sequence valve worn	Replace sequence valve
	Low air temperature causing fluid to thicken	Allow fluid to warm up. Synthetic fluids are available that allow for hydraulic operation in cold weather conditions (Univis HVI 13)
Hydraulic Turner Goes Up Before Or At Same Time As Side Supports	Dirt in sequence valve	Remove sequence valves and clean thoroughly with kerosene. NOTE: Be sure to reassemble the valve and install it in its original position on the cylinder
	Retainer in sequence valve worn	Replace sequence valve
	Low air temperature causing fluid to thicken	Allow fluid to warm up. Synthetic fluids are available that allow for hydraulic operation in cold weather conditions. (Univis HVI 13)

6 Troubleshooting Guide

Hydraulic Problems

PROBLEM	CAUSE	SOLUTION
<p>Hydraulic Toe Boards "Creep" UP without the valve control handles being operated.</p>	<p>Can be a result of shock load caused by improperly using the toe boards to "cushion" or break the fall of a cant onto the bed):</p> <ul style="list-style-type: none"> · damaged hoses · damaged cylinder seals or cylinder · damaged valve 	<p>INITIAL CHECK</p> <p>To check, disconnect the toe board hydraulic hose from its current valve section and temporarily connect it to another valve section. Check to see if the hydraulics operate properly.</p> <p>If hydraulics operate properly, hoses and cylinder seals are good. Perform further valve inspection, found below.</p> <p>If up creep still occurs, check all hoses for possible pinholes causing leakage. Replace if applicable. Retest. If up creep still occurs, replace cylinder seals or cylinder and retest.</p> <p>Be sure to reconnect the hose to the proper valve section when done.</p> <p>FURTHER VALVE INSPECTION</p> <p>If further inspection of the valve is required after initial check, remove the check valve shown below. Flush the check valve with an air hose or solvent to remove any dirt from the valve's seat. Reinstall and test again. Check to see if the hydraulics operate properly.</p> <p>If up creep still occurs, replace the check valve with a new one. Retest. If up creep still occurs, replace the hydraulic valve.</p>

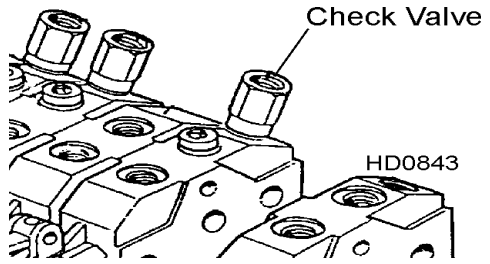

PROBLEM	CAUSE	SOLUTION
<p>Hydraulic Toe Boards or Clamp "Creep" DOWN without the valve control handles being operated OR do not raise or lower at all.</p>	<p>Can be a result of shock load caused by improperly using the toe boards or clamp to "cushion" or break the fall of a cant onto the bed):</p> <ul style="list-style-type: none"> · damaged hoses · damaged cylinder seals or cylinder · damaged valve 	<p><u>INITIAL CHECK</u></p> <p>To check, disconnect the toe board hydraulic hose from its current valve section and temporarily connect it to another valve section. Check to see if the hydraulics operate properly.</p> <p>If hydraulics operate properly, hoses and cylinder seals are good. Perform further valve inspection, found below.</p> <p>If down creep still occurs, check all hoses for possible pinholes causing leakage. Replace if applicable. Retest. If down creep still occurs, replace cylinder seals or cylinder and retest.</p> <p>Be sure to reconnect the hose to the proper valve section when done.</p> <p><u>FURTHER VALVE INSPECTION</u></p> <p>If further inspection of the valve is required after initial check, remove the check valve shown below. Flush the check valve with an air hose or solvent to remove any dirt from the valve's seat. Reinstall and test again. Check to see if the hydraulics operate properly.</p> <p>If down creep still occurs, replace the check valve with a new one. Retest. If down creep still occurs, replace the hydraulic valve.</p>

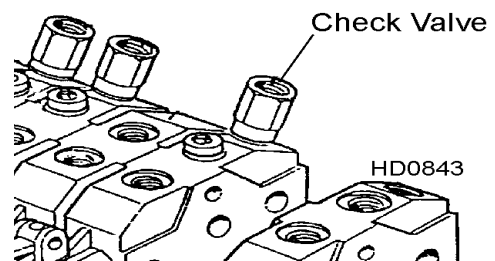

<p>Bad check valve (results in one of the toe boards experiencing down-creep)</p>	<p>Check the release valve as instructed above. If the release valve is good, replace the high-pressure hydraulic check valves (A12869) located on the pump.</p>
---	--

6 Troubleshooting Guide

Hydraulic Problems

PROBLEM	CAUSE	SOLUTION
Pump runs but makes “growling” sound and hydraulic functions are slow, jerky or don’t work at all.	Low fluid level	Check fluid level and add fluid as necessary. Check for leaks in the system at the control box fittings, hoses and cylinders
One of the log loader cylinders does not move when lowering the loader causing the foot of other to raise completely before loader will start down.	Damaged cylinder shaft	Replace the cylinder that is not moving

6.6 Engine/Motor and Drive Pulleys Alignment



WARNING! Before performing service near moving parts such as blades, pulleys, motors, belts and chains, first turn the key switch to the OFF (#0) position and remove the key. If the key is turned on and moving parts activated, serious injury may result.



WARNING! Do not for any reason adjust the engine drive belts or belt support bracket with the engine running. Doing so may result in serious injury.

1. Install and properly tension the drive belt ([See Section 5.8](#)).
2. With the clutch handle disengaged, use a straight edge to check the alignment of the pulley on the engine/motor to the alternator pulley. Loosen the bushing on the engine/motor pulley and adjust if necessary until it is aligned with the alternator pulley.
3. With the clutch handle disengaged, use a straight edge to check the alignment of the engine/motor pulley to the main drive pulley. Loosen the bushing on the drive pulley and adjust if necessary until it is aligned with the engine/motor pulley.
4. **(E25 Only):** Check that the engine/motor pulley is also square with the drive pulley. If necessary, loosen the engine mounting bolts and cock the engine until the pulley is square with the drive pulley. Retighten the engine mounting bolts.
5. Check that all engine mounting bolts and pivot bushing clamps are tight.
6. Engage the clutch handle and recheck the pulley alignment. Adjust if necessary.
7. If any pulleys were adjusted, recheck the drive belt support(s) and adjust if necessary ([See Section 5.8](#)).

6.7 Power Feed Variable Feed Rate Switch Test

With the feed rate dial switch all the way down, move the shaft of the dial back and forth to see if there is a jerky response. Turn the dial and move the shaft back and forth again. Repeat several times. If the jerkiness occurs at the same location on the dial several times, you need to replace the variable speed switch.



WARNING! Disconnect and lockout power before performing any service to the electrical system. For battery-powered equipment, disconnect the negative battery terminal cable. Failure to do so may result in injury and/or electrical system damage.

6.8 Power Feed Preliminary Test

This test will determine if the problem is mechanical or electrical.

1. Remove the drive belt from the power feed drive pulley.
2. Turn the key switch to the ACC position. Put the carriage forward/reverse switch into the forward position and turn the feed rate dial through all speeds. If the power feed motor runs properly at all speeds, the problem is a mechanical one instead of an electrical one.

6.9 Power Feed Mechanical Test

1. Remove the weight from the track rollers. They should turn smoothly and easily with very little play.
2. Make sure the middle track cover is not bent or touching the top rail.
3. Make sure the middle track oiler is free of sawdust buildup.
4. Make sure the power feed chain is not stiff from rust. Also make sure the chain is not too tight.
5. Check the power feed shaft. Visually inspect the bearings. The shaft should move neither in or out nor side to side.
6. Make sure the power feed chain cam bearing is not touching the main frame tube.
7. Make sure there is no sap or rust on the rails.
8. Make sure the stop on the lower track roller assembly is not rubbing the lower rail. Also make sure the track rollers are not too tight.
9. Make sure the power feed belt is properly tightened.

6.10 Hydraulic Pressure Test

To check hydraulic pressure:

See Figure 6-5.

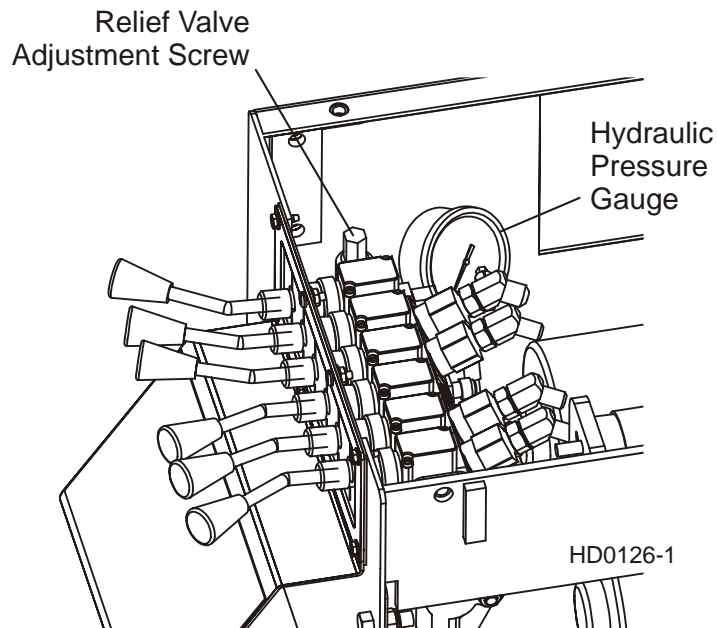

FIG. 6-5

Operate the loading arm hydraulic lever and read the pressure on the gauge. Hydraulic pressure is factory-set at 2200 psi and should not need to be readjusted. The relief valve adjustment screw shown may be used to fine-tune the hydraulic pressure:

Remove the adjustment screw nut. Tighten the adjustment screw (clockwise) to increase pressure. Loosen the adjustment screw (counterclockwise) to lower pressure.



CAUTION! Pressure should not exceed 2200 psi. If it does, the amp draw will rise above the design maximum of 200 amps, and could cause battery and system problems. Pressure above 2200 psi may also damage the hydraulic hoses.

6.11 Fuse Terminal Extension Stud

LT30HD Super
LT40HD Super

Rev. J7.01 - J8.09
Rev. J7.01 - K2.00

A fuse terminal extension stud is provided in the fuse box. The extension may be used to temporarily connect a battery charger or jumper cables to raise the saw head from the towing position so the battery box lid can be removed.



CAUTION! The fuse stud extension is designed to provide enough power to raise the saw head only. Do not attempt to start the engine or operate any other electrical function until direct battery charging can be performed. Do not attempt to move the saw head by attaching jumper cables from a secondary power source to the up/down motor terminals. Damage to the electrical system will result.

See Figure 6-6.

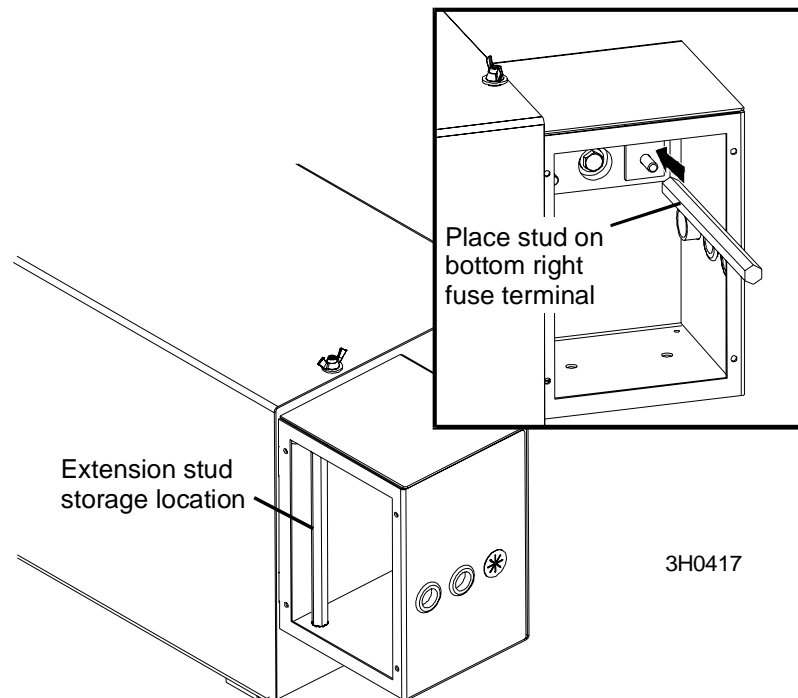

FIG. 6-6

1. Remove the fuse box cover and remove the stud from its storage position inside the fuse box.
2. Thread the extension stud on the bottom-right fuse terminal.

3. Attach the positive cable from a battery charger or jumper cables to the extension stud.
4. Connect the negative cable from the charger or jumper cables to a grounded metal surface. The mounting bolts on the bottom of the control box are an acceptable ground.
5. Charge or jump the battery until it can supply enough power to raise the saw head.
6. After the saw head is raised, remove the negative cable from ground.
7. Remove the positive cable from the extension stud.
8. Remove the extension stud from the fuse terminal and return it to its storage location.
9. Remove the battery box lid and connect the positive cable directly to the positive battery terminal.
10. Connect the negative cable to a grounded metal surface.
11. After the battery is completely recharged, remove the negative charger cable from ground. Remove the positive cable from the battery and replace the battery box lid.

6.12 Circuit Breaker Operation

Sawmill controls are equipped with manual reset circuit breakers to protect the electrical circuits.

See Figure 6-7. The power feed and up/down breakers are externally mounted at the front of the control box. The blade guide, accessory, ignition, start and board return breakers are located inside the control box. Remove the circuit breaker panel from the control box to access the internal breakers.

NOTE: If the breaker is still hot, you may not be able to reset it immediately. Allow the breaker to cool for a few minutes before attempting to reset.

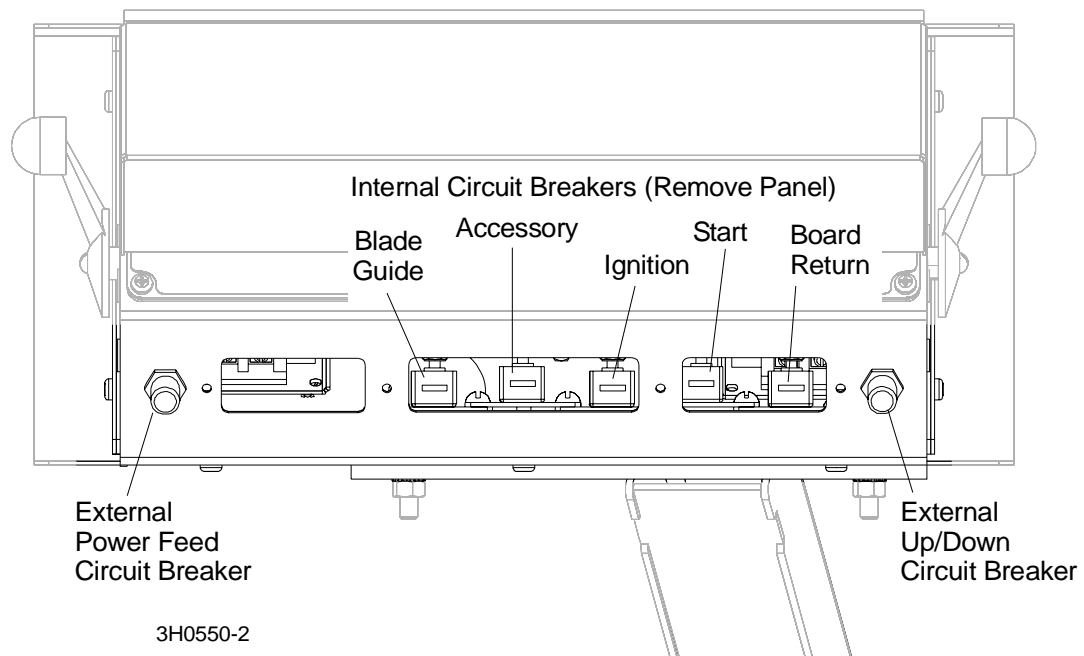

FIG. 6-7

SECTION 7 SAWMILL ALIGNMENT

The Wood-Mizer sawmill is factory aligned. Two alignment procedures are available to realign the sawmill if necessary. The Routine Alignment instructions should be performed as necessary to solve sawing problems not related to blade performance. The Complete Alignment procedure should be performed approximately every 1500 hours of operation (sooner if you regularly transport the sawmill over rough terrain).

7.1 Routine Alignment Procedure

Blade Installation

1. Remove the blade and check the blade wheel belts. Remove any sawdust buildup from the surface of the belts. Replace worn belts if they do not keep the blade from contacting the blade wheel.
2. Install a clean blade and apply the appropriate tension ([See Section 3.4](#)).
3. Inspect the blade guide blocks for damage or wear and replace as necessary. Check the blade guide blocks and drive side deflector plate are properly adjusted ([See Section 5.2](#)).
4. Adjust the idle-side cant control to track the blade ([See Section 3.5](#)).
5. Close the middle blade housing cover and make sure all persons are clear of the open side of the saw head.
6. Start the engine (or motor).
7. Engage the blade, rotating the blade until the blade positions itself on the wheels.



WARNING! Do not spin the blade wheels by hand. Spinning the blade wheels by hand may result in serious injury.

8. Disengage the blade. Turn the engine off and remove the key.

Saw Head Tilt

As the blade enters a wide log or cant, the outside of the saw head will drop down slightly. To compensate for the drop, the saw head is adjusted $1/16$ " (1.5 mm) higher at the outside.

1. Move the saw carriage so the blade is positioned over a bed rail. Adjust the blade guide arm to $1/2$ " (15 mm) from full open.
2. Raise the saw head so the bottom of the blade measures $14\ 3/4$ " (375 mm) from the top surface of the bed rail near the inner blade guide assembly.

See Figure 7-1.

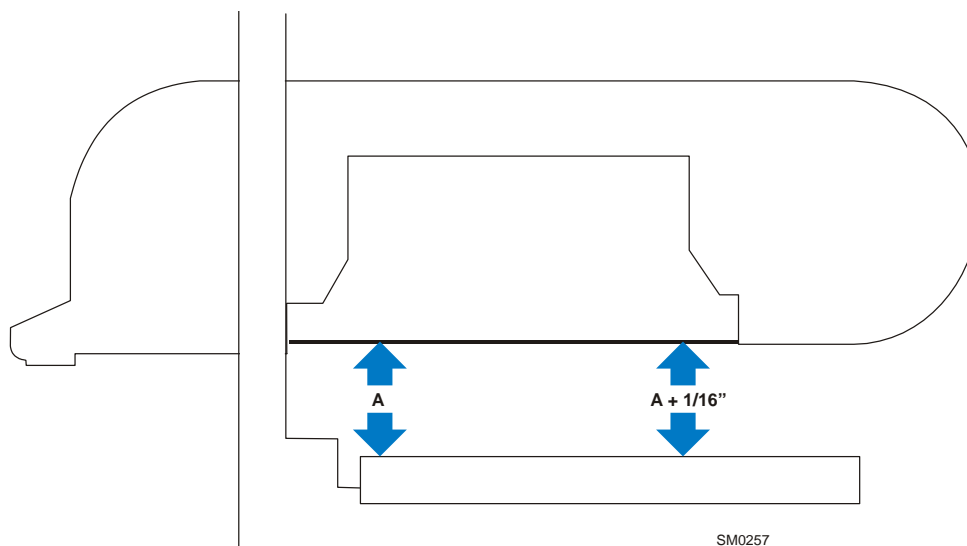
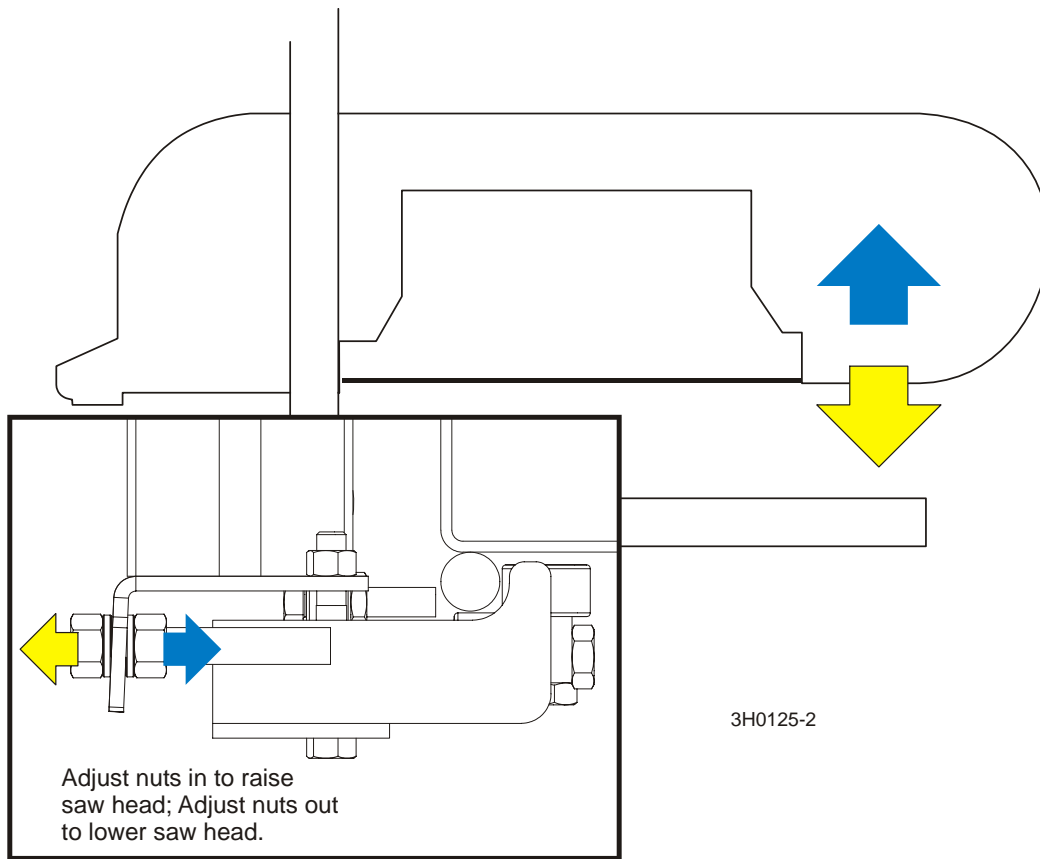

FIG 7-1

3. Measure from the blade to the bed rail near the outer blade guide assembly. This measurement should be $1/16$ " (1.5 mm) higher than the inner measurement or $14\ 13/16$ " (376.5 mm).

See Figure 7-2. To adjust the saw head tilt, use the horizontal adjustment nuts. To raise the outside of the saw head, loosen the four inner adjustment nuts 1/4 turn and tighten the four outer nuts. Recheck the measurement from the blade to the bed rails and adjust the horizontal adjustment nuts until the outside of the saw head is 1/16" higher than the inside.



DETAIL OF LOWER TRACK ROLLER ASSEMBLY

FIG. 7-2

7 Sawmill Alignment

Routine Alignment Procedure

Blade Guide Arm Alignment

The blade guide arm moves the outer blade guide in and out. If the arm becomes loose, the blade guide will not deflect the blade properly, causing inaccurate cuts. A loose blade guide arm can also cause blade vibration.

1. Adjust the blade guide arm in to 1/2" (15 mm) from fully closed.
2. Manually try to move the arm up and down. If you can move the arm by hand, you will need to tighten the arm rollers.

See Figure 7-3. Remove the blade housing cover to access the blade guide arm roller mounting bolts. The blade guide arm rollers are mounted on cam-shaped bolts. Turning the bolts will cause each roller to move up or down. If the inner lower roller is loose, adjust the inner top roller down. If the outer lower roller is loose, adjust the outer lower roller up. Retighten the jam nuts and recheck the tightness of the bottom rollers.

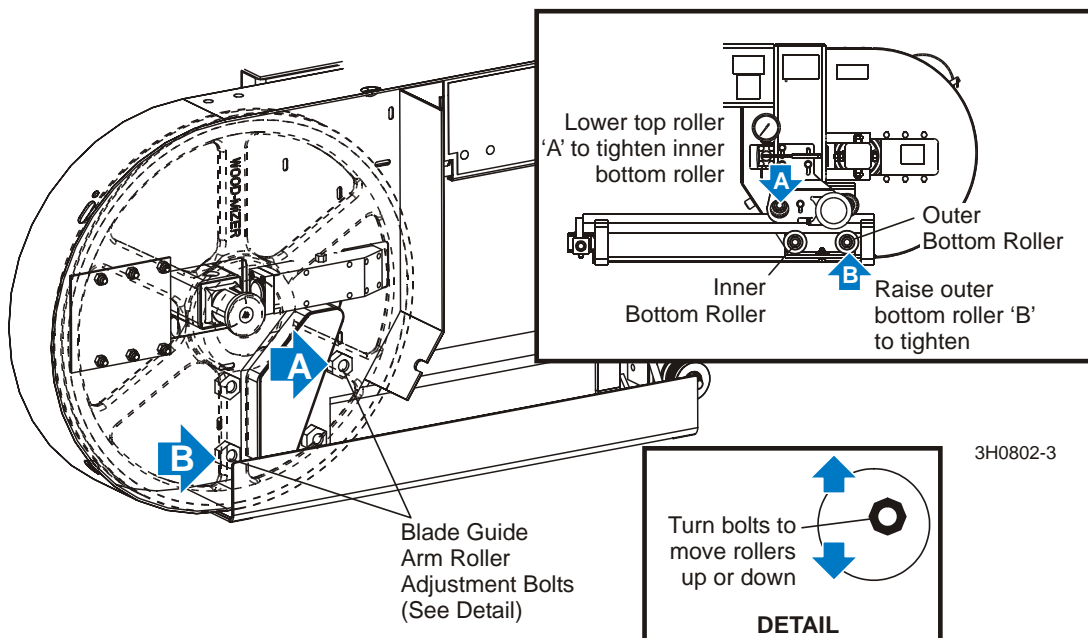

FIG. 7-3

After tightening the blade guide arm rollers, check that the arm is aligned properly.

3. With the arm adjusted 1/2" (15 mm) from fully closed, measure the distance between the blade guide roller flange and the back of the blade.

See Figure 7-4.

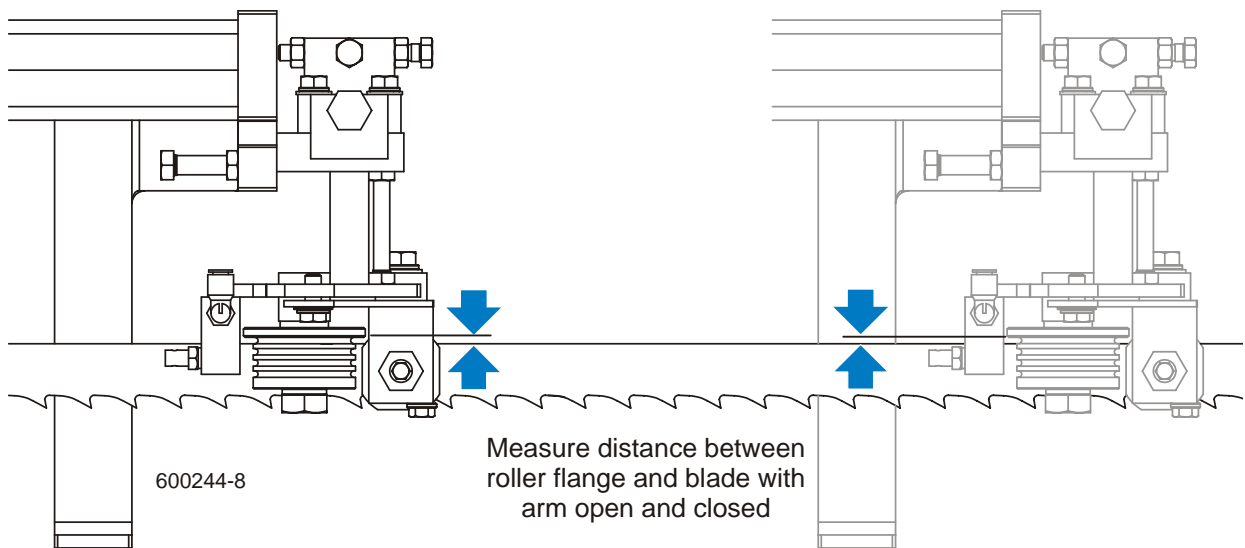

FIG. 7-4 REV. K1.01 - K3.02 (OPTIONAL HIGH-PERFORMANCE ROLLER/BLOCKS SHOWN)

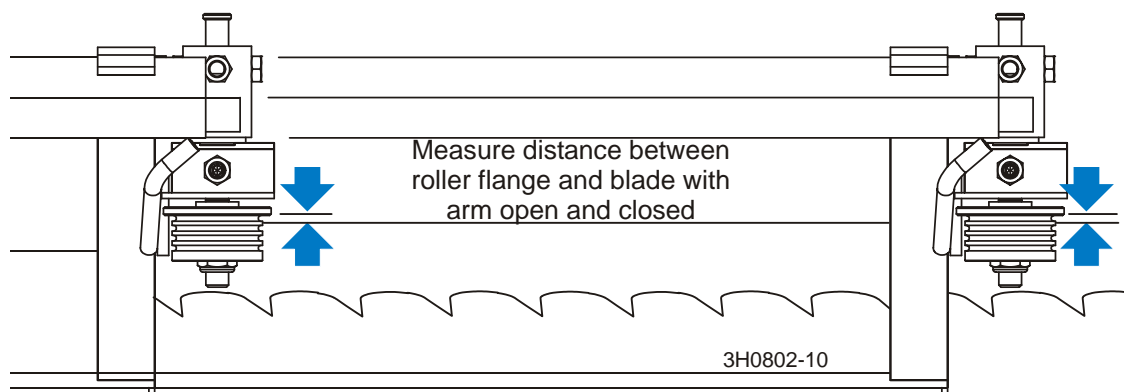

FIG. 7-4 PRIOR TO REV. K1.01

4. Adjust the blade guide arm to 1/2" (15 mm) from fully open and remeasure the distance from the roller flange to the back of the blade. The two measurements should be the same. If not, adjust the outer rollers in or out to tilt the arm horizontally.

7

Sawmill Alignment

Routine Alignment Procedure

See Figure 7-5. To tilt the arm in toward the blade, loosen the front nuts on the outer rollers and tighten the rear nuts. To tilt the arm out away from the blade, loosen the rear nuts on the outer rollers and tighten the front nuts. Recheck the blade guide arm horizontal tilt.

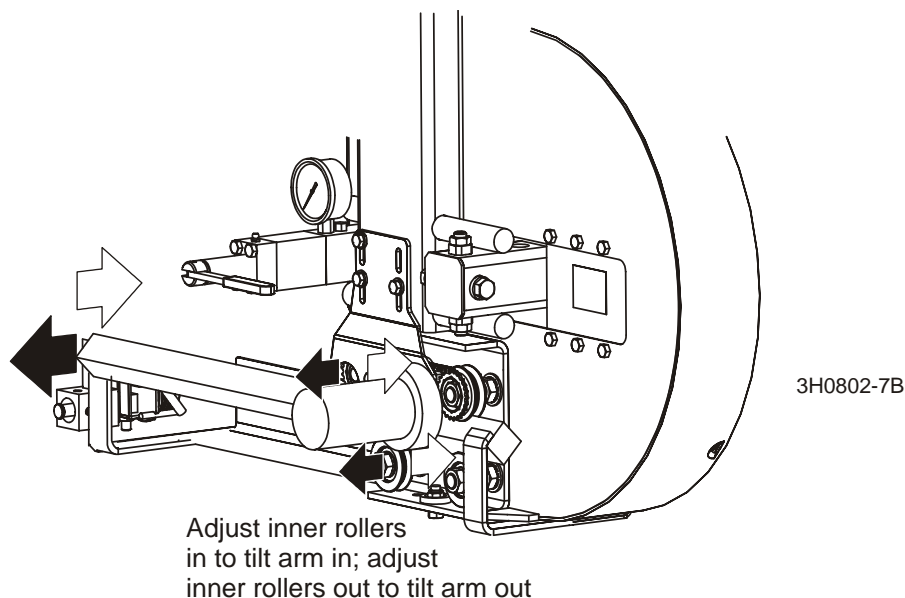

FIG. 7-5

5. Now check the vertical tilt of the blade guide arm. Move the saw carriage so the blade guide arm is positioned over a bed rail.
6. With the arm 1/2" (15 mm) from fully closed, raise or lower the saw head until the bottom of the blade guide block is 15" (375 mm) from the top of the bed rail.

See Figure 7-6.

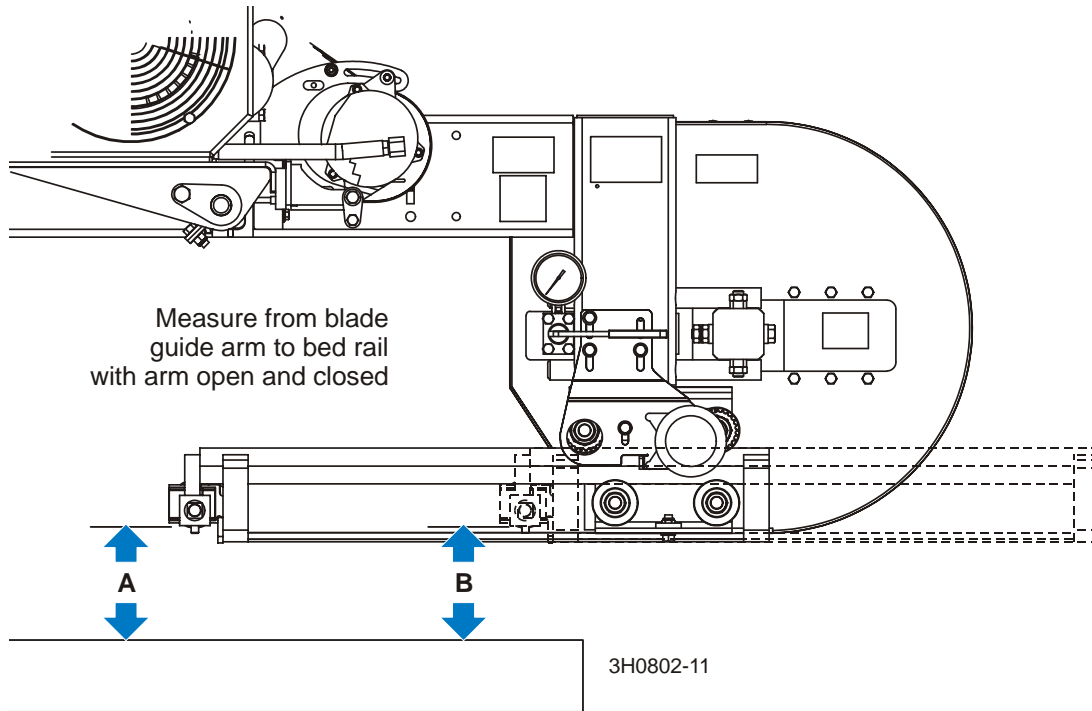

FIG. 7-6

7. Adjust the blade guide arm to 1/2" (15 mm) from fully open. Measure the distance from the bottom of the blade guide mounting block to the bed rail. This measurement should be 15" (376.5 mm) or slightly higher because the saw head is tilted up 1/16" (1.5 mm) on the outside ([See Saw Head Tilt](#)). If the blade guide is closer to the bed rail or more than 1/16" higher with the arm open, adjust the outer rollers up or down to tilt the blade guide arm vertically.

7 Sawmill Alignment

Routine Alignment Procedure

See Figure 7-7. Remove the blade housing cover to access the blade guide arm roller mounting bolts. To adjust the rollers, loosen the jam nuts on the other side of the blade housing and turn the mounting bolts. To tilt the blade guide arm down, adjust the outer top and bottom rollers up. To tilt the blade guide arm up, adjust the outer top and bottom rollers down. Retighten the jam nuts and recheck the blade guide arm vertical tilt.

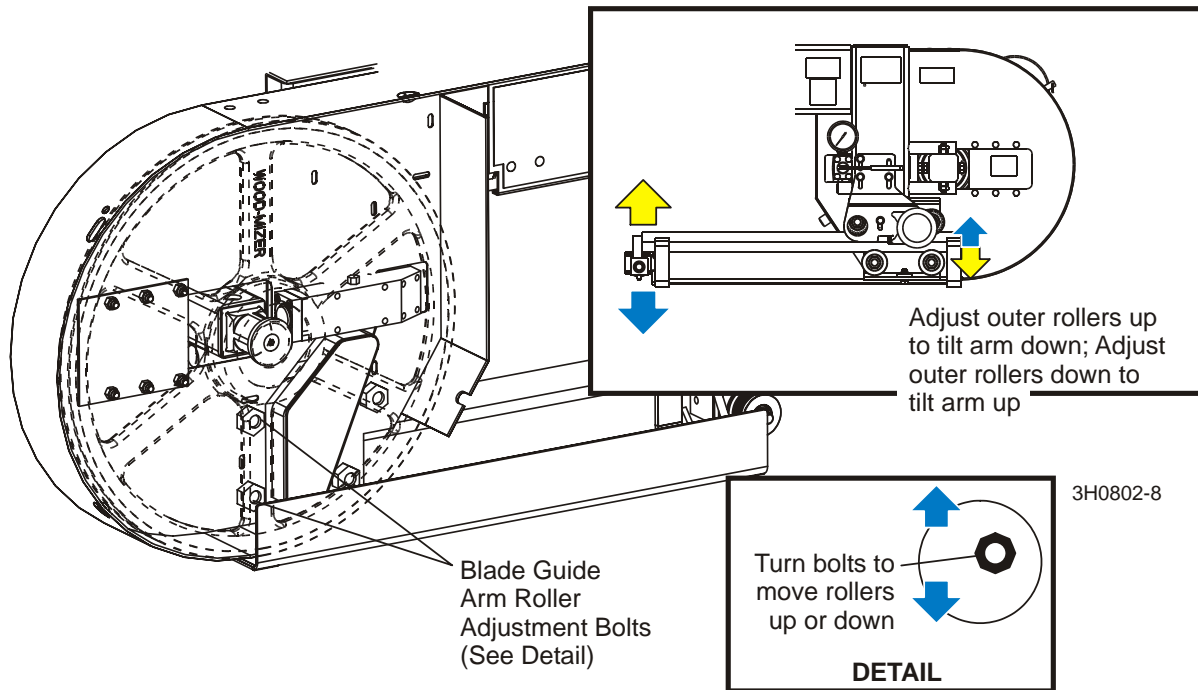

FIG. 7-7

Blade Guide Vertical Tilt Alignment

The blade guides should be adjusted properly in the vertical plane. If the blade guides are tilted vertically, the blade will try to travel in the tilted direction.

A Blade Guide Alignment Tool (BGAT) is provided to help you measure the vertical tilt of the blade.

1. Open the adjustable blade guide arm 1/2" (15 mm) from full open.
2. Clip the alignment tool on the blade. Position the tool close to the outer blade guide assembly. Be sure the tool does not rest on a tooth or burr, and is lying flat against the bottom of the blade.

See Figure 7-8.

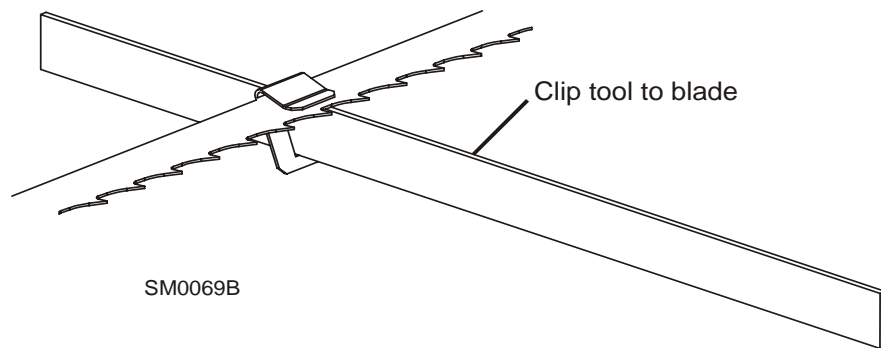

FIG. 7-8

3. Move the carriage so that the front end of the tool is positioned above the bed rail. Measure the distance from the bed rail to the bottom edge of the tool.
4. Move the carriage so that the back end of the tool is positioned above the bed rail. Measure the distance from the bed rail to the bottom edge of the tool.
5. If the measurement from the tool to the bed rail is not equal within 1/32" (.75 mm), adjust the vertical tilt of the outer blade guide roller.
6. Loosen one set screw at the side of the blade guide assembly.

7 Sawmill Alignment

Routine Alignment Procedure

See Figure 7-9. Loosen the jam nuts on the top and bottom vertical tilt adjustment screws. To tilt the roller up, loosen the bottom screw and tighten top screw. To tilt the roller down, loosen the top screw and tighten the bottom screw. Tighten the jam nuts and recheck the tilt of the blade.

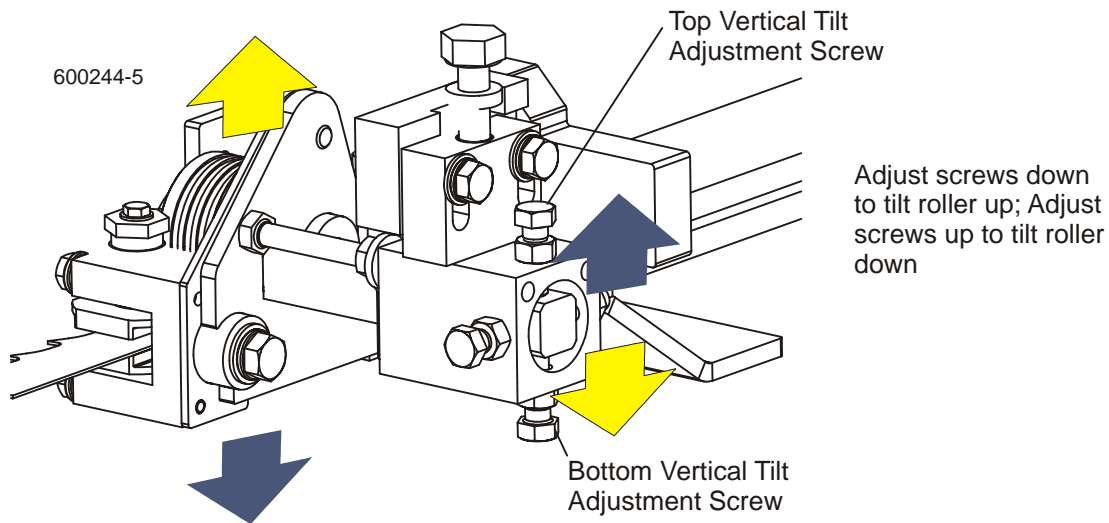

FIG. 7-9 REV. K1.01 - K3.02 (OPTIONAL HIGH-PERFORMANCE ROLLER/BLOCKS SHOWN)

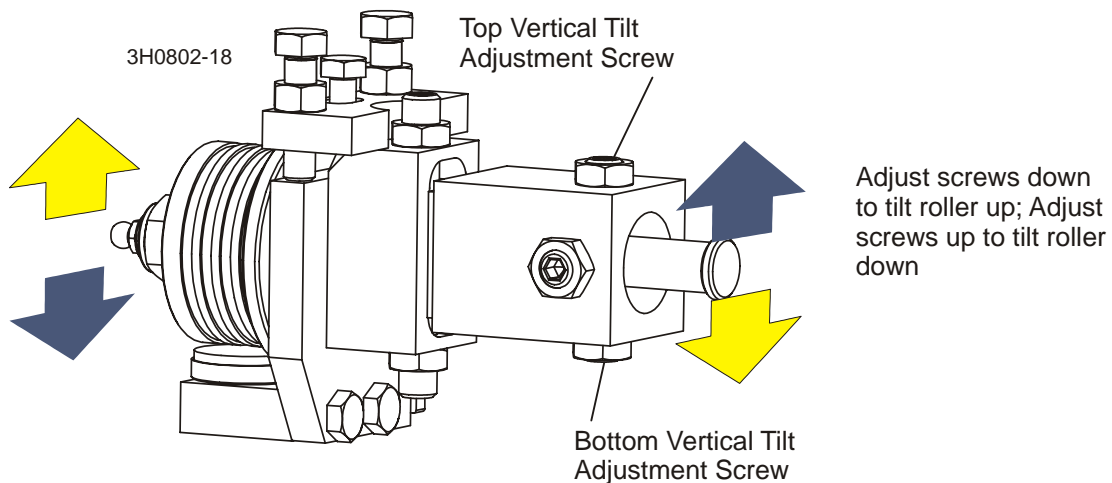

FIG. 7-9 PRIOR TO REV. K1.01

7. Move the blade guide alignment tool close to the inner blade guide roller assembly and repeat the above steps. Adjust the vertical tilt of the inner blade guide if necessary.

Blade Guide Horizontal Tilt Adjustment

If the blade guides are tilted in the wrong direction horizontally, the back of the blade may contact the flange as the roller is spinning down, causing it to push the blade away from the guide roller.

8. Remove the blade guide alignment tool from the blade and adjust the blade guide arm halfway in.
9. Remove the clip from the blade guide alignment tool. Place the tool against the face of the outer blade guide roller.

See Figure 7-10.

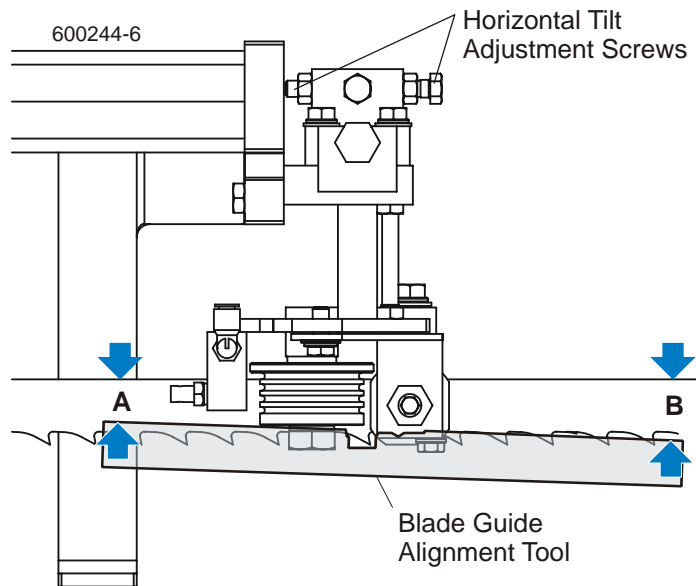

FIG. 7-10 REV. K1.01 - K3.02 (OPTIONAL HIGH-PERFORMANCE ROLLER/BLOCKS SHOWN)

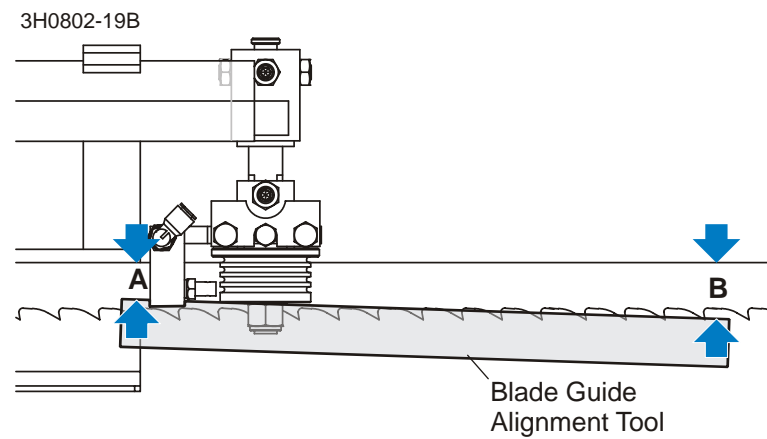

FIG. 7-10 PRIOR TO REV. K1.01

10. Measure between the back edge of the blade and the tool at the end closest to the inner blade guide ("B").
11. Measure between the back edge of the blade and the other end of the tool ("A").

The roller should be tilted slightly to the left ('A' 1/8" [3 mm] less than 'B' \pm 1/8" [3 mm]).

See Figure 7-11. Loosen the jam nuts on the horizontal tilt adjustment screws. To tilt the roller left, loosen the right screw and tighten left screw. To tilt the roller right, loosen the left screw and tighten the right screw. Tighten the jam nuts and recheck the tilt of the blade.

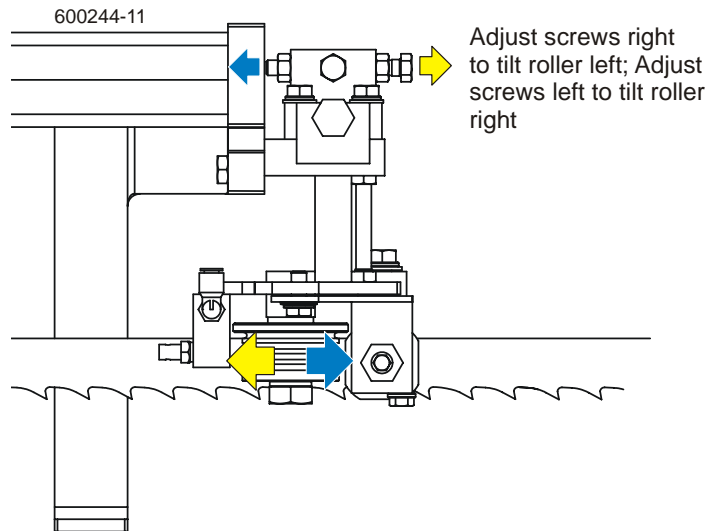

FIG. 7-11 REV. K1.01 - K3.02 (OPTIONAL HIGH-PERFORMANCE ROLLER/BLOCKS SHOWN)

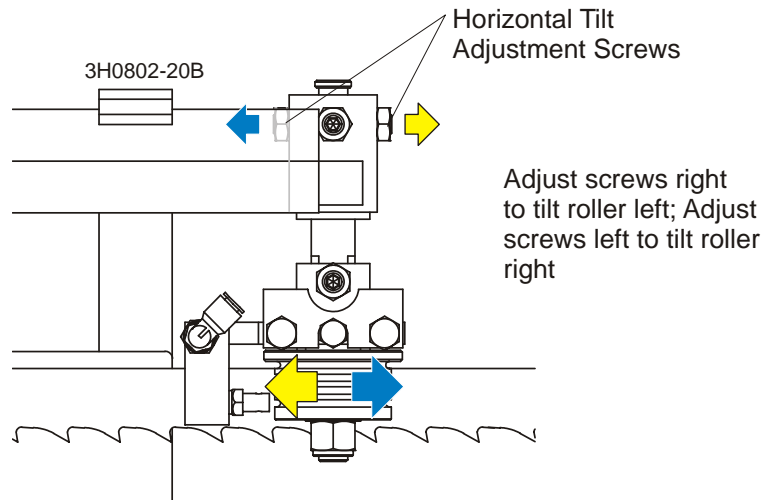

FIG. 7-11 PRIOR TO REV. K1.01

12. Repeat the above steps for the inner blade guide roller assembly.

NOTE: Once the blade guides have been adjusted, any cutting variances are most likely caused by the blade. [See Blade Handbook, Form #600.](#)

Blade Guide Flange Spacing

Each blade guide must be adjusted so the roller flange is the correct distance from the back edge of the blade. If the flange is too close to or too far from the blade, the sawmill will not cut accurately.

HINT: When adjusting blade guide spacing, loosen the top set screw and one side set screw only. This will ensure horizontal and vertical tilt adjustments are maintained when the adjustment screws are retightened.

1. Measure the distance between the flange on the outer blade guide roller to the back edge of the blade. This distance should measure 1/8" (3.0 mm). Adjust the roller back or forward if necessary.

See Figure 7-12. Loosen the top and one side screw shown. Tap the blade guide forward or backward until properly positioned. Retighten the screws and jam nuts.

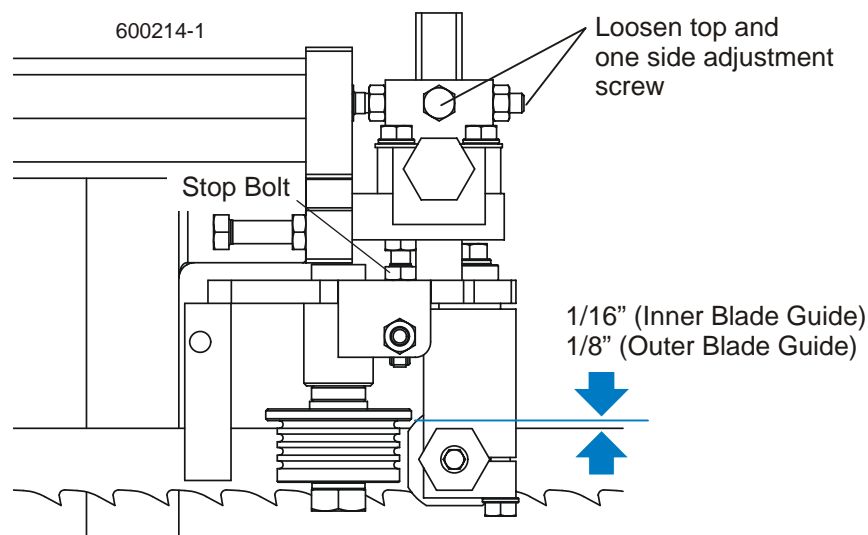

FIG. 7-12REV. K1.01 - K3.02 (OPTIONAL HIGH-PERFORMANCE ROLLER/BLOCKS SHOWN)

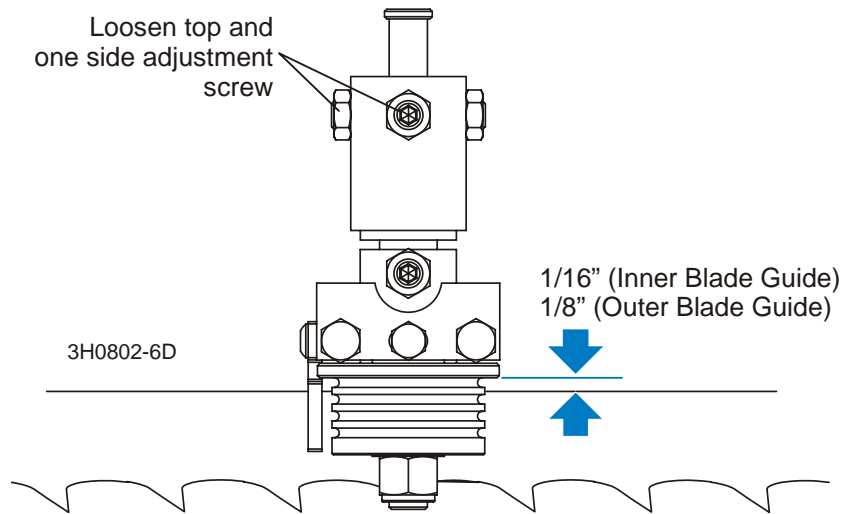

FIG. 7-12 PRIOR TO REV. K1.01

2. Measure the distance between the flange on the inner blade guide roller to the back edge of the blade. This distance should measure 1/16" (1.5 mm). Adjust the roller back or forward if necessary.

Side Support Alignment

Logs and boards are clamped against the side supports when sawing. The side supports must be square to the bed to ensure square lumber.

1. Swing a side support down and measure between the face of the support and the main bed tube. The distance at the top of the side support ('B') should be equal to or no more than 1/32" (0.8 mm) greater than the distance at the base of the side support ('A'). Adjust the horizontal tilt of the side support if necessary.

See Figure 7-13. Loosen the two adjustment plate mounting bolts. Use a mallet to move the plate until the side support is parallel to the bed tube in the horizontal position. Retighten the mounting bolts.

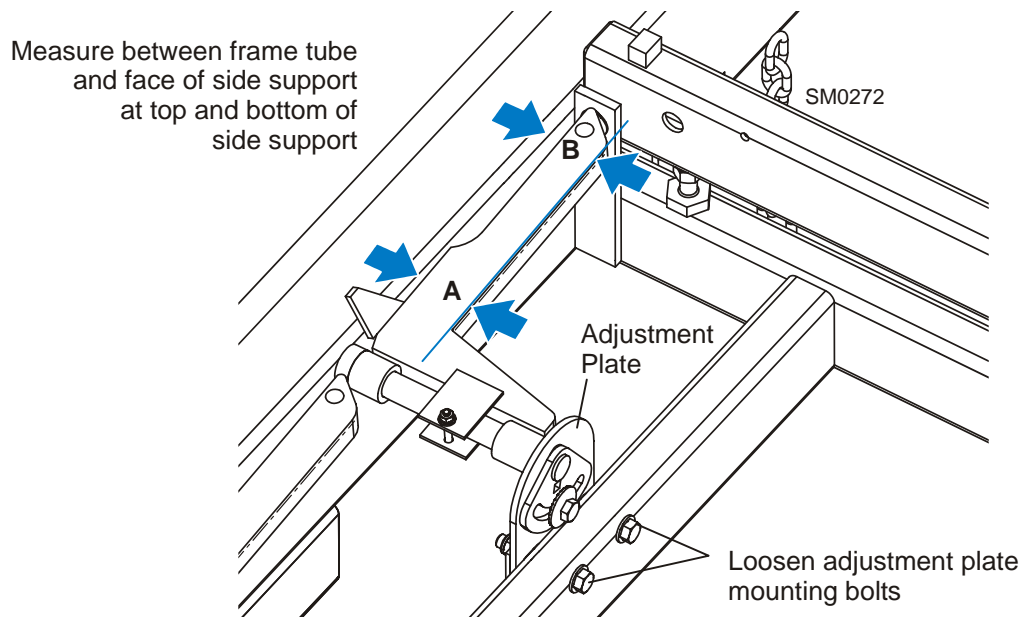
**FIG. 7-13**

2. Repeat the horizontal check for the remaining side supports. Adjust as necessary.
3. Place square alignment tubes (Part No. S12831 - 2 required) across the bed rails. Swing a side support up so that it is vertical.
4. Pull back at the top of the support to eliminate slack as if a log were being clamped against it.
5. Place a square against the face of the side support. The side support should be square or slightly tilted forward 1/32" (0.8 mm). Adjust the vertical tilt of the side support if necessary.

See **Figure 7-14**. Loosen the side support mounting bolt. Use a 3/8" ratchet to rotate the pin until the side support is square to the bed.

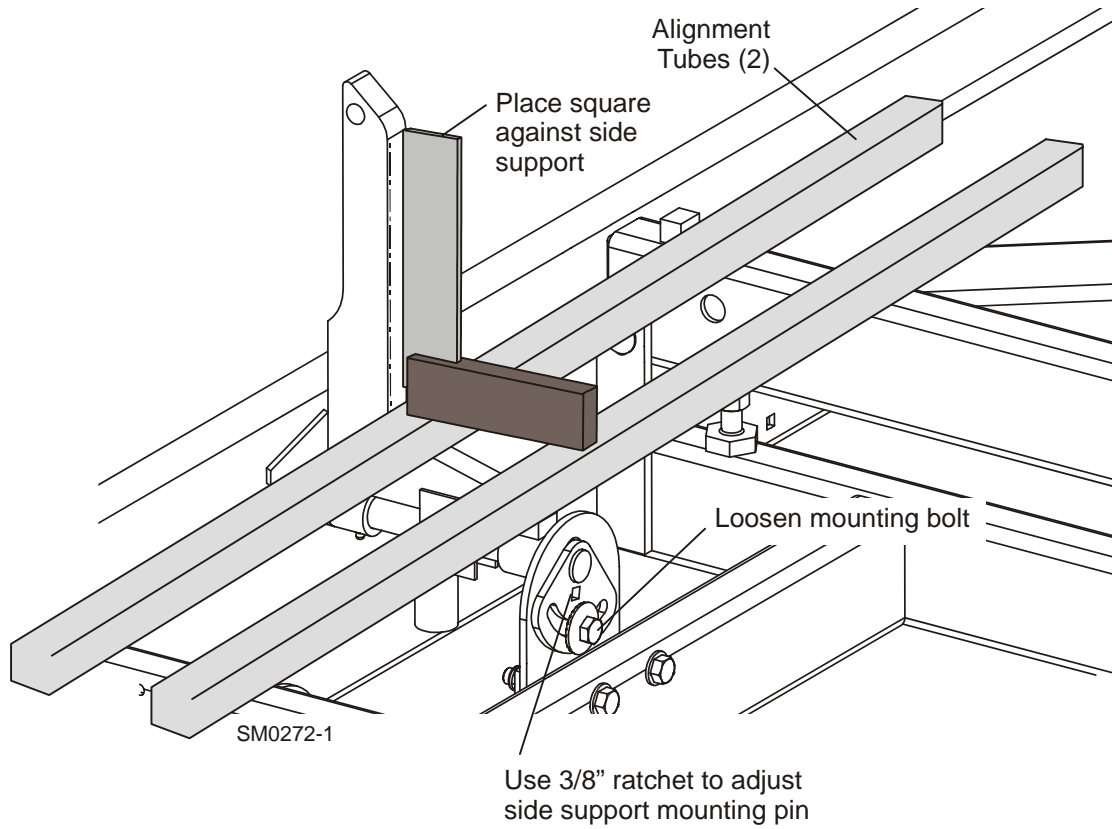

FIG. 7-14

6. Repeat the vertical check for the remaining side supports and adjust as necessary.

7

Sawmill Alignment

Routine Alignment Procedure

Blade Height Scale Adjustment

After the entire sawmill has been aligned and all adjustments made, check that the blade height scale indicates the true distance from the blade to the bed rails.

1. Move the saw carriage so the blade is positioned directly above one of the bed rails. Measure from the bottom edge on a down-set tooth of the blade to the top of the bed rail, near the inner blade guide assembly.
2. View the blade height scale with eyes level with the indicator. The scale should indicate the actual distance from the blade to the bed rail. Adjust the indicator if necessary.

See Figure 7-15. Loosen the indicator bracket mounting bolts. Adjust the bracket up or down until the indicator is aligned with the correct mark on the scale (+0 -1/32 [0.8 mm]). Retighten the bracket mounting bolts.

For example, if the measurement from the down-set tooth of the blade to the bed rail was 14 3/4" (375 mm), make sure the indicator reads 14 3/4" (375 mm) on the scale.

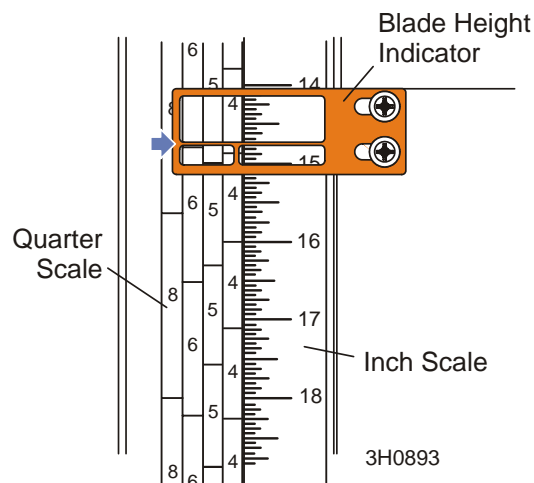

FIG. 7-15

7.2 Complete Alignment Procedure

Frame Setup

Before performing the following alignment procedures, setup the mill on firm, level ground.

If your sawmill is stationary, with no trailer axle, shim the feet so the weight of the sawmill is evenly supported.

If your sawmill has a trailer axle and adjustable outriggers, adjust the outriggers as follows:

LT30HD Super: Adjust the two outriggers on the main frame tube down just enough to lift weight from the trailer tire.

LT40HD Super: Adjust the front and third outriggers on the main frame tube down just enough to lift weight from the trailer tire.

All Portable Sawmills: Adjust the two outer outriggers down just so they touch the ground but do not bear weight.

[See SECTION 3](#) for additional setup information.

7 Sawmill Alignment

Complete Alignment Procedure

Blade Installation

1. Remove the blade and replace the blade wheel belts. New blade wheel belts are required to perform the complete alignment procedure.
2. Blow sawdust off of the blade guide assemblies. Remove sawdust from the blade housings.
3. Remove the blade guide assemblies.

NOTE: To remove the blade guide assemblies and maintain the tilt adjustments, only loosen one side screw and the top screw. Leaving the other side screw and bottom screw in position will insure you will return the rollers to their original tilt adjustment.

4. Adjust the outer blade guide arm in or out until the outer blade guide is approximately 24" from the inner blade guide.
5. Install a new blade and apply the appropriate tension ([See Section 3.4](#)).
6. Close the middle blade housing cover and make sure all persons are clear of the open side of the saw head.
7. Start the engine (or motor).
8. Engage the blade, rotating the blade until the blade positions itself on the wheels.



WARNING! Do not spin the blade wheels by hand. Spinning the blade wheels by hand may result in serious injury.

9. Disengage the blade. Turn the engine off and remove the key.

Saw Head Slide Pad Adjustment

There are eight nylon pads positioned between the saw head frame and vertical mast. The spacing of the pads is factory set and rarely needs adjusting. To check the pad spacing, perform the following steps.

NOTE: The pads on the engine side of the mast are referred to as the “inner” pads. The pads on the control side of the mast are referred to as the “outer” pads.

NOTE: Shims are often used around the clamping bolts, between the C-frame support bracket and the mast v-brace. The shims align the v-brace to the mast so that the entire face of each slide pad makes contact with the mast. Be sure to keep these shims in place when performing the following adjustment.

See Figure 7-16.

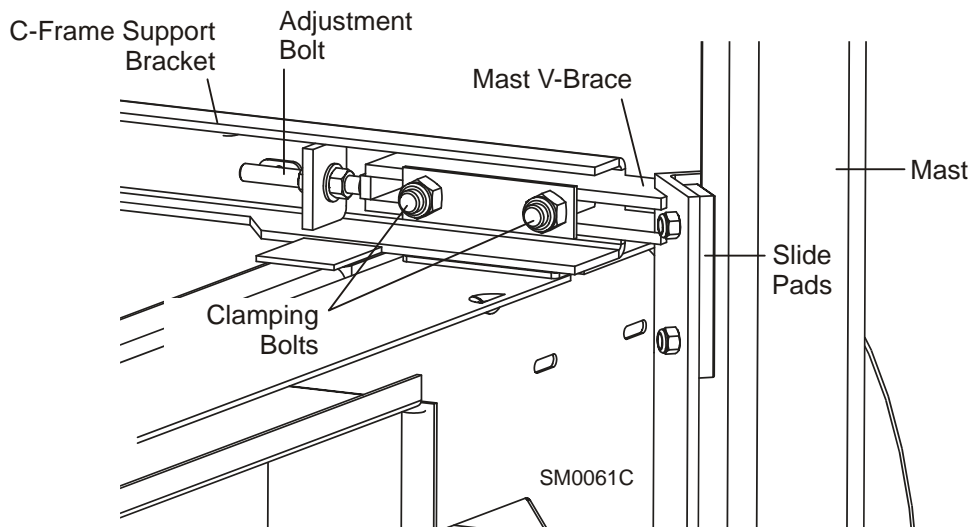

FIG. 7-16

1. Raise the saw head to the top of the vertical mast and secure the saw head with a chain at the top. Check the top set of four pads. The outer two pads should be touching the mast rails. There should be a small gap (just wide enough to slide a business card through) between one of the inner pads and the mast rail.



WARNING! Always secure the saw head with a 5/16" chain with at least 1900 lbs. working load capacity before adjusting the mast pads. The cutting head may fall, causing severe injury or death.

2. Make sure the saw head is adjusted up off the safety chain to ensure the chain is not affecting the alignment of the mast pads.

7 Sawmill Alignment

Complete Alignment Procedure

3. To adjust the spacing of the upper set of pads, lower the saw head until you can access the upper slide pad adjustment bolts.
4. Loosen the upper locking bolts and turn the adjusting bolt as necessary to provide the pad spacing described in Step 1.
5. Lower the saw head to the bottom of the vertical mast. Check the bottom set of four pads.

There should be a small gap between one of the outer pads and the mast rail. The gap should be just wide enough to slide a business card through. The inner two pads should be touching the mast rails. To adjust the spacing of the lower set of pads, raise the saw head until you can access the lower slide pad adjustment bolts.

6. Loosen the lower locking bolts and turn the adjusting bolt as necessary to provide the pad spacing described in Step 5.



CAUTION! Due to variations in the vertical mast, the pad spacing may vary throughout the travel of the saw head. Check the pad spacing at the top and bottom ends of the mast only. Pads adjusted too tight will cause premature up/down motor failure.

Blade Wheel Alignment

The blade wheels should be adjusted so they are level in the vertical and horizontal planes. If the blade wheels are tilted up or down, the blade will want to travel in the tilted direction. If the blade wheels are tilted horizontally, the blade will not track properly on the wheels.

1. Use the blade guide alignment tool to check the vertical alignment of each blade wheel. Attach the tool to the blade near the inner blade guide mount. Be sure the tool does not rest on a tooth or burr, and is lying flat against the bottom of the blade.

See Figure 7-17.

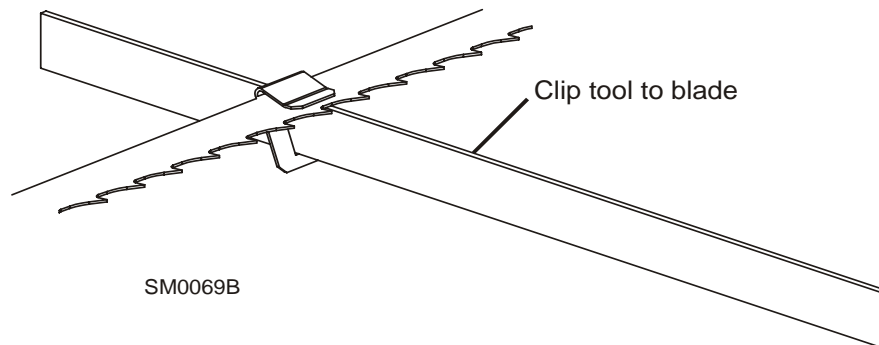

FIG. 7-17

2. Move the saw carriage so the front end of the tool is positioned over the first bed rail. Measure from the bottom of the tool to the top surface of the bed rail.
3. Move the saw carriage so the rear of the tool is positioned over the bed rail. Again, measure from the bottom of the tool to the bed rail.
4. If the two measurements differ by more than 1/16" (1.5 mm), adjust the vertical tilt of the drive-side blade wheel.

See Figure 7-18. Use the vertical adjustment screws to adjust the drive-side blade wheel. To tilt the wheel up, loosen the top adjustment screw one quarter turn. Loosen the jam nut on the bottom adjustment screw and tighten the screw to 30 ft.-lbs torque. Tighten the top and bottom jam nuts.

To tilt the wheel down, loosen the bottom adjustment screw one quarter turn. Loosen the jam nut on the top adjustment screw and tighten the screw to 30 ft.-lbs torque. Tighten the top and bottom jam nuts.

7 Sawmill Alignment

Complete Alignment Procedure

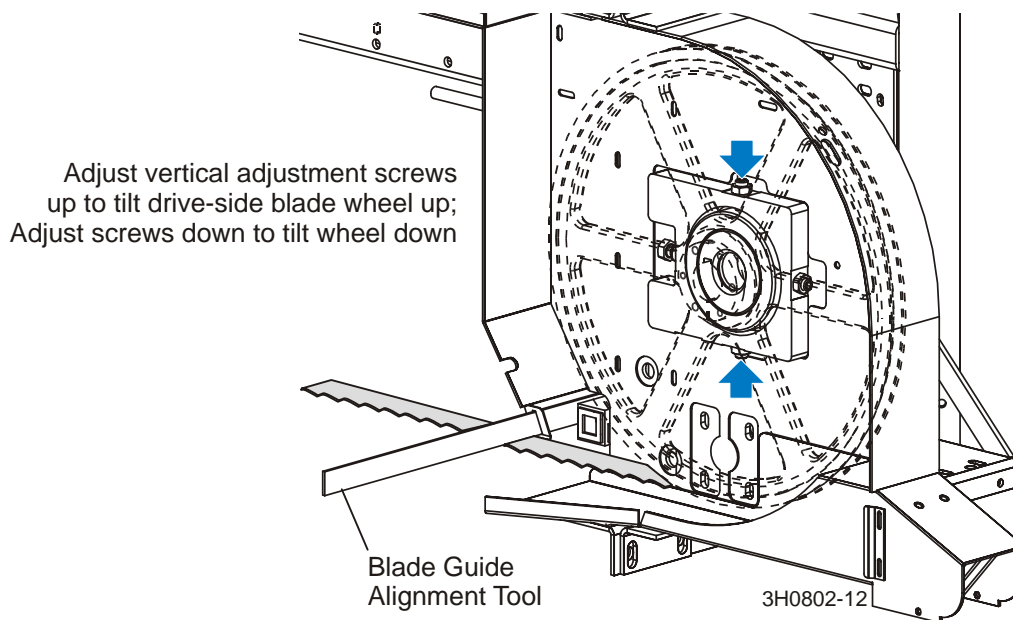

FIG. 7-18

5. Recheck the vertical tilt of the drive-side blade wheel with the blade guide alignment tool. Readjust the blade wheel as necessary until the front and rear of the tool are the same distance from the bed rail (within 1/16" [1.5 mm]).
6. Remove the tool from the blade and reattach it near the outer blade guide assembly.
7. Measure from the tool to the bed rail at both ends of the tool. If the measurements at the front and rear ends of the tool differ by more than 1/16" (1.5 mm), adjust the vertical tilt of the idle-side blade wheel.

See Figure 7-19. Use the vertical adjustment screws to adjust the idle-side blade wheel. To tilt the wheel up, loosen the bottom adjustment screw one quarter turn. Loosen the jam nut on the top adjustment screw and tighten the screw. Tighten the top and bottom jam nuts.

To tilt the wheel down, loosen the top adjustment screw one quarter turn. Loosen the jam nut on the bottom adjustment screw and tighten the screw. Tighten the top and bottom jam nuts.

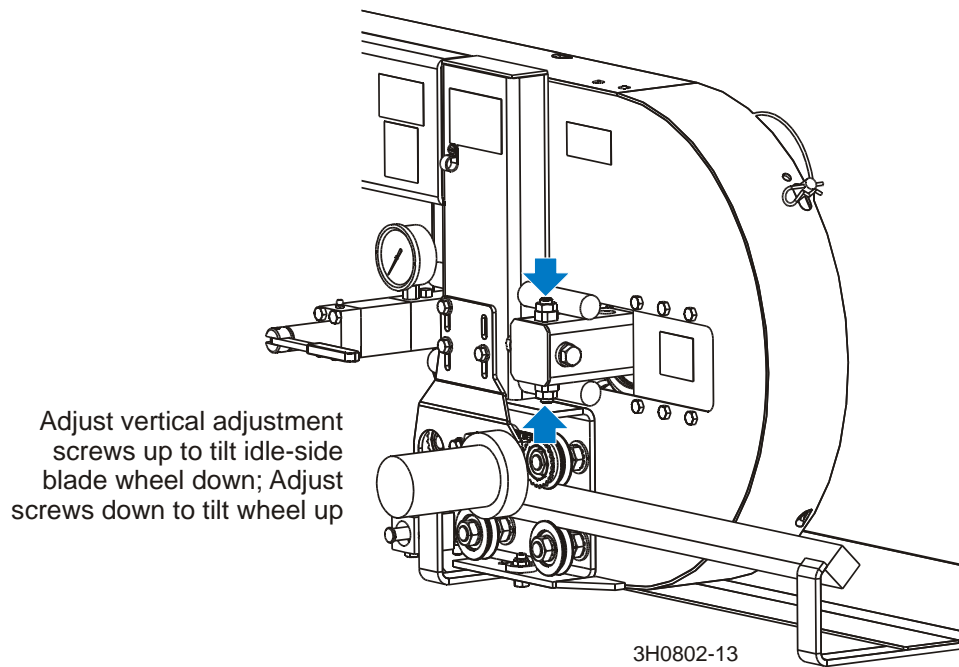

FIG. 7-19

8. Recheck the vertical tilt of the idle-side blade wheel with the blade guide alignment tool. Readjust the blade wheel as necessary until the front and rear of the tool are the same distance from the bed rail (within 1/16" [1.5 mm]).

7 Sawmill Alignment

Complete Alignment Procedure

9. Check the position of the blade on the idle-side blade wheel.

See Figure 7-20. The horizontal tilt of the blade wheel should be adjusted so that the gullet of a 1-1/4" blade is 1/8" (3 mm) out from the front edge of the wheel ($\pm 1/16$ " [1.5 mm]). The gullet of a 1-1/2" blade should be 3/16" (4.5 mm) out from the front edge of the wheel ($\pm 1/16$ " [1.5 mm]). Do not let the teeth ride on the wheels.

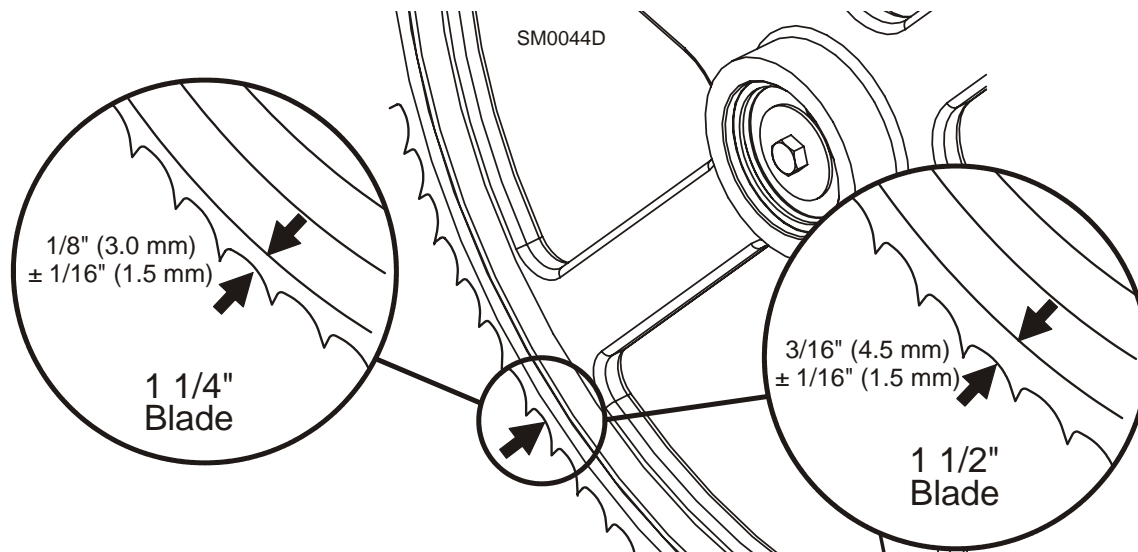
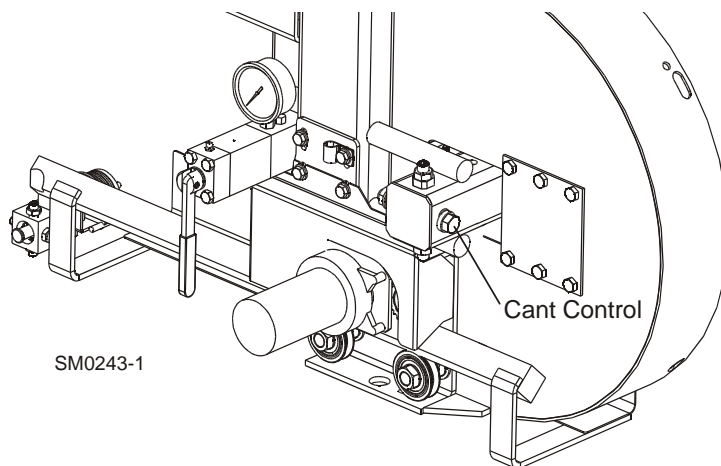

FIG. 7-20

See Figure 7-21. Use the cant control adjustment to adjust the idle-side blade wheel. If the blade is too far forward on the wheel, turn the cant control counterclockwise. If it is too far back on the wheel, turn the cant control clockwise.



Turn cant control clockwise to move blade out on wheel; counterclockwise to move blade back on wheel

FIG. 7-21

10. Check the position of the blade on the drive-side blade wheel. The blade should be positioned on the wheel as described for the idle-side blade wheel. Adjust the drive-side blade wheel if necessary.

See Figure 7-22. Use the horizontal adjustment screws to adjust the drive-side blade wheel. To move the blade back on the wheel, loosen the right adjustment screw one quarter turn. Loosen the jam nut on the left adjustment screw and tighten the screw to 30 ft.-lbs torque. Tighten the left and right jam nuts.

To move the blade out on the wheel, loosen the left adjustment screw one quarter turn. Loosen the jam nut on the right adjustment screw and tighten the screw to 30 ft.-lbs torque. Tighten the left and right jam nuts.

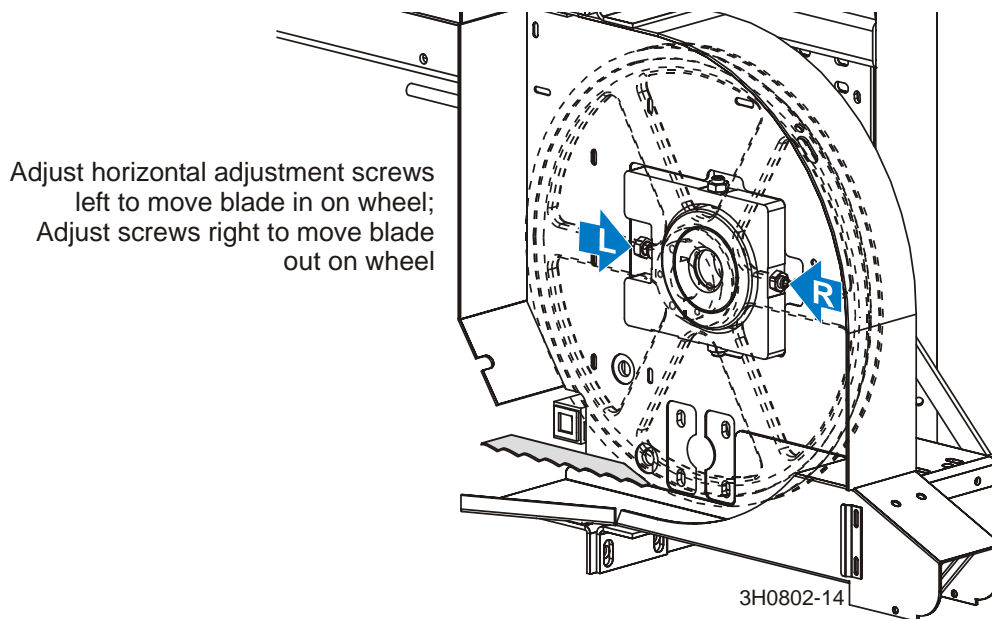

FIG. 7-22

7 Sawmill Alignment

Complete Alignment Procedure

Track Roller Adjustment

Making these adjustments correctly will insure the saw carriage travels smoothly along the track and blade will remain parallel with the bed frame.

1. Using the feed controls, move the saw carriage so that the blade is positioned over the front pivot end rail.
2. Check the lower stop blocks on the bottom track rail. Make sure that the stop blocks are adjusted $1/32''$ - $1/16''$ (.75mm - 1.5mm) from the track rail. Use the vertical bolts to adjust the stop blocks.

See Figure 7-23. Tighten the vertical adjustment bolt to move the stop block toward the track rail. Loosen the bolt to move the stop block away from the track rail.

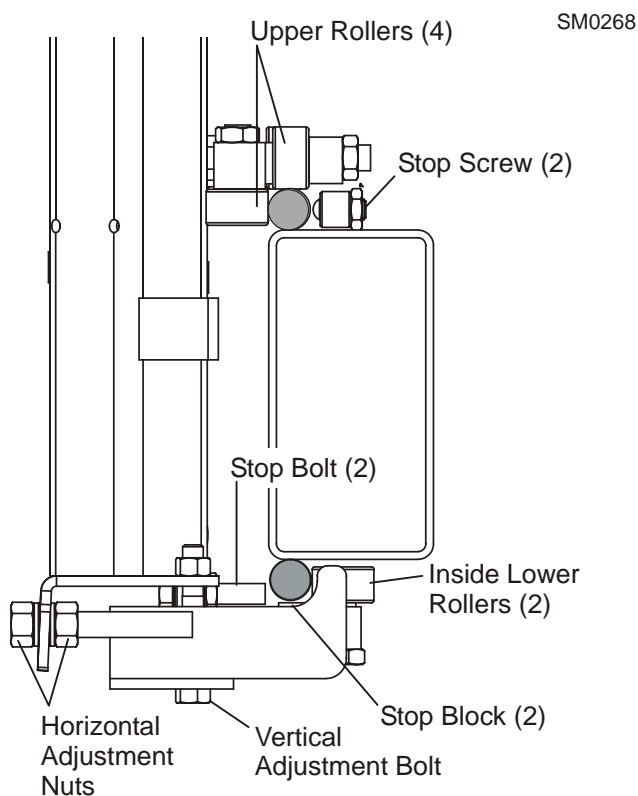

FIG. 7-23

3. Check the inside lower rollers. Both inside rollers should touch the rail so that you cannot spin them by hand. If the rollers are not adjusted evenly and you can spin one, adjust the horizontal adjustment nuts until the roller cannot be spun by hand. Stop adjusting before the other roller can be spun by hand. The two inside rollers should bear the weight of the saw carriage evenly.

4. Move the carriage forward until the blade is positioned over the rear pivot end rail. Repeat steps 2 & 3 until all lower rollers are adjusted properly at the front and rear of the sawmill.
5. Open the adjustable blade guide arm to within 1/2" (15 mm) of full open.
6. Move the carriage back to the front pivot end rail. Raise the cutting head until the bottom of the blade is 17" (400 mm) above the outside of the pivot rail support by actual measurement with a tape or ruler.

See Figure 7-24.

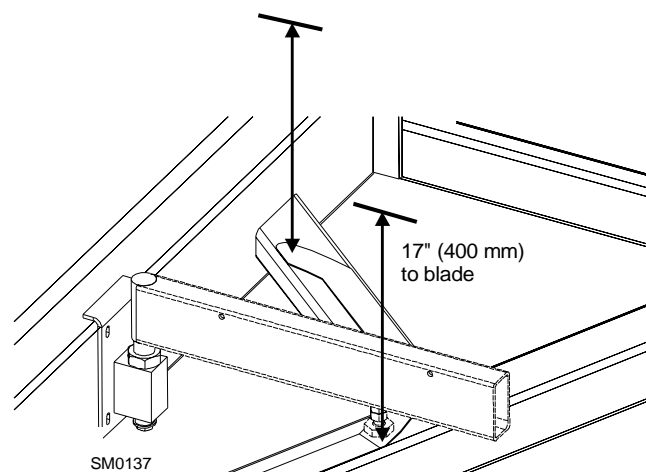

FIG. 7-24

7. Move the carriage forward to check the distance to the blade at the inside of the pivot rail support. All measurements should be equal within 1/32" (0.8 mm).

7 Sawmill Alignment

Complete Alignment Procedure

See Figure 7-25. To adjust the saw head tilt, use the horizontal adjustment nuts. To raise the outside of the saw head, loosen the four inner adjustment nuts 1/2 turn then tighten the four outer nuts. To lower the outside of the saw head, loosen the four outer adjustment nuts 1/2 turn then tighten the inner nuts. Recheck the saw head tilt and readjust the nuts as necessary.

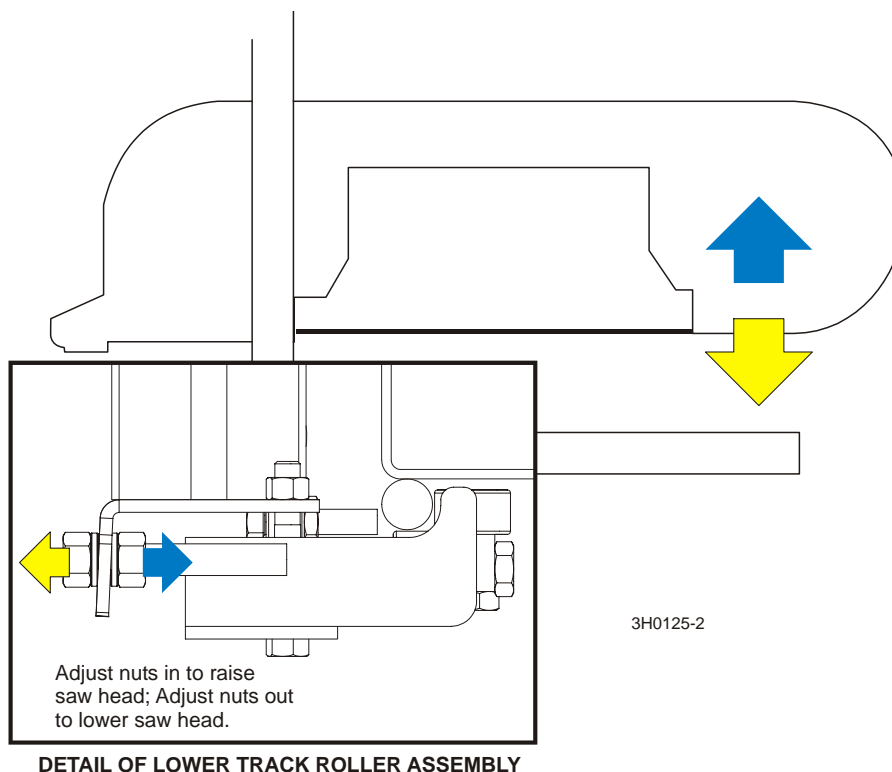

FIG. 7-25

- After the lower track rollers are adjusted properly, adjust the upper and lower stop screws. Tighten each screw until it just touches the rail. Then, back the screw off 1/2 turn. The gap will be approximately 1/32" (0.8mm).



CAUTION! It is important that the lower stop bolts are properly adjusted to secure the carriage on the track rail. Failure to properly adjust the stop bolts can cause saw head damage, especially during mill transportation.

Bed Rail Adjustment

1. Move the clamp so it is 10" from the clamp stop. Adjust the clamp down to its lowest position. Move the saw head forward until it is positioned over the clamp. Raise the saw head until the blade measures 15 5/16" (385 mm) from the clamp at its lowest position.
2. Adjust the front pivot rail 90° to the main bed tube.
3. Move the saw head to center the blade over the front pivot bed rail.
4. Measure the distance from the top of the pivot rail to the bottom of the blade. Make this measurement at each end of the pivot rail.
5. The two measurements should be 15" (375 mm) (+1/32 [0.8 mm] -0).

See Figure 7-26. Loosen the locking set screws and turn the inner height adjustment nut to adjust the height of the inner end of the pivot rail. Loosen the jam nut and turn the outer adjustment bolt to adjust the height of the outer end of the pivot rail.

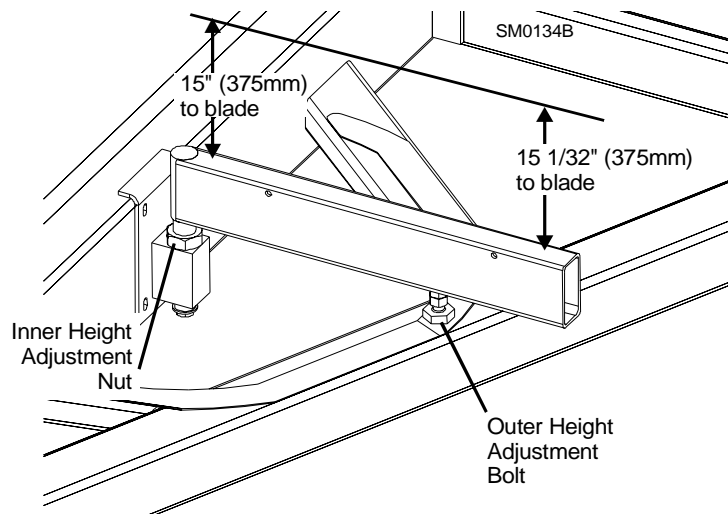

FIG. 7-26

6. Move the saw head so the blade is positioned over the center of the front main bed rail.
7. Measure the distance between the bottom of the blade and the bed rail at each end of the bed rail. The bed rail should measure 15" (375 mm) (+1/32 [0.8 mm] -0) from the blade at each end of the rail.

7 Sawmill Alignment

Complete Alignment Procedure

See **Figure 7-27**. Loosen the bed rail clamping bolts and turn the adjustment bolts to move the bed rails to the blade if necessary. Retighten the clamping bolts and adjustment bolt jam nuts.

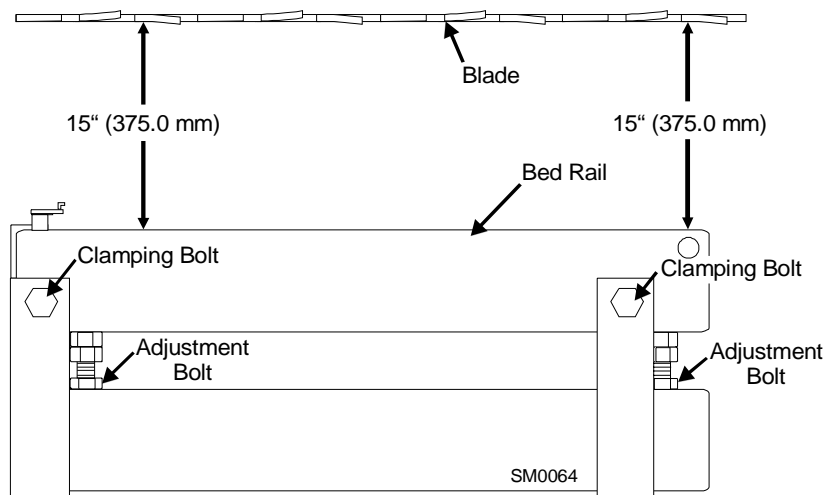

FIG. 7-27

- Without adjusting the saw head height, check the three remaining main bed rails and the rear pivot rail. Adjust them so that all measure the same distance from the blade at both ends of the bed rail.

Blade Guide Installation

Each Wood-Mizer sawmill has two blade guide assemblies that help the blade maintain a straight cut. The two blade guide assemblies are positioned on the saw head to guide the blade on each side of the material being cut.

One blade guide assembly is mounted in a stationary position on the drive side of the saw head. This assembly is referred to as the "inner" blade guide assembly.

The other blade guide assembly is mounted on the idle side of the saw head. It is referred to as the "outer" assembly and is adjustable for various widths of materials to be processed.

NOTE: Before installing the blade guide assemblies, remove the blade guide adjusting screws and apply a lubricating oil such as 10W30 or Dexron III to each screw. This will prevent the screws and threaded holes from corroding and make screw adjustments easier.

NOTE: If blade guides equipped with optional high-performance blocks, remove the blade from the sawmill before installing the blade guide assemblies. Place both guide assemblies in the mounts then reinstall, tension and track the blade properly.

Blade guides equipped with High-Performance blocks:

1. Inspect the guide blocks and repair or replace as necessary. Remove the blade from the sawmill.

See Figure 7-28.

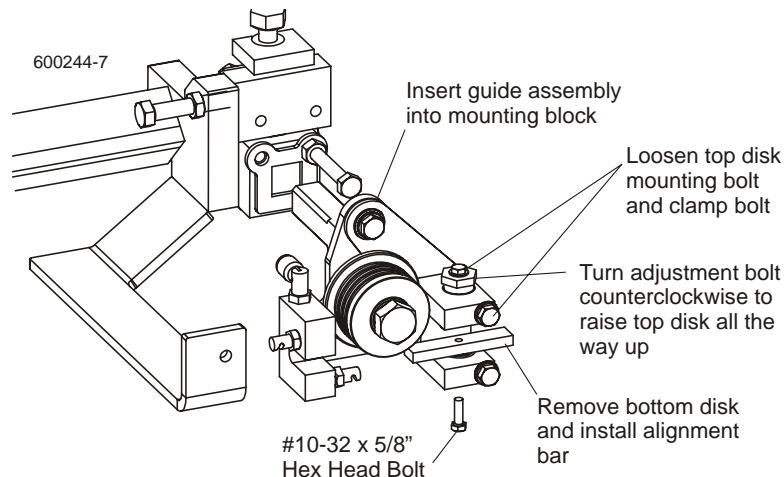

FIG. 7-28 REV. K1.01 - K3.02 (OPTIONAL HIGH-PERFORMANCE ROLLER/BLOCKS SHOWN)

7 Sawmill Alignment

Complete Alignment Procedure

2. Loosen the top block clamp bolt and mounting bolt. Turn the adjustment bolt counter-clockwise to raise the top block all the way up. Remove the bottom guide block from each blade guide assembly and install the provided alignment bar.
3. Install each blade guide assembly to the mounting blocks and push all the way back. Install, tension and track a new blade. Adjust the outer blade guide assembly so the roller flange is 1/8" from the back of the blade. Adjust the inner blade guide assembly so the roller flange is 1/16" from the blade.

Blade guides not equipped with High-Performance blocks:

1. Install the outer blade guide assembly (with waterlube tube) to the mounting block on the blade guide arm. Position the assembly so the roller flange is 1/8" (3.0 mm) from the blade.
2. Install the inner blade guide assembly to the mounting block on the saw head. Position the assembly so the roller flange is 1/16" (1.5 mm) from the blade.

See **Figure 7-29**. Tighten the two previously-loosened tilt adjustment screws to secure the blade guide assembly.

Rev. K1.01 - K3.02: Turn the top adjustment bolt clockwise to raise the blade guide assembly so the roller does not contact the blade.

NOTE: Before adjusting the top bolt, unload pressure on the bolt by turning 1/2 turn in the opposite direction it was last adjusted.

With the roller flange positioned properly from the back of the blade, adjust the stop bolt so it touches the blade guide bracket.

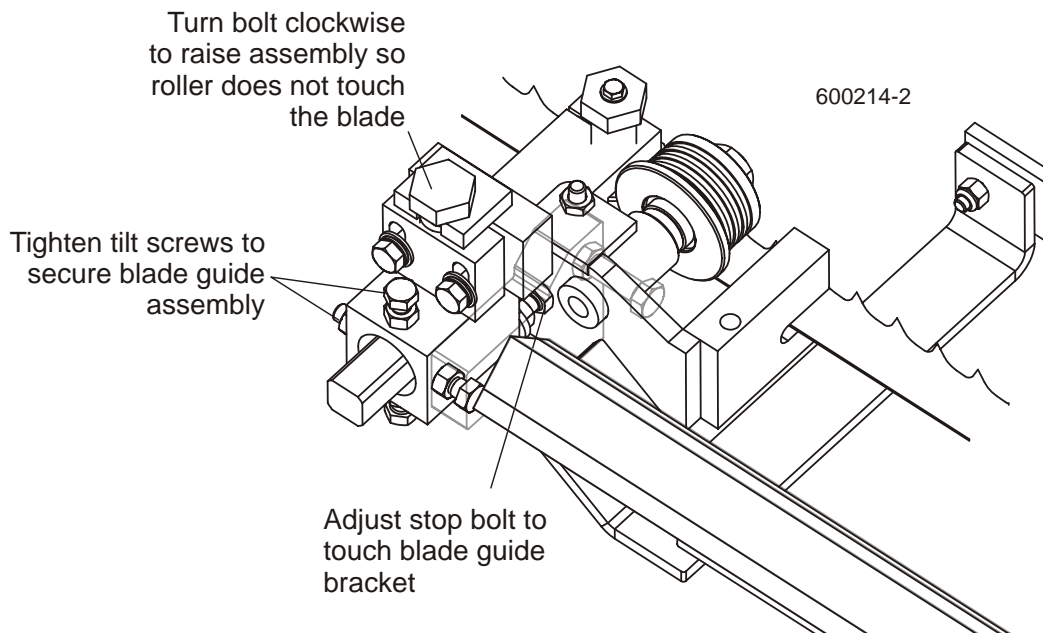
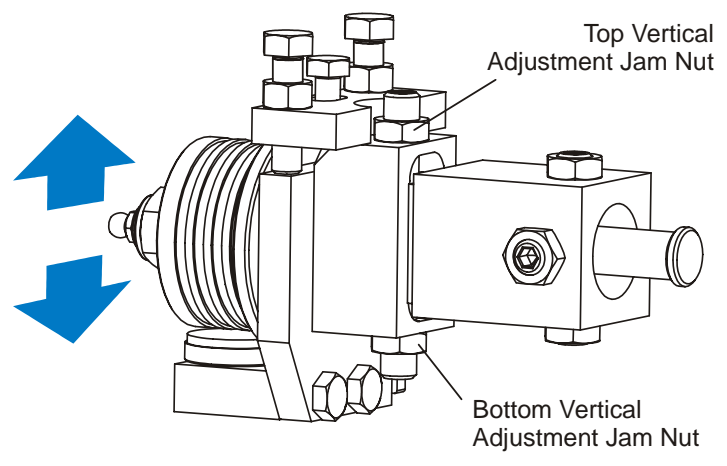

FIG. 7-29

Sawmills prior to Rev. K1.01: Loosen the top vertical adjustment jam nut and tighten the bottom vertical adjustment jam nut to adjust the blade guide roller up so it does not touch the blade.

7 Sawmill Alignment
Complete Alignment Procedure



3H0802-16C

FIG. 7-29

Blade Guide Arm Alignment

The blade guide arm moves the outer blade guide in and out. If the arm becomes loose, the blade guide will not deflect the blade properly, causing inaccurate cuts. A loose blade guide arm can also cause blade vibration.

1. Adjust the blade guide arm in to 1/2" (15 mm) from fully closed.
2. Manually try to move the arm up and down. If you can move the arm by hand, you will need to tighten the arm rollers.

See Figure 7-30. Remove the blade housing cover to access the blade guide arm roller mounting bolts. The blade guide arm rollers are mounted on cam-shaped bolts. Turning the bolts will cause each roller to move up or down. If the inner lower roller is loose, adjust the inner top roller down. If the outer lower roller is loose, adjust the outer lower roller up. Retighten the jam nuts and recheck the tightness of the bottom rollers.

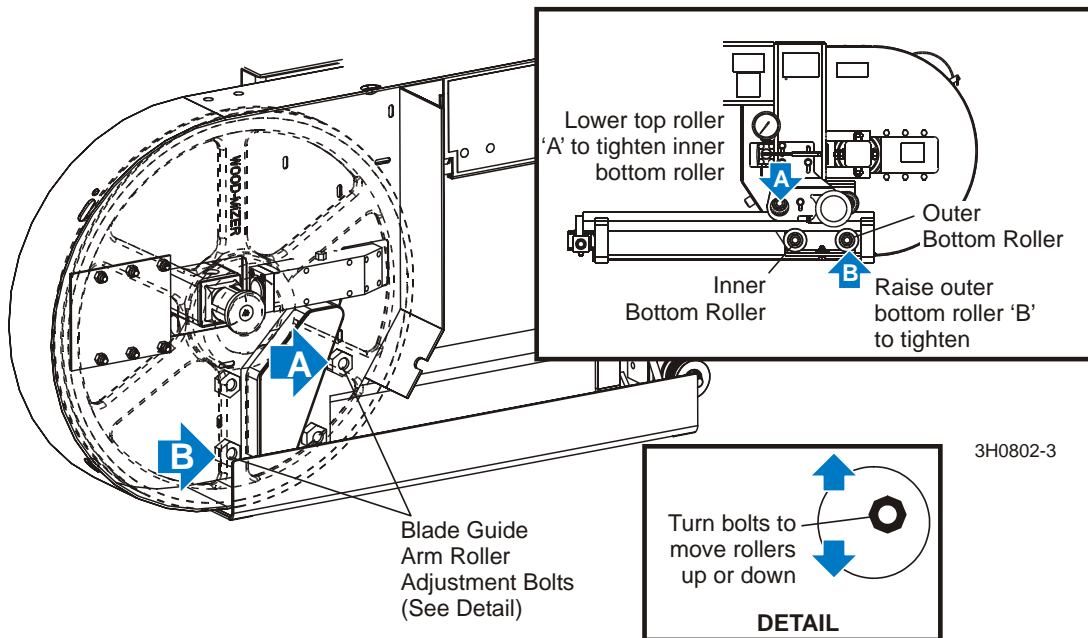

FIG. 7-30

7 Sawmill Alignment

Complete Alignment Procedure

After tightening the blade guide arm rollers, check that the arm is aligned properly.

3. With the arm adjusted 1/2" (15 mm) from fully closed, measure the distance between the blade guide roller flange and the back of the blade.

See Figure 7-31.

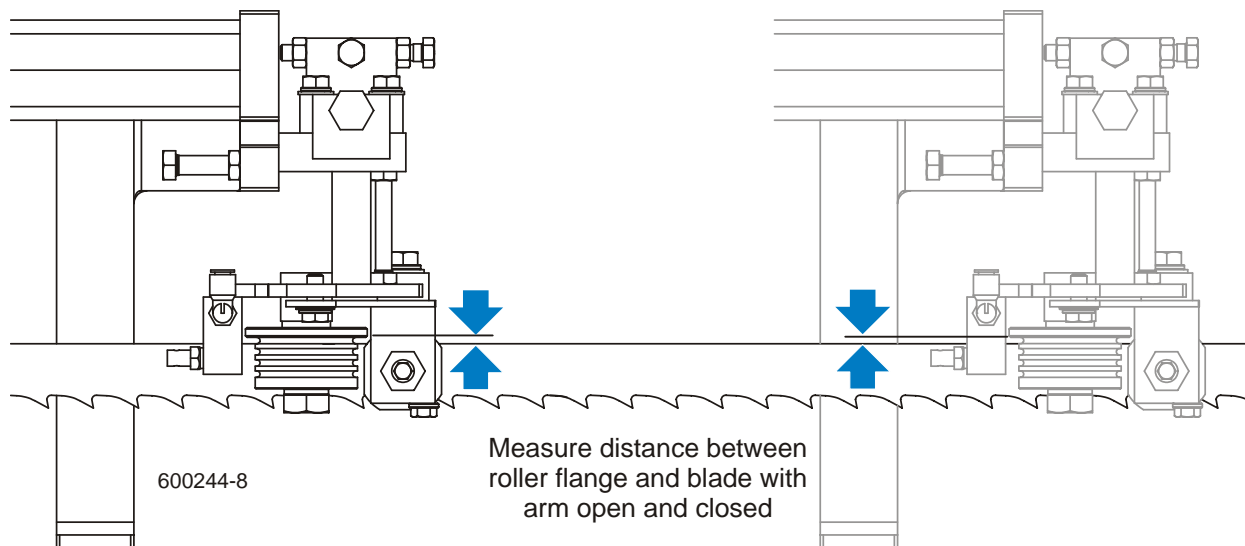

FIG. 7-31 REV. K1.01 - K3.02 (OPTIONAL HIGH-PERFORMANCE ROLLER/BLOCKS SHOWN)

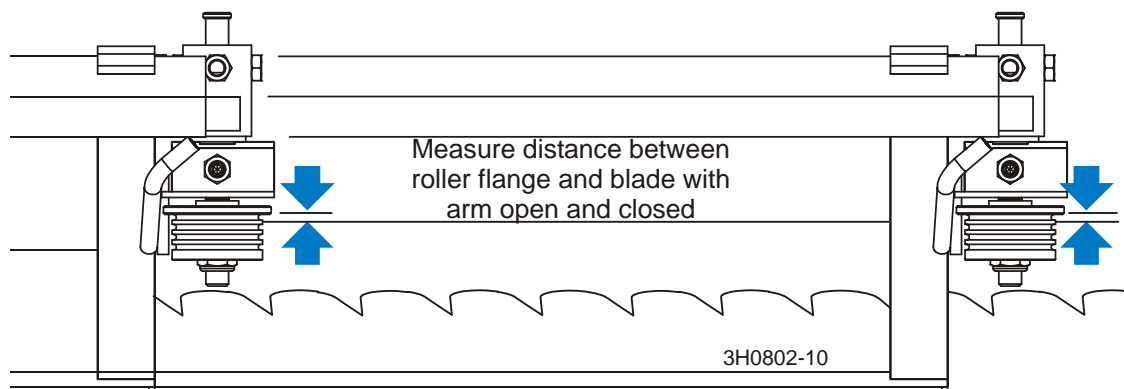

FIG. 7-31 PRIOR TO REV. K1.01

4. Adjust the blade guide arm to 1/2" (15 mm) from fully open and remeasure the distance from the roller flange to the back of the blade. The two measurements should be the same. If not, adjust the inner rollers in or out to tilt the arm horizontally.

See Figure 7-32. To tilt the arm out away from the blade, loosen the front nuts on the inner rollers and tighten the rear nuts. To tilt the arm in toward the blade, loosen the rear nuts on the inner rollers and tighten the front nuts. Recheck the blade guide arm horizontal tilt.

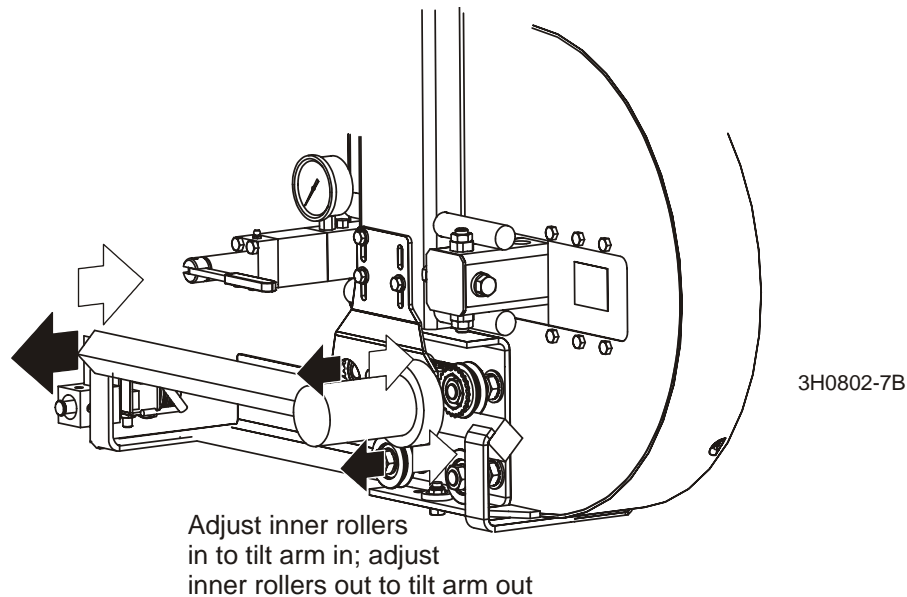

FIG. 7-32

5. Now check the vertical tilt of the blade guide arm. Move the saw carriage so the blade guide arm is positioned over a bed rail.
6. With the arm 1/2" (15 mm) from fully closed, raise or lower the saw head until the bottom of the blade guide block is 15" (375 mm) from the top of the bed rail.

7 Sawmill Alignment

Complete Alignment Procedure

See Figure 7-33. Adjust the blade guide arm to 1/2" (15 mm) from fully open. Measure the distance from the bottom of the blade guide mounting block to the bed rail. This measurement should be 15" (376.5 mm). If the measurements are not the same, adjust the outer rollers up or down to tilt the blade guide arm vertically.

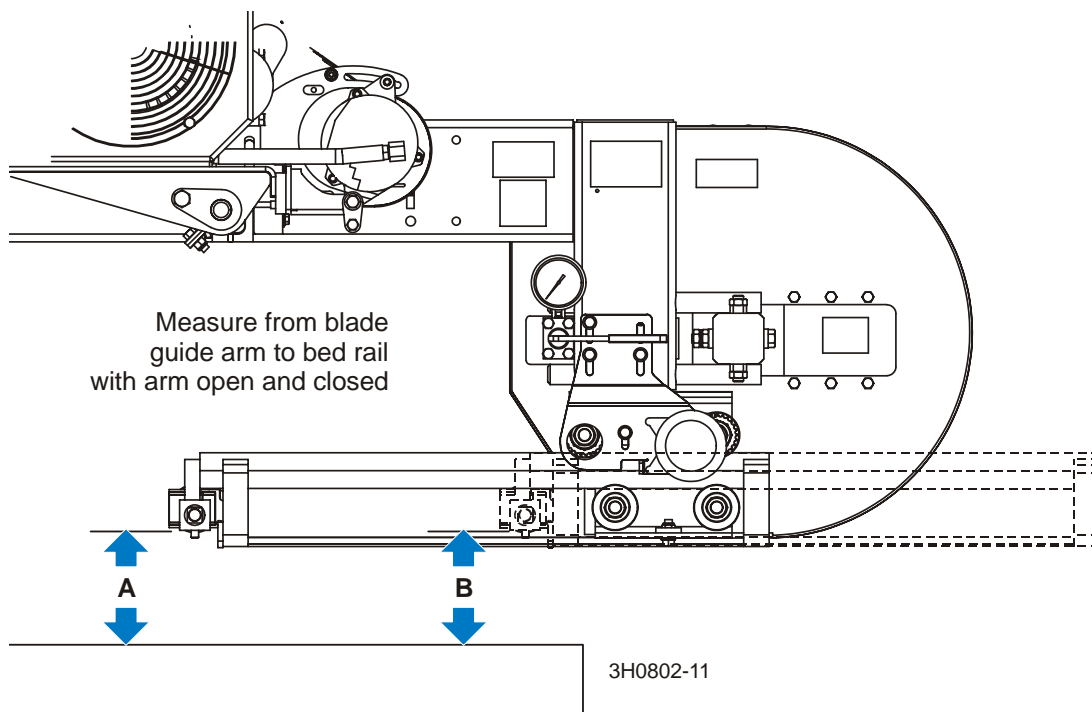

FIG. 7-33

See **Figure 7-34**. Remove the blade housing cover to access the blade guide arm roller mounting bolts. To adjust the rollers, loosen the jam nuts on the other side of the blade housing and turn the mounting bolts. To tilt the blade guide arm down, adjust the outer top and bottom rollers up. To tilt the blade guide arm up, adjust the outer top and bottom rollers down. Retighten the jam nuts and recheck the blade guide arm vertical tilt.

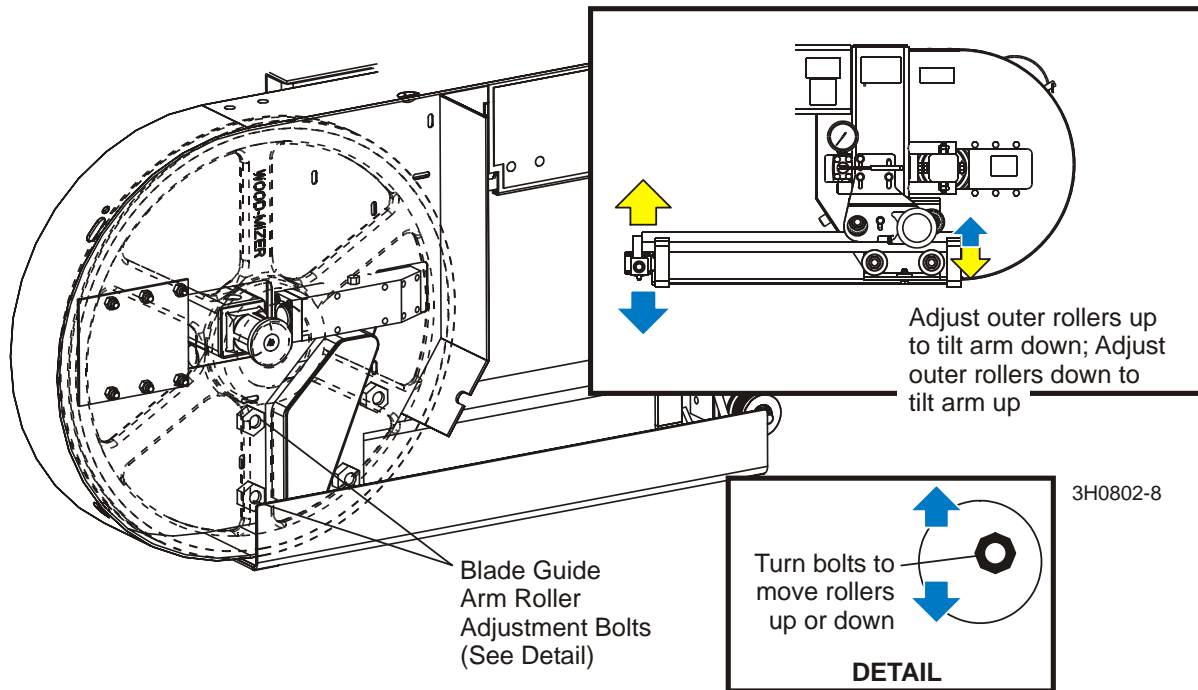

FIG. 7-34

7 Sawmill Alignment

Complete Alignment Procedure

Blade Guide Deflection

Perform the following steps to achieve proper blade deflection with the blade guides.

1. Raise the saw head until the blade is 15" (375 mm) above a bed rail. Measure the actual distance with a tape from the top of the rail to the bottom of the blade.

See Figure 7-35.

Rev. K1.01 - K3.02: Turn the top adjustment bolt counterclockwise to lower the assembly until the blade guide roller deflects the blade down until the bottom of the blade measures 14 3/4" (370 mm) from the bed rail.

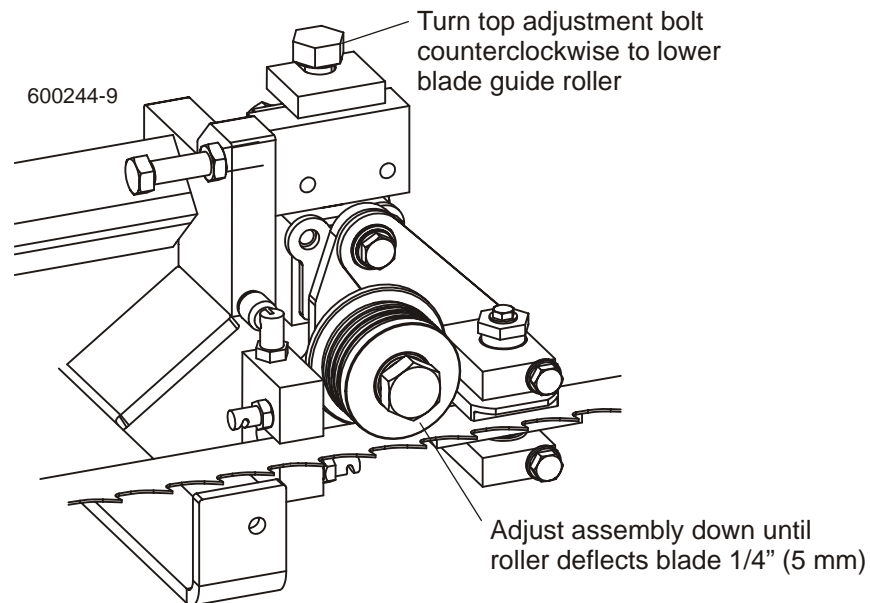

FIG. 7-35

NOTE: Before adjusting the top bolt, unload pressure on the bolt by turning 1/2 turn in the opposite direction it was last adjusted.

Sawmills prior to Rev. K1.01: Loosen the bottom jam nut and tighten the top jam nut until the blade guide deflects the blade down until the bottom of the blade measures 14 3/4" (370 mm) from the bed rail.



CAUTION! Be careful when tightening the vertical adjustment screws. The screws may shear.

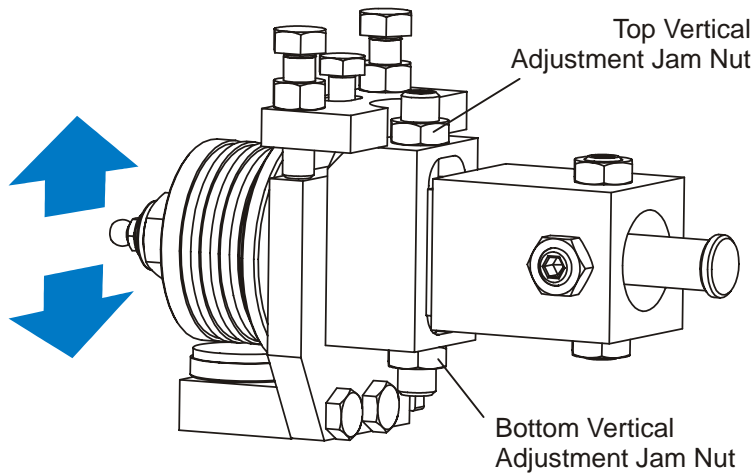

3H0802-16C

FIG. 7-35

2. Repeat for the other blade guide.

7 Sawmill Alignment

Complete Alignment Procedure

Blade Guide Vertical Tilt Alignment

The blade guides should be adjusted properly in the vertical plane. If the blade guides are tilted vertically, the blade will try to travel in the tilted direction.

A Blade Guide Alignment Tool (BGAT) is provided to help you measure the vertical tilt of the blade.

1. Open the adjustable blade guide arm 1/2" (15 mm) from full open.
2. Clamp the alignment tool on the blade. Position the tool close to the outer blade guide roller. Be sure the tool does not rest on a tooth or burr, and is lying flat on the blade.

See Figure 7-36.

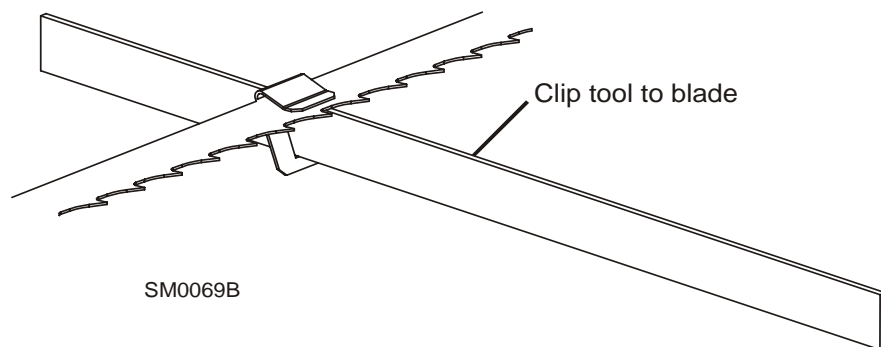

FIG. 7-36

3. Move the carriage so that the front end of the tool is positioned above the bed rail. Measure the distance from the bed rail to the bottom edge of the tool.
4. Move the carriage so that the back end of the tool is positioned above the bed rail. Measure the distance from the bed rail to the bottom edge of the tool.
5. If the measurement from the tool to the bed rail is not equal within 1/32" (.75 mm), adjust the vertical tilt of the outer blade guide roller.
6. Loosen one set screw at the side of the blade guide assembly.

See Figure 7-37. Loosen the jam nuts on the top and bottom vertical tilt adjustment screws. To tilt the roller up, loosen the bottom screw and tighten top screw. To tilt the roller down, loosen the top screw and tighten the bottom screw. Tighten the jam nuts and recheck the tilt of the blade.

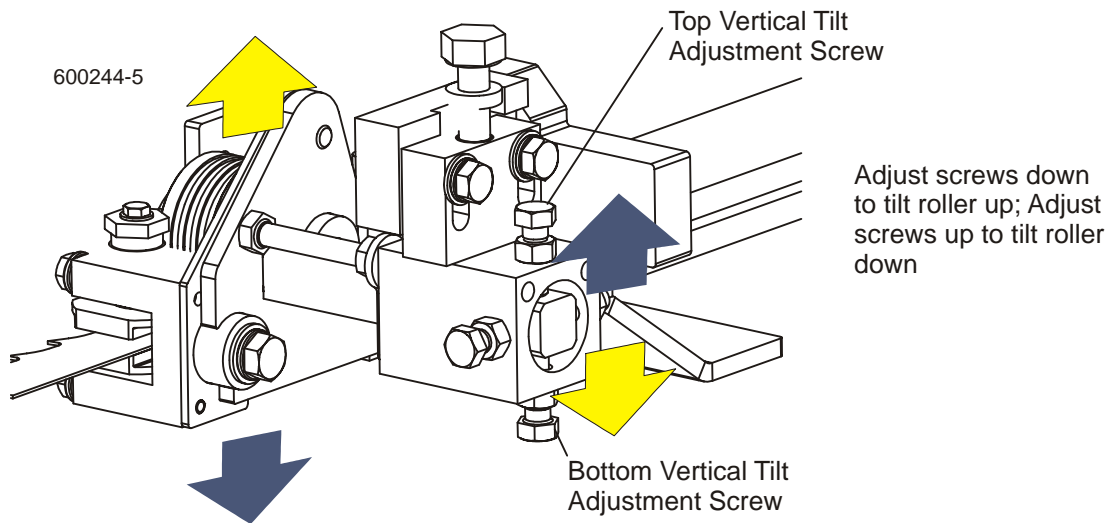

FIG. 7-37 REV. K1.01 - K3.02 (OPTIONAL HIGH-PERFORMANCE ROLLER/BLOCKS SHOWN)

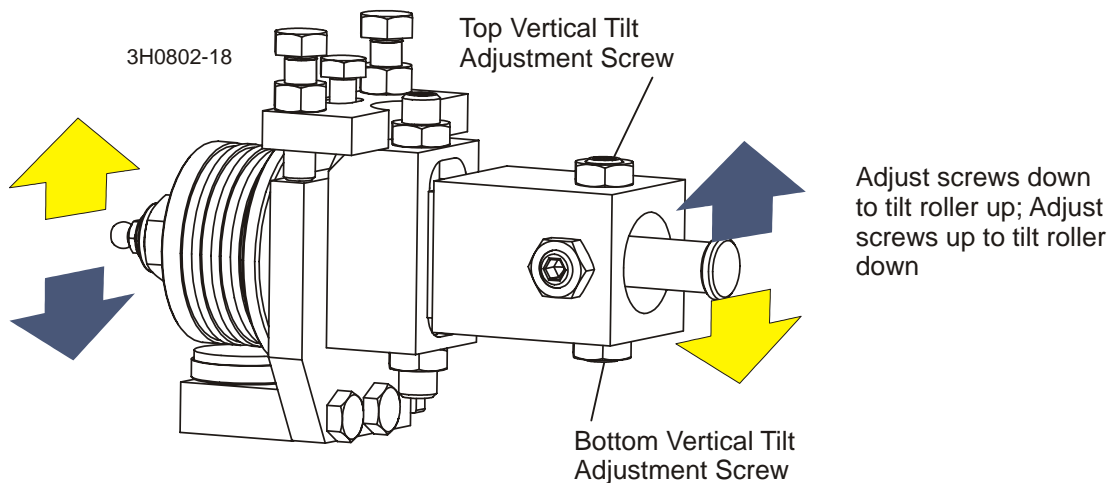

FIG. 7-37 PRIOR TO REV. K1.01

7. Move the blade guide alignment tool close to the inner blade guide roller assembly and repeat the above steps. Adjust the vertical tilt of the inner blade guide if necessary.
8. After adjusting the vertical tilt of the blade guides, recheck the blade deflection and adjust if necessary.

7 Sawmill Alignment

Complete Alignment Procedure

Blade Guide Horizontal Tilt Adjustment

If the blade guides are tilted in the wrong direction horizontally, the back of the blade may contact the flange as the roller is spinning down, causing it to push the blade away from the guide roller.

1. Remove the blade guide alignment tool from the blade and adjust the blade guide arm halfway in.
2. Remove the clip from the blade guide alignment tool. Place the tool against the face of the outer blade guide roller.

See Figure 7-38.

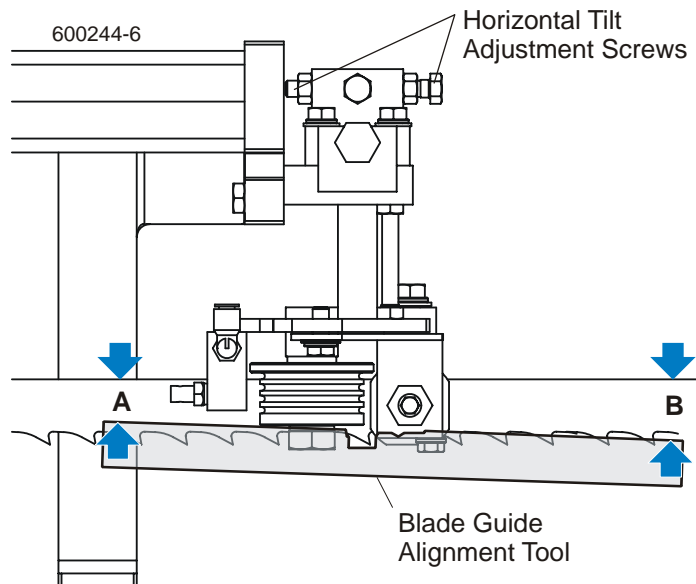

FIG. 7-38 REV. K1.01 - K3.02 (OPTIONAL HIGH-PERFORMANCE ROLLER/BLOCKS SHOWN)

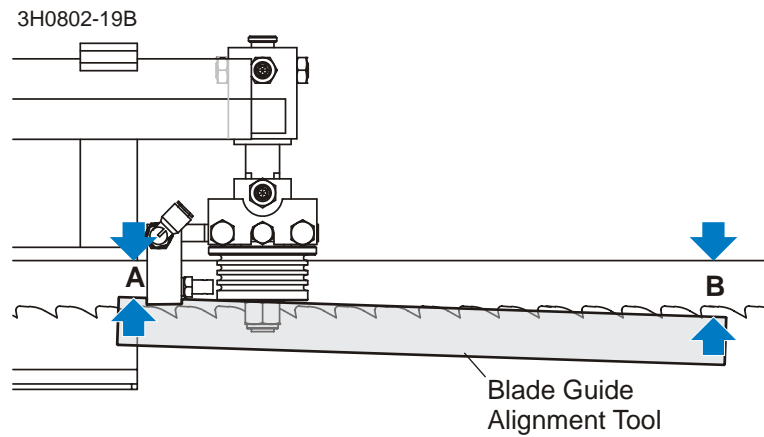

FIG. 7-38 PRIOR TO REV. K1.01

3. Measure between the back edge of the blade and the tool at the end closest to the inner blade guide ("B").
4. Measure between the back edge of the blade and the other end of the tool ("A").

The roller should be tilted slightly to the left ('A' 1/8" [3 mm] less than 'B' \pm 1/8" [3 mm]).

7 Sawmill Alignment

Complete Alignment Procedure

See **Figure 7-39**. Loosen the jam nuts on the horizontal tilt adjustment screws. To tilt the roller left, loosen the right screw and tighten left screw. To tilt the roller right, loosen the left screw and tighten the right screw. Tighten the jam nuts and recheck the tilt of the blade.

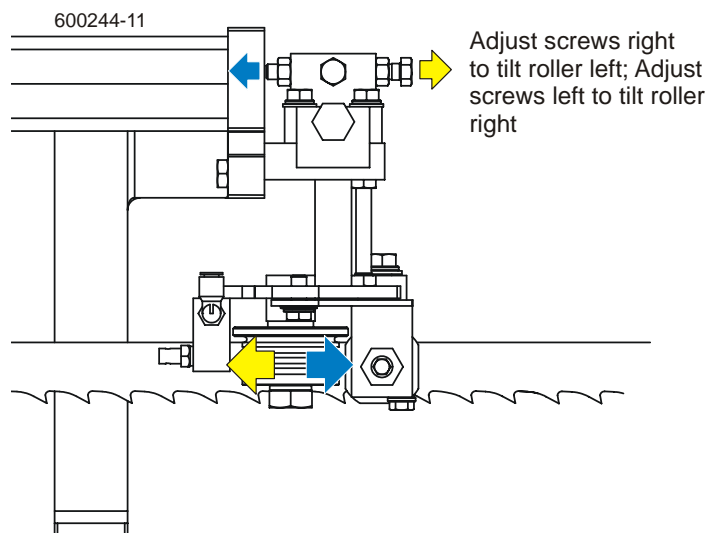

FIG. 7-39 REV. K1.01 - K3.02 (OPTIONAL HIGH-PERFORMANCE ROLLER/BLOCKS SHOWN)

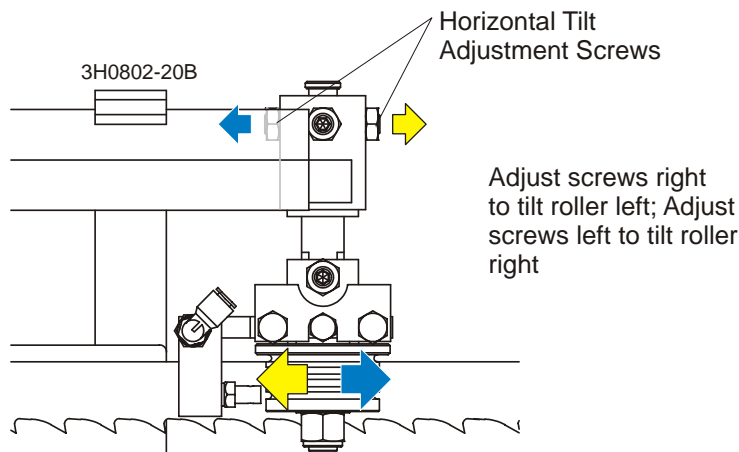

FIG. 7-39 PRIOR TO REV. K1.01

- Repeat the above steps for the inner blade guide roller assembly.

NOTE: Once the blade guides have been adjusted, any cutting variances are most likely caused by the blade. [See Blade Handbook, Form #600.](#)

- Check the blade guide blocks and drive side deflector plate are properly adjusted ([See Section 5.2](#)).

Blade Guide Flange Spacing

Each blade guide must be adjusted so the roller flange is the correct distance from the back edge of the blade. If the flange is too close to or too far from the blade, the sawmill will not cut accurately.

HINT: When adjusting blade guide spacing, loosen the top set screw and one side set screw only. This will ensure horizontal and vertical tilt adjustments are maintained when the adjustment screws are retightened.

1. Measure the distance between the flange on the outer blade guide roller to the back edge of the blade. This distance should measure 1/8" (3.0 mm). Adjust the roller back or forward if necessary.

See Figure 7-40. Loosen the top and one side screw shown. Tap the blade guide forward or backward until properly positioned. Retighten the screws and jam nuts.

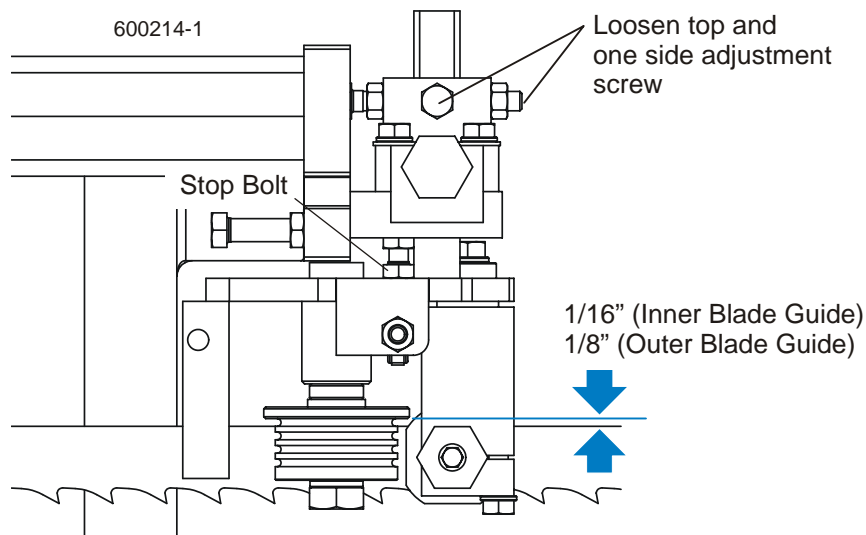

FIG. 7-40REV. K1.01 - K3.02 (OPTIONAL HIGH-PERFORMANCE ROLLER/BLOCKS SHOWN)

2. Measure the distance between the flange on the inner blade guide roller to the back edge of the blade. This distance should measure 1/16" (1.5 mm). Adjust the roller back or forward if necessary.



Sawmill Alignment

Complete Alignment Procedure

Blade Guide Level (Optional High-Performance blocks only)

Perform the following adjustments to make sure the blade guide assembly is parallel to the blade.

1. Loosen the alignment bar mounting bolt. Use the provided bottom block adjustment tool to adjust the alignment bar up so the bar is close to, but not touching the bottom of the blade. Retighten the alignment bar mounting bolt
2. Check that the gap from the alignment bar to the blade is the same along entire length of the bar. Shine a flashlight behind the blade guide assembly to help you see the gap between the bar and the blade.

Blade Block Adjustment (Optional High-Performance blocks only)

1. Remove the blade and remove the alignment bars from the blade guide assemblies. Install new or reconditioned bottom guide blocks to both blade guide assemblies (leave mounting bolts loose). Use the provided bottom block adjustment tool to lower the bottom block all the way down. Install, tension and track the blade.

See Figure 7-41.

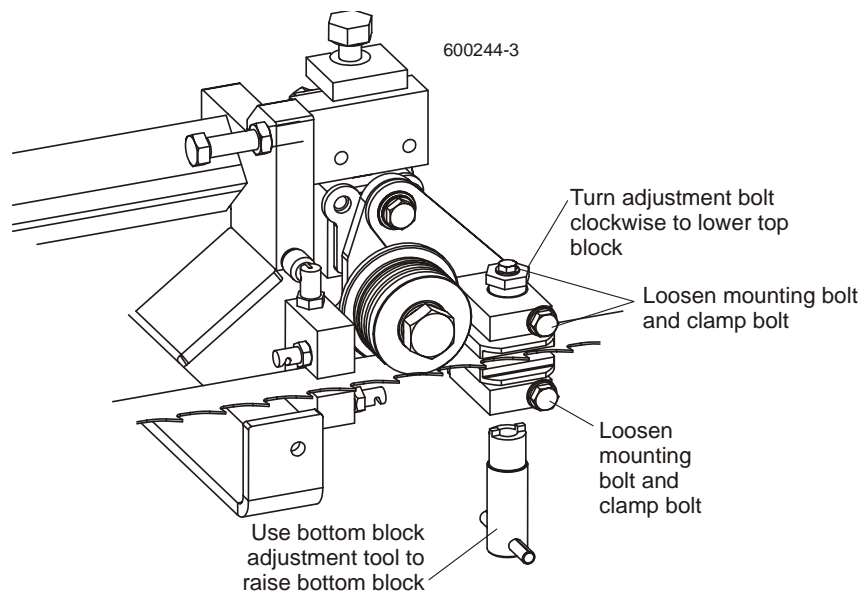

FIG. 7-41

2. Use the bottom block adjustment tool to raise the bottom block to .008" - .010" from the blade. Use the provided shim to set the distance from the block to the blade. Tighten the bottom block mounting bolt and clamp bolt.
3. Turn the top block adjustment bolt clockwise to lower the top block to .008" - .010" from the blade (using the shim as a guide). Tighten the top block mounting bolt and clamp bolt.
4. After tightening the clamp bolt, recheck the distance from the top block to the blade and readjust if necessary.

7 Sawmill Alignment

Complete Alignment Procedure

Side Support Alignment

Logs and boards are clamped against the side supports when sawing. The side supports must be square to the bed to ensure square lumber.

1. Swing a side support down and measure between the face of the support and the main bed tube. The distance at the top of the side support ('B') should be equal to or no more than 1/32" (0.8 mm) greater than the distance at the base of the side support ('A'). Adjust the horizontal tilt of the side support if necessary.

See Figure 7-42. Loosen the two adjustment plate mounting bolts. Use a mallet to move the plate until the side support is parallel to the bed tube in the horizontal position. Retighten the mounting bolts.

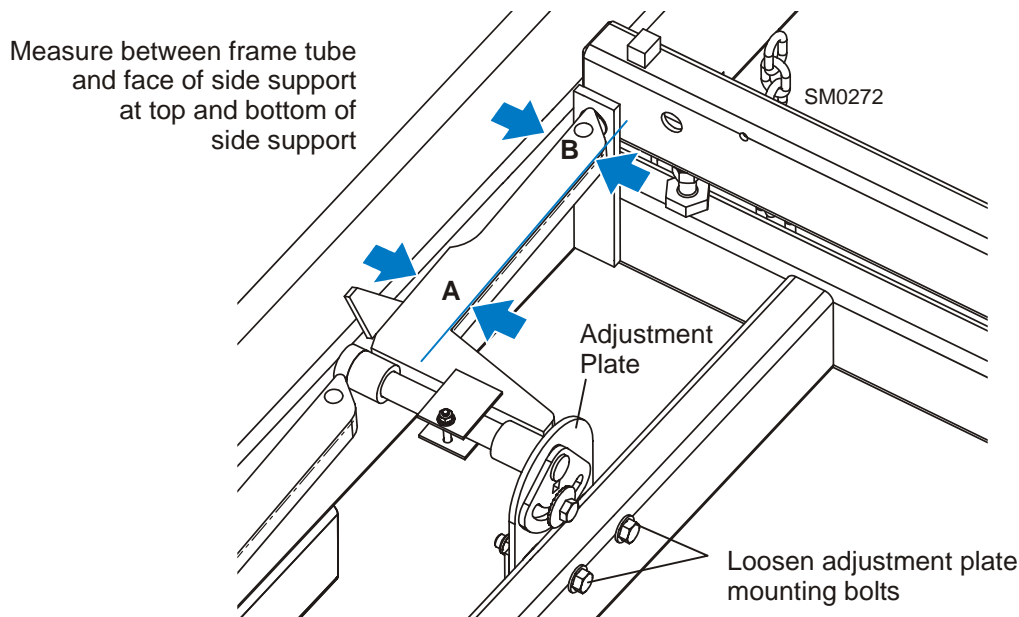

FIG. 7-42

2. Repeat the horizontal check for the remaining side supports. Adjust as necessary.
3. Place square alignment tubes (Part No. S12831 - 2 required) across the bed rails. Swing a side support up so that it is vertical.
4. Pull back at the top of the support to eliminate slack as if a log were being clamped against it.
5. Place a square against the face of the side support. The side support should be square or slightly tilted forward 1/32" (0.8 mm). Adjust the vertical tilt of the side support if necessary.

See **Figure 7-43**. Loosen the side support mounting bolt. Use a 3/8" ratchet to rotate the pin until the side support is square to the bed.

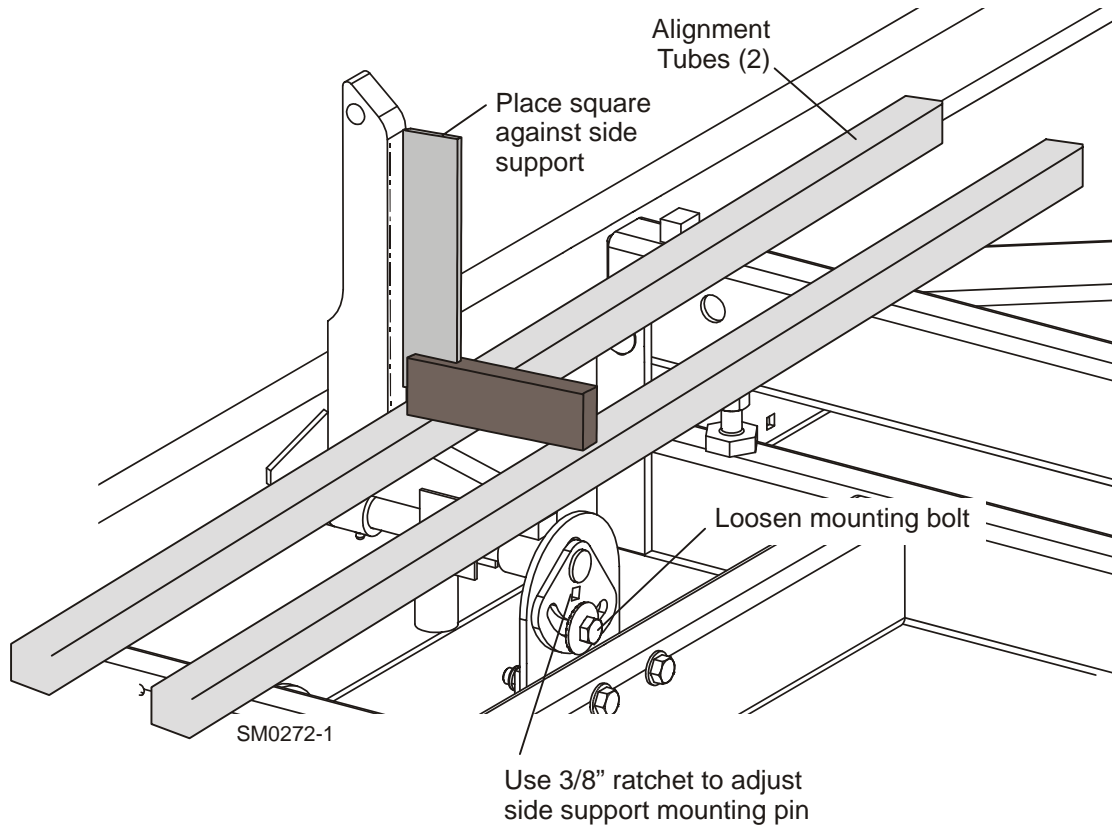

FIG. 7-43

6. Repeat the vertical check for the remaining side supports and adjust as necessary.

7 Sawmill Alignment

Complete Alignment Procedure

Clamp Stop/Stop Bolt Adjustment

1. Once the side supports are aligned, pivot them down to their horizontal position.
2. Tie a string to the stop block at the first bed rail. Stretch the string toward the rear of the frame and tie to the stop block at the last bed rail.

See Figure 7-44. Loosen the clamp stop bolts and adjust the clamp stop until it touches the string. Loosen the jam nut and adjust the bolt on the middle-rear bed rail until it touches the string.

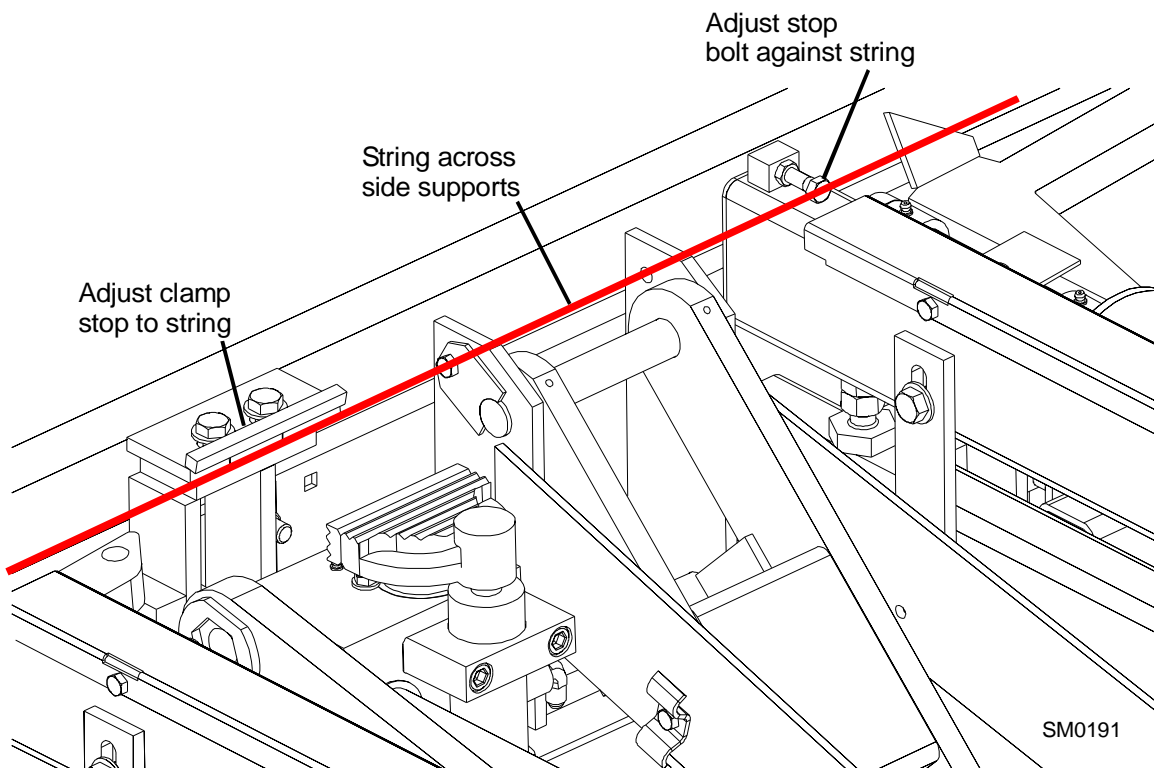

FIG. 7-44

Saw Head Tilt

As the blade enters a wide log or cant, the outside of the saw head will drop down slightly. To compensate for the drop, the saw head is adjusted $1/16"$ (1.5 mm) higher at the outside.

1. Move the saw carriage so the blade is positioned over a bed rail. Adjust the blade guide arm to $1/2"$ (15 mm) from full open. The saw head should still be adjusted so the blade is $14\ 3/4"$ (375 mm) above the bed rails.

See Figure 7-45.

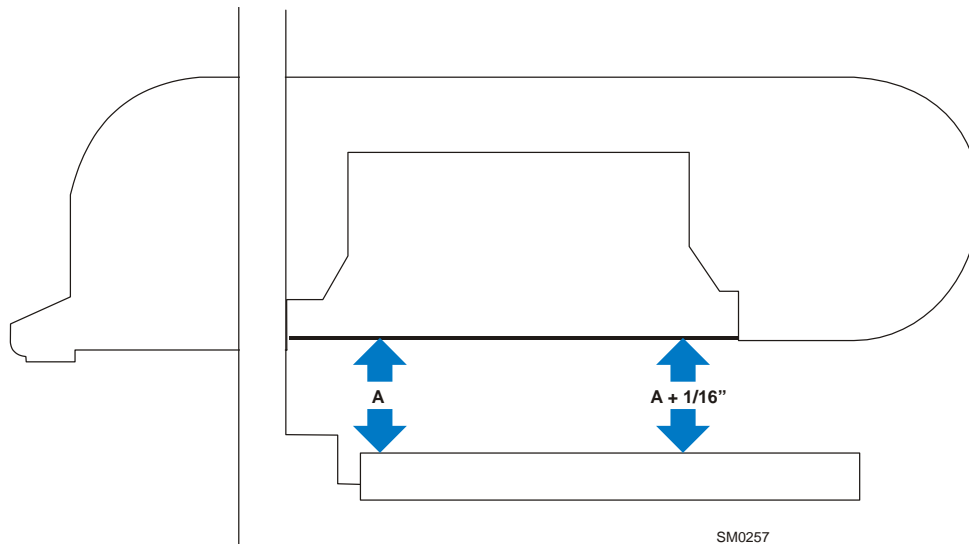

FIG. 7-45

2. Measure from the blade to the bed rail near the outer blade guide assembly. This measurement should be $1/16"$ (1.5 mm) higher than the inner measurement.

7 Sawmill Alignment

Complete Alignment Procedure

See Figure 7-46. To adjust the saw head tilt, use the horizontal adjustment nuts. To raise the outside of the saw head, loosen the four inner adjustment nuts 1/4 turn and tighten the four outer nuts. Recheck the measurement from the blade to the bed rails and adjust the horizontal adjustment nuts until the outside of the saw head is 1/16" higher than the inside.

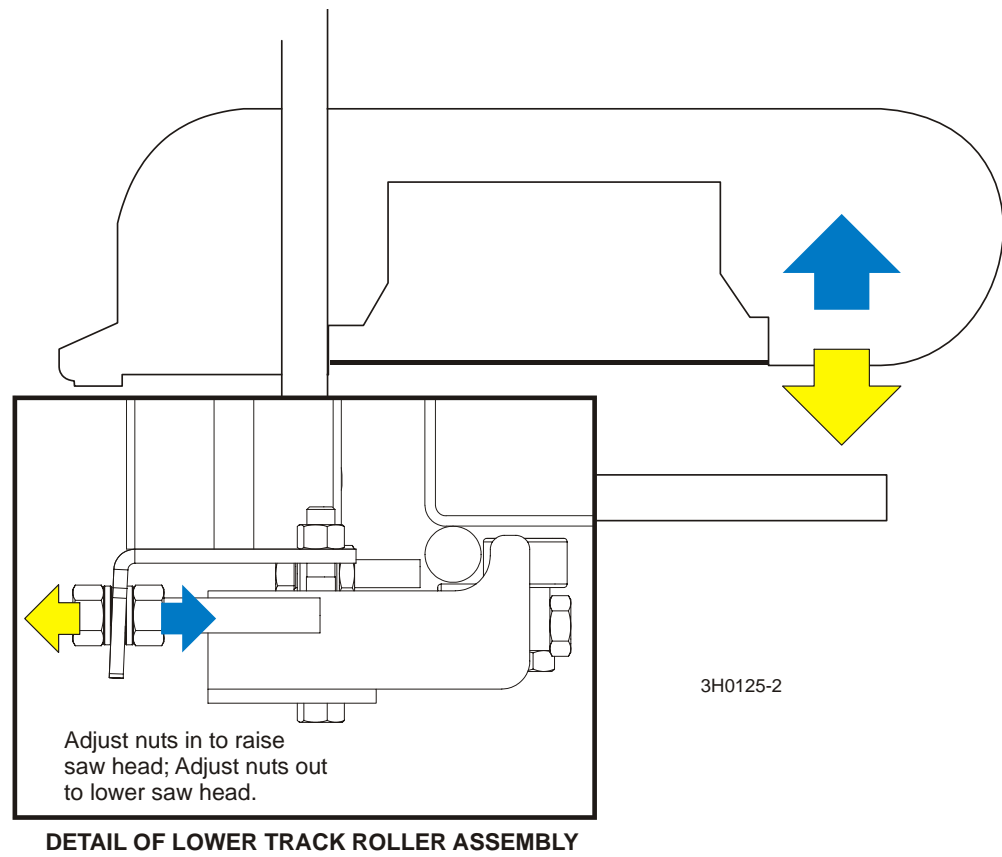

FIG. 7-46

Blade Height Scale Adjustment

After the entire sawmill has been aligned and all adjustments made, check that the blade height scale indicates the true distance from the blade to the bed rails.

1. Move the saw carriage so the blade is positioned directly above one of the bed rails. Measure from the bottom edge on a down-set tooth of the blade to the top of the bed rail, near the inner blade guide assembly.
2. View the blade height scale with eyes level with the indicator. The scale should indicate the actual distance from the blade to the bed rail. Adjust the indicator if necessary.

See Figure 7-47. Loosen the indicator bracket mounting bolts. Adjust the bracket up or down until the indicator is aligned with the correct mark on the scale (+0 -1/32 [0.8 mm]). Retighten the bracket mounting bolts.

For example, if the measurement from the down-set tooth of the blade to the bed rail was 14 3/4" (375 mm), make sure the indicator reads 14 3/4" (375 mm) on the scale.

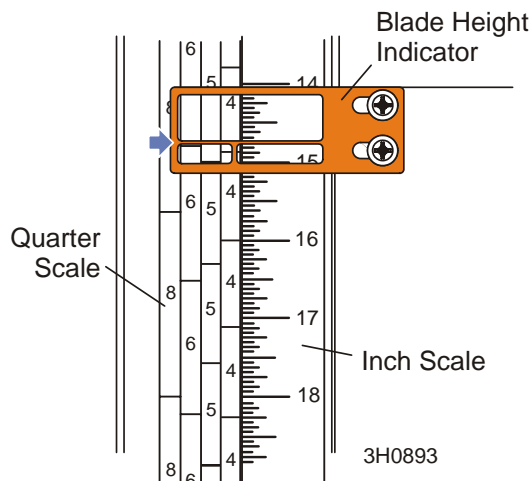

FIG. 7-47

7 Sawmill Alignment

Complete Alignment Procedure

Board Return Bracket

Adjust the board return bracket so the bottom edge is positioned 1/4" below the bottom of the blade.

1. With a square cant on the bed rails, lower the blade until it touches the top of the cant. Then raise the saw head 1/4" as shown on the scale.
2. Lower the board return arm. The board return bracket should barely touch the top of the cant.
3. Loosen the three bracket mounting bolts to adjust the bracket up or down as necessary.

See Figure 7-48.

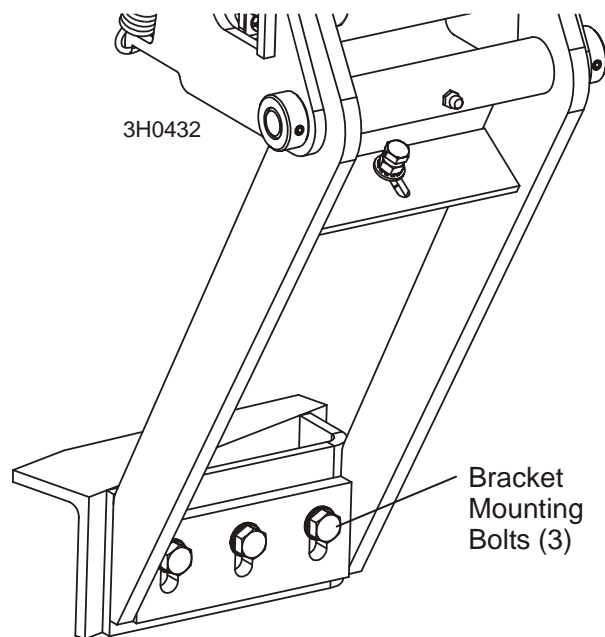

FIG. 7-48

SECTION 8 HYDRAULIC INFORMATION

8.1 Hydraulic Schematic

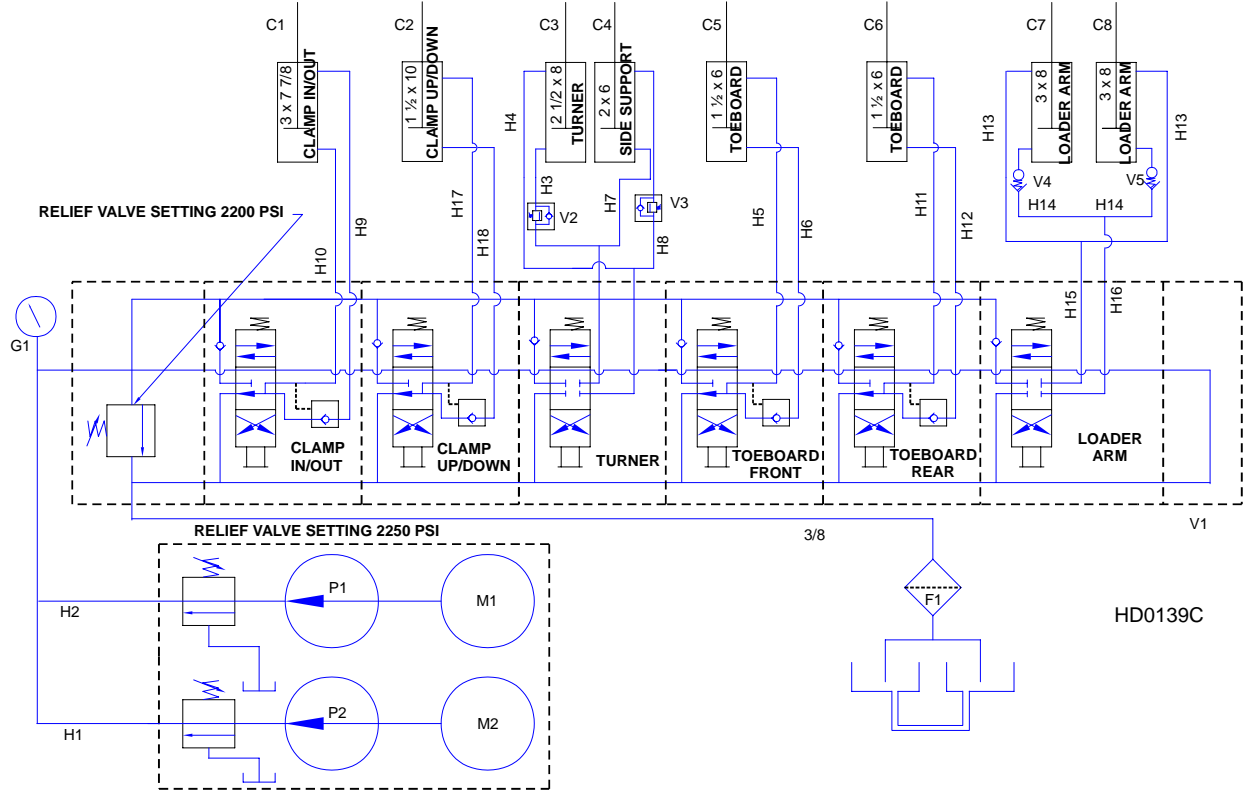

FIG. 8-1 HYDRAULIC SCHEMATIC.

8.2 Hydraulic Layout Diagram

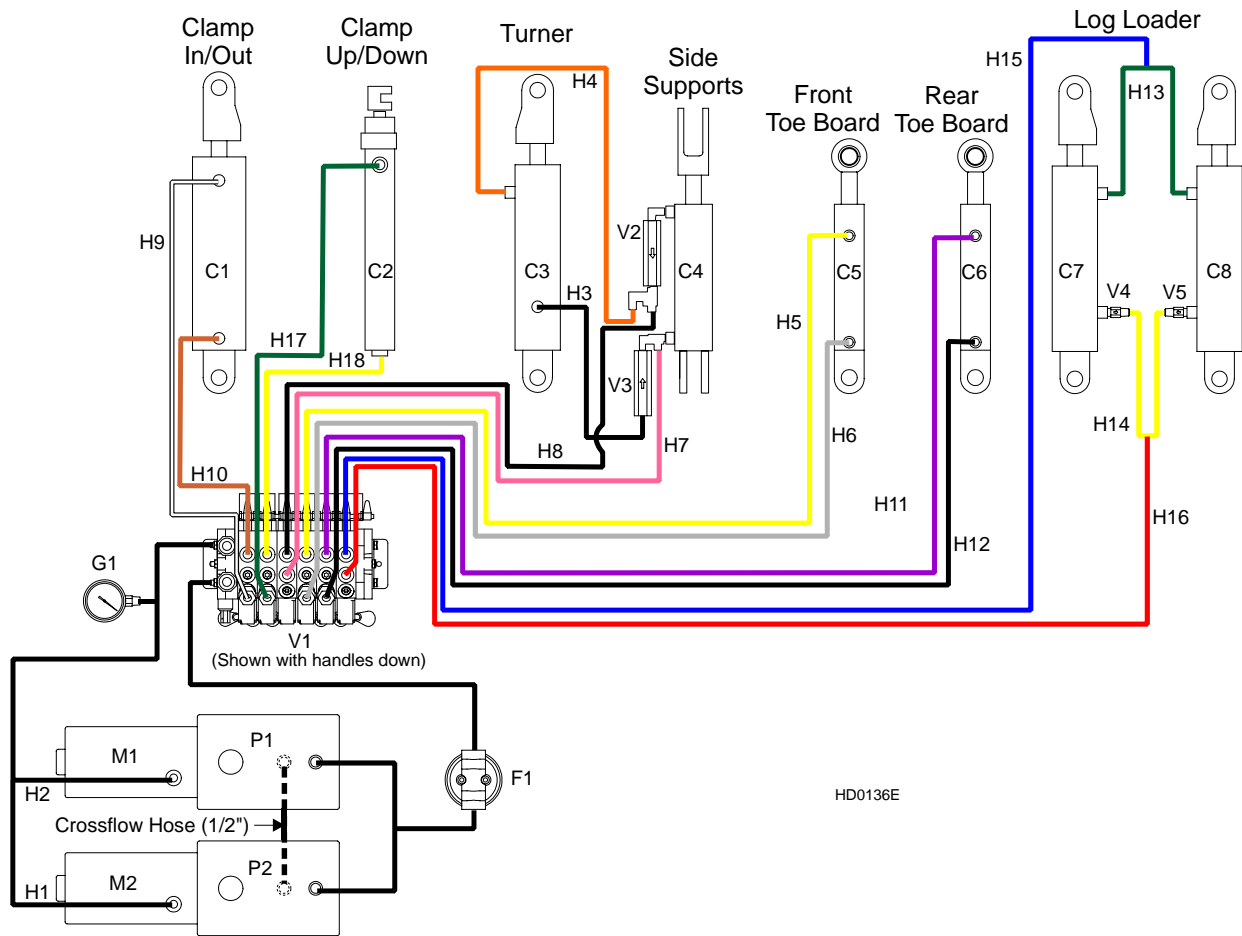

FIG. 8-2 HYDRAULIC LAYOUT DIAGRAM.

8.3 Hydraulic Components

ID	Mfg. Part No.	Manufacturer	Wood-Mizer Part #	Description
C1	017275	J-D Hydraulic	017275	Hyd. Cylinder, 3" Bore X 7" Stroke
C2	PMC-19410	Prince Mfg.	015050	Hyd. Cylinder, 1 1/2" Bore X 10" Stroke
C3	P12846	J-D Hydraulic	P12846	Hyd. Cylinder, 2 1/2" Bore X 8" Stroke
C4	P12845	J-D Hydraulic	P12845	Hyd. Cylinder, 2" Bore X 6" Stroke
C5, C6	014482	J-D Hydraulic	014482	Hyd. Cylinder, 1 1/2" Bore x 6" Stroke
C7, C8	P12847	J-D Hydraulic	P12847	Hyd. Cylinder, 3" Bore X 8" Stroke
P1, P2	M300-0230	Monarch Hyd.	P12701	Hydraulic Pump, With Motor
V1	HDS10/6-6	Betro Inc.	015260	Valve, 6-Handle
V2, V3	49004-700	Vonberg	015484	Sequence Valve
V4, V5	28000-502-5	Vonberg	015750	Valve, Hydraulic 5GPM Velocity Fuse
M1, M2	08058-I	Monarch Hyd.	052807 ¹	Motor, Iksra Hydraulic Pump
	08058	Monarch Hyd.	P09955 ¹	Motor, Bosch Hydraulic Pump
F1	S28	Hyd. Filter Supply	P20301	Filter, Hydraulic Fluid Cartridge
G1	CF-1P-210A	Pressure Devices Inc.	P10052	Gauge, 5000 PSI Hydraulic

TABLE 8-1

¹ Bosch motor P09955 replaced by vendor with Iksra motor 1/06. Brush kit P09585 no longer available to service Bosch motor. Replace motor using kit 052807 ([See Form #1578](#) for applicable discount information). Use Brush Kit 038682 to service Iksra motor.

8.4 Hydraulic Hoses

ID	Color Code	LENGTH "A"	Application	Wood-Mizer Part No.
H1	None	18"	1/4" Hydraulic Pump To Valve	015704
H2	None	18"	1/4" Hydraulic Pump To Valve	015704
H3	Plain	24"	3/8" Log Turner Base	014796
H4	Orange	18"	3/8" Log Turner Top	014795
H5	Yellow	95"	1/4" Front Toe Board Top (LT30HD Super)	P12540
		117"	1/4" Front Toe Board Top (LT40HD Super)	P12542
H6	Gray	95"	1/4" Front Toe Board Base (LT30HD Super)	P12540
		117"	1/4" Front Toe Board Base (LT40HD Super)	P12542
H7	Pink	156"	3/8" Side Support Base (LT30HD Super)	015686
		178"	3/8" Side Support Base (LT40HD Super)	015689
H8	Plain	156"	3/8" Side Support Top (LT30HD Super)	015686
		178"	3/8" Side Support Top (LT40HD Super)	015689
H9	White	128"	3/8" Clamp In/Out Top (LT30HD Super)	015683
		149"	3/8" Clamp In/Out Top (LT40HD Super)	015685
H10	Dark Orange	149"	3/8" Clamp In/Out Base (LT30HD Super)	015685
		171"	3/8" Clamp In/Out Base (LT40HD Super)	015684
H11	Purple	196"	1/4" Rear Toe Board Top (LT30HD Super)	014791
		219"	1/4" Rear Toe Board Top (LT40HD Super)	018026
H12	Black	196"	1/4" Rear Toe Board Base (LT30HD Super)	014791
		219"	1/4" Rear Toe Board Base (LT40HD Super)	018026
H13	Green	62"	3/8" Loading Arm Branch Top	014797
H14	Yellow	64"	3/8" Loading Arm Branch Base	014798
H15	Blue	164"	3/8" Loading Arm Top (LT30HD Super)	015687
		187"	3/8" Loading Arm Top (LT40HD Super)	015690
H16	Red	164"	3/8" Loading Arm Bottom (LT30HD Super)	015687
		187"	3/8" Loading Arm Bottom (LT40HD Super)	015690
H17	Green	181"	1/4" Clamp Up/Down Top (LT30HD Super)	014788
		204"	1/4" Clamp Up/Down Top (LT40HD Super)	014792
H18	Yellow	173"	1/4" Clamp Up/Down Base (LT30HD Super)	P12549
		194"	1/4" Clamp Up/Down Base (LT40HD Super)	015692

TABLE 8-2

INDEX

A

- alignment
 - lower track rollers 7-28
 - main bed rails 7-31
 - slide pad adjustment 7-28

B

- battery
 - charging with fuse terminal extension 6-23
 - troubleshooting problems 6-4
- blade
 - breakage, troubleshooting 6-1
 - installation 3-7
 - tensioning 3-8
 - tracking 3-9
- blade guide arm
 - operation 4-8

C

- chain
 - feed tension 5-29
 - maintenance 5-11
 - up/down tension 5-23
- clamping logs 4-5
- clutch/brake lever
 - operation 4-9

H

- hydraulic
 - component list 8-3
 - control operation 4-1, 4-3
 - fluid level 5-20
 - hose list 8-4
 - layout diagram 8-2
 - schematic 8-1
 - troubleshooting problems 6-12

L

- leveling logs 4-6
- loading logs 4-3

M

- maintenance
 - blade guide 5-2
 - blade tensioner 5-13
 - blade wheel belts 5-14, 5-15
 - brake adjustment 5-16
 - brake strap 5-16
 - carriage track/wipers 5-6, 5-7
 - drive bearing 5-22
 - drive belt 5-17
 - drum switches 5-10
 - hydraulic system 5-20
 - mast rails 5-8, 5-9
 - miscellaneous 5-11
 - part wear life 5-1
 - power feed 5-28
 - sawdust removal 5-6
 - up/down 5-23

O

- operation
 - edging 4-15
 - sawing 4-13

P

power feed
 mechanical troubleshooting test 6-21
 operation 4-12
 preliminary troubleshooting test 6-20
 speed adjustment 4-11
 troubleshooting problems 6-5

S

safety
 instructions 2-2
 lockout procedure 2-13
 symbols 2-1

scale
 blade height operation 4-17
 inch height 4-17
 quarter inch 4-18

service information
 branch locations 1-3
 customer & sawmill ID 1-10
 general contact info 1-2

setup
 portable sawmill 3-3
 stationary sawmill 3-1

switch
 power feed & up/down maintenance 5-10

T

tensioner
 maintenance 5-13

troubleshooting 6-1
 electrical problems 6-3
 hydraulic problems 6-12
 power feed problems 6-5
 sawing problems 6-1

turning logs 4-5

U

up/down
 operation 4-7
 troubleshooting problems 6-3

W

water lube
 operation 4-19