

# D20 Engine

## Safety, Operation, Maintenance & Parts Manual

---

<b>1992 LT30</b>	<b>rev. C4+</b>
<b>1992 LT40</b>	<b>rev. C5+</b>
<b>1992 LT30HD</b>	<b>rev. C7+</b>
<b>1992 LT40HD</b>	<b>rev. C7+</b>

---



**Safety is our #1 concern!** Read and understand all safety information and instructions before operating, setting up or maintaining this machine.

*October 1994*

*Form #658*

# Table of Contents

# Section-Page

<b>SECTION 1</b>	<b>SAFETY &amp; GENERAL INFORMATION</b>	<b>1-1</b>
1.1	Refueling .....	1-1
1.2	Engine Operation.....	1-1
1.3	Battery Handling .....	1-2
1.4	General Information .....	1-3
<b>SECTION 2</b>	<b>OPERATION</b>	<b>2-1</b>
2.1	Starting The Engine.....	2-1
2.2	Troubleshooting.....	2-5
<b>SECTION 3</b>	<b>MAINTENANCE</b>	<b>3-1</b>
3.1	Oil-Bath Air Filter .....	3-2
3.2	Engine Oil & Filter.....	3-3
3.3	Air Cooling System .....	3-4
3.4	Fuel Filter .....	3-5
3.5	Battery .....	3-6
3.6	Alternator Belt.....	3-7
3.7	Drive Belt Adjustment.....	3-8
3.8	Miscellaneous Maintenance .....	3-10
3.9	RPM Adjustments .....	3-11
<b>SECTION 4</b>	<b>REPLACEMENT PARTS</b>	<b>4-1</b>
4.1	How To Use The Parts List .....	4-1
4.2	Sample Assembly .....	4-1
4.3	Fuel Tank Assembly.....	4-2
4.4	Engine Assembly.....	4-3
<b>SECTION 5</b>	<b>ELECTRICAL INFORMATION</b>	<b>5-1</b>
5.1	Electrical Symbol Diagram, LT30/LT40 D20.....	5-1
5.2	Electrical Symbol Diagram, LT30/LT40 D20s .....	5-2
5.3	Electrical Symbol Diagram, LT30HD/LT40HD D20 (Rev. E7 - F7)....	5-3
5.4	Electrical Symbol Diagram, LT30HD/LT40HD D20 (Rev. C7 - E6) ...	5-4
5.5	Electrical Symbol Diagram, LT30HD/LT40HD D20s (Rev. E7 - F7) ..	5-5
5.6	Electrical Symbol Diagram, LT30HD/LT40HD D20s (Rev. C7 - E6)..	5-6
5.7	Electrical Components, LT30/LT40 D20/D20s .....	5-7
5.8	Electrical Components, LT30HD/LT40HD D20/D20s (Rev. E7 - F7)..	5-8
5.9	Electrical Components, LT30HD/LT40HD D20/D20s (Rev. C7 - E6)	5-10
5.10	Battery Specifications, LT30/LT40/LT30HD/LT40HD D20/D20s.....	5-12
5.11	Wiring Diagram, LT30/LT40 D20 .....	5-13
5.12	Wiring Diagram, LT30/LT40 D20s .....	5-14
5.13	Wiring Diagram, LT30HD/LT40HD D20 .....	5-15
5.14	Wiring Diagram, LT30HD/LT40HD D20s .....	5-16

## SECTION 1 SAFETY & GENERAL INFORMATION



This symbol calls your attention to instructions concerning your personal safety. Be sure to observe and follow these instructions. This symbol accompanies a signal word. The word **DANGER** refers to hazards that can cause death or serious, irreversible personal injury. The word **WARNING** suggests a safety hazard that can cause personal injury. **CAUTION** refers to hazards that can cause damage to the equipment or property only.

Read all safety instructions before operating this equipment and observe all safety warnings! Read the manufacturer's operation manual and observe any additional safety warnings applicable to the specific make and model you have purchased.

### 1.1 Refueling



**WARNING!** Store gasoline away from sawdust and other flammable materials.

**WARNING!** Do not store diesel fuel near hot or burning materials.

**WARNING!** Do not smoke near diesel fuel storage tank or during refueling.

### 1.2 Engine Operation



**DANGER!** Do not operate engine in enclosed areas. Carbon Monoxide poisoning may occur.

**DANGER!** Do not operate engine without proper and operational spark arrester/muffler.

### 1.3 Battery Handling



**WARNING!** Batteries can explode when charging or boosting. Always wear eye protection.

**WARNING!** Keep cigarettes, flames or sparks away from battery.

**WARNING!** Charge the battery in a well-ventilated area. Do not attempt to charge a frozen battery.



**CAUTION!** Place a rag over battery vent holes when handling to avoid electrolyte squirting from holes.

## 1.4 General Information



**IMPORTANT!** Read the engine manual for instructions and safety precautions before operating the engine.

For use with the Wood-Mizer sawmill, a fuel pump and special throttle have been added to the original engine design. A solenoid also has been added to allow you to operate the run/stop lever with the key switch on the sawmill control panel.

See **Figure 1-1**. The main components of the diesel engine are shown.

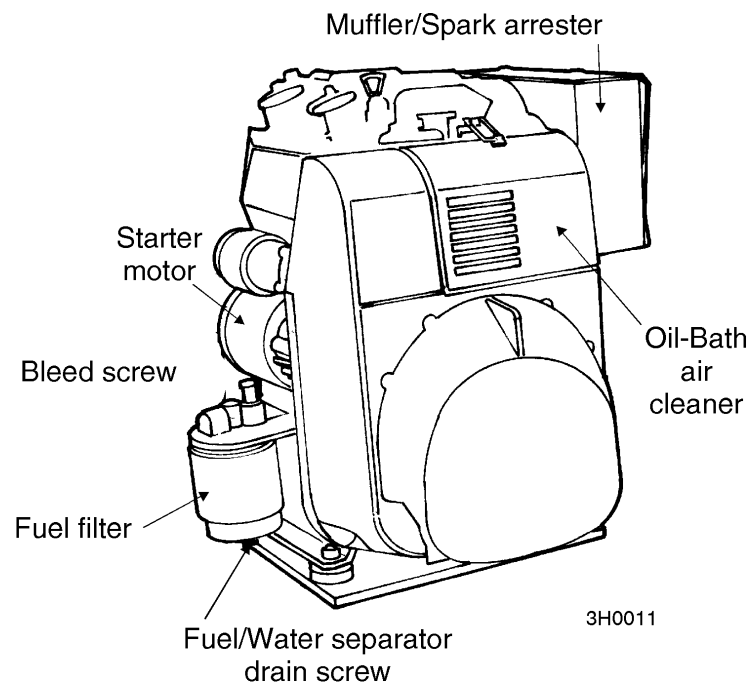

**FIG. 1-1**



## SECTION 2 OPERATION

### 2.1 Starting The Engine

To start the engine:

**During the initial break-in period (the first 100 hours of operation):** It is common for the engine to smoke when cold. To minimize smoking, begin cutting as soon as possible after starting. Avoid letting the engine idle for long periods of time (maximum 10 minutes) especially during break-in.



**IMPORTANT!** Be sure to change the oil and clean the oil filter, the oil filter receptacle, and the plug after the first 5 hours of operation and every 50 hours thereafter. Continue to check the oil level every 8 hours of operation and refill as necessary.

#### ***Above Freezing Starting***

1. See Acme owner's manual Lubricating Oil for specific temperature-range oil recommendations.
2. Use #2 or better quality diesel fuel.
3. Loosen the screw on the bottom of the fuel filter and drain until only fuel comes out. Retighten the screw.
4. Turn the key switch on the control panel to the START position and release.

***Below Freezing Starting***

1. See Acme owner's manual Lubricating Oil for specific temperature-range oil recommendations. **NOTE:** Use of synthetic oils, such as Mobil 1 Delvac, can aid cold starting.
2. Use #1 quality diesel fuel.
3. Loosen the screw on the bottom of the fuel filter and drain until only fuel comes out. Retighten the screw.
4. Remove the rubber plugs from the prestart holes. See Acme owner's manual *Cold Starting* Figures 6 and 7 for location. Insert approximately 3 cc (1/2 teaspoon) of oil into the holes. Use the same type of oil used in the engine. (See Acme owner's manual Lubricating Oil for oil recommendations.) Reinsert the rubber plugs. **NOTE: THIS PROCEDURE MUST BE REPEATED EACH TIME THE ENGINE FIRES BUT FAILS TO CONTINUE RUNNING.**
5. Hold the throttle lever (accelerator lever) at the 1/2 position to insure fuel flow to the injectors. Turn the key switch on the control panel to the START position and release. As soon as the engine starts, return the throttle lever to IDLE position.

**See Figure 2-1. NOTE:** Starting diesel sawmills below freezing may require the optional cold-weather starting kit. Contact our Customer Service hotline at **1-800-525-8100** for more information.



### **Rope Starting**

1. Open/remove the starting pulley cover.
2. Turn the key switch on the control panel to the ON position.

**See Figure 2-1.**

3. Push the run/stop solenoid in and release.
4. Rotate the starting pulley manually, in the opposite direction to that of its rotation, until you find strong resistance. Then, wind the rope up on the starting pulley and give the rope a determined pull in the engine rotation direction. **NOTE:** We have found rope starting successful in moderate weather. For starting in severe cold weather, see *Below Freezing Starting*.



**WARNING!** Do not start the engine when the clutch/brake lever is in the engaged (down) position. Always be sure the blade is disengaged and all persons are away from the blade before starting the engine.

**WARNING!** Make sure the carriage fwd/rev switch is in the neutral position before turning the key switch to the ON or ACC position. This will prevent unintended carriage movement.

**2** Operation  
*Starting The Engine*

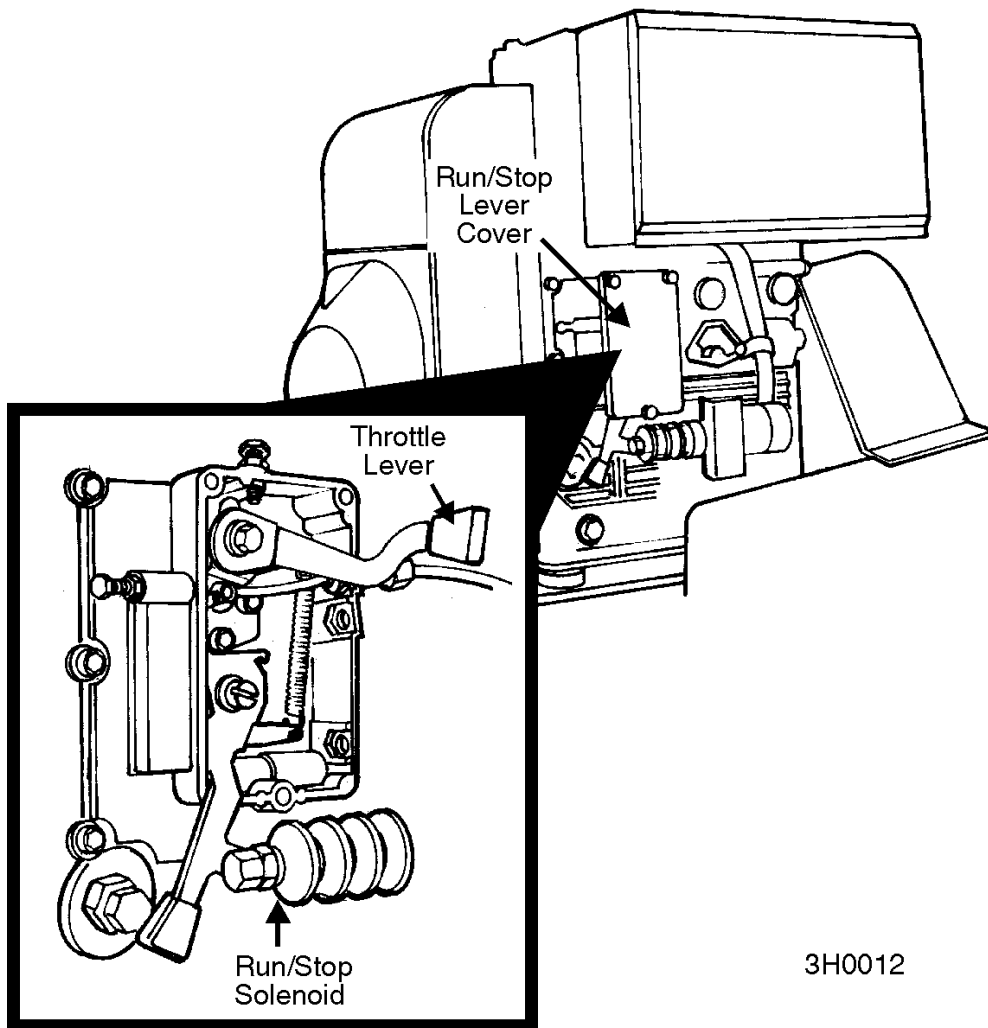

3H0012

**FIG. 2-1**

## 2.2 Troubleshooting

If the engine does not start or stops running:

1. Check the fuel level.
2. Make sure the fuel line is not pinched.
3. Check the condition of the battery and its connections.
4. Check the air filter. Clean if necessary.
5. Bleed the air from the fuel filter each time the engine runs completely out of fuel. Turn the bleed screw (located on the top side of the fuel filter, farthest away from the control box) counterclockwise to open it. When fuel appears, close the bleed screw by turning it clockwise.
6. Check for water in the fuel. Loosen the drain screw on the bottom of the fuel filter. Allow all fuel to drain into a can or pan. Water will appear as air bubbles at the bottom of the fuel. Retighten the drain screw. Bleed the air from the fuel filter (see above).
7. Check for faulty injector or clogged injector tip.
8. Check for clogged cooling fins on the cylinder and cylinder head. Also tighten any loose bolts on the cylinder head.



## SECTION 3 MAINTENANCE



**IMPORTANT!** The Wood-Mizer maintenance schedule takes into account the specific use of engines in the Wood-Mizer sawmill. Therefore, the schedule may require certain procedures be performed at different time intervals than found in the engine manufacturer's manuals. Refer to the manufacturer's manual if you need more information on how to perform a procedure or on the engine itself.



**This symbol** identifies the interval (hours of operation) which each maintenance procedure should be performed. "AR" signifies maintenance procedures which should be performed as required.

### 3.1 Oil-Bath Air Filter



Clean the oil-bath air filter every 8 hours of operation.

1. Disassemble the lower part of the air filter. Remove the foam pre-cleaner and the metal filtering element. Plunge the filtering element in parts solvent or diesel fuel several times until clean.
2. Wash the foam pre-cleaner in water and detergent. Rinse thoroughly and squeeze out any excess water. Allow to dry. Then, work a few drops of SAE 30 engine oil into the pre-cleaner. Wring out any excess oil. Replace the pre-cleaner if torn.
3. Check the oil level of the oil-bath air filter. Refill if necessary. If oil contains any impurities (sawdust or dirt, etc.), discard the oil, wash the oil holder and refill with clean oil. See engine manual for oil type recommendations.
4. Reinstall the metal filter element and the foam pre-cleaner over the bottom part of the oil-bath air filter. Reassemble the oil-bath air filter.
5. Also, clean the cyclonic filter at the side of the oil-bath air filter. Remove the wing nut and screw to disassemble the cyclonic filter. Clean all sawdust and dirt from it. Reassemble the cyclonic filter and secure to the oil-bath air filter with the wing nut and screw.

## 3.2 Engine Oil & Filter



Check the oil level every 8 hours of operation. Add oil as necessary. See the engine manual for oil viscosity and grade recommendations. Use Mobil Delvac 1 synthetic oil to aid starting in severe cold weather.



**IMPORTANT!** During initial break-in, change the oil and clean the oil filter after the first 5 hours and every 50 hours thereafter. Continue to check oil level every 8 hours of operation and refill as necessary.



Before reinstalling the clean oil filter, wipe all dirt and oil deposits from the oil filter receptacle.



Replace the oil filter every 500 hours.

### 3.3 Air Cooling System

50

Wash the engine or brush off sawdust and debris every 50 hours of operation. Clean the spark arresters, breather pipe, cylinder head and cylinder cooling fins. Remove any dust, dirt or oil. See engine manual for further instructions.



**CAUTION!** Failure to clean the cylinder head AND cylinder cooling fins can cause engine damage. Remove the cylinder cover to thoroughly clean the cooling fins. See engine manual for further instructions.



### 3.4 Fuel Filter

100

Drain the fuel filter every 100 hours of operation. Loosen the screw on the bottom of the fuel filter and allow all water to drain from the filter. Retighten the screw.

500

Replace the fuel filter every 500 hours of operation.

### 3.5 Battery

50

Check the battery electrolyte level every 50 hours of operation. See manufacturer's manual for instructions.



**WARNING!** Batteries contain explosive gases. Always wear eye protection and keep face away when charging or boosting battery. Charge battery in well-ventilated area. Keep battery away from hot or burning materials. Avoid spilling electrolyte when handling.

### 3.6 Alternator Belt

Adjust the alternator belt as needed. Check the alternator belt for tension and wear when battery is not charging properly or when the alternator belt is squealing. To tighten the belt, loosen the adjustment bolt and lock washer. Pivot the alternator away from the motor until the belt has 3/16" (5 mm) deflection with a 5 lb. deflection force. Retighten the adjustment bolt.

See Figure 3-1.

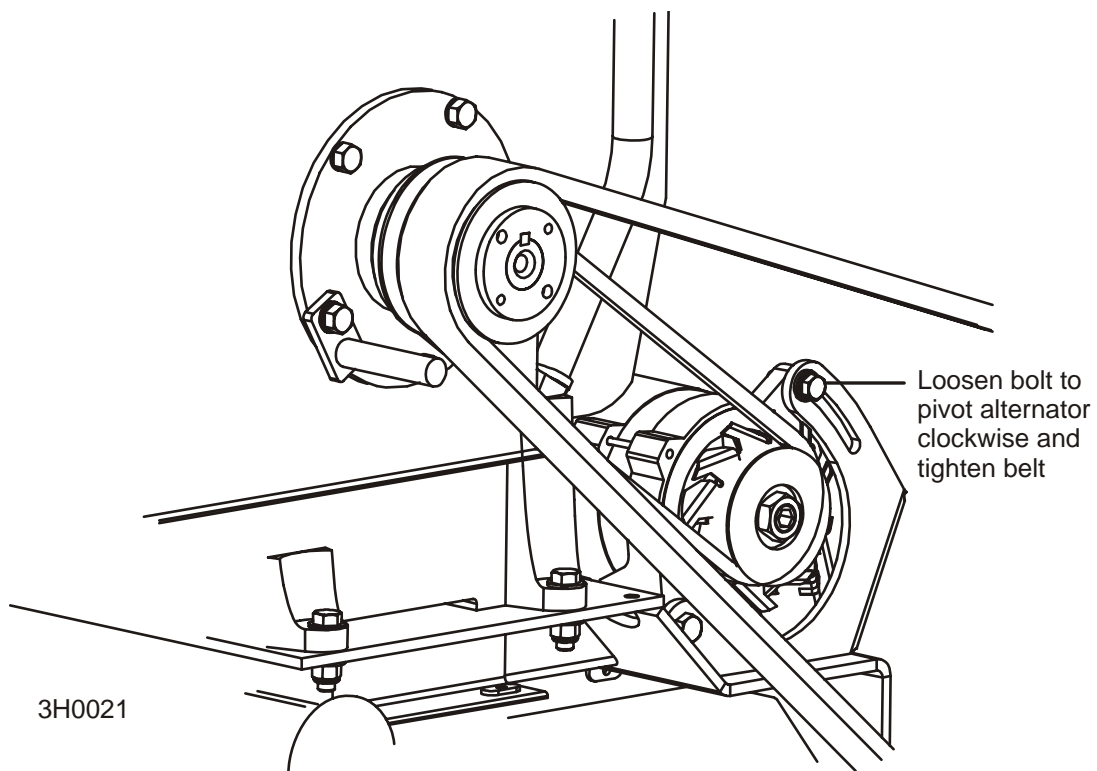

FIG. 3-1

### 3.7 Drive Belt Adjustment

50

**See Figure 3-2.** Check the drive belt tension after the first 20 hours, and every 50 hours thereafter. The drive belt should have 7/16" (11 mm) deflection with a 5 lb. deflection force. Always be sure to check the drive belt support after adjusting drive belt tension.

To adjust drive belt tension, remove the two belt covers located underneath the engine. Loosen the turnbuckle jam nuts. Turn the turnbuckle counterclockwise (as viewed from the top) to tighten the belts, clockwise to loosen the belts. Retighten the jam nuts. Replace the belt covers.

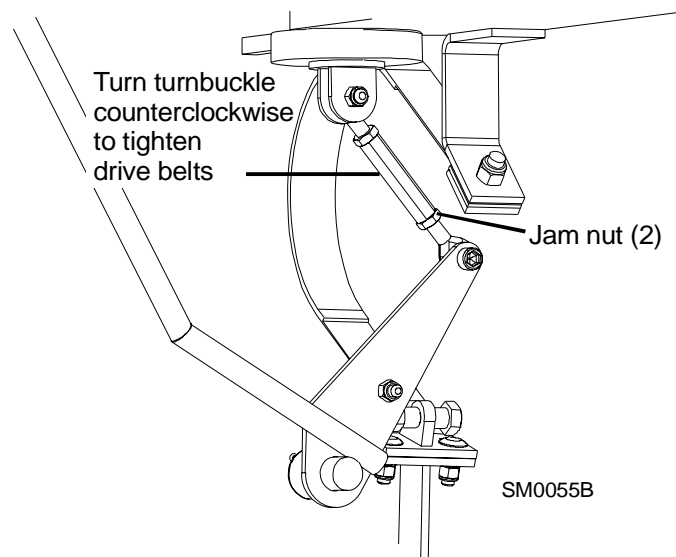

**FIG. 3-2**

AR

Periodically check all belts for wear. Replace any damaged or worn belts as needed.

AR

Adjust the drive belt support as needed. The drive belt support is designed to extend belt life. The spider bracket should be adjusted to NOT touch the drive belt when the clutch handle is engaged (down position), AND to hold the drive belt away from the engine pulley when the clutch handle is disengaged (up position).



**DANGER!** Do not for any reason adjust the drive belt support with the motor running. Always stop the motor before reaching or looking into the drive belt area.

**See Figure 3-3.** To adjust the drive belt support:

1. Make sure the motor is not running. Loosen the adjustment bolts.

2. Position the spider bracket so that the prongs are close to, but not touching, the drive belt with the clutch handle engaged. Prongs A and B should squeeze the drive belt just enough so the belt does not touch the motor pulley with the clutch handle disengaged.

With the blade clutch disengaged, start the motor. Check to see if the drive belt drags against the motor pulley. If the belt still touches the pulley, stop the motor and use a rubber mallet to bend the prongs so they squeeze the belt slightly more. Continue adjustments until the prongs do not touch the drive belt with the clutch handle engaged and the belt drags as little as possible on the motor pulley with the clutch handle disengaged.

3. Retighten the adjustment bolts.

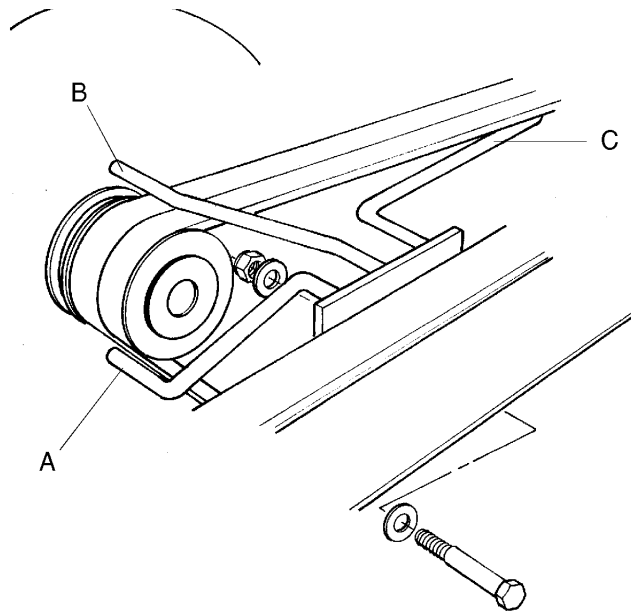

**FIG. 3-3**

**NOTE:** Drive belt support brackets are supplied on electric sawmills built after 1/92, gas and diesel sawmills after 9/92. The brackets can be retrofitted to older models. Replacing two drive belts with a single common-backed belt also will prevent belt jumping and increase belt life.

### 3.8 Miscellaneous Maintenance

50

Make sure all screws and bolts are tight every 50 hours of operation.

300

Tighten all fuel line fittings every 300 hours of operation



**CAUTION!** Over-tightening the fuel pipes (from the injection pumps to the injectors) will cause them to break!

300

Adjust the valve clearance every 300 hours of operation. See engine manual for further details.

### 3.9 RPM Adjustments



**DANGER!** Remove the blade from the sawmill before checking engine RPM.



Check the RPM with a tachometer after the first 20 hours of operation and every 200 hours thereafter. High-end RPM should be 3600-3700 RPM and low-end RPM should be 2050 ( $\pm 100$ ).

Before checking the RPM, make sure belt and brake strap tension are correct (See Sawmill Maintenance).

1. Start the engine to measure the low-end RPM.

**See Figure 3-4.** Make sure that the throttle linkage is not affecting the engine RPM while the clutch/brake handle is disengaged.

2. If the low-end RPM is too low, remove the run/stop lever cover. Loosen the low idle adjustment nut. Turn the adjustment screw in and retighten the adjustment nut.

If the low-end RPM is too high, back the low idle adjustment screw out. Locate the eye bolt at the end of the throttle cable and adjust it out until the throttle plate contacts the low idle screw.

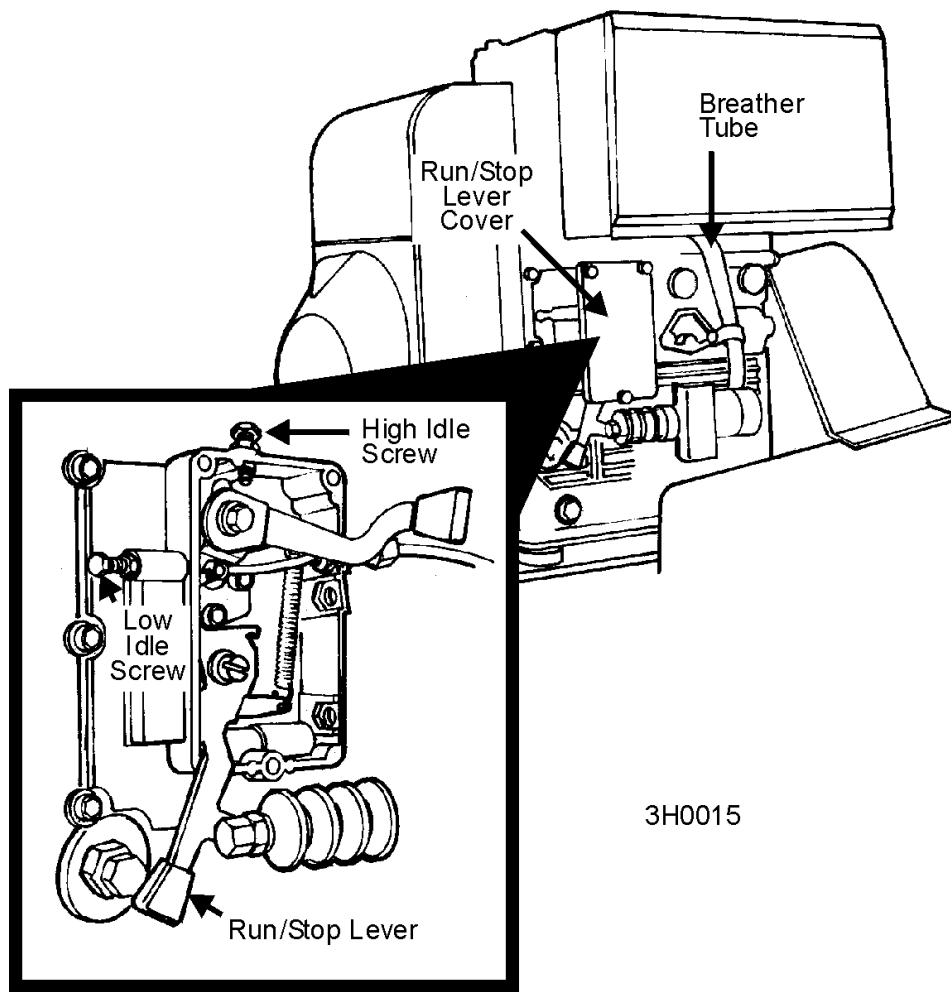
**FIG. 3-4**

3. Engage the clutch handle to throttle the engine and measure the high-end RPM.
4. If the high-end RPM is too high, remove the run/stop lever cover. Loosen the high idle adjustment nut. Turn the adjustment screw in and retighten the adjustment nut.

If the high-end RPM is too low, back the high idle adjustment screw out. Adjust the throttle cable where it enters the run/stop lever box until the throttle plate contacts the high idle screw.



## SECTION 4 REPLACEMENT PARTS

### 4.1 How To Use The Parts List

- Use the table of contents or the index to locate the assembly that contains the part you need.
- Go to the appropriate section and locate the part in the illustration.
- Use the number pointing to the part to locate the correct part number and description in the table.
- Parts shown indented under another part are included with that part.
- Parts marked with a diamond (◆) are only available in the assembly listed above the part.

See the sample table below. Sample Part #A01111 includes part F02222-2 and subassembly A03333. Subassembly A03333 includes part S04444-4 and subassembly K05555. The diamond (◆) indicates that S04444-4 is not available except in subassembly A03333. Subassembly K05555 includes parts M06666 and F07777-77. The diamond (◆) indicates M06666 is not available except in subassembly K05555.

<b>4.2 Sample Assembly</b>				
REF	DESCRIPTION (◆ Indicates Parts Available In Assemblies Only)	PART #	QTY.	
	<b>SAMPLE ASSEMBLY, COMPLETE (INCLUDES ALL INDENTED PARTS BELOW)</b>	A01111	1	
5	Sample Part	F02222-22	1	
	Sample Subassembly (Includes All Indented Parts Below)	A03333	1	
6	Sample Part (◆ Indicates Part Is Only Available With A03333)	S04444-4	1	◆
	Sample Subassembly (Includes All Indented Parts Below)	K05555	1	
7	Sample Part (◆ Indicates Part Is Only Available With K05555)	M06666	2	◆
8	Sample Part	F07777-77	1	

**To Order Parts:**

- From the continental U.S., call **1-800-525-8100** to order parts. Have your customer number, vehicle identification number, and part numbers ready when you call.
- From other international locations, contact the Wood-Mizer distributor in your area for parts.

# 4

## Replacement Parts

### Fuel Tank Assembly

#### 4.3 Fuel Tank Assembly

REF	DESCRIPTION (◆ Indicates Parts Available In Assemblies Only)	PART #	QTY.	
	<b>TANK ASSEMBLY, 5 GALLON GREEN DIESEL</b>	<a href="#">A12132</a> <sup>1</sup>	1	
1	Tank, 5 Gallon Green Fuel	P12166	1	◆
2	Pickup, 9" Fuel	<a href="#">P12172</a>	2	
3	Cap, 3/5 Gallon Fuel Tank	<a href="#">P09683</a>	1	
4	Fitting, 1/4" NPT Male Quick Disconnect	<a href="#">015583</a> <sup>1</sup>	1	
5	Fitting, Female Quick Disconnect Barb	<a href="#">015582</a> <sup>1</sup>	1	
6	Fitting, 1/4" NPT Plastic Female Disconnect	<a href="#">P12175</a> <sup>1</sup>	1	
7	Fitting, 1/4" NPT Plastic Male Return Line	<a href="#">P12173</a> <sup>1</sup>	1	
8	<b>HOSE, 1/4" ID FUEL</b>	<a href="#">P642</a> <sup>2</sup>	1	
9	<b>CLAMP, 7/32 - 1/2 HOSE</b>	<a href="#">P649</a> <sup>2</sup>	4	

<sup>1</sup> Tank assembly includes metal disconnect fittings 015582 and 015583 which replace plastic fittings p12174 and p12173 and metal fittings P07830 and P07831 originally supplied on fuel pickup line. Metal fittings require clamp P649.

<sup>2</sup> P642 fuel hose replaces R01890-1 originally supplied, Use clamp P649 with new hose (replaces 015584, P12374 and 016040 used with old fuel hose).

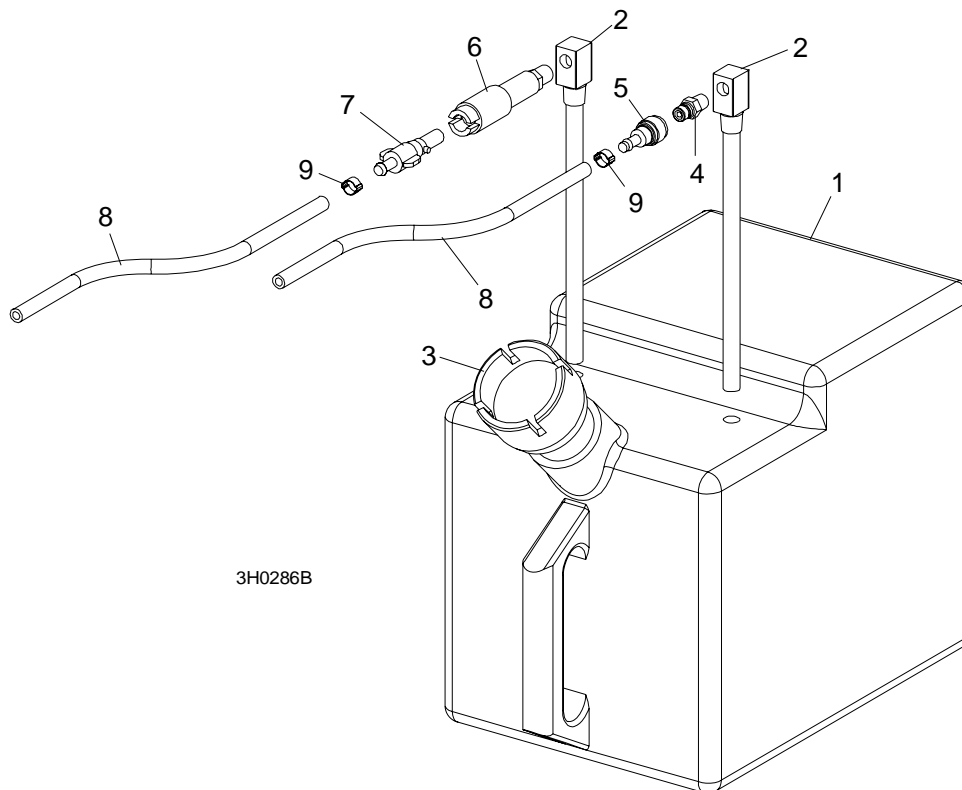

FIG. 4-1

<b>4.4 Engine Assembly</b>				
REF	DESCRIPTION (◆ Indicates Parts Available In Assemblies Only)	PART #	QTY.	
	<b>ENGINE ASSEMBLY, 20HP ACME DIESEL</b>	A12134 <sup>1</sup>	1	◆
1	Engine, 20hp Acme Model ADX740	P12133 <sup>2</sup>	1	◆
2	Pre-Cleaner, Acme 20hp Air #359.151	<a href="#">P12324</a>	1	
3	Filter, Acme 20hp Oil #175.005	<a href="#">P12178</a>	1	
4	Filter, Diesel Fuel #175.101	<a href="#">P12179</a>	1	
5	Muffler, 20hp Acme #B0123-S	<a href="#">P12190</a>	1	
6	Cable, Acme 20hp Throttle #182.5016	<a href="#">P12151</a>	1	
7	Solenoid, 20hp Diesel Run	<a href="#">P12136</a>	1	
	Oil, 10W30 Type CD	L04869-1	.5 GAL	◆
8	Pulley, 3-Groove Diesel Engine	<a href="#">S12140-W</a>	1	
9	Screw, 8mm X 1.25" X 12mm Socket Head Set	<a href="#">F05023-3</a>	1	
10	<b>BELT, 2BX68 DRIVE</b>	<a href="#">P12139-2</a> <sup>3</sup>	1	
11	<b>PLATE, MOTOR MOUNT LT30/40 DIESEL</b>	<a href="#">W12273</a> <sup>4</sup>	1	
	<b>BUSHING ASSEMBLY, MOTOR MOUNT PIVOT</b>	A04127 <sup>5</sup>	2	◆
12	Bushing, Rubber Motor Mount Pivot	<a href="#">P12164</a>	1	
13	Spacer, Motor Mount Pivot	<a href="#">P05041</a>	1	
14	<b>PLATE, MOTOR MOUNT PIVOT BUSHING</b>	<a href="#">S04403</a>	2	
15	<b>BOLT, 5/16-18 X 2 1/2" 'U'</b>	<a href="#">P05039</a>	2	
16	<b>NUT, 5/16-18 HEX LOCK</b>	<a href="#">F05010-6</a>	2	
17	<b>BOLT, 3/8-16 X 2 1/2" HEX HEAD GRADE 5</b>	<a href="#">F05007-47</a>	4	
18	<b>WASHER, 3/8" SAE FLAT</b>	<a href="#">F05011-3</a>	4	
19	<b>NUT, 3/8-16 HEX NYLON LOCK</b>	<a href="#">F05010-10</a>	4	
	<b>KIT, ALTERNATOR WITH BRACE</b>	<a href="#">K12801</a> <sup>4</sup>	1	
20	Alternator, 105A 12V	<a href="#">050287</a> <sup>4</sup>	1	
	Brace, Alternator	<a href="#">W12761</a> <sup>6</sup>	1	
	Bolt, 3/8-16 x 3 1/2" head head grade 8	<a href="#">F05007-6</a>	1	
21	Bolt, 3/8-16 x 5 1/2" hex head full thread	<a href="#">F05007-34</a>	1	
	Washer, 5/16" Split Lock	<a href="#">F05011-13</a>	1	
22	Nut, 3/8-16 Hex Nylon Lock	<a href="#">F05010-10</a>	1	
23	Bolt, M8 X 1.25" X 1" Hex Head Full Thread	<a href="#">F05004-40</a>	2	
	<b>WIRE ASSEMBLY, 61 AMP ALTERNATOR PLUG</b>	<a href="#">015969</a>	1	
24	<b>WASHER, 5/16" SAE FLAT</b>	<a href="#">F05011-17</a>	1	
25	<b>WASHER, 5/16" SPLIT LOCK</b>	<a href="#">F05011-13</a>	1	
26	<b>PULLEY, 1979452 DELCO ALTERNATOR</b>	<a href="#">P03806</a>	1	
27	<b>BELT, A30 ALTERNATOR</b>	<a href="#">P11628</a>	1	
	<b>BRACKET SUPPORT, DRIVE BELT 3-PRONG</b>	<a href="#">A12063</a> <sup>7</sup>	1	
28	Bracket, Drive Belt 3-Prong	W12050	1	◆
29	Bolt, 3/8-16 x 2 3/4" Hex Head	<a href="#">F05007-29</a>	2	
30	Washer, 3/8" SAE Flat	<a href="#">F05011-3</a>	4	

# 4

## Replacement Parts

### Engine Assembly

31	Nut, 3/8-16 Lock	<a href="#">F05010-10</a>	2	
	<b>OPTIONAL STARTING KIT, 20HP ACME COLD WEATHER</b>	<a href="#">K12326</a> <sup>8</sup>	1	
	Cover, Painted D20 Cold Weather Starting Fuse Box	S12345	1	◆
	Fitting, .75, LIQ TGHT	E20561	1	◆
	Conduit, 3/4" Maxiflex Black	<a href="#">R01624</a>	7	
	Wire, 4AWG Red Superflex	<a href="#">R01966</a>	10	
	Wire, 4AWG Black Superflex	<a href="#">R01968</a>	10	
	Terminal, 1/4" Ring 4GA NI Loose	F05092-25	2	◆
	Terminal, 5/16" Ring 4GA NI Loose	F05092-26	2	◆
	Tie Wrap, 1/2" x 10" Black	F05089-5	10	◆
	Tie Wrap, 3/16" x 8"	<a href="#">F05089-3</a>	5	
	Clamp, 2 1/2" Dia. Worm	P09895	2	◆
	Decal, 12V Power Supply Caution	<a href="#">P10364</a>	1	
	Decal, Hydraulic Fuse Links	S11949	1	◆
	Instruction Sheet, Cold-Weather Starting Kit	<a href="#">K12326-423</a>	1	
	<b>LEVER, THROTTLE ACME PART 492.206</b>	N/A <sup>9</sup>	1	

<sup>1</sup> Available 5/92.

<sup>2</sup> Engine made obsolete 3/98 (no longer manufactured).

<sup>3</sup> One double belt P12139-2 replaces two single belts P12139 (introduced LT30 Rev. D9, LT40 Rev. E1, LT30HD/LT40HD Rev. E3).

<sup>4</sup> 105A Alternator 050287 replaces 61A alternator P03804 originally supplied (no longer available from vendor). Requires replacement of mounting bracket (W12273). Existing brackets can be modified to accept 105A alternator by grinding enough material (approx. 1/16" - 1/8") from the bottom of the mounting plates to clear the larger alternator body.

<sup>5</sup> A04127 no longer available. Purchase individual component parts P12164 and P05041.

<sup>6</sup> Added to reinforce alternator (LT30 Rev. E5387, LT40 Rev. E6102, LT30HD Rev. E8329, LT40HD Rev. E8354).

<sup>7</sup> Replaces single-prong drive belt support A12063 which was assembled to mills LT30 Rev. D1-D9, LT40 Rev. D2-E1, LT30HD/LT40HD Rev. D5-E3. (LT30 Rev. E1, LT30 Rev. E2, LT30HD/LT40HD Rev. E4).

<sup>8</sup> Available 4/93.

<sup>9</sup> Added as a standard part on 20HP engines 4/93. Part may be ordered through Wood-Mizer at no charge to customer to assist engine in below-freezing starting.

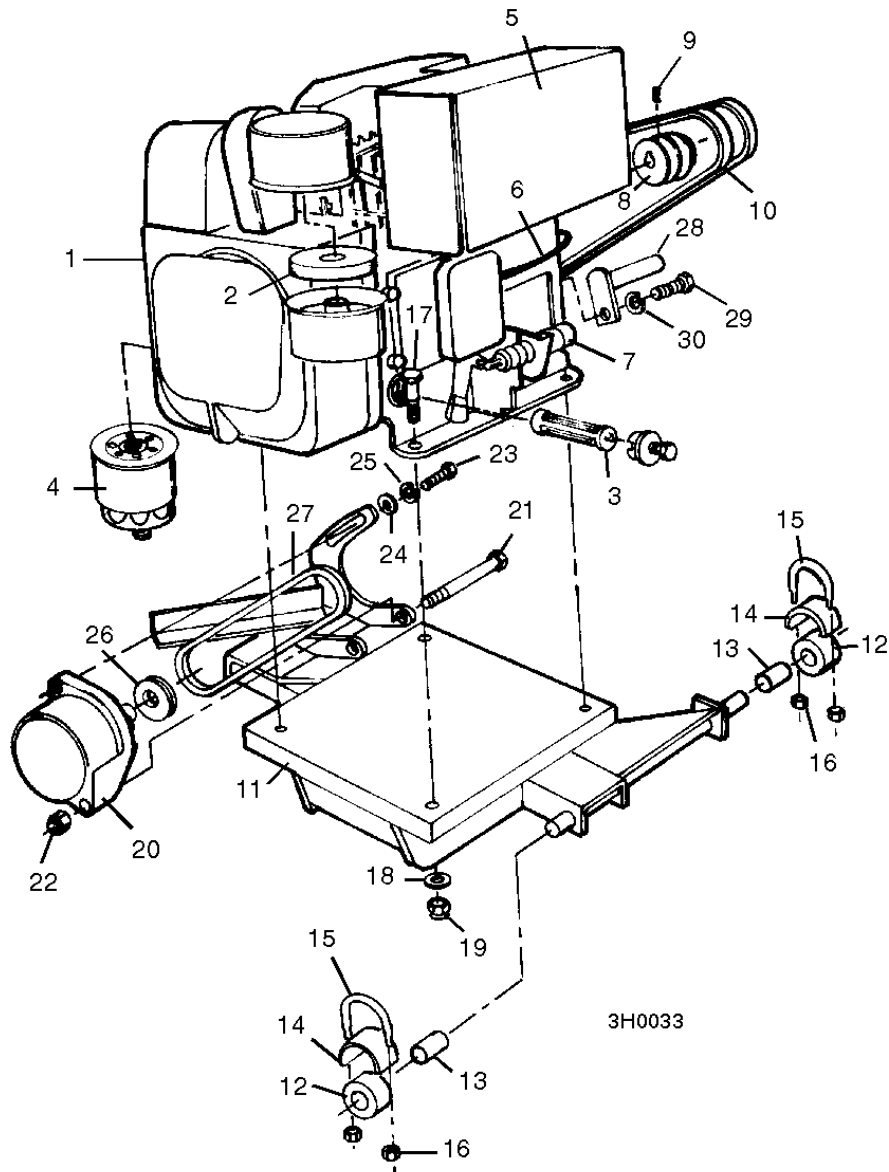



## SECTION 5 ELECTRICAL INFORMATION

### 5.1 Electrical Symbol Diagram, LT30/LT40 D20

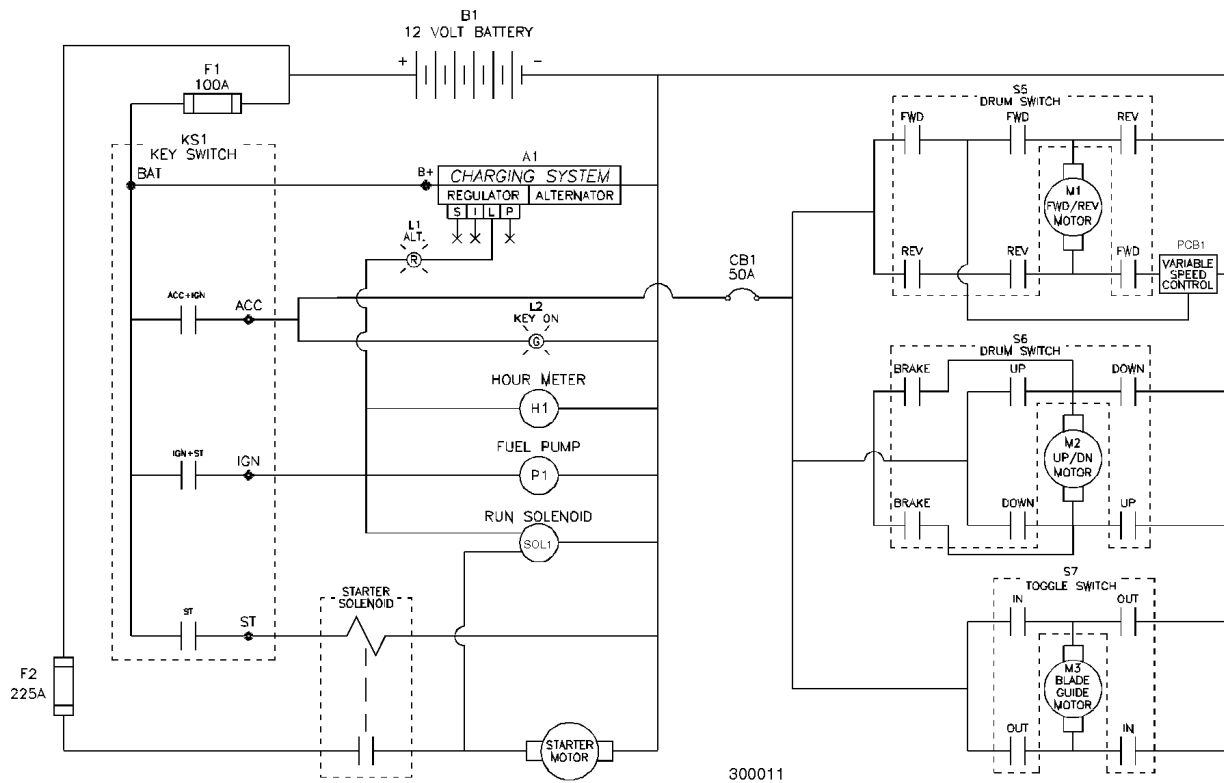
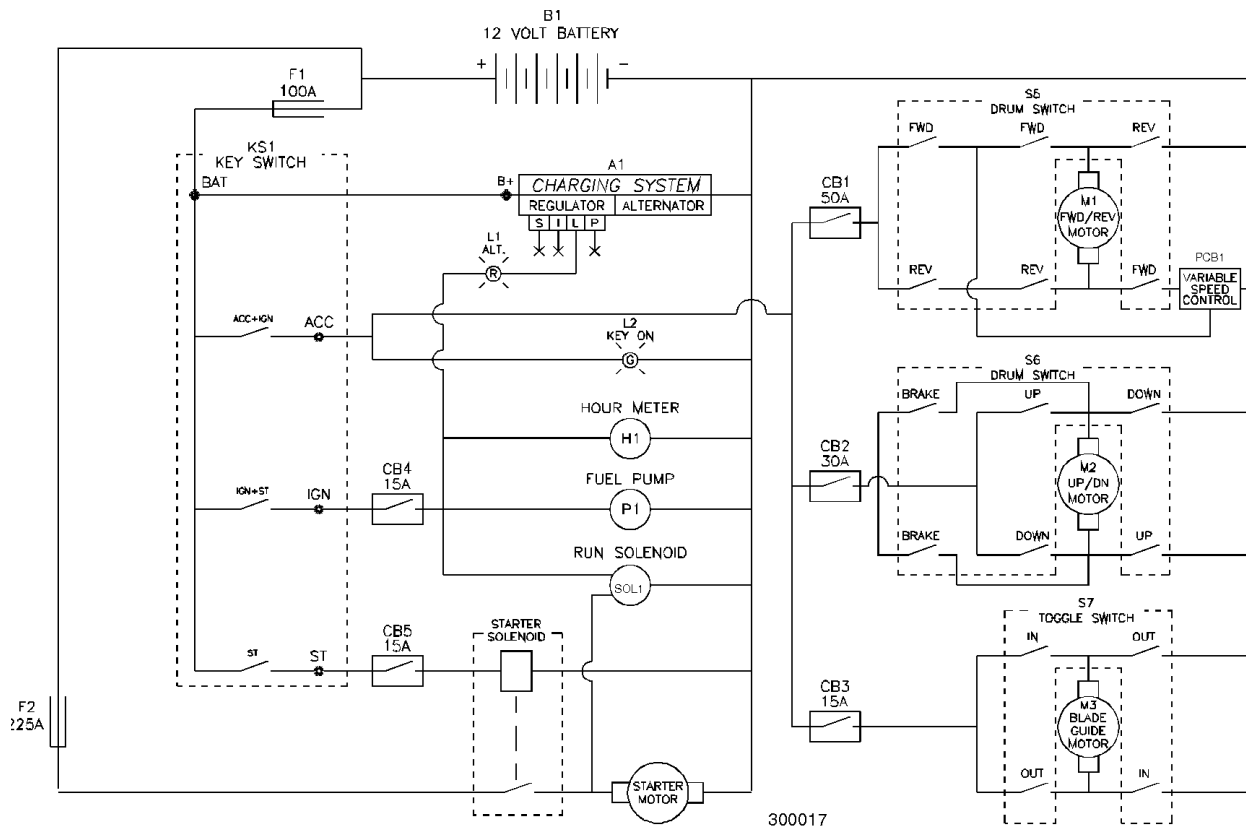

FIG. 5-1

**5.2 Electrical Symbol Diagram, LT30/LT40 D20s**



**FIG. 5-2**



5.3 Electrical Symbol Diagram, LT30HD/LT40HD D20 (Rev. E7 - F7)

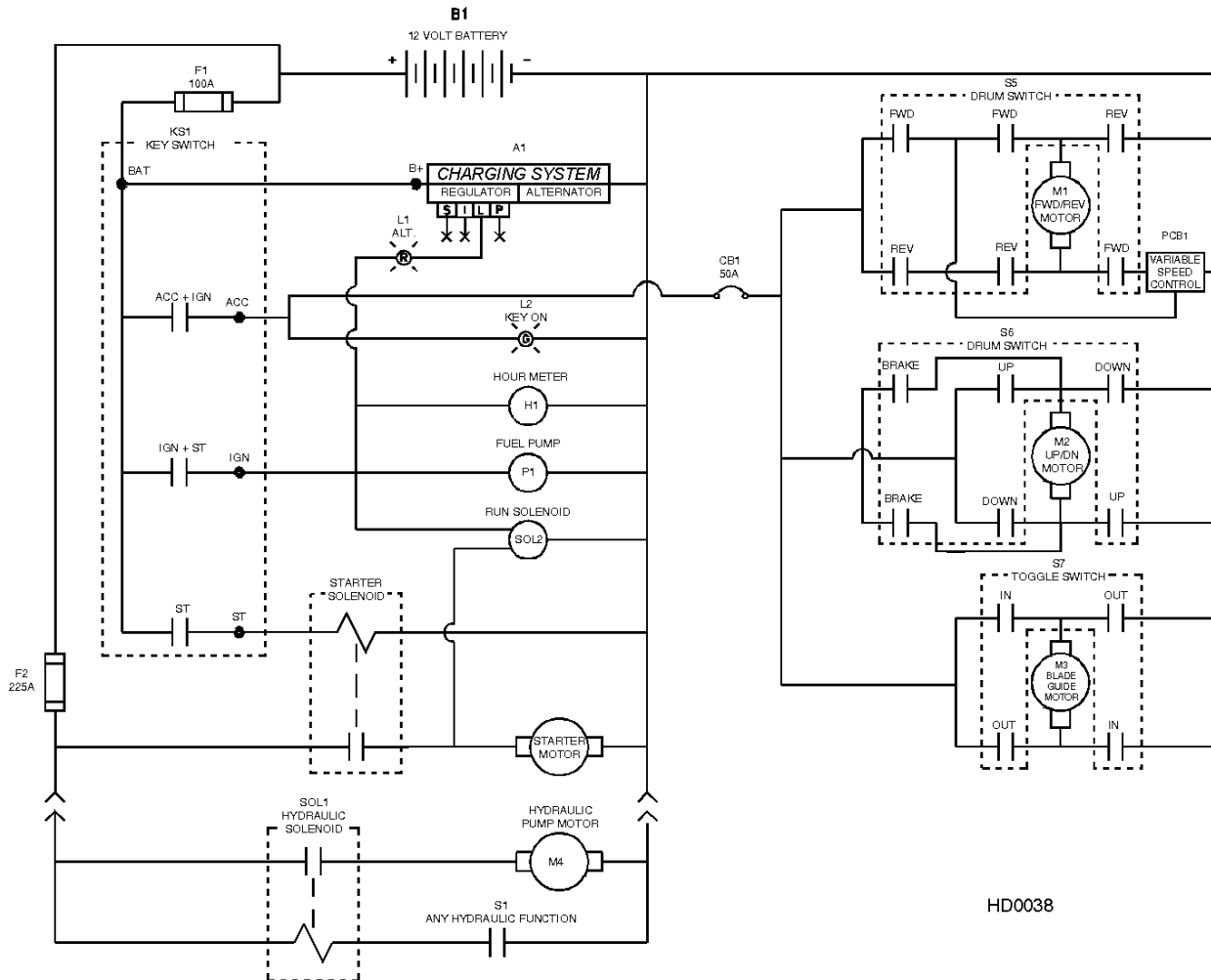

HD0038

FIG. 5-3

# 5 Electrical Information

Electrical Symbol Diagram, LT30HD/LT40HD D20 (Rev. C7 - E6)

## 5.4 Electrical Symbol Diagram, LT30HD/LT40HD D20 (Rev. C7 - E6)

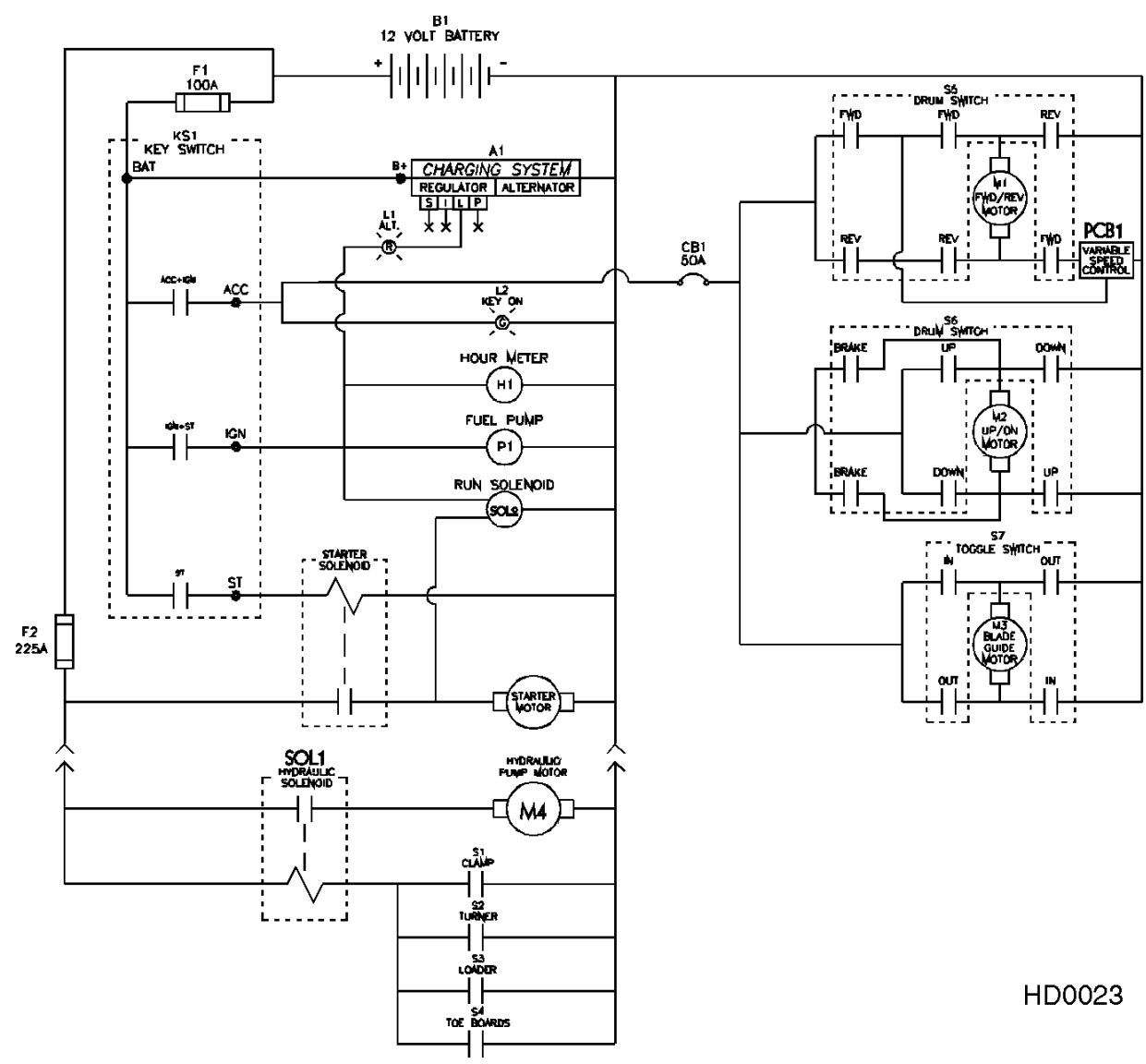

HD0023

FIG. 5-4

5.5 Electrical Symbol Diagram, LT30HD/LT40HD D20s (Rev. E7 - F7)

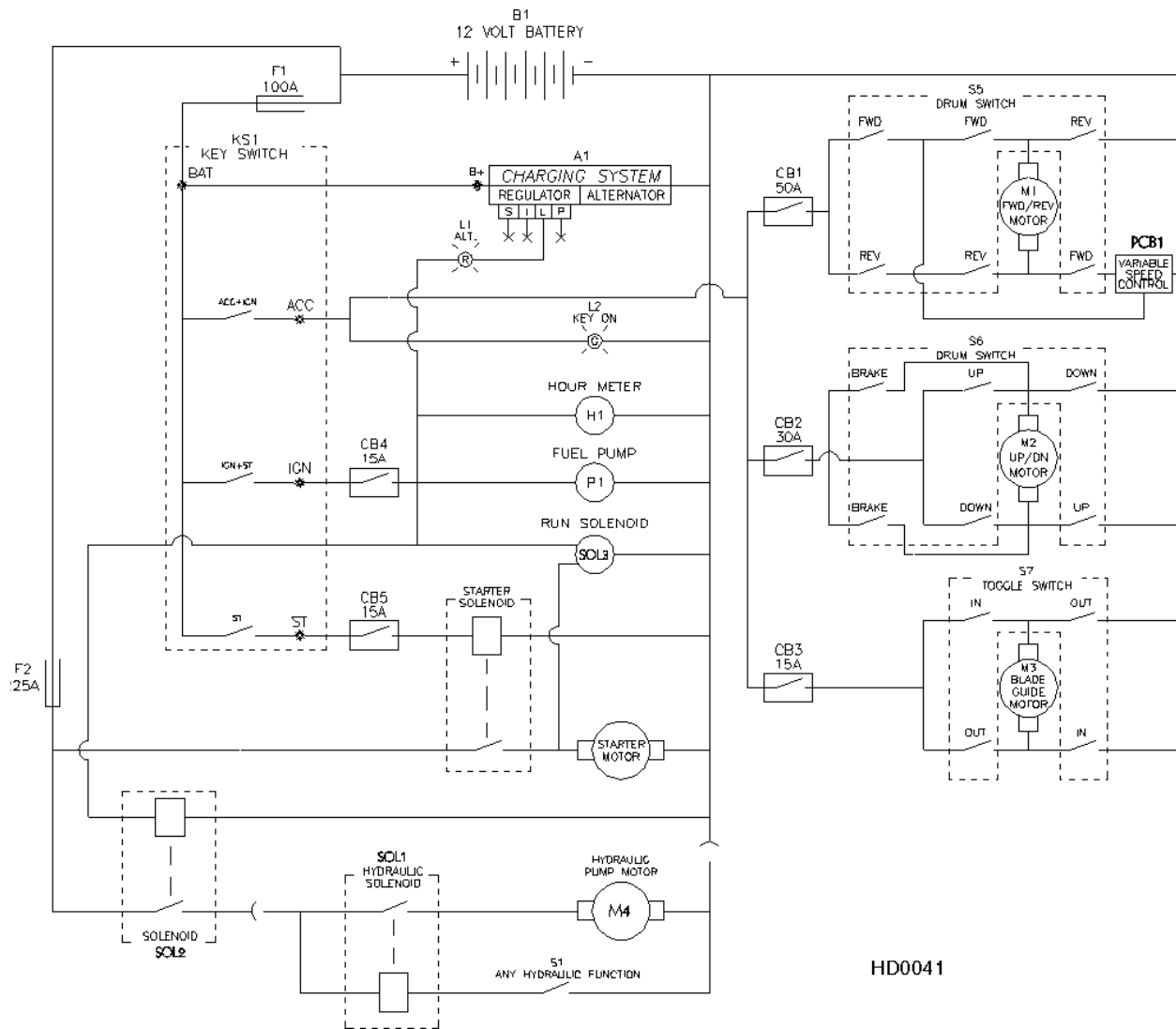
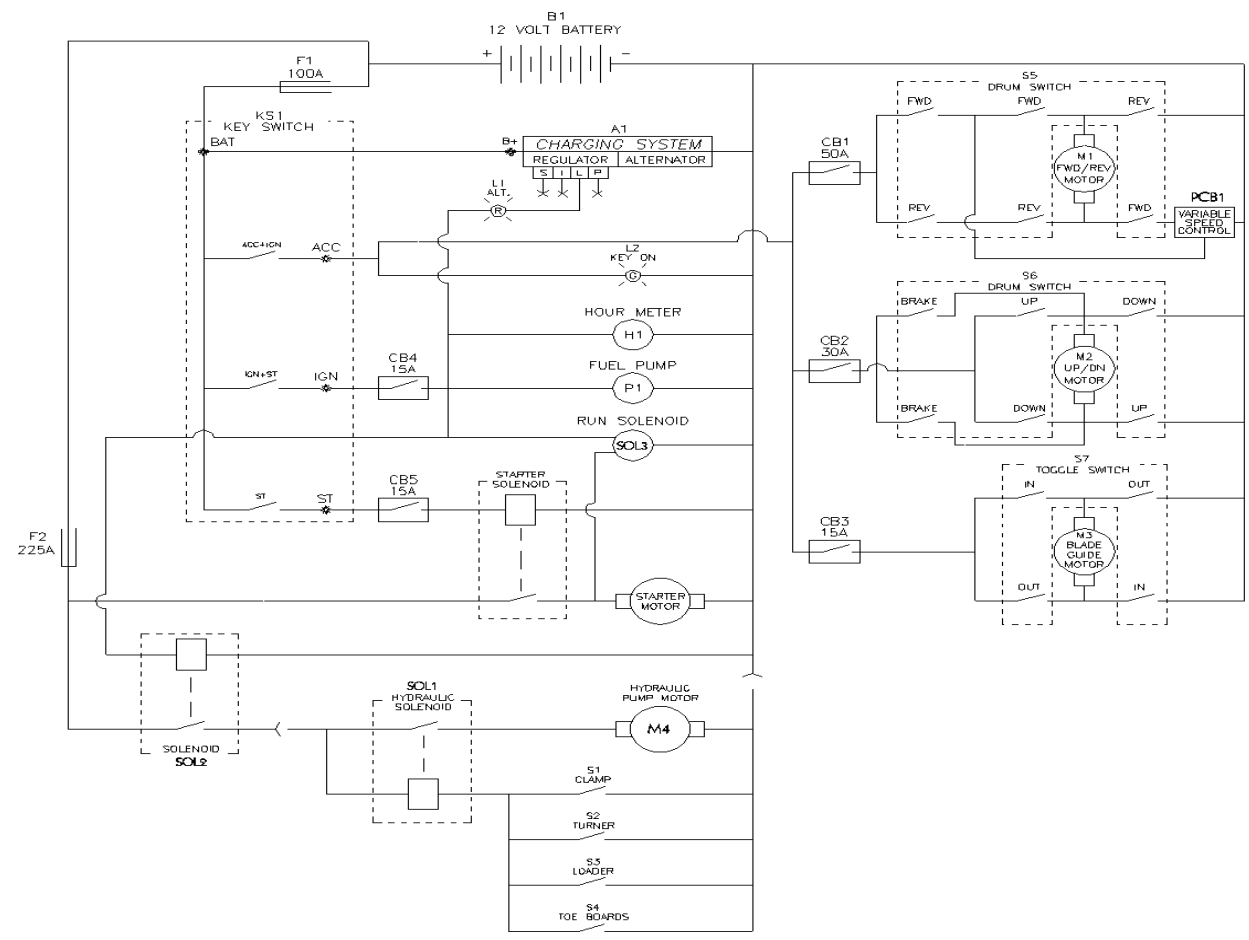

FIG. 5-5

**5.6 Electrical Symbol Diagram, LT30HD/LT40HD D20s (Rev. C7 - E6)**



**FIG. 5-6**

## 5.7 Electrical Components, LT30/LT40 D20/D20s

Item	Mfg. Part No.	Mfg.	Wood-Mizer Part No.	Description
A1	CS-130	Delco-Remy	050287 <sup>1</sup>	Alternator, 12 Volt, 105 Amp Maximum
B1	24M-7 <sup>2</sup>	Deka	P12315	Battery, 12 V Deep Cycle LT30HD/40HD ( <a href="#">See Section 5.10</a> )
CB1	30128-30	Cole-Hersee	E20486 <sup>3</sup>	Circuit Breaker, 30 Amp, 12 Volt, For Power Feed Motor, Auto Reset (U.S.)
	30407-50	Cole-Hersee	E20432	Circuit Breaker, 50 Amp, 12 Volt, For Power Feed Motor, Manual Reset (G.S.)
CB2	123A30A2	Richard's Elec	E20431 <sup>4</sup>	Circuit Breaker, 30 Amp, 12 Volt, For Up/Down Motor, Manual Reset
CB3	123A15A2	Richard's Elec	E20430 <sup>5</sup>	Circuit Breaker, 15 Amp, 12 Volt, For Ignition Circuit, Manual Reset
CB4	123A15A2	Richard's Elec	E20430 <sup>5</sup>	Circuit Breaker, 15 Amp, 12 Volt, For Start Circuit, Manual Reset
CB5	123A15A2	Richard's Elec	E20430 <sup>5</sup>	Circuit Breaker, 15 Amp, 12 Volt, For Blade Guide Motor, Manual Reset
F1	RL-100	Gould	P11549	Fuse Link, 100 Amp, 250 Volt For Main + 12 Volt Starter, Alternator
F2	RL-225	Gould	P11550	Fuse Link, 225 Amp, 250 Volt For Main + Alternator
H1	T40 Series	ENM Corp.	P09631	Hour Meter, 12 Volt, Low Power T40 Series
KS1	121801	General	P04350	Key Switch, 4-position (Accessory, Off, Ignition, Start)
L1	2128	General	P04986	Light, Red Warning, For Alternator Malfunction
L2	2129	General	P20436	Light, Green Indicator, For Key Switch In Acc Or Ign Position
M1	1149-001	Current App.	006747 <sup>6</sup>	Motor, 12 Volt Power Feed
M2	S.I. 2917-A	Leeson <sup>7</sup>	A04367	Motor, 12 Volt Up/Down
M3	P09698-1	Klauber	A10365	Motor, 12 Volt Blade Guide Arm 53:1 Gear
PCB1	024495	Wood-Mizer	024495 <sup>8</sup>	Circuit Board, Power Feed
S5	2601-AF2-S11	Square D	E20439	Drum Switch, (U.S.), Power Feed Fwd/Reverse Motor
S5	2601-AF2-S10	Square D	N/A	Drum Switch, (G.S.), Power Feed Fwd/Reverse Motor
S6	2601-AF2-S12	Square D	E20440	Drum Switch, Up/Down Motor
S7	1121-0004	McGill	P10006	Toggle Switch, Blade Guide In/Out Motor
SOL1	1502ES-12C7 U1B2S2	Syncho-Start	P12136	Solenoid, 12 Volt Pull/Hold Diesel Run

<sup>1</sup> 105A Alternator 050287 replaces 61A alternator P03804 originally supplied (no longer available from vendor). Requires replacement of mounting bracket (W12273). Existing brackets can be modified to accept 105A alternator by grinding enough material (approx. 1/16" - 1/8") from the bottom of the mounting plates to clear the larger alternator body.

<sup>2</sup> Replaces 724MF originally supplied.

<sup>3</sup> 30 Amp breaker replaces E20434 50 Amp breaker 10/9/95.

<sup>4</sup> Circuit Breaker Changed from Cole-Hersee #CH30407-30 to Richard's Electric #123A30A2 to improve durability and reduce cost (11/06).

<sup>5</sup> Circuit Breaker Changed from Cole-Hersee #CH30407-15 to Richard's Electric #123A15A2 to improve durability and reduce cost (11/06).

<sup>6</sup> Motor 006747 replaced 014359 supplied until 11/08. .25HP motor directly replaces .49HP motor P04140 (Owosso #PR-4P07Q). Requires two rubber boots (P03807) to protect external motor terminals.

<sup>7</sup> Replaces Owosso motor #PV-28147Q originally supplied (12/00).

<sup>8</sup> Replaces A20428 originally supplied before 4/99. New assembly includes LED indicator lights for easier troubleshooting. Modularized components and surface mount technology improve durability and power capability.

## 5.8 Electrical Components, LT30HD/LT40HD D20/D20s (Rev. E7 - F7)

Item	Mfg. Part No.	Mfg.	Wood-Mizer Part No.	Description
A1	CS-130	Delco-Remy	050287 <sup>1</sup>	Alternator, 12 Volt, 105 Amp Maximum
B1	24M-7 <sup>2</sup>	Deka	P12315	Battery, 12 V Deep Cycle LT30HD/40HD ( <a href="#">See Section 5.10</a> )
CB1	30128-30	Cole-Hersee	E20486 <sup>3</sup>	Circuit Breaker, 30 Amp, 12 Volt, For Power Feed Motor, Auto Reset (U.S.)
	30407-50	Cole-Hersee	E20432	Circuit Breaker, 50 Amp, 12 Volt, For Power Feed Motor, Manual Reset (G.S.)
CB2	123A30A2	Richard's Elec	E20431 <sup>4</sup>	Circuit Breaker, 30 Amp, 12 Volt, For Up/Down Motor, Manual Reset
CB3	123A15A2	Richard's Elec	E20430 <sup>5</sup>	Circuit Breaker, 15 Amp, 12 Volt, For Ignition Circuit, Manual Reset
CB4	123A15A2	Richard's Elec	E20430 <sup>5</sup>	Circuit Breaker, 15 Amp, 12 Volt, For Start Circuit, Manual Reset
CB5	123A15A2	Richard's Elec	E20430 <sup>5</sup>	Circuit Breaker, 15 Amp, 12 Volt, For Blade Guide Motor, Manual Reset
F1	RL-100	Gould	P11549	Fuse Link, 100 Amp, 250 Volt For Main + 12 Volt Starter, Alternator
F2	RL-225	Gould	P11550	Fuse Link, 225 Amp, 250 Volt For Hydraulic +12 Volt Circuit
H1	T40 Series	ENM Corp.	P09631	Hour Meter, 12 Volt, Low Power T40 Series
KS1	121801	General	P04350	Key Switch, 4-position (Accessory, Off, Ignition, Start)
L1	2128	General	P04986	Light, Red Warning, For Alternator Malfunction
L2	2129	General	P20436	Light, Green Indicator, For Key Switch In Acc Or Ign Position
M1	1149-001	Current App.	006747 <sup>6</sup>	Motor, 12 Volt Power Feed
M2	S.I. 2917-A	Leeson <sup>7</sup>	A04367	Motor, 12 Volt Up/Down
M3	P09698-1	Klauber	A10365	Motor, 12 Volt Blade Guide Arm 53:1 Gear
M4	08714	Monarch Hyd.	052807 <sup>8</sup>	Motor, 12 Volt Hydraulic Pump
PCB1	024495	Wood-Mizer	024495 <sup>9</sup>	Circuit Board, Power Feed
S1	07147	Monarch Hyd.	P12735	Switch, Hydraulic Pump Levers For Revisions E7+
S5 S5	2601-AF2-S11	Square D	E20439	Drum Switch, (U.S.), Power Feed Fwd/Reverse Motor
	2601-AF2-S10	Square D	N/A	Drum Switch, (G.S.), Power Feed Fwd/Reverse Motor
S6	2601-AF2-S12	Square D	E20440	Drum Switch, Up/Down Motor
S7	1121-0004	McGill	P10006	Toggle Switch, Blade Guide In/Out Motor
SOL1	586-902	Stancor	016371 <sup>10</sup>	Solenoid, 200 Amp Hydraulic Pump Motor
SOL2	120-943	Stancor	016372 <sup>11</sup>	Solenoid, Low-Cost Multi-Purpose 12 Volt 3 Terminal
SOL3	1502ES-12C7 U1B2S2	Syncho-Start	P12136	Solenoid, 12 Volt Pull/Hold Diesel Run

<sup>1</sup> 105A Alternator 050287 replaces 61A alternator P03804 originally supplied (no longer available from vendor). Requires replacement of mounting bracket (W12273). Existing brackets can be modified to accept 105A alternator by grinding enough material (approx. 1/16" - 1/8") from the bottom of the mounting plates to clear the larger alternator body.

<sup>2</sup> Replaces 724MFD originally supplied.

<sup>3</sup> 30 Amp breaker replaces E20434 50 Amp breaker 10/9/95.

<sup>4</sup> Circuit Breaker Changed from Cole-Hersee #CH30407-30 to Richard's Electric #123A30A2 to improve durability and reduce cost (11/06).

<sup>5</sup> Circuit Breaker Changed from Cole-Hersee #CH30407-15 to Richard's Electric #123A15A2 to improve durability and reduce cost (11/06).

- <sup>6</sup> Motor 006747 replaced 014359 supplied until 11/08. .25HP motor directly replaces .49HP motor P04140 (Owosso #PR-4P07Q). Requires two rubber boots (P03807) to protect external motor terminals.
- <sup>7</sup> Replaces Owosso motor #PV-28147Q originally supplied (12/00).
- <sup>8</sup> Bosch motor P09955 replaced by vendor with Iskra motor 1/06. Brush kit P09585 no longer available to service Bosch motor. Replace motor using kit 052807 ([See Form #1578](#) for applicable discount information). Use Brush Kit 038682 to service Iskra motor.
- <sup>9</sup> Replaces A20428 originally supplied before 4/99. New assembly includes LED indicator lights for easier troubleshooting. Modularized components and surface mount technology improve durability and power capability.
- <sup>10</sup> Solenoid Kit 016371 replaces Solenoid 015470. Kit includes solenoid and replacement instructions. If replacing original P09595 100 amp solenoid, order retrofit kit 015783.
- <sup>11</sup> Solenoid Kit 016372 replaces Solenoid P10449. Kit includes solenoid and replacement instructions.

**5.9 Electrical Components, LT30HD/LT40HD D20/D20s (Rev. C7 - E6)**

Item	Mfg. Part No.	Mfg.	WM Part No.	Description
A1	CS-130	Delco-Remy	050287 <sup>1</sup>	Alternator, 12 Volt, 105 Amp Maximum
B1	24M-7 <sup>2</sup>	Deka	P12315	Battery, 12 Volt (See Battery Specifications)
CB1	30128-30	Cole-Hersee	E20486 <sup>3</sup>	Circuit Breaker, 30 Amp, 12 Volt, Power Feed Motor, Auto Reset (U.S.)
	30407-50	Cole-Hersee	E20432	Circuit Breaker, 50Amp, 12 Volt, Power Feed Motor, Manual Reset(G.S.)
CB2	123A30A2	Richard's Elec	E20431 <sup>4</sup>	Circuit Breaker, 30 Amp, 12 Volt, Up/Down Motor, Manual Reset
CB3	123A15A2	Richard's Elec	E20430 <sup>5</sup>	Circuit Breaker, 15 Amp, 12 Volt, For Ignition Circuit, Manual Reset
CB4	123A15A2	Richard's Elec	E20430 <sup>5</sup>	Circuit Breaker, 15 Amp, 12 Volt, For Start Circuit, Manual Reset
CB5	123A15A2	Richard's Elec	E20430 <sup>5</sup>	Circuit Breaker, 15 Amp, 12 Volt, For Blade Guide Motor, Manual Reset
F1	RL-100	Gould	P11549	Fuse Link, 100 Amp, 250 Volt For Main + 12 Volt Starter, Alternator
F2	RL-225	Gould	P11550	Fuse Link, 225 Amp, 250 Volt For Hydraulic +12 Volt Circuit
H1	T40 Series	ENM Corp.	P09631	Hour Meter, 12 Volt, Low Power T40 Series
KS1	121801	General	P04350	Key Switch, 4-position (Accessory, Off, Ignition, Start)
L1	2128	General	P04986	Light, Red Warning, For Alternator Malfunction
L2	2129	General	P20436	Light, Green Indicator, For Key Switch In Acc Or Ign Position
M1	1149-001	Current App.	006747 <sup>6</sup>	Motor, 12 Volt Power Feed
M2	S.I. 2917-A	Leeson <sup>7</sup>	A04367	Motor, 12 Volt Up/Down
M3	P09698-1	Klauber	A10365	Motor, 12 Volt Blade Guide Arm 53:1 Gear
M4	08714	Monarch Hyd.	052807 <sup>8</sup>	Motor, 12 Volt Hydraulic Pump
PCB1	024495	Wood-Mizer	024495 <sup>9</sup>	Circuit Board, Power Feed
S1	03721	Monarch Hyd.	P09593	Switch, Hydraulic Pump Lever For Revisions E7+
S2	03721	Monarch Hyd.	P09593	Switch, Hydraulic Pump Lever For Revisions E7+
S3	03721	Monarch Hyd.	P09593	Switch, Hydraulic Pump Lever For Revisions E7+
S4	03721	Monarch Hyd.	P09593	Switch, Hydraulic Pump Lever For Revisions E7+
S5	2601-AF2-S11	Square D	E20439	Drum Switch, (U.S.), Power Feed Fwd/Reverse Motor
S5	2601-AF2-S10	Square D	N/A	Drum Switch, (G.S.), Power Feed Fwd/Reverse Motor
	03721	Monarch Hyd.	P09593	Switch, Hydraulic Pump Lever For Revisions C7-E6
S6	2601-AF2-S12	Square D	E20440	Drum Switch, Up/Down Motor
S7	1121-0004	McGill	P10006	Toggle Switch, Blade Guide In/Out Motor
SOL1	3336	Monarch Hyd.	P09595	Solenoid, Hydraulic Pump Motor
SOL2	120-943	United Tech.	016372 <sup>10</sup>	Solenoid, Low-Cost Multi-Purpose 12 Volt 3 Terminal
SOL3	1502ES-12C7 U1B2S2	Syncho-Start	P12136	Solenoid, 12 Volt Pull/Hold Diesel Run
<b>Revisions C7-E6 Only</b>				
S2	03721	Monarch Hyd.	P09593	Switch, Hydraulic Pump Lever
S3	03721	Monarch Hyd.	P09593	Switch, Hydraulic Pump Lever
S4	03721	Monarch Hyd.	P09593	Switch, Hydraulic Pump Lever

<sup>1</sup> 105A Alternator 050287 replaces 61A alternator P03804 originally supplied (no longer available from vendor). Requires replacement of mounting bracket (W12273). Existing brackets can be modified to accept 105A alternator by grinding enough material (approx. 1/16" - 1/8") from the bottom of the mounting plates to clear the larger alternator body.



<sup>2</sup> Replaces 724MF originally supplied.

<sup>3</sup> 30 Amp breaker replaces E20434 50 Amp breaker 10/9/95.

<sup>4</sup> Circuit Breaker Changed from Cole-Hersee #CH30407-30 to Richard's Electric #123A30A2 to improve durability and reduce cost (11/06).

<sup>5</sup> Circuit Breaker Changed from Cole-Hersee #CH30407-15 to Richard's Electric #123A15A2 to improve durability and reduce cost (11/06).

<sup>6</sup> Motor 006747 replaced 014359 supplied until 11/08. .25HP motor directly replaces .49HP motor P04140 (Owosso #PR-4P07Q). Requires two rubber boots (P03807) to protect external motor terminals.

<sup>7</sup> Replaces Owosso motor #PV-28147Q originally supplied (12/00).

<sup>8</sup> Bosch motor P09955 replaced by vendor with Iskra motor 1/06. Brush kit P09585 no longer available to service Bosch motor. Replace motor using kit 052807 ([See Form #1578](#) for applicable discount information). Use Brush Kit 038682 to service Iskra motor.

<sup>9</sup> Replaces A20428 originally supplied before 4/99. New assembly includes LED indicator lights for easier troubleshooting. Modularized components and surface mount technology improve durability and power capability.

<sup>10</sup> Solenoid Kit 016372 replaces Solenoid P10449. Kit includes solenoid and replacement instructions.

**5****Electrical Information***Battery Specifications, LT30/LT40/LT30HD/LT40HD D20/D20s***5.10 Battery Specifications, LT30/LT40/LT30HD/LT40HD D20/D20s**

Group No.	Type No.	Performance Level		Approximate Weight	Maximum Overall Dimensions		
		Cranking Performance	Reserve Capacity	Wet	Length	Width	Height
24	24M-7 <sup>1</sup>	875CC	120	45.0 lb. (20.41 kg)	10.75 in. (273 mm)	6.75 in. (171 mm)	9.875 in. (251 mm)

**TABLE 5-1**<sup>1</sup> Replaces 724MFD originally supplied.

5.11 Wiring Diagram, LT30/LT40 D20

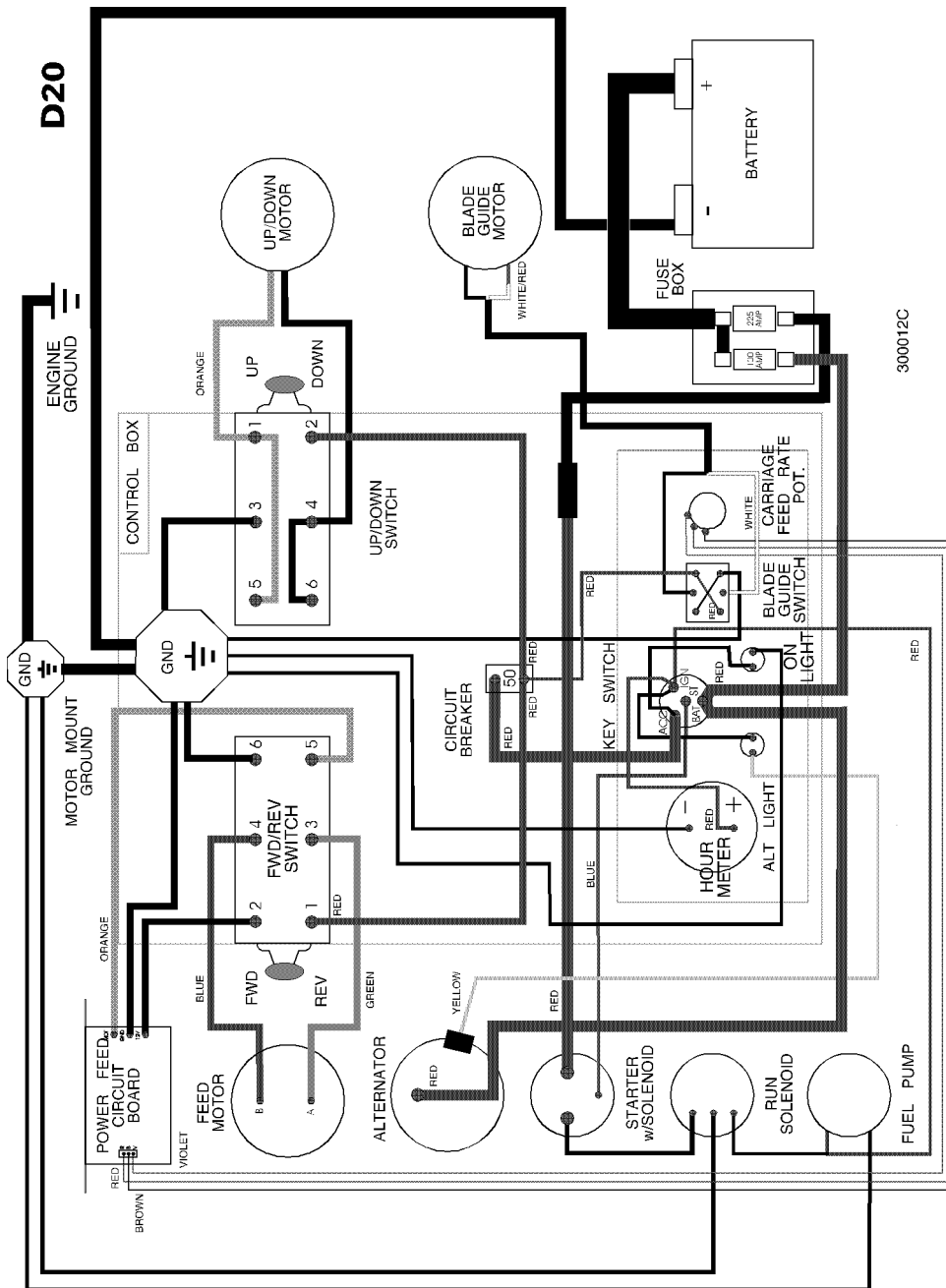

NOTE: Black Wires Not Labeled With Color Designations

FIG. 5-7

5.12 Wiring Diagram, LT30/LT40 D20s

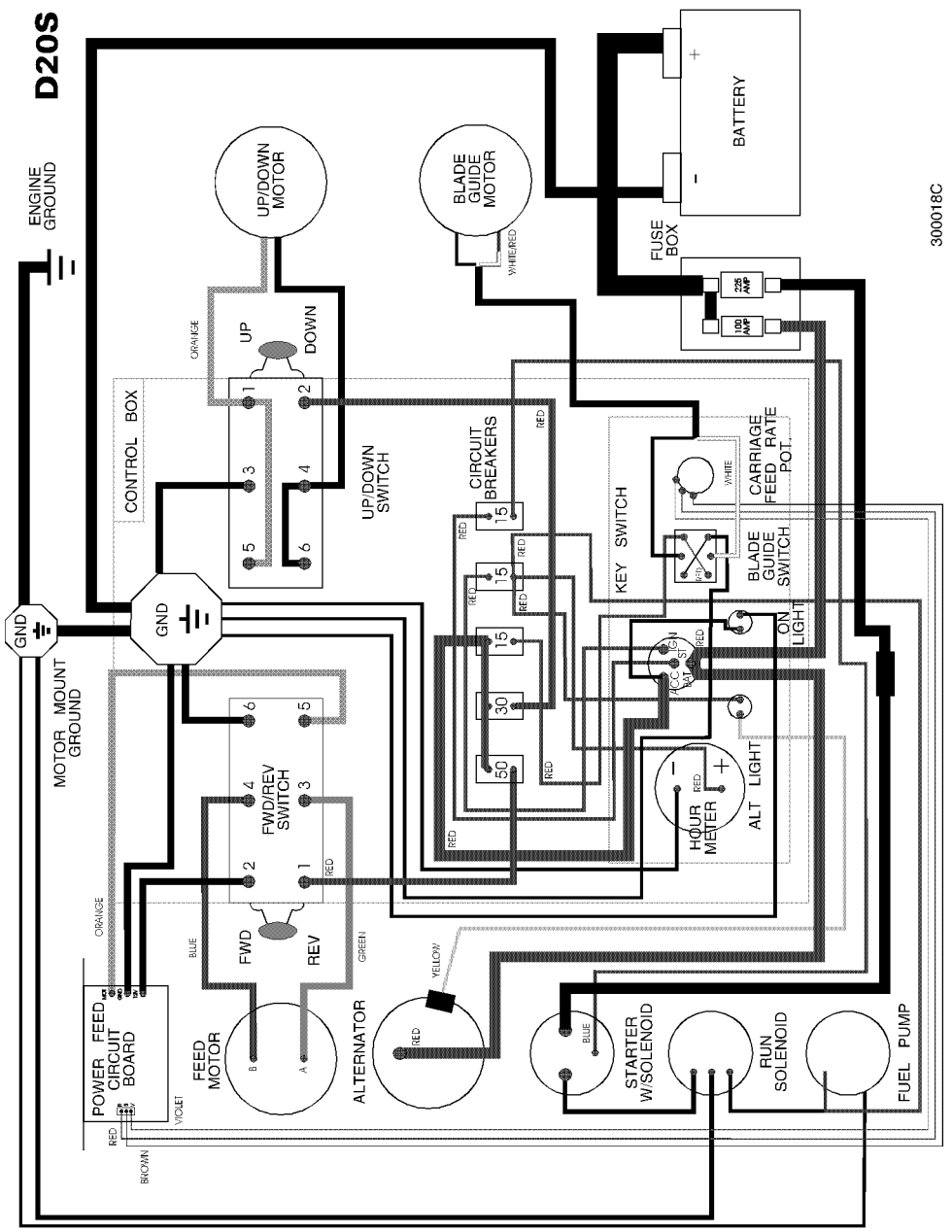

300018C

NOTE: Black Wires Not Labeled With Color Designations

FIG. 5-8

5.13 Wiring Diagram, LT30HD/LT40HD D20

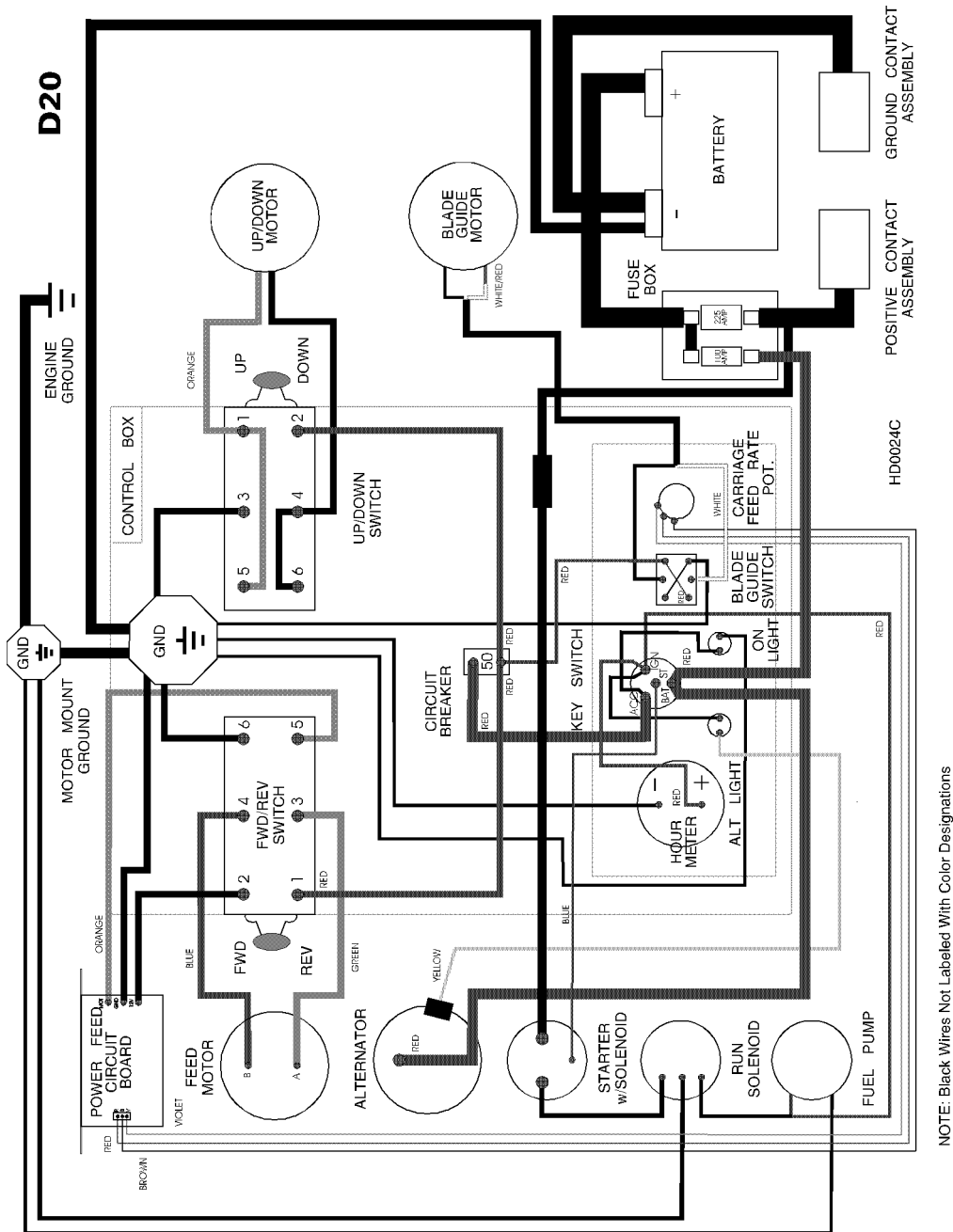

FIG. 5-9

## 5.14 Wiring Diagram, LT30HD/LT40HD D20s

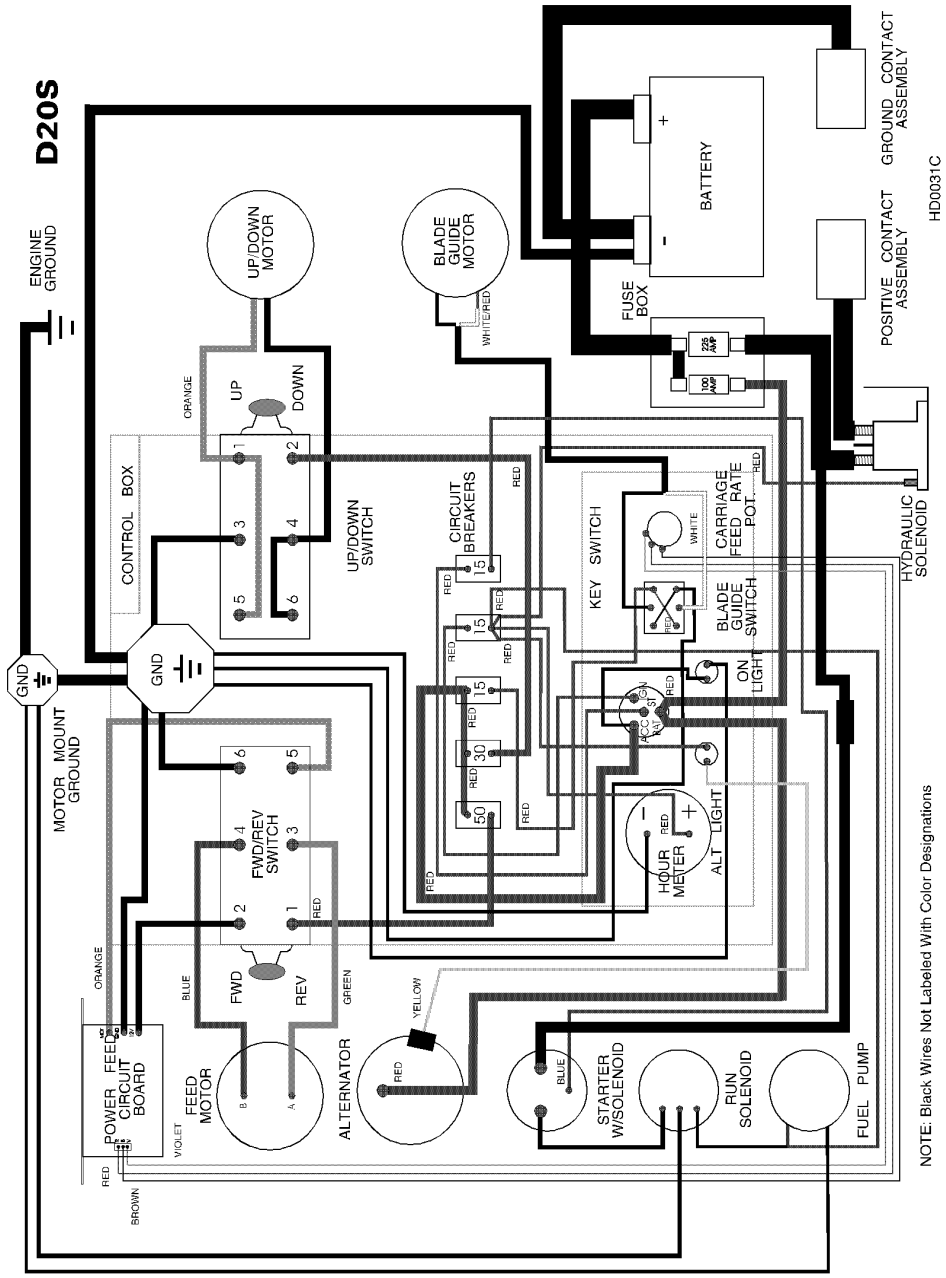

FIG. 5-10

---

## A

air cooling system 3-4

air filter (oil bath) 3-2

alternator belt 3-7

---

## B

battery handling 1-2

battery maintenance 3-6

battery specifications 5-12

belt

alternator tension 3-7

---

## E

electrical components (LT30/LT40) 5-7

electrical components (LT30HD/LT40HD) 5-8, 5-10

electrical symbol diagram (LT30/LT40) 5-2

electrical symbol diagram (LT30HD/LT40HD) 5-3, 5-4,  
5-5, 5-6

---

## F

fuel filter 3-5

---

## G

general information 1-3

---

## M

maintenance 3-1

miscellaneous maintenance 3-10

---

## O

oil 3-3

oil filter 3-3

---

## P

parts list

how to use 4-1

---

## R

refueling 1-1

replacement parts 4-1

RPM adjustments 3-11

---

## S

safety information 1-1

schematics 5-1

starting 2-1

above freezing 2-1

below freezing 2-2

rope 2-3

---

## W

wiring diagram (LT30/LT40) 5-13, 5-14

wiring diagram (LT30HD/LT40HD) 5-15, 5-16