

APPENDIX A G25-R ELECTRICAL INFORMATION

LT40HD Remote

Rev. H4.00 - J8.01

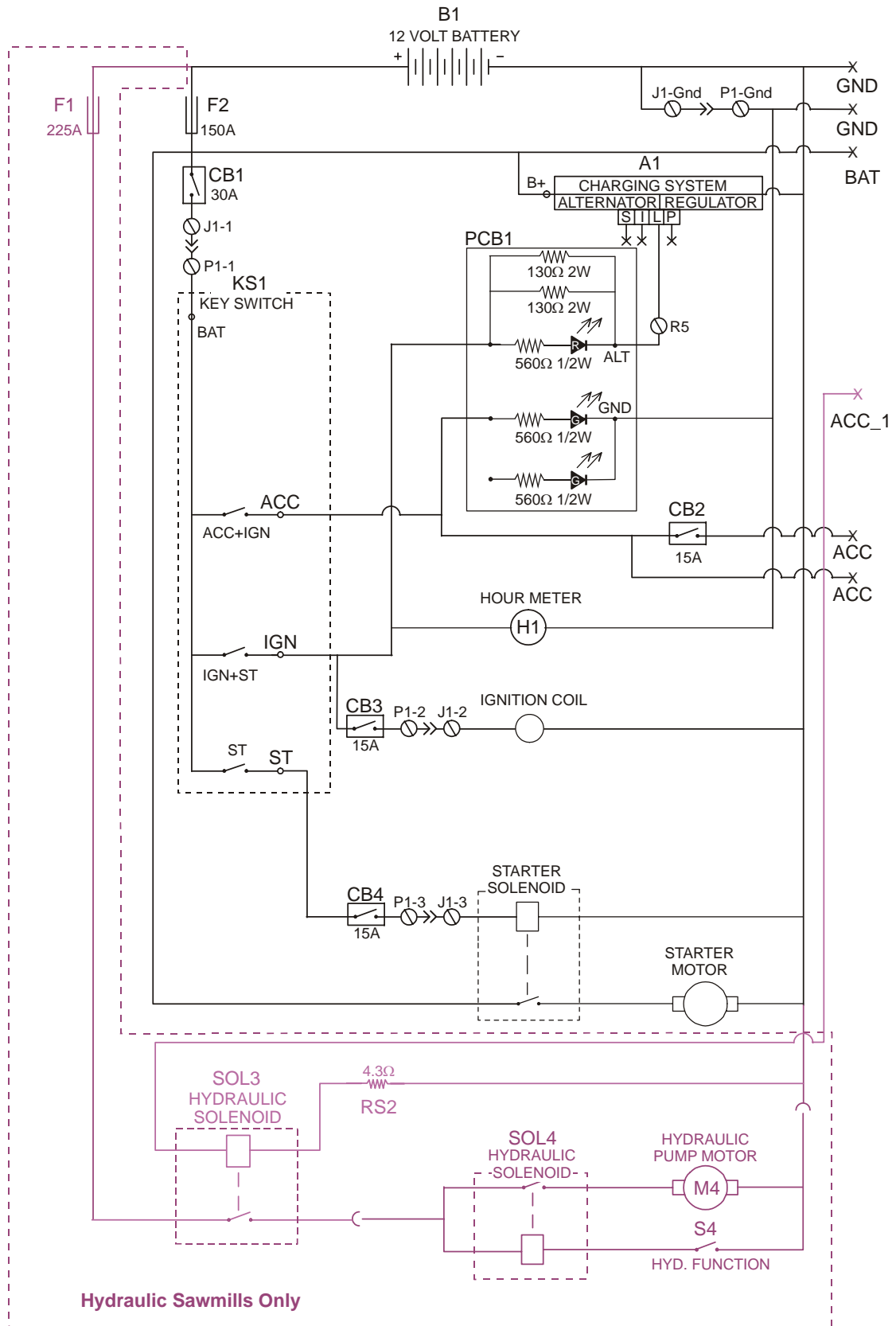

3H0796B

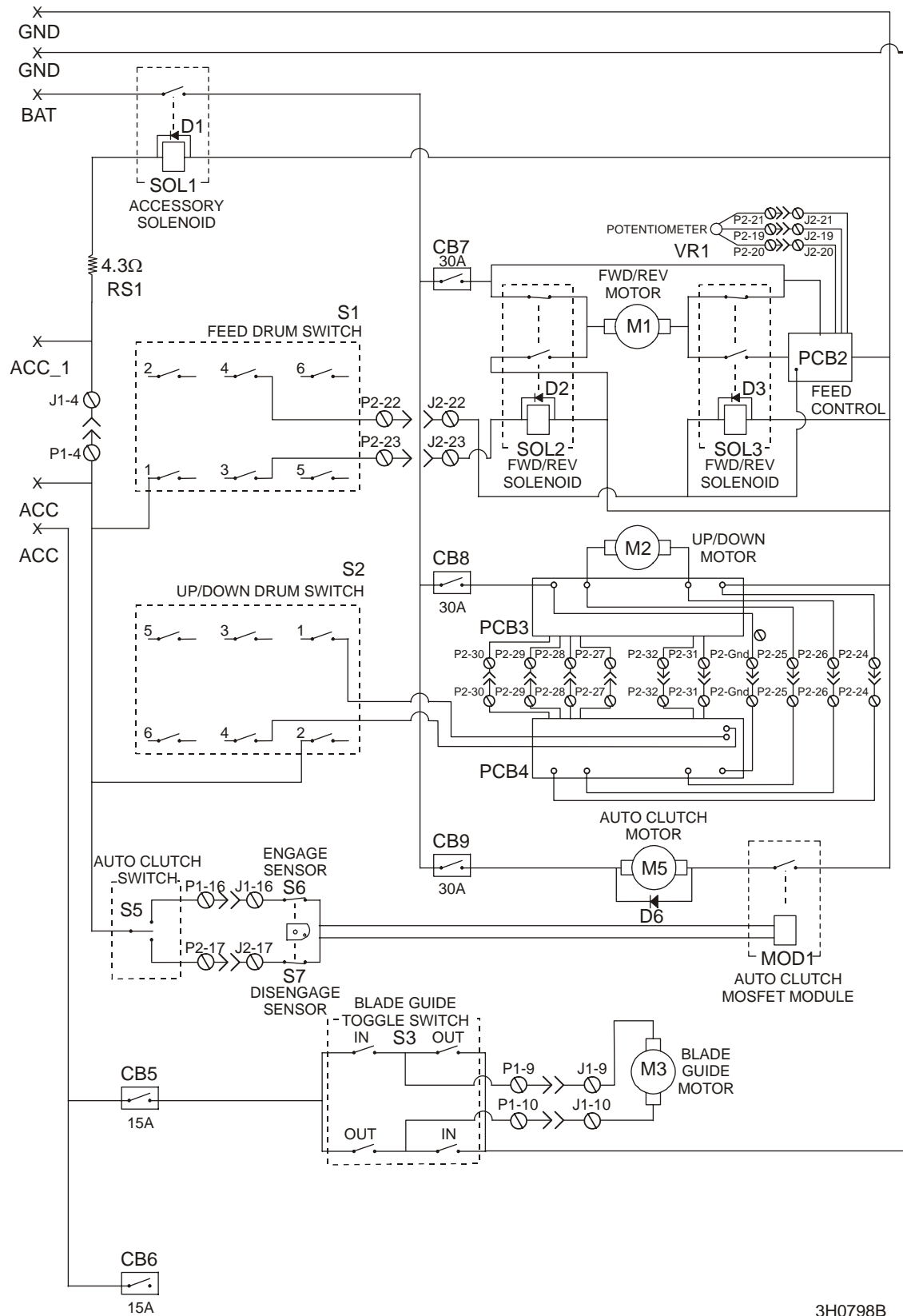

3H0798B

Component List				
Item	Mfg. Part No.	Mfg.	Wood-Mizer Part No.	Description
A1	CS-130	Delco-Remy	050287 ¹	Alternator, 12 Volt, 105 Amp Maximum
B1	24M-7	Deka	P12315	Battery, 12 Volt (See Battery Specifications)
CB1	123A30A2	Richard's Elec	E20431 ²	Circuit Breaker, 30A Manual Reset
CB2	123A15A2	Richard's Elec	E20430 ³	Breaker, 15 Amp Manual Reset, Accessory
CB3	123A15A2	Richard's Elec	E20430 ³	Breaker, 15 Amp Manual Reset, Ignition
CB4	123A15A2	Richard's Elec	E20430 ³	Breaker, 15 Amp Manual Reset, Start
CB5	123A15A2	Richard's Elec	E20430 ³	Breaker, 15 Amp Manual Reset, Blade Guide
CB6	123A15A2	Richard's Elec	E20430 ³	Breaker, 15 Amp Manual Reset, Not Used
CB7-CB9	1600-037-030-009	Mech Prod	024246	Breaker, 30A Manual Reset Panel Mount
D1 - D3	015426	Wood-Mizer	015426 ⁴	Diode Assembly, Solenoid Coil Chassis
D6	024629	Wood-Mizer	024629	Diode Assembly, Autoclutch
F1	RL-225	Gould	P11550	Fuse Link, 225 Amp, 250 Volt For Hydraulic + 12 Volt Circuit
F2	RL-150	Gould	023361	Fuse Link, 150A 250V For Main + 12 Volt Starter, Alternator
H1	732-0004	Redington Counters	015401 ⁵	Hour Meter, 12 Volt DC
J1	10.5310	Contact	E23106 ⁶	Insert, Female 10A 16P Scr. Term. 1-16
J2	10.5410	Contact	015671 ⁶	Insert, Female 10A 16P Scr. Term. 17-32
KS1	121801	General	P04350	Key Switch, 4-position (Accessory, Off, Ignition, Start)
M1	1149-001	Current App.	006747 ⁷	Motor, 12 Volt Power Feed
M2	1149-001	Wood-Mizer	006747 ⁸	Motor, 12 Volt Up/Down
M3	P09698-1	Klauber	A10365	Motor, 12 Volt Blade Guide Arm 53:1 Gear
M4	08714	Monarch Hyd.	052807 ⁹	Motor, 12 Volt Hydraulic Pump
M5	S.I. 2917-A	Leeson	016021	Motor, 12 Volt Autoclutch
MOD1	052791	Wood-Mizer	052791 ¹⁰	Module Assembly, Autoclutch Mosfet Upgrade
PCB1	015416	Wood-Mizer	015416	Circuit Board, LED Circuit (Gas/Elec)
P1	10.5300	Contact	E23105	Insert, Male 10A 16P Scr. Term. 1-16
P2	10.5400	Contact	015670	Insert, Male 10A 16P Scr. Term. 17-32
PCB2	024457	Wood-Mizer	024457	Circuit Board, Control Box Power Feed
PCB3	024270	Wood-Mizer	024270	Circuit Board, Remote Networks Distribution
PCB4	024269	Wood-Mizer	024269	Circuit Board, Remote Networks Control
RS1	024260	Wood-Mizer	024260	Wire Assembly, Accessory Solenoid Voltage Drop
RS2	024451	Wood-Mizer	024451	Wire Assembly, Hydraulic Solenoid Voltage Drop
S1	2601-AF2-S11	Square D	E20439	Drum Switch, Power Feed Fwd/Reverse Motor
S2	2601-AF2-S12	Square D	E20440	Drum Switch, Up/Down Motor
S3	34-591Q	Pollak	024200	Toggle Switch, Blade Guide In/Out Motor
S4	024198	Wood-Mizer	024198	Switch, Hydraulic Pump Levers
S5	CH-55015	Indy Wire	051346 ¹¹	Switch, On/On Toggle SPDT
S6, S7	024627	Wood-Mizer	024627	Sensor Assembly, Proximity Magnetic
SOL1	120-943	Stancor	016372 ¹²	Solenoid Kit, Accessory Circuit
SOL2-SOL3	586-911	Stancor	016370 ¹³	Solenoid Kit, 200A 12V DPST
SOL4,SOL10	586-902	Stancor	016371 ¹⁴	Solenoid Kit, 200A 12V SPST Hydraulic Pump Motor
VR1	024450-1	Wood-Mizer	024450-1	Potentiometer, Variable Resistance Power Feed

¹ 105A Alternator 050287 replaces 61A alternator P03804 originally supplied prior to Rev. J4.00 (no longer available from vendor). Requires replacement of mounting bracket (014509).

Electrical Information

- ² Circuit Breaker Changed from Cole-Hersee #CH30407-30 to Richard's Electric #123A30A2 to improve durability and reduce cost (11/06).
- ³ Circuit Breaker Changed from Cole-Hersee #CH30407-15 to Richard's Electric #123A15A2 to improve durability and reduce cost (11/06).
- ⁴ All Solenoid Kits include Diode Wire Assembly 015426 (8/04).
- ⁵ Was ENM Corp. #T14BH517BC9 (2/09).
- ⁶ Insert parts manufactured by Contact replace those manufactured by Thomas & Betts to improve durability (Rev. J3.02).
- ⁷ Motor 006747 replaced 014359 supplied until 11/08.
- ⁸ Motor 006747 replaced P04140 and Service Kit A07974 supplied until 5/09.
- ⁹ Bosch motor P09955 replaced by vendor with Iskra motor 1/06. Brush kit P09585 no longer available to service Bosch motor. Replace motor using kit 052807 ([See Form #1578](#) for applicable discount information). Use Brush Kit 038682 to service Iskra motor.
- ¹⁰ Mosfet Upgrade Kit 052791 replaces Mosfet Module 024168 originally supplied. Kit includes upgraded Mosfet and Capacitor Assembly 024163 to protect against inductive voltage spikes (5/06).
- ¹¹ 051346 On/On Toggle Switch replaces 015665 On/Off/On Toggle Switch supplied before 8/03. Center OFF position not required for Autoclutch operation.
- ¹² Solenoid Kit 016372 replaces Solenoid P10449. Kit includes solenoid and replacement instructions. Diode Wire Assembly 015426 added 8/04.
- ¹³ Solenoid Kit 016370 replaces Solenoid 015417. Kit includes solenoid and replacement instructions. Diode Wire Assembly 015426 added 8/04.
- ¹⁴ Solenoid Kit 016371 replaces Solenoid 015470. Kit includes solenoid and replacement instructions. Diode Wire Assembly 015426 added 8/04.

Battery Specifications							
Group No.	Type No.	Performance Level		Approximate Weight	Maximum Overall Dimensions		
		Cranking Performance	Reserve Capacity	Wet	Length	Width	Height
24	24M-7	875CC	120	45.0 lb. (20.41 kg)	10.75 in. (273 mm)	6.75 in. (171 mm)	9.875 in. (251 mm)

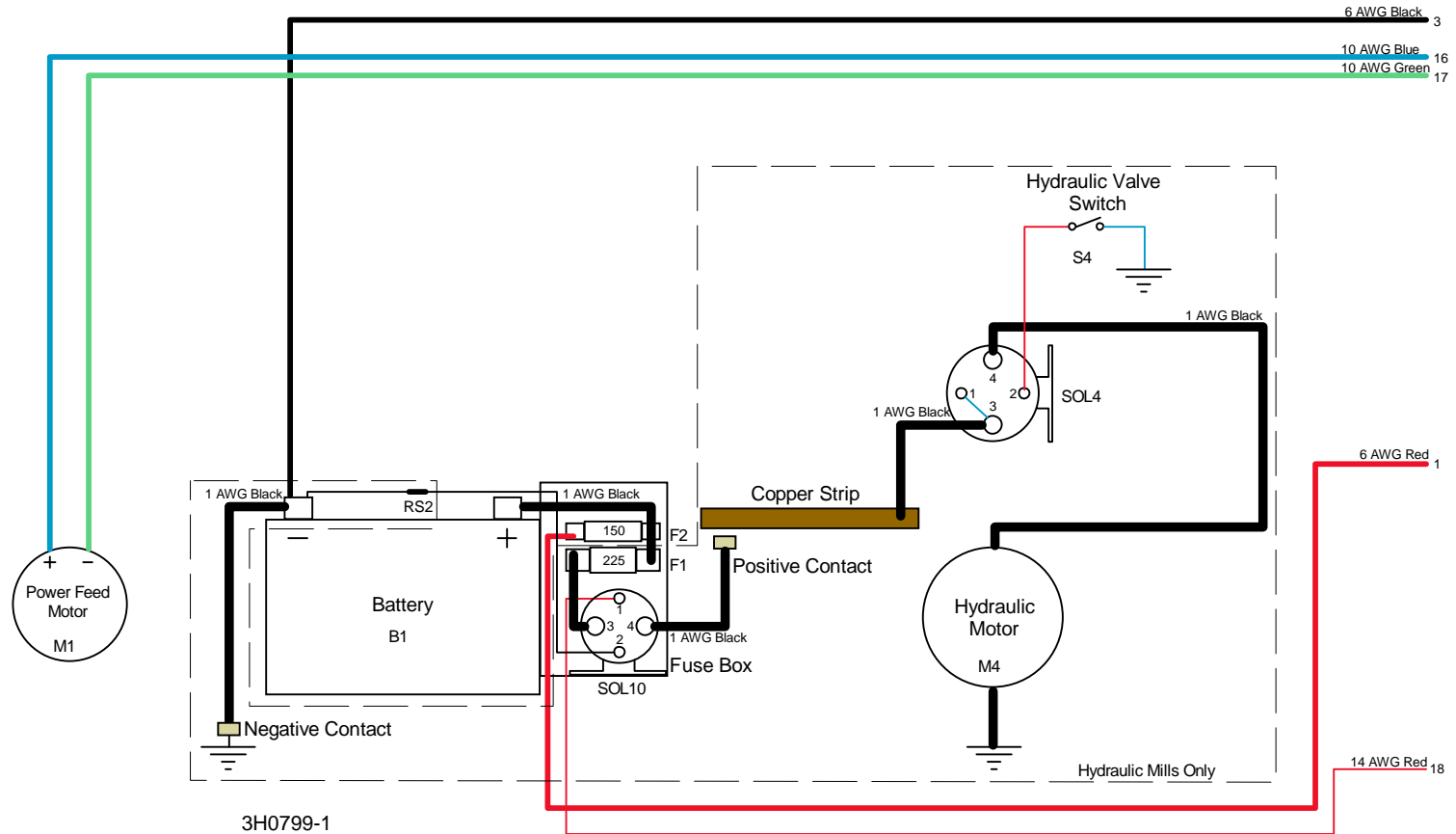

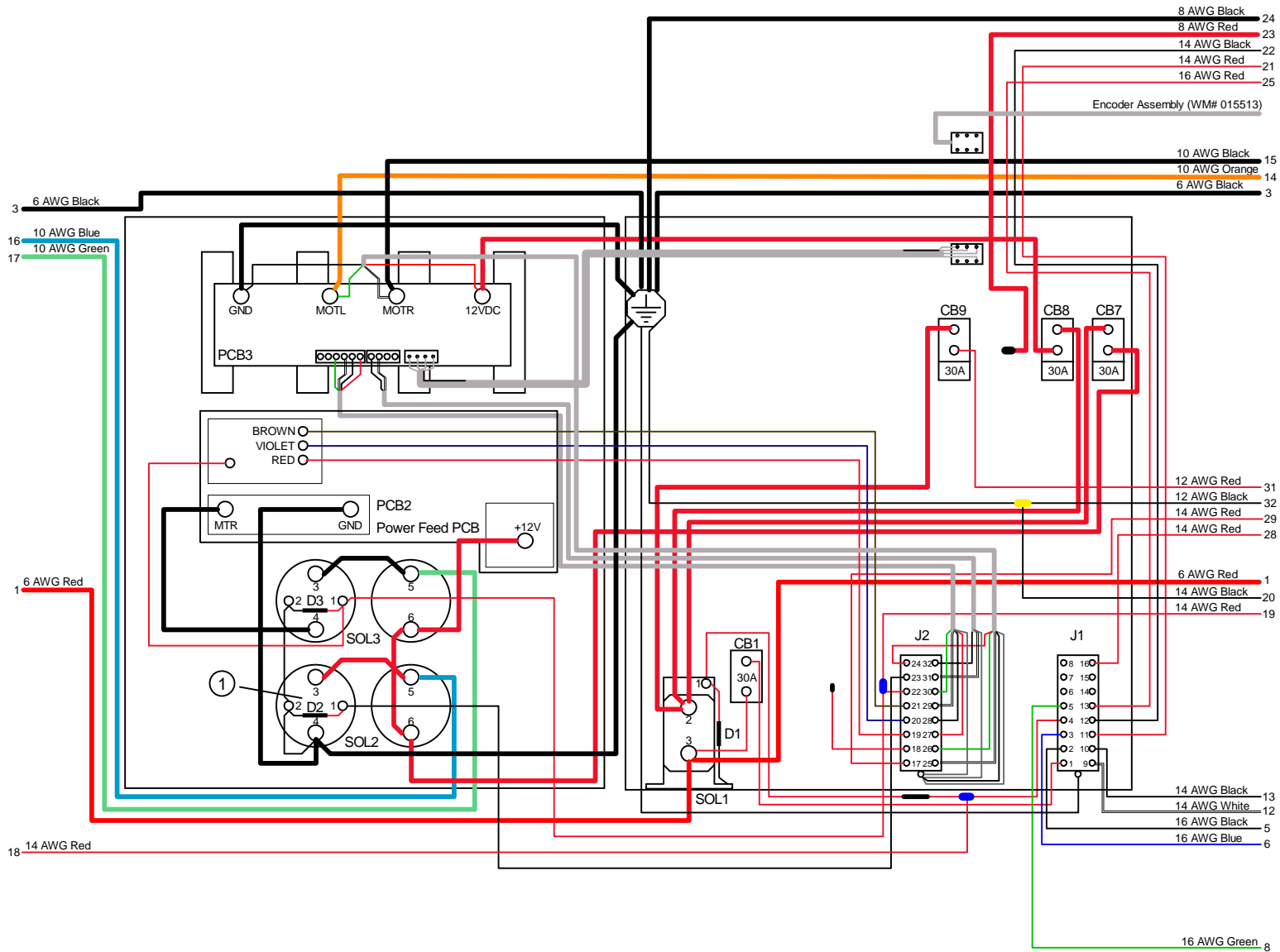

3H0799-2B

Wood-Mizer Part #015426 - Diode Assy, Solenoid Coil Chassis GND
Quantity 3

Electrical Information

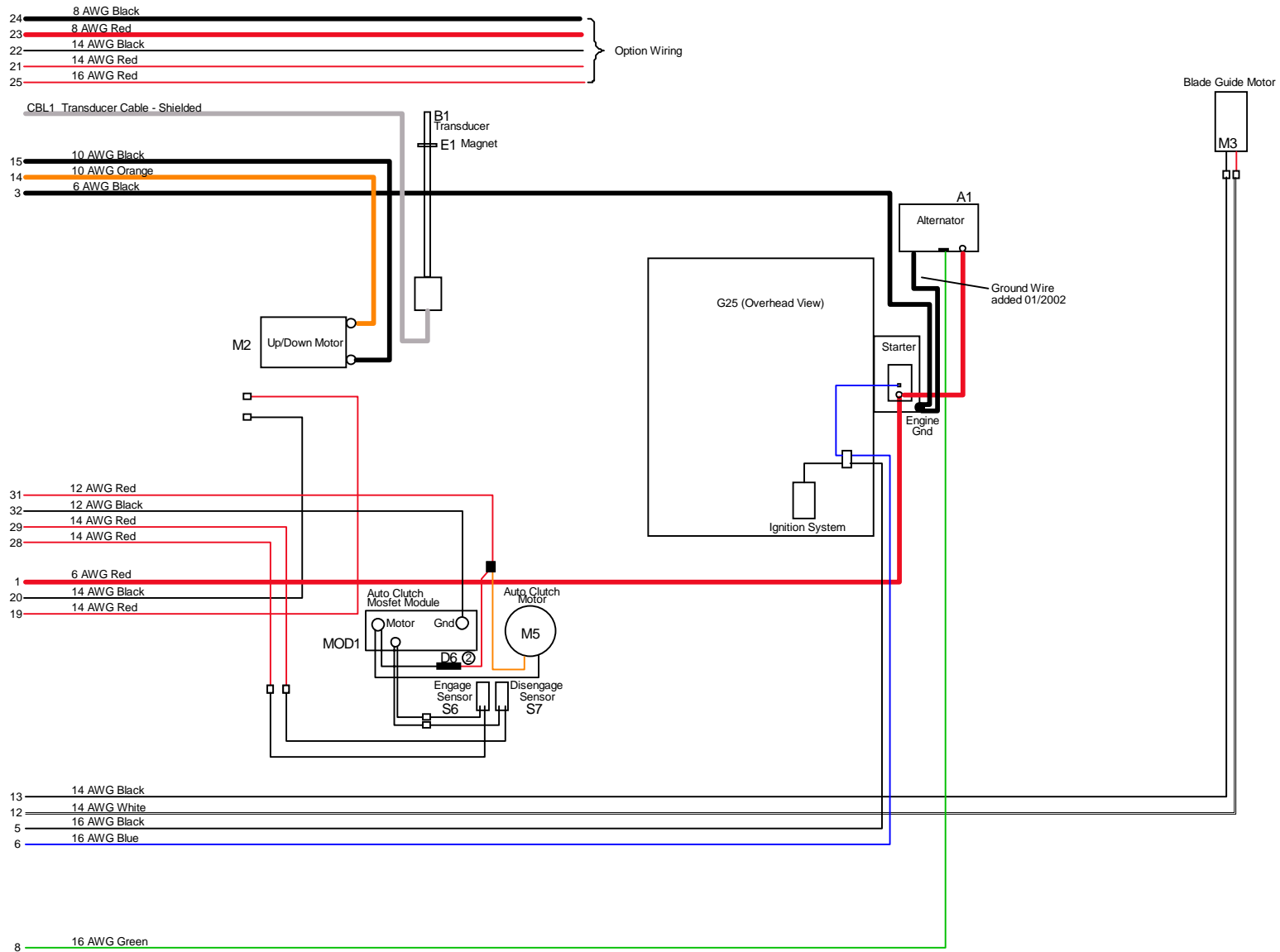

© Wood-Mizer Part #024629 - Wire Assy, Free Wheeling Diode SS AC

3H0799-3B

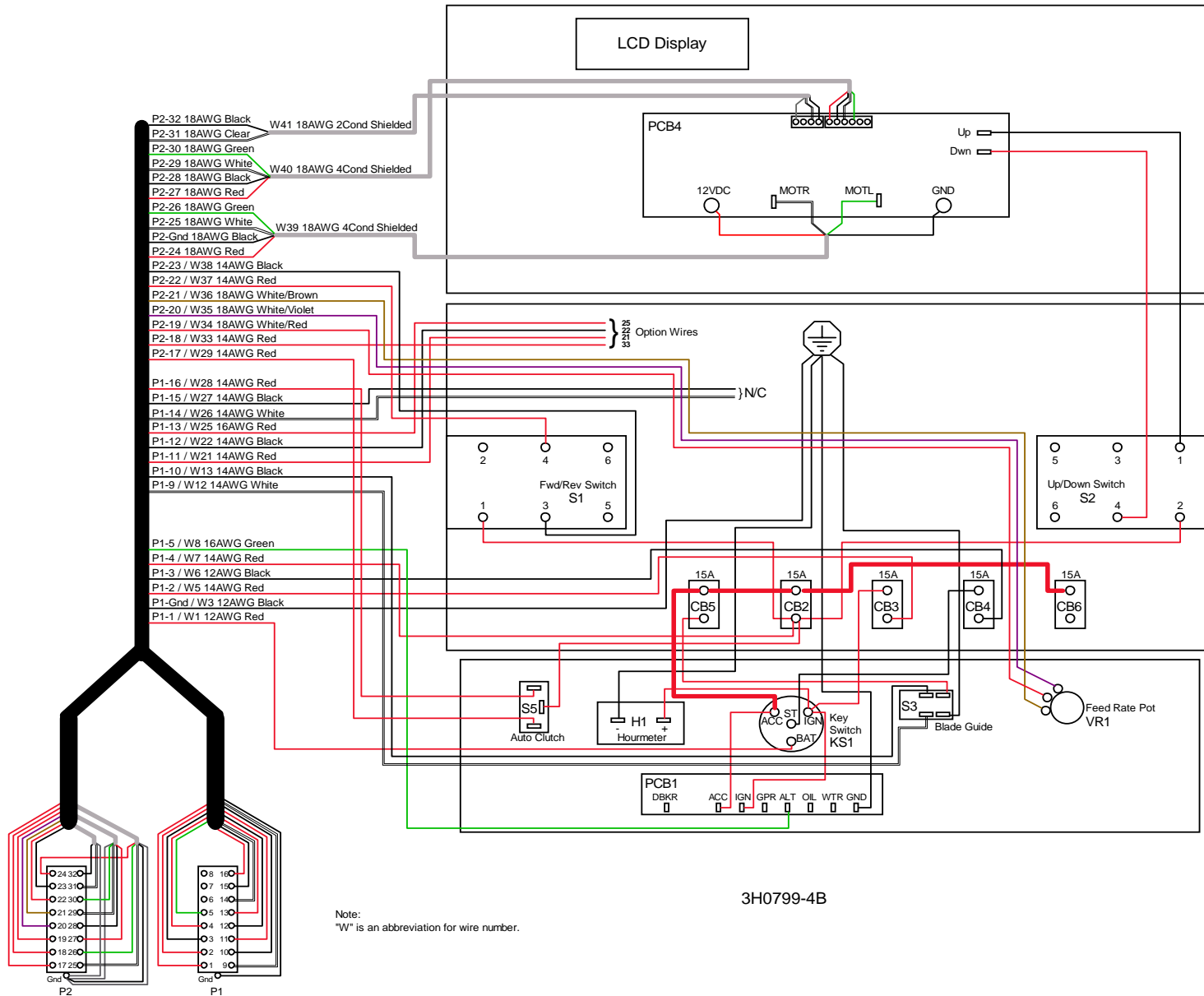

3H0799-4B

Note:
"W" is an abbreviation for wire number.

