

G38S ELECTRICAL INFORMATION

**LT40HD Super
LT50HD**

**Rev. K4.00+
Rev. A6.00+**

Component List		
Item	Wood-Mizer Part No.	Description
A1	023695	Alternator, 140 Amp
BR1	069519 ¹	Brake, Up/Down
CB1	015527	Breaker, 70 Amp Man.Reset Panel Mount, Up/Dn & Pwr Feed
CB3	E20430	Breaker, 15 Amp Manual Reset, Blade Guide
CB4	E20430	Breaker, 15 Amp Manual Reset, Accessory
CB5	E20430	Breaker, 15 Amp Manual Reset, Ignition
CB6	E20430	Breaker, 15 Amp Manual Reset, Start
CB7	E20430	Breaker, 15 Amp Manual Reset, Board Return
D1, D8 - D10	015426	Diode Assembly, Solenoid Coil Chassis
D7	024123	Diode Assembly, Inductive Kick Protection
D11	069678 ²	Diode OR Assembly, Up/Down Brake
F1	053340	Fuse, 450A 32V Mega
F2	053339	Fuse, 225A 32V Mega
G1	025841 ³	Battery, 12 Volt (See Battery Specifications)
H1	015401	Hour Meter, 12 Volt DC
HARN3	053355	Harness Assembly, Dual-Axis Motor Control
KS1	P04350	Key Switch, 4-position (Accessory, Off, Ignition, Start)
L6	016371	Solenoid Kit, 200A 12V SPST
M1	024169	Motor, 3/4HP 12VDC TEFC Power Feed w/o Base
M2	053682	Motor, 1HP 12VDC Up/Down
M3	A10365	Motor, 12 Volt Blade Guide Arm 53:1 Gear
M4	A10365	Motor, 12 Volt Board Return 53:1 Gear
M5, M6	052807	Motor, 12 Volt Hydraulic Pump
PCB2	015409	Board, LED Circuit
PNL2	057821LS-FR	Drive Assembly, Super NR Dual-Axis
RS2	024451	Wire Assembly, Hydraulic Solenoid Voltage Drop
S1	E20439	Drum Switch, Power Feed Fwd/Reverse Motor
S2	E20440	Drum Switch, Up/Down Motor
S3	024200	Toggle Switch, Blade Guide In/Out Motor
S4	024200	Toggle Switch, Board Return Motor
S5	024198	Switch, Hydraulic Pump Levers
S6		Switch, Oil Pressure Sensor
SOL8 - SOL9, SOL10	016371	Solenoid Kit, 200A 12V SPST Hydraulic Pump Motor
V1	016280	Valve, Waterlube Solenoid
VR1	024450-1	Potentiometer, Variable Resistance Power Feed

¹ Brake added LT40 Super Rev. J7.06, LT40HD Super Rev. K3.05 & LT50HD Rev. A5.05 to prevent saw head from drifting during sawing. Use retrofit kit 062570 to retrofit previous revisions.

² Up/Down Brake Diode OR Assembly 069678 added LT40 Super Rev. J7.12, LT40HD Super Rev. K3.11 & LT50HD Rev. A5.11 to prevent the brake from de-energizing while moving the saw head slowly. Use retrofit kit 069678-FR to retrofit previous revisions.

³ Battery 025841 replaced 12 Volt Battery (015475) supplied prior to LT40 Super Rev. J7.09, LT40HD Super Rev. K3.08 and LT50 Rev. A5.08.

Battery Specifications							
Group No.	Type No.	Performance Level		Approx. Weight (Wet)	Maximum Overall Dimensions		
		Cranking Performance	Reserve Capacity		Length	Width	Height
31	8A31DTM ¹	1000	185	59 lb. (26 Kg)	13" (330 mm)	6 3/4" (171 mm)	9 1/2" (241 mm)

¹ Battery 8A31DTM replaced battery 1131XPMF supplied prior to LT40 Super Rev. J7.09, LT40HD Super Rev. K3.08 and LT50 Rev. A5.08.

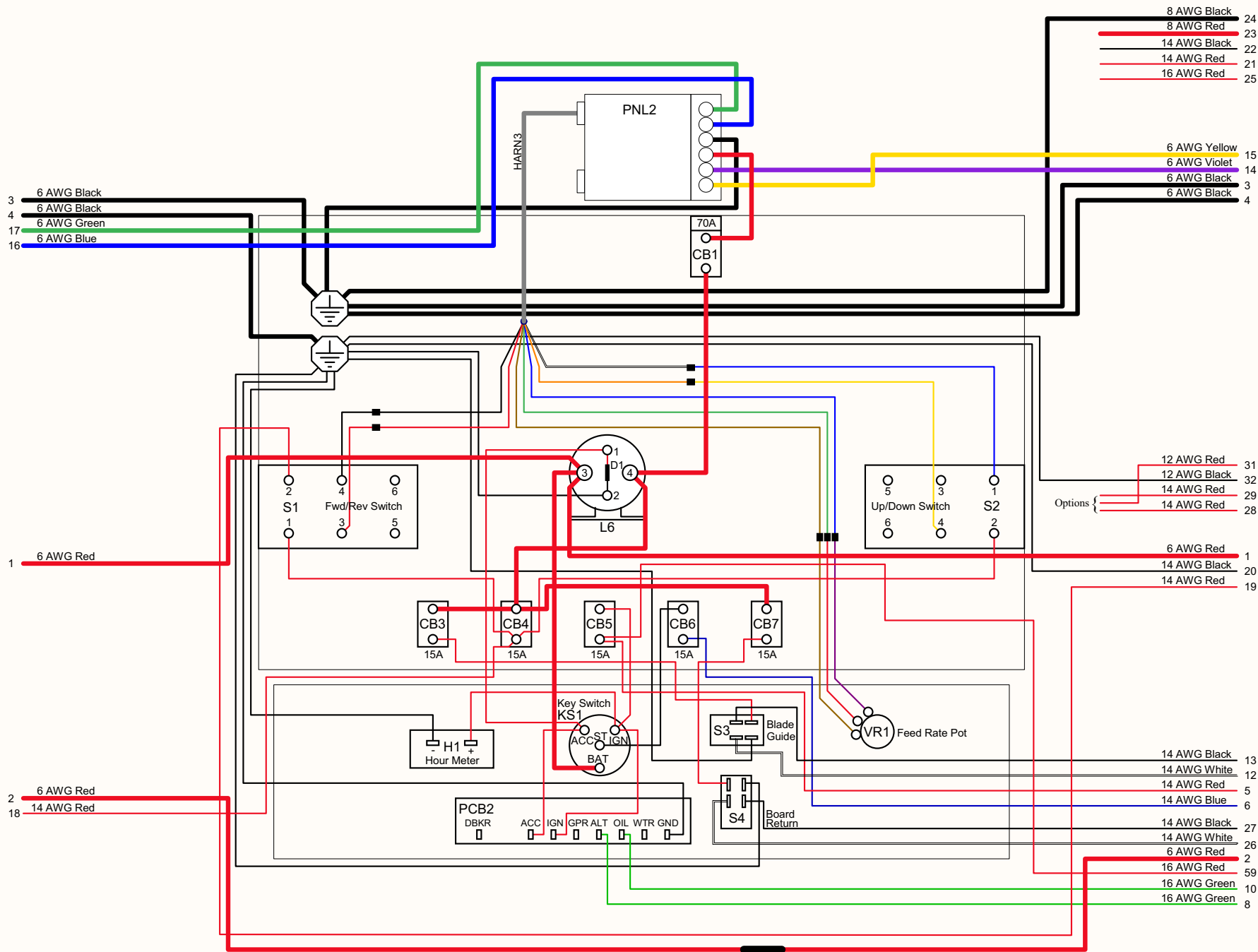

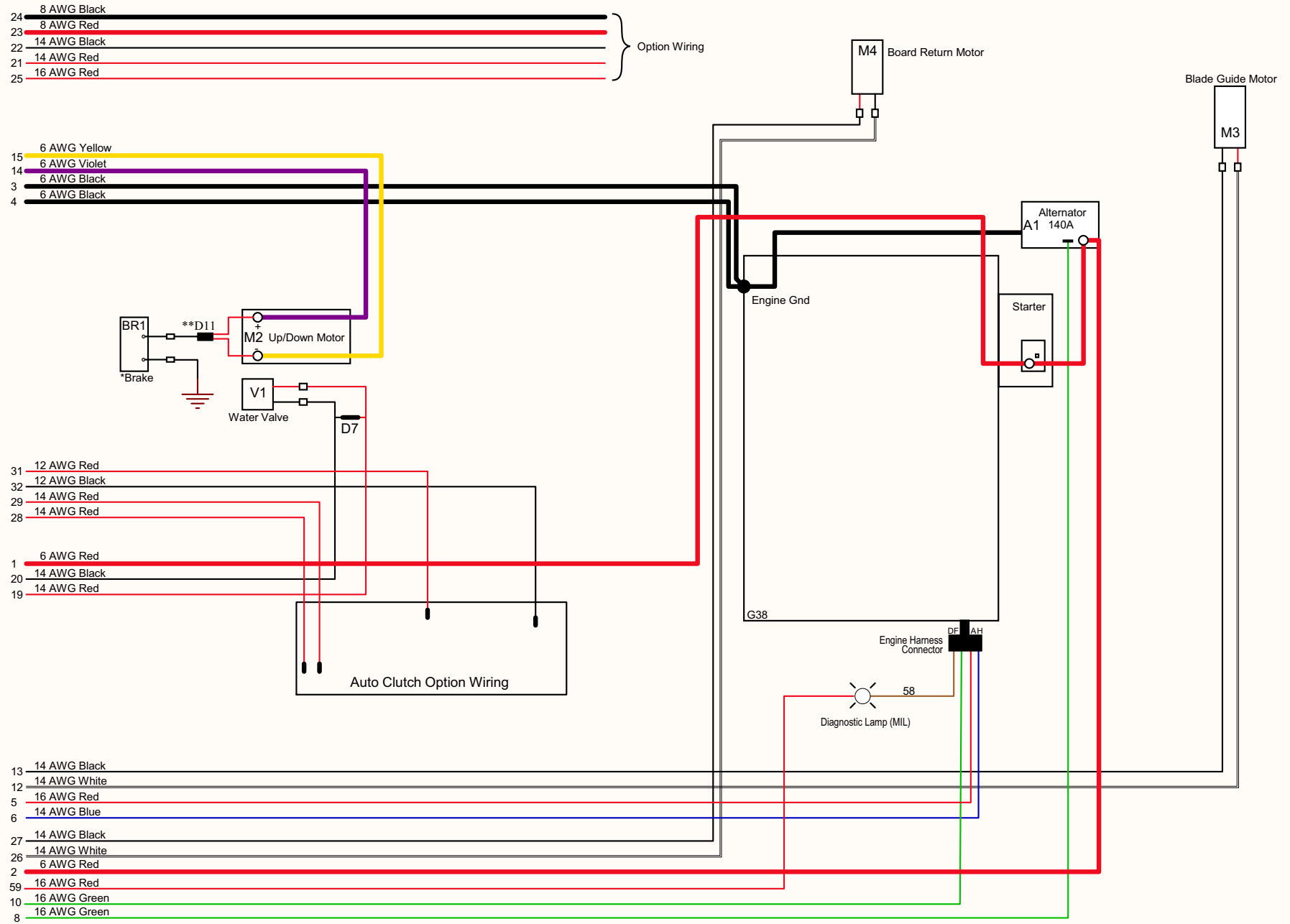

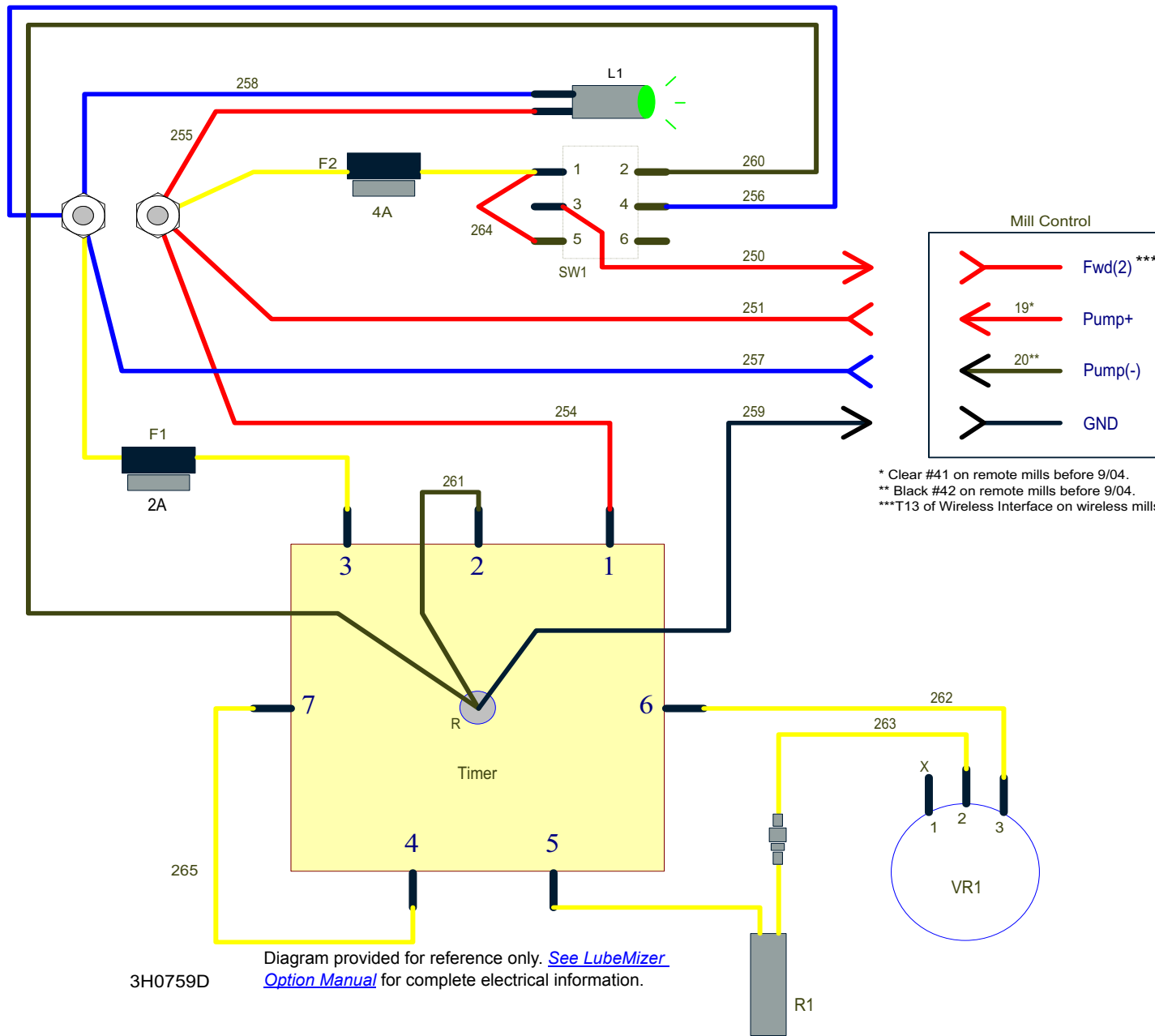

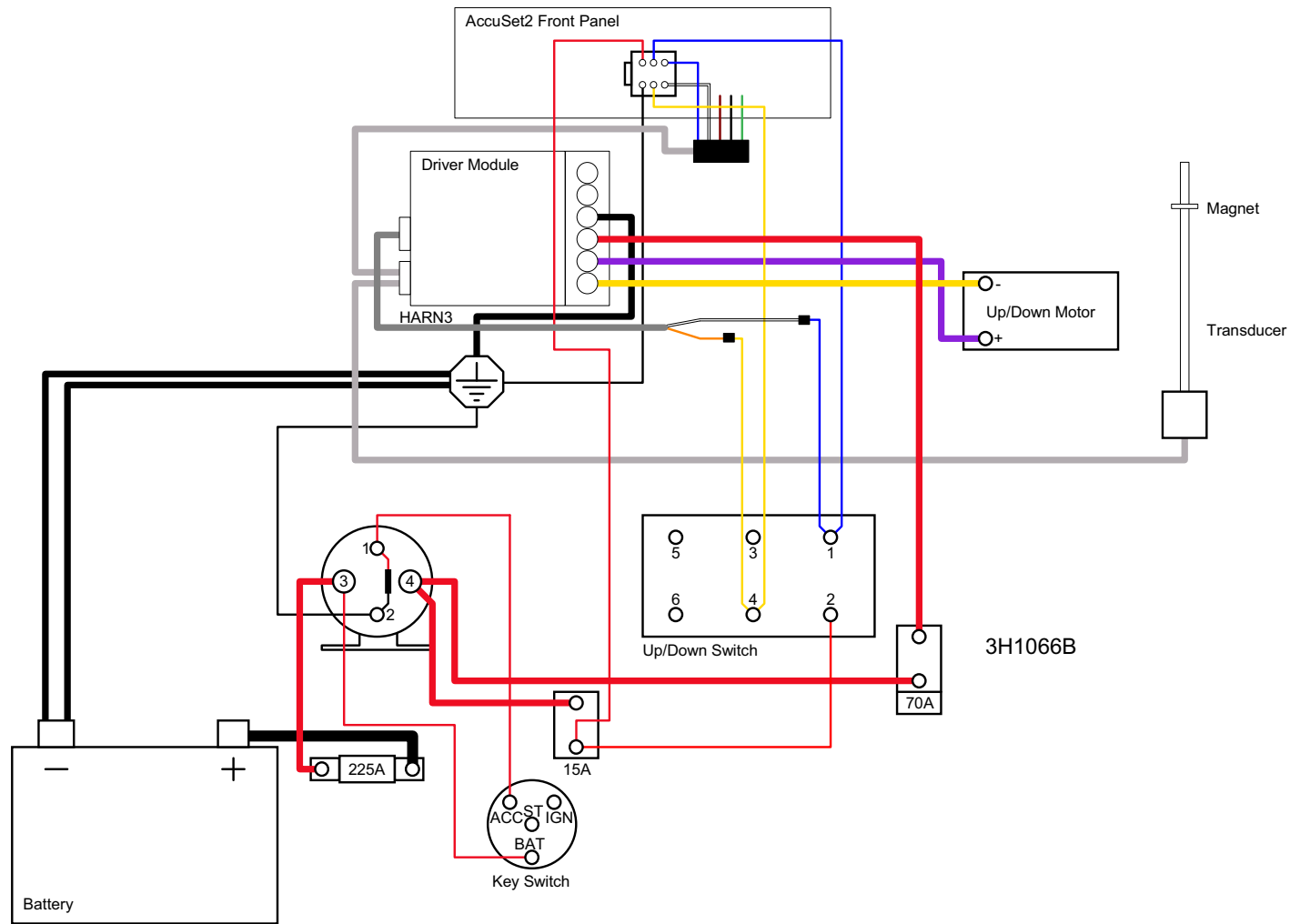

Diagram provided for reference only. [See Accuset 2 Option Manual](#) for complete electrical information.