

G15 Engine

**Safety, Operation, Maintenance
& Parts Manual**

034804 Engine, G15 Kohler **rev. D**

Safety is our #1 concern!

Form #940

**Used with
LT15G15**

rev. D2.00 - E6.09



WARNING! Read and understand this manual before using this machine.

California
Proposition 65 Warning



WARNING: Breathing gas/diesel engine exhaust exposes you to chemicals known to the State of California to cause cancer and birth defects or other reproductive harm.

Always start and operate the engine in a well-ventilated area.
If in an enclosed area, vent the exhaust to the outside.
Do not modify or tamper with the exhaust system.
Do not idle the engine except as necessary.

For more information go to **www.P65warnings.ca.gov**.



WARNING: Drilling, sawing, sanding or machining wood products can expose you to wood dust, a substance known to the State of California to cause cancer. Avoid inhaling wood dust or use a dust mask or other safeguards for personal protection.

For more information go to **www.P65Warnings.ca.gov/wood**.

Active Patents assigned to Wood-Mizer, LLC

Wood-Mizer, LLC has received patents that protect our inventions which are a result of a dedication to research, innovation, development, and design. Learn more at: woodmizer.com/patents

©2024 Wood-Mizer LLC

Printed in the United States of America, all rights reserved. No part of this manual may be reproduced in any form by any photographic, electronic, mechanical or other means or used in any information storage and retrieval system without written permission from

Wood-Mizer, LLC
8180 West 10th Street
Indianapolis, Indiana 46214

SECTION 1 SAFETY

1.1 Safety 1-1

SECTION 2 OPERATION

2.1 Starting The Engine 2-1

SECTION 3 MAINTENANCE

3.1 Safety 3-1
 3.2 Cooling System 3-1
 3.3 Air Filter & Pre-Cleaner 3-1
 3.4 Fuel Filter 3-1
 3.5 Battery 3-1
 3.6 Miscellaneous Maintenance 3-2
 3.7 RPM Adjustments 3-2

SECTION 4 REPLACEMENT PARTS

4.1 Engine Assembly 4-1
 LT15 Rev. E1.00+ 4-1
 4.2 Engine Assembly 4-3
 LT15 Rev. D4.00 - D7.00 4-3
 4.3 Engine Assembly 4-5
 LT15 Rev. D2.00 - D3.00 4-5
 4.4 Throttle/Clutch Assembly 4-7
 LT15 G13/G15 Rev. E1.00 - E6.09 4-7
 4.5 Throttle/Clutch Assembly 4-9
 LT15 Rev. D4.00 - D7.00 4-9
 4.6 Throttle/Clutch Assembly 4-11
 LT15 Rev. D3.00 4-11
 4.7 Throttle/Clutch Assembly 4-13
 LT15 Rev. A1.00 - D2.00 4-13

SECTION 1 SAFETY

This manual is provided as a supplement to the equipment manufacturer's manuals.

This manual provides information specific to the use of this equipment on the Wood-Mizer® sawmill. Refer to the sawmill operator's manual and manufacturer's manual before attempting to operate this equipment.

NOTICE Read the sawmill operator's manual and engine manufacturer's manual for instructions and safety precautions before operating this equipment.

The information and instructions given in this manual do not amend or extend the limited warranties for the equipment given at the time of purchase.

Refer to the manufacturer's manual for maintenance intervals and procedures unless otherwise instructed in this manual. Follow the manufacturer's recommendations for dusty conditions.

NOTICE This manual only provides information about additional procedures or procedures to be performed at different time intervals than found in the manufacturer's manuals. Refer to the manufacturer's manual for complete maintenance instructions.



WARNING! Clean sawdust from all guards, vents, control boxes, or any area where sawdust may gather **after every shift**. Failure to do so may result in fire, causing death or serious injury.

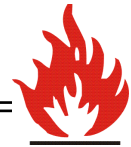

1.1 Safety

Use caution when performing maintenance or service to the engine.



DANGER! Take proper protective measures against rotating shafts, pulleys, fans, etc.

Ensure loose clothing or long hair does not engage rotating members.

DANGER! Do not touch or perform service functions on a hot engine. Allow the engine to cool sufficiently before beginning any service function. Hot engine components will cause serious burns.



WARNING! Remove the blade before performing any engine service.

WARNING! Wear eye, hand, and foot protection equipment when performing service functions.

SECTION 2 OPERATION

2.1 Starting The Engine



DANGER! Ensure the blade is disengaged and all persons are out of the path of the blade before starting. Failure to do so will result in death or serious injury.

DANGER! Operate your engine only in well ventilated areas. The exhaust gases of your engine can cause nausea, delirium, and potentially death unless adequate ventilation is present.

DANGER! Never operate an engine with a fuel or oil leak. This is a fire hazard, which may cause serious injury or death.



WARNING! Do not operate engine without proper and operational spark arrester/muffler. Sparks emitted from the engine exhaust could ignite surrounding materials, causing serious injury or death.



CAUTION! EPA Compliant Gas Tanks Only: Always relieve all fuel pressure inside the tank prior to filling or connecting fuel fittings. Failure to do so may result in fuel spillage.

CAUTION! EPA Compliant Gas Tanks Only: Disconnect the fuel tank when not in use, or engine flooding or fuel spillage may result.

1. Close the engine choke by moving the choke lever to the start position.
2. Turn the key switch to the START position and release.
3. Release the key switch to the RUN position after the engine starts.
4. When the engine starts, slowly open the choke all the way by moving the choke lever to the off position.

ENGINE SHUTOFF

1. Disengage the clutch handle to stop the blade if necessary.
2. Let the engine run for 15 seconds with no load, then turn the key switch to the OFF position.

SECTION 3 MAINTENANCE

Refer to the manufacturer's manual for maintenance intervals and procedures unless otherwise instructed in this manual. Follow the manufacturer's recommendations for dusty conditions.

NOTICE This manual only provides information about additional procedures or procedures to be performed at different time intervals than found in the manufacturer's manuals. Refer to the manufacturer's manual for complete maintenance instructions.



WARNING! Clean sawdust from all guards, vents, control boxes, or any area where sawdust may gather **after every shift**. Failure to do so may result in fire, causing death or serious injury.



3.1 Safety

Use caution when performing maintenance or service to the engine.



DANGER! Take proper protective measures against rotating shafts, pulleys, fans, etc.

Ensure loose clothing or long hair does not engage rotating members.

DANGER! Do not touch or perform service functions on a hot engine. Allow the engine to cool sufficiently before beginning any service function. Hot engine components will cause serious burns.



WARNING! Remove the blade before performing any engine service.

WARNING! Wear eye, hand, and foot protection equipment when performing service functions.

3.2 Cooling System

Wash the engine or brush off sawdust and debris every 50 hours of operation.

Clean the grass screen, cooling fins, and external surfaces.

Remove any dust, dirt, or oil.

See engine manual for further instructions.

3.3 Air Filter & Pre-Cleaner



WARNING! Always wear proper safety equipment when performing service functions, including eye protection, breathing protection, hand protection and foot protection.

Service the pre-cleaner every four hours of operation by gently shaking excess sawdust and debris from the foam piece.

Clean the air filter (air cleaner element) and pre-cleaner (element wrapper) every eight hours of operation.

Replace the air filter (cleaner) every 200 hours of operation.

Replace the pre-cleaner (element wrapper) every 2000 hours of operation.

See the engine manual for further instructions.

3.4 Fuel Filter

Replace the fuel filter every 100 hours of operation or as required for engine performance.

3.5 Battery

Check the battery electrolyte level every 50 hours of operation. See manufacturer's manual for instructions.

 **DANGER!** Batteries expel explosive gases.

Keep sparks, flames, burning cigarettes, or other ignition sources away at all times.

Wear a face shield when working on batteries.

 **WARNING!** Battery posts, terminals and related accessories contain lead and lead compounds. Wash hands after handling.

3.6 Miscellaneous Maintenance

Inspect the spark plugs every 100 hours of operation. Remove any deposits and adjust gap if necessary. See engine manual for further information.

Review the manufacturer's engine manual for maintenance intervals.

3.7 RPM Adjustments

 **WARNING!** Remove the blade before performing any engine service. Failure to do so may result in serious injury.

Check the RPM with a tachometer every 200 hours of operation.

Engine	High End RPM	Low End RPM
G15	3750	1800

Before checking the RPM, ensure belt and brake strap tensions are correct (See Sawmill Maintenance).

Check oil, fuel, and coolant levels.

Ensure the throttle cable does not affect the engine RPM when the clutch handle is disengaged. Make sure the cable is not bent or kinked.

1. Start the engine to measure the low-end RPM.
2. Refer to the engine manual to adjust the low-end RPM.
3. Engage the clutch handle to throttle the engine and measure the high-end RPM.

The high-end RPM is factory-set at 3750.

4. Readjust the throttle cable if necessary to increase or reduce the high-end engine speed.

SECTION 4 REPLACEMENT PARTS

4.1 Engine Assembly

LT15Rev. E1.00+

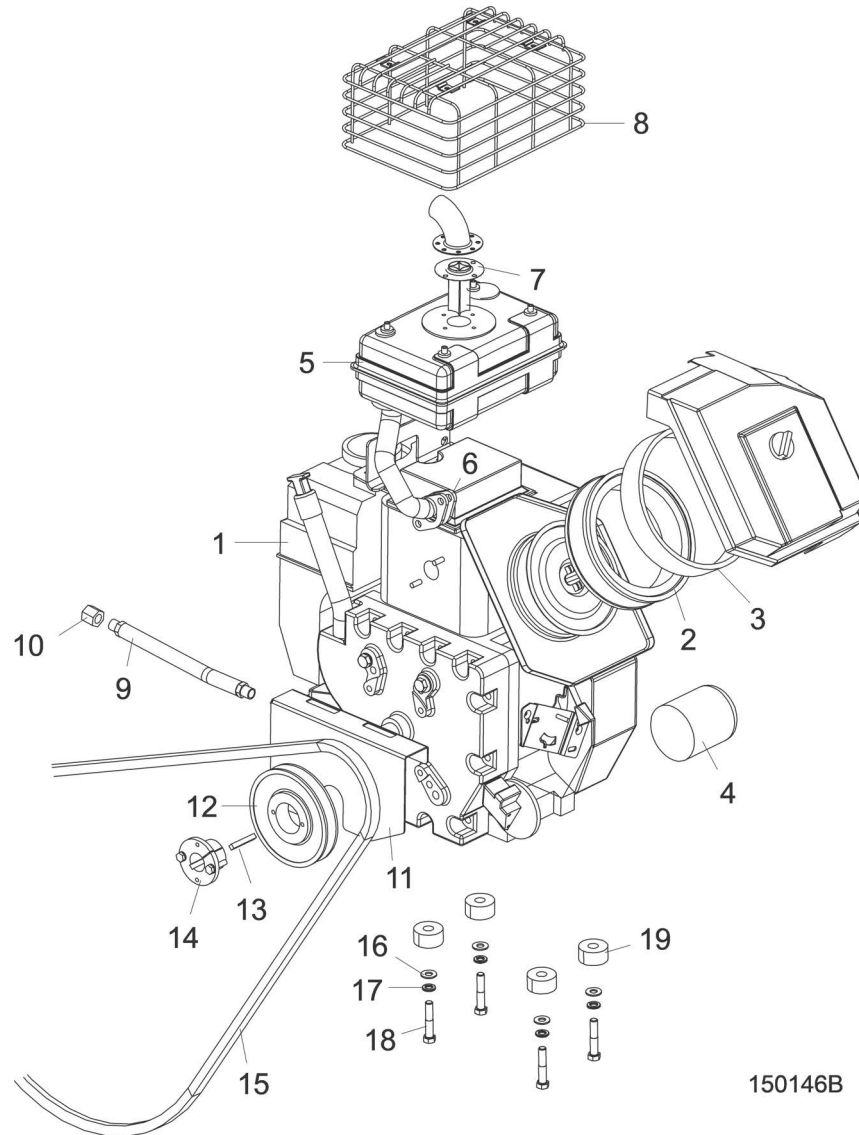

150146B

REF	PART #	DESCRIPTION	COMMENTS	QTY.
	P12393	Cover, Engine		1
	034804	ENGINE ASSEMBLY, 15 HP KOHLER W/CLUTCH & ELECTRIC START	G15 engine option no longer available (3/11). Use conversion kit 065379 for service on LT15 Rev. E4.00 and later. Kit includes G18 Kohler engine, drive wheel, drive belt, tray, reduction kit and belt tensioner gauge. NOTE: Conversion kit will not work on LT15 prior to Rev. E4.00.	1
1	033377	Engine, 15 HP Kohler #PH44528	Available in assemblies only.	1
2	014718	Filter, Kohler Air #47-083-01		1

REF	PART #	DESCRIPTION	COMMENTS	QTY.
3	014719	Pre-Cleaner, Kohler Air #52-083-01		1
4	014717	Filter, Kohler Oil #52-050-02		1
	061128	Muffler Assembly, G13/G15 Kohler w/Arrestor		1
5	061108	Muffler Kit, G15 Kohler #12-786-16-S	Available in assemblies only.	1
6	N/A	Gasket, Kohler Muffler		1
7	036684	Arrestor, Kohler Spark		1
8	061109	Cage, Muffler Kohler #12-314-32-S	016105 Square Muffler Cage no longer available (5/16). NOTE: Muffler Cage 061109 is a round cage and can be used only for engines equipped with the round muffler.	1
	P12757	Plug, Kohler Spark #12-132-02 (Champion #RC12YC)		1
	014720	Filter, Kohler In-Line Fuel #25-050-02		1
	051992	Switch, Kohler PHI Oil #25-099-24-S		1
	038425	Solenoid, Kohler Starter #25-435-02-S		1
	038426	Bypass Kit, Kohler Oil PSI #82-755-25-S		1
		Throttle and Clutch Parts	See Section 4.5	
9	P10082	Hose, Oil Drain		1
10	P04332	Cap, Oil Drain Hose		1
11	016493	Plate, LT15 Engine Guard		1
12	016512	Sheave, BK55QT		1
13	S04124	Key, 1/4" X 1 11/16"	Replaces S21486 1/4" x 1" key. S04124 always used in production.	1
14	016513	Bushing, QT x 1		1
	024718	Harness Assembly, Battery To Engine		1
15	017943	BELT, BX87 DRIVE		1
16	F05011-3	WASHER, 3/8" SAE FLAT		4
17	F05011-4	WASHER, 3/8" SPLIT LOCK		4
18	F05007-124	BOLT, 3/8-16 X 2 HEX HEAD GR5		4
19	034641	Spacer, 17/32 x 1 1/2 x 3/4		4

4.2 Engine Assembly

LT15Rev. D4.00 - D7.00

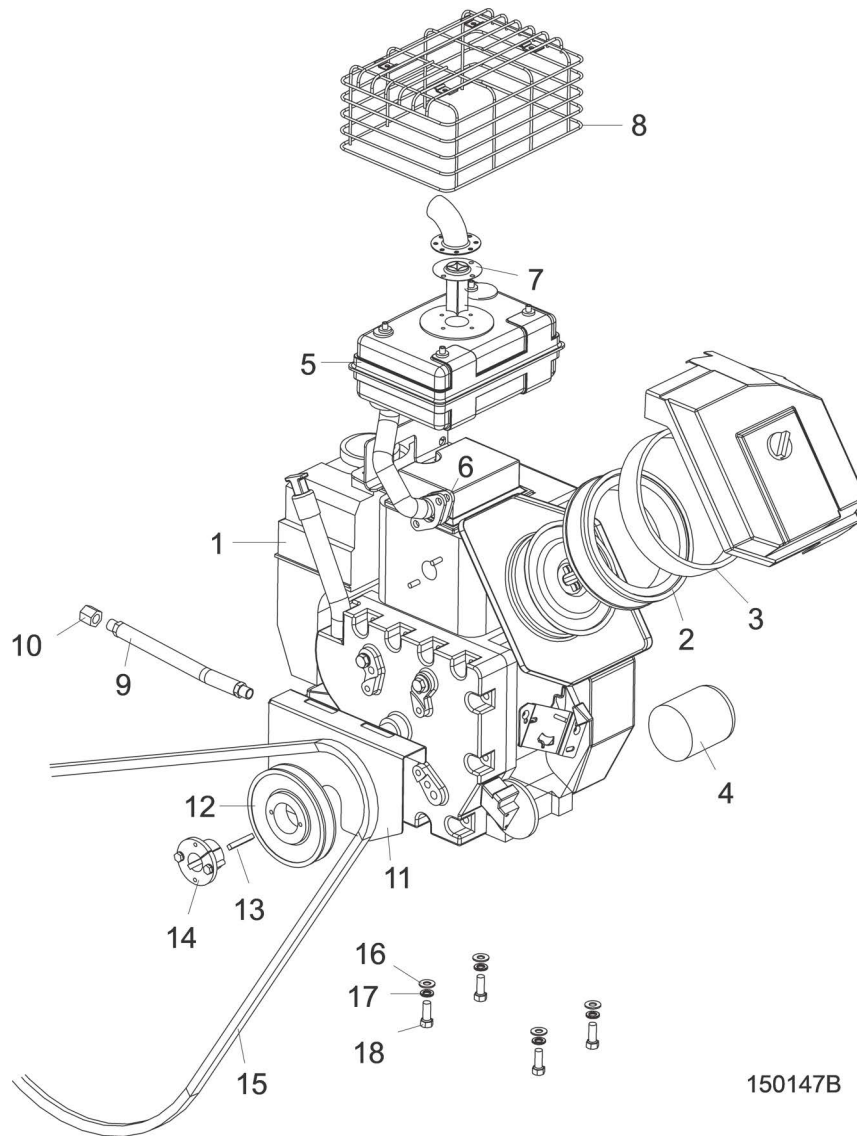

150147B

REF	PART #	DESCRIPTION	COMMENTS	QTY.
	P12393	Cover, Engine		1
	016504	ENGINE ASSY, 15 HP KOHLER W/CLUTCH & ELECTRIC START	G15 engine option no longer available (3/11). Use conversion kit 065379 for service on LT15 Rev. E4.00 and later. Kit includes G18 Kohler engine, drive wheel, drive belt, tray, reduction kit and belt tensioner gauge. NOTE: Conversion kit will not work on LT15 prior to Rev. E4.00.	1
1	033377	Engine, 15 HP Kohler #PH44528	Available in assemblies only.	1
2	014718	Filter, Kohler Air #47-083-01		1
3	014719	Pre-Cleaner, Kohler Air #52-083-01		1
4	014717	Filter, Kohler Oil #52-050-02		1

REF	PART #	DESCRIPTION	COMMENTS	QTY.
5	061108	Muffler Kit, G15 Kohler #12-786-16-S		1
6	N/A	Gasket, Kohler Muffler		1
7	036684	Arrestor, Kohler Spark (Required w/Muffler)		1
8	061109	Cage, Muffler Kohler #12-314-32-S (Required w/Muffler #061108)	016105 Square Muffler Cage no longer available (5/16). NOTE: Muffler Cage 061109 is a round cage and can be used only for new engines equipped with the round muffler.	1
	P12757	Plug, Kohler Spark #12-132-02 (Champion #RC12YC)		1
	014720	Filter, Kohler In-Line Fuel #25-050-02		1
	051992	Switch, Kohler PHI Oil #25-099-24-S		1
	038425	Solenoid, Kohler Starter #25-435-02-S		1
	038426	Bypass Kit, Kohler Oil PSI #82-755-25-S		1
		Throttle and Clutch Parts	See Section 4.5	
9	P10082	Hose, Oil Drain		1
10	P04332	Cap, Oil Drain Hose		1
11	016493	Plate, LT15 Engine Guard		1
12	016512	Sheave, BK55QT		1
13	S04124	Key, 1/4" x 1 11/16"		1
14	016513	Bushing, QT x 1		1
	024718	Harness Assembly, Battery To Engine		1
15	016505	BELT, BX82 DRIVE		1
16	016473	Plate, LT15 Motor Mount		1
17	F05011-3	WASHER, 3/8" SAE FLAT		4
18	F05011-4	WASHER, 3/8" SPLIT LOCK		4
19	F05007-7	BOLT, 3/8-16 X 1" HEX HEAD		4

4.3 Engine Assembly

LT15Rev. D2.00 - D3.00

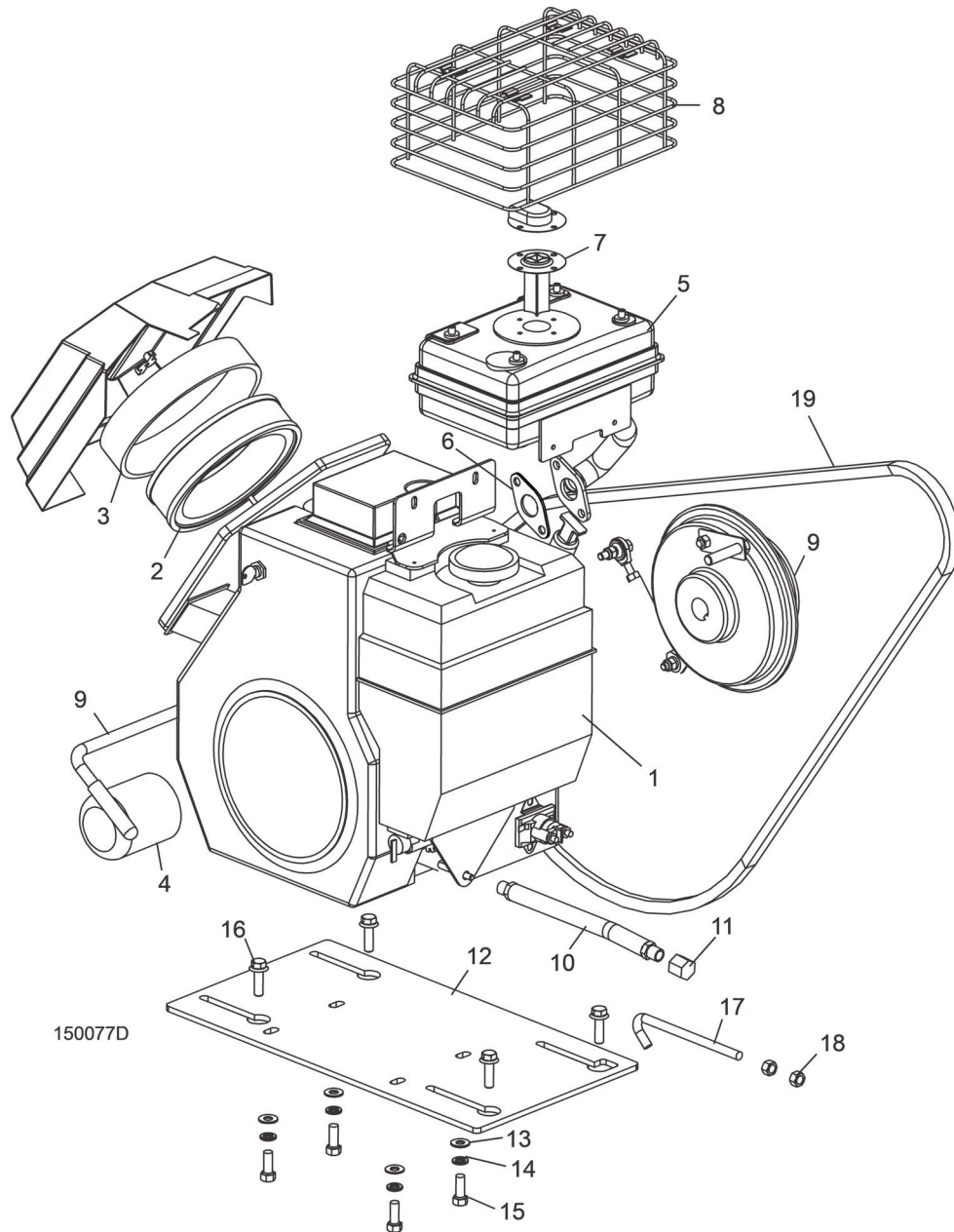

REF	PART #	DESCRIPTION	COMMENTS	QTY.
	P12393	Cover, Engine		1
	016416	ENGINE ASSY, 15 HP KOHLER W/CLUTCH & ELECTRIC START		1
1	033377	Engine, 15 HP Kohler #PH44528	Available in assemblies only.	1
2	014718	Filter, Kohler Air #47-083-01		1
3	014719	Pre-Cleaner, Kohler Air #52-083-01		1
4	014717	Filter, Kohler Oil #52-050-02		1
5	061108	Muffler Kit, G15 Kohler #12-786-16-S		1
6	N/A	Gasket, Kohler Muffler		1

REF	PART #	DESCRIPTION	COMMENTS	QTY.
7	036684	Arrestor, Kohler Spark (Required w/Muffler)		1
8	061109	Cage, Muffler Kohler #12-314-32-S (Required w/Muffler #061108)	016105 Square Muffler Cage no longer available (5/16). NOTE: Muffler Cage 061109 is a round cage and can be used only for new engines equipped with the round muffler.	1
	P12757	Plug, Kohler Spark #12-132-02 (Champion #RC12YC)		1
	014720	Filter, Kohler In-Line Fuel #25-050-02		1
	051992	Switch, Kohler PHI Oil #25-099-24-S		1
	038425	Solenoid, Kohler Starter #25-435-02-S		1
	038426	Bypass Kit, Kohler Oil PSI #82-755-25-S		1
9		Throttle and Clutch Parts (See Section 4.5)		
10	P10082	Hose, Oil Drain		1
11	P04332	Cap, Oil Drain Hose		1
12	014810	Plate, G13/G15 Engine Mount		1
13	F05011-3	Washer, 3/8" SAE Flat		4
14	F05011-4	Washer, 3/8" Split Lock		6
15	F05007-7	Bolt, 3/8-16 x 1" Hex Head		4
	024718	Harness Assembly, Battery To Engine		1
16	F05007-131	BOLT, 3/8-16 X 1 1/4" SPRING WASHER LOCK HEX HEAD		4
17	014975	ROD, BELT TENSION ADJUSTMENT		1
18	F05010-1	NUT, 3/8-16 HEX		2
19	014819	BELT, BX81		1

4.4 Throttle/Clutch Assembly

LT15 G13/G15Rev. E1.00 - E6.09

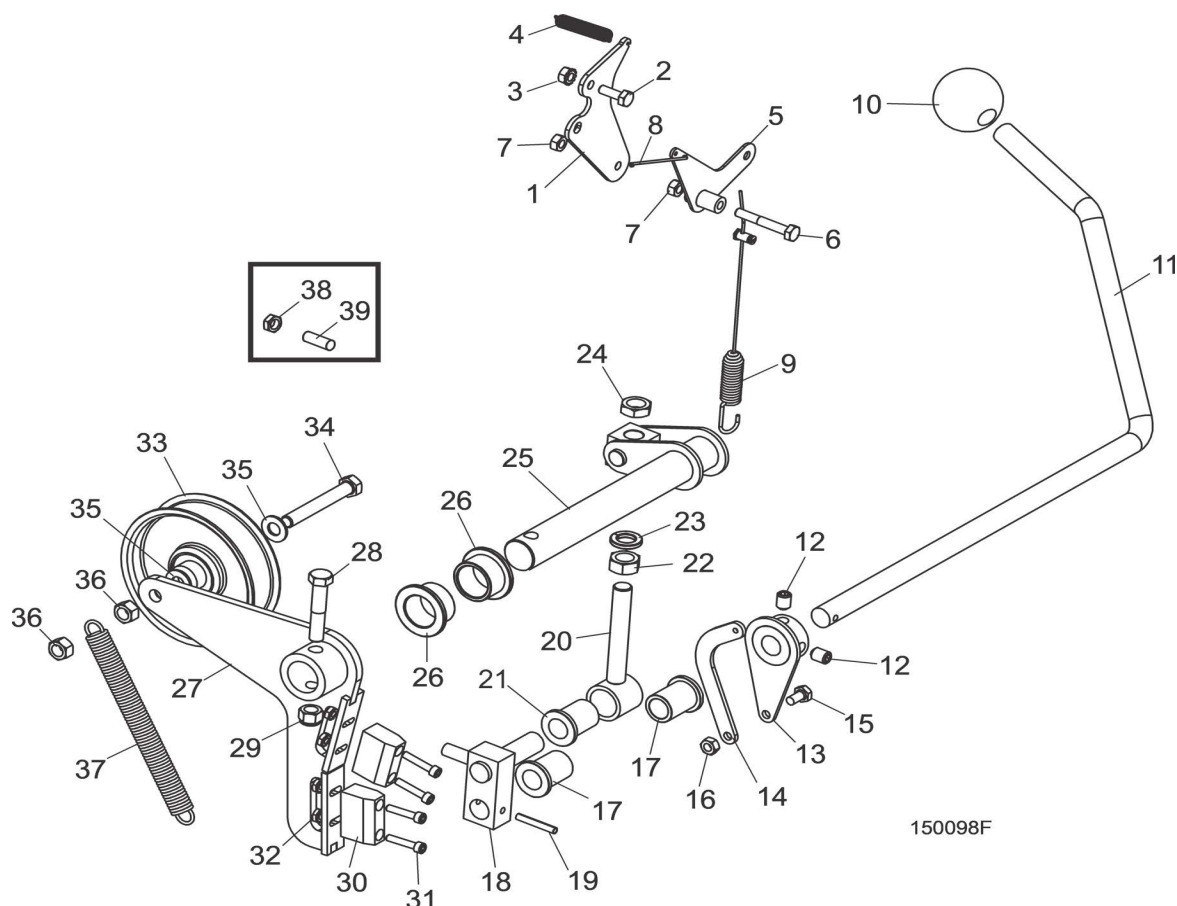

REF	PART #	DESCRIPTION	COMMENTS	QTY.
1	034616	PLATE, THROTTLE CABLE BRACKET LT15G		1
2	F05005-1	SCREW, 1/4-20 X 3/4 FT HEX HEAD		1
3	F05010-69	NUT, 1/4-20 NYLON LOCK		1
4	014818	SPRING, EXTENSION 3/8 X 3		1
5	034805	PIVOT WELDMENT, THROTTLE LT15G		1
6	F05005-125	BOLT, 1/4-20 X 2 HEX HEAD GR5		1
7	F05010-21	NUT, 1/4-20 SWAGED		2
8	015446	LINK, THROTTLE 2 13/16		1
9	034838	CABLE ASSEMBLY, LT15G15 THROTTLE		1
10	P04211	KNOB, 5/8-11 BALL		1
11	016487	HANDLE, LT15 CLUTCH		1
12	F05007-12	SCREW, 3/8-16 X 1/2 SOCKET HEAD CUP PT SET		2
13	034815	ACTUATOR WELDMENT, THROTTLE LT15D&G		1
14	034818	LINKAGE, THROTTLE LT15D&G		1
15	F05005-15	BOLT, 1/4-20 X 1/2" HEX HEAD		1
16	F05010-21	NUT, 1/4-20 SWAGED		1
17	016486	BUSHING, 5/8" ID X 7/8" OD X 1 1/8" LONG FLANGED BRONZE		2

REF	PART #	DESCRIPTION	COMMENTS	QTY.
18	034612	BLOCK WELDMENT, LINKAGE CLUTCH/BRAKE		1
19	F05012-16	PIN, 3/16 X 1 1/4 ROLL		1
20	034605	LINKAGE ASSEMBLY, W/BEARING		1
21	016486	Bushing, 5/8" ID x 7/8" OD x 1 1/8" Long Flanged Bronze		1
22	F05010-35	NUT, 1/2-13 FREE HEX, ZINC		1
23	F05011-9	WASHER, 1/2 SPLIT LOCK		1
24	F05010-31	NUT, 1/2-13 JAM		1
25	034608	PIVOT WELDMENT, CLUTCH/BRAKE		1
26	P737	BUSHING, 1 X 1 1/4 X 3/4 FLG BRONZE		2
	034603	BRAKE/CLUTCH ASSEMBLY, LT15		1
27	034613	Arm Weldment, Clutch/Brake LT15		1
28	F05007-124	Bolt, 3/8-16 x 2 Hex Head Gr5		1
29	F05010-10	Nut, 3/8-16 Hex Nylon Lock		1
30	016488	Block, LT15 Brake		2
31	F05004-2	Screw, 10-24 x 1" Socket Head	Replaces F05004-50 originally supplied before 4/03 (duplicate part numbers).	4
32	F05010-14	Nut, #10-24 Keps		4
33	034602	Idler, 4" O.D. x 3/8 Bore		1
34	F05007-230	Bolt, 3/8-16 x 2-3/4" Hex Head Gr5 Full Thread		1
35	F05011-3	Washer, 3/8 Flat		2
36	F05010-25	Nut, 3/8-16 Swaged Lock		2
37	034810	Spring, Idler Arm LT15/D/E/G		1

4.5 Throttle/Clutch Assembly

LT15 Rev. D4.00 - D7.00

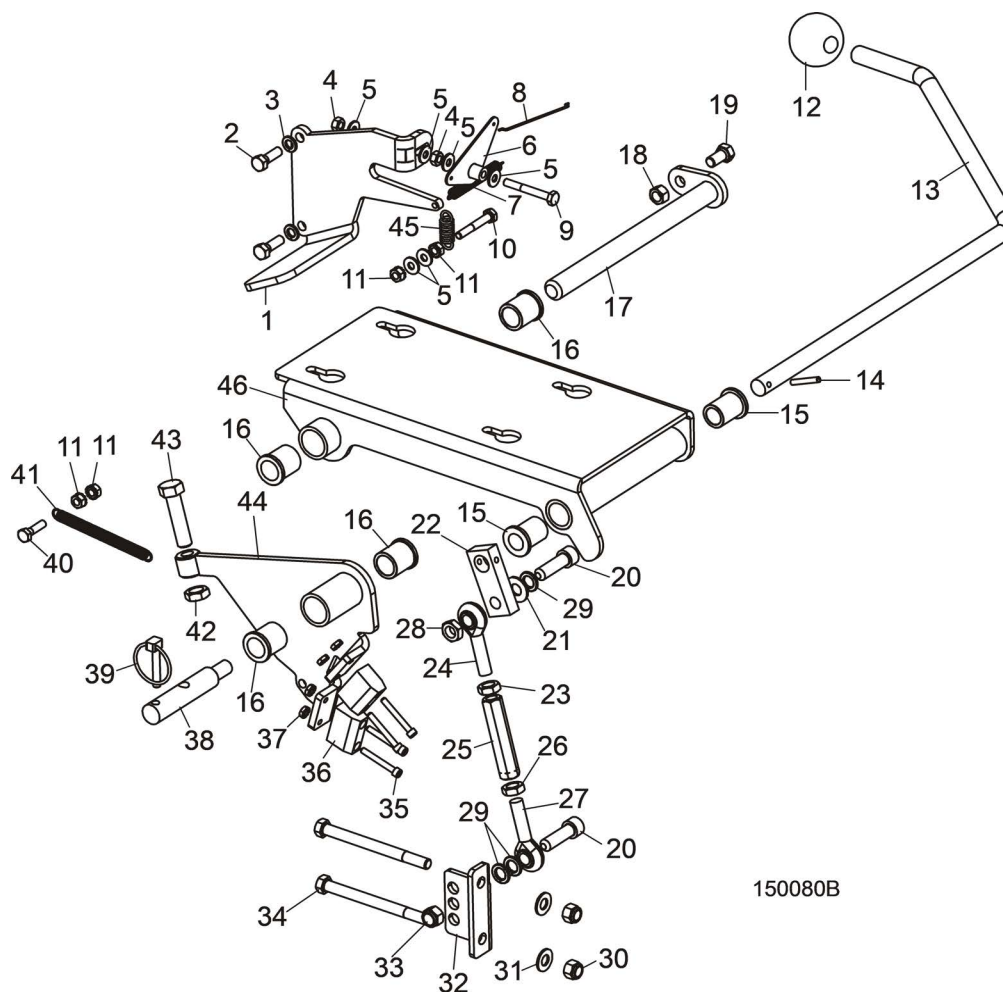

150080B

REF	PART #	DESCRIPTION	COMMENTS	QTY.
1	016470	PLATE, BRAKE ACTUATOR		1
2	F05006-11	BOLT, 5/16-24 X 1" HEX HEAD		2
3	F05011-13	WASHER, 5/16" SPLIT LOCK		2
4	F05010-21	NUT, 1/4-20 SWAGED		2
5	F05011-11	WASHER, 1/4" SAE FLAT		6
6	016503	PIVOT WELDMENT, THROTTLE LT15		1
7	014818	SPRING, 3/8" X 3" EXTENSION		1
8	014826	WIRE, THROTTLE LT15		1
9	F05005-125	BOLT, 1/4-20 X 2" HEX HEAD GRADE 5		1
10	F05005-4	SCREW, 1/4-20 X 1 3/4" HEX HEAD CAP		1
11	F05010-9	NUT, 1/4-20 KEPS		2
12	P04211	KNOB, 5/8-18 PLASTIC ROUND		1
13	016487	HANDLE, LT15 CLUTCH	Clutch Handle 016487 modified 3/07 to eliminate possible pinch point with feed rope pulley with saw head at certain heights.	1
14	F05012-16	PIN, 3/16 X 1 1/4" ROLL		1

REF	PART #	DESCRIPTION	COMMENTS	QTY.
15	016486	BUSHING, 5/8" ID X 7/8" OD X 1 1/4" LONG FLANGED BRONZE		2
16	016485	BUSHING, 3/4" ID X 1" OD X 1 1/8" LONG FLANGED BRONZE		4
17	016477	PIN WELDMENT, MOTOR PIVOT		1
18	F05010-25	NUT, 3/8-16 SWAGED LOCK		1
19	F05007-27	BOLT, 3/8-16 X 3/4" HEX HEAD GRADE 2		1
20	F05007-55	SCREW, 7/16-20 X 1 1/2" SOCKET HEAD CAP		2
21	F05011-43	WASHER, 7/16" SAE FLAT 15/16" OD		1
22	016481	BLOCK, MOTOR HANDLE PIVOT		1
	A12304	TURNBUCKLE ASSEMBLY, CLUTCH		1
23	F05010-38	Nut, 7/16-20 Jam		1
24	P11579	Rod End, 7/16-20 Right Hand Male		1
25	S11577	Turnbuckle, 3" Clutch		1
26	F05010-87	Nut, 7/16-20 Left Hand Jam		1
27	P11578	Rod End, 7/16-20 Left Hand Male		1
28	F05010-38	NUT, 7/16-20 JAM		1
29	F05011-48	WASHER, 7/16" SPLIT LOCK		3
30	F05010-10	NUT, 3/8-16 HEX NYLON LOCK		2
31	F05011-3	WASHER, 3/8" FLAT SAE		6
32	016472	PLATE, LOWER TURNBUCKLE MOUNT		1
33	F05010-83	NUT, 7/16-20 NYLON LOCK		1
34	F05007-35	BOLT, 3/8-16 X 4 1/2" HEX HEAD		2
35	F05004-51	SCREW, 10-24 X 1 1/2" SOCKET HEAD CAP BLACK OXIDE		4
36	016488	BLOCK, LT15 BRAKE		2
37	F05010-14	NUT, #10-24 KEPS		4
38	040102	PIN, IDLER PIVOT		1
39	P113	PIN, 1/4" DIA LYNCH		1
40	F05005-38	SCREW, 1/4-20 X 1" HEX HEAD CAP		1
41	016508	SPRING, 3/8" OD X 4 1/2" LONG X .047" WIRE EXTENSION		1
42	F05010-31	NUT, 1/2-13 JAM		1
43	F05008-8	BOLT, 1/2-13 X 2" HEX HEAD GRADE 5	Replaces F05008-33 1/2-13 x 1 1/2" Hex Head Bolt supplied prior to 10/00. Longer bolt pro- vides more brake adjustment.	1
44	016482	PLATE WELDMENT, BRAKE		1
45	014817	SPRING, EXTENSION 1/2" X 2 1/4" X .06"		1
46	016473	PLATE, LT15 MOTOR MOUNT		1

4.6 Throttle/Clutch Assembly

LT15Rev. D3.00

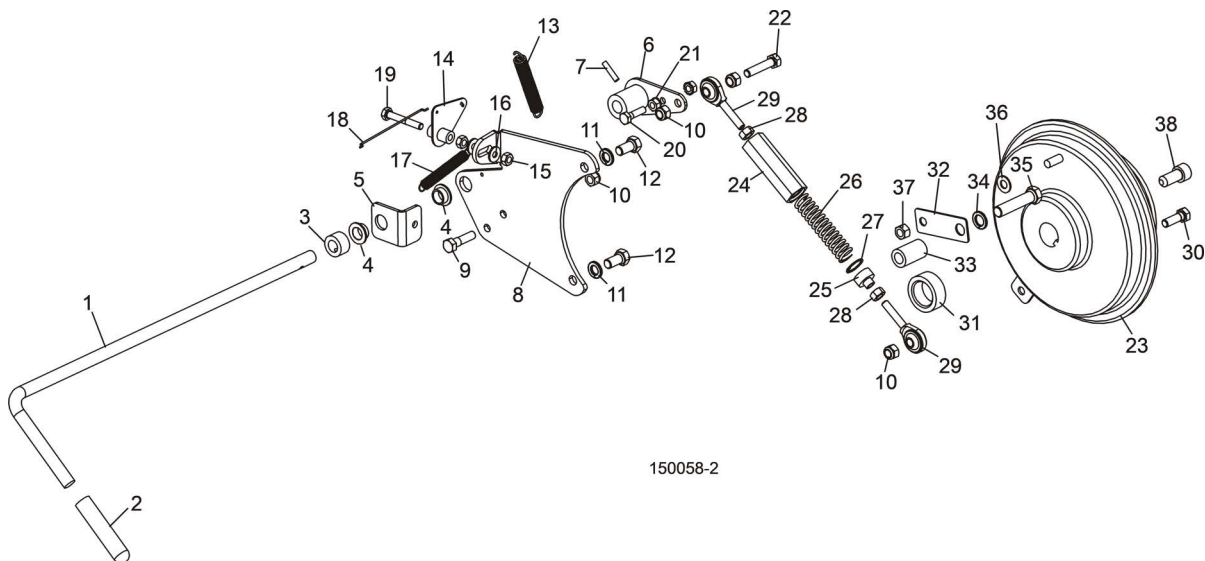

150058-2

REF	PART #	DESCRIPTION	COMMENTS	QTY.
1	014825	HANDLE, THROTTLE/CLUTCH		1
2	014835	GRIP, 1/2" I.D. X 3" LONG HANDLE		1
3	014820	COLLAR, 1/2" I.D. X 7/8" O.D. LOCK		1
4	P08060	BUSHING, SF1260-6 BRONZE		2
5	014821	BRACKET, THROTTLE/CLUTCH HANDLE MOUNT		1
6	014837	BRACKET, THROTTLE/CLUTCH HANDLE PIVOT		1
7	F05012-22	PIN, 3/16" X 5/8" ROLL		1
8	014813	PLATE, THROTTLE MOUNT		1
9	F05006-18	BOLT, 5/16-18 X 1 1/4" HEX HEAD FULL THREAD		1
10	F05010-58	NUT, 5/16-18 HEX NYLON LOCK		4
11	F05011-4	WASHER, 3/8" SPLIT LOCK		2
12	F05007-27	BOLT, 3/8-16 X 3/4" HEX HEAD GRADE 2		2
13	014817	SPRING, 1/2" X 2 1/4" X .06" EXTENSION		1
14	014836	BRACKET WELDMENT, THROTTLE PIVOT		1
15	F05010-21	NUT, 1/4-20 HEX LOCK		2
16	F05011-11	WASHER, 1/4" SAE FLAT		2
17	014818	SPRING, 3/8" X 3" EXTENSION		1
18	014826	WIRE, THROTTLE		1
19	F05005-4	BOLT, 1/4-20 X 1 3/4" HEX HEAD GRADE 2		1
20	F05005-38	BOLT, 1/4-20 X 1" HEX HEAD GRADE 2		1
21	F05010-9	NUT, 1/4-20 SELF-LOCKING HEX		2
22	F05006-76	BOLT, 5/16-18 X 1 1/2" HEX HEAD GRADE 5 FULL THREAD		1
	016514	CLUTCH/TURNBUCKLE KIT, LT15 SPRING-LOADED	Kit includes Clutch and Spring-Loaded Turnbuckle. Use to retrofit LT15 prior to Rev. D3.00.	1

REF	PART #	DESCRIPTION	COMMENTS	QTY.
23	014816	Clutch, LT15 w/Brake	Available in assemblies only. Kit includes Clutch and Spring-Loaded Turnbuckle. Use to retrofit LT15 prior to Rev. D3.00.	1
	016446	Turnbuckle Assembly, LT15 Spring-Loaded Clutch		1
24	016443	Turnbuckle, LT15 Clutch	Available in assemblies only.	1
25	016444	Plunger, LT15 Clutch Turnbuckle		1
26	016492	Spring, 3/4" OD x 3" Long x .095" Wire Compression		1
27	F04254-34	Ring, 3/4" Inside Retaining		1
28	F05010-28	Nut, 5/16-24 Hex		2
29	P09814	Rod End, 5/16-24 Male Right-Hand		2
	016446-956	Instruction Sheet, LT15 Clutch Turnbuckle Installation		1
	016514-957	Instruction Sheet, LT15 Clutch Installation		1
30	F05006-1	BOLT, 5/16-18 X 1" HEX HEAD GRADE 2		1
31	S09174	SPACER, 1.016" X 1.5" X .56"		1
	016437	BRACKET KIT, LT15G13 RETRO CLUTCH MOUNT		1
32	015979	Bracket, Clutch Mount		1
33	015978	Boss, 3/4 x 29/64 x 1 1/4"		1
34	F05011-48	Washer, 7/16" Split Lock		1
35	F05007-139	Bolt, 7/16-14 x 2" Hex Head Grade 5		1
36	F05011-17	WASHER, 5/16" SAE FLAT		1
37	F05010-6	NUT, 5/16-18 HEX LOCK		1
38	F05007-117	BOLT, 7/16-20 X 1" SOCKET HEAD		1

4.7 Throttle/Clutch Assembly

LT15Rev. A1.00 - D2.00

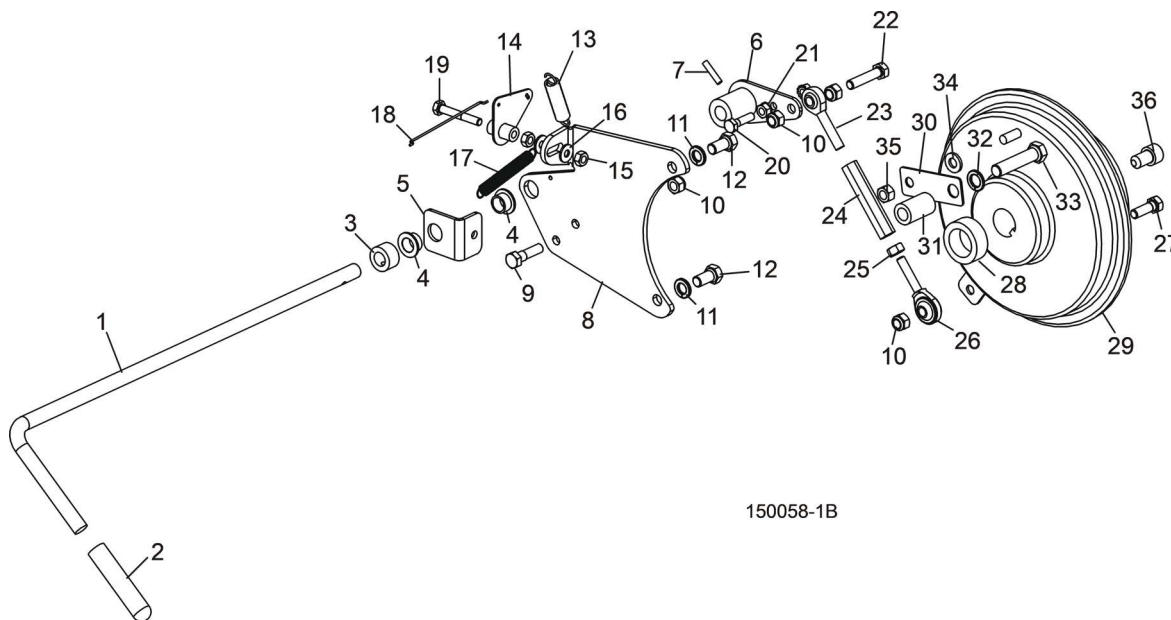

150058-1B

REF	PART #	DESCRIPTION	COMMENTS	QTY.
1	014825	HANDLE, THROTTLE/CLUTCH		1
2	014835	GRIP, 1/2" I.D. X 3" LONG HANDLE		1
3	014820	COLLAR, 1/2" I.D. X 7/8" O.D. LOCK		1
4	P08060	BUSHING, SF1260-6 BRONZE		2
5	014821	BRACKET, THROTTLE/CLUTCH HANDLE MOUNT		1
6	014837	BRACKET, THROTTLE/CLUTCH HANDLE PIVOT		1
7	F05012-22	PIN, 3/16" X 5/8" ROLL		1
8	014813	PLATE, THROTTLE MOUNT		1
9	F05006-18	BOLT, 5/16-18 X 1 1/4" HEX HEAD FULL THREAD		1
10	F05010-58	NUT, 5/16-18 HEX NYLON LOCK		4
11	F05011-4	WASHER, 3/8" SPLIT LOCK		2
12	F05007-27	BOLT, 3/8-16 X 3/4" HEX HEAD GRADE 2		2
13	014817	SPRING, 1/2" X 2 1/4" X .06" EXTENSION		1
14	014836	BRACKET WELDMENT, THROTTLE PIVOT		1
15	F05010-21	NUT, 1/4-20 HEX LOCK		2
16	F05011-11	WASHER, 1/4" SAE FLAT		2
17	014818	SPRING, 3/8" X 3" EXTENSION		1
18	014826	WIRE, THROTTLE		1
19	F05005-4	BOLT, 1/4-20 X 1 3/4" HEX HEAD GRADE 2		1
20	F05005-38	BOLT, 1/4-20 X 1" HEX HEAD GRADE 2		1
21	F05010-9	NUT, 1/4-20 SELF-LOCKING HEX		2
22	F05006-76	BOLT, 5/16-18 X 1 1/2" HEX HEAD GRADE 5 FULL THREAD		1

REF	PART #	DESCRIPTION	COMMENTS	QTY.
	014934	TURNBUCKLE ASSEMBLY, LT15 CLUTCH	Available in assemblies only. Turnbuckle retrofit 016446 available 3/00 (See Section 4.7). Spring-loaded turnbuckle improves durability of the clutch and is easier to adjust.	1
23	014815	Rod End, 5/16-24 Male Left-Hand		1
24	014880	Turnbuckle, 2 3/4" Clutch		1
25	F05010-28	Nut, 5/16-24 Hex		1
26	P09814	Rod End, 5/16-24 Male Right-Hand	Replaces 014814 supplied before 5/98 (duplicate parts).	1
27	F05006-1	BOLT, 5/16-18 X 1" HEX HEAD GRADE 2		1
28	S09174	SPACER, 1.016" X 1.5" X .56"		1
29	014816	CLUTCH, LT15 W/BRAKE	Available in assemblies only. Clutch available only in kit 016514 including spring-loaded turnbuckle (See Section 4.7).	1
	016437	BRACKET KIT, LT15G13 RETRO CLUTCH MOUNT		1
30	015979	Bracket, Clutch Mount		1
31	015978	Boss, 3/4 x 29/64 x 1 1/4"		1
32	F05011-48	Washer, 7/16" Split Lock		1
33	F05007-139	Bolt, 7/16-14 x 2" Hex Head Grade 5		1
34	F05011-17	WASHER, 5/16" SAE FLAT		1
35	F05010-6	NUT, 5/16-18 HEX LOCK		1
36	F05007-117	BOLT, 7/16-20 X 1" SOCKET HEAD		1