

G14 Engine

**Safety, Operation, Maintenance
& Parts Manual**

110052 Engine, LT15G14 Start **rev. A**

Safety is our #1 concern!

Form #2306

**Used with
LT15G14S**

rev. A1.00 - A1.04



WARNING! Read and understand this manual before using this machine.

California
Proposition 65 Warning



WARNING: Breathing gas/diesel engine exhaust exposes you to chemicals known to the State of California to cause cancer and birth defects or other reproductive harm.

Always start and operate the engine in a well-ventilated area.
If in an enclosed area, vent the exhaust to the outside.
Do not modify or tamper with the exhaust system.
Do not idle the engine except as necessary.

For more information go to **www.P65warnings.ca.gov**.



WARNING: Drilling, sawing, sanding or machining wood products can expose you to wood dust, a substance known to the State of California to cause cancer. Avoid inhaling wood dust or use a dust mask or other safeguards for personal protection.

For more information go to **www.P65Warnings.ca.gov/wood**.

Active Patents assigned to Wood-Mizer, LLC

Wood-Mizer, LLC has received patents that protect our inventions which are a result of a dedication to research, innovation, development, and design. Learn more at: woodmizer.com/patents

©2023 Wood-Mizer LLC

Printed in the United States of America, all rights reserved. No part of this manual may be reproduced in any form by any photographic, electronic, mechanical or other means or used in any information storage and retrieval system without written permission from

Wood-Mizer, LLC
8180 West 10th Street
Indianapolis, Indiana 46214

SECTION 1 SAFETY

1.1 Safety 1-1

SECTION 2 OPERATION

2.1 Starting The Engine 2-1

SECTION 3 MAINTENANCE

3.1 Safety 3-1
3.2 Cooling System 3-1
3.3 Air Filter & Pre-Cleaner 3-1
3.4 Fuel Filter 3-1
3.5 Miscellaneous Maintenance 3-1

SECTION 4 REPLACEMENT PARTS

4.1 Engine Assembly 4-1
4.2 Clutch Assembly 4-3

SECTION 1 SAFETY

This manual is provided as a supplement to the equipment manufacturer's manuals.

This manual provides information specific to the use of this equipment on the Wood-Mizer® sawmill. Refer to the sawmill operator's manual and manufacturer's manual before attempting to operate this equipment.

NOTICE Read the sawmill operator's manual and engine manufacturer's manual for instructions and safety precautions before operating this equipment.

The information and instructions given in this manual do not amend or extend the limited warranties for the equipment given at the time of purchase.

Refer to the manufacturer's manual for maintenance intervals and procedures unless otherwise instructed in this manual. Follow the manufacturer's recommendations for dusty conditions.

NOTICE This manual only provides information about additional procedures or procedures to be performed at different time intervals than found in the manufacturer's manuals. Refer to the manufacturer's manual for complete maintenance instructions.

 **WARNING!** Clean sawdust from all guards, vents, control boxes, or any area where sawdust may gather **after every shift**. Failure to do so may result in fire, causing death or serious injury.



1.1 Safety

Use caution when performing maintenance or service to the engine.

 **DANGER!** Take proper protective measures against rotating shafts, pulleys, fans, etc.
Ensure loose clothing or long hair does not engage rotating members.

DANGER! Do not touch or perform service functions on a hot engine. Allow the engine to cool sufficiently before beginning any service function. Hot engine components will cause serious burns.

 **WARNING!** Remove the blade before performing any engine service.

WARNING! Wear eye, hand, and foot protection equipment when performing service functions.

SECTION 2 OPERATION

2.1 Starting The Engine

 **DANGER!** Ensure the blade is disengaged and all persons are out of the path of the blade before starting. Failure to do so will result in death or serious injury.

DANGER! Operate your engine only in well ventilated areas. The exhaust gases of your engine can cause nausea, delirium, and potentially death unless adequate ventilation is present.

DANGER! Never operate an engine with a fuel or oil leak. This is a fire hazard, which may cause serious injury or death.

 **WARNING!** Do not operate engine without proper and operational spark arrester/muffler. Sparks emitted from the engine exhaust could ignite surrounding materials, causing serious injury or death.

 **CAUTION!** EPA Compliant Gas Tanks Only: Always relieve all fuel pressure inside the tank prior to filling or connecting fuel fittings. Failure to do so may result in fuel spillage.

CAUTION! EPA Compliant Gas Tanks Only: Disconnect the fuel tank when not in use, or engine flooding or fuel spillage may result.

1. Turn fuel shut-off valve to ON position
2. Turn engine on/off switch to ON position
3. Start engine as follows:

COLD ENGINE:

- a. Place throttle control midway between SLOW and FAST positions.
- b. Place choke control into ON position.

WARM ENGINE:

- a. Place throttle control midway between SLOW and FAST positions.
- b. Return choke to OFF position as soon as engine starts.

A warm engine usually does not require choke on.

4. Slowly pull starter handle until just past compression-STOP! Return starter handle; firmly pull straight out to avoid excessive rope wear from starter rope guide.
5. Gradually return choke control to OFF position after engine starts and warms up. Engine/equipment may be operated during warm up period, but it may be necessary to leave choke partially on until engine warms up.

For more information, see the engine manufacturer's operation manual.

ENGINE SHUTOFF

1. Disengage the clutch handle to stop the blade if necessary.
2. Move the throttle control to slow or idle position. Stop the engine.
3. Close the fuel shut-off valve.

SECTION 3 MAINTENANCE

Refer to the manufacturer's manual for maintenance intervals and procedures unless otherwise instructed in this manual. Follow the manufacturer's recommendations for dusty conditions.

NOTICE This manual only provides information about additional procedures or procedures to be performed at different time intervals than found in the manufacturer's manuals. Refer to the manufacturer's manual for complete maintenance instructions.



WARNING! Clean sawdust from all guards, vents, control boxes, or any area where sawdust may gather **after every shift**. Failure to do so may result in fire, causing death or serious injury.



3.1 Safety

Use caution when performing maintenance or service to the engine.



DANGER! Take proper protective measures against rotating shafts, pulleys, fans, etc.

Ensure loose clothing or long hair does not engage rotating members.

DANGER! Do not touch or perform service functions on a hot engine. Allow the engine to cool sufficiently before beginning any service function. Hot engine components will cause serious burns.



WARNING! Remove the blade before performing any engine service.

WARNING! Wear eye, hand, and foot protection equipment when performing service functions.

3.2 Cooling System

Wash the engine or brush off sawdust and debris every 50 hours of operation.

Clean the grass screen, cooling fins, and external surfaces.

Remove any dust, dirt, or oil.

See engine manual for further instructions.

3.3 Air Filter & Pre-Cleaner



WARNING! Always wear proper safety equipment when performing service functions, including eye protection, breathing protection, hand protection and foot protection.

Service the pre-cleaner every four hours of operation by gently shaking excess sawdust and debris from the foam piece.

Clean the air filter (air cleaner element) and pre-cleaner (element wrapper) every eight hours of operation.

Replace the air filter (cleaner) every 200 hours of operation.

Replace the pre-cleaner (element wrapper) every 2000 hours of operation.

See the engine manual for further instructions.

3.4 Fuel Filter

Replace the fuel filter every 100 hours of operation or as required for engine performance.

3.5 Miscellaneous Maintenance



CAUTION! Do not remove the plug wire to check for electrical spark. Damage to the ignition circuit may result.

Inspect the spark plugs every 100 hours of operation. Remove any deposits and adjust gap if necessary. See engine manual for further information.

Clean and inspect the spark arresters every 50 hours of operation. **Replace if damaged.**

Review the manufacturer's manual for maintenance intervals.

SECTION 4 REPLACEMENT PARTS

4.1 Engine Assembly

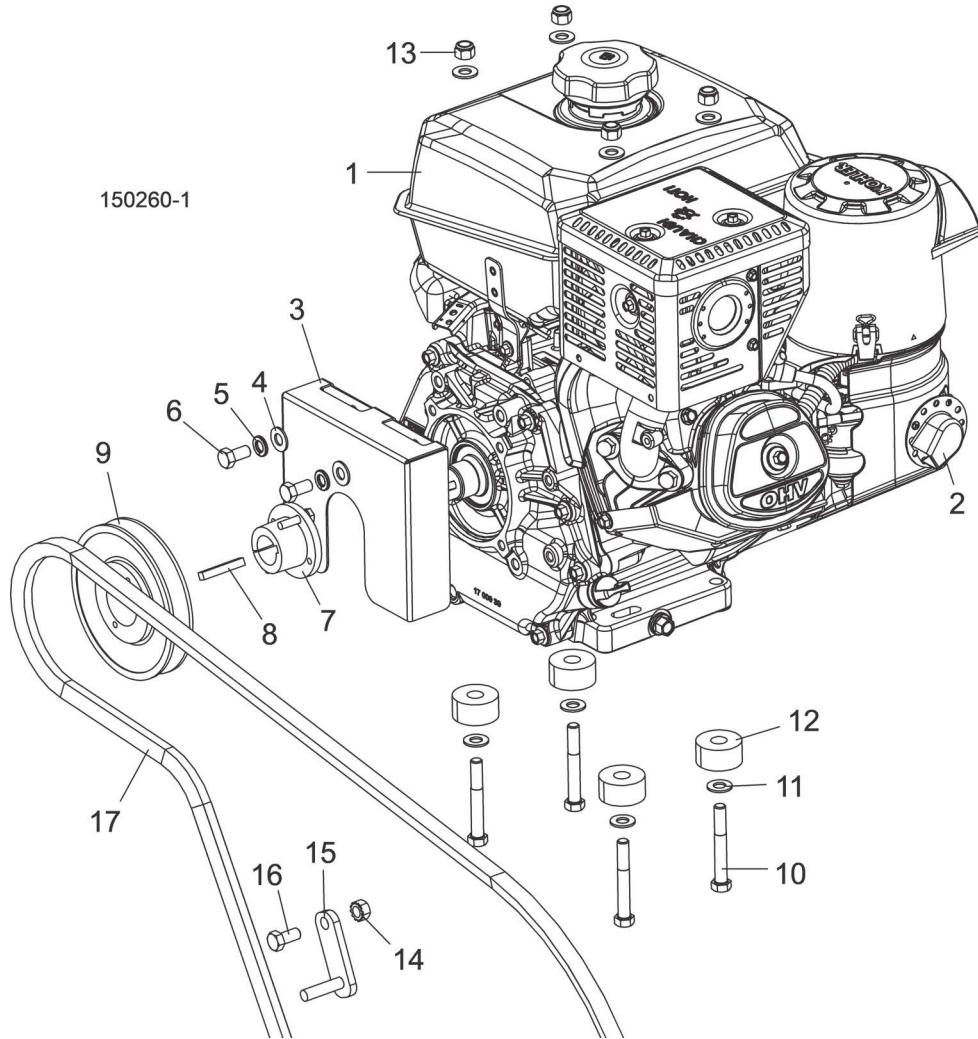

REF	PART #	DESCRIPTION	COMMENTS	QTY.
	P12393	COVER, ENGINE		1
	110052	ENGINE ASSEMBLY, LT15G14 START		1
1	X200-1201	Engine, 14HP Kohler		1
2	110187	Deflector, Kohler 14HP Exhaust		1
3	110188	Plate, LT15 Start Drive Guard		1
4	F05011-3	Washer, 3/8 Flat SAE		2
5	F05011-4	Washer, 3/8 Split Lock150260-1		2
6	F05007-27	Bolt, 3/8-16x3/4 HH Gr2		2
7	016513	Bushing, QT x 1"		1
8	S04124	Key, 1/4" X 1 11/16"		1
9	016512	Sheave, BK55QT		1
	061330	Kit, Air/Precleaner Filter 17 883 03-S1		1
	061331	Filter, Fuel Tank Fill 17 050 20-S		1

REF	PART #	DESCRIPTION	COMMENTS	QTY.
	061332	Filter, Engine Fuel 25 050 21-S1		1
	061333	Plug, Spark 25 132 19-S		1
10	F05007-206	BOLT, 3/8-16X2 3/4 HH GR5		4
11	F05011-3	WASHER, 3/8 FLAT SAE		8
12	034641	SPACER, 17/32X1 1/2X3/4		4
13	F05010-10	NUT, 3/8-16 HEX NYLOC		4
14	F05010-19	NUT, 3/8-16 KEPS		1
15	048237	SUPPORT WELDMENT, LT15G25 BELT		1
16	F05007-118	BOLT, 3/8-16X3/4 HH GR5		1
17	017943	BELT, BX87 DRIVE		1

4.2 Clutch Assembly

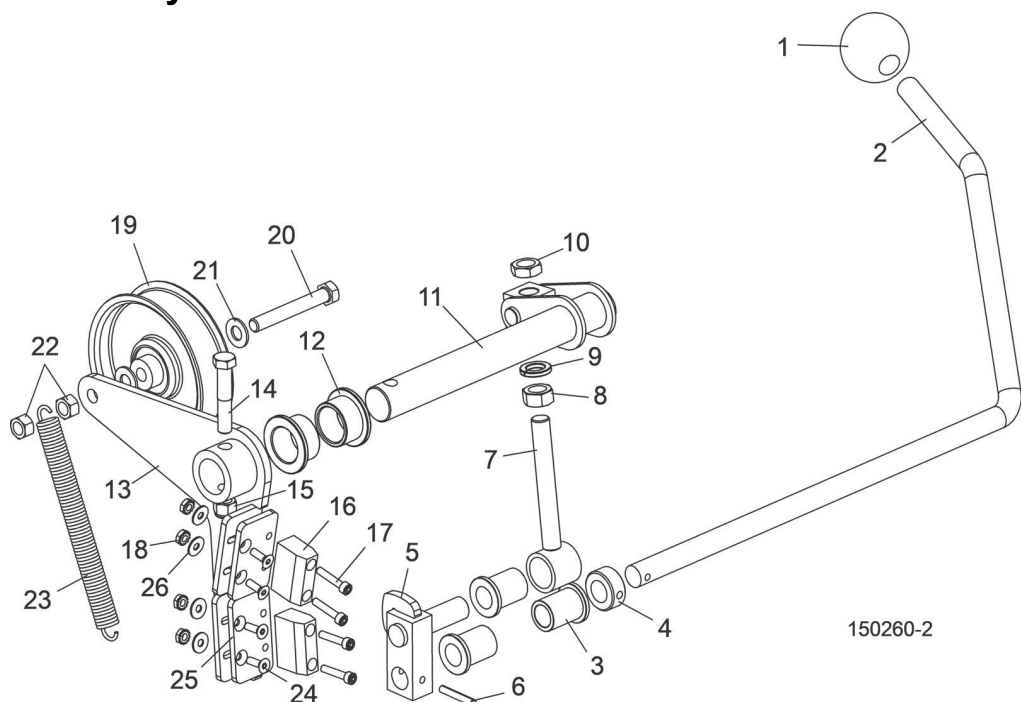

REF	PART #	DESCRIPTION	COMMENTS	QTY.
1	P04211	KNOB, 5/8-11 BALL		1
2	016487	HANDLE, LT15 CLUTCH		1
3	016486	BUSHING, 5/8 ID X 7/8 OD X 1 1/8 LONG FL BRONZE		3
4	P05035	COLLAR, 5/8 ID LOCK		1
5	065572	BLOCK WELDMENT, LINKAGE CLUTCH/BRAKE		1
6	F05012-16	PIN, 3/16 X 1 1/4 ROLL		1
7	034605	LINKAGE ASSEMBLY, W/BEARING		1
8	F05010-35	NUT, 1/2-13 FREE HEX, ZINC		1
9	F05011-9	WASHER, 1/2 SPLIT LOCK		1
10	F05010-31	NUT, 1/2-13 JAM		1
11	034608	PIVOT WELDMENT, CLUTCH/BRAKE		1
12	P737	BUSHING, 1 X 1 1/4 X 3/4 FLANGE BRONZE		2
	065874	BRAKE/CLUTCH ASSEMBLY, LT15		1
13	065873	Arm Weldment, Clutch/Brake LT15		1
14	F05007-124	Bolt, 3/8-16 x 2 Hex Head Gr5		1
15	F05010-10	Nut, 3/8-16 Hex Nylon Lock		1
16	016488	Block, LT15 Brake		2
17	F05004-2	Screw, 10-24 x 1 Socket Head		4
18	F05010-14	Nut, #10-24 Keps		8
19	034602	Idler, 4" O.D. x 3/8 Bore		1
20	F05007-230	Bolt, 3/8-16 x 2-3/4" Hex Head Gr5 Full Thread		1
21	F05011-3	Washer, 3/8 Flat		2
22	F05010-25	Nut, 3/8-16 Swaged Lock		2
23	034810	Spring, Idler Arm LT15/D/E/G		1
24	F05004-282	Screw, 10-24 x 5/8" FSHC		4

REF	PART #	DESCRIPTION	COMMENTS	QTY.
25	065872	Plate, Brake Adjustment		2
26	F05011-18	Washer, #10 SAE Flat		4