

D46 Engine

Safety, Operation, Maintenance & Parts Manual

LT70HD Super

rev. A5.04 - A5.08



Safety is our #1 concern! Read and understand all safety information and instructions before operating, setting up or maintaining this machine.

August 2017

Form #2284

California

Proposition 65 Warning



WARNING: Breathing gas/diesel engine exhaust exposes you to chemicals known to the State of California to cause cancer and birth defects or other reproductive harm.

Always start and operate the engine in a well-ventilated area.
If in an enclosed area, vent the exhaust to the outside.
Do not modify or tamper with the exhaust system.
Do not idle the engine except as necessary.

For more information go to www.P65warnings.ca.gov.



WARNING: Drilling, sawing, sanding or machining wood products can expose you to wood dust, a substance known to the State of California to cause cancer. Avoid inhaling wood dust or use a dust mask or other safeguards for personal protection.

For more information go to www.P65Warnings.ca.gov/wood.

©2019

Printed in the United States of America, all rights reserved. No part of this manual may be reproduced in any form by any photographic, electronic, mechanical or other means or used in any information storage and retrieval system without written permission from

Wood-Mizer
8180 West 10th Street
Indianapolis, Indiana 46214

Table of Contents

Section-Page

SECTION 1	ABOUT THIS MANUAL	1-1
SECTION 2	OPERATION	2-1
2.1	Starting The Engine.....	2-1
SECTION 3	MAINTENANCE	3-1
3.1	Safety	3-1
3.2	Engine Oil & Filter.....	3-3
3.3	Cooling System	3-4
3.4	Battery	3-5
3.5	Alternator Belt.....	3-6
3.6	Air Cleaner	3-7
3.7	Preliminary DPF Information.....	3-8
SECTION 4	REPLACEMENT PARTS	4-1
4.1	Fuel Tank Assembly (D46)	4-1
4.2	Engine Mount Assembly (LT70 Super Tier 4 Only).....	4-2
4.3	Engine Assembly (D46)	4-3
4.4	Drive Assembly (LT70 Super Only)	4-5
4.5	ECU Assembly (LT70 Super Tier 4 Only).....	4-6
4.6	Radiator Assembly (D46).....	4-8
4.7	Engine Pulley Guards (LT70 Super Tier 4 Only)	4-10
4.8	Bearing Support (LT70 Super Tier 4 Only)	4-11
4.9	Drive Belt Guard Assembly	4-12
	INDEX	I

SECTION 1 ABOUT THIS MANUAL

This manual is provided as a supplement to the equipment manufacturer's manuals. This manual provides information specific to the use of this equipment on the Wood-Mizer® sawmill. Refer to the sawmill operator's manual and manufacturer's manual before attempting to operate this equipment.



IMPORTANT! Read the sawmill operator's manual and engine manufacturer's manual for instructions and safety precautions before operating this equipment.

The information and instructions given in this manual do not amend or extend the limited warranties for the equipment given at the time of purchase.

SECTION 2 OPERATION

2.1 Starting The Engine

Engine Control Indicators

See **Figure 2-1**. The following indicators are located on the sawmill control panel display.



Battery Indicator: Shows the current battery voltage.



Engine Oil Pressure Indicator: Icon turns red when there is no oil pressure.



Engine Water Temperature Indicator: Shows the current engine temperature. Icon turns yellow when temperature is between 215F-225F (102C-107C). Icon turns red when temperature is above 225F (107C).



Cold Start Device Indicator: Shows when the air heater is running.



Engine RPM Indicator: Shows the current engine RPM.

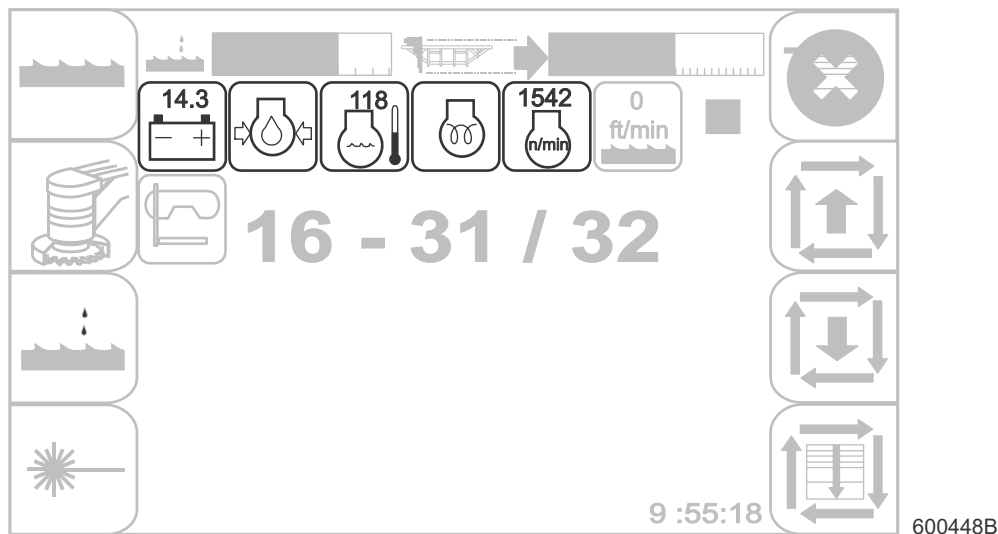

FIG. 2-1 LT70 SUPER SAWMILL ONLY

Engine Start



DANGER! Always be sure the blade is disengaged and all persons are out of the path of the blade before starting the engine. Failure to do so will result in serious injury.

DANGER! Operate your engine/machine only in well ventilated areas. The exhaust gases of your engine can cause nausea, delirium and potentially death unless adequate ventilation is present.

DANGER! Never operate an engine with a fuel or oil leak. The leaking fuel or oil could potentially come in contact with hot surfaces and ignite into flames.



WARNING! Be sure the joystick is in the neutral position before turning the key switch to the on (#1) or accessory (#3) position. This prevents accidental carriage movement which may cause serious injury or death.

WARNING! Do not operate engine without proper and operational spark arrester/muffler. Sparks emitted from the engine exhaust could ignite surrounding materials, causing serious injury or death.



CAUTION! Do not crank starter for more than 15 seconds at one time during starting attempts. Allow the starter motor to cool for 2 minutes before cranking the starter again. Damage to the engine may result.

CAUTION! Let engine idle for 3 - 5 minutes before applying load to prevent engine damage.

1. See the engine manufacturer's manual for lubricating oil recommendations for specific temperature ranges.
2. Use #2 or better quality diesel fuel for above freezing starting. Use a #1 quality diesel fuel for below freezing starting.
3. Turn the key switch on the control panel to the on (#1) position.
4. Wait for the air heater to finish heating up as indicated on the screen.
5. Be sure all persons are clear of the blade and turn the key switch to the start (#2) position and release.

Turn the key switch to the start (#2) position and release.

Engine Shutoff



CAUTION! A minimum 2 minute idle time is recommended to allow the battery charge to recover and to give the engine turbocharger time to spin down before the engine is shut off.

Turn the key switch to the off (#0) position.

SECTION 3 MAINTENANCE

Refer to the manufacturer's manual for maintenance intervals and procedures unless otherwise instructed in this manual. Follow the manufacturer's recommendations for dusty conditions.



IMPORTANT! This manual only provides information about additional procedures or procedures to be performed at different time intervals than found in the manufacturer's manuals. Refer to the manufacturer's manual for complete maintenance instructions.



WARNING! Clean sawdust from all guards, vents, control boxes, or any area where sawdust may gather **after every shift**. Failure to do so may result in fire, causing death or serious injury.



3.1 Safety

Use caution when performing maintenance or service to the engine.



DANGER! Always be aware of and take proper protective measures against rotating shafts, pulleys, fans, etc. Always stay a safe distance from rotating members and make sure that loose clothing or long hair does not engage rotating members resulting in possible injury.

DANGER! Engine components can become very hot during operation. Avoid contact with any part of a hot engine. The exhaust components of your engine are especially hot during and following operation. Contact with hot engine components can cause serious burns. Therefore, never touch or perform service functions on a hot engine. Allow the engine to cool sufficiently before beginning any service function.



WARNING! Remove the blade before performing any engine service. Failure to do so may result in serious injury.

WARNING! Always wear proper and necessary safety equipment when performing service functions. Proper safety equipment includes eye protection, breathing protection, hand protection and foot protection.



This symbol identifies the interval (hours of operation) at which each maintenance procedure should be performed. "AR" signifies maintenance procedures which should be performed as required.

3.2 Engine Oil & Filter



Check the oil level every 8 hours of operation. Add oil as necessary. See the engine manual for oil viscosity and grade recommendations.

When checking the oil level, inspect the oil for indications of water in the oil. If there is water present or the oil is cloudy, DO NOT start the engine. Replace the oil and oil filter, run the engine at low idle for no more than 2 minutes and replace the oil and filter again.



CAUTION! Operating the engine with water in the engine oil will cause severe damage to the engine. Follow all maintenance procedures for checking oil level and oil/filter change intervals.



IMPORTANT! The engine is equipped with a muffler rain cap to keep water out of the muffler and engine. If the sawmill is stored outside or transported during rainy weather, the muffler must be covered.



Change the engine oil and oil filter every 250 hours of operation.

3.3 Cooling System



Clean the radiator fins every 8 hours of operation. Spray the radiator with water from a hose or compressed air to clean sawdust from the radiator fins. Do not use a pressure sprayer.



CAUTION! Failure to keep the radiator fins clear of sawdust and/or dirt may cause the engine to overheat resulting in damage to the engine.

3.4 Battery

50

Check the battery electrolyte level every 50 hours of operation. See manufacturer's manual for instructions.



DANGER! Batteries expel explosive gases. Keep sparks, flames, burning cigarettes, or other ignition sources away at all times. Always wear safety goggles and a face shield when working near batteries. Failure to do so will cause serious injury.¹



WARNING! Battery posts, terminals and related accessories contain lead and lead compounds, chemicals known to the State of California to cause cancer and reproductive harm. Wash hands after handling.

1. Battery Council International, copyright 1987

3.5 Alternator Belt



The alternator belt is self-tensioning and should not need adjustment. If the battery continues to not charge properly or the belt continues to squeal after the initial belt adjustment, replace the belt.

1. Release the blade tension and remove the blade from the sawmill if necessary. Turn the key switch to OFF (0) and remove the key.
2. Remove the drive belt cover and alternator cover.
3. Pry the belt idler up and remove the belt from the alternator and engine pulleys.
4. While holding the idler up, install the new belt around the alternator and engine pulleys.
5. Release the idler on top of the belt and reinstall the alternator and drive belt covers.

3.6 Air Cleaner



Replace the air cleaner cartridge every 200 hours of operation. Change the cartridge more often if operating the sawmill in dirty conditions or if engine performance indicates a new cartridge is necessary.

3.7 Preliminary DPF Information

Preliminary DPF Information

(Information provided by the Yanmar Application Manual 0DTN4-EN0041 Rev.01 unless it is specific to the Wood-Mizer Control)

DPF System Explanation

Role of the DPF System

The diesel particulate filter (DPF) system is implemented in automobile diesel engines. It uses a soot filter (SF) to collect particulate matter (PM) from the exhaust has and safely processes it. Application of the DPF system complies with the Tier 4 emission standards set by the United States Environmental Protection Agency and the emission standards set by other countries.

Structure of All Devices

DPF

Structure of the DPF

The DPF consists of the diesel oxidation catalyst (DOC), the soot filter (SF), and the DPF case. The DPF cased includes the DOC and SF and leads the exhaust gas into them.

DOC	Ceramic carrier with catalyst coating.
SF	Ceramic. The exhaust gas is passed through the ceramic wall by alternately closing the channels. The PM is collected while passing through the wall.
DPF case	Stainless steel. The DOC is divided into the DOC case and the silencer room. (Some applications have an outlet flange only.) Each part is bolt-tightened to the body flanges. Do not use the DPF case after you dop it. The ceramic DOC and SF are fragile and can break.
Mat	Ceramic fiber. The mat holds the ceramic DOC and the SF in the metal case.

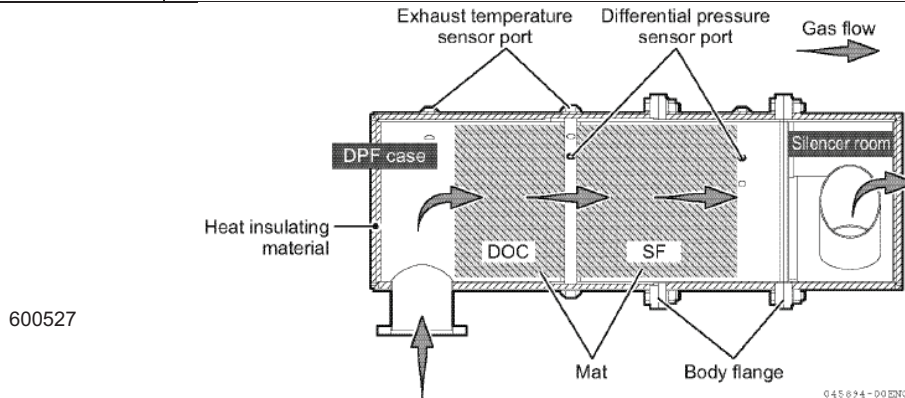

FIG. 3-1

Function of the DPF

The function of the DPF is to break down harmful substances in the DOC and to collect particulate matter in the SF, thus preventing the release of contaminants into the atmosphere. Particulate matter that accumulates in the SF of the DPF causes it to clog, reducing engine performance. Therefore it is necessary to burn off the accumulated PM. There are 3 incineration methods: continuous regeneration, intermittent regeneration, and additive regeneration. YANMAR engines use a continuous regeneration method, which allows the collection and at the same time incineration of particulate matter inside the DPF while continuing engine operation.

DPF

DPF exhaust temperature sensor

The DPF exhaust temperature sensors are directly fastened to the sensor ports (one in the front and one on the back of the DOC) installed in the DPF periphery.

DPF differential pressure sensor

The DPF differential pressure sensor is installed through the stay in the DPF flange and connected with the steel pipe attached to the DPF and rubber tube.

Precautions for Use (Precautions for Users)

- Fuel: Use light oil with a sulfur content (mass) of 15ppm or less (ultra-low sulfur) for DPF engines. If you use other than the specified fuel, sulfur will rapidly deteriorate the catalyst performance inside the DOC. When the regeneration performance of the DPF is inhibited and more particulate matter accumulates, the drop of engine output and the frequent switches to regeneration mode increase fuel costs and worsen the engine condition.
- Lubricating oil: use a low-ash oil as lubricating oil. If you use a different lubricating oil than specified, a large amount of ash is vented through the exhaust, and the DPF will clog quickly. This will not only cause the engine output to decrease and fuel costs to increase, but will also make frequent maintenance of the SF necessary.
- Precautions when performing the stationary regeneration.
 - Ventilate well.
 - If avoidable, do not perform the stationary regeneration in a closed place such as a storage shed.
 - Regeneration causes the temperature around the tail pipe to increase.
 - Make sure there are no flammable materials or people nearby.
- If your engine is equipped with DPF cleaning alarm, clean the DPF when the alarm lamp comes on. If your engine is not equipped with DPF cleaning alarm, clean the DPF every 6000 hrs of operation.
- As the DPF is subject to emission regulations, disassembly by the user is prohibited. If a repair is required, consult a specialized service shop.
- Refer to the service manual for maintenance methods and intervals regarding ash removal.
- The smell of the exhaust gas from the DPF is different from that of a conventional engine. This is not a defect.
- White smoke may come out of the tail pipe during starting. This is water vapor and not problematic.
- If the operation requires waiting time with low-idle rather than actual traveling, DPF regeneration at normal operation may be difficult to operate. Therefore the stationary regeneration may need to be done more often.

FIG. 3-2

Diesel Particulate Filter (DPF) System Control Overview

Overview

YANMAR's DPF system continuously burns particulate matter that accumulates on the SF (soot filter). This is called DPF regeneration.

Electrical equipment such as the DPF differential pressure sensor, temperature sensor and intake air throttle are installed to the DPF. If the DPF can not continue to regenerate while operating at low load, the E-ECU automatically assist the DPF regeneration (DPF regeneration assistance) using the electrical equipment and avoiding accumulation of particulate matter.

The table below shows the outline of DPF regeneration assistance. YANMAR uses an original DPF regeneration method that combines regeneration by the regeneration assistance devices (intake air amount control by the intake air throttle and extension of the injection timing by the common rail) and regeneration by the common rail multi-step injection (post-injection by the common rail).



Terminology	Control content	Explanation	Remarks
Self regeneration	Regeneration without regeneration assist unit (normal)	In a high speed and high load operation, the exhaust temperature rises and PM are burnt and removed continuously.	There regenerations can be performed during operation. No operator intervention is needed.
Assisted regeneration	Regeneration with regeneration assist unit.	In a low speed and low load operation, the exhaust temperature is too low for continuous regeneration.	
Reset regeneration	Regeneration with assist regeneration and post injection.	Therefore the E-ECU automatically performs the regeneration controls shown on the left to increase the exhaust temperature and burn/remove PM.	
Stationary regeneration	Regeneration with more effective reset regeneration and automatic control to engine speed suitable for DPF regeneration <div style="text-align: center;">  DPF Regen Req lamp </div> <div style="text-align: center;">  Trouble Lamp </div>	In a low speed/low load operation continuing long time, the assist regeneration/reset regeneration may not be enabled because the exhaust temperature does not rise sufficiently. If the PM deposit amount reaches a certain level in this situation, the DPF Regen Req lamp and Trouble lamp illuminate. At that time, the operator can start the stationary regeneration to burn/remove PM by operating the DPF regeneration request switch.	When DPF Regen Req lamp illuminates, the operator should move the machine to a safe place without any flammable matters nearby before operating the stationary regeneration. Do not perform any working operation because a special control dedicated to DPF regeneration takes place.

FIG. 3-3

DPF regeneration and operator interface

Description

The table below indicates the specifications of each DPF regeneration and operator interface.







	Name	Specification
Input	Regeneration interlock switch	<p>Because the engine ECU changes the target speed automatically in stationary regeneration, it is necessary to inform the engine ECU that the interlock is enabled.</p> <p>Once you are on the DPF regeneration screen, high throttle is disabled. You must then engage the Auto-clutch with the joystick before the Interlock switch can be turned on. Once the Interlock switch is turned on the throttle will idle down to 800 RPM in order to permit stationary regeneration.</p>
	 Interlock off	
	 Interlock on	
	DPF regeneration request switch	
	 Unpressed	
	 Pressed	
	DPF regeneration inhibit switch	<ul style="list-style-type: none"> • Used for inhibiting manual reset regeneration. • Used for interrupting reset/stationary regeneration. <p>It is recommended to have regeneration inhibited so that the operator can choose when to run reset/stationary regeneration. You do not want reset/stationary regeneration to run when you are in an enclosed space or around flammable materials. The exhaust system will get extremely hot during reset/stationary regeneration.</p>
	 Uninhibited	
	 Inhibited	

FIG. 3-4







	Name	Specification		
Output	Failure lamp	Used for notifying operators of the following status.		
	 Off	Flash	When stationary regeneration standby in the emergency condition, during the backup mode, and the ash cleaning is required.	
	 On		When there is an active DTC from any ECU on the sawmill.	
	DPF Regen inhibit lamp	Used for notifying operators that reset/stationary regeneration is in "inhibited" state.		
	 Off	On	While DPF regeneration inhibit switch is in "Regeneration inhibited" state	
	 On			
DPF Regen Req lamp	Used for notifying operators of reset/stationary regeneration standby status to prompt operators to start regeneration and also notifying operators that stationary regeneration is in process.			
 Off	On	<ul style="list-style-type: none"> • While DPF regeneration inhibit switch is in "Regeneration inhibited" state, when stationary regeneration is permitted (50h have passed since the last reset or last stationary regeneration.) • During stationary regeneration standby or in back up mode 		
 On				
		Flash	<ul style="list-style-type: none"> • During reset regeneration standby (during reset regeneration, DPF regeneration inhibit switch is in "Regeneration inhibited" state) 	

FIG. 3-5

3

Maintenance

Preliminary DPF Information





	Name	Specification
Output	DPF Regen Ack lamp	Used for notifying operators of reset/stationary regeneration standby status to prompt operators to start regeneration and also notifying operators that stationary regeneration is in process.
	 Off	<ul style="list-style-type: none"> • Stationary regeneration is in process • For 3 seconds after DPF regeneration request switch is pressed and held
	 On	
		Flash
EGT lamp	Used for notifying operators of high exhaust temperature caused by reset/stationary regeneration.	
	 Off	Reset/stationary regeneration is active.
	 On	

FIG. 3-6

Operation

[1] Self regeneration (normal operation) and assist regeneration operating

- When the DPF regeneration inhibit switch is set to “Regeneration permitted” state.



- Regeneration Req lamp explanation.

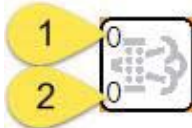

- (1) DPF regeneration mode status
 - 0 = Normal operation
 - 1 = Assist regeneration
 - 2 = Reset regeneration
 - 3 = Stationary regeneration
- (2) DPF regeneration control status
 - 0 = Normal operation or notification of DPF regeneration control
 - 1 = Start of automatic speed control by ECU (gradually acceleration)
 - 2 = +After injection and retard, intake throttle operation (target position limitation)
 - 3 = +Intake throttle operation (no limitation of target position)
 - 4 = +Post injection (phase 1)
 - 5 = +Judgement of finishing the DPF regeneration (start of judgement by the DPF middle temperature)
 - 6 = +Post injection (phase 2)
 - 7 = +Judgement of finishing the DPF regeneration
 - 8 = +Finish of automatic speed control by ECU (gradually deceleration)
 - 9 = +Accumulation value reset
- When the DPF regeneration inhibit switch is set to “Regeneration inhibited” state.

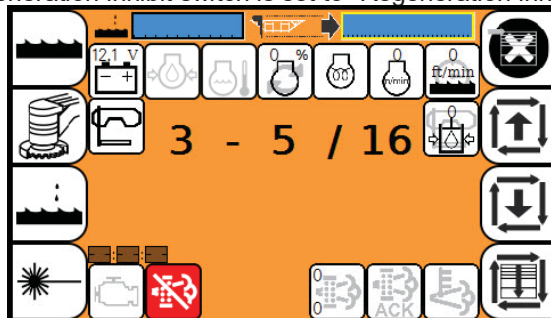

FIG. 3-7

3

Maintenance

Preliminary DPF Information

- To set the DPF regeneration inhibit switch to “Regeneration inhibited”, go to the “User

Configuration” screen by pressing the “Function Key”  on the HMI.

- On the “User Configuration” screen, turn the “Encoder”  on the HMI, to highlight “DPF Regeneration”, then press the “Encoder” to go to the “DPF Regeneration” screen.

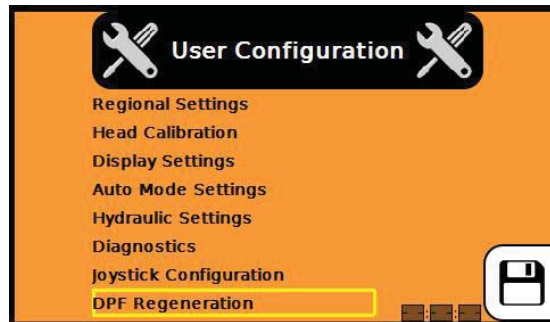

- On the “DPF Regeneration” screen, press the bottom left “Soft Key”, shown below, to set the regeneration inhibit switch to “Regeneration inhibited”.

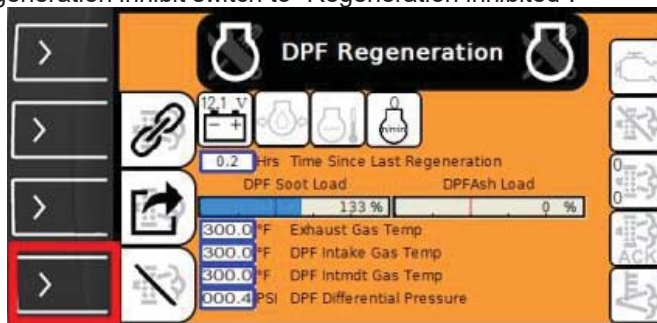

- When the regeneration inhibit switch is set to “Regeneration inhibited”, the “DPF Regeneration” screen will look like the image below.



When 50 hours have passed since the last reset/stationary regeneration, DPF transfers to the state [2] or [3] described below.

FIG. 3-8

**[2] Self regeneration (normal operation) and assist regeneration operating
 (Elapsed time since last reset: 50 hours or more, regeneration inhibited state)**

- When 50 hours have passed with the DPF regeneration inhibit switch set to “Regeneration inhibited” state since the last reset/stationary regeneration, the DPF Regen Req lamp illuminates. This means that stationary regeneration execution is permitted. According to the need for stationary regeneration, set the DPF regeneration inhibit switch to “Regeneration permitted” state and perform operation [3] described below.



- When 100 hours have passed since the last reset, DPF transfers to the reset regeneration standby state [5] described later.

**[3] Self regeneration (normal operation) and assist regeneration operating
 (Elapsed time since last reset: 50 hours or more, no regeneration inhibition)**

- When 50 hours have passed since the last reset, stationary regeneration execution is permitted.



- At that time, setting the interlock switch to “Regeneration permitted” state and holding the DPF regeneration SW to “ON” state for 3 seconds or more causes the DPF to transfer to the stationary regeneration standby state [6] described later. For the operation method after stationary regeneration standby state, refer to [6] described later.

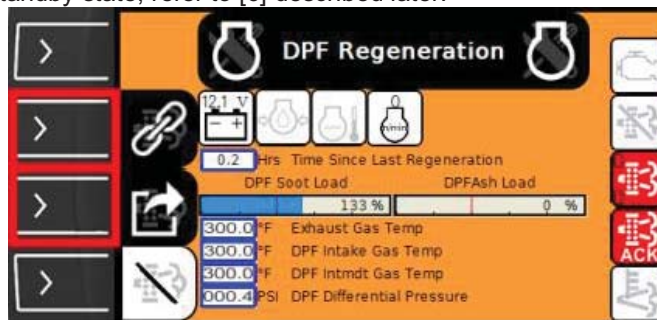

FIG. 3-9

3 Maintenance

Preliminary DPF Information

- When 100 hours have passed since the last reset, reset regeneration is started automatically, transfer to [4] described below.

[4] Reset regeneration operating (Elapsed time since last reset: 100hours, no regeneration inhibition)

- The reset regeneration is completed in approximately 25 to 30 minutes.



- After the reset regeneration completion, DPF transfers to [1] described above.
- When the DPF regeneration inhibit switch is set to “Regeneration inhibited” state, the reset regeneration stops and DPF transfers to the reset regeneration standby state [5] described later.

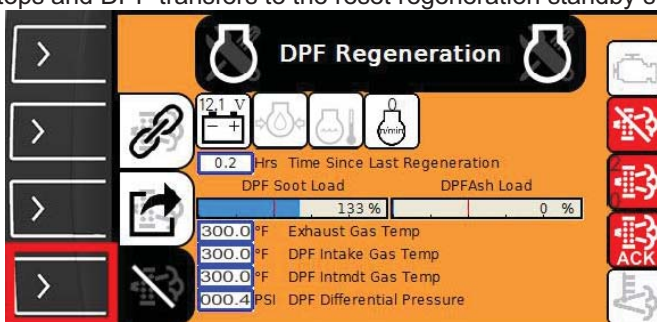

- Regeneration request lamp blinks
- Regeneration acknowledge lamp blinks
- As in [3] described above, setting the interlock switch to “Regeneration permitted” state and holding the DPF regeneration request switch to “ON” state for 3 seconds of more causes the DPF to transfer to the stationary regeneration standby state [6] described later.

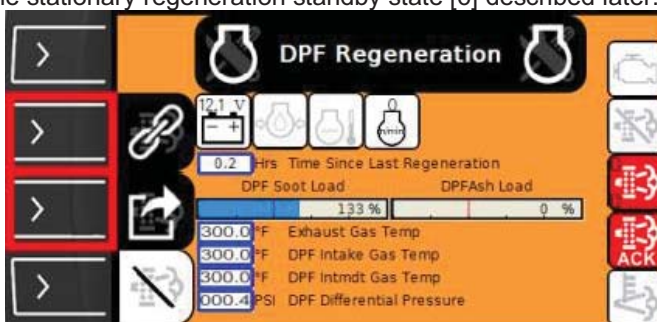
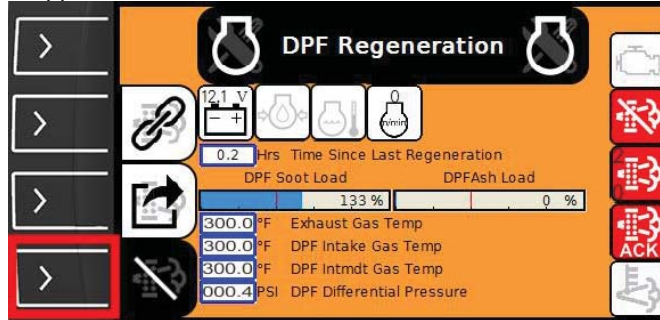

FIG. 3-10

[5] Reset regeneration standby (Elapsed time since last reset: 100hours, regeneration inhibited state)

- While the DPF regeneration inhibit switch is set to “Regeneration inhibited” state, the reset regeneration is stopped.



- Regeneration request lamp blinks
- Regeneration acknowledge lamp blinks
- When 1 hour has passed in the reset regeneration standby state, DPF automatically transfers to the stationary regeneration standby state [6] described below. For details on the stationary regeneration standby, refer to [6] described below.
- If the PM deposit amount decreases by a certain amount in the reset regeneration standby state, the reset regeneration ends automatically and transfers to the normal operation [1] described above.

[6] Stationary regeneration standby

- An operator intervention ([3], [4] above) (hereinafter referred to as “Allow state”) or detection of certain PM deposit amount or more (hereinafter referred to as “Emergency state”) causes the DPF to transfer to the stationary regeneration standby.
- When the transition is made from the above “Allow” condition to the stationary regeneration standby, only the regeneration request lamp is turned on.



FIG. 3-11

3

Maintenance

Preliminary DPF Information

- When the transition is made from the above “Emergency” condition, the DTC, SPN 3719 – DPF Operator Interface, FMI 16 – Stationary regeneration standby, is displayed.

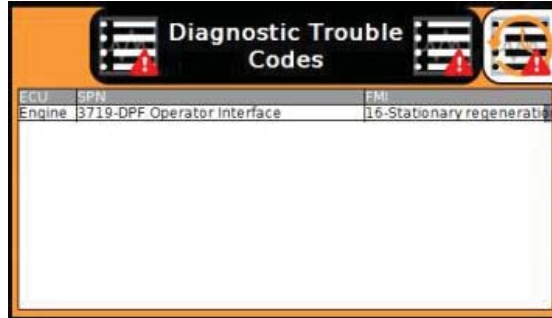

- Press the “Esc” key on the HMI to back to the screen that was active before the code appeared.
- Regeneration request lamp turns on and the failure lamp blinks.



- Make sure to refer to *Stationary regeneration execution on page ###* and confirm the operation procedures and precautions for the interlock switch and DPF regeneration request switch before starting stationary regeneration, transfer to [7] described later.
- If a certain length of time elapses AND the PM deposit amount reaches to or above a certain level, DPF automatically transfers to the backup mode [8] described later.

Stationary regeneration operating

- The stationary regeneration is completed in approximately 25-30 minutes. After the stationary regeneration completion, DPF transfers to [1] described above.



FIG. 3-12

- If the stationary regeneration has started in the Allow state, setting the DPF regeneration inhibit SW to “Regeneration inhibited” state interrupts the stationary regeneration and DPF transfers to the state [2] described above. On the other hand, when the interlock switch is set to “Nonrenewable” state while the DPF regeneration inhibit switch is set to “Regeneration permitted” state, the stationary regeneration is interrupted and the DPF transfers to the state [3] described above.
- If the stationary regeneration has started in Emergency state, any of the following operations interrupts the stationary regeneration and DPF transfers to stationary standby state [6] described above.
 - Set DPF regeneration inhibit switch to “Regeneration inhibited” state
 - When the interlock switch is turned to the “Regeneration prohibition” condition
 - Command an accelerator position equal to or more than the minimum position
 - Turn key switch to OFF

[8] Backup mode

- In backup mode, the engine is operated with speed limit and/or max. injection amount limit.



- In backup mode, DTC for the relevant factor as listed below is displayed along with the specified DTC, SPN 3719 – DPF Operator Interface, FMI 0 – Back up mode.
 - If the PM deposit amount (C method) is equal to or larger than a certain amount, DTC, SPN 522573 – DPF, FMI 0 – Over accumulation (C method)
 - If the PM deposit amount (P method) is equal to or larger than a certain amount, DTC, SPN 522574 – DPF, FMI 0 – Over accumulation (P method)
 - If the PM deposit amount is equal to or larger than a certain amount even after stationary regeneration has been executed for a specified time, DTC, SPN 522575 – DPF, FMI 7 – Regeneration defect (stationary regeneration failed)
 - If a certain length of time elapses in stationary regeneration standby state, DTC, SPN 522577 – DPF, FMI 11 – Regeneration defect (stationary regeneration not operated)
- To cancel the backup mode, you need to use the service tool (SA-D).

Stationary regeneration execution

Even when the engine ECU performs assist regeneration or reset regeneration, PM may not be burnt (DPF may not be regenerated) if idling with no load or operation with low speed/load is repeated frequently. At that time, if the engine ECU judges that stationary regeneration should be executed, it illuminates the DPF Regen Req lamp and Trouble lamp. When the DPF Regen Req lamp illuminates, the engine ECU needs to control the engine speed automatically to perform a process of burning PM, stationary regeneration. Continued operation with the DPF Regen Req lamp illuminated allows PM to accumulate excessively and may cause an abnormal burning of PM, resulting in DPF damage or fire. Therefore, perform stationary regeneration by operating the regeneration interlock switch and the DPF

FIG. 3-13

regeneration request switch according to the procedure below. When starting stationary regeneration in such a situation, you should basically activate the interlock function by operating the interlock switch. When performing stationary regeneration, follow the precautions listed below.

Safety precautions

- Do not do a stationary regeneration in a badly ventilated location. There is the danger of carbon monoxide poisoning.
- Make sure that there are no flammables near the exhaust pipes to avoid fires.
- Do not touch the exhaust pipes during stationary regeneration to avoid injury. Make sure that there are no people close to the exhaust pipes.
- After stationary regeneration starts, white smoke may be discharged from the exhaust pipe. This is not a fault but steam discharged when the exhaust temperature is low. As the exhaust temperature increases, the white smoke will disappear.
- Stationary regeneration may not operate while the engine is cold. Start it after the engine is warmed up.
- The exhaust gas has a different odor from that of a conventional diesel engine. This is not a fault. The different odor is generated because the exhaust gas is purified by the catalyst integrated in DPF.

Operating procedures for stationary regeneration

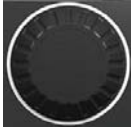
1. Move to a safe location that is well-ventilated.
2. Go to the “User Configuration” screen by pressing the “Function Key”  on the HMI.
3. On the “User Configuration” screen, turn the “Encoder”  on the HMI, to highlight “DPF Regeneration”, then press the “Encoder” to go to the “DPF Regeneration” screen.



4. Engage the Auto-clutch with the joystick. While on the “DPF Regeneration” screen, high throttle is disabled.

FIG. 3-14

5. If the Regeneration inhibit switch is set to “Regeneration inhibited” state:

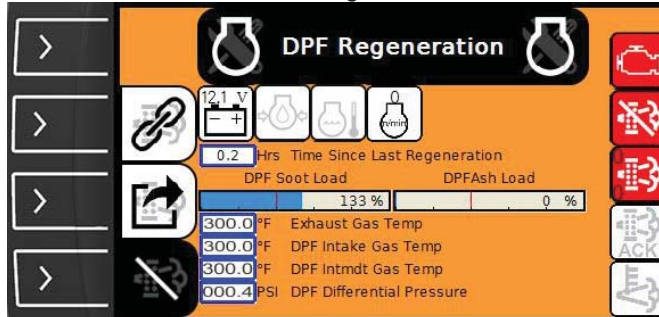

- a. Press the bottom left soft key to set it to the “Regeneration permitted” state.

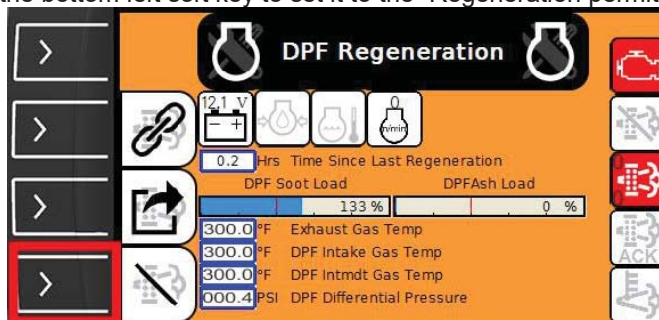

6. Engage the Auto-clutch to prevent the belt from slapping around during regeneration because the engine RPM will raise.
 a. You cannot set the interlock switch, shown below, until the auto-clutch is engaged.
7. Set the Interlock switch to the “Regeneration permitted” state, by pressing the 2nd left soft key.

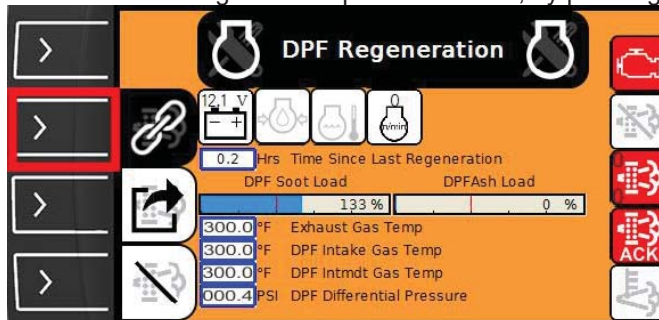

- a. The engine throttle will lower to 800RPM once the Interlock switch is set to the “Regeneration permitted” state.
 b. The Regen Ack lamp flashes.
8. Press and hold the 3rd left soft key for the Regen request switch, for 3 seconds, stationary regeneration starts.
 a. When stationary regeneration starts, the engine speed will gradually increase to high idle speed and reset regeneration will be performed under this operation condition.

FIG. 3-15

3 Maintenance

Preliminary DPF Information

- b. When stationary regeneration starts, the DPF Req lamp turns off, Trouble lamp turns off, the DPF Regen Ack lamp changes from flashing to constant illumination, and the EGT lamp illuminates.

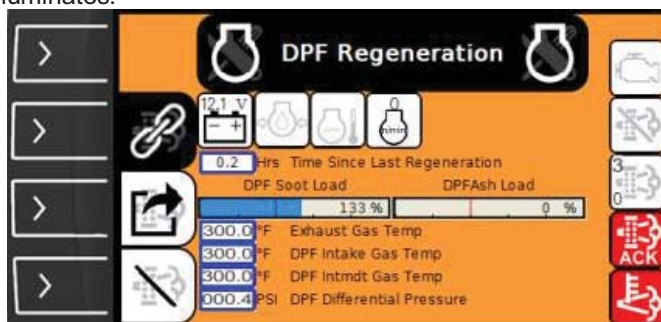

- c. The stationary regeneration will be finished after approximately 25-30 minutes.
- d. To abort the stationary regeneration, perform either of the following operations.
 - i. Set the interlock switch to “Nonrenewable” state.
 - ii. Set the DPF regeneration switch to “Regeneration inhibited” state.
 - iii. Turn the key switch to OFF.
- f. When the above time has passed, the engine speed gradually decreases to the low idle speed and the DPF Regen Ack lamp and EGT lamp turn off. Stationary regeneration is completed.

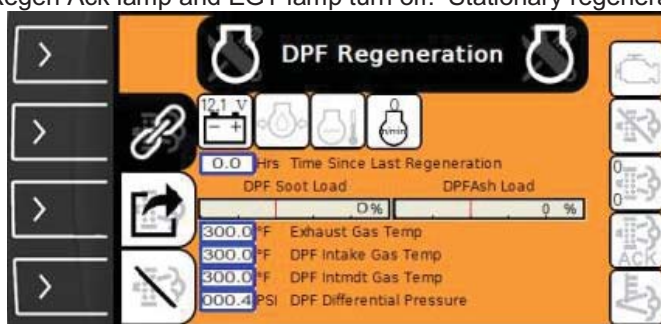

- g. Press the 2nd left soft key to turn off the Interlock switch.

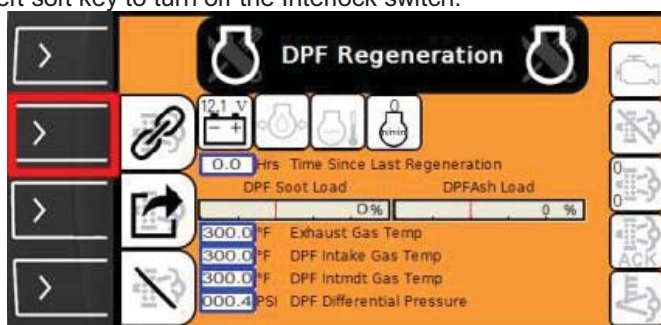

- a. The engine idle will return to the normal low idle of 1550RPM and the Auto-clutch will disengage.

FIG. 3-16

D46

SECTION 4 REPLACEMENT PARTS

4.1 Fuel Tank Assembly (D46)

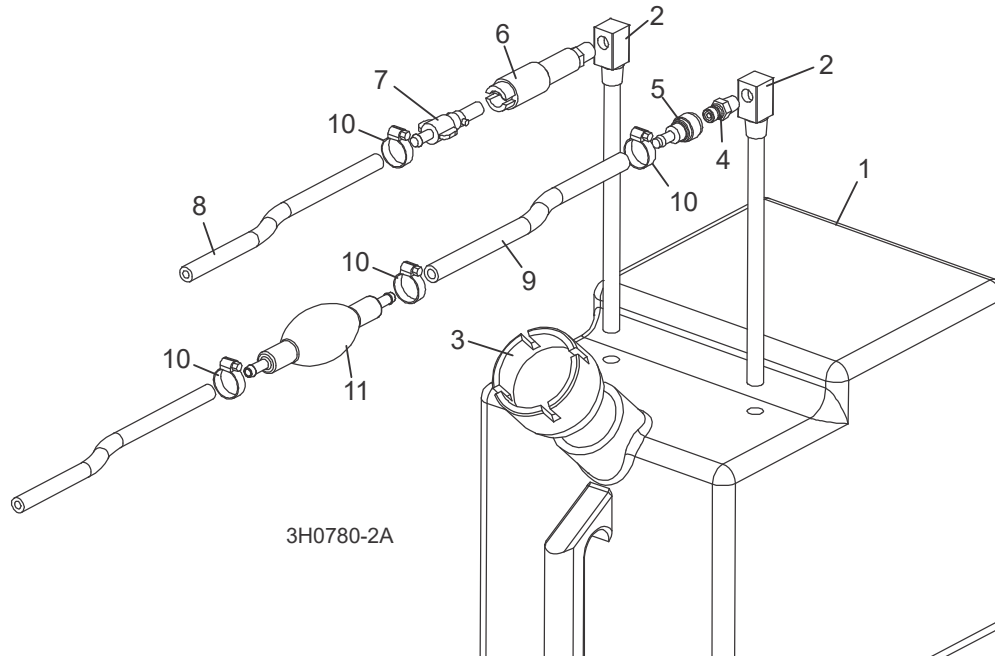

REF	DESCRIPTION (◆ Indicates Parts Available In Assemblies Only)	PART #	QTY.	
	TANK ASSEMBLY, 5 GALLON DIESEL	A12132	1	
1	Tank, 5 Gallon Fuel	P12166	1	◆
2	Pickup, 9" Fuel	P12172	2	
3	Cap 2X3 Fuel	P09683	1	
4	Fitting, 1/4" NPT Male Quick Disconnect	015583	1	
5	Fitting, Female Quick Disconnect Barb	015582	1	
6	Fitting, 1/4NPT Male-Female Discon	P12175	1	
7	Fitting, 1/4" Barb Plastic Male Disconnect	P12176	1	
8	HOSE, 1/4" ID FUEL	P642	5.83 Ft	
9	HOSE, FUEL 5/16" EPA 15G CARB	R02423-3 ¹	8 Ft.	
	HOSE, 5/16" ID FUEL	016338	1 Ft.	
10	CLAMP, 11/16" HOSE	P12739 ²	2	
11	BULB, 5/16" FUEL LINE PRIMER	006687 ²	1	
	ADDITIVE, DIESEL FUEL 16OZ BOTTLE	004878 ³	1	
	BULB KIT, DIESEL PRIMER	061080	1	

¹ R02423-3 replaced 016338 with increased length of 12" after 1/22/2021 per ECN 37785.

² Bulb 006687 and (2) P649 deleted after 1/22/202, per ECN 37785.

³ Stanadyne Performance Formula helps eliminate contaminants and water in fuel, prevents gelling in cold weather, and improves lubrication of fuel system parts. 16 oz. bottle treats 60 gallons of diesel fuel.

D46

4 Replacement Parts Engine Mount Assembly (LT70 Super Tier 4 Only)

4.2 Engine Mount Assembly (LT70 Super Tier 4 Only)

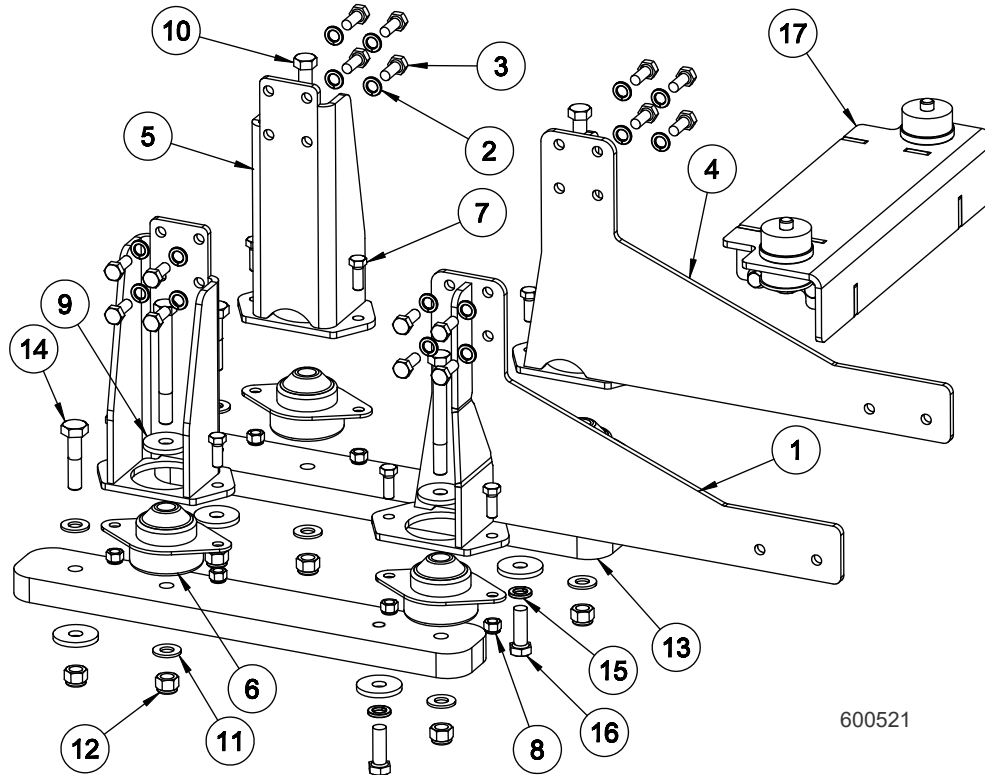

600521

REF	DESCRIPTION (◆ Indicates Parts Available In Assemblies Only)	PART #	QTY.
	MOUNT ASSEMBLY, LT70 D46 T4 MOTOR	079254	1
1	Weldment, Yanmar Left Engine Mount	006521	1
2	Washer, 10MM Split Lock	F05011-88	16
3	Bolt, M10-1.5x25 Hex Head Cl 8.8	F81003-11	16
4	Weldment, Yanmar Right Engine Mount	006522	1
5	Weldment, LT70 D46 T4 Rear Engine Mount	079265	2
6	Mount, Vibration Isolator	036095	4
7	Bolt, 3/8-16x1 Gr5 Hex Head	F05007-87	8
8	Nut, 3/8-16 Hex Nyl Lock	F05010-10	8
9	Washer, .52x1.69	014632	8
10	Bolt, 1/2-13x4 1/2 GR5 Hex Head	F05008-35	4
11	Washer, 1/2 SAE Flat	F05011-2	6
12	Nut, 1/2-13 Nyl Hex Lock	F05010-8	6
13	Plate, D46 T4 Engine Mount Riser	079263	2
14	Bolt, 1/2-13x2 1/4 Hex Head GR5	F05008-10	2
15	Washer, 1/2 Split Lock	F05011-9	2
16	Bolt, 1/2-13x1 1/2 Hex Head Gr5	F05008-33	2
17	Assembly, Yanmar Lower Radiator Mount (See Section 4.6 for parts)	074229	1

D46

4.3 Engine Assembly (D46)

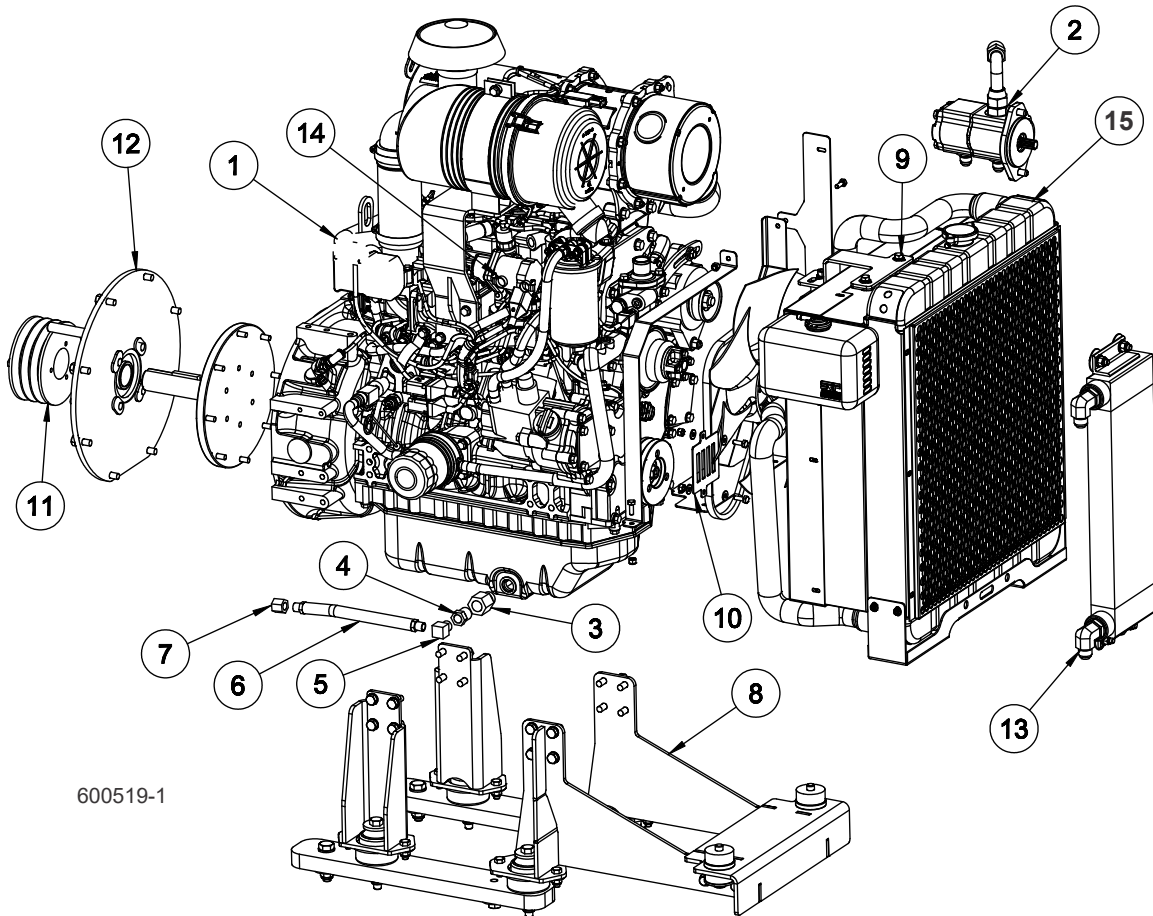

600519-1

REF	DESCRIPTION (◆ Indicates Parts Available In Assemblies Only)	PART #	QTY.
	COVER, ENGINE	CED47	1
	ASSEMBLY, SUPER 70 D46 T4 FINAL YANMAR ENG	079149	1
1	Engine, Yanmar 46HP Tier4 Final Diesel	079148	1
2	Assembly, D46 T4 Dual Hydraulic Oil Pump (<i>See Sawmill Parts Manual</i>)	079253	1
	Assembly, Yanmar 55HP Oil Drain	074263	1
3	Fitting, M22-1/2 NPT	006640	1
4	Fitting, 1/2 NPT x 3/8 NPT Hex Reducer	028073	1
5	Fitting, 3/8NPT Street Elbow 90	046026	1
6	Hose, 3/8NPTx9 5/8 Rubber	P10082	1
7	Cap, 3/8 Pipe Galvanize	P04332	1
8	Assembly, LT70 D46 T4 Motor Mount (<i>See Section 4.2</i> for parts)	079254	1
9	Assembly, Yanmar Upper Radiator Mount (<i>See Section 4.6</i> for parts)	074227	1
10	Assembly, KR9 Radiator Cutout Cover (<i>See Section 4.6</i> for parts)	074231	1
11	Assembly, LT70 Hyd 55HP Stub Shaft (<i>See Section 4.4</i> for parts)	074514	1

D46

4

Replacement Parts Engine Assembly (D46)

12	Assembly, D46 T4 Final Bearing Support (See Section 4.8 for parts)	079262	1	
13	Assembly, Hydraulic Oil Cooler (See Sawmill Parts Manual)	074531	1	
14	Hose Clamp, 7/32in-5/8in	P649	2	
	Hose, Fuel 5/16" EPA 15G CARB (ft.)	R02423-3	16	
	Connector, 1Pos Deutsch Recpt 8-10Ga	078126	1	
	Contact, 8-10AWG Deutsch Sz 8 Male	078128	1	
15	Radiator, Diesel Engines #KR9 (See Section 4.6 for parts)	006517	1	
	Cap, Rain D46 Tier 4 KDPF-2	061305	1	
	Front Main Seal, Yanmar TNV88 119934-01800	057932	1	
	Seal, Rear Engine 129795-01780	061311	1	
	Sensor, Yanmar Crank Speed 129A00-21710	078713	1	
	Glow Plug, Starter Aid, Yanmar TNV88 129008-77800	057945	1	
	Oil Filter, Yanmar TNV 129150-35170	057935	1	
	Assembly, Water Pump 129A01-42000	061313	1	
	Sensor, Temp Yan Installed/Bolt On Wire 129927-44900	061172	1	
	Seal, Yanmar Oil Drain 22190-220002	057944	1	
	Thermostat, Yanmar TNV 129155-49801	057938	1	
	Gasket, Thermostat Cover 129795-49551	044652	1	
	Gasket, Thermostat 129150-49811	061312	1	
	Sensor, Yanmar Fuel Temperature 129A00-51200	078715	1	
	Pump, Yanmar Supply 129A00-51000	078717	1	
	Injector, Yanmar 129A00-53100	078716	1	
	Filter, Fuel 129A00-55800	061308	1	
	Filter, Water Separator 129A00-55730	061310	1	
	Pump, Yanmar Fuel Feed 129612-52100	078705	1	
	Starter, Yanmar D47.5 129136-77011	061748	1	
	Assembly, Alternator 129052-77220	061314	1	
	Switch, Oil Pressure Tier 3 LT70 Super 119761-39450	061245	1	
	Assembly, Water Separator 129A00-59700	061309	1	
	Assembly, Air Filter D46 Tier 4 KAC18	061322	1	
	Filter, Air D46 Tier 4 129687-12510	061323	1	

D46

4.4 Drive Assembly (LT70 Super Only)

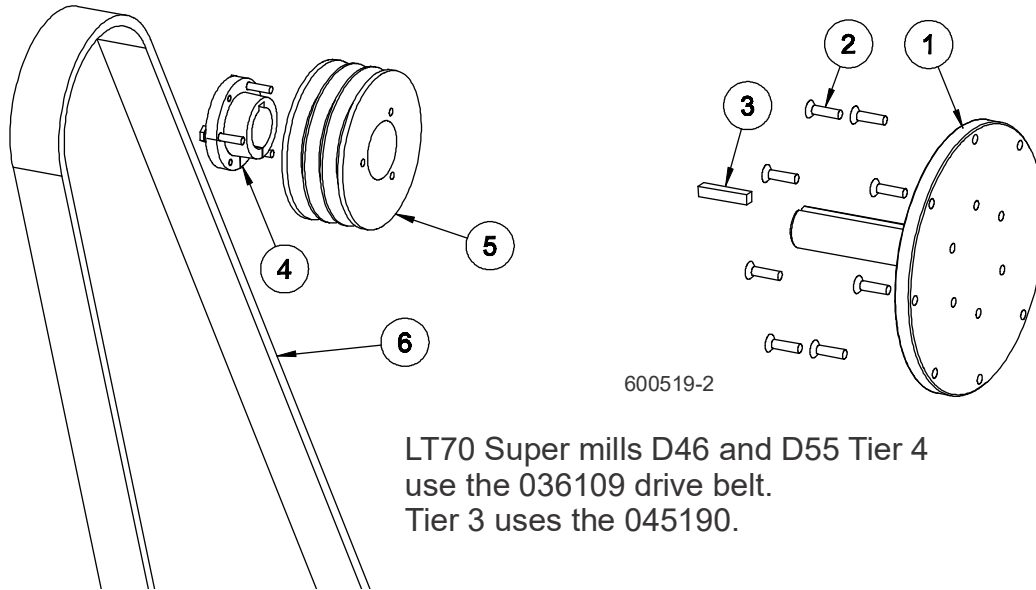

LT70 Super mills D46 and D55 Tier 4
use the 036109 drive belt.
Tier 3 uses the 045190.

REF	DESCRIPTION (◆ Indicates Parts Available In Assemblies Only)	PART #	QTY.
	SHAFT ASSEMBLY, LT70 HYDRAULIC YANMAR STUB	074514	1
1	Shaft, Yanmar Large Drive Stub	071326	1
2	Bolt, M8-1.25 X 30mm Flat Socket Head	F05004-245	8
3	Key, 3/8" x 3/8" x 1 7/8"	014693	1
4	Bushing, 1 7/16" SDS	038174	1
5	Sheave, 3/5V5.5 SDS	006320	1
6	Belt, 3/5VXFL975 Drive (common to various models)	036109	1

D46

4 Replacement Parts ECU Assembly (LT70 Super Tier 4 Only)

4.5 ECU Assembly (LT70 Super Tier 4 Only)

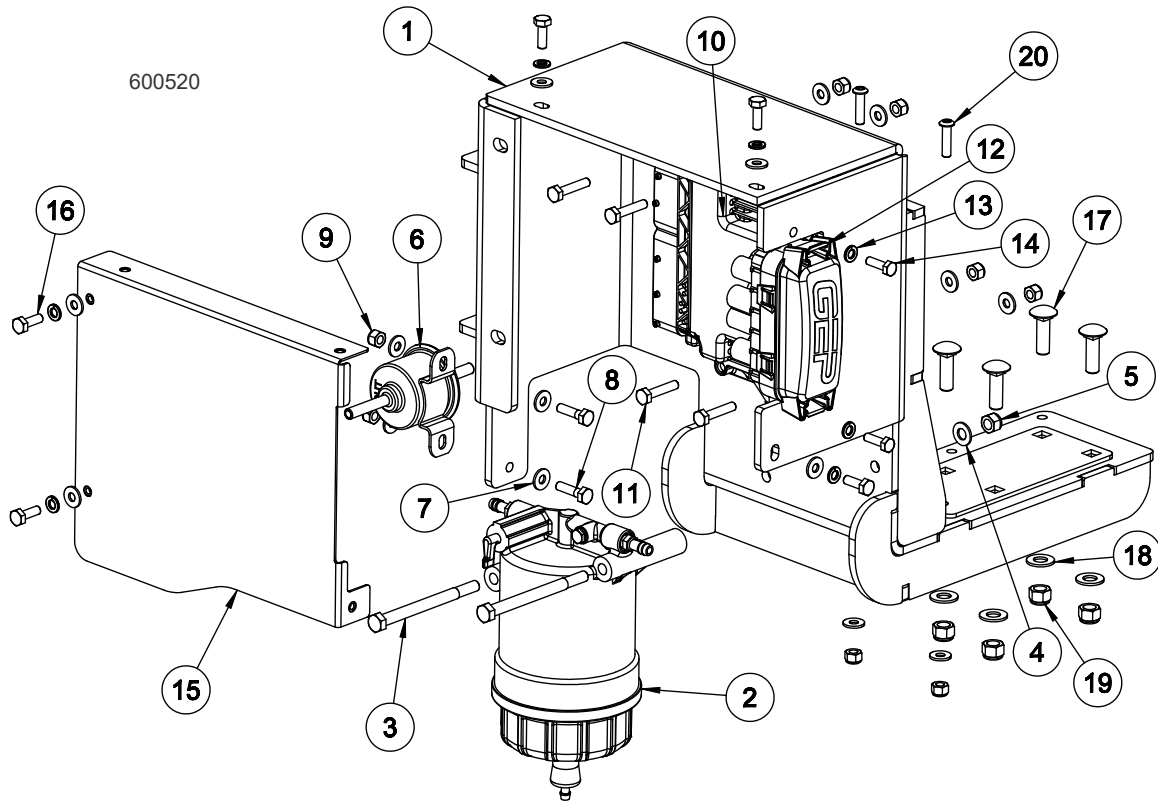

REF	DESCRIPTION (◆ Indicates Parts Available In Assemblies Only)	PART #	QTY.
	ECU ASSEMBLY, LT70D46 T4	079334	1
1	Weldment, LT70D46 T4 ECU Mnt	079463	1
2	Assembly, Water Separator 129A00-55700	061309	1
	Filter, Water Separator 129A00-55730	061310	1
3	Bolt, 5/16-18x4 Hex Head Gr5	F05006-109	2
4	Washer, 5/16 SAE Flat	F05011-17	2
5	Nut, 5/16-18 Nyl Lock	F05010-58	2
6	Pump, Yanmar Fuel Feed	078705	1
7	Washer, 1/4 SAE Flat	F05011-11	15
8	BOLT, 1/4-20 X 1 HEX HEAD GR5	F05005-101	2
9	Nut, 1/4-20 Nylock	F05010-69	8
10	Yanmar T4 Final ECU (Supplied w/Engine)	N/A ¹	1
11	Bolt, 1/4-20x1 1/4 Hex Head Gr5	F05005-116	4
12	Assembly, D46 T4 Fuse/Relay (Supplied w/Engine)	N/A	1
	Relay, Start/Glow Plug 30M9206	061315	2
	Fuse, Max 60 299060	061316	1
	Fuse, Max 80 299080	061317	1

D46

Replacement Parts

ECU Assembly (LT70 Super Tier 4 Only)

4

13	Washer, 1/4 Split Lock	F05011-14	7	
14	Bolt, M6-1x20 Hex Head Class 8	F05020-6	2	
15	Weldment, LT70D46 T4 ECU Cover	079455	1	
16	Bolt, 1/4-20x3/4 Hex Head Gr5	F05005-123	5	
17	Bolt, 3/8-16x1 1/4 Carriage Gr5	F05007-127	4	
18	Washer, 3/8 Flat SAE	F05011-3	4	
19	Nut, 3/8-16 Hex Nyl Lock	F05010-10	4	
20	Bolt, 1/4-20x1 SBHC BO	F05005-200	2	

¹ When replacing the ECU, it is necessary to update the software of the ECU using the designated service tool. Please contact Yanmar for details.

D46

4 Replacement Parts Radiator Assembly (D46)

4.6 Radiator Assembly (D46)

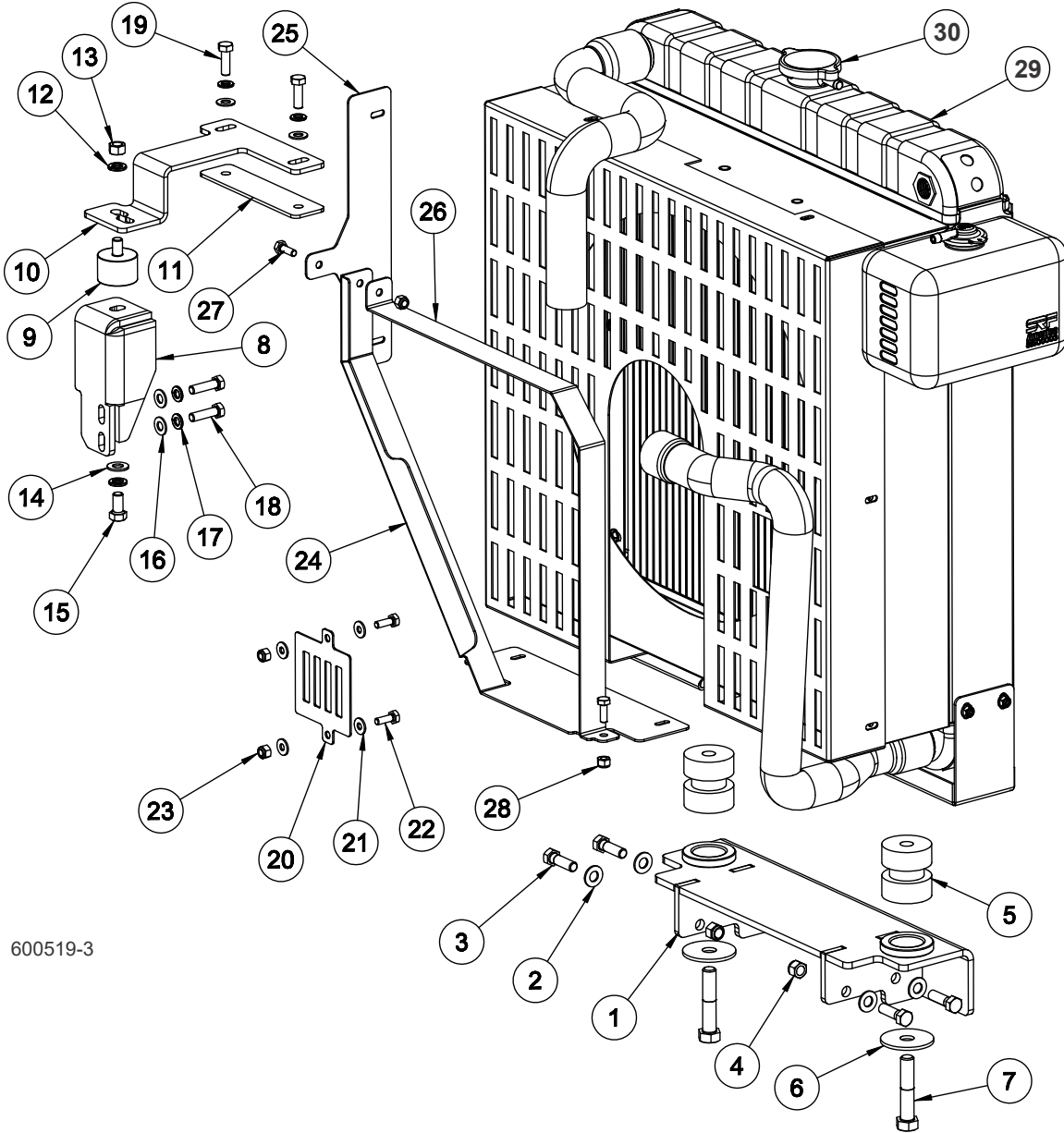

600519-3

REF	DESCRIPTION (◆ INDICATES PARTS AVAILABLE IN ASSEMBLIES ONLY)	PART #	QTY.
	ASSEMBLY, YANMAR LOWER RADIATOR MOUNT	074229	1
1	Weldment, Yanmar Radiator Mount	006530	1
2	Washer, 3/8 Flat SAE	F05011-3	4
3	Bolt, 3/8-16x 1 1/4 Hex Head Gr5	F05007-123	4
4	Nut, 3/8-16 Hex Nyl Lock	F05010-10	4
5	Bushing, Rubber Mount	018734	2

D46

Replacement Parts Radiator Assembly (D46)

4

6	Washer, Motor Mount	018751	2	
7	Bolt, Hex Head 1/2-13x2 3/4 Gr5 Zinc	F05008-144 ¹	2	
	ASSEMBLY, YANMAR UPPER RADIATOR MOUNT	074227	1	
8	Plate, Yanmar Top Radiator Mount	006558	1	
9	Bushing, Rubber Radiator Mount	028217	1	
10	Plate, Yanmar Formed Top Support	006713	1	
11	Plate, Top Radiator Mount Spacer	006557	1	
12	Washer, 3/8 Split Lock	F05011-4	2	
13	Nut, 3/8-16 Hex	F05010-1	1	
14	Washer, 3/8 Flat SAE	F05011-3	1	
15	Bolt, 3/8-16x3/4 Hex Head Gr2	F05007-27	1	
16	Washer, 5/16 SAE Flat	F05011-17	4	
17	Washer, 8mm Split Lock, Zn	F05011-45	4	
18	Bolt, M8-1.25x30mm Hex HeadC FT	F05021-11	2	
19	Bolt, M8x1.25x25 Hex Head FT	F05004-40	2	
	ASSEMBLY, KR9 RADIATOR CUTOUT COVER	074231	1	
20	Plate, KR9 Radiator Cutout Cover	006769	1	
21	Washer, 1/4 SAE Flat	F05011-11	4	
22	Bolt, 1/4-20x3/4 FT Hex HeadC	F05005-1	2	
23	Nut, 1/4-20 Nylock	F05010-69	2	
24	PLATE, D46 T4 RADIATOR LOWER COVER	079275	1	
25	PLATE, KR9 RADIATOR SIDE GUARD	006732	1	
26	PLATE, KR9 RADIATOR GUARD WRAP	006731	1	
27	BOLT, 1/4-20X3/4 FT HEX HEADC	F05005-1	2	
28	NUT, 1/4-20 NYLOCK	F05010-69	2	
29	RADIATOR, DIESEL ENGINES #KR9	006517	1	
30	Cap, Yanmar Radiator #129987-44570	044660	1	
	COOLANT OVERFLOW, YANMAR #129689-44000	061087	1	

¹ F05008-144 replaced F05008-74 per ECN 38392 on 2/22/22.

D46

4 Replacement Parts Engine Pulley Guards (LT70 Super Tier 4 Only)

4.7 Engine Pulley Guards (LT70 Super Tier 4 Only)

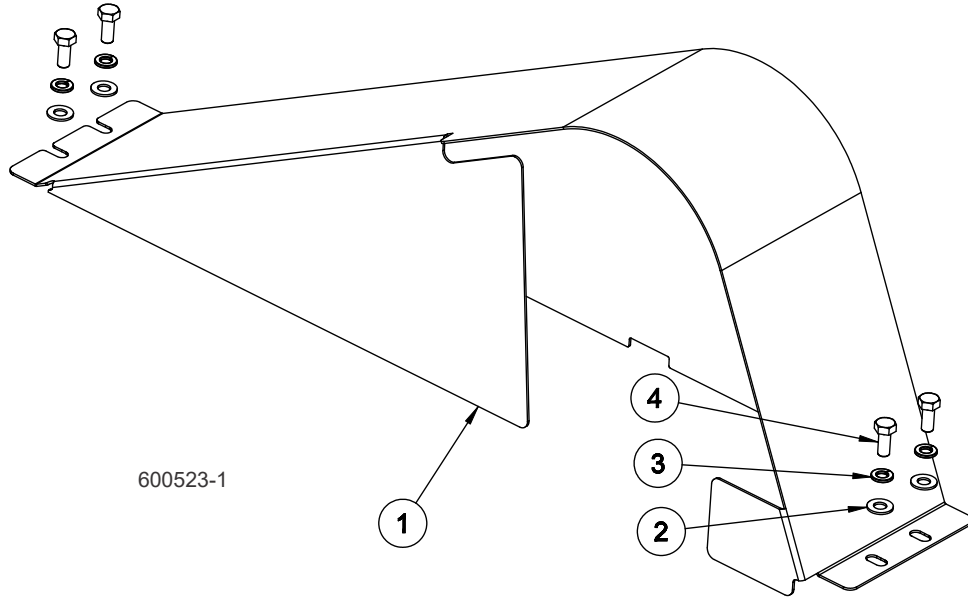

REF	DESCRIPTION (◆ Indicates Parts Available In Assemblies Only)	PART #	QTY.
1	COVER WELDMENT, LT70D46 T4 TOP PULLEY	079342	1
2	WASHER, 5/16 SAE FLAT	F05011-17	4
3	WASHER, 5/16 SPLIT LOCK	F05011-13	4
4	BOLT, 5/16-18X3/4 HHC	F05006-5	4

D46

4.8 Bearing Support (LT70 Super Tier 4 Only)

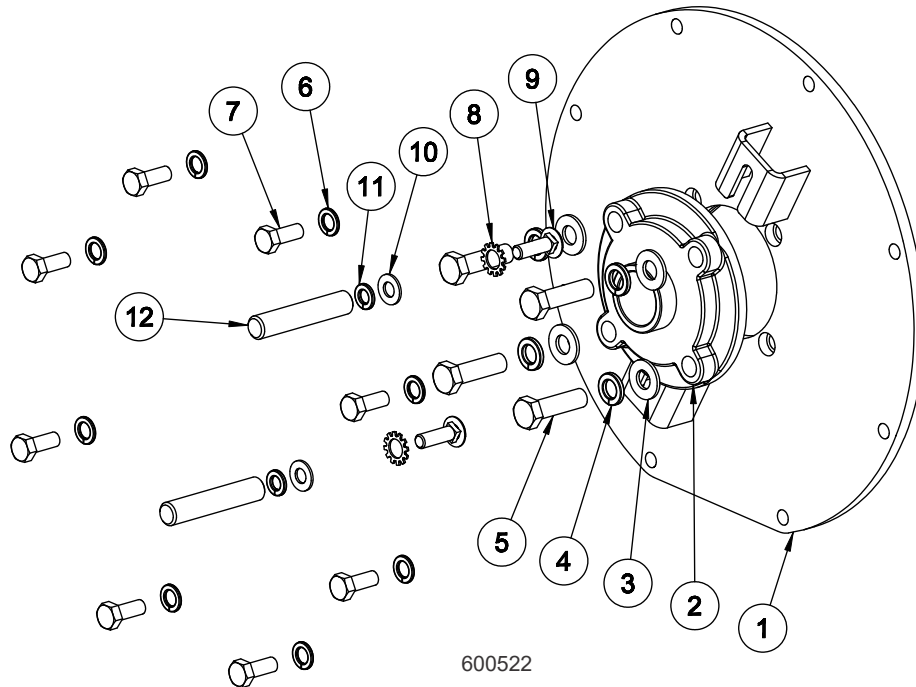

REF	DESCRIPTION (◆ Indicates Parts Available In Assemblies Only)	PART #	QTY.
	ASSEMBLY, D46 T4 FINAL BEARING SUPPORT	079262	1
1	Weldment, D46 T4 Final Bearing Support	079261	1
2	Bearing, 1-7/16 4-Bolt Flange	071491	1
3	Washer, 1/2 SAE Flat	F05011-2	4
4	Washer, 1/2 Split Lock	F05011-9	4
5	Bolt, 1/2-13x1 3/4 Hex HeadGR5 FT Zinc	F05008-88	4
6	Washer, 10MM Split Lock	F05011-88	8
7	Bolt, M10-1.5x25 Hex Head Cl 8.8	F81003-11	8
8	Washer, 1/2 Star ET	F05011-39	2
9	Bolt, 3/8-16x1 1/4 Carriage Gr5	F05007-127	2
10	Washer, 3/8 Flat SAE	F05011-3	2
11	Washer, 3/8 Split Lock	F05011-4	2
12	Rod, LT70 Clutch Enhancement	074751	2

D46

4 Replacement Parts Drive Belt Guard Assembly

4.9 Drive Belt Guard Assembly

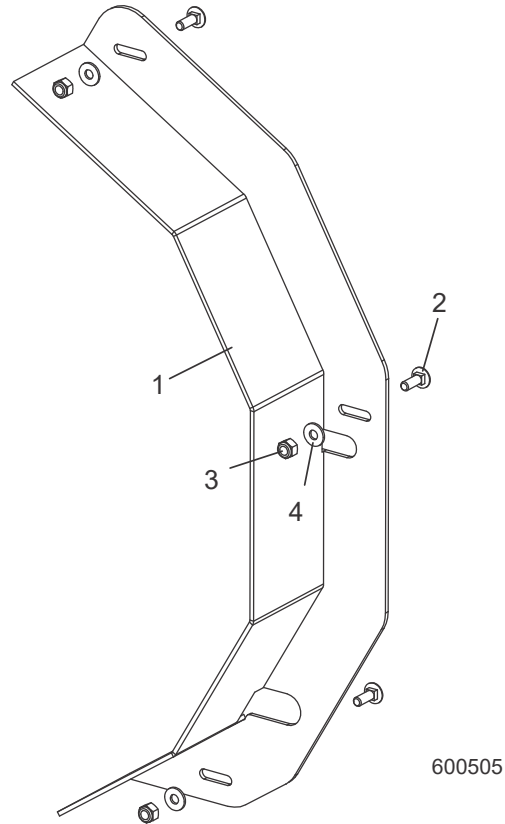

REF	DESCRIPTION (◆ Indicates Parts Available In Assemblies Only)	PART #	QTY.	
	GUARD ASSEMBLY, LT70 DRIVE BELT	079141	1	
1	Guard Weldment, LT70 Drive Belt Guard	079132	1	
2	Bolt, 1/4-20x3/4 Carriage	F05005-113	3	
3	Nut, 1/4-20 Nylock	F05010-69	3	
4	Washer, 1/4 SAE Flat	F05011-11	3	

INDEX

M

maintenance 3-1
air cleaner 3-7, 3-8
air filter 3-7, 3-8
alternator belt 3-6
battery 3-5
cooling system 3-4
engine oil 3-3

P

parts list
drive assembly 4-5, 4-6
engine assembly 4-3
engine mount assembly 4-2
fuel tank assembly 4-1
motor assembly 4-3
pulley guards 4-10
radiator assembly 4-8

R

replacement parts 4-1

S

starting 2-1