

LT35 G25 Engine

Safety, Operation, Maintenance & Parts Manual

074399 Engine, LT35 G25

rev. B

Safety is our #1 concern!

November 2022

Form #1726

**Used with
LT35
LT35HD**

**rev. A1.00 - A6.17
rev. A1.00 - A6.19**



WARNING! Read and understand this manual before using this machine.

California
Proposition 65 Warning



WARNING: Breathing gas/diesel engine exhaust exposes you to chemicals known to the State of California to cause cancer and birth defects or other reproductive harm.

Always start and operate the engine in a well-ventilated area.
If in an enclosed area, vent the exhaust to the outside.
Do not modify or tamper with the exhaust system.
Do not idle the engine except as necessary.

For more information go to **www.P65warnings.ca.gov**.



WARNING: Drilling, sawing, sanding or machining wood products can expose you to wood dust, a substance known to the State of California to cause cancer. Avoid inhaling wood dust or use a dust mask or other safeguards for personal protection.

For more information go to **www.P65Warnings.ca.gov/wood**.

Active Patents assigned to Wood-Mizer, LLC

Wood-Mizer, LLC has received patents that protect our inventions which are a result of a dedication to research, innovation, development, and design. Learn more at: woodmizer.com/patents

©2024 Wood-Mizer LLC

Printed in the United States of America, all rights reserved. No part of this manual may be reproduced in any form by any photographic, electronic, mechanical or other means or used in any information storage and retrieval system without written permission from

Wood-Mizer, LLC
8180 West 10th Street
Indianapolis, Indiana 46214

SECTION 1 OPERATION

2.1 About This Manual 2-1
2.2 Starting The Engine 2-1

SECTION 2 MAINTENANCE

3.1 Safety 3-1
3.2 Cooling System 3-1
3.3 Air Filter & Pre-Cleaner 3-1
3.4 Fuel Filter 3-1
3.5 Battery 3-2
3.6 RPM Adjustments 3-2
3.7 Miscellaneous Maintenance 3-2

SECTION 3 REPLACEMENT PARTS

4.1 Fuel Tank 4-1
4.2 Engine Assembly 4-2
4.3 Alternator Assembly 4-4
4.4 Throttle/Clutch Assembly 4-5

SECTION 2 OPERATION

2.1 About This Manual

This manual is provided as a supplement to the equipment manufacturer's manuals. This manual provides information specific to the use of this equipment on the Wood-Mizer® sawmill. **Refer to the sawmill operator's manual and manufacturer's manual before attempting to operate this equipment.**



IMPORTANT! Read the sawmill operator's manual and engine manufacturer's manual for instructions and safety precautions before operating this equipment.

The information and instructions given in this manual do not amend or extend the limited warranties for the equipment given at the time of purchase.

2.2 Starting The Engine

ENGINE START



DANGER! Always be sure the blade is disengaged and all persons are out of the path of the blade before starting the engine. Failure to do so will result in serious injury.

Operate your engine/machine only in well ventilated areas. The exhaust gases of your engine can cause nausea, delirium and potentially death unless adequate ventilation is present.

Never operate an engine with a fuel or oil leak. The leaking fuel or oil could potentially come in contact with hot surfaces and ignite into flames.



WARNING! Do not operate engine without proper and operational spark arrester/muffler. Sparks emitted from the engine exhaust could ignite surrounding materials, causing serious injury or death.

1. Close the engine choke by pulling the choke cable knob out.
2. Turn the key switch to the START position and release. Release the key switch to the RUN position after the engine starts.
3. When the engine starts, slowly push the choke cable knob in.

ENGINE SHUTOFF

1. Disengage the clutch handle to stop the blade if necessary.
2. Let the engine run for 15 seconds with no load, then turn the key switch to the OFF position.

SECTION 3 MAINTENANCE

Refer to the manufacturer's manual for maintenance intervals and procedures unless otherwise instructed in this manual. Follow the manufacturer's recommendations for dusty conditions.



IMPORTANT! This manual only provides information about additional procedures or procedures to be performed at different time intervals than found in the manufacturer's manuals. Refer to the manufacturer's manual for complete maintenance instructions.



WARNING! Clean sawdust from all guards, vents, control boxes, or any area where sawdust may gather **after every shift**. Failure to do so may result in fire, causing death or serious injury.



3.1 Safety

Use caution when performing maintenance or service to the engine.



DANGER! Always be aware of and take proper protective measures against rotating shafts, pulleys, fans, etc. Always stay a safe distance from rotating members and make sure that loose clothing or long hair does not engage rotating members resulting in possible injury.

DANGER! Engine components can become very hot during operation. Avoid contact with any part of a hot engine. The exhaust components of your engine are especially hot during and following operation. Contact with hot engine components can cause serious burns. Therefore, never touch or perform service functions on a hot engine. Allow the engine to cool sufficiently before beginning any service function.



WARNING! Remove the blade before performing any engine service. Failure to do so may result in serious injury.

WARNING! Always wear proper and necessary safety equipment when performing service functions. Proper safety equipment includes eye protection, breathing protection, hand protection and foot protection.

3.2 Cooling System

Wash the engine or brush off sawdust and debris every 50 hours of operation.

Clean the grass screen, cooling fins, and external surfaces.

Remove any dust, dirt or oil.

See engine manual for further instructions.

3.3 Air Filter & Pre-Cleaner

Service the pre-cleaner **every four hours** of operation by gently shaking excess sawdust and debris from the foam piece.

Clean the air filter (air cleaner element) and pre-cleaner (element wrapper) **every eight hours** of operation.

Replace the air filter (cleaner) **every 200 hours** of operation.

Replace the pre-cleaner (element wrapper) **every 2000 hours** of operation.

See the engine manual for further instructions.

3.4 Fuel Filter

Replace the fuel filter every 100 hours of operation or as required for engine performance.

3.5 Battery

Check the battery electrolyte level every 50 hours of operation. See manufacturer’s manual for instructions.

 **DANGER!** Keep sparks, flames, burning cigarettes, or other ignition sources away at all times.

Always wear safety goggles and a face shield when working near batteries. Failure to do so will cause serious injury.

 **WARNING!** Battery posts, terminals and related accessories contain lead and lead compounds, chemicals known to the State of California to cause cancer and reproductive harm. Wash hands after handling.

3.6 RPM Adjustments

 **WARNING!** Remove the blade before performing any engine service. Failure to do so may result in serious injury.

Check the RPM with a tachometer every 200 hours of operation.

Engine	High End RPM	Low End RPM
G25	3600	1800

1. Check prior to adjusting:

- Belt and brake strap tensions are correct (See the Maintenance section of the Operator’s Manual).
- Check oil, fuel, and coolant levels
- Check that the cable spring, cable guide, cable, and throttle brackets are aligned

NOTICE It is important that the above components are aligned. Proper alignment allows any slack in the cable (when engine is idling) to slide down into the cable spring. This maintains free operation of the cable and prevents the cable from kinking. Make sure the shoulder bolt does not rub against the crankcase vent tube.

2. Start the engine to measure the low-end RPM.
3. Refer to the engine manual to adjust the low-end RPM.
4. Engage the clutch handle to throttle the engine and measure the high-end RPM.

The high-end RPM is factory-set at 3600. Readjust the throttle cable if necessary to increase or reduce the high-end engine speed.

The throttle cable should be tensioned just enough so that the engine revs as soon as the clutch/brake handle is engaged.

NOTE: A properly adjusted throttle will extend the cable spring 1/4” to 3/8” (6.4 - 9.5 mm) when running and have a slight amount of slack in the cable when idling.

3.7 Miscellaneous Maintenance

1. Clean and inspect the spark arresters every 50 hours of operation. Replace if damaged.

 **CAUTION!** Do not remove the plug wire to check for electrical spark. Damage to the ignition circuit will result.

2. Inspect the spark plugs every 100 hours of operation.
3. Remove any deposits and adjust gap if necessary.
4. Review the manufacturer's engine manual for maintenance intervals.
5. See engine manual for further information.

SECTION 4 REPLACEMENT PARTS

4.1 Fuel Tank

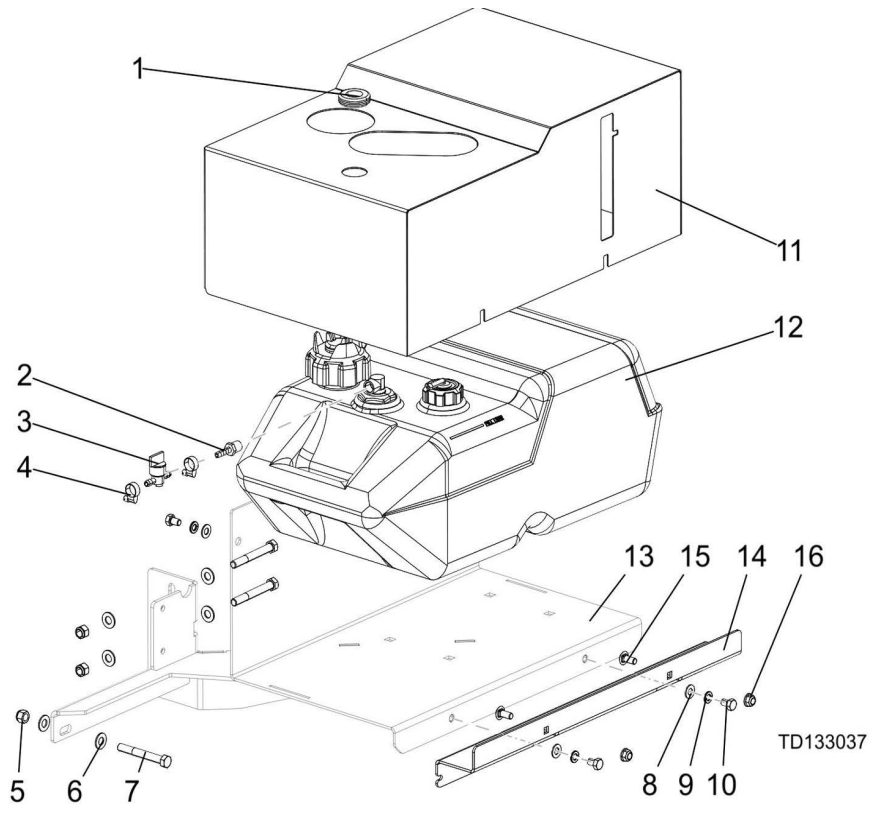

REF	PART #	DESCRIPTION	COMMENTS	QTY.
	133037	Assy, Fuel Tank Tray, LT28/35		1
1	p702	Grommet, 7/8In IDx1 1/4In Groove Dia		1
2	p05393	Barb, 1/4 Hose 1/4NPT		1
3	p851	VALVE, FUEL, IN LINE SHUT OFF		1
4	p649	HOSE CLAMP, 7/32IN-5/8IN		2
5	f05010-10	Nut, 3/8-16 Hex Nyl Lock		3
6	f05011-3	Washer, 3/8 Flat SAE		6
7	f05007-73	Bolt, 3/8-16x3 HH Gr5		3
8	f05011-17	Washer, 5/16 SAE Flat		4
9	f05011-13	Washer, 5/16 Split Lock		4
10	f05006-15	Bolt, 5/16-18x1/2 HH Gr5		4
11	130288	Cover Wldmnt, Fuel Tank, Dometic		1
12	130286	Fuel Tank, Dometic 6 Gal		1
13	103810	Wldmnt, Fuel Tank Tray		1
14	130283	Extension, Fuel Tray		1
15	f05006-86	Bolt, 5/16-18x3/4 Carriage		2
16	f05010-221	Nut, 5/16-18 Flanged Hex Nylock		2
	R02423-1	Hose, Fuel 3/16" EPA 15G CARB		6 Ft
	R02423-2	Hose, Fuel 1/4" EPA 15G CARB		6 Ft

4.2 Engine Assembly

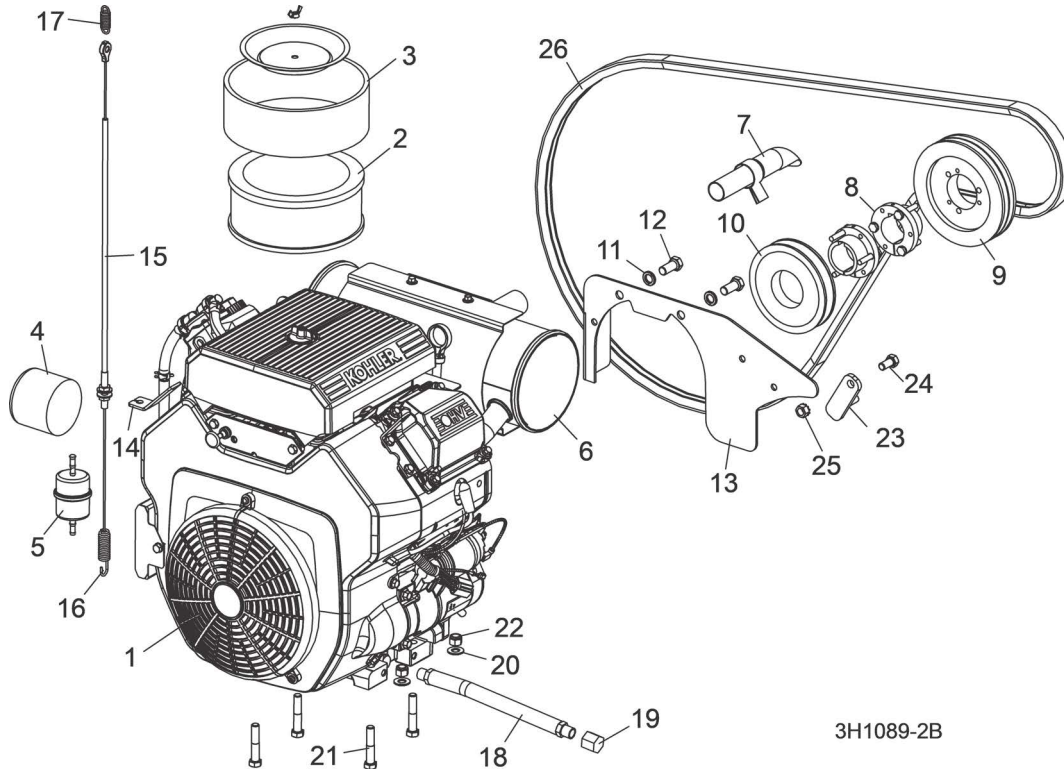

REF	PART #	DESCRIPTION	COMMENTS	QTY.
	015993	MANUAL, KOHLER CH25 OWNER'S		1
	015994	MANUAL, KOHLER CH25 SERVICE		1
	074399	Engine Assembly, LT35 G25 (No Key Switch)		1
1	074350	Engine, 25HP Kohler Gas CH740		1
	016290	Gasket Kit, Kohler CH25 Head #24-757-31		1
	P12734	Filter Kit, Kohler Air/Pre #24-883-03-S1		1
2	P12736	Filter, Kohler Air #24-083-03	Available in assemblies only.	1
3	P12737	Pre Cleaner, Kohler #24-083-05	Available in assemblies only.	1
	P12757	Plug, RC12YC Kohler Spark #12-132-02		2
	016079	Module Kit, Kohler Ignition #KH24-584-11 (Qty. 2)		1
4	014717	Filter, Kohler Oil #52-050-02		1
5	P12758	Filter, Kohler Fuel #24-050-13		1
	061157	Kit, Valve Cover w/ Lift Pump 24 559 10S		1
6	003294	Muffler Assembly, Kohler #24-786-10S		1
7	036684	Arrestor, Kohler Spark #24-18901-S		1
8	016535	Bushing, 1 7/16" SH		2
9	047742	Pulley, 3V5.6 x 2" SH		1
10	062551	Sheave, LT35 Alternator Drive		1
11	F05011-48	Washer, 7/16" Split Lock		2
12	F05007-145	Bolt, 7/16-14 x 1" Hex Head Grade 5		2
13	062553	Plate, LT35 Rear Alt Cover		1
14	047750	Plate, Throttle Cable Mount		1
15	047749	Cable, LT15 G25 Throttle		1

REF	PART #	DESCRIPTION	COMMENTS	QTY.
16	016033	Spring, Throttle		1
17	015952	Spring, Throttle Extension		1
18	P10082	Hose, 3/8" NPT Oil Drain		1
19	P04332	Cap, Oil Drain Hose		1
	016023	Carburetor Kit, 25Hp Kohler Anti-Icing #25-755-65-S		1
	061303	Solenoid, Fuel Shut Off 24-757-01-S		1
20	F05011-3	Washer, 3/8" SAE Flat		4
21	F05007-124	Bolt, 3/8-16 x 2" Hex Head Grade 5		4
22	F05010-10	Nut, 3/8-16 Hex Nylon Lock		4
23	048237	Support Weldment, Drive Belt		1
24	F05007-118	Bolt, 3/8-16 x 3/4" Hex Head Grade 5		1
25	F05010-19	Nut, 3/8-16 Self-Locking Hex		1
26	047751	Belt, 2/3VFL900 Drive		1

4.3 Alternator Assembly

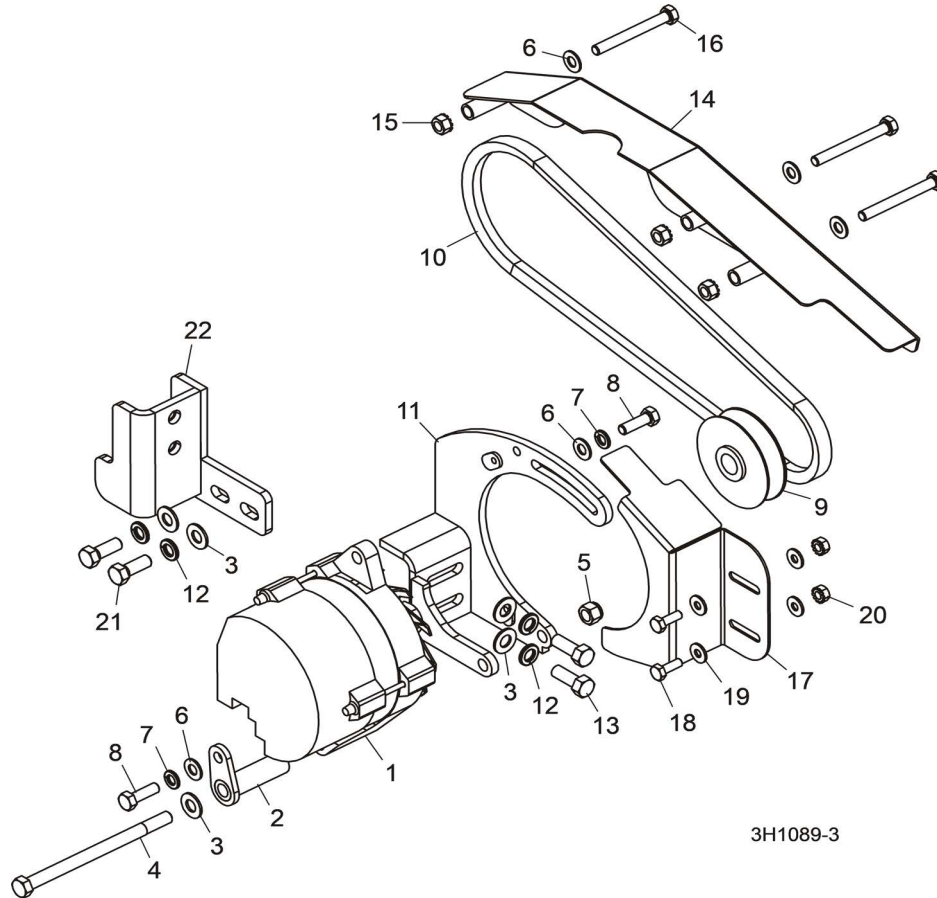

3H1089-3

REF	PART #	DESCRIPTION	COMMENTS	QTY.
1	050287-1	Alternator, 12V 105A		1
2	W12761	Brace, Alternator		1
3	F05011-3	Washer, 3/8" SAE Flat		5
4	F05007-34	Bolt, 3/8-16 x 5 1/2" Hex Head Full Thread		1
5	F05010-10	Nut, 3/8-16 Hex Nylon Lock		1
6	F05011-17	Washer, 5/16" SAE Flat		6
7	F05011-13	Washer, 5/16" Split Lock		2
8	F05004-40	Bolt, M8 X 1.25" X 1" Hex Head Full Thread		2
9	P03806	Pulley, Alternator		1
10	P11542	Belt, A33 Alternator		1
11	014509	Bracket, Alternator Mount		1
12	F05011-4	Washer, 3/8" Split Lock		4
13	F05007-7	Bolt, 3/8-16 x 1" Hex Head		2
14	062556	Cover Weldment, Lt35 Alt Belt		1
15	F05010-20	Nut, 5/16-18 Keps		3
16	F05006-28	Screw, 5/16-18 X 2 3/4" Hex Head Cap Grade 5		3
17	062555	Plate, Lt35 Alt Cover		1
18	F05005-1	Bolt, 1/4-20 X 3/4" Full Thread Hex Head Cap		2
19	F05011-11	Washer, 1/4" SAE Flat		4
20	F05010-9	Nut, 1/4-20 Keps		2
21	F05007-87	Bolt, 3/8-16 X 1" Hex Head Grade 5		2
22	065104	Mount Weldment, Lt35 Alt		1

4.4 Throttle/Clutch Assembly

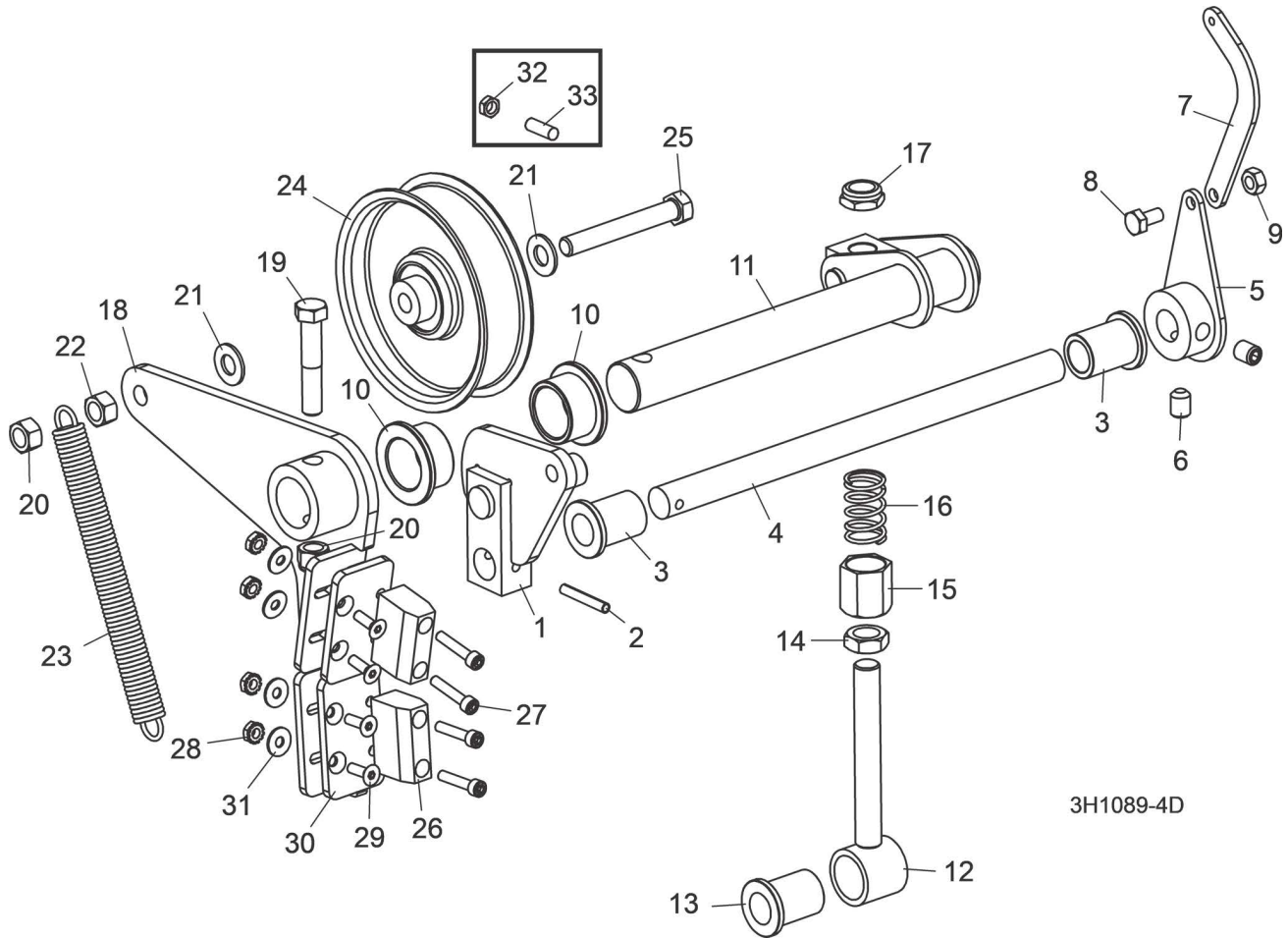

3H1089-4D

REF	PART #	DESCRIPTION	COMMENTS	QTY.
1	065574	BLOCK WELDMENT, LINKAGE CLUTCH/BRAKE		1
2	F05012-16	PIN, 3/16" X 1 1/4" ROLL		1
3	016486	BUSHING, 5/8" ID X 7/8" OD X 1 1/4" LONG FL BRONZE		2
4	049340	SHAFT, LT28 THROTTLE		1
5	034815	ACTUATOR WELDMENT, THROTTLE LT15D&G		1
6	F05007-68	SCREW, 3/8-16 X 3/8" SOCKET HEAD CUP PT SET		2
7	034818	LINKAGE, THROTTLE LT15D&G		1
8	F05005-15	BOLT, 1/4-20 X 1/2" HEX HEAD		1
9	F05010-21	NUT, 1/4-20 SWAGED		1
10	P737	BUSHING, 1" X 1 1/4" X 3/4" FLANGED BRONZE		2
11	034608	PIVOT WELDMENT, CLUTCH/BRAKE		1
	034605	LINKAGE ASSEMBLY, W/BEARING		1
12	034604	Boss Weldment, Clutch/Brake Linkage		1
13	016486	Bushing, 5/8" ID x 7/8" OD x 1 1/4" Long Flanged Bronze		1
	038778	NUT ASSEMBLY, 1/2-13 SPRING LOCKING		1

4 Replacement Parts

Throttle/Clutch Assembly

REF	PART #	DESCRIPTION	COMMENTS	QTY.
14	F05010-31	Nut, 1/2-13 Hex Jam		1
15	038777	Nut, 1/2-13 Spring Lock		1
16	046975	Spring, .72" OD x .576" ID x 1.25L Compression		1
17	F05010-127	Nut, 1/2-13 Half Nylon Lock		1
	065874	BRAKE/CLUTCH ASSEMBLY		1
18	065873	Arm Weldment, Clutch/Brake		1
19	F05007-124	Bolt, 3/8-16 x 2 Hex Head Grade 5		1
20	F05010-10	Nut, 3/8-16 Hex Nyl Lock		2
21	F05011-3	Washer, 3/8" Flat SAE		3
22	F05010-25	Nut, 3/8-16 Swaged		1
23	034810	Spring, Idler Arm LT15/D/E/G		1
24	034602	Idler, 4" O.D. x 3/8" Bore		1
25	F05007-125	Bolt, 3/8-16 x 2-1/2" Hex Head Grade 5		1
26	016488	Block, LT15 Brake		2
27	F05004-2	Bolt, #10-24 x 1" Socket Head Cup		4
28	F05010-14	Nut, #10-24 Keps		8
29	F05004-282	Screw, 10-24 x 5/8" FSHC		4
30	065872	Plate, Brake Adjustment		2
31	F05011-18	Washer, #10 SAE Flat		4
32	F05010-29	NUT, 3/8-16 JAM		1
33	F05007-18	SCREW, 3/8-16 X 1 1/4 SHOP SET		1