

D55 Engine

Safety, Operation, Maintenance & Parts Manual

006494 Assy, 55HP Yanmar Engine (OBS)	rev. J
110141 Assy, Super 70 D55 T4 Yanmar	rev. A

Safety is our #1 concern!

Form #1589

LT70HDD55 (OBS)	rev.B2.00- B6.13
LT70HDD55-RD (OBS)	rev. B4.02 - B6.03
LT70HDD55-RX (OBS)	rev. B2.00 - B4.20
LT70HDD55W (OBS)	rev.B2.00- B6.13
LT70HDD55-WR (OBS)	rev. B2.00 - B4.02
LT70HDD55W-RD (OBS)	rev. B4.02 - B6.03
LT70HDD55W-WR (OBS)	rev. B2.00 - B4.02

LT70HDD55-RH Super	rev. A5.11 - A6.02
LT70HDD55W-RH Super	rev. A5.11 - A6.02

See **Form 2507** for International D55 models



WARNING! Read and understand this manual before using this machine.

California

Proposition 65 Warning



WARNING: Breathing gas/diesel engine exhaust exposes you to chemicals known to the State of California to cause cancer and birth defects or other reproductive harm.

Always start and operate the engine in a well-ventilated area.
If in an enclosed area, vent the exhaust to the outside.
Do not modify or tamper with the exhaust system.
Do not idle the engine except as necessary.

For more information go to www.P65warnings.ca.gov.



WARNING: Drilling, sawing, sanding or machining wood products can expose you to wood dust, a substance known to the State of California to cause cancer. Avoid inhaling wood dust or use a dust mask or other safeguards for personal protection.

For more information go to www.P65Warnings.ca.gov/wood.

Active Patents assigned to Wood-Mizer, LLC

Wood-Mizer, LLC has received patents that protect our inventions which are a result of a dedication to research, innovation, development, and design. Learn more at: woodmizer.com/patents

©2024 Wood-Mizer LLC

Printed in the United States of America, all rights reserved. No part of this manual may be reproduced in any form by any photographic, electronic, mechanical or other means or used in any information storage and retrieval system without written permission from

Wood-Mizer, LLC
8180 West 10th Street
Indianapolis, Indiana 46214

California

Proposition 65 Warning



WARNING: Breathing gas/diesel engine exhaust exposes you to chemicals known to the State of California to cause cancer and birth defects or other reproductive harm.

Always start and operate the engine in a well-ventilated area.
If in an enclosed area, vent the exhaust to the outside.
Do not modify or tamper with the exhaust system.
Do not idle the engine except as necessary.

For more information go to **www.P65warnings.ca.gov**.



WARNING: Drilling, sawing, sanding or machining wood products can expose you to wood dust, a substance known to the State of California to cause cancer. Avoid inhaling wood dust or use a dust mask or other safeguards for personal protection.

For more information go to **www.P65Warnings.ca.gov/wood**.

Active Patents assigned to Wood-Mizer, LLC

Wood-Mizer, LLC has received patents that protect our inventions which are a result of a dedication to research, innovation, development, and design. Learn more at: woodmizer.com/patents

©2023 Wood-Mizer LLC

Printed in the United States of America, all rights reserved. No part of this manual may be reproduced in any form by any photographic, electronic, mechanical or other means or used in any information storage and retrieval system without written permission from

Wood-Mizer, LLC
8180 West 10th Street
Indianapolis, Indiana 46214

SECTION 1 OPERATION

1.1 Starting The Engine (Super).....1-1
 1.2 Starting The Engine (Non-Super).....1-2

SECTION 2 MAINTENANCE

2.1 Safety2-1
 2.2 Engine Oil & Filter.....2-1
 2.3 Cooling System2-1
 2.4 Battery2-2
 2.5 Alternator Belt.....2-2
 2.6 RPM Adjustments (Super)2-2
 2.7 RPM Adjustments (Non-super).....2-2
 2.8 Diesel Particulate Filter (DPF) Information2-4

SECTION 3 REPLACEMENT PARTS

3.1 Fuel/Water Tank Assembly, Super (2017- Present)3-1
 3.2 Fuel/Water Tank, Non-super3-2
 3.3 Fuel/Water Tank, Non-super (2008-2017).....3-4
 3.4 Engine Mount Assembly (2017-Present)3-6
 3.5 Engine Mount Assembly (2008-2017).....3-7
 3.6 Engine Assembly T4 (Super 2017-Present)3-8
 3.7 Engine Assembly T2, T3 (2008 - 2017).....3-10
 3.8 Fuel Pump Assembly.....3-12
 3.9 Drive Assembly (Tier 3).....3-13
 3.10 Drive Assembly (Tier 4).....3-14
 3.11 Electronic Control Unit (ECU - All Except Tier 4)3-15
 3.12 Throttle & Relay Assembly (11/2008 - 8/2017).....3-16
 3.13 ECU Assembly (Tier 4).....3-18
 3.14 Radiator Assembly (Tier 3).....3-20
 3.15 Radiator Assembly (Tier 4).....3-22
 3.16 Alternator Assembly (2/2010-1/2015)3-24
 3.17 Alternator Assembly (11/2008 - 2/2010)3-25
 3.18 Engine Pulley Guards.....3-27
 3.19 Bearing Support (Non-Super).....3-28
 3.20 Bearing Support (Super Tier 3).....3-29
 3.21 Bearing Support (Super Tier 4).....3-30
 3.22 Flywheel Cover Assembly (Super Only)3-31
 3.23 Drive Belt Guard Assembly3-32

SECTION 1 OPERATION

1.1 Starting The Engine (Super)

Engine Control Indicators



Battery Indicator: Shows the current battery voltage.



Engine Oil Pressure Indicator: Icon turns red when there is no oil pressure.



Engine Water Temperature Indicator: Shows the current engine temperature. Icon turns yellow when temperature is between 215F-225F (102C-107C). Icon turns red when temperature is above 225F (107C).



Cold Start Device Indicator: Shows when the air heater is running.



Engine RPM Indicator: Shows the current engine RPM.

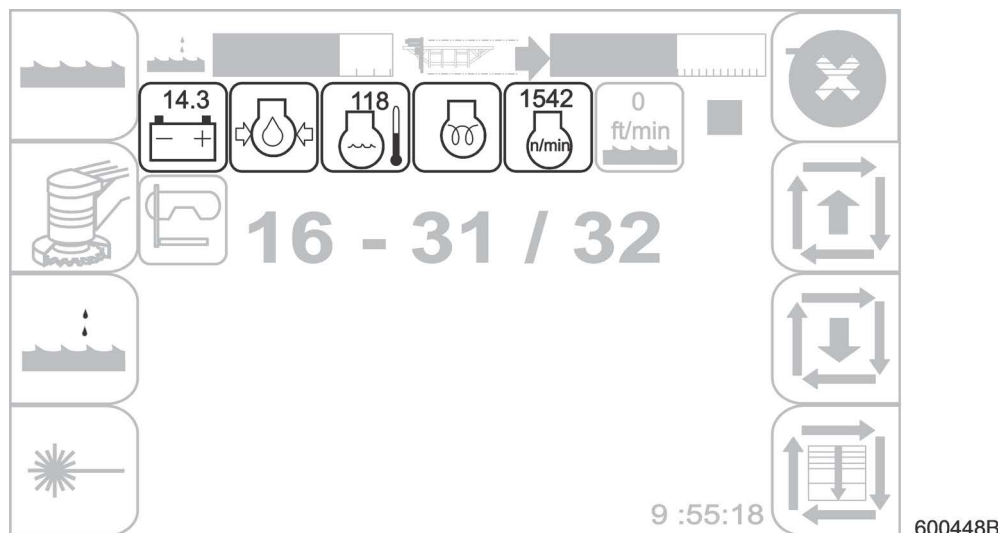

FIG. 1-1

ENGINE START



DANGER! Always be sure the blade is disengaged and all persons are out of the path of the blade before starting the engine. Failure to do so will result in serious injury.

DANGER! Operate your engine/machine only in well ventilated areas. The exhaust gases of your engine can cause nausea, delirium and potentially death unless adequate ventilation is present.

DANGER! Never operate an engine with a fuel or oil leak. The leaking fuel or oil could potentially come in contact with hot surfaces and ignite into flames.



WARNING! Be sure the joystick is in the neutral position before turning the key switch to the on (#1) or accessory (#3) position. This prevents accidental carriage movement, which may cause serious injury or death.

WARNING! Do not operate engine without proper and operational spark arrester/muffler. Sparks emitted from the engine exhaust could ignite surrounding materials, causing serious injury or death.



CAUTION! Do not crank starter for more than 15 seconds at one time during starting attempts. Allow the starter motor to cool for 2 minutes before cranking the starter again. Damage to the engine may result.

CAUTION! Let engine idle for 3 - 5 minutes before applying load to prevent engine damage.

1. See the engine manufacturer's manual for lubricating oil recommendations for specific temperature ranges.
2. Use #2 or better quality diesel fuel for above freezing starting. Use a #1 quality diesel fuel for below freezing starting.
3. Turn the key switch on the control panel to the on (#1) position.
4. Wait for the air heater to finish heating up as indicated on the screen.
5. Be sure all persons are clear of the blade and turn the key switch to the start (#2) position and release.
6. Turn the key switch to the start (#2) position and release.

ENGINE SHUTOFF

 **CAUTION!** A minimum 2 minute idle time is recommended to allow the battery charge to recover and to give the engine turbocharger time to spin down before the engine is shut off.

7. Turn the key switch to the off (#0) position.

1.2 Starting The Engine (Non-Super)

ENGINE CONTROL LIGHTS



Alternator Charge Indicator: Lights up if the alternator is not charging the battery.



Engine Temperature Indicator: Lights up if the engine is overheating. A circuit breaker assembly in the engine harness will shut the engine off if the engine overheats. Turn the key switch off and allow the engine to cool for a period of time before restarting. If the overheating condition persists, stop operating the engine until the condition is corrected. The engine will automatically switch to low idle if an overheating condition occurs.



Key Switch Indicator: Lights up when the key is in either the on or accessory (#1 or #3) position.



Oil Indicator: Lights up if the oil pressure is too low. The engine will automatically switch to low idle if a low oil condition occurs.



Glow Plug Indicator: Lights up after the key has been turned to the on (#1) position.

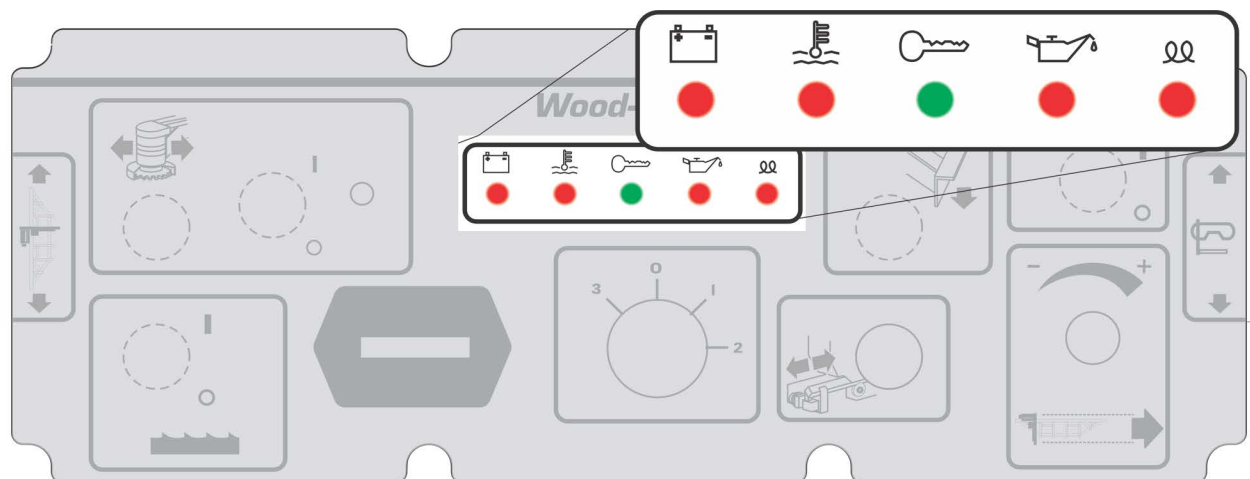

FIG. 1-2

ENGINE START



DANGER! Always be sure the blade is disengaged and all persons are out of the path of the blade before starting the engine.

Operate your engine/machine only in well ventilated areas. The exhaust gases of your engine can cause nausea, delirium and potentially death unless adequate ventilation is present.

Never operate an engine with a fuel or oil leak. The leaking fuel or oil could potentially come in contact with hot surfaces and ignite into flames.



WARNING! Be sure the power feed switch is in the neutral position before turning the key switch to the on (#1) or accessory (#3) position. This prevents accidental carriage movement, which may cause serious injury or death.

Do not operate engine without proper and operational spark arrester/muffler. Sparks emitted from the engine exhaust could ignite surrounding materials, causing serious injury or death.



CAUTION! Do not crank starter for more than 20 seconds at one time during starting attempts. Allow the starter motor to cool for 2 minutes before cranking the starter again.

Let engine idle for 3 - 5 minutes before applying load to prevent engine damage.

1. See the engine manufacturer's manual for lubricating oil recommendations for specific temperature ranges.
2. Use #2 or better quality diesel fuel for above freezing starting. Use a #1 quality diesel fuel for below freezing starting.
3. Engage the blade handle to place the throttle in high position.
4. Turn the key switch on the control panel to the on (#1) position.
5. Be sure all persons are clear of the blade and turn the key switch to the start (#2) position and release.
6. Disengage the blade lever to place the throttle in low idle position and allow the engine to idle for 3-5 minutes.

ENGINE SHUTOFF



CAUTION! A minimum 2 minute idle time is recommended to allow the battery charge to recover before the engine is shut off.

Turn the key switch to the off (#0) position.

SECTION 2 MAINTENANCE

Refer to the manufacturer's manual for maintenance intervals and procedures unless otherwise instructed in this manual. Follow the manufacturer's recommendations for dusty conditions.

NOTICE This manual only provides information about additional procedures or procedures to be performed at different time intervals than found in the manufacturer's manuals. Refer to the manufacturer's manual for complete maintenance instructions.



WARNING! Clean sawdust from all guards, vents, control boxes, or any area where sawdust may gather **after every shift**. Failure to do so may result in fire, causing death or serious injury.



2.1 Safety

Use caution when performing maintenance or service to the engine.



DANGER! Always be aware of and take proper protective measures against rotating shafts, pulleys, fans, etc.

Stay a safe distance from rotating members making sure that loose clothing or long hair do not engage rotating members resulting in possible injury.

Avoid contact with any part of a hot engine. Allow the engine to cool sufficiently before beginning any service function.



WARNING! Remove the blade before performing any engine service. Failure to do so may result in serious injury.

Always wear proper safety equipment (eye, breathing, hand, and foot) when performing service functions.

2.2 Engine Oil & Filter

Check the oil level every 8 hours of operation. Add oil as necessary. See the engine manual for oil viscosity and grade recommendations.



CAUTION! Operating the engine with water in the engine oil will cause severe damage to the engine. Follow all maintenance procedures for checking oil level and oil/filter change intervals.

When checking the oil level, inspect the oil for indications of water in the oil. ***If there is water present or the oil is cloudy:***

1. DO NOT start the engine.
2. Replace the oil and oil filter.
3. Run the engine at low idle for no more than 2 minutes.
4. Replace the oil and filter again.

NOTICE Engines are equipped with a muffler rain cap to keep water out of the muffler and engine. If the sawmill is stored outside or transported during rainy weather, the muffler must be covered. The rain flap is available for previous revision sawmills

Change the engine oil and oil filter **every 250 hours** of operation.

2.3 Cooling System

Clean the radiator fins **every 8 hours** of operation.

Spray the radiator with water from a hose or compressed air to clean sawdust from the radiator fins.

Do not use a pressure sprayer.



CAUTION! Failure to keep the radiator fins clear of sawdust and/or dirt may cause the engine to overheat resulting in damage to the engine.

2.4 Battery

Check the battery electrolyte level **every 50 hours** of operation. See manufacturer's manual for instructions.



DANGER! Batteries expel explosive gases. Keep sparks, flames, burning cigarettes, or other ignition sources away at all times. Always wear safety goggles and a face shield when working near batteries. Failure to do so will cause serious injury.



WARNING! Battery posts, terminals and related accessories contain lead and lead compounds, chemicals known to the State of California to cause cancer and reproductive harm. Wash hands after handling.

2.5 Alternator Belt

The alternator belt is self-tensioning and should not need adjustment. If the battery continues to not charge properly or the belt continues to squeal after the initial belt adjustment, replace the belt.

1. Release the blade tension and remove the blade from the sawmill if necessary.
2. Turn the key switch to OFF (0) and remove the key.
3. Remove the drive belt cover and alternator cover.
4. Pry the belt idler up and remove the belt from the alternator and engine pulleys.
5. While holding the idler up, install the new belt around the alternator and engine pulleys.
6. Release the idler on top of the belt and reinstall the alternator and drive belt covers.

2.6 RPM Adjustments (Super)

The Yanmar D55 Engines that include the electronic controls and do not require any RPM adjustment.

2.7 RPM Adjustments (Non-super)



WARNING! Remove the blade before performing any engine service. Failure to do so may result in serious injury.

Check the RPM with a tachometer **every 200 hours** of operation. High-end RPM should be 2800 RPM and low-end RPM should be 1500 RPM.

1. Ensure belt and brake strap tensions are correct (See Sawmill Maintenance).
2. Check oil, fuel, and coolant levels.
3. Ensure the throttle solenoid linkage is adjusted properly.

With the clutch disengaged, the throttle linkage should rest against the idle adjustment screw. With the clutch engaged, the linkage should rest against the high-end adjustment screw and leave 0" to 1/32" of play in the linkage.



CAUTION! Failure to properly adjust the throttle solenoid linkage may cause damage to the solenoid.

1. Adjust the throttle solenoid linkage by disengaging the clutch and loosen the solenoid mounting bolts.
2. Adjust the solenoid as far to the right as possible and retighten the mounting bolts.
3. Engage the clutch and recheck the amount of play in the linkage.

If there is more than $1/32$ " of play in the linkage with the clutch engaged, disengage the clutch and turn the linkage turnbuckle.

4. Repeat adjustments to achieve 0 "- $1/32$ " of play in the linkage with the clutch engaged.

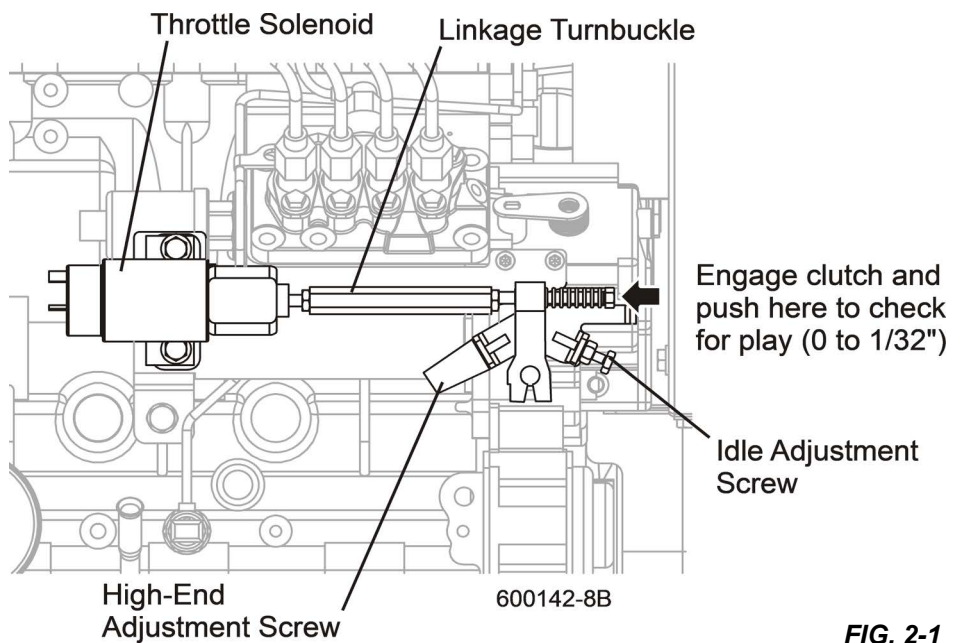
**FIG. 2-1**

5. Start the engine to measure the low-end RPM.
6. Let idle for 10 minutes.
7. Check the low-end RPM with the engine still at idle.
8. Adjust to 1500 RPM.
9. To decrease speed, loosen the idle adjustment screw. To increase speed, tighten the idle adjustment screw. The high-end adjustment screw should not be adjusted.
10. After the RPM settings are made, shut the engine off.

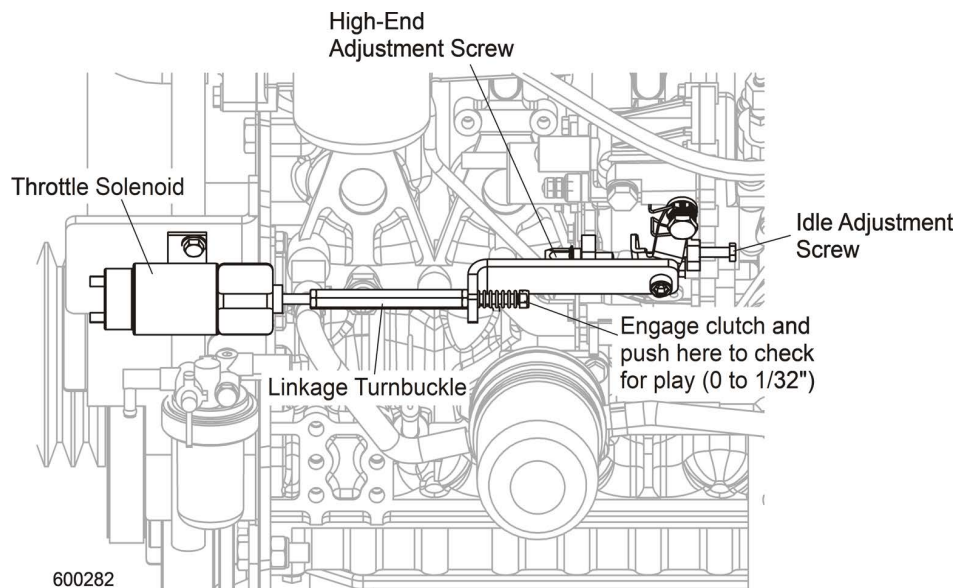
**FIG. 2-2 REV. B2.00 TO B3.02**

2.8 Diesel Particulate Filter (DPF) Information

(Information provided by the Yanmar Application Manual ODTN4-EN0041 Rev.01 unless it is specific to the Wood-Mizer Control)

Role of the DPF System

The diesel particulate filter (DPF) system is implemented in automobile diesel engines. It uses a soot filter (SF) to collect particulate matter (PM) from the exhaust gas and safely processes it. Application of the DPF system complies with the Tier 4 emission standards set by the United States Environmental Protection Agency and the emission standards set by other countries.

Structure of All Devices

Structure of the DPF

The DPF consists of the diesel oxidation catalyst (DOC), the soot filter (SF), and the DPF case. The DPF case includes the DOC and SF and leads the exhaust gas into them.

DOC	Ceramic carrier with catalyst coating.
SF	Ceramic. The exhaust gas is passed through the ceramic wall by alternately closing the channels. The PM is collected while passing through the wall.
DPF case	Stainless steel. The DOC is divided into the DOC case and the silencer room. (Some applications have an outlet flange only.) Each part is bolt-tightened to the body flanges. Do not use the DPF case after you drop it. The ceramic DOC and SF are fragile and can break.
Mat	Ceramic fiber. The mat holds the ceramic DOC and the SF in the metal case.

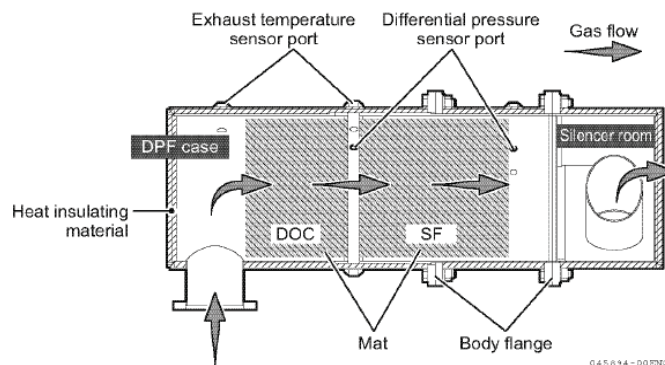

Function of the DPF

The function of the DPF is to break down harmful substances in the DOC and to collect particulate matter in the SF, thus preventing the release of contaminants into the atmosphere. Particulate matter that accumulates in the SF of the DPF causes it to clog, reducing engine performance. Therefore it is necessary to burn off the accumulated PM. There are 3 incineration methods: continuous regeneration, intermittent regeneration, and additive regeneration. YANMAR engines use a continuous regeneration method, which allows the collection and at the same time incineration of particulate matter inside the DPF while continuing engine operation.

DPF exhaust temperature sensor

The DPF exhaust temperature sensors are directly fastened to the sensor ports (one in the front and one in the back of the DOC) installed in the DPF periphery.

DPF differential pressure sensor

The DPF differential pressure sensor is installed through the stay in the DPF flange and connected with the steel pipe attached to the DPF and rubber tube.

Precautions for Use (Precautions for Users)

- Fuel: Use light oil with a sulfur content (mass) of 15ppm or less (ultra-low sulfur) for DPF engines.
If you use other than the specified fuel, sulfur will rapidly deteriorate the catalyst performance inside the DOC. When the regeneration performance of the DPF is inhibited and more particulate matter accumulates, the drop of engine output and the frequent switches to regeneration mode increase fuel costs and worsen the engine condition.

- Lubricating oil: use a low-ash oil as lubricating oil. If you use a different lubricating oil than specified, a large amount of ash is vented through the exhaust, and the DPF will clog quickly. This will not only cause the engine output to decrease and fuel costs to increase, but will also make frequent maintenance of the SF necessary.
- Precautions when performing the stationary regeneration.
 - Ventilate well.
 - If avoidable, do not perform the stationary regeneration in a closed place such as a storage shed.
 - Regeneration causes the temperature around the tail pipe to increase.
 - Make sure there are no flammable materials or people nearby.
- If your engine is equipped with DPF cleaning alarm, clean the DPF when the alarm lamp comes on. If your engine is not equipped with DPF cleaning alarm, clean the DPF every 6000 hrs of operation.
- As the DPF is subject to emission regulations, disassembly by the user is prohibited. If a repair is required, consult a specialized service shop.
- Refer to the service manual for maintenance methods and intervals regarding ash removal.
- The smell of the exhaust gas from the DPF is different from that of a conventional engine. This is not a defect.
- White smoke may come out of the tail pipe during starting. This is water vapor and not problematic.
- If the operation requires waiting time with low-idle rather than actual traveling, DPF regeneration at normal operation may be difficult to operate. Therefore the stationary regeneration may need to be done more often.

Diesel Particulate Filter (DPF) System Control Overview



Overview

YANMAR's DPF system continuously burns particulate matter that accumulates on the SF (soot filter). This is called DPF regeneration.

Electrical equipment such as the DPF differential pressure sensor, temperature sensor and intake air throttle are installed to the DPF. If the DPF can not continue to regenerate while operating at low load, the E-ECU automatically assist the DPF regeneration (DPF regeneration assistance) using the electrical equipment and avoiding accumulation of particulate matter.







The table below shows the outline of DPF regeneration assistance. YANMAR uses an original DPF regeneration method that combines regeneration by the regeneration assistance devices (intake air amount control by the intake air throttle and extension of the injection timing by the common rail) and regeneration by the common rail multi-step injection (post-injection by the common rail).







Terminology	Control content	Explanation	Remarks
Self regeneration	Regeneration without regeneration assist unit (normal)	In a high speed and high load operation, the exhaust temperature rises and PM are burnt and removed continuously.	There regenerations can be performed during operation. No operator intervention is needed.
Assisted regeneration	Regeneration with regeneration assist unit.	In a low speed and low load operation, the exhaust temperature is too low for continuous regeneration.	
Reset regeneration	Regeneration with assist regeneration and post injection.	Therefore the E-ECU automatically performs the regeneration controls shown on the left to increase the exhaust temperature and burn/remove PM.	





Terminology	Control content	Explanation	Remarks
Stationary regeneration	<p>Regeneration with more effective reset regeneration and automatic control to engine speed suitable for DPF regeneration</p>  <p>DPF Regen Req lamp</p>  <p>Trouble Lamp</p>	<p>In a low speed/low load operation continuing long time, the assist regeneration/reset regeneration may not be enabled because the exhaust temperature does not rise sufficiently. If the PM deposit amount reaches a certain level in this situation, the DPF Regen Req lamp and Trouble lamp illuminate. At that time, the operator can start the stationary regeneration to burn/remove PM by operating the DPF regeneration request switch.</p>	<p>When DPF Regen Req lamp illuminates, the operator should move the machine to a safe place without any flammable matters nearby before operating the stationary regeneration.</p> <p>Do not perform any working operation because a special control dedicated to DPF regeneration takes place.</p>

DPF regeneration and operator interface

Specifications of each DPF regeneration and operator interface.

	Name	Specification
Input	Regeneration interlock switch	<p>Because the engine ECU changes the target speed automatically in stationary regeneration, it is necessary to inform the engine ECU that the interlock is enabled.</p> <p>Once you are on the DPF regeneration screen, high throttle is disabled. You must then engage the Auto-clutch with the joystick before the Interlock switch can be turned on. Once the Interlock switch is turned on the throttle will idle down to 800 RPM in order to permit stationary regeneration.</p>
	 Interlock off	
	 Interlock on	
	DPF regeneration request switch	Used for starting manual stationary regeneration.
	 Unpressed	
	 Pressed	
DPF regeneration inhibit switch	<ul style="list-style-type: none"> Used for inhibiting manual reset regeneration. Used for interrupting reset/stationary regeneration. <p>It is recommended to have regeneration inhibited so that the operator can choose when to run reset/stationary regeneration. You do not want reset/stationary regeneration to run when you are in an enclosed space or around flammable materials. The exhaust system will get extremely hot during reset/stationary regeneration.</p>	
 Uninhibited		
 Inhibited		

	Name	Specification
Output	Failure lamp	Used for notifying operators of the following status.
	 Off	Flash When stationary regeneration standby in the emergency condition, during the backup mode, and the ash cleaning is required. When there is an active DTC from any ECU on the sawmill.
	 On	
	DPF Regen inhibit lamp	Used for notifying operators that reset/stationary regeneration is in "inhibited" state.
	 Off	On While DPF regeneration inhibit switch is in "Regeneration inhibited" state
	 On	
	DPF Regen Req lamp	Used for notifying operators of reset/stationary regeneration standby status to prompt operators to start regeneration and also notifying operators that stationary regeneration is in process.
	 Off	On -- While DPF regeneration inhibit switch is in "Regeneration inhibited" state, when stationary regeneration is permitted (50h have passed since the last reset or last stationary regeneration.) -- During stationary regeneration standby or in back up mode
	 On	
		Flash

	Name	Specification	
Output	DPF Regen Ack lamp	Used for notifying operators of reset/stationary regeneration standby status to prompt operators to start regeneration and also notifying operators that stationary regeneration is in process.	
	 Off	On -- Stationary regeneration is in process -- For 3 seconds after DPF regeneration request switch is pressed and held	
	 On		
		Flash	-- During reset regeneration standby (DPF regeneration inhibit switch is in "Regeneration inhibited" state), when regeneration interlock switch is in "Regeneration permitted (interlock enabled)" status -- During stationary regeneration standby or backup mode, when DPF regeneration inhibit switch is in "Regeneration permitted" status and regeneration interlock switch is in "Regeneration permitted (interlock enabled)" status
	EGT lamp	Used for notifying operators of high exhaust temperature caused by reset/stationary regeneration.	
	 Off	On Reset/stationary regeneration is active.	
 On			

DPF regeneration inhibit switch is set to “Regeneration permitted” state.

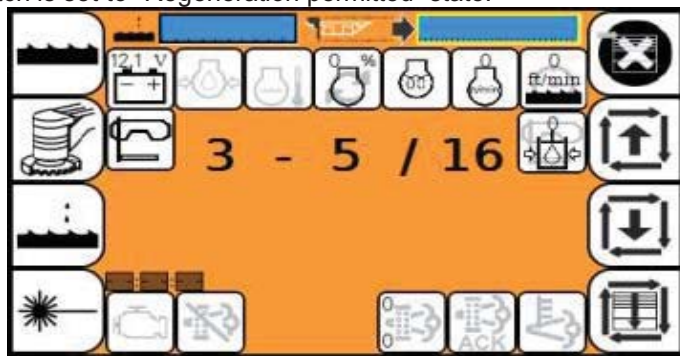

○ Regeneration Req lamp explanation.

○ (1) DPF regeneration mode status

- 0 = Normal operation
- 1 = Assist regeneration
- 2 = Reset regeneration
- 3 = Stationary regeneration

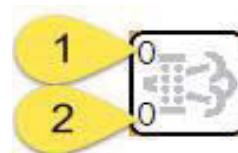

○ (2) DPF regeneration control status

- 0 = Normal operation or notification of DPF regeneration control
- 1 = Start of automatic speed control by ECU (gradually acceleration)
- 2 = +After injection and retard, intake throttle operation (target position limitation)
- 3 = +Intake throttle operation (no limitation of target position)
- 4 = +Post injection (phase 1)
- 5 = +Judgement of finishing the DPF regeneration (start of judgement by the DPF middle temperature)
- 6 = +Post injection (phase 2)
- 7 = +Judgement of finishing the DPF regeneration
- 8 = +Finish of automatic speed control by ECU (gradually deceleration)
- 9 = +Accumulation value reset

● When the DPF regeneration inhibit switch is set to “Regeneration inhibited” state.

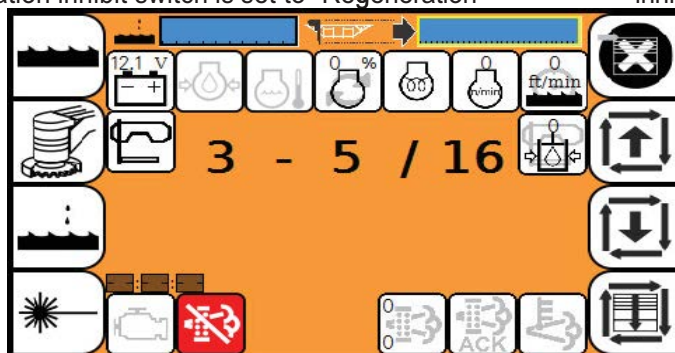

○ To set the DPF regeneration inhibit switch to “Regeneration inhibited”, go to the “User Configuration” screen by pressing the “Function Key” on the HMI.



○ On the “User Configuration” screen, turn the “Encoder” on the HMI, to highlight “DPF Regeneration”, then press the “Encoder” to go to the “DPF Regeneration” screen.



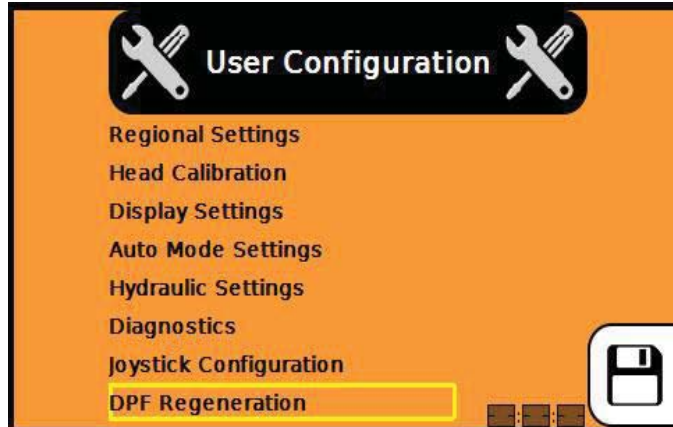

- On the “DPF Regeneration” screen, press the bottom left “Soft Key”, shown below, to set the regeneration inhibit switch to “Regeneration inhibited”.

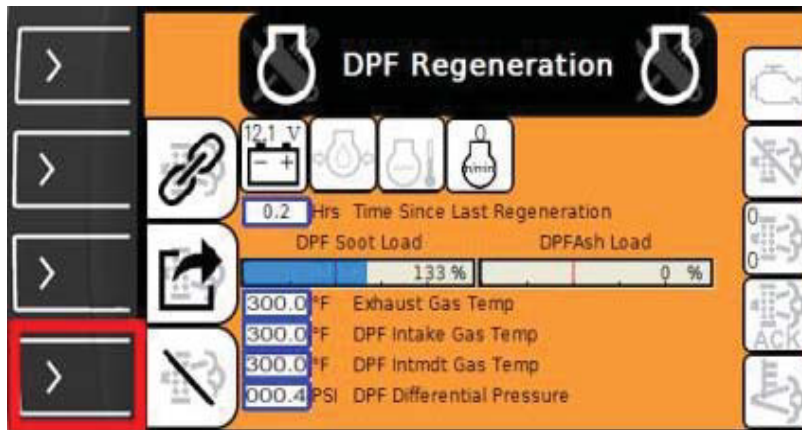

- When the regeneration inhibit switch is set to “Regeneration inhibited”, the “DPF Regeneration” screen will look like the image below.

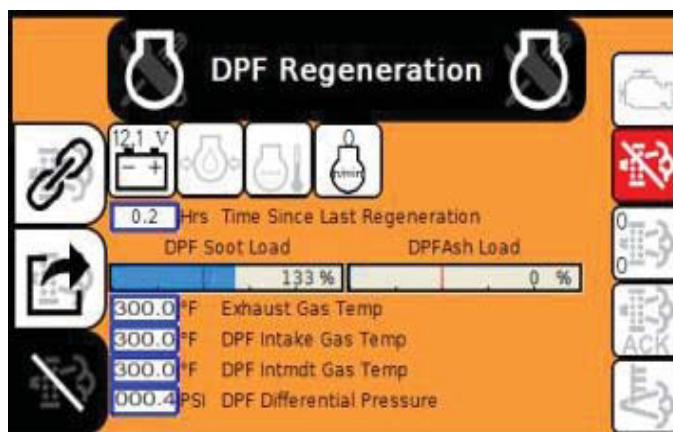

When 50 hours have passed since the last reset/stationary regeneration, DPF transfers to the state [2] or [3] described below.

[2] Self regeneration (normal operation) and assist regeneration operating (Elapsed time since last reset: 50 hours or more, regeneration inhibited state)

- When 50 hours have passed with the DPF regeneration inhibit switch set to “Regeneration inhibited” state since the last reset/stationary regeneration, the DPF Regen Req lamp illuminates. This means that stationary regeneration execution is permitted. According to the need for stationary regeneration, set the DPF regeneration inhibit switch to “Regeneration permitted” state and perform operation [3] described below.



- When 100 hours have passed since the last reset, DPF transfers to the reset regeneration standby state [5] described later.

[3] Self regeneration (normal operation) and assist regeneration operating (Elapsed time since last reset: 50 hours or more, no regeneration inhibition)

- When 50 hours have passed since the last reset, stationary regeneration execution is permitted.

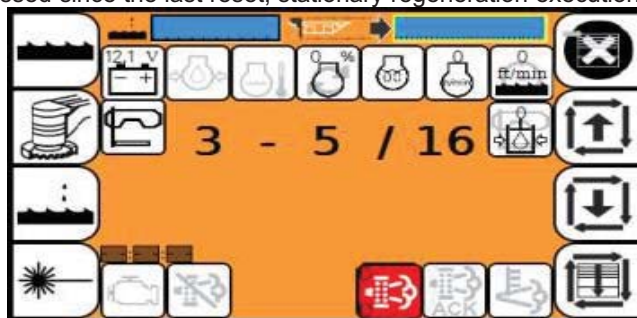

- At that time, setting the interlock switch to “Regeneration permitted” state and holding the DPF regeneration SW to “ON” state for 3 seconds or more causes the DPF to transfer to the stationary regeneration standby state [6] described later. For the operation method after stationary regeneration standby state, refer to [6] described later.

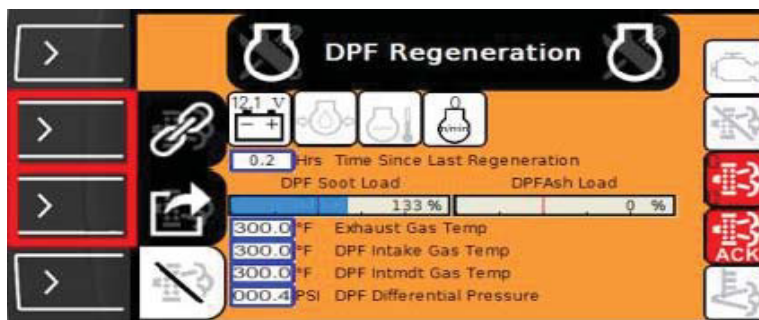

- When 100 hours have passed since the last reset, reset regeneration is started automatically, transfer to [4] described below.

[4] Reset regeneration operating (Elapsed time since last reset: 100hours, no regeneration inhibition)

- The reset regeneration is completed in approximately 25 to 30 minutes.



- After the reset regeneration completion, DPF transfers to [1] described above.
- When the DPF regeneration inhibit switch is set to “Regeneration inhibited” state, the reset regeneration stops and DPF transfers to the reset regeneration standby state [5] described later.

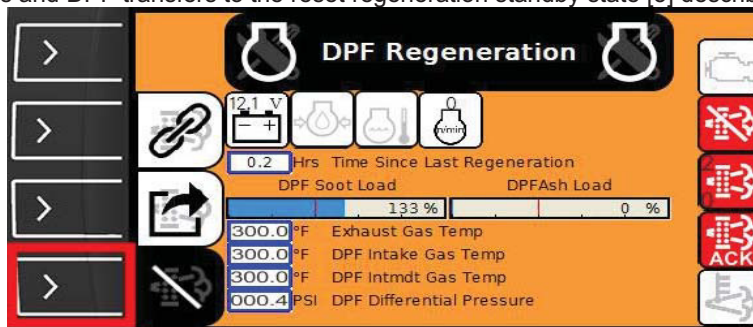

- Regeneration request lamp blinks
- Regeneration acknowledge lamp blinks
- As in [3] described above, setting the interlock switch to “Regeneration permitted” state and holding the DPF regeneration request switch to “ON” state for 3 seconds or more causes the DPF to transfer to the stationary regeneration standby state [6] described later.

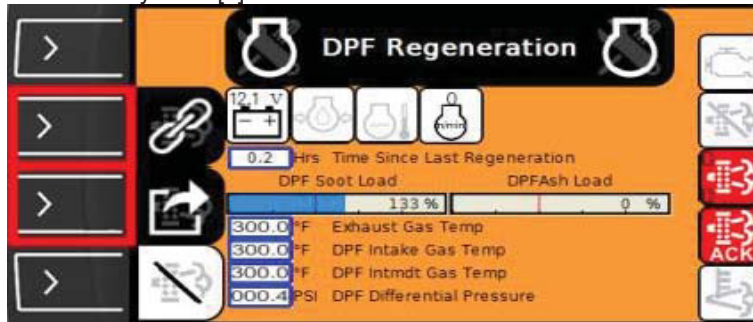

[5] Reset regeneration standby (Elapsed time since last reset: 100hours, regeneration inhibited state)

- While the DPF regeneration inhibit switch is set to “Regeneration inhibited” state, the reset regeneration is stopped.

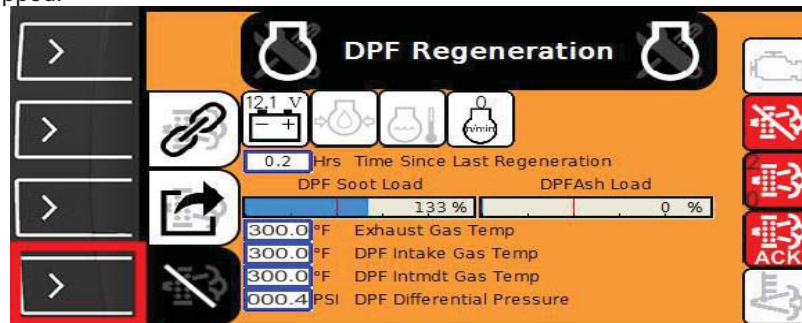

- Regeneration request lamp blinks
- Regeneration acknowledge lamp blinks
- When 1 hour has passed in the reset regeneration standby state, DPF automatically transfers to the stationary regeneration standby state [6] described below. For details on the stationary regeneration standby, refer to [6] described below.
- If the PM deposit amount decreases by a certain amount in the reset regeneration standby state, the reset regeneration ends automatically and transfers to the normal operation [1] described above.

[6] Stationary regeneration standby

- An operator intervention ([3], [4] above) (hereinafter referred to as “Allow state”) or detection of certain PM deposit amount or more (hereinafter referred to as “Emergency state”) causes the DPF to transfer to the stationary regeneration standby.
- When the transition is made from the above “Allow” condition to the stationary regeneration standby, only the regeneration request lamp is turned on.



- When the transition is made from the above “Emergency” condition, the DTC, SPN 3719 – DPF Operator Interface, FMI 16 – Stationary regeneration standby, is displayed.

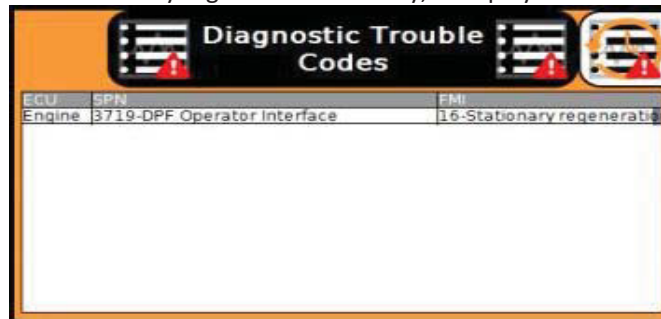

- Press the “Esc” key code  on the HMI to back to the screen that was active before the appeared.
- Regeneration request lamp turns on and the failure lamp blinks.

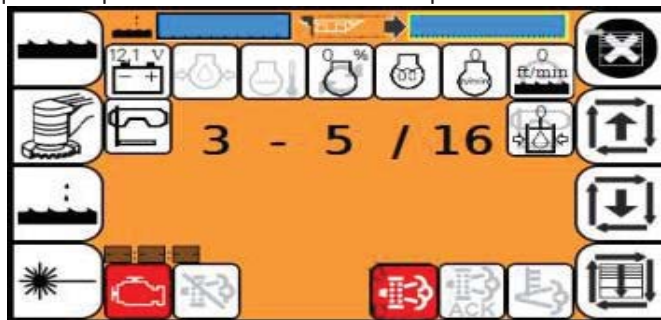

- Make sure to refer to *Stationary regeneration execution on page ###* and confirm the operation procedures and precautions for the interlock switch and DPF regeneration request switch before starting stationary regeneration, transfer to [7] described later.
- If a certain length of time elapses AND the PM deposit amount reaches to or above a certain level, DPF automatically transfers to the backup mode [8] described later.

[7] Stationary regeneration operating

- The stationary regeneration is completed in approximately 25-30 minutes. After the stationary regeneration completion, DPF transfers to [1] described above.



- If the stationary regeneration has started in the Allow state, setting the DPF regeneration inhibit SW to “Regeneration inhibited” state interrupts the stationary regeneration and DPF transfers to the state [2] described above. On the other hand, when the interlock switch is set to “Nonrenewable” state while the DPF regeneration inhibit switch is set to “Regeneration permitted” state, the stationary regeneration is interrupted and the DPF transfers to the state [3] described above.
- If the stationary regeneration has started in Emergency state, any of the following operations interrupts the stationary regeneration and DPF transfers to stationary standby state [6] described above.
 - Set DPF regeneration inhibit switch to “Regeneration inhibited” state
 - When the interlock switch is turned to the “Regeneration prohibition” condition
 - Command an accelerator position equal to or more than the minimum position
 - Turn key switch to OFF

[8] Backup mode

- In backup mode, the engine is operated with speed limit and/or max. injection amount limit.



- In backup mode, DTC for the relevant factor as listed below is displayed along with the specified DTC, SPN 3719 – DPF Operator Interface, FMI 0 – Back up mode.
 - If the PM deposit amount (C method) is equal to or larger than a certain amount, DTC, SPN 522573 – DPF, FMI 0 – Over accumulation (C method)
 - If the PM deposit amount (P method) is equal to or larger than a certain amount, DTC, SPN 522574 – DPF, FMI 0 – Over accumulation (P method)
 - If the PM deposit amount is equal to or larger than a certain amount even after stationary regeneration has been executed for a specified time, DTC, SPN 522575 – DPF, FMI 7 – Regeneration defect (stationary regeneration failed)
 - If a certain length of time elapses in stationary regeneration standby state, DTC, SPN 522577 – DPF, FMI 11 – Regeneration defect (stationary regeneration not operated)
- To cancel the backup mode, you need to use the service tool (SA-D).

Stationary regeneration execution

Even when the engine ECU performs assist regeneration or reset regeneration, PM may not be burnt (DPF may not be regenerated) if idling with no load or operation with low speed/load is repeated frequently. At that time, if the engine ECU judges that stationary regeneration should be executed, it illuminates the DPF Regen Req lamp and Trouble lamp. When the DPF Regen Req lamp illuminates, the engine ECU needs to control the engine speed automatically to perform a process of burning PM, stationary regeneration. Continued operation with the DPF Regen Req lamp illuminated allows PM to accumulate excessively and may cause an abnormal burning of PM, resulting in DPF damage or fire. Therefore, perform stationary regeneration by operating the regeneration interlock switch and the DPF regeneration request switch according to the procedure below. When starting stationary regeneration in such a situation, you should basically activate the interlock function by operating the interlock switch. When performing stationary regeneration, follow the precautions listed below.

Safety precautions

- Do not do a stationary regeneration in a badly ventilated location. There is the danger of carbon monoxide poisoning.
- Make sure that there are no flammables near the exhaust pipes to avoid fires.
- Do not touch the exhaust pipes during stationary regeneration to avoid injury. Make sure that there are no people close to the exhaust pipes.
- After stationary regeneration starts, white smoke may be discharged from the exhaust pipe. This is not a fault but steam discharged when the exhaust temperature is low. As the exhaust temperature increases, the white smoke will disappear.
- Stationary regeneration may not operate while the engine is cold. Start it after the engine is warmed up.
- The exhaust gas has a different odor from that of a conventional diesel engine. This is not a fault. The different odor is generated because the exhaust gas is purified by the catalyst integrated in DPF.

Operating procedures for stationary regeneration

1. Move to a safe location that is well-ventilated.

2. Go to the “User Configuration” screen by pressing the “Function Key” on the HMI.



3. On the “User Configuration” screen, turn the “Encoder” on the HMI, to highlight “DPF Regeneration”, then press the “Encoder” to go to the “DPF Regeneration” screen.



4. Engage the Auto-clutch with the joystick. While on the “DPF Regeneration” screen, high throttle is disabled.

5. If the Regeneration inhibit switch is set to “Regeneration inhibited” state:

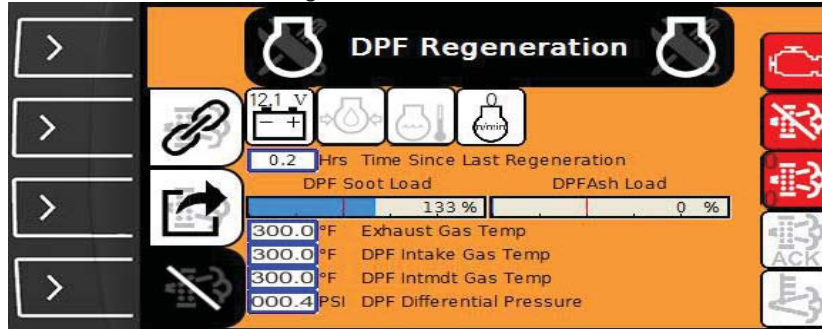

- a. Press the bottom left soft key to set it to the “Regeneration permitted” state.

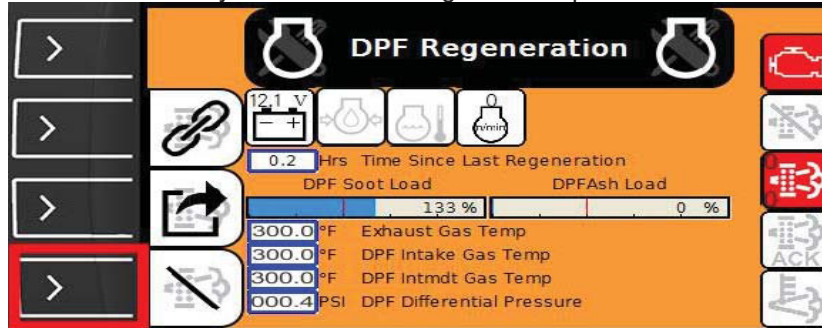

6. Engage the Auto-clutch to prevent the belt from slapping around during regeneration because the engine RPM will raise.
 a. You cannot set the interlock switch, shown below, until the auto-clutch is engaged.
7. Set the Interlock switch to the “Regeneration permitted” state, by pressing the 2nd left soft key.

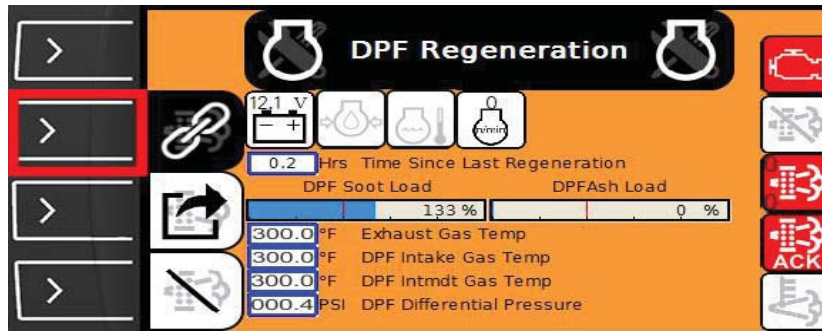

- a. The engine throttle will lower to 800RPM once the Interlock switch is set to the “Regeneration permitted” state.
 b. The Regen Ack lamp flashes.
8. Press and hold the 3rd left soft key for the Regen request switch, for 3 seconds, stationary regeneration starts.
 a. When stationary regeneration starts, the engine speed will gradually increase to high idle speed and reset regeneration will be performed under this operation condition.

- b. When stationary regeneration starts, the DPF Req lamp turns off, Trouble lamp turns off, the DPF Regen Ack lamp changes from flashing to constant illumination, and the EGT lamp illuminates.

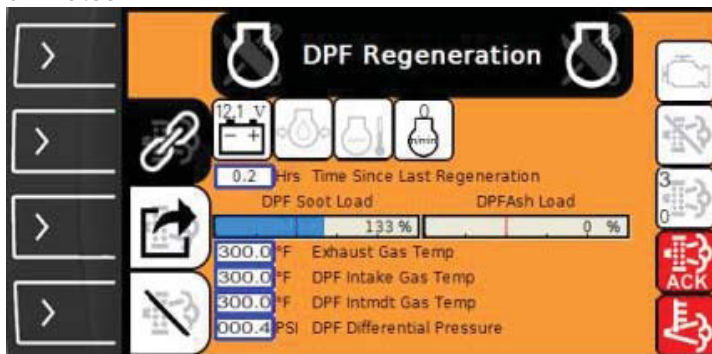

- c. The stationary regeneration will be finished after approximately 25-30 minutes.
 - d. To abort the stationary regeneration, perform either of the following operations.
 - i. Set the interlock switch to “Nonrenewable” state.
 - ii. Set the DPF regeneration switch to “Regeneration inhibited” state.
 - iii. Turn the key switch to OFF.
9. When the above time has passed, the engine speed gradually decreases to the low idle speed and the DPF Regen Ack lamp and EGT lamp turn off. Stationary regeneration is completed.



10. Press the 2nd left soft key to turn off the Interlock switch.

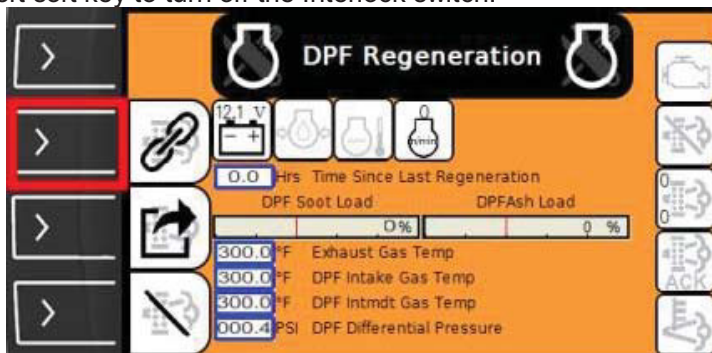

- a. The engine idle will return to the normal low idle of 1550RPM and the Auto-clutch will disengage.

SECTION 3 REPLACEMENT PARTS

3.1 Fuel/Water Tank Assembly, Super (2017- Present)

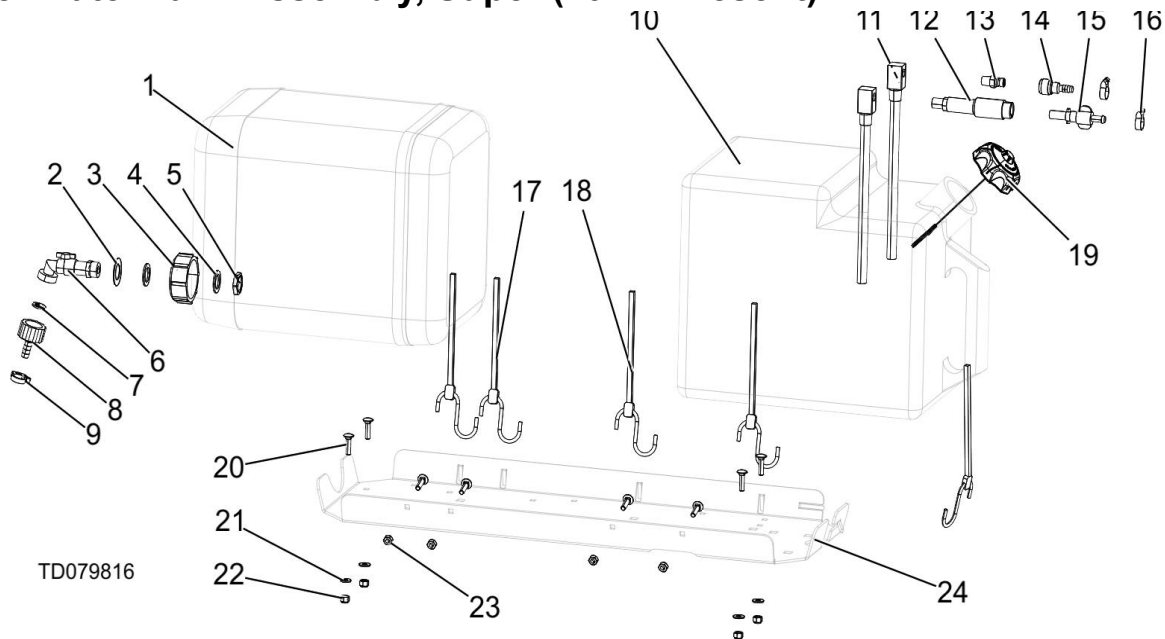

REF	PART #	DESCRIPTION	COMMENTS	QTY.
	079816	Assy, LT70 T4 Diesel Fuel Tray (US machines)	International machines 074488	1
	550787	Assembly, Water Bottle	Replaced 110731 per ECN 39257 in 1/24; which replaced 014637 per ECN35986 in 7/19	1
1	513866	Bottle, Water		1
2	550785	Cap. Water Bottle		1
3	550779	Gland Nut, 1/2 Npt		1
4	550780	O-ring, 27x20x1.5		2
5	530841	Shim, 21/37-1		1
6	550776	Fitting, Water Lube Shutoff Valve		1
7	550778	Gasket, 1/2 (Batard)		1
8	550777	Fitting, G3/4" X 10mm Hose Barb		1
9	016845	Clamp, Single Snap Grip, #38		1
10	P12166	Container, Refillable Fuel, Diesel		1
11	P12172	Fitting, 1/4NPTx9 Fuel Pick Up		2
12	P12175	Fitting, 1/4NPT Male-Female Discon		1
13	015583	Fitting, 1/4 NPT Male Quick Disconnect		1
14	015582	Fitting, Female Quick Disconnect Barb		1
15	P12176	Fitting, 1/4 Barb-male Discon		1
16	P649	Hose Clamp, 7/32in-5/8in		2
17	P11668	Strap, 20 Rubber W/hooks		2
18	P11258	Strap, 24 Rubber W/hooks		3
19	061257	Cap, Fuel Tank Diesel 080298ae		1
20	F05005-34	Bolt, 1/4-20 X 1 Carr		8
21	F05011-11	Washer, 1/4 SAE Flat		4
22	F05010-69	Nut, 1/4-20 Nylock		4
23	F05010-21	Nut, 1/4-20 Swaged		4
24	S11684	Plate, Gas Can/water Bottle		1
	010748	Clamp, Vinyl Coated Loom 1/2"x5/8"ID	Used on bottom of international	1

3.2 Fuel/Water Tank, Non-super

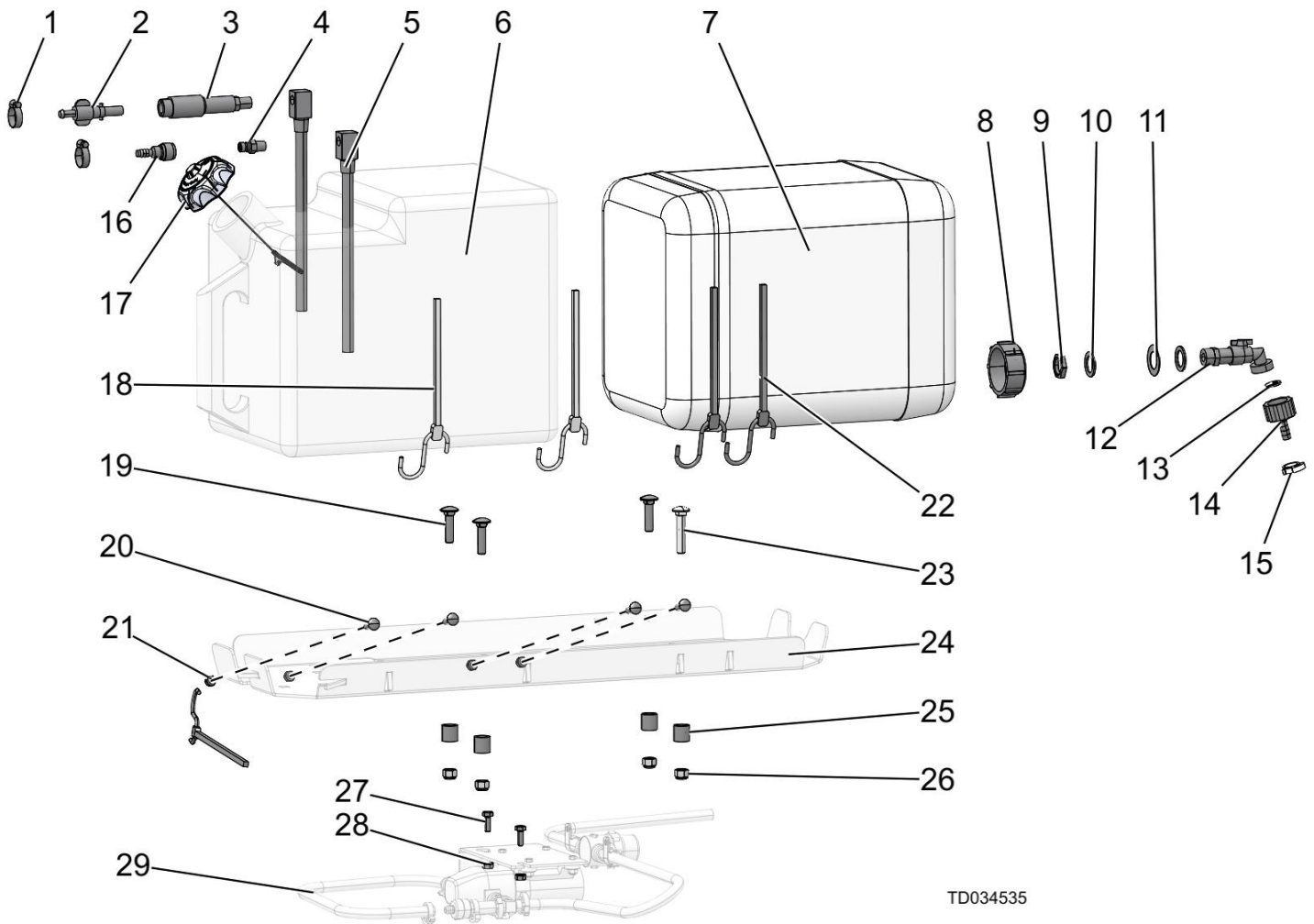

TD034535

REF	PART #	DESCRIPTION	COMMENTS	QTY.
	034535	Tray Assy, LT70 Diesel Fuel Can		1
1	P12739	Clamp, 11/16 Worm		2
2	P12176	Fitting, 1/4 Barb-Male Discon		1
3	P12175	Fitting, 1/4NPT Male-Female Discon		1
4	015583	Fitting, 1/4 NPT Male Quick Disconnect		1
5	P12172	Fitting, 1/4NPTx9 Fuel Pick Up		2
6	P12166	Container, Refillable Fuel, Diesel		1
	550787	Bottle Kit, 5 Gallon Water	Replaced 110731 per ECN 39290 on 1/2024	1
7	513866	Bottle, Water		1
8	550785	Cap. Water Bottle		1
9	550779	Gland Nut, 1/2 Npt		1
10	550780	O-ring, 27x20x1.5		2
11	530841	Shim, 21/37-1		1
12	550776	Fitting, Water Lube Shutoff Valve		1
13	550778	Gasket, 1/2 (Batard)		1
14	550777	Fitting, G3/4" X 10mm Hose Barb		1
15	016845	Clamp, Single Snap Grip, #38		1
16	015582	Fitting, Female Quick Disconnect Barb		1

REF	PART #	DESCRIPTION	COMMENTS	QTY.
17	061257	Cap, Fuel Tank Diesel 080298AE		1
18	P11258	Strap, 24 Rubber W/Hooks		2
19	F05007-85	Bolt, 3/8-16 X 1-1/2 CB		3
20	F05005-34	Bolt, 1/4-20 X 1 Carr		4
21	F05010-21	Nut, 1/4-20 Swaged		4
22	P11668	Strap, 20 Rubber W/Hooks		3
23	F05007-22	Bolt, 3/8-16x2 FT Carriage		1
24	S11684	Plate, Gas Can/Water Bottle		1
25	033911	Spacer, Pivot Lock Board Return		4
26	F05010-10	Nut, 3/8-16 Hex Nyl Lock		4
27	F05005-1	Bolt, 1/4-20x3/4 FT HHC		2
28	F05010-9	Nut, 1/4-20 Keps		2
29	033490	Pump/Filter Assembly, Lube-Mizer	See mill's Parts Manual for breakdown	1

3.3 Fuel/Water Tank, Non-super (2008-2017)

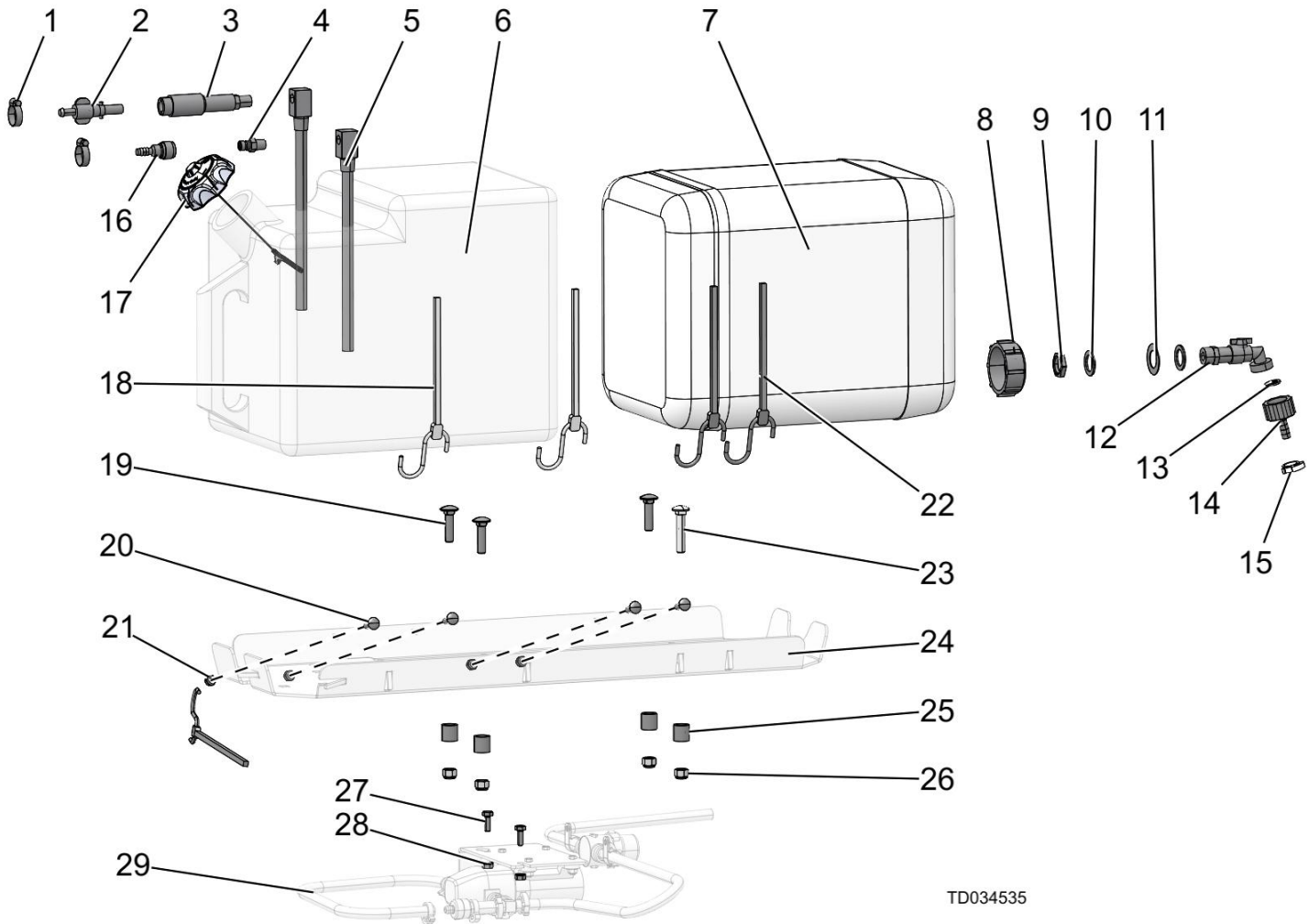

TD034535

REF	PART #	DESCRIPTION	COMMENTS	QTY.
	034535	Tray Assy, LT70 Diesel Fuel Can		1
1	P12739	Clamp, 11/16 Worm		2
2	P12176	Fitting, 1/4 Barb-Male Discon		1
3	P12175	Fitting, 1/4NPT Male-Female Discon		1
4	015583	Fitting, 1/4 NPT Male Quick Disconnect		1
5	P12172	Fitting, 1/4NPTx9 Fuel Pick Up		2
6	P12166	Container, Refillable Fuel, Diesel		1
	550787	Assembly, Water Bottle	Replaced 110731 per ECN 39257 in 1/2024; which replaced 014637 per ECN35986 in 7/2019	1
7	513866	Bottle, Water		1
8	550785	Cap. Water Bottle		1
9	550779	Gland Nut, 1/2 Npt		1
10	550780	O-ring, 27x20x1.5		2
11	530841	Shim, 21/37-1		1
12	550776	Fitting, Water Lube Shutoff Valve		1
13	550778	Gasket, 1/2 (Batard)		1
14	550777	Fitting, G3/4" X 10mm Hose Barb		1
15	016845	Clamp, Single Snap Grip, #38	Added after 2/12	1

REF	PART #	DESCRIPTION	COMMENTS	QTY.
16	015582	Fitting, Female Quick Disconnect Barb		1
17	061257	Cap, Fuel Tank Diesel 080298AE	Replaced P09683 per ECN 38938 in 4/2023	1
18	P11258	Strap, 24 Rubber W/Hooks		2
19	F05007-85	Bolt, 3/8-16 X 1-1/2 CB		3
20	F05005-34	Bolt, 1/4-20 X 1 Carr		4
21	F05010-21	Nut, 1/4-20 Swaged		4
22	P11668	Strap, 20 Rubber W/Hooks		3
23	F05007-22	Bolt, 3/8-16x2 FT Carriage		1
24	S11684	Plate, Gas Can/Water Bottle		1
25	033911	Spacer, Pivot Lock Board Return		4
26	F05010-10	Nut, 3/8-16 Hex Nyl Lock		4
27	F05005-1	Bolt, 1/4-20x3/4 FT HHC		2
28	F05010-9	Nut, 1/4-20 Keps		2
29	033490	Pump/Filter Assembly, Lube-Mizer	See mill's Parts Manual for breakdown	1

3.4 Engine Mount Assembly (2017-Present)

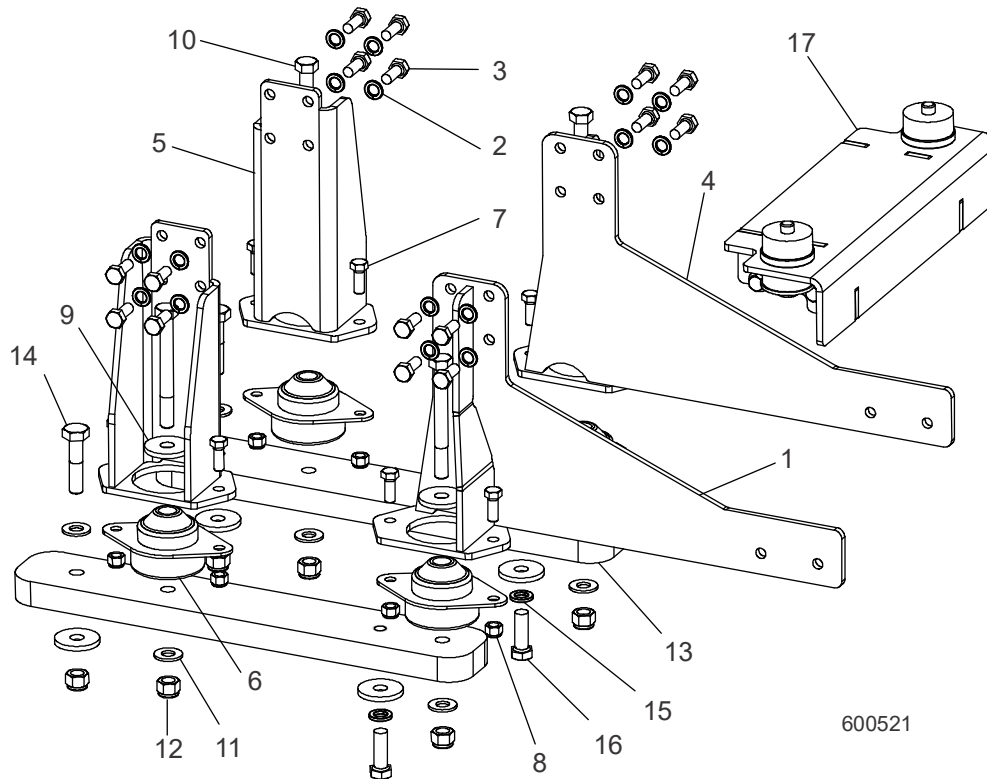

REF	PART #	DESCRIPTION	COMMENTS	QTY.
	079254	Mount Assembly, LT70 T4 Motor		1
1	006521	Weldment, Yanmar Left Engine Mount		1
2	F05011-88	Washer, 10MM Split Lock		16
3	F81003-11	Bolt, M10-1.5x25 Hex Head CI 8.8		16
4	006522	Weldment, Yanmar Right Engine Mount		1
5	079265	Weldment, LT70 T4 Rear Engine Mount		2
6	036095	Mount, Vibration Isolator		4
7	F05007-87	Bolt, 3/8-16x1 Gr5 Hex Head		8
8	F05010-10	Nut, 3/8-16 Hex Nyl Lock		8
9	014632	Washer, .52x1.69		8
10	F05008-35	Bolt, 1/2-13x4 1/2 GR5 Hex Head		4
11	F05011-2	Washer, 1/2 SAE Flat		6
12	F05010-8	Nut, 1/2-13 Nyl Hex Lock		6
13	079263	Plate, T4 Engine Mount Riser		2
14	F05008-10	Bolt, 1/2-13x2 1/4 Hex Head GR5		2
15	F05011-9	Washer, 1/2 Split Lock		2
16	F05008-33	Bolt, 1/2-13x1 1/2 Hex Head Gr5		2
17	074229	Assembly, Yanmar Lower Radiator Mount	(See Section 4.6)	1

3.5 Engine Mount Assembly (2008-2017)

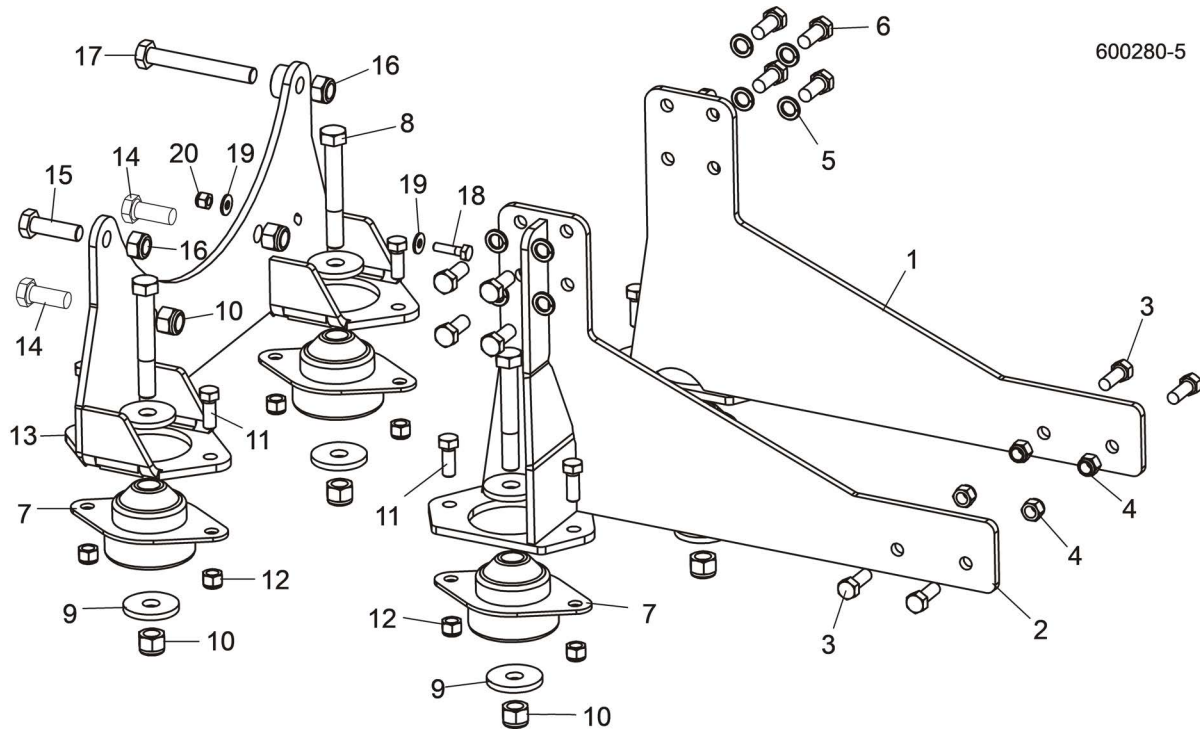

REF	PART #	DESCRIPTION	COMMENTS	QTY.
	074258	Assembly, Yanmar 55HP Motor Mount		1
1	006522	Mount Weldment, Yanmar Right		1
2	006521	Mount Weldment, Yanmar Left		1
3	F05007-7	Bolt, 3/8-16 x 1" Hex Head		4
4	F05010-10	Nut, 3/8-16 Hex Nylon Lock		4
5	F81003-11	Bolt, M10-1.5 x 25mm Hex Head Grade 8.8		8
6	F05011-88	Washer, 10mm SPlit Lock		8
7	036095	Mount, Vibration Isolator		4
8	F05008-61	Bolt, 1/2-13" x 3 1/2" HeX Head Grade 5		4
9	014632	Washer, .52 x 1.69		8
10	F05010-8	Nut, 1/2-13 Nylon Hex Lock		6
11	F05007-87	Bolt, 3/8-16 x 1" Hex Head Grade 5		8
12	F05010-10	Nut, 3/8-16 Hex Nylon Lock		8
13	006535	Mount Weldment, Yanmar rear		1
14	F05008-37	Bolt, 1/2-13 x 1 1/4" Hex Head Grade 5		2
15	F05004-250	Bolt, M12 x 1.75 X 40mm Hex Head Full Thread		1
16	F05010-209	Nut, M12 x 1.75 Hex Nylon Lock		2
17	F05004-249	Bolt, M12 X 1.75 X 90mm Hex Head Full Thread		1
18	F05005-101	Bolt, 1/4-20 X 1" Hex Head Grade 5		1
19	F05011-11	Washer, 1/4" SAE Flat		2
20	F05010-69	Nut, 1/4-20 Nylon Lock		1

3.6 Engine Assembly T4 (Super 2017-Present)

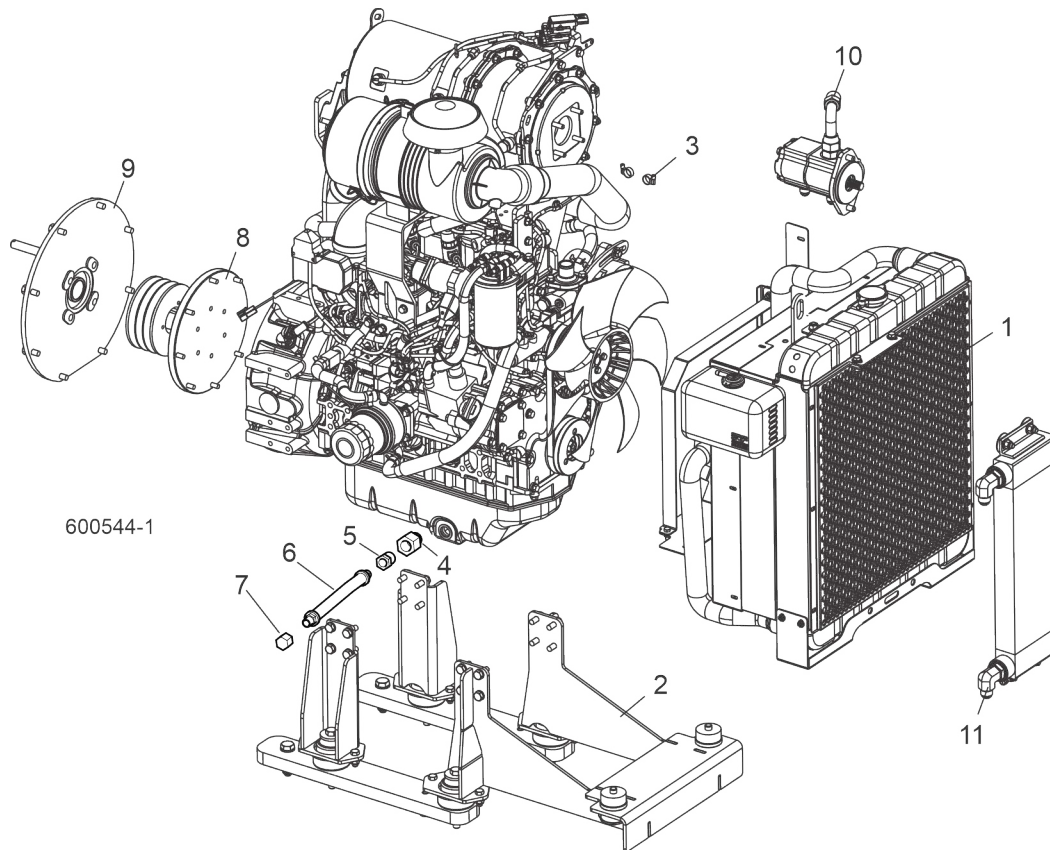

REF	PART #	DESCRIPTION	COMMENTS	QTY.
	CED47	Cover, D55 Engine		1
	110141	Engine, Yanmar 55HP Tier 4 Diesel Super 70	Used with LT70HDD55-RH and LT70HDD55W-RH only	1
1	N/A	D55 Tier 4 Engine Radiator Parts	(See Section 4.15)	1
2	079254	Assembly, LT70 T4 Motor Mount	(See Section 4.12)	1
3	P649	Hose Clamp, 7/32"-5/8"		2
	074263	Drain Assembly, Yanmar 55HP Oil		1
	006640	Fitting, M22 x 1/2" NPT		1
	028073	Fitting, 1/2" NPT x 3/8" NPT Hex Reducer		1
	046026	Fitting, 3/8" NPT Street Elbow		1
6	P10082	Hose, 3/8" NPT x 9 5/8" Rubber		1
7	P04332	Fitting, 3/8" Galvanized Pipe Cap		1
8	074514	Assembly, LT70 Hyd 55HP Stub Shaft	See Section 4.4	1
9	079262	Assembly, T4 Final Bearing Support	See Section 4.8	1
10	079253	Assembly, T4 Dual Hydraulic Oil Pump	See Sawmill Parts Manual	1
11	074531	Assembly, Hydraulic Oil Cooler	See Sawmill Parts Manual	1
	061403	Belt, Fan 129044-42290		1
	061404	Filter, Oil 129150-35153		1
	057938	Thermostat, Yanmar TNV		1
	044652	Gasket, Thermostat Cover 129795-49551		1

REF	PART #	DESCRIPTION	COMMENTS	QTY.
	061245	Switch, Oil Pressure Tier 3 LT70 Super		1
	061405	Filter, Fuel 129C00-55800		1
	061310	Filter, Water Separator 129A00-55730		1
	078705	Pump, Yanmar Fuel Feed		1
	078719	Relay, Yanmar EGR Valve		1
	057945	Glow Plug, Starter Aid, Yanmar TNV88		4
	061323	Filter, Air Tier 4 129687-12510		1
	141020	A/C Assembly, KAC23		1

3.7 Engine Assembly T2, T3 (2008 - 2017)

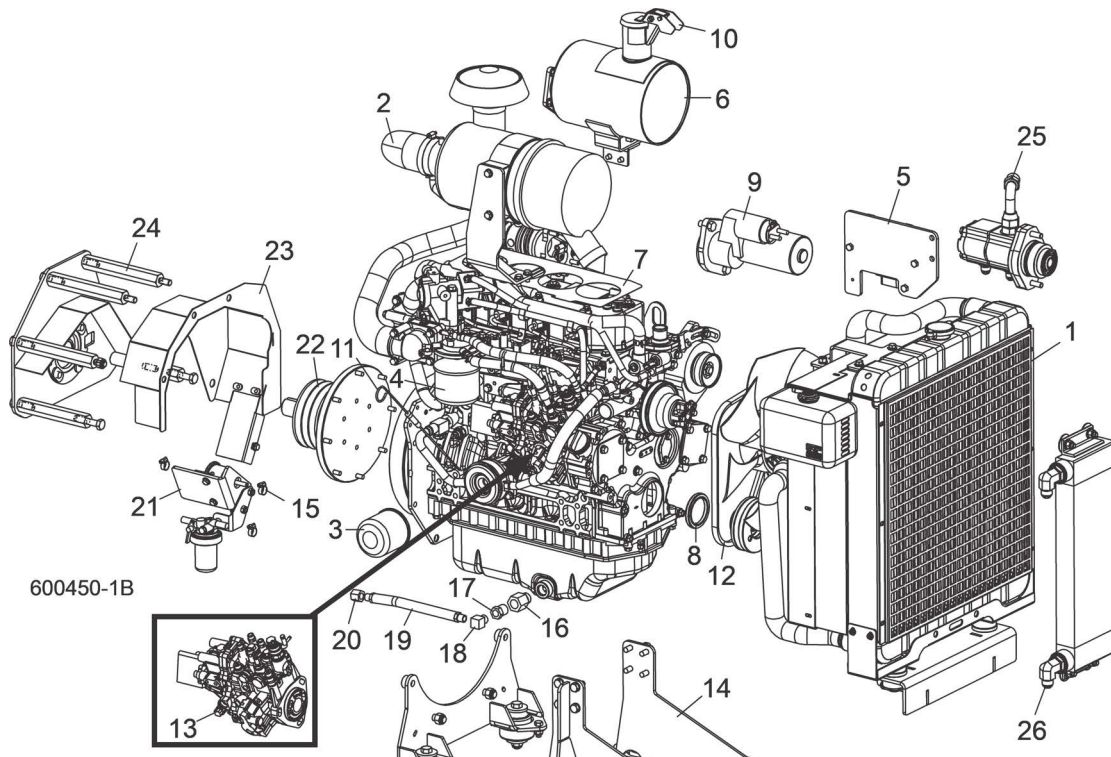

REF	PART #	DESCRIPTION	COMMENTS	QTY.
	CED47	Cover, D55 Engine		1
	006493	Engine, Yanmar 55HP Tier 3 Diesel	No longer available for US sale	1
1		Radiator Parts	(See Section 4.14)	
2	006515	Air Cleaner Assembly, Yanmar #KAC-6		1
	061744	Air Filter, Yanmar #129687-12510		1
	061100	Cap, Air Filter Assembly Yanmar		1
3	057935	Filter, Oil #129150-35153		1
4	057933	Filter, Fuel #119802-55801		1
5		Electronic Control Unit Parts	(See Section 4.11)	
6	006516	Muffler Assembly, Yanmar #KM-5		1
	061145	Cap, Muffler Rain D55 Yanmar		1
7	061753	Gasket, Yanmar Bonnet #129508-11310		1
8	061751	Seal, Yanmar Front Main #129795-01800		1
	061750	Injector Assembly, Yanmar #729649-53100		1
	061245	Switch, Yanmar Oil Pressure #119761-39450	All Tier 3 Engines LT70Super	1
	065165	Switch, Yanmar Oil Pressure	DCS Only	1
9	061749	Starter Motor, Yanmar #129400-77012		1
	057938	Thermostat, Yanmar #129155-49801		1
	044641	Alternator, Yanmar 3TVN70-ASA #129423-77200		1
	069557	Relay, Yanmar D55T3 Main/rack Actuator		1
	044652	Gasket, Yanmar Thermostat #129795-49551		1
	057939	Pump, Yanmar Water #129001-42001		1
	057940	Gasket, Yanmar Water Pump #129486-42021		1

REF	PART #	DESCRIPTION	COMMENTS	QTY.
	061172	Sender, Yanmar Water Temperature #129927-44900		1
	044657	Diode, Yanmar Solenoid Relay #119643-66900		1
	057941	Timer, Yanmar Air Heater #128300-77920		1
	061747	Gasket, Yanmar Head #129508-01330		1
	057943	Plug, Yanmar Oil Drain #119640-01640		1
	057944	Seal, Yanmar Oil Drain #22190-220002		1
	061053	Spring, Governor Yanmar #129573-61700		1
	061142	Relay, Start Yanmar		1
10	061073	Cap, Yanmar Rain #129087-13530		1
	061113	Heater Kit, Engine Block Yanmar Includes Parts #061078 and #061079		1
	061078	Heater, Engine Yanmar D55 #171015-77900		1
	061079	Cable, Engine Heater Yanmar D55 #3600003		1
11	057946	Dip Stick, Yanmar Oil #129004-34802		1
12	061745	Belt, Yanmar Fan #119831-42290		1
	057947	Pipe, Yanmar Fuel Return #129004-49610		1
	061181	Heater, Engine Glow #129100-77501		1
	061182	Gasket, Heater Manifold Side #129100-77510		1
	061183	Gasket, Heater Intake Side #129150-77511		1
13	061291	Pump Assembly. Inj. D55 #729509-51300		1
14		Engine Mount Parts	(See Section 3.4)	
15	P649	Hose Clamp, 7/32"-5/8"		4
	074263	Drain Assembly, Yanmar 55HP Oil		1
16	006640	Fitting, M22 x 1/2" NPT		1
17	028073	Fitting, 1/2" NPT x 3/8" NPT Hex Reducer		1
18	046026	Fitting, 3/8" NPT Street Elbow		1
19	P10082	Hose, 3/8" NPT x 9 5/8" Rubber		1
20	P04332	Fitting, 3/8" Galvanized Pipe Cap		1
21		Yanmar 55HP Fuel Pump Parts	(See Section 3.8)	
22		Drive Hub Parts	See Section 4.9	
23		Flywheel Parts	(See Section 3.22)	
24		Bearing Support Parts	(See Section 4.22)	
25		Dual Hydraulic Oil Pump Parts	See Sawmill Parts Manual	
26		Hydraulic Oil Cooler Parts	See Sawmill Parts Manual	

3.8 Fuel Pump Assembly

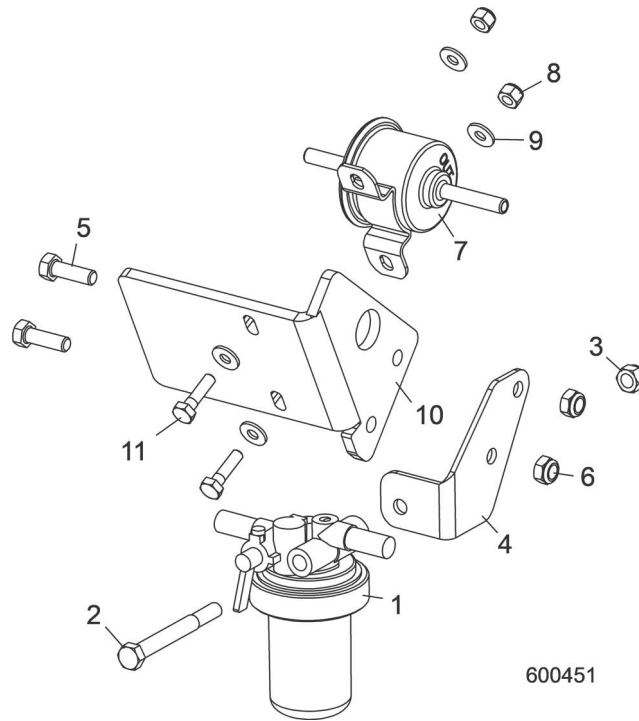

REF	PART #	DESCRIPTION	COMMENTS	QTY.
	074262	Assy, Yanmar 55HP Fuel Pump		1
1	061300	Filter Assembly, Water Separator D55 #129242-55701		1
	061301	Filter, Water Separator D55 #129242-55730		1
2	F05006-62	Bolt, 5/16-18 x 3" Hex Head Grade 5		1
3	F05010-58	Nut, 5/16-18 Hex Nylon Lock		1
4	006801	Bracket, Fuel Filter Mount		1
5	F05004-40	Bolt, M8-1.25 x 1" Hex Head Grade 8.8		2
6	F05010-132	Nut, M8-1.25 Hex Nylon Lock		2
7	061074	Pump, Yanmar Fuel Feed		1
8	F05010-69	Nut, 1/4-20 Nylock		2
9	F05011-11	Washer, 1/4" SAE Flat		4
10	006566	Plate, Yanmar Throttle Solenoid Mount		1
11	F05005-101	Bolt, 1/4-20 X 1" Hex Head Grade 5		2

3.9 Drive Assembly (Tier 3)

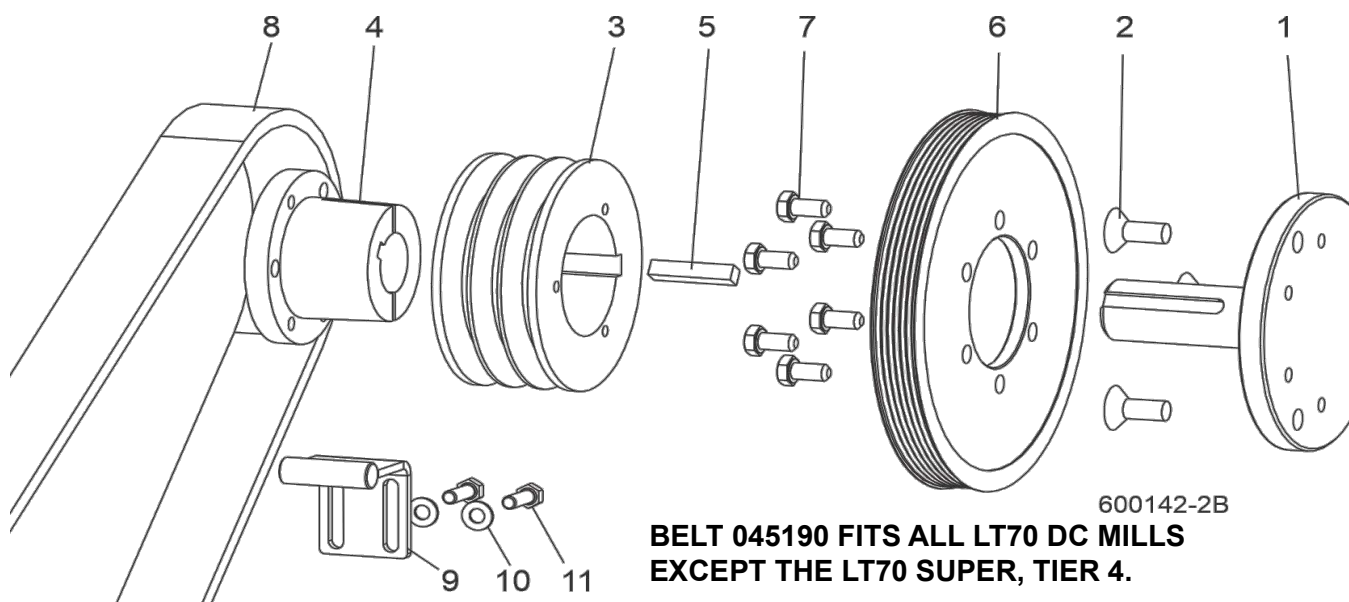

REF	PART #	DESCRIPTION	COMMENTS	QTY.
	074264	Assy, Yanmar 55HP Stub Shaft		1
1	045633	Shaft, Caterpillar Drive		1
2	F05007-194	Bolt, M12 X 1.75 X 30mm Socket Flat Head		3
3	006320	Sheave, 3q5v55 Drive		1
4	038174	Bushing, 1 7/16 SDS		1
5	014693	Key, 3/8" X 3/8" X 1 7/8"		1
6	033878	Pulley, 9" Od Poly-v		1
7	F05004-207	Bolt, M10 -1.5 X 20mm Hex Head Full Thread Grade 8.8		6
8	045190	Belt, 3/5VFX950 Drive		1
9	034590	Bracket Weldment, Belt Support		1
10	F05011-17	Washer, 5/16" SAE Flat		2
11	F05006-48	Bolt, 5/16-18 x 1" Hex Head Grade 5		2

3.10 Drive Assembly (Tier 4)

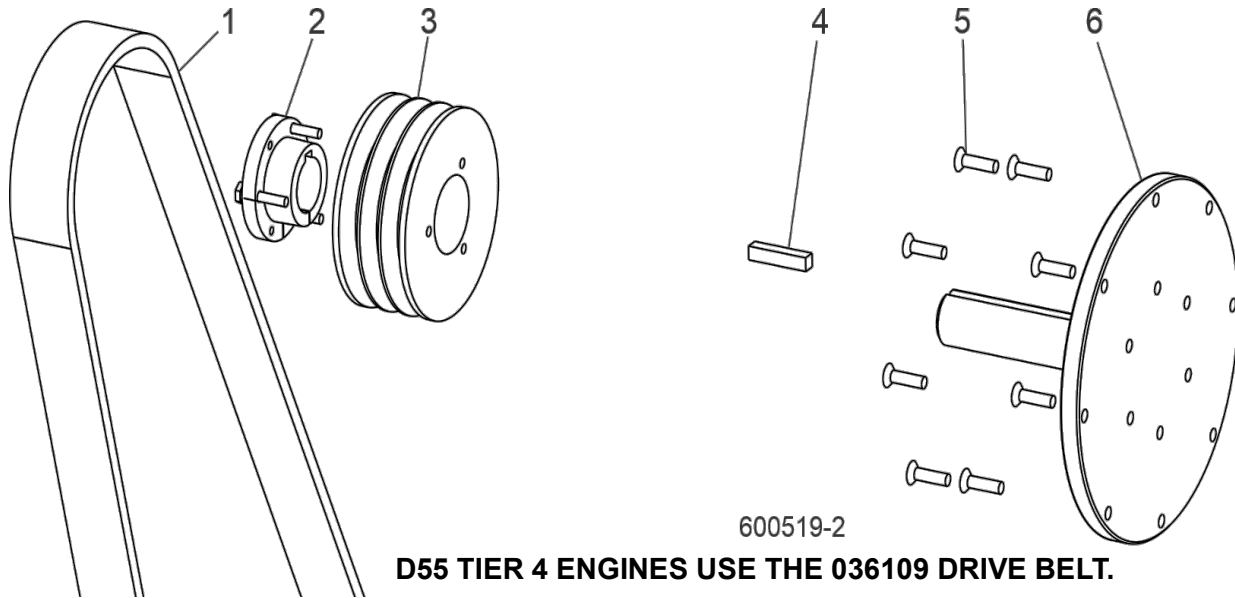

REF	PART #	DESCRIPTION	COMMENTS	QTY.
1	036109	Belt, 3/5VXFL975 Drive		1
	074514	Assy, LT70 Hyd 55HP Stub Shaft		1
2	038174	Bushing, 1 7/16 SDS		1
3	006320	Sheave, 3/5v5.5 SDS		1
4	014693	Key, 3/8x3/8x1 7/8		1
5	F05004-245	Screw, M8x1.25x30mm Flat Socket C/S BO		8
6	071326	Shaft, Yanmar Large Stub		1

3.11 Electronic Control Unit (ECU - All Except Tier 4)

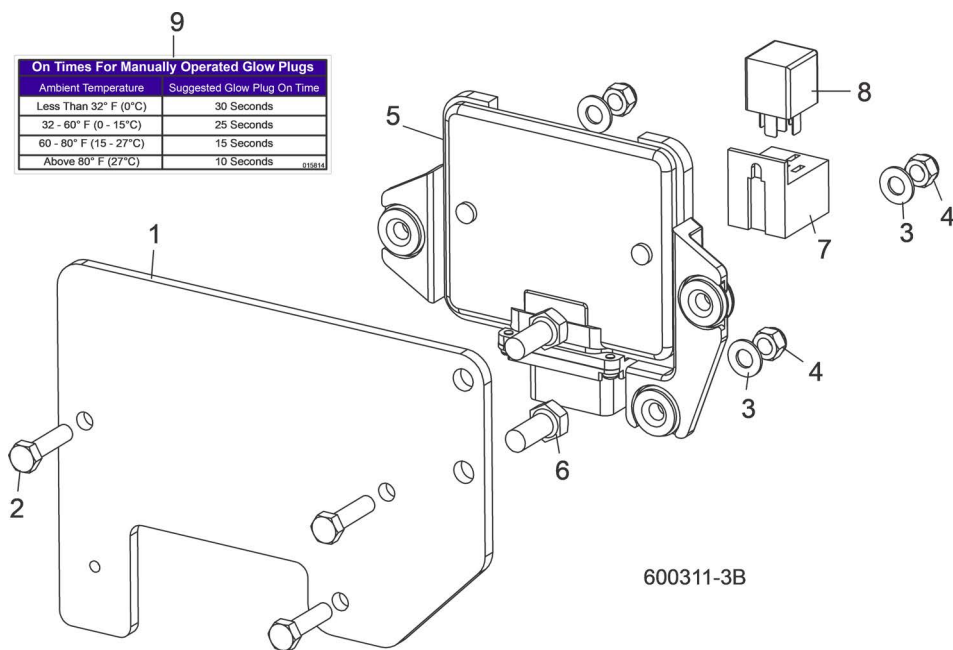

REF	PART #	DESCRIPTION	COMMENTS	QTY.
	074259	ECU Assembly, Yanmar 55HP		1
1	007819	Plate, ECU Mount		1
2	F05006-93	Bolt, 5/16-18 x 1 1/4" Hex Head Full Thread Grade 5		3
3	F05011-17	Washer, 5/16" SAE Flat		3
4	F05010-58	Nut, 5/16-18 Hex Nylon Lock		3
5	N/A	Control Assembly, D55 Electronic	Available in assemblies only. ECU must be matched to fuel delivery system. Contact Yanmar for replacement information.	1
6	F81003-11	Bolt, M10-1.5 x 25mm Hex Head Grade 8.8		2
	069376	Relay Assembly, D55 Tier 3 Throttle		1
7	069527	Socket Assembly, D55T3 Throttle Relay	Socket Assembly 069527 replaces socket 050033 for service replacement (2/11).	1
8	051335	Relay, ISO 12V Coil w/Diode		1
9	015814	Decal, Glow Plug Operation		1

3.12 Throttle & Relay Assembly (11/2008 - 8/2017)

LT70HDs rev. B2.00 - rev. B6.13
LT70 Supers rev. A1.00 - rev. A5.04

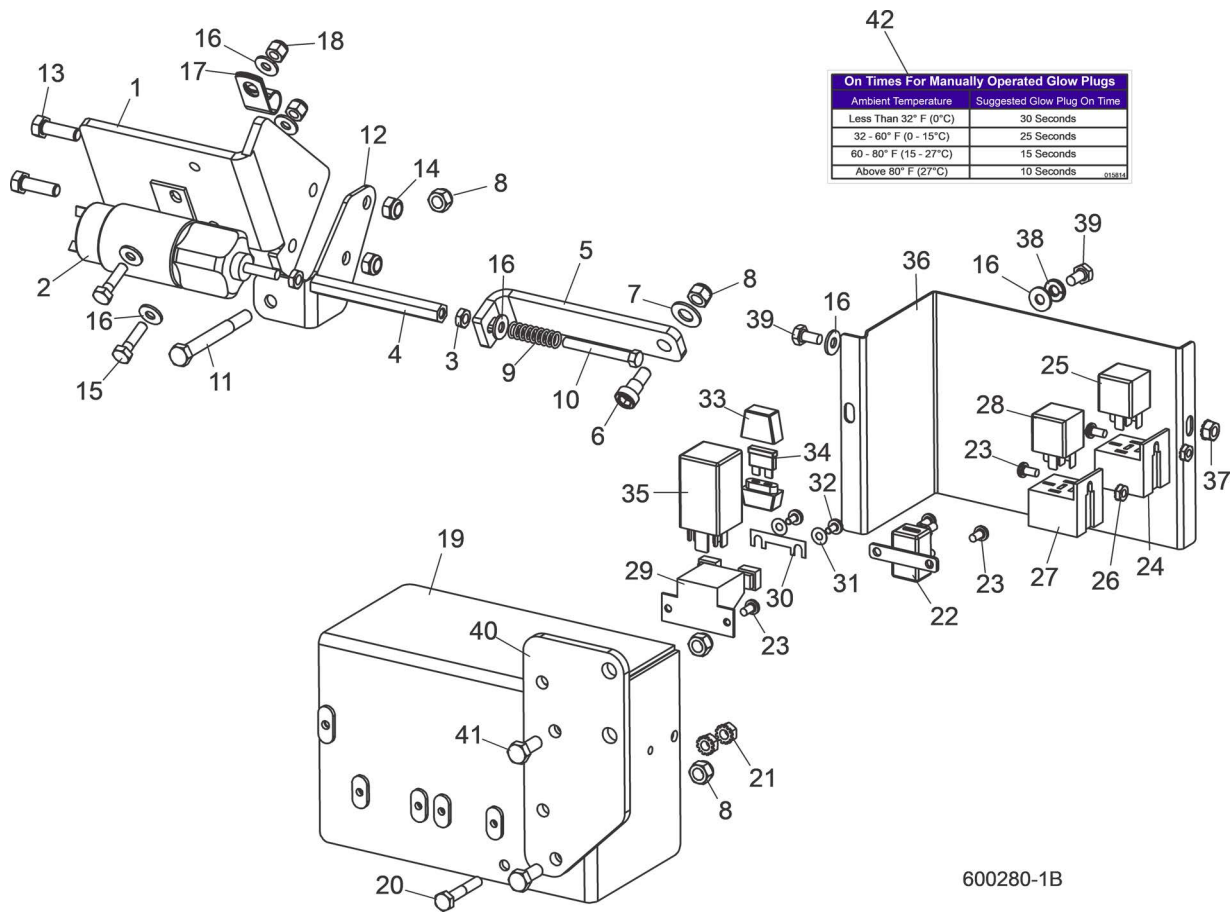

REF	PART #	DESCRIPTION	COMMENTS	QTY.
1	006566	Plate, Yanmar Throttle Solenoid Mount		1
	074475	Solenoid Kit, Throttle, Yanmar/Cat		1
2	045848	Solenoid, Throttle		1
	074475-2058	Instruction Sheet, Solenoid Adjustment		1
3	F05010-113	Nut, 1/4-28 Hex Jam		2
4	045850	Link, Throttle Actuator		1
5	006568	Plate, Long Throttle Connecting		1
6	F05007-159	Bolt, 3/8" X 5/16-18" sOCKET HEAD sHOULDER		1
7	F05011-3	Washer, 3/8" SAE Flat		1
8	F05010-58	Nut, 5/16-18 Hex Nylon Lock		4
9	P11644	Spring, .42" x 1.34" x .061"		1
10	F05005-188	Bolt, 1/4-28 x 2" Hex Head Grade 5		1
11	F05006-62	BOlt, 5/16-18 x 3" Hex Head Grade 5		1
12	006801	Bracket, Fuel/Water Separator Mount		1
13	F05004-40	Bolt, M8-1.25 x 1mm Hex Head		2
14	F05010-132	Nut, M8 Hex Nylon Lock		2
15	F05005-101	Bolt, 1/4-20 x 1" Hex Head Grade 5		2

REF	PART #	DESCRIPTION	COMMENTS	QTY.
16	F05011-11	Washer, 1/4" SAE Flat		7
17	P07584	Clamp, 1/2" EMT Coated		1
18	F05010-69	Nut, 1/4-20 Hex Nylon Lock		2
	053235	Bracket Assembly, Yanmar Relay		1
19	036269	Bracket Weldment, Glow Plug Relay Mount		1
20	F05005-31	Bolt, 1/4-20 x 1 1/2" Hex Head Full Thread		1
21	F05010-9	Nut, 1/4-20 Self-Locking Hex		2
22	E20430	Breaker, 15A Manual Reset Circuit		1
23	F05004-3	Screw, #10-24 x 3/8" Phillips Head		6
	053234	Relay Assembly, Yanmar Throttle (2008)		1
24	050033	Socket, Relay Plug		1
25	051335	Relay, ISO 12V Coil w/Diode		1
26	F05010-14	Nut, #10-24 Hex		2
	053233	Relay Assembly, Yanmar Starter (2008)		1
27	050033	Socket, Relay Plug		1
28	051335	Relay, ISO 12V Coil w/Diode		1
	053232	Relay Assembly, Yanmar Glow Plug (2008)		1
	053388	Socket Kit, Yanmar Glow Plug Relay Replacement		1
29	024554	Socket, Glow Plug Relay w/Fuse Holder		1
30	024597	Fuse Link, 50 Amp		1
31	F81052-4	Washer, M5 Wave		2
32	F81000-14	Screw, M5-0.8 x 8mm Phillips Head Black Oxide		2
33	024555	Fuseholder, In-Line 3-20A ATC w/Cover		1
34	024150-4	Fuse, 4A ATO Blade (Pink)		1
	052663	Resistor Kit, Glow Plug		1
35	023359	Relay, Diesel Glow Plug		1
36	045824	Cover, Relay Assembly		1
37	F05010-9	Nut, 1/4-20 Self-Locking Hex		1
38	F05011-14	Washer, 1/4" Split Lock		1
39	F05005-15	Bolt, 1/4-20 X 1/2" Hex Head		2
40	006523	Plate, Glow Plug Relay Mount Adaptor		1
41	F05006-5	Bolt, 5/16-18 x 3/4" Hex Head		2
42	015814	Decal, Glow Plug Operation		1

3.13 ECU Assembly (Tier 4)

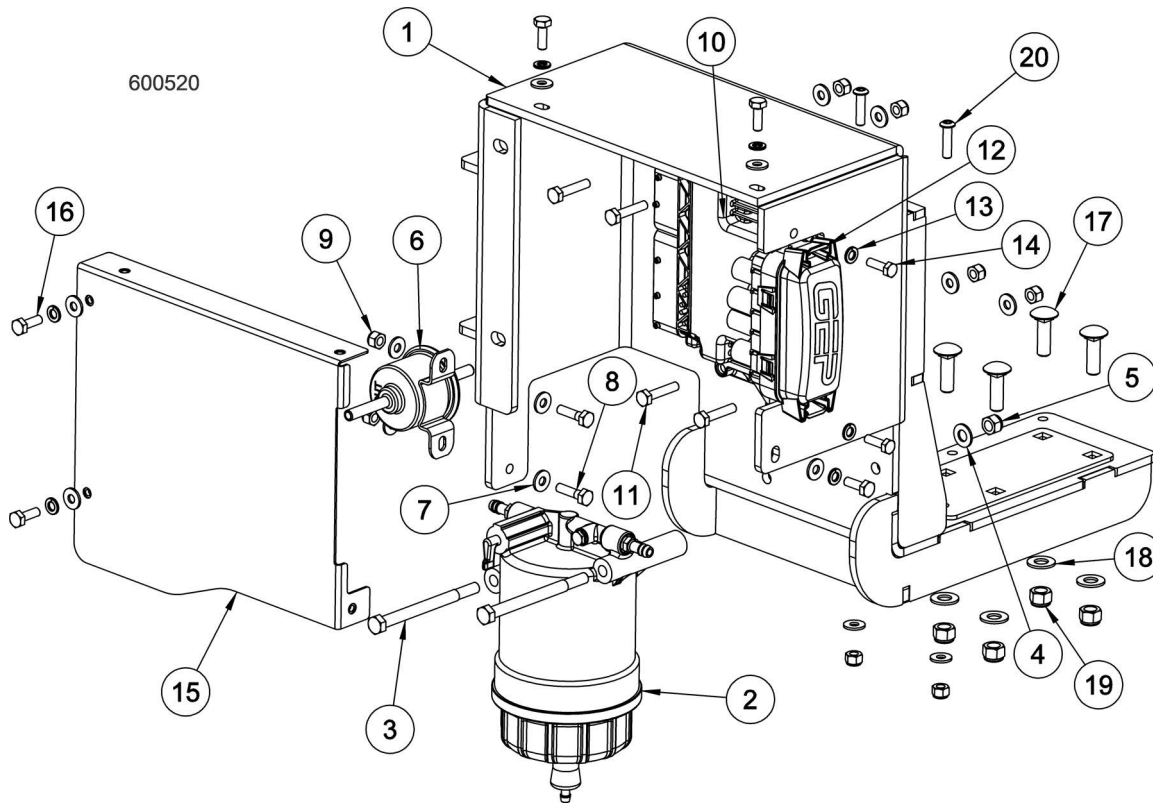

REF	PART #	DESCRIPTION	COMMENTS	QTY.
	079334	ECU ASSEMBLY, LT70D46 T4		1
1	079463	Weldment, LT70D46 T4 ECU Mnt		1
2	061309	Assembly, Water Separator 129A00-55700		1
	061310	Filter, Water Separator 129A00-55730		1
3	F05006-109	Bolt, 5/16-18x4 Hex Head Gr5		2
4	F05011-17	Washer, 5/16 SAE Flat		2
5	F05010-58	Nut, 5/16-18 Nyl Lock		2
6	078705	Pump, Yanmar Fuel Feed		1
7	F05011-11	Washer, 1/4 SAE Flat		15
8	F05005-101	BOLT, 1/4-20 X 1 HEX HEAD GR5		2
9	F05010-69	Nut, 1/4-20 Nylock		8
10	N/A	Yanmar T4 Final ECU (Supplied w/Engine)	When replacing the ECU, it is necessary to update the software of the ECU using the designated service tool. Please contact Yanmar for details.	1
11	F05005-116	Bolt, 1/4-20x1 1/4 Hex Head Gr5		4
12	N/A	Assembly, D46 T4 Fuse/Relay (Supplied w/Engine)		1
	061315	Relay, Start/Glow Plug 30M9206		2
	061316	Fuse, Max 60 299060		1
	061317	Fuse, Max 80 299080		1
13	F05011-14	Washer, 1/4 Split Lock		7
14	F05020-6	Bolt, M6-1x20 Hex Head Class 8		2
15	079455	Weldment, LT70D46 T4 ECU Cover		1

3 Replacement Parts

ECU Assembly (Tier 4)

REF	PART #	DESCRIPTION	COMMENTS	QTY.
16	F05005-123	Bolt, 1/4-20x3/4 Hex Head Gr5		5
17	F05007-127	Bolt, 3/8-16x1 1/4 Carriage Gr5		4
18	F05011-3	Washer, 3/8 Flat SAE		4
19	F05010-10	Nut, 3/8-16 Hex Nyl Lock		4
20	F05005-200	Bolt, 1/4-20x1 SBHC BO		2

3.14 Radiator Assembly (Tier 3)

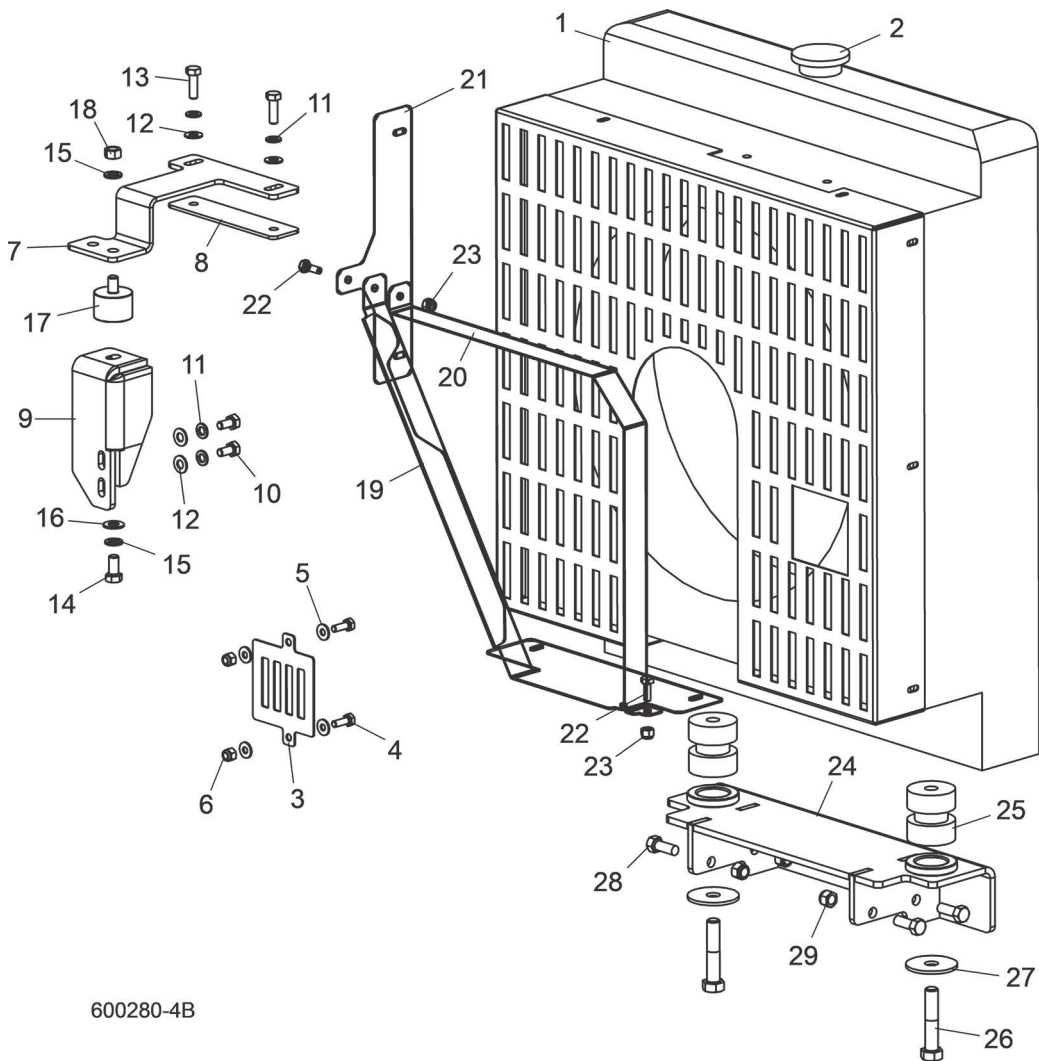

600280-4B

REF	PART #	DESCRIPTION	COMMENTS	QTY.
1	006517	Radiator, Diesel Engines #KR16		1
2	044660	Cap, Yanmar Radiator #129987-44570		1
	061087	Coolant Overflow, Yanmar #129689-44000		1
	074231	Cover ASsembly, KR9 Radiator Cutout		1
3	006769	Plate, KR9 Radiator Cutout Cover		1
4	F05005-1	Bolt, 1/4-20 x 3/4" Full Thread Hex Head Cap		2
5	F05011-11	Washer, 1/4" SAE Flat		4
6	F05010-69	Nut, 1/4-20 Nylon Lock		2
	074227	Mount Assembly, Yanmar Upper Radiator		1
7	006713	Plate, Yanmar Top Radiator support		1
8	006557	Plate, Top Radiator MOUNT Spacer		1
9	006558	Plate, Yanmar Top Radiator MOUNT		1
10	F05004-47	Bolt, M8 x 125 x 16mm Hex Head		2
11	F05011-45	Washer, 8mm Split Lock		4
12	F05011-17	Washer, 5/16" SAE Flat		4
13	F05004-40	Bolt, M8 x 1.25 x 1 Hex Head Full Thread		2
14	F05007-27	Bolt, 3/8-16 x 3/4" Hex Head Grade 2		1

REF	PART #	DESCRIPTION	COMMENTS	QTY.
15	F05011-4	Washer, 3/8" SPlit Lock		2
16	F05011-3	Washer, 3/8" SAE Flat		1
17	028217	Bushing, Rubber Radiator Mount		1
18	F05010-1	Nut, 3/8-16 Hex		1
19	006730	Plate, Radiator Lower Cover		1
20	006731	Plate, Radiator guard wrap		1
21	006732	Plate, Radiator Side Guard		1
22	F05005-1	Bolt, 1/4-20 x 3/4" hex head Full thread		2
23	F05010-69	Nut, 1/4-20 Hex Nylon Lock		2
	074229	Mount Assembly, Yanmar Lower Radiator		1
24	006530	Mount Weldment, Yanmar Radiator		1
25	018734	Bushing, Rubber Mount		2
26	F05008-74	Bolt, 1/2-13 x 2 1/2" Hex Head Grade 5		2
27	018751	Washer, Engine Mount		2
28	F05007-7	Bolt, 3/8-16 x 1" Hex Head Cap		4
29	F05010-10	Nut, 3/8-16 Hex Nylon Lock		4

3.15 Radiator Assembly (Tier 4)

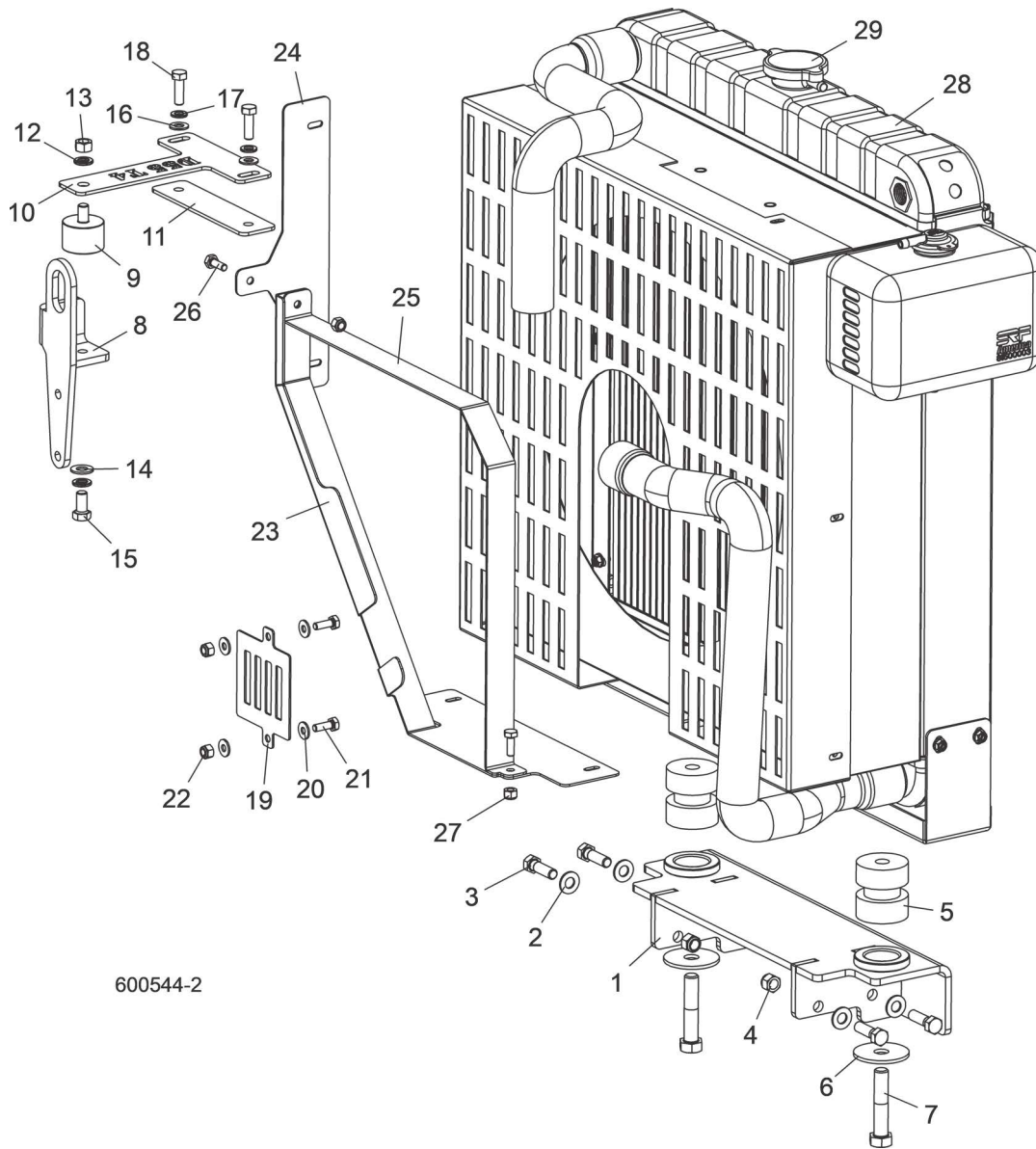

600544-2

REF	PART #	DESCRIPTION	COMMENTS	QTY.
	074229	Assembly, Yanmar Lower Radiator Mount		1
1	006530	Weldment, Yanmar Radiator Mount		1
2	F05011-3	Washer, 3/8 Flat SAE		4
3	F05007-123	Bolt, 3/8-16x 1 1/4 Hex Head Gr5		4
4	F05010-10	Nut, 3/8-16 Hex Nyl Lock		4
5	018734	Bushing, Rubber Mount		2
6	018751	Washer, Motor Mount		2
7	F05008-144	Bolt, Hex Head 1/2-13x2 3/4 Gr5 Zinc	F05008-144 replaced F05008-74 per ECN 38392 on 2/22/22.	2
	110572	Assembly, D55 Tier 4 Yanmar Upper Radiator Mount		1
8	110570	Plate, D55 T4 Top Radiator Mount		1
9	028217	Bushing, Rubber Radiator Mount		1
10	110571	Plate, D55 T4 Upper Radiator Brace		1

REF	PART #	DESCRIPTION	COMMENTS	QTY.
11	006557	Plate, Top Radiator Mount Spacer		1
12	F05011-4	Washer, 3/8 Split Lock		2
13	F05010-1	Nut, 3/8-16 Hex		1
14	F05011-3	Washer, 3/8 Flat SAE		1
15	F05007-27	Bolt, 3/8-16x3/4 Hex Head Gr2		1
16	F05011-17	Washer, 5/16 SAE Flat		2
17	F05011-45	Washer, 8mm Split Lock, Zn		2
18	F05004-40	Bolt, M8x1.25x25 Hex Head FT		2
	074231	Assembly, KR9 Radiator Cutout Cover		1
19	006769	Plate, KR9 Radiator Cutout Cover		1
20	F05011-11	Washer, 1/4 SAE Flat		4
21	F05005-1	Bolt, 1/4-20x3/4 FT Hex HeadC		2
22	F05010-69	Nut, 1/4-20 Nylock		2
23	079275	Plate, T4 Radiator Lower Cover		1
24	006732	Plate, KR9 Radiator Side Guard		1
25	006731	Plate, KR9 Radiator Guard Wrap		1
26	F05005-1	Bolt, 1/4-20x3/4 FT Hex HeadC		2
27	F05010-69	Nut, 1/4-20 Nylock		2
28	006517	Radiator, Diesel Engines #KR16		1
29	044660	Cap, Yanmar Radiator #129987-44570		1
	061087	Coolant Overflow, Yanmar #129689-44000		1

3.16 Alternator Assembly (2/2010-1/2015)

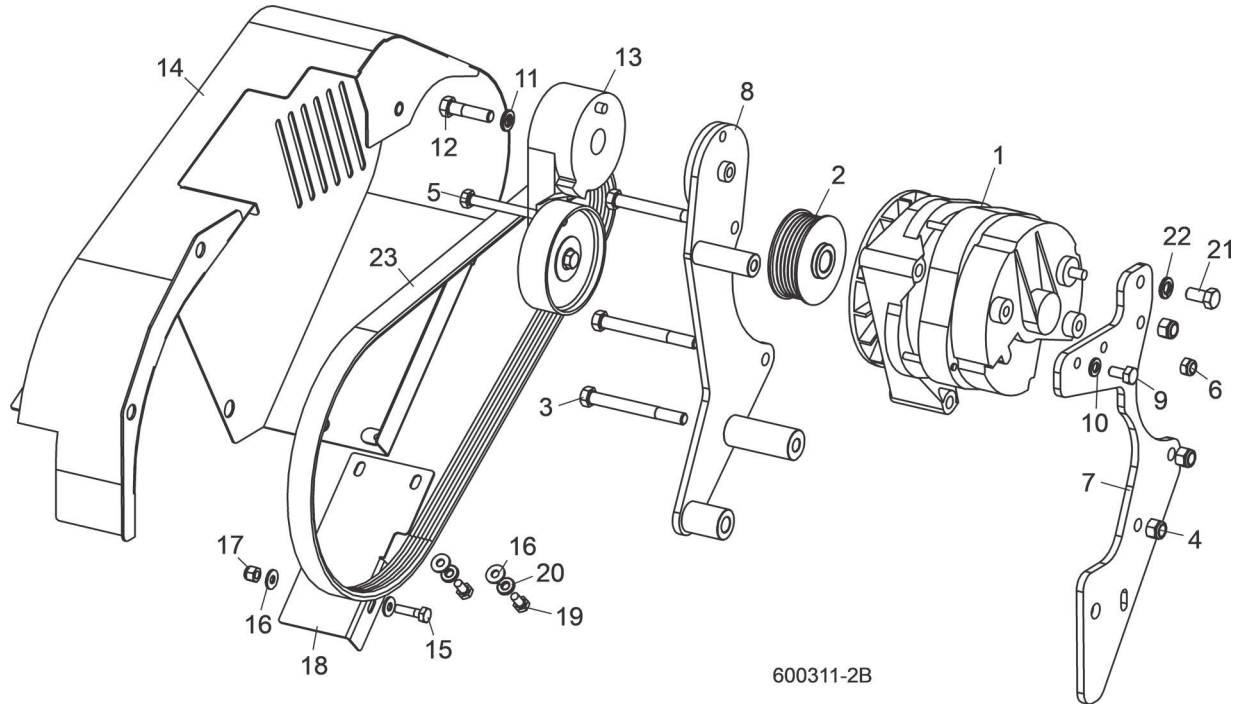

600311-2B

REF	PART #	DESCRIPTION	COMMENTS	QTY.
	052048	Wire Assembly, Starter To Alternator 21"		1
	074260	Alternator Assembly, Yanmar 55HP Tier3		1
	034500	Alternator Assembly, 190 Amp		1
1	034499	Alternator, 190 Amp	Available in assemblies only.	1
2	046402	Pulley, 2 3/4" O.D. Alternator		1
3	F05004-123	Bolt, 3/8-16 x 3 1/2" Hex Head Grade 5		3
4	F05010-10	Nut, 3/8-16 Hex Nylon Lock		3
5	F05004-247	Bolt, M8 x 1.25 x 90mm Hex Head Full thread		1
6	F05010-132	Nut, M8 Hex Nylon Lock		1
7	013980	Bracket Weldment, Yanmar Alternator Mount		1
8	057493	Bracket Weldment, Yanmar Alternator Tensioner Mount		1
9	F05004-47	Bolt, M8 x 125 x 16mm Hex Head		1
10	F05011-45	Washer, 8mm Split Lock		1
11	F05011-4	Washer, 3/8" Split Lock		1
12	F05007-78	Bolt, 3/8-16 x 1 1/2" Hex Head Grade 5		1
13	034464	Tensioner, Alternator Belt		1
	074261	Cover Assembly, Yanmar 55HP Alternator Tier3		1
14	006880	Guard Weldment, Yanmar 55HP Tier 3 Alternator Belt		1
15	F05005-101	Bolt, 1/4-20 x 1 Hex Head Grade 5		1
16	F05011-11	Washer, 1/4" SAE Flat		4
17	F05010-69	Nut, 1/4-20 Nylon Lock		1
18	006881	Plate, Lower ALternator Cover		1
19	F05005-15	Bolt, 1/4-20 x 1/2" Hex Head		2
20	F05011-14	Washer, 1/4" Split Lock		2
21	F05007-27	Bolt, 3/8-16 x 3/4 Hex Head Grade 2		1
22	F05011-4	Washer, 3/8" Split Lock		1
23	006524	Belt, 6PK1145 Alternator		1
	050941	Wire Assembly, Alternator Ground		1

3.17 Alternator Assembly (11/2008 - 2/2010)

LT70HDs Rev. B2.00 - B3.02

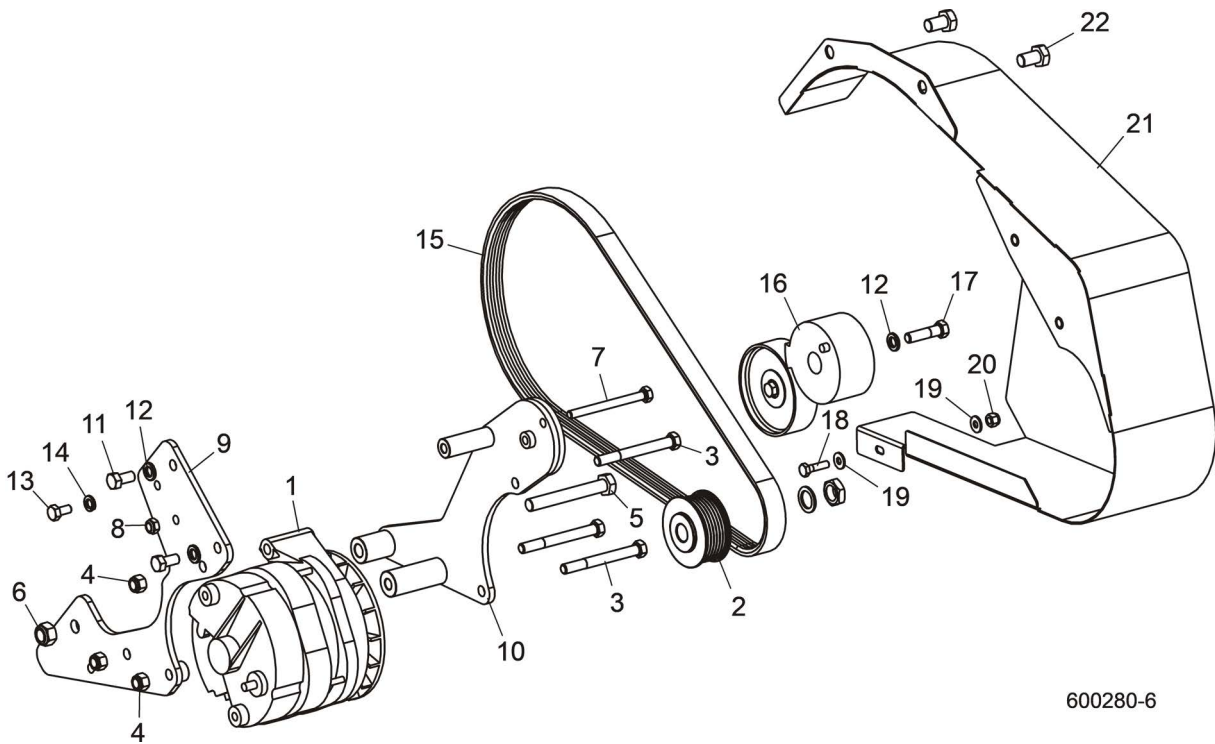

600280-6

REF	PART #	DESCRIPTION	COMMENTS	QTY.
	024537	Wire Assembly, Alternator Plug		1
	034500	Alternator Assembly, 190 Amp		1
1	034499	Alternator, 190 Amp	Available in assemblies only.	1
2	046402	Pulley, 2 3/4" O.D. Alternator		1
3	F05004-123	BOlt, 3/8-16 x 3 1/2" Hex Head Grade 5		3
4	F05010-10	Nut, 3/8-16 Hex Nylon Lock		3
5	F05004-249	Bolt, M12 x 1.75 x 90mm Hex Head Full thread		1
6	F05010-209	Nut, M12 x 1.75 Hex Nylon Lock		1
7	F05004-247	Bolt, M8 x 1.25 x 90mm Hex Head Full thread		1
8	F05010-132	Nut, M8 Hex Nylon Lock		1
9	058708	Bracket WEldment, Yanmar Alternator Mount		1
10	057493	Bracket Weldment, Yanmar Alternator Tensioner Mount		1
11	F05007-27	Bolt, 3/8-16 x 3/4 Hex Head Grade 2		2
12	F05011-4	Washer, 3/8" Split Lock		3
13	F05004-47	Bolt, M8 x 125 x 16mm Hex Head		1
14	F05011-45	Washer, 8mm Split Lock		1
15	006524	Belt, 6PK1145 Alternator	Part number corrected 2/10 (was 034513).	1
16	034464	Tensioner, Alternator Belt		1
17	F05007-78	Bolt, 3/8-16 x 1 1/2" Hex Head Grade 5		1
18	F05005-101	Bolt, 1/4-20 x 1 Hex Head Grade 5		1
19	F05011-11	Washer, 1/4" SAE Flat		2

REF	PART #	DESCRIPTION	COMMENTS	QTY.
20	F05010-69	Nut, 1/4-20 Nylon Lock		1
21	006565	Guard Weldment, Yanmar 55HP Alternator Belt		1
22	F05004-251	Bolt, M12 x 1.75 x 20mm Hex Head Full Thread		2
	050941	Wire Assembly, Alternator Ground		1

3.18 Engine Pulley Guards

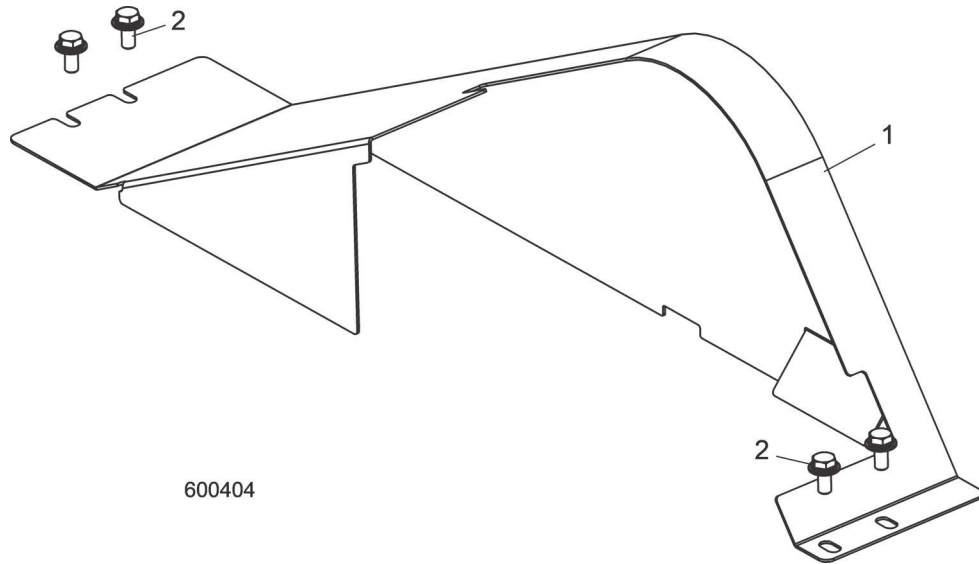

REF	PART #	DESCRIPTION	COMMENTS	QTY.
1	075640	Cover Weldment, D55 Top Pulley Belt	075640 replaced 065520 supplied prior to Rev. B6.01 which replaced 034520 supplied prior to Rev. B4.07. New covers work for standard and wide heads.	1
1	079342	Weldment, LT70 T4 Top Pulley Cover	T4 engines only	1
2	F05006-101	Bolt, 5/16-18 x 3/4" Hex Head with washers		4

3.19 Bearing Support (Non-Super)

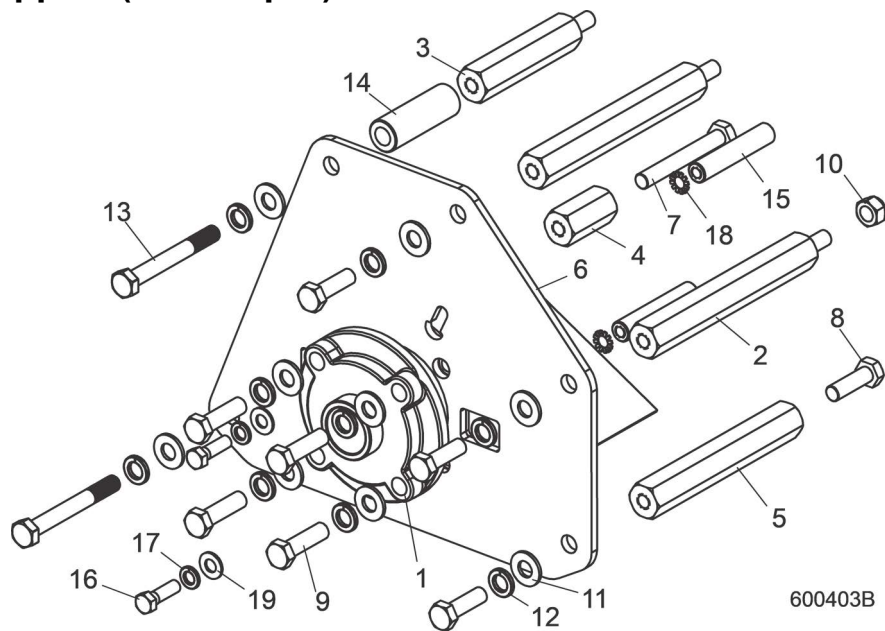

REF	PART #	DESCRIPTION	COMMENTS	QTY.
	074265	Support Assembly, Yanmar 55HP BearinG	Use 075746 Support Kit to upgrade Yanmar D55 engines supplied prior to 1/14.	1
1	071491	Bearing, 1-7/16 4-Bolt Flange		1
2	071493	Spacer, 1 Hex x 7.31		2
3	071499	Spacer, 1 Hex x 4.38		1
4	075103	Spacer, 1 Hex x 2.03		1
5	075104	Spacer, 1 Hex x 6.63		1
6	075638	Support Weldment, Yanmar 55HP Bearing		1
7	F05004-249	Bolt, M12 x 1.75 x 90mm Hex Head Full Thread Cl10.9 Zinc		1
8	F05004-250	Bolt, M12 x 1.75 x 40mm Hex Head Full Thread Cl10.9 Zinc		4
9	F05008-102	Bolt, 1/2-13x2 HH Gr5	Replaced (4) F05008-88 after 4/24/24 per ECN 39373	4
	F05008-88	Bolt, 1/2-13 x 1 3/4" Hex Head Grade 5 Full		4
10	F05010-209	Nut, M12 x 1.75 Hex Nylock Zinc		1
11	F05011-2	Washer, 1/2" SAE Flat		10
12	F05011-9	Washer, 1/2" Split Lock		10
13	F05023-7	Bolt, M12-1.75 x 100 Grade 8.8 Hex Head		2
14	074529	Spacer, 9/16 x 1x 2.94 Painted		1
15	074751	Rod, LT70 Clutch Enhancement	Adjust clutch enhancement rods 074751 approx. 1/4" from drive belt when tensioned. Added(Rev. B6.04).	2
16	F05007-123	Bolt, 3/8-16 x 1 1/4" Full Thread Hex Head Grade 5		2
17	F05011-4	Washer, 3/8 Split Lock		2
18	F05011-36	Washer, 3/8 Star External		2
19	F05011-3	Washer, 3/8 Flat SAE		2

3.20 Bearing Support (Super Tier 3)

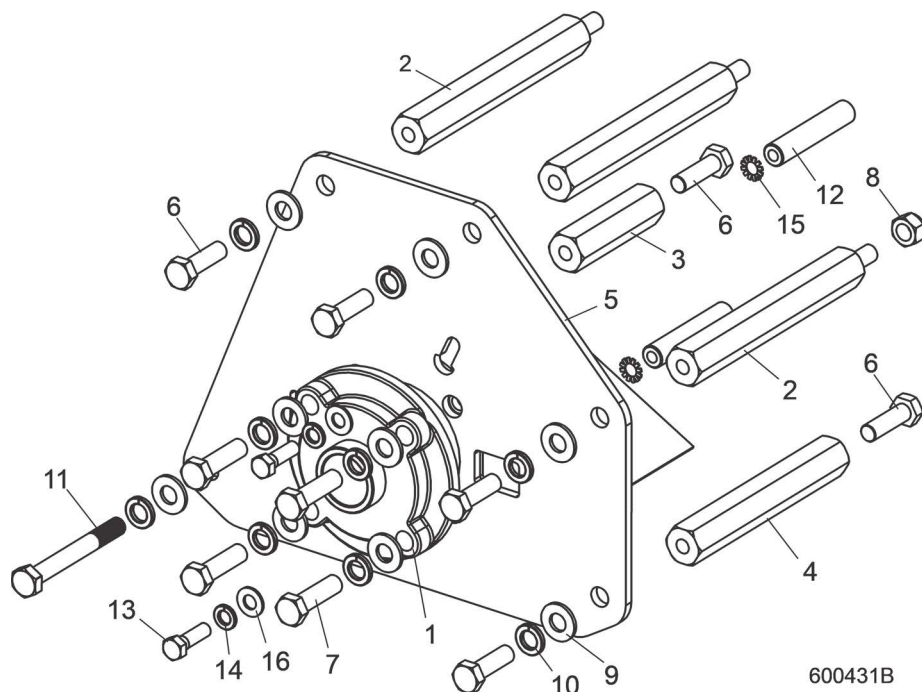

REF	PART #	DESCRIPTION	COMMENTS	QTY.
	074515	Support Assembly, LT70 Hydraulic Yanmar 55HP Bearing		1
1	071491	Bearing, 1-7/16 4-Bolt Flange		1
2	071493	Spacer, 1 Hex x 7.31		3
3	074516	Spacer, 1 Hex x 3.64		1
4	075104	Spacer, 1 Hex x 6.63		1
5	075638	Weldment, Yanmar 55HP Bearing Support		1
6	F05004-250	Bolt, M12 x 1.75 x 40mm Hex Head Full Thread Cl10.9 Zinc		6
7	F05008-102	Bolt, 1/2-13x2 HH Gr5	Replaced (4) F05008-88 after 11/21/23 per ECN 39219	4
	F05008-88	Bolt, 1/2-13 x 1 3/4" Hex Head Grade 5 Full Thread		4
8	F05010-209	Nut, M12 x 1.75 Hex Nylock Zinc		1
9	F05011-2	Washer, 1/2" SAE Flat		9
10	F05011-9	Washer, 1/2" Split Lock		9
11	F05023-7	Bolt, M12-1.75 x 100 Grade 8.8 Hex Head		1
12	074751	Rod, LT70 Clutch Enhancement		2
13	F05007-123	Bolt, 3/8-16 x 1 1/4" Full Thread Hex Head Grade 5		2
14	F05011-4	Washer, 3/8 Split Lock		2
15	F05011-36	Washer, 3/8 Star External		2
16	F05011-3	Washer, 3/8 Flat SAE		2

3.21 Bearing Support (Super Tier 4)

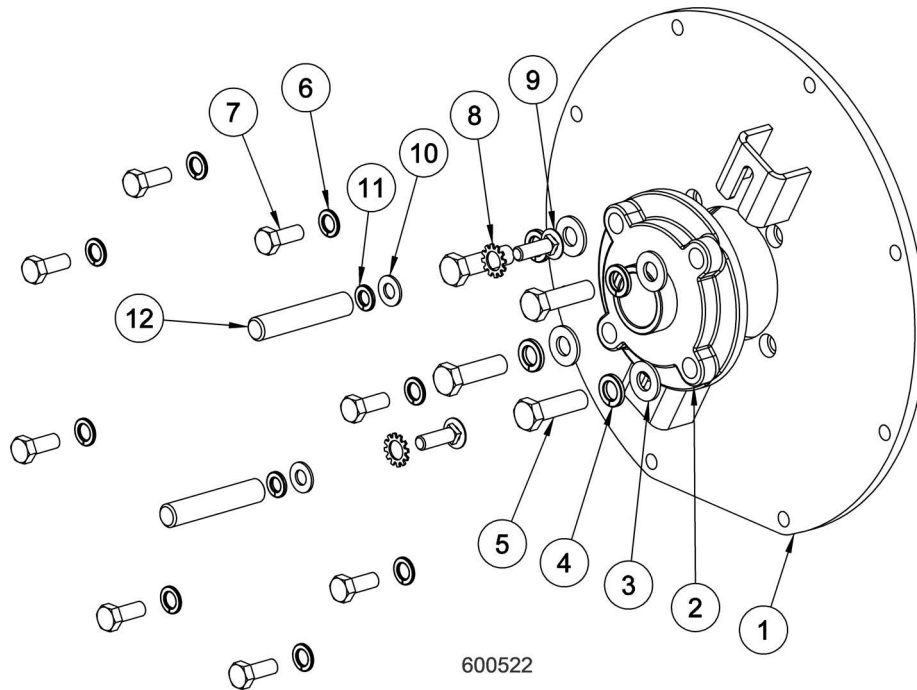

REF	PART #	DESCRIPTION	COMMENTS	QTY.
	079262	Assembly, D46 T4 Final Bearing Support		1
1	079261	Weldment, D46 T4 Final Bearing Support		1
2	071491	Bearing, 1-7/16 4-Bolt Flange		1
3	F05011-2	Washer, 1/2 SAE Flat		4
4	F05011-9	Washer, 1/2 Split Lock		4
5	F05008-102	Bolt, 1/2-13x2 HH Gr5	Replaced (4) F05008-88 after 4/24/24 per ECN 39373	4
	F05008-88	Bolt, 1/2-13x1 3/4 Hex HeadGR5 FT Zinc		4
6	F05011-88	Washer, 10MM Split Lock		8
7	F81003-11	Bolt, M10-1.5x25 Hex Head Cl 8.8		8
8	F05011-39	Washer, 1/2 Star ET		2
9	F05007-127	Bolt, 3/8-16x1 1/4 Carriage Gr5		2
10	F05011-3	Washer, 3/8 Flat SAE		2
11	F05011-4	Washer, 3/8 Split Lock		2
12	074751	Rod, LT70 Clutch Enhancement		2

3.22 Flywheel Cover Assembly (Super Only)

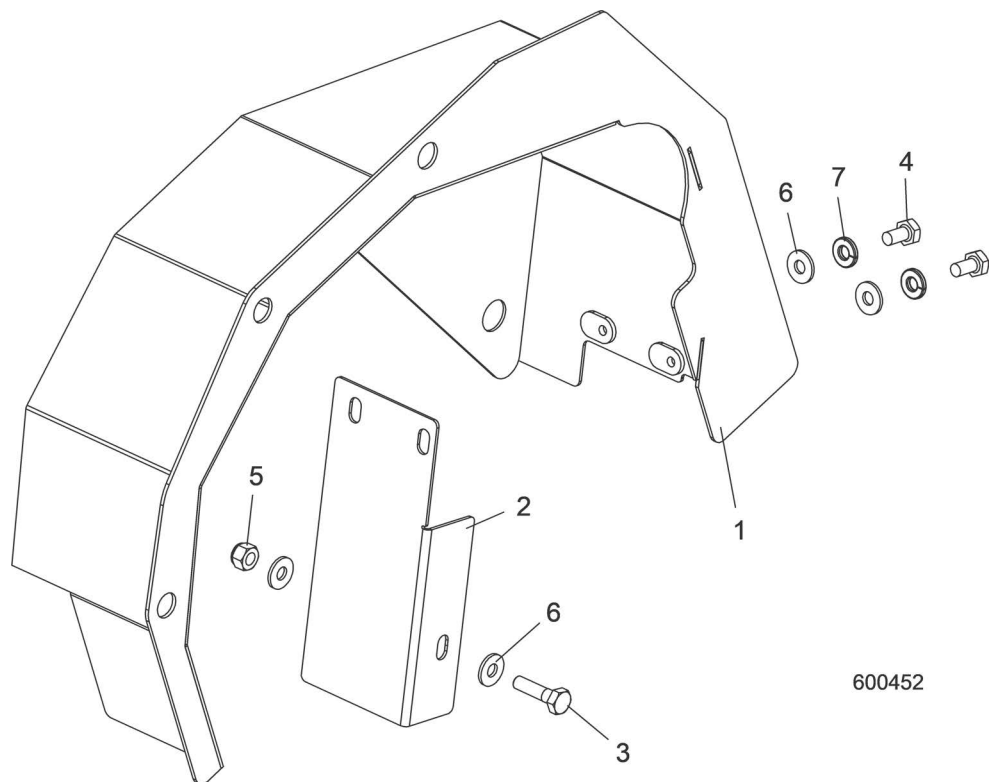

REF	PART #	DESCRIPTION	COMMENTS	QTY.
	074513	Cover Assembly, LT70 Hydraulic 55HP Flywheel		1
1	075313	Cover Weldment, LT70 Hydraulic Flywheel Cover		1
2	075314	Plate, LT70 Hydraulic Lower Flywheel Cover		1
3	F05005-101	Bolt, 1/4-20 x 1" Hex Head Grade 5		1
4	F05005-15	Bolt, 1/4-20 x 1/2" Hex Head		2
5	F05010-69	Nut, 1/4-20 Nylon Lock		1
6	F05011-11	Washer, 1/4" SAE Flat		4
7	F05011-14	Washer, 1/4" Split Lock		2

3.23 Drive Belt Guard Assembly

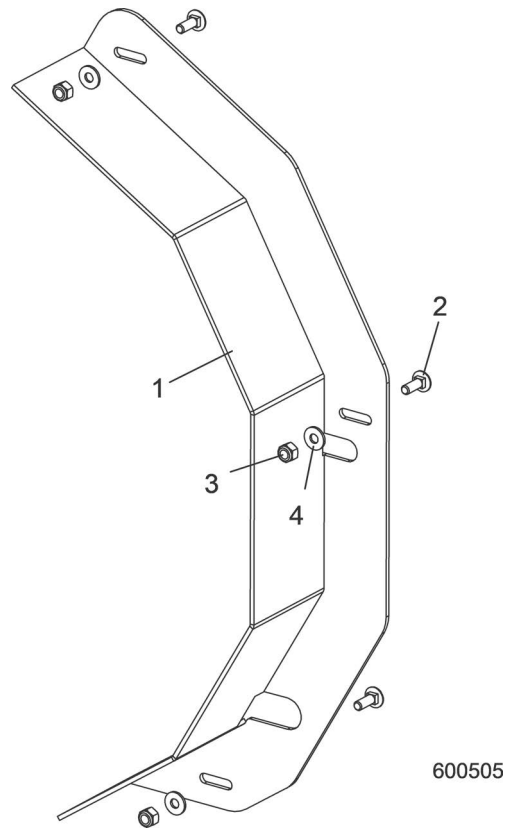

REF	PART #	DESCRIPTION	COMMENTS	QTY.
	079141	Guard Assembly, LT70 Drive Belt	Located inside the sawhead	1
1	079132	Guard Weldment, LT70 Drive Belt Guard		1
2	F05005-113	Bolt, 1/4-20x3/4 Carriage		3
3	F05010-69	Nut, 1/4-20 Nylock		3
4	F05011-11	Washer, 1/4 SAE Flat		3