

LT28 D19 Engine

Safety, Operation, Maintenance & Parts Manual

038576 Engine, 19HP Deutz Diesel rev. C

Safety is our #1 concern!

Form #1351

**Used with:
LT28D19 rev. A1.02 - A6.02**



WARNING! Read and understand this manual before using this machine.

California
Proposition 65 Warning



WARNING: Breathing gas/diesel engine exhaust exposes you to chemicals known to the State of California to cause cancer and birth defects or other reproductive harm.

Always start and operate the engine in a well-ventilated area.
If in an enclosed area, vent the exhaust to the outside.
Do not modify or tamper with the exhaust system.
Do not idle the engine except as necessary.

For more information go to **www.P65warnings.ca.gov**.



WARNING: Drilling, sawing, sanding or machining wood products can expose you to wood dust, a substance known to the State of California to cause cancer. Avoid inhaling wood dust or use a dust mask or other safeguards for personal protection.

For more information go to **www.P65Warnings.ca.gov/wood**.

Active Patents assigned to Wood-Mizer, LLC

Wood-Mizer, LLC has received patents that protect our inventions which are a result of a dedication to research, innovation, development, and design. Learn more at: woodmizer.com/patents

©2023 Wood-Mizer LLC

Printed in the United States of America, all rights reserved. No part of this manual may be reproduced in any form by any photographic, electronic, mechanical or other means or used in any information storage and retrieval system without written permission from

Wood-Mizer, LLC
8180 West 10th Street
Indianapolis, Indiana 46214

SECTION 1 OPERATION AND MAINTENANCE

1.1 Starting The Engine 1-1
1.2 Safety 1-1
1.3 Battery 1-2
1.4 Fuel Filter 1-2
1.5 RPM Adjustments 1-2

SECTION 2 REPLACEMENT PARTS

2.1 Fuel Tank 2-1
3.2 Engine Assembly 3-1
3.3 Throttle/Clutch Assembly 3-3

ABOUT THIS MANUAL

This manual is provided as a supplement to the equipment manufacturer's manuals. This manual provides information specific to the use of this equipment on the Wood-Mizer® sawmill. Refer to the sawmill operator's manual and manufacturer's manual before attempting to operate this equipment.

NOTICE Read the sawmill operator's manual and engine manufacturer's manual for instructions and safety precautions before operating this equipment.

The information and instructions given in this manual do not amend or extend the limited warranties for the equipment given at the time of purchase.

SECTION 1 OPERATION AND MAINTENANCE

1.1 Starting The Engine



DANGER! Always be sure the blade is disengaged and clear the path of the blade before starting the engine. Failure to do so will result in serious injury or death.

DANGER! Operate your engine/machine only in well ventilated areas. Exhaust gases can cause nausea, delirium and potentially death unless adequate ventilation is present.

DANGER! Never operate an engine with a fuel or oil leak. The leaking fuel or oil could potentially come in contact with hot surfaces and ignite into flames.



WARNING! Do not operate engine without proper and operational spark arrester/muffler. Sparks emitted from the engine exhaust could ignite surrounding materials, causing serious injury or death.



CAUTION! EPA Compliant Gas Tanks Only: Always relieve all fuel pressure inside the tank prior to filling or connecting fuel fittings. Failure to do so may result in fuel spillage.

CAUTION! EPA Compliant Gas Tanks Only: Disconnect the fuel tank when not in use, or engine flooding or fuel spillage may result

1. See the engine manufacturer's manual for lubricating oil recommendations for specific temperature ranges.
2. Use #2 or better quality diesel fuel for above freezing starting. Use a #1 quality diesel fuel for below freezing starting.
3. Turn the key switch to the on (#1) position.
4. Turn the key switch to the start (#2) position and release.

ENGINE SHUTOFF

1. Disengage the clutch handle to stop the blade if necessary.
2. Turn the key switch to the off (#0) position.

Refer to the manufacturer's manual for maintenance intervals and procedures unless otherwise instructed in this manual. Follow the manufacturer's recommendations for dusty conditions.

NOTICE This manual only provides information about additional procedures or procedures to be performed at different time intervals than found in the manufacturer's manuals. Refer to the manufacturer's manual for complete maintenance instructions.

1.2 Safety

Use caution when performing maintenance or service to the engine.

 **DANGER!** Always be aware of and take proper protective measures against rotating shafts, pulleys, fans, etc.

Always stay a safe distance from rotating members and make sure that loose clothing or long hair does not engage rotating members.

Never touch or perform service functions on a hot engine.

 **WARNING!** Remove the blade before performing any engine service. Failure to do so may result in serious injury.

Wear proper (eye, breathing, hand, and foot) safety equipment when performing service functions.

Clean sawdust from all guards, vents, control boxes, or any area where sawdust may gather **after every shift**. Failure to do so may result in fire, causing death or serious injury.



1.3 Battery

Check the battery electrolyte level every 50 hours of operation. See manufacturer's manual for instructions.

 **DANGER!** Batteries expel explosive gases.

Keep sparks, flames, burning cigarettes, or other ignition sources away at all times.

Wear a face shield when working on batteries.

 **WARNING!** Battery posts, terminals and related accessories contain lead and lead compounds. Wash hands after handling.

1.4 Fuel Filter

Replace the fuel filter **every 100 hours** of operation or as required for engine performance.

1.5 RPM Adjustments

 **WARNING!** Remove the blade before performing any engine service. Failure to do so may result in serious injury.

1. Check the RPM with a tachometer every 200 hours of operation.

Engine	High End RPM	Low End RPM
D19	3600	1500

2. Before checking the RPM, make sure belt and brake strap tensions are correct (See Sawmill Maintenance).
3. Check oil, fuel, and coolant levels.
4. Check that the throttle cable does not affect the engine RPM when the clutch handle is disengaged.
5. Ensure the cable is not bent or kinked.

SECTION 2 REPLACEMENT PARTS

2.1 Fuel Tank

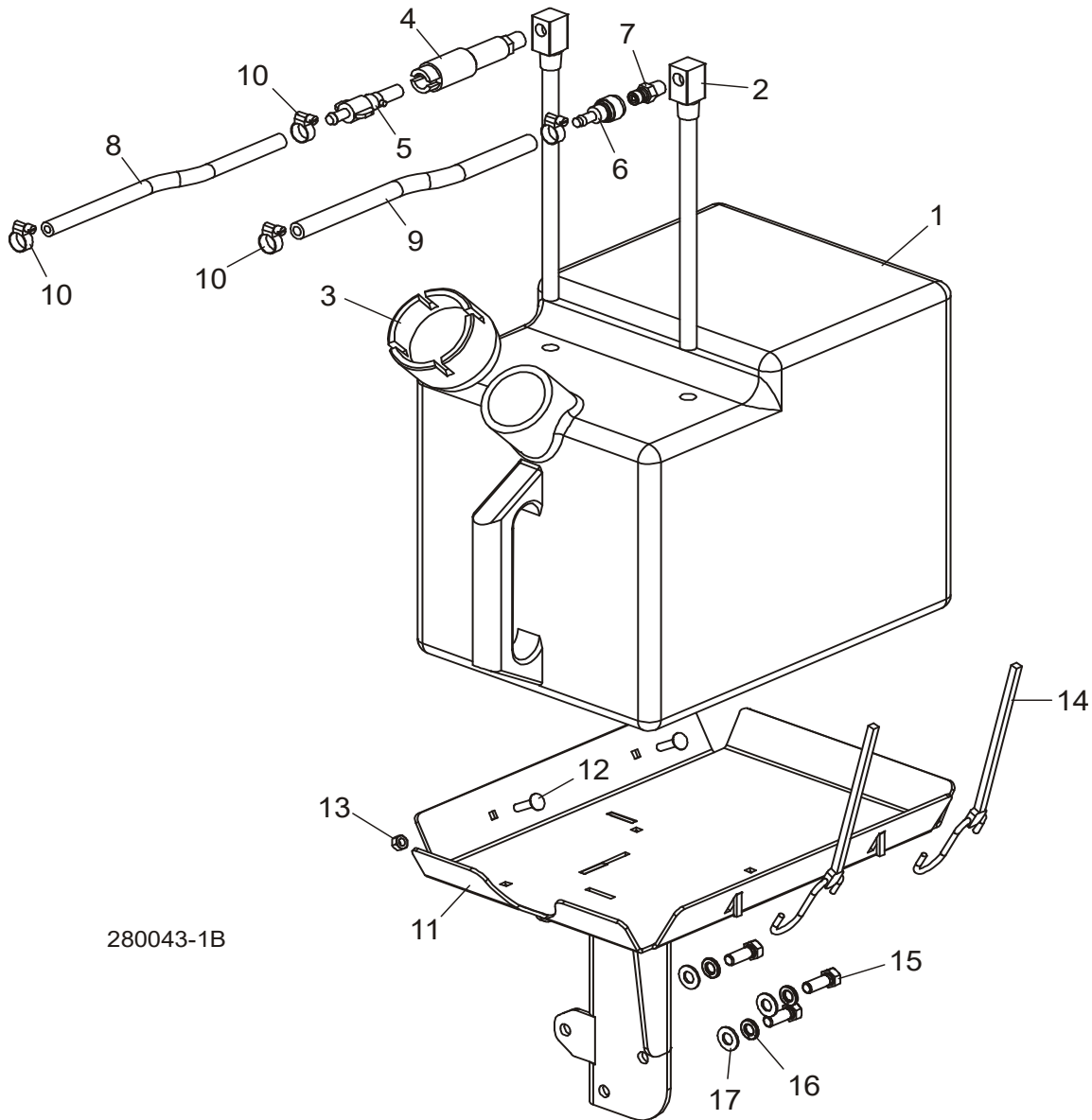

280043-1B

REF	PART #	DESCRIPTION	COMMENTS	QTY.
	038580	TRAY ASSEMBLY, LT28 DIESEL CAN		1
	A12132	Tank Assembly, 5-Gallon Diesel Fuel		1
1	P12166	Tank, 5-Gallon Diesel Fuel	Available in assemblies only.	1
2	P12172	Pickup, 9" Fuel		2
3	P09683	Cap, 3 or 5-Gallon Fuel Tank		1
4	P12175	Fitting, 1/4" NPT Plastic Female Disconnect		1
5	P12176	Fitting, 1/4" NPT Plastic Male Disconnect		1
6	015582	Fitting, Female Quick Disconnect Barb		1
7	015583	Fitting, 1/4" NPT Male Quick Disconnect		1
8	P642	Hose, 1/4" ID Fuel		5.5 Ft

REF	PART #	DESCRIPTION	COMMENTS	QTY.
9	016338	Hose, 5/16" Fuel Line		8 Ft
10	P649	Clamp, 7/32 - 1/2 Hose		4
11	049137	Tray Weldment, LT28 Fuel		1
12	F05005-34	Bolt, 1/4-20 X 1" Carriage		2
13	F05010-21	Nut, 1/4-20 Swaged		2
14	P11258	Strap, 24 Rubber W/Hooks		2
15	F05007-87	Bolt, 3/8-16 x 1" Hex Head Grade 5		3
16	F05011-4	Washer, 3/8" Split Lock		3
17	F05011-3	Washer, 3/8" SAE Flat		3

3.2 Engine Assembly

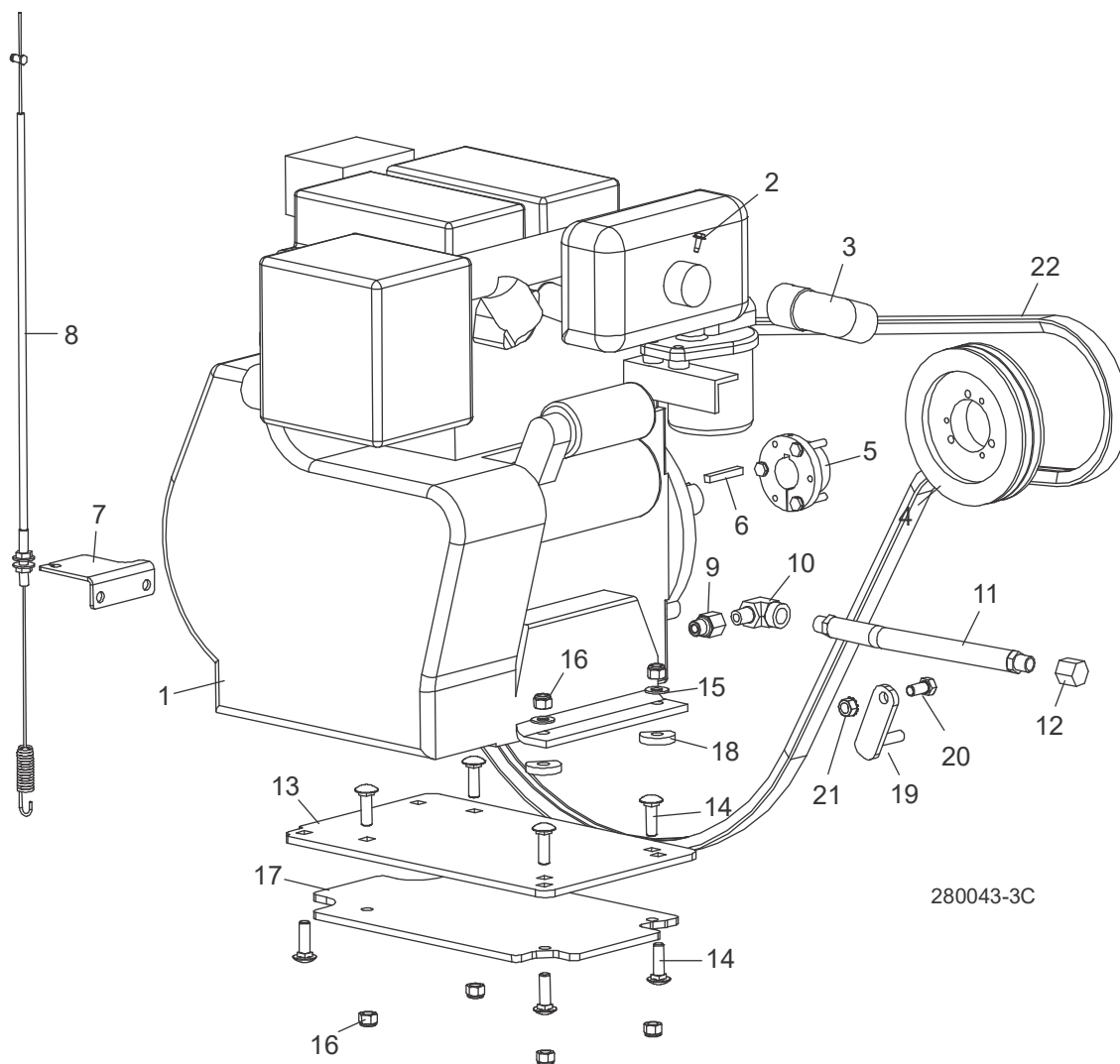

REF	PART #	DESCRIPTION	COMMENTS	QTY.
	038576	ENGINE ASSEMBLY, LT28 19HP DIESEL		1
1	049387	Engine, 19HP Deutz Diesel	Available in assemblies only.	1
	054911	Filter, Air #7700 175 180480		1
	054912	Pump, Fuel #7700 6521 180420		1
	054913	Filter, Oil #7700 217 52020		1
	054914	Starter, Engine #7700 563 180540		1
	054915	Shutdown, Engine #7700 674 180470		1
	014209	Filter, Fuel		1
2	F05015-7	Screw, #10-24 x 1/2" Self-Tapping		1
3	038590	Deflector, 1 1/4" ID Exhaust D19		1
4	047742	Sheave, 3V5.6 x 2-SH		1
5	038432	Bushing, SH x 1 1/8"		1
6	S04124	Key, 1/4" x 1 11/16"		1
7	049399	Plate, Throttle D19		1
8	049406	Cable, LT15/LT28 D19		1
9	038584	Fitting, M14x1.5 Male-1/4 NPT Female		1

REF	PART #	DESCRIPTION	COMMENTS	QTY.
10	038571	Fitting, 1/4" NPT Male 90 Deg 3/8" NPT Fem		1
11	P10082	Hose, 3/8" NPT x 9 5/8" Rubber		1
12	P04332	Cap, 3/8 Pipe Galvanize		1
13	049389	Plate, Engine Mount D19		1
14	F05007-127	Bolt, 3/8-16 x 1 1/4" Carriage Gr5		8
15	F05011-3	Washer, 3/8" Flat SAE		4
16	F05010-10	Nut, 3/8-16 Hex Nylon Lock		8
17	038572	Plate, 1/4" Spacer D19		1
18	038573	Spacer, 13/32" ID x 1 1/4" OD x 1/4"		4
19	048237	SUPPORT WELDMENT, DRIVE BELT		1
20	F05007-118	BOLT, 3/8-16 X 3/4" HEX HEAD GRADE 5		1
21	F05010-19	NUT, 3/8-16 SELF-LOCKING HEX		1
22	047751	BELT, 2/3VFL900 DRIVE		1

3.3 Throttle/Clutch Assembly

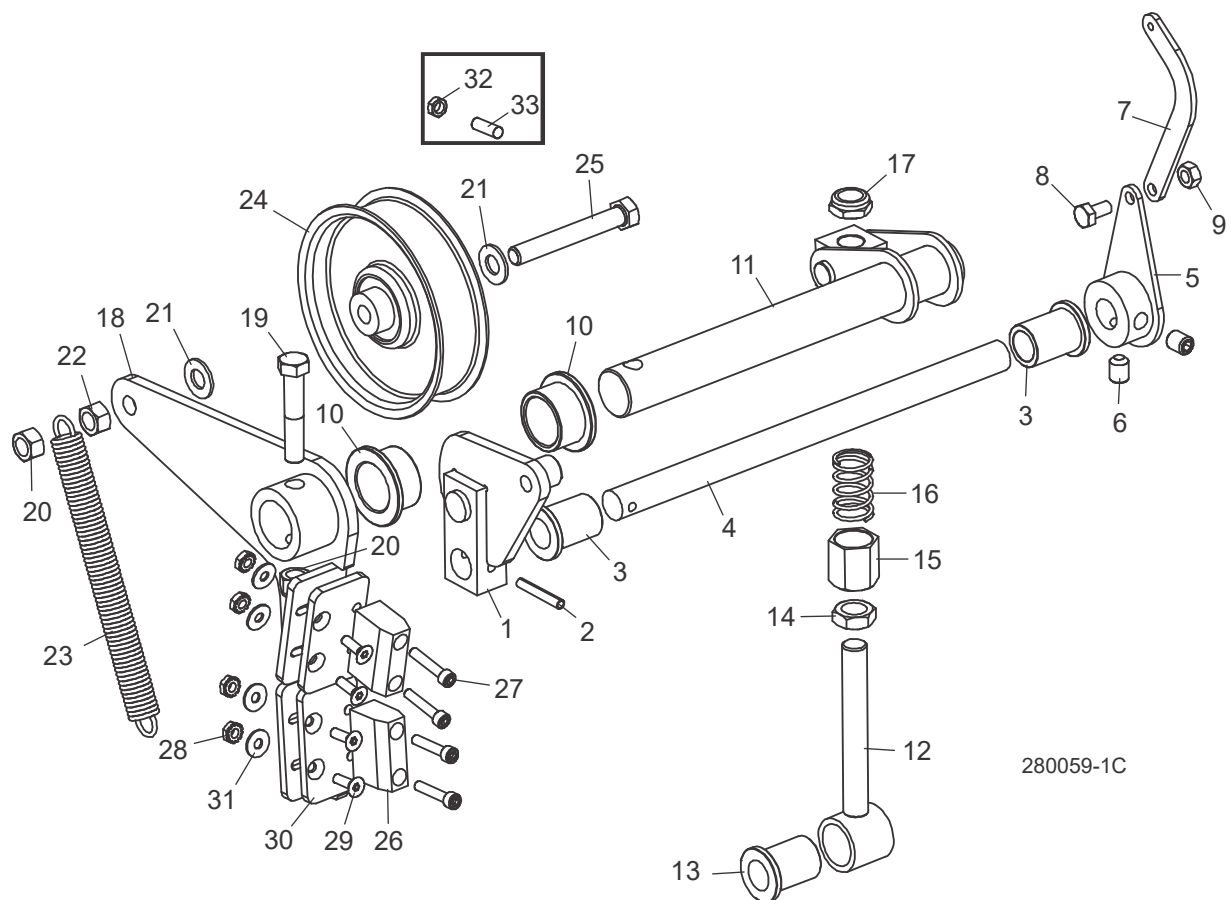

REF	PART #	DESCRIPTION	COMMENTS	QTY.
1	065574	BLOCK WELDMENT, LINKAGE CLUTCH/BRAKE	Replaces 049139 to make clutch pivot stop adjustable (Rev. A6.05). Tab on Clutch/Brake Block Weldment 049139 modified to provide increased brake adjustment and reduce need for clutch turn-buckle adjustment (Rev. A3.00).	1
2	F05012-16	PIN, 3/16" X 1 1/4" ROLL		1
3	016486	BUSHING, 5/8" ID X 7/8" OD X 1 1/4" LONG FL BRONZE		2
4	049340	SHAFT, LT28 THROTTLE		1
5	034815	ACTUATOR WELDMENT, THROTTLE LT15D&G		1
6	F05007-68	SCREW, 3/8-16 X 3/8" SOCKET HEAD CUP PT SET		2
7	034818	LINKAGE, THROTTLE LT15D&G		1
8	F05005-15	BOLT, 1/4-20 X 1/2" HEX HEAD		1
9	F05010-21	NUT, 1/4-20 SWAGED		1
10	P737	BUSHING, 1" X 1 1/4" X 3/4" FLANGED BRONZE		2
11	034608	PIVOT WELDMENT, CLUTCH/BRAKE		1
	034605	LINKAGE ASSEMBLY, W/BEARING		1
12	034604	Boss Weldment, Clutch/Brake Linkage		1
13	016486	Bushing, 5/8" ID x 7/8" OD x 1 1/4" Long Flanged Bronze		1

REF	PART #	DESCRIPTION	COMMENTS	QTY.
	038778	NUT ASSEMBLY, 1/2-13 SPRING LOCKING	Spring Locking Nut Assembly 038778 added Rev. A3.00 to allow engine acceleration prior to blade engagement (replaces F05010-35 1/2-13 Hex Nut and F05011-9 1/2" Split Lock Washer).	1
14	F05010-31	Nut, 1/2-13 Hex Jam		1
15	038777	Nut, 1/2-13 Spring Lock		1
16	046975	Spring, .72" OD x .576" ID x 1.25L Compression		1
17	F05010-127	Nut, 1/2-13 Half Nylon Lock		1
	065874	BRAKE/CLUTCH ASSEMBLY		1
18	065873	Arm Weldment, Clutch/Brake		1
19	F05007-124	Bolt, 3/8-16 x 2 Hex Head Grade 5		1
20	F05010-10	Nut, 3/8-16 Hex Nyl Lock		2
21	F05011-3	Washer, 3/8" Flat SAE		3
22	F05010-25	Nut, 3/8-16 Swaged		1
23	034810	Spring, Idler Arm LT15/D/E/G		1
24	034602	Idler, 4" O.D. x 3/8" Bore		1
25	F05007-125	Bolt, 3/8-16 x 2-1/2" Hex Head Grade 5		1
26	016488	Block, LT15 Brake		2
27	F05004-2	Bolt, #10-24 x 1" Socket Head Cup		4
28	F05010-14	Nut, #10-24 Keps		8
29	F05004-282	Screw, 10-24 x 5/8" FSHC		4
30	065872	Plate, Brake Adjustment		2
31	F05011-18	Washer, #10 SAE Flat		4
32	F05010-29	NUT, 3/8-16 JAM		1
33	F05007-18	SCREW, 3/8-16 X 1 1/4 SHOP SET		1