



# Wood-Mizer<sup>®</sup> Sawmill

## Parts Manual

---

LT15

rev. A1.00 - E3.02

---



**Safety is our #1 concern!** Read and understand all safety information and instructions before operating, setting up or maintaining this machine.

*January 1999*

*Form #851*

# Table of Contents

# Section-Page

<b>SECTION 1</b>	<b>GENERAL INFORMATION</b>	<b>1-1</b>
1.1	How To Use The Parts List .....	1-1
1.2	Sample Assembly .....	1-1
<b>SECTION 2</b>	<b>BLADE GUIDE ROLLERS &amp; ARM</b>	<b>2-1</b>
2.1	Blade Guide Assembly, Idle Side..... <i>LT15 Rev. D5.00 - E3.02</i>	2-1
2.2	Blade Guide Assembly, Idle Side..... <i>LT15 Rev. A1.00 - D4.01</i>	2-3
2.3	Blade Guide Assembly, Drive Side..... <i>LT15 Rev. D5.00 - E3.02</i>	2-5
2.4	Blade Guide Assembly, Drive Side..... <i>LT15 Rev. A1.00 - D4.01</i>	2-7
2.5	Blade Guide Arm.....	2-9
<b>SECTION 3</b>	<b>BLADE WHEELS &amp; TENSIONER</b>	<b>3-1</b>
3.1	Blade Drive Assembly.....	3-1
3.2	Idle Blade Wheel Assembly..... <i>LT15 Rev. C.00 - E3.02</i>	3-3
3.3	Idle Blade Wheel Assembly..... <i>LT15HA Rev. A.00 - B.00</i>	3-5
3.4	Blade Tensioner Assembly..... <i>LT15 Rev. E3.01 - E3.02</i>	3-7
3.5	Blade Tensioner Assembly..... <i>LT15 Rev. A1.00 - E3.00</i>	3-9
<b>SECTION 4</b>	<b>SAW HEAD</b>	<b>4-1</b>
4.1	Water Lube Assembly .....	4-1
4.2	Saw Head Decals.....	4-3
4.3	Blade Housing Covers & Wood Blocks.....	4-5
4.4	Battery Box Assembly .....	4-6
	<i>LT15 Rev. E2.00 - E3.02</i>	
	<i>LT15 Rev. A1.00 - E1.00</i>	
<b>SECTION 5</b>	<b>UP/DOWN SYSTEM</b>	<b>5-1</b>
5.1	Saw Head Mount & Blade Scales .....	5-1
5.2	Manual Crank Assembly .....	5-3
	<i>LT15 Rev. B.00 - E3.02</i>	
5.3	Manual Crank Assembly .....	5-4
	<i>LT15 Rev. A.00 - A.01</i>	
5.4	Sprocket Drive Assembly.....	5-6
<b>SECTION 6</b>	<b>FEED SYSTEM &amp; TRACK ROLLERS</b>	<b>6-1</b>
6.1	Track Rail, Rollers, & Travel Pins .....	6-1
	<i>LT15 Rev. D6.00 - E3.02</i>	

## Table of Contents

## Section-Page

6.2	Track Rail, Rollers, & Travel Pins .....	6-3	
	<i>LT15</i> <i>Rev. A1.00 - D5.00</i>		
6.3	Manual Feed .....	6-5	
<b>SECTION 7</b>	<b>BED FRAME ASSEMBLY</b>		<b>7-1</b>
7.1	Auxiliary Bed Rail Assembly .....	7-1	
7.2	Log Wedge, Loading Ramps, & Cant Hook (Optional).....	7-2	
7.3	Bed Connecting Hardware .....	7-3	
	<i>LT15</i> <i>Rev. B.00 - E3.02</i>		
7.4	Bed Connecting Hardware .....	7-4	
	<i>LT15BS</i> <i>Rev. A.00</i>		
7.5	Leg Assembly .....	7-5	
	<i>LT15BS</i> <i>Rev. E.00+</i>		
7.6	Leg Assembly .....	7-6	
	<i>LT15BS</i> <i>Rev. A.00 - D.06</i>		
7.7	Log Side Support Assembly .....	7-7	
7.8	Log Clamp .....	7-8	
	<i>LT15</i> <i>Rev. E3.02</i>		
7.9	Log Clamp .....	7-9	
	<i>LT15</i> <i>Rev. D6.00 - E3.01</i>		
7.10	Log Clamp .....	7-10	
	<i>LT15</i> <i>Rev. A1.00 - D5.00</i>		
<b>SECTION 8</b>	<b>MISCELLANEOUS</b>		<b>8-1</b>
8.1	Replacement Manuals .....	8-1	
	<b>INDEX</b>		<b>I</b>

# Table of Contents

# Section-Page

<b>SECTION 1</b>	<b>GENERAL INFORMATION</b>	<b>1-1</b>
1.1	How To Use The Parts List .....	1-1
1.2	Sample Assembly .....	1-1
<b>SECTION 2</b>	<b>BLADE GUIDE ROLLERS &amp; ARM</b>	<b>2-1</b>
2.1	Blade Guide Assembly, Idle Side..... <i>LT15 Rev. D5.00+</i>	2-1
2.2	Blade Guide Assembly, Idle Side..... <i>LT15 Rev. A1.00 - D4.01</i>	2-3
2.3	Blade Guide Assembly, Drive Side..... <i>LT15 Rev. D5.00+</i>	2-5
2.4	Blade Guide Assembly, Drive Side..... <i>LT15 Rev. A1.00 - D4.01</i>	2-7
2.5	Blade Guide Arm.....	2-9
<b>SECTION 3</b>	<b>BLADE WHEELS &amp; TENSIONER</b>	<b>3-1</b>
3.1	Blade Drive Assembly.....	3-1
3.2	Idle Blade Wheel Assembly .....	3-3
	<i>LT15HA Rev. C.00+</i>	
3.3	Idle Blade Wheel Assembly .....	3-5
	<i>LT15HA Rev. A.00 - B.00</i>	
3.4	Blade Tensioner Assembly.....	3-7
	<i>LT15 Rev. E3.01+</i>	
3.5	Blade Tensioner Assembly.....	3-9
	<i>LT15 Rev. A1.00 - E3.00</i>	
<b>SECTION 4</b>	<b>SAW HEAD</b>	<b>4-1</b>
4.1	Water Lube Assembly .....	4-1
4.2	Saw Head Decals.....	4-2
4.3	Blade Housing Covers & Wood Blocks.....	4-4
4.4	Battery Box Assembly .....	4-5
	<i>LT15 Rev. E2.00+</i>	
	<i>LT15 Rev. A1.00 - E1.00</i>	
<b>SECTION 5</b>	<b>UP/DOWN SYSTEM</b>	<b>5-1</b>
5.1	Saw Head Mount & Blade Scales .....	5-1
5.2	Manual Crank Assembly .....	5-3
	<i>LT15 Rev. B.00+</i>	
5.3	Manual Crank Assembly .....	5-4
	<i>LT15 Rev. A.00 - A.01</i>	
5.4	Sprocket Drive Assembly.....	5-6
<b>SECTION 6</b>	<b>FEED SYSTEM &amp; TRACK ROLLERS</b>	<b>6-1</b>
6.1	Track Rail, Rollers, & Travel Pins .....	6-1
	<i>LT15 Rev. D6.00+</i>	

<b>Table of Contents</b>	<b>Section-Page</b>
6.2 Track Rail, Rollers, & Travel Pins .....	6-3
<i>LT15 Rev. A1.00 - D5.00</i>	
6.3 Manual Feed .....	6-5
<b>SECTION 7 BED FRAME ASSEMBLY</b>	<b>7-1</b>
7.1 Auxiliary Bed Rail Assembly .....	7-1
7.2 Log Wedge, Loading Ramps, & Cant Hook (Optional).....	7-2
7.3 Bed Connecting Hardware .....	7-3
<i>LT15BS Rev. B.00+</i>	
7.4 Bed Connecting Hardware .....	7-4
<i>LT15BS Rev. A.00</i>	
7.5 Leg Assembly .....	7-5
7.6 Log Side Support Assembly & Decal .....	7-6
7.7 Log Clamp .....	7-7
<i>LT15 Rev. E3.02+</i>	
7.8 Log Clamp .....	7-8
<i>LT15 Rev. D6.00 - E3.01</i>	
7.9 Log Clamp .....	7-9
<i>LT15 Rev. A1.00 - D5.00</i>	
<b>SECTION 8 MISCELLANEOUS</b>	<b>8-1</b>
8.1 Replacement Manuals .....	8-1
<b>INDEX</b>	<b>I</b>

## SECTION 1 GENERAL INFORMATION

### 1.1 How To Use The Parts List

- Use the table of contents or index to locate the assembly that contains the part you need.
- Go to the appropriate section and locate the part in the illustration.
- Use the number pointing to the part to locate the correct part number and description in the table.
- Parts shown indented under another part are included with that part.
- Parts marked with a diamond (◆) are only available in the assembly listed above the part.

See the sample table below. Sample Part #A01111 includes part F02222-2 and subassembly A03333. Subassembly A03333 includes part S04444-4 and subassembly K05555. The diamond (◆) indicates that S04444-4 is not available except in subassembly A03333. Subassembly K05555 includes parts M06666 and F07777-77. The diamond (◆) indicates M06666 is not available except in subassembly K05555.

<b>1.2 Sample Assembly</b>				
REF	DESCRIPTION (◆ Indicates Parts Available In Assemblies Only)	PART #	QTY.	
	<b>SAMPLE ASSEMBLY, COMPLETE (INCLUDES ALL INDENTED PARTS BELOW)</b>	A01111	1	
1	Sample Part	F02222-22	1	
	Sample Subassembly (Includes All Indented Parts Below)	A03333	1	
2	Sample Part (◆ Indicates Part Is Only Available With A03333)	S04444-4	1	◆
	Sample Subassembly (Includes All Indented Parts Below)	K05555	1	
3	Sample Part (◆ Indicates Part Is Only Available With K05555)	M06666	2	◆
4	Sample Part	F07777-77	1	

#### To Order Parts:

- From the continental U.S., call **1-800-525-8100** to order parts. Have your customer number, vehicle identification number, and part numbers ready when you call.
- From other international locations, contact the Wood-Mizer distributor in your area for parts.

## SECTION 2 BLADE GUIDE ROLLERS & ARM

### 2.1 Blade Guide Assembly, Idle Side

LT15

Rev. D5.00 - E3.02

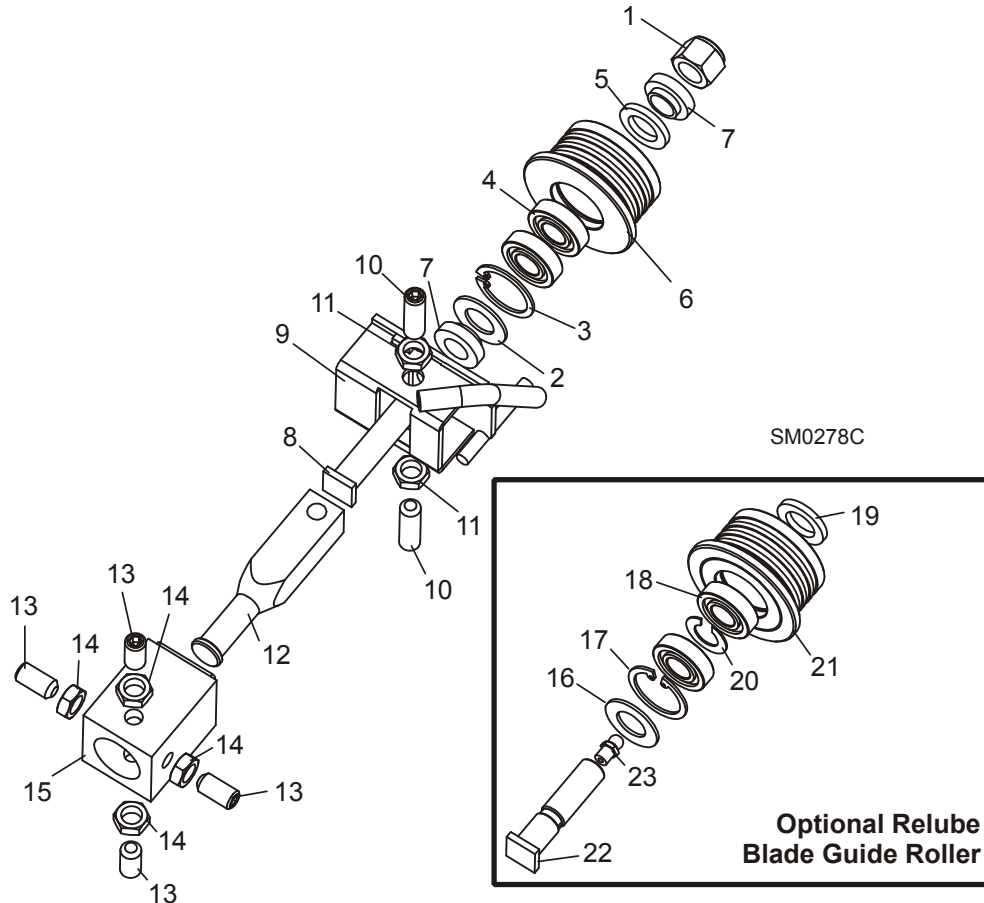

REF	DESCRIPTION (◆ Indicates Parts Available In Assemblies Only)	PART #	QTY.
	<b>BLADE GUIDE ASSEMBLY, COMPLETE IDLE SIDE</b>	A08197 <sup>1</sup>	1
1	Nut, 1/2-20 Hex Nylon Lock	F05010-15	1
	Roller Assembly, Blade Guide (standard)	A04925	1
	Bearing Kit, Blade Guide Rebuild	K07079	1
2	Washer, 5/8" White Felt	P04252	1
3	Ring, 1 1/8" Interior Retaining	F04254-1	1
4	Bearing, R8-2RS Blade Guide	015975	2 ◆
5	Washer, 5/8" Gray Felt	P06455	1
	Screw, 1/4-28 x 1/4" Socket Head Cup Point Set Black Oxide	F05005-105	1
	Instruction Sheet, Blade Guide Rebuild	057407-1507	1

## 2

**Blade Guide Rollers & Arm***Blade Guide Assembly, Idle Side*

6	Roller, Flanged Blade Guide	S04250	1	◆
	Instruction Sheet, Blade Guide Roller Replacement	A04925-364	1	
7	Spacer, Blade Guide	S04253	2	
8	Bolt, Blade Guide Roller	036373	1	
9	Bracket, Blade Guide Idle Side With Water Tube	W08495	1	
10	Screw, 3/8-24 X 1 1/4" Stainless Steel Socket Head Flat Point	F05007-96	2	
11	Nut, 3/8-24 Jam	F05010-22	2	
12	Shaft, Blade Guide Adjustment	S08196	1	
13	<b>SCREW, 3/8-24 X 3/4" STAINLESS STEEL SOCKET HEAD FLAT POINT</b>	F05007-95	4	
14	<b>NUT, 3/8-24 JAM</b>	F05010-22	4	
15	<b>TUBE, BLADE GUIDE MOUNT</b> ( <a href="#">See Section 2.5</a> )	W08159	1	
	<b>ROLLER ASSEMBLY, BLADE GUIDE RELUBE (OPTIONAL)</b>	016568	1	
	Bearing Kit, Relube Blade Guide Rebuild	057407	1	
16	Washer, 5/8" White Felt	P04252	1	
17	Ring, 1 1/8" Interior Retaining	F04254-1	1	
18	Bearing, R8-2RS Blade Guide	015975 <sup>2</sup>	2	◆
19	Washer, 5/8" Gray Felt	P06455	1	
20	Spacer, Blade Guide Bearing	035411	1	
	Instruction Sheet, Blade Guide Rebuild	057407-1507	1	
21	Roller, Flanged Blade Guide Relube	035426	1	◆
	Instruction Sheet, Blade Guide Roller Replacement	A04925-364	1	
22	<b>BOLT, BLADE GUIDE ROLLER (RELUBE ONLY)</b>	S08192	1	
23	<b>FITTING, 1/4-28 GREASE (RELUBE ONLY)</b>	P05060	1	

<sup>1</sup> Complete Blade Guide Assembly now supplied with non-greasable sealed bearings. See optional relube parts for greasable blade guide roller parts.

<sup>2</sup> Bearing must be modified for use with relube roller assemblies. Remove one seal from each bearing, place open sides facing each other and place spacer 035411 between bearings.



## 2.2 Blade Guide Assembly, Idle Side

LT15

Rev. A1.00 - D4.01

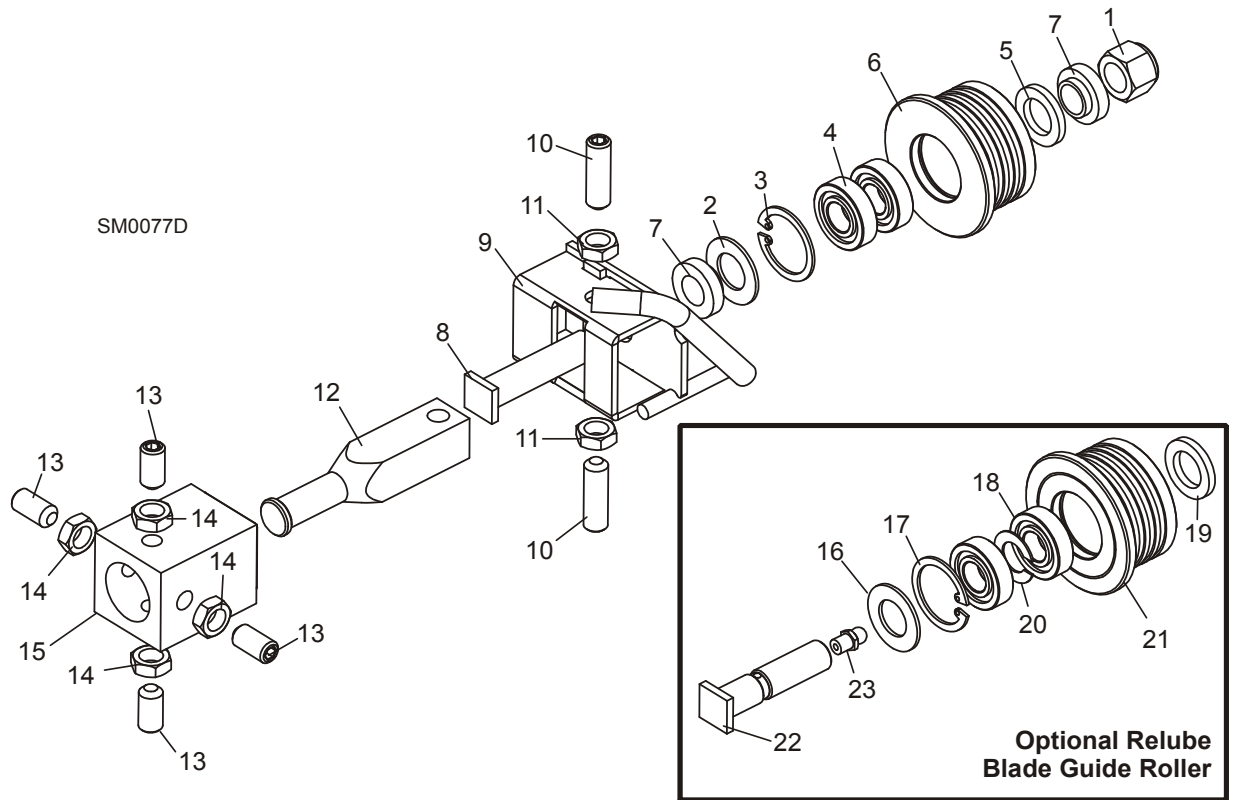

REF	DESCRIPTION (◆ Indicates Parts Available In Assemblies Only)	PART #	QTY.	
	<b>BLADE GUIDE ASSEMBLY, COMPLETE IDLE SIDE</b>	A08197 <sup>1</sup>	1	
1	Nut, 1/2-20 Nylon Hex Lock	F05010-15	1	
	Roller Assembly, Blade Guide	A04925	1	
	Bearing Kit, Blade Guide Rebuild	K07079	1	
2	Washer, 5/8" White Felt	P04252	1	
3	Ring, 1 1/8" Interior Retaining	F04254-1	1	
4	Bearing, R8-2RS Blade Guide	015975	2	◆
5	Washer, 5/8" Gray Felt	P06455	1	
	Screw, 1/4-28 x 1/4" Socket Head Cup Point Set Black Oxide	F05005-105	1	
	Instruction Sheet, Blade Guide Rebuild	057407-1507	1	
6	Roller, Flanged Blade Guide	S04250	1	◆
	Instruction Sheet, Blade Guide Roller Replacement	A04925-364	1	
7	Spacer, Blade Guide	S04253	2	
8	Bolt, Blade Guide Roller	036373	1	
9	Bracket, Blade Guide Idle Side With Water Tube	W08495	1	

## 2

**Blade Guide Rollers & Arm***Blade Guide Assembly, Idle Side*

10	Screw, 3/8-24 X 1 1/4" Stainless Steel Socket Head Flat Point	F05007-96	2	
11	Nut, 3/8-24 Jam	F05010-22	2	
12	Shaft, Blade Guide Adjustment	S08196	1	
13	<b>SCREW, 3/8-24 X 3/4" STAINLESS STEEL SOCKET HEAD FLAT POINT</b>	F05007-95	4	
14	<b>NUT, 3/8-24 JAM</b>	F05010-22	4	
15	<b>TUBE, BLADE GUIDE MOUNT</b> ( <a href="#">See Section 2.5</a> )	W08159	1	
	<b>ROLLER ASSEMBLY, BLADE GUIDE RELUBE (OPTIONAL)</b>	016568	1	
	Bearing Kit, Relube Blade Guide Rebuild	057407	1	
16	Washer, 5/8" White Felt	P04252	1	
17	Ring, 1 1/8" Interior Retaining	F04254-1	1	
18	Bearing, R8-2RS Blade Guide	015975 <sup>2</sup>	2	◆
19	Washer, 5/8" Gray Felt	P06455	1	
20	Spacer, Blade Guide Bearing	035411	1	
	Instruction Sheet, Blade Guide Rebuild	057407-1507	1	
21	Roller, Flanged Blade Guide (Relube)	035426	1	◆
	Instruction Sheet, Blade Guide Roller Replacement	A04925-364	1	
22	<b>BOLT, BLADE GUIDE ROLLER (RELUBE ONLY)</b>	S08192	1	
23	<b>FITTING, 1/4-28 GREASE (RELUBE ONLY)</b>	P05060	1	

<sup>1</sup> Complete blade guide assembly A08197 includes roller with non-greaseable bearings A04925. See optional parts for Relube guide assemblies.

<sup>2</sup> Bearing must be modified for use with relube roller assemblies. Remove one seal from each bearing, place open sides facing each other and place spacer 035411 between bearings.

## 2.3 Blade Guide Assembly, Drive Side

LT15

Rev. D5.00 - E3.02

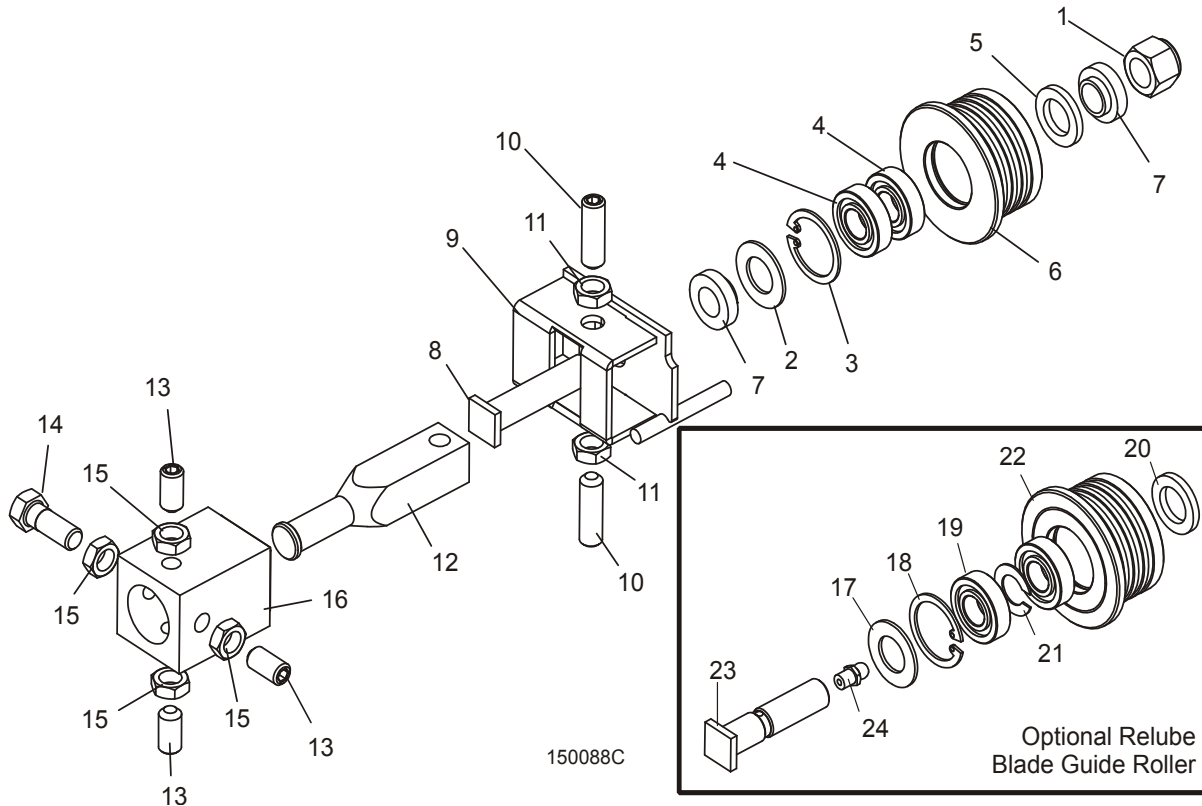

REF	DESCRIPTION (◆ Indicates Parts Available In Assemblies Only)	PART #	QTY.
	<b>BLADE GUIDE ASSEMBLY, COMPLETE DRIVE SIDE</b>	A08191 <sup>1</sup>	1
1	Nut, 1/2-20 Hex Nylon Lock	F05010-15	1
	Roller Assembly, Blade Guide (standard)	A04925	1
	Bearing Kit, Blade Guide Rebuild	K07079	1
2	Washer, 5/8" White Felt	P04252	1
3	Ring, 1 1/8" Interior Retaining	F04254-1	1
4	Bearing, R8-2RS Blade Guide	015975	2
5	Washer, 5/8" Gray Felt	P06455	1
	Screw, 1/4-28 x 1/4" Socket Head Cup Point Set Black Oxide	F05005-105	1
	Instruction Sheet, Blade Guide Rebuild	057407-1507	1
6	Roller, Flanged Blade Guide	S04250	1
	Instruction Sheet, Blade Guide Roller Replacement	A04925-364	1
7	Spacer, Blade Guide	S04253	2
8	Bolt, Blade Guide Roller	036373	1
9	Bracket, Blade Guide Drive Side	W08482	1
10	Screw, 3/8-24 X 1 1/4" Stainless Steel Socket Head Flat Point	F05007-96	2

# 2

## Blade Guide Rollers & Arm

### Blade Guide Assembly, Drive Side

11	Nut, 3/8-24 Jam	F05010-22	2	
12	Shaft, Blade Guide Adjustment	S08196	1	
13	<b>SCREW, 3/8-24 X 3/4" STAINLESS STEEL SOCKET HEAD FLAT POINT SET</b>	F05007-95	3	
14	<b>BOLT, 3/8-24 X 1" STAINLESS STEEL HEX HEAD</b>	F05007-99	1	
15	<b>NUT, 3/8-24 JAM</b>	F05010-22	4	
16	<b>TUBE WELDMENT, BLADE GUIDE MOUNT</b> (Part of saw frame weldment)	W08159	1	
	<b>ROLLER ASSEMBLY, BLADE GUIDE RELUBE (OPTIONAL)</b>	016568	1	
	Bearing Kit, Relube Blade Guide Rebuild	057407	1	
17	Washer, 5/8" White Felt	P04252	1	
18	Ring, 1 1/8" Interior Retaining	F04254-1	1	
19	Bearing, R8-2RS Blade Guide	015975 <sup>2</sup>	2	◆
20	Washer, 5/8" Gray Felt	P06455	1	
21	Spacer, Blade Guide Bearing	035411	1	
	Instruction Sheet, Blade Guide Rebuild	057407-1507	1	
22	Roller, Flanged Blade Guide Relube	035426	1	◆
	Instruction Sheet, Blade Guide Roller Replacement	A04925-364	1	
23	<b>BOLT, BLADE GUIDE ROLLER (RELUBE ONLY)</b>	S08192	1	
24	<b>FITTING, 1/4-28 GREASE (RELUBE ONLY)</b>	P05060	1	

<sup>1</sup> Complete Blade Guide Assembly now supplied with non-greasable sealed bearings. See optional relube parts for greasable blade guide roller parts.

<sup>2</sup> Bearing must be modified for use with relube roller assemblies. Remove one seal from each bearing, place open sides facing each other and place spacer 035411 between bearings.

## 2.4 Blade Guide Assembly, Drive Side

LT15

Rev. A1.00 - D4.01

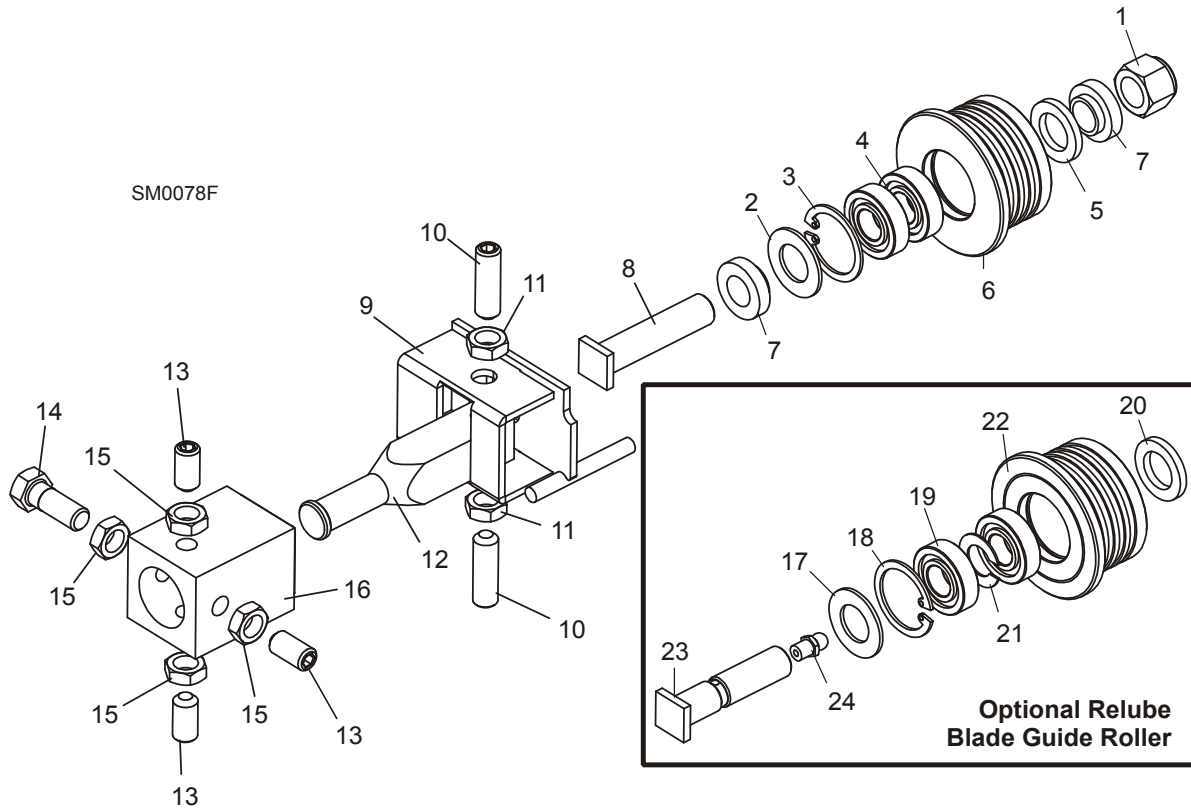

REF	DESCRIPTION (◆ Indicates Parts Available In Assemblies Only)	PART #	QTY.
	<b>BLADE GUIDE ASSEMBLY, COMPLETE DRIVE SIDE</b>	A08191 <sup>1</sup>	1
1	Nut, 1/2-20 Hex Nylon Lock	F05010-15	1
	Roller Assembly, Blade Guide	A04925	1
	Bearing Kit, Blade Guide Rebuild	K07079	1
2	Washer, 5/8" White Felt	P04252	1
3	Ring, 1 1/8" Interior Retaining	F04254-1	1
4	Bearing, R8-2RS Blade Guide	015975	2
5	Washer, 5/8" Gray Felt	P06455	1
	Screw, 1/4-28 x 1/4" Socket Head Cup Point Set Black Oxide	F05005-105	1
	Instruction Sheet, Blade Guide Rebuild	057407-1507	1
6	Roller, Flanged Blade Guide	S04250	1
	Instruction Sheet, Blade Guide Roller Replacement	A04925-364	1
7	Spacer, Blade Guide	S04253	2
8	Bolt, Blade Guide Roller	036373	1

# 2

## Blade Guide Rollers & Arm

### Blade Guide Assembly, Drive Side

9	Bracket, Blade Guide Drive Side	W08482	1	
10	Screw, 3/8-24 X 1 1/4" Stainless Steel Socket Head Flat Point	F05007-96	2	
11	Nut, 3/8-24 Jam	F05010-22	2	
12	Shaft, Blade Guide Adjustment	S08196	1	
13	<b>SCREW, 3/8-24 X 3/4" STAINLESS STEEL SOCKET HEAD FLAT POINT SET</b>	F05007-95	3	
14	<b>BOLT, 3/8-24 X 1" STAINLESS STEEL HEX HEAD</b>	F05007-99	1	
15	<b>NUT, 3/8-24 JAM</b>	F05010-22	4	
16	<b>TUBE WELDMENT, BLADE GUIDE MOUNT</b> (Part of saw frame weldment)	W08159	1	
	<b>ROLLER ASSEMBLY, BLADE GUIDE RELUBE (OPTIONAL)</b>	016568	1	
	Bearing Kit, Relube Blade Guide Rebuild	057407	1	
17	Washer, 5/8" White Felt	P04252	1	
18	Ring, 1 1/8" Interior Retaining	F04254-1	1	
19	Bearing, R8-2RS Blade Guide	015975 <sup>2</sup>	2	◆
20	Washer, 5/8" Gray Felt	P06455	1	
21	Spacer, Blade Guide Bearing	035411	1	
	Instruction Sheet, Blade Guide Rebuild	057407-1507	1	
22	Roller, Flanged Blade Guide (Relube)	035426	1	◆
	Instruction Sheet, Blade Guide Roller Replacement	A04925-364	1	
23	<b>BOLT, BLADE GUIDE ROLLER (RELUBE ONLY)</b>	S08192	1	
24	<b>FITTING, 1/4-28 GREASE (RELUBE ONLY)</b>	P05060	1	

<sup>1</sup> Complete blade guide assembly A08191 includes roller with non-greaseable bearings A04925. See optional parts for Relube guide assemblies.

<sup>2</sup> Bearing must be modified for use with relube roller assemblies. Remove one seal from each bearing, place open sides facing each other and place spacer 035411 between bearings.

## 2.5 Blade Guide Arm

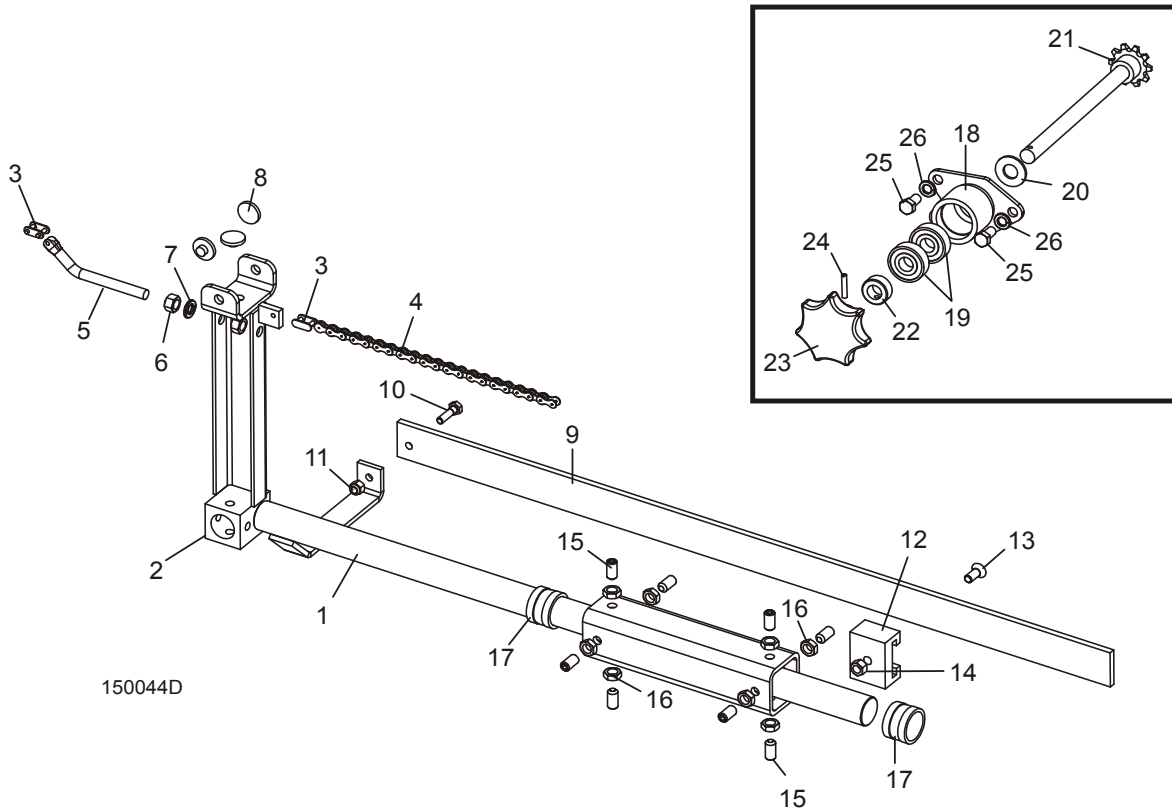

REF	DESCRIPTION (◆ Indicates Parts Available In Assemblies Only)	PART #	QTY.	
1	ARM WELDMENT, LT15 BLADE GUIDE	015800	1	
2	Tube, Blade Guide Mount	W08159	1	
3	LINK, #41 MASTER	P04176	2	
4	CHAIN, #41 X 96"	014830	1	
5	ROD, THREADED BLADE GUIDE ARM CHAIN TENSIONER	014963 <sup>1</sup>	1	◆
6	NUT, 3/8-16 HEX	F05010-1	2	
7	WASHER, 3/8" SPLIT LOCK	F05011-4	1	
8	PAD, BLADE GUIDE SLIDE	014973	3	
9	GUARD, LT15 BLADE GUIDE ARM	014955	1	
10	BOLT, 1/4-20 X 1" HEX HEAD GRADE 2	F05005-38	1	
11	NUT, 1/4-20 HEX NYLON LOCK	F05010-69	1	
12	BLOCK, BLADE GUIDE ARM GUARD GUIDE	014882	1	
13	BOLT, 5/16-18 X 1" FLAT HEAD	F05006-124 <sup>2</sup>	1	
14	NUT, 5/16-18 HEX LOCK	F05010-6	1	
15	SCREW, 3/8-24 X 3/4" FLAT POINT SOCKET HEAD	F05007-95	8	
16	NUT, 3/8"-24 HEX JAM	F05010-22	8	

## 2

**Blade Guide Rollers & Arm***Blade Guide Arm*

17	<b>BUSHING, BLADE GUIDE ARM</b>	015899	2	
	<b>HUB ASSEMBLY, BLADE GUIDE ARM KNOB</b>	014994	1	
18	Hub Weldment, Blade Guide Arm Knob	014980	1	
19	Bearing, 5/8" x 1.75" x .50"	P06030-1	2	
20	Washer, 5/8" SAE Flat	F05011-5	1	
21	Shaft Weldment, Blade Guide Arm Sprocket	014987	1	
22	Collar, 5/8" ID Lock	P05035	1	
23	<b>KNOB, LT15 BLADE GUIDE ARM</b>	036299 <sup>3</sup>	1	
24	<b>PIN, 3/16" X 1" ROLL</b>	F05012-11 <sup>3</sup>	1	
25	<b>BOLT, 3/8-16 X 1" HEX HEAD</b>	F05007-7	3	
26	<b>WASHER, 3/16" SPLIT LOCK</b>	F05011-4	3	

<sup>1</sup> Part no longer available for sale. Contact Customer Service for print, if needed.

<sup>2</sup> 1" bolt F05006-124 replaces 3/4" bolt F05006-95 to improve thread engagement (Rev. E3.01).

<sup>3</sup> Knob 036299 replaces 014999 knob originally supplied prior to Rev. E3.01 to improve ergonomics. New knob requires shorter roll pin F05012-11 (replaces F05012-16).



## SECTION 3 BLADE WHEELS & TENSIONER

### 3.1 Blade Drive Assembly

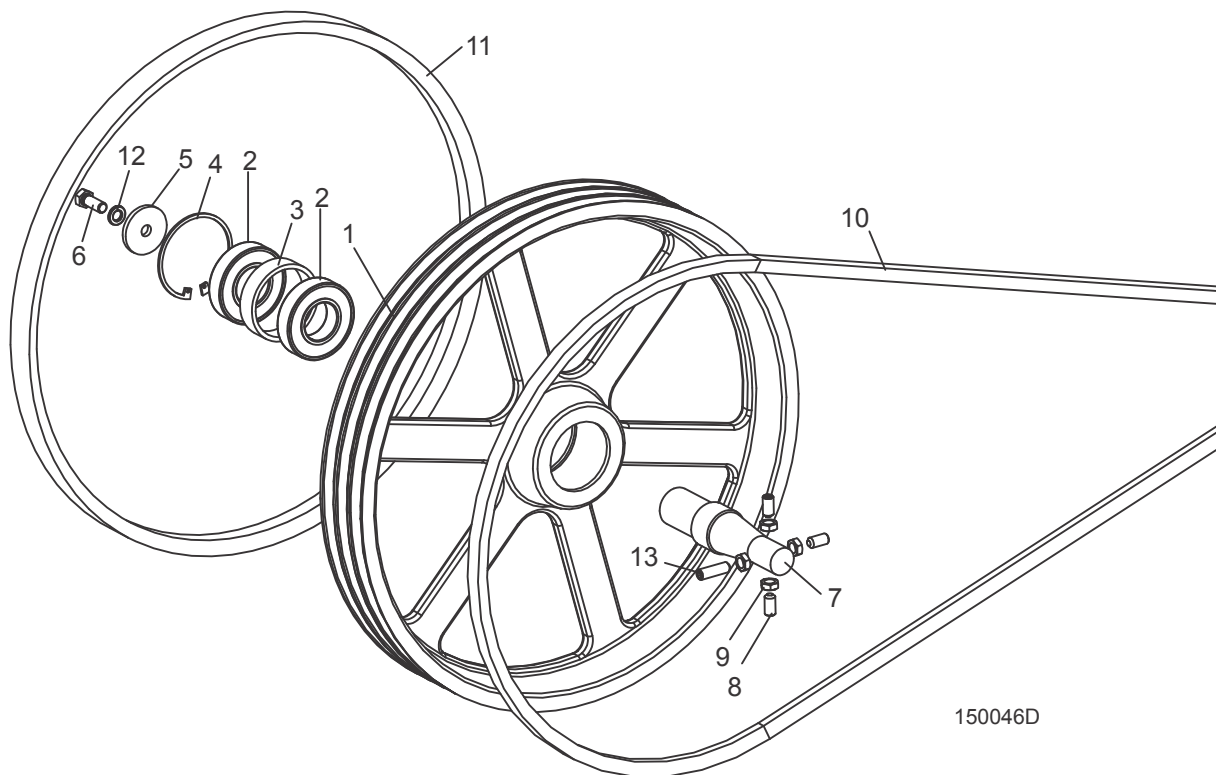

150046D

REF	DESCRIPTION (◆ Indicates Parts Available In Assemblies Only)	PART #	QTY.	
	<b>BLADE WHEEL BRAKE PARTS, D10</b> ( <a href="#">See Engine Manual</a> )			
	<b>BLADE WHEEL BRAKE PARTS, E10</b> ( <a href="#">See Engine Manual</a> )			
	<b>BLADE WHEEL BRAKE PARTS, G13</b> ( <a href="#">See Engine Manual</a> )			
	<b>BLADE WHEEL BRAKE PARTS, G15</b> ( <a href="#">See Engine Manual</a> )			
	<b>WHEEL ASSEMBLY, DRIVE SIDE BLADE</b>	014995	1	
1	Wheel, Drive Side Blade	014727	1	
2	Bearing, #6207 2RS	014811	2	
3	Spacer, Drive Bearing	014730	1	
4	Ring, 3.121 IR Beveled Retaining	F04254-30	1	
5	<b>WASHER, DRIVE WHEEL RETAINING</b>	014728	1	
6	<b>BOLT, 3/8-16 X 1\"</b>	F05007-52	1	
7	<b>SHAFT, LT15 DRIVE SIDE BLADE WHEEL</b>	014729	1	
8	<b>SCREW, 3/8-24 X 3/4\"</b>	F05007-95	4	
9	<b>NUT, 3/8-24 HEX JAM</b>	F05010-22	4	

**3****Blade Wheel & Tensioner***Blade Drive Assembly*

---

<b>10</b>	<b>BELT, BX85 (E10 ONLY)</b>	P25301 <sup>1</sup>	1	
	<b>BELT, BX87 (G13, G15 &amp; D10 ONLY)</b>	017943 <sup>1</sup>	1	
	<b>BELT, BX82</b>	016505 <sup>1</sup>	1	
	<b>BELT, BX81</b>	014819 <sup>1</sup>	1	
<b>11</b>	<b>BELT, B57</b>	P04185	1	
<b>12</b>	<b>WASHER, 3/8" SPLIT LOCK</b>	F05011-4	1	
<b>13</b>	<b>SCREW, 3/8-24 X 1 1/4" FLAT POINT SOCKET HEAD</b>	F05007-96	1	

<sup>1</sup> Use P25301 BX85 belt for Rev. E2.00 electric option. Use 017943 BX87 belt for Rev. E1.00 gas and diesel options. Use 016505 BX82 belt for Rev. D4.00 - D7.00 with pivot-style clutch engagement. Use 014819 BX81 belt for previous models with mechanical clutch/brake assembly on engine.

### 3.2 Idle Blade Wheel Assembly

LT15

Rev. C.00 - E3.02

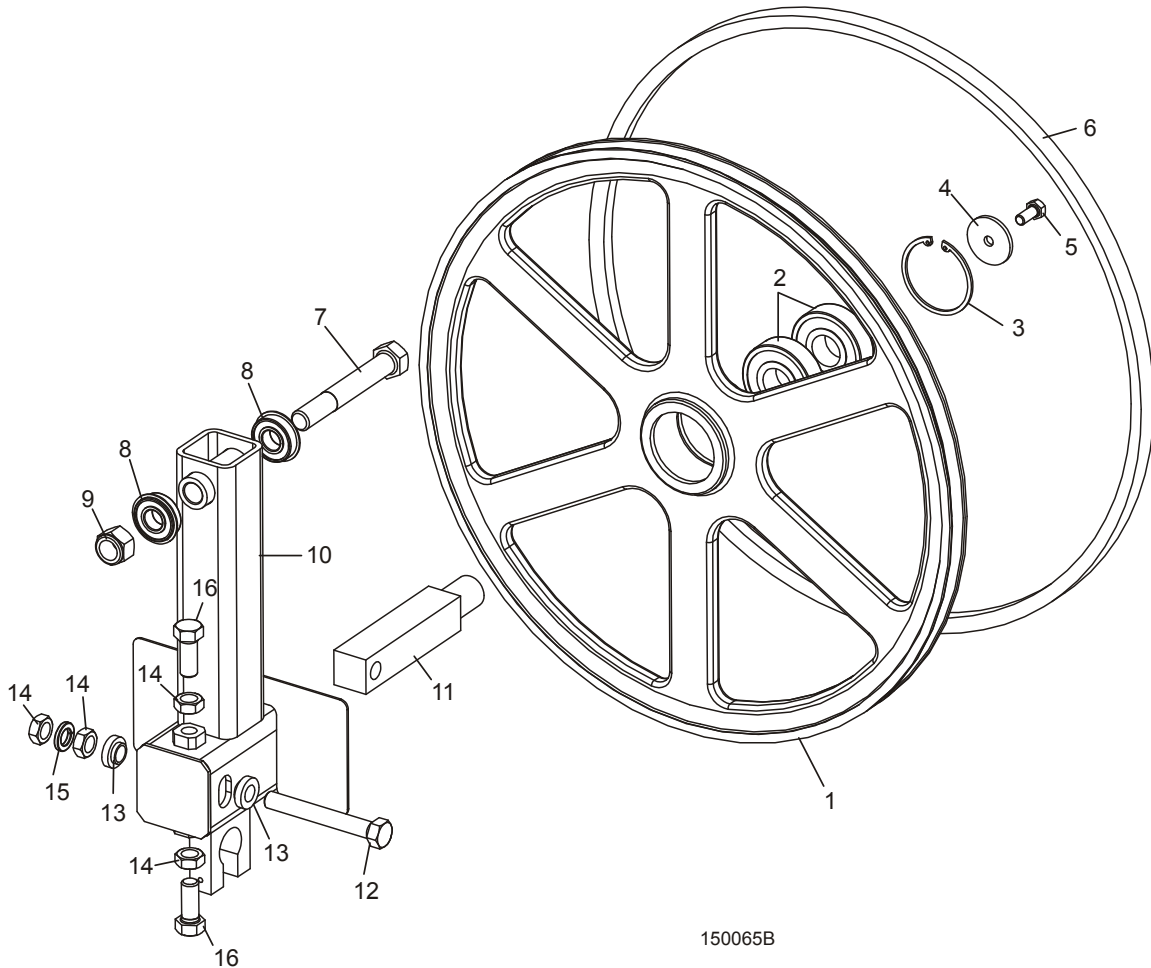

150065B

REF	DESCRIPTION (◆ Indicates Parts Available In Assemblies Only)	PART #	QTY.	
	<b>WHEEL ASSEMBLY, IDLE SIDE BLADE</b>	A08218	1	
1	Wheel, Idle Side Blade	P08125	1	◆
2	Bearing, Idle Side Blade Wheel #6305-AA, C3, ABEC-1, SRI-2 Grease	P08066	2	
3	Ring, 2 7/16" Internal Retaining	F04254-21	1	
4	<b>WASHER, IDLE BLADE WHEEL RETAINER</b>	S08220	1	
5	<b>BOLT, 5/16-18 X 3/4" HEX HEAD</b>	F05006-5	1	
6	<b>BELT, BLADE WHEEL B57</b>	P04185	1	
7	<b>BOLT, 5/8-11 X 4 1/2" HEX HEAD</b>	F05009-3	1	
8	<b>BEARING, 5/8" I.D. W/SNAP RING</b>	014834	2	
9	<b>NUT, 5/8-11 HEX NYLON LOCK</b>	F05010-34	1	
10	<b>HOUSING WELDMENT, IDLER SHAFT</b>	016174	1	
11	<b>SHAFT, IDLE WHEEL</b>	S12565	1	

**3****Blade Wheels & Tensioner***Idle Blade Wheel Assembly*

---

12	<b>BOLT, 1/2-20 X 3 3/4" HEX HEAD FULL THREAD GRADE 2</b>	F05008-111	1	
13	<b>SPACER, 1/2" I.D. FLANGED</b>	S04253	2	
14	<b>NUT, 1/2-20 HEX JAM</b>	F05010-16	4	
15	<b>WASHER, 1/2" SPLIT LOCK</b>	F05011-9	1	
16	<b>BOLT, 1/2-20 X 1 1/4" HEX HEAD GRADE 5</b>	F05008-108 <sup>1</sup>	2	

<sup>1</sup> Replaces 1/2-20 x 1 1/4" Flat Point Set Screw (F05008-109) supplied prior to D4.00.

### 3.3 Idle Blade Wheel Assembly

LT15HA

Rev. A.00 - B.00

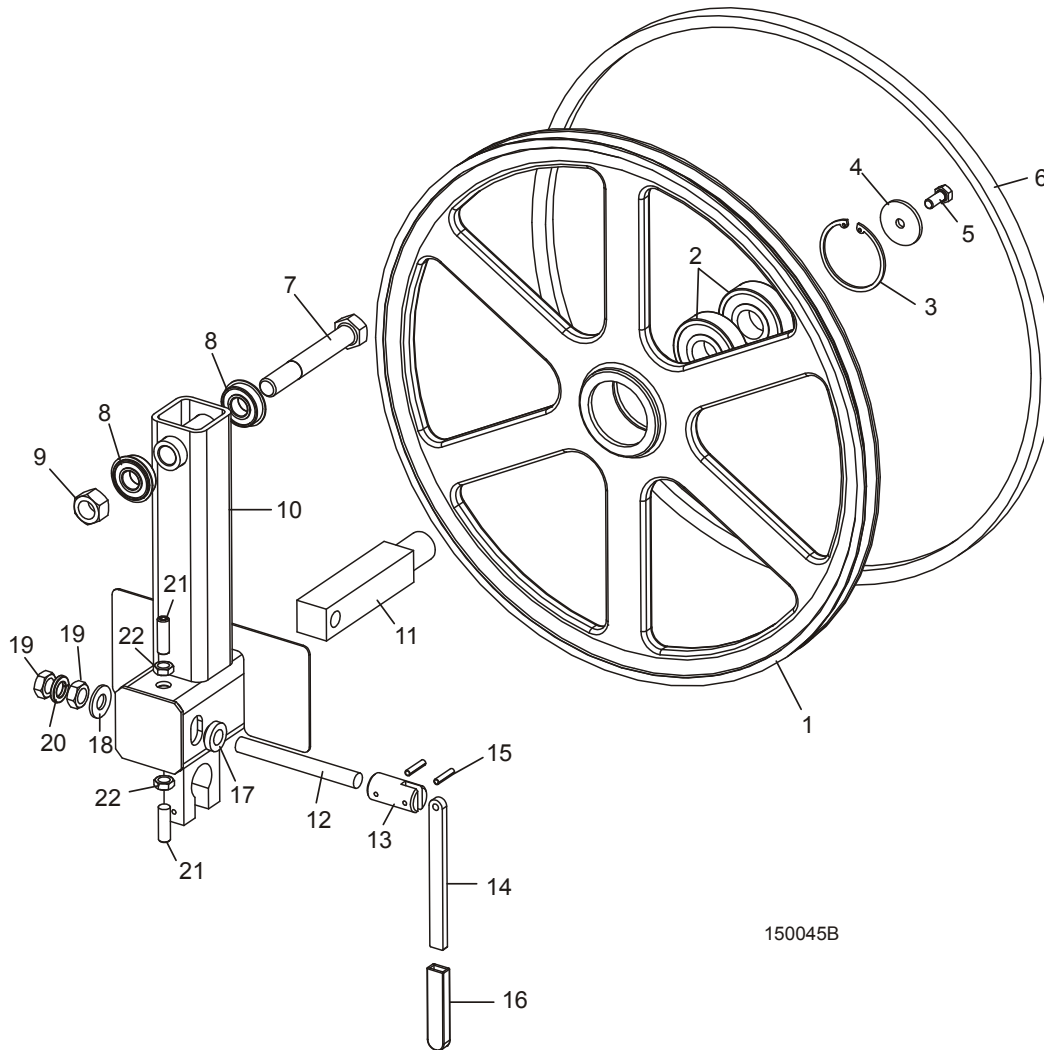

REF	DESCRIPTION (◆ Indicates Parts Available In Assemblies Only)	PART #	QTY.	
	<b>WHEEL ASSEMBLY, IDLE SIDE BLADE</b>	A08218	1	
1	Wheel, Idle Side Blade	P08125	1	◆
2	Bearing, Idle Side Blade Wheel #6305-AA, C3, ABEC-1, SRI-2 Grease	P08066	2	
3	Ring, 2 7/16" Internal Retaining	F04254-21	1	
4	<b>WASHER, IDLE BLADE WHEEL RETAINER</b>	S08220	1	
5	<b>BOLT, 5/16-18 X 3/4" HEX HEAD</b>	F05006-5	1	
6	<b>BELT, BLADE WHEEL B57</b>	P04185	1	
7	<b>BOLT, 5/8-11 X 4 1/2" HEX HEAD</b>	F05009-3	1	
8	<b>BEARING, 5/8" I.D. W/SNAP RING</b>	014834	2	
9	<b>NUT, 5/8-11 HEX NYLON LOCK</b>	F05010-34	1	

## 3

**Blade Wheels & Tensioner***Idle Blade Wheel Assembly*

10	<b>HOUSING WELDMENT, IDLER SHAFT</b>	014986	1	
11	<b>SHAFT, IDLE WHEEL</b>	S12565	1	
	<b>HANDLE ASSEMBLY, IDLE WHEEL ADJUSTMENT</b>	A09357	1	
12	Rod, Threaded Tilt Adjustment Screw	S09358	1	◆
13	Driver, Tilt Adjustment Screw	S09405	1	◆
14	Handle, Tilt Adjustment Screw	S08174	1	◆
15	Pin, 3/16" x 7/8" Roll	F05012-19	2	
16	<b>SLEEVE, PLASTIC HANDLE</b>	P08072	1	
17	<b>SPACER, 1/2" I.D. FLANGED</b>	S04253	2	
18	<b>WASHER, 1/2" SAE FLAT</b>	F05011-2	1	
19	<b>NUT, 1/2-20 HEX JAM</b>	F05010-16	2	
20	<b>WASHER, 1/2" SPLIT LOCK</b>	F05011-9	1	
21	<b>SCREW, 3/8-16 X 1 1/4" SOCKET HEAD OVAL POINT</b>	F05007-18	2	
22	<b>NUT, 3/8-16 HEX JAM</b>	F05010-29	2	

### 3.4 Blade Tensioner Assembly

LT15

Rev. E3.01 - E3.02

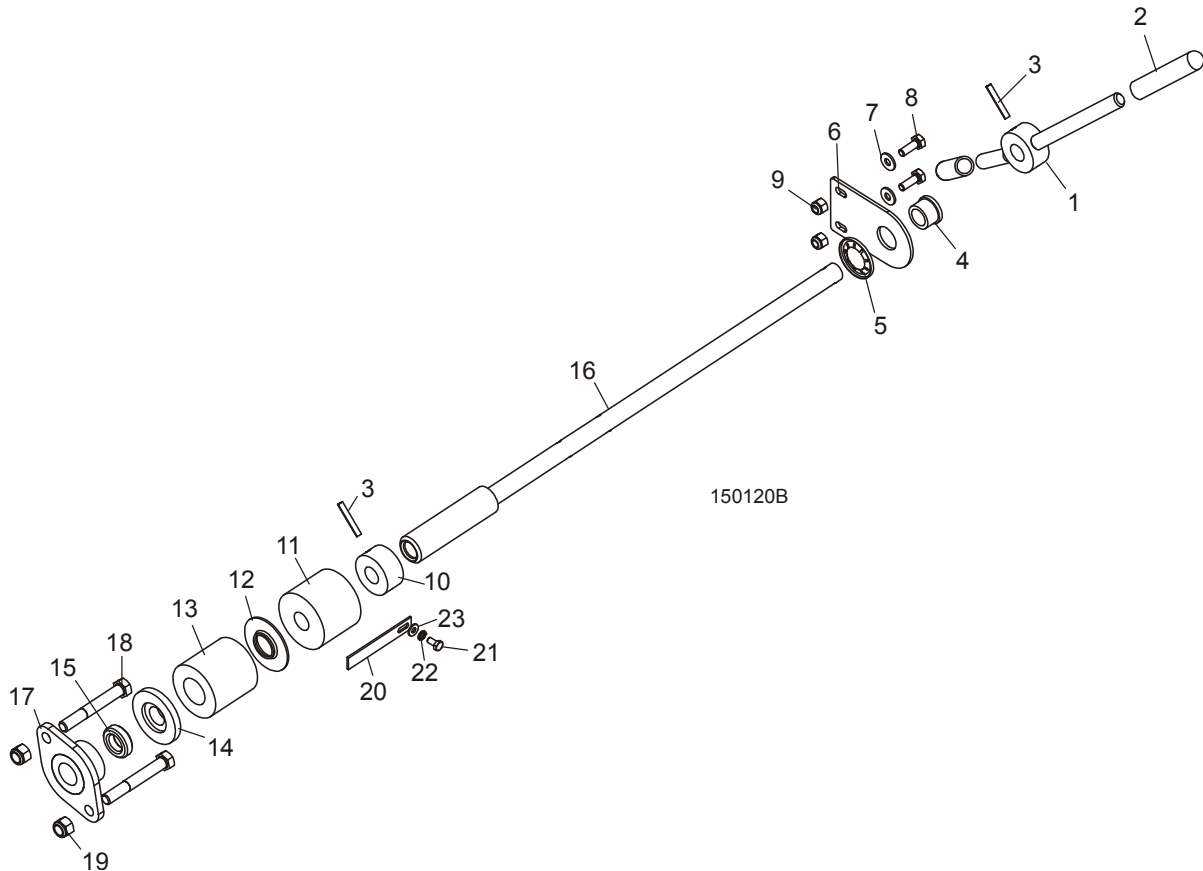

REF	DESCRIPTION (◆ Indicates Parts Available In Assemblies Only)	PART #	QTY.
	<b>HANDLE ASSEMBLY, LT15 BLADE TENSION</b>	015842 <sup>1</sup>	1
1	Handle Weldment, LT15 Blade Tension	014920	1
2	Grip, 1/2" I.D. x 3" Long Handle	014835	2
3	Pin, 3/16" x 1 1/4" Roll	F05012-16	2
4	Bushing, 5/8" x 7/8" x 1/2" Bronze	P05135	1
5	Ring, 7/8" Push Nut	F04254-31	1
6	Bracket, Tension Handle Mount	036343 <sup>1</sup>	1
7	Bolt, 1/4-20 x 3/4" Hex Head Full Thread	F05005-1 <sup>1</sup>	2
8	Washer, 1/4" SAE Flat	F05011-11 <sup>1</sup>	2
9	Nut, 1/4-20 Hex Nylon Lock	F05010-69	2
10	Collar, LT15 Tension Handle	014921	1
11	Bushing, .68" x 2.25" x 1.75" Rubber	P12165	1
12	Washer, Rubber Spring Rear	014925	1
13	Spring, Rubber Blade Tension	014828	1

**3****Blade Wheels & Tensioner***Blade Tensioner Assembly*

14	Washer, Rubber Spring Front	015839	1	
15	Bearing, 5/8" Thrust	P04214	1	
16	Shaft Weldment, LT15 Tension Handle	014846	1	
17	Nut Weldment, LT15 Tension Handle	014991	1	
18	Bolt, 3/8-16 x 2 3/4" Hex Head	F05007-29	2	
19	Nut, 3/8-16 Hex Nylon Lock	F05010-10	2	
20	<b>BRACKET, TENSION INDICATOR</b>	014966	1	
21	<b>SCREW, #10-32 X 1/2" HEX HEAD</b>	F05004-60	1	
22	<b>WASHER, #8 SPLIT LOCK</b>	F05011-41	1	
23	<b>WASHER, #10 SAE FLAT</b>	F05011-20	1	

<sup>1</sup> Tension Handle Assembly 015842 includes new mounting bracket 036343 and hardware to mount bracket to front of C-frame to eliminate possible binding (Rev. E3.01). [See Section 3.5](#) for previous revision parts.



### 3.5 Blade Tensioner Assembly

LT15

Rev. A1.00 - E3.00

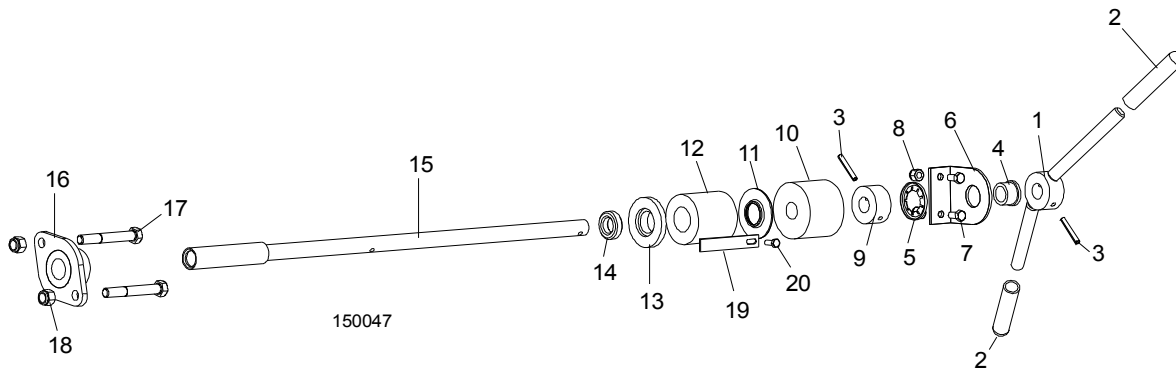

REF	DESCRIPTION (◆ Indicates Parts Available In Assemblies Only)	PART #	QTY.
	<b>HANDLE ASSEMBLY, LT15 BLADE TENSION</b>	015842 <sup>1</sup>	1
1	Handle Weldment, LT15 Blade Tension	014920	1
2	Grip, 1/2" I.D. x 3" Long Handle	014835	2
3	Pin, 3/16" x 1 1/4" Roll	F05012-16	2
4	Bushing, 5/8" x 7/8" x 1/2" Bronze	P05135	1
5	Ring, 7/8" Push Nut	F04254-31	1
6	Bracket, Tension Handle Mount	014926 <sup>1</sup>	1
7	Bolt, 1/4-20 x 1/2" Hex Head	F05005-15 <sup>1</sup>	2
8	Nut, 1/4-20 Hex Nylon Lock	F05010-69	2
9	Collar, LT15 Tension Handle	014921	1
10	Bushing, .68" x 2.25" x 1.75" Rubber	P12165	1
11	Washer, Rubber Spring Rear	014925	1
12	Spring, Rubber Blade Tension	014828	1
13	Washer, Rubber Spring Front	015839	1
14	Bearing, 5/8" Thrust	P04214	1
15	Shaft Weldment, LT15 Tension Handle	014846	1
16	Nut Weldment, LT15 Tension Handle	014991	1
17	Bolt, 3/8-16 x 2 3/4" Hex Head	F05007-29	2
18	Nut, 3/8-16 Hex Nylon Lock	F05010-10	2
19	<b>BRACKET, TENSION INDICATOR</b>	014966	1
20	<b>SCREW, #10-32 X 1/2" HEX HEAD</b>	F05004-60	1

<sup>1</sup> Tension Handle Assembly 015842 includes mounting bracket and hardware for mounting bracket to front of C-Frame ([See Section 3.4](#)).

# 4 Saw Head

## Water Lube Assembly

### SECTION 4 SAW HEAD

#### 4.1 Water Lube Assembly

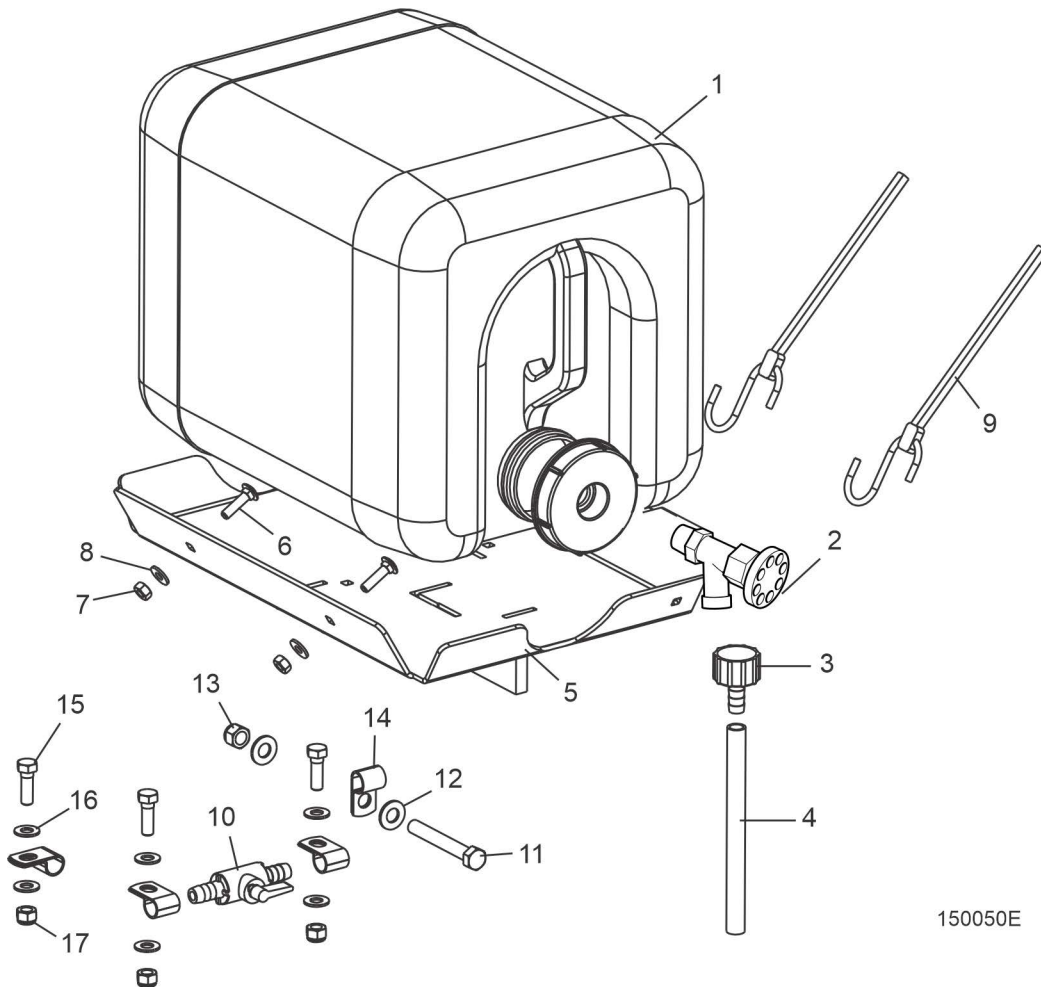

REF	DESCRIPTION (◆ Indicates Parts Available In Assemblies Only)	PART #	QTY.
	<b>WATER LUBE ASSEMBLY</b>	015799	1
1	Bottle Assembly, Water Lube w/Cap	014642 <sup>1</sup>	1
	Fitting, 3/4 FPT x 3/4 MPT	014636	1
2	Valve, 3/4 NPT Elbow 3/4 Male GHT Outlet	133320 <sup>2</sup>	1
	Fitting, Water Lube Shutoff Valve	014100	1
3	Fitting, 5/8" NPT to 3/8" Hose Barb	014113	1
4	Tubing, Water Lube 3/8" I.D.	R01885	12.8 ft.
5	Tray Weldment, LT15 Water Lube	015798	1
6	Bolt, 1/4-20 x 1" Carriage Head	F05005-34	2
7	Nut, 1/4-20 Hex Lock	F05010-21	2
8	Washer, 1/4" SAE Flat	F05011-11	2

<b>9</b>	Strap, 20" Rubber w/Hook	P11668	2	
<b>10</b>	Valve, LT15 Water Shut Off	065635 <sup>3</sup>	1	
<b>11</b>	Bolt, 3/8-16 x 2 3/4" Hex Head Full Thread Grade 5	F05007-230 <sup>4</sup>	1	
<b>12</b>	Washer, 3/8" Flat SAE	F05011-3	2	
<b>13</b>	Nut, 3/8-16 Hex Nylon Lock	F05010-10	1	
<b>14</b>	Clamp, 1/2" EMT Coated	P07584	4	
<b>15</b>	Bolt, 5/16-18 x 1" Hex Head	F05006-1	3	
<b>16</b>	Washer, 5/16" SAE Flat	F05011-17	6	
<b>17</b>	Nut, 5/16-18 Nylok Hex	F05010-58	3	

<sup>1</sup> Use Water Bottle Assembly w/Cap 014642 to service all bottle/cap combinations previously supplied. Bottle 014367, 61mm Cap 014773 and 70mm Cap 036744 no longer available separately.

<sup>2</sup> Replaced 01400 & 014636 after 9/19/2022 per ECN 38718.

<sup>3</sup> Added to make the lube system easier to operate (Rev. E7.00).

<sup>4</sup> F05007-230 replaced F05007-27 3/8-16 x 3/4" Hex Head Bolt. Also, removed F05011-4 3/8" Split Lock Washer and added (1) F05011-3 and (1) F05010-10 (5/12).

# 4 Saw Head

## Saw Head Decals

### 4.2 Saw Head Decals

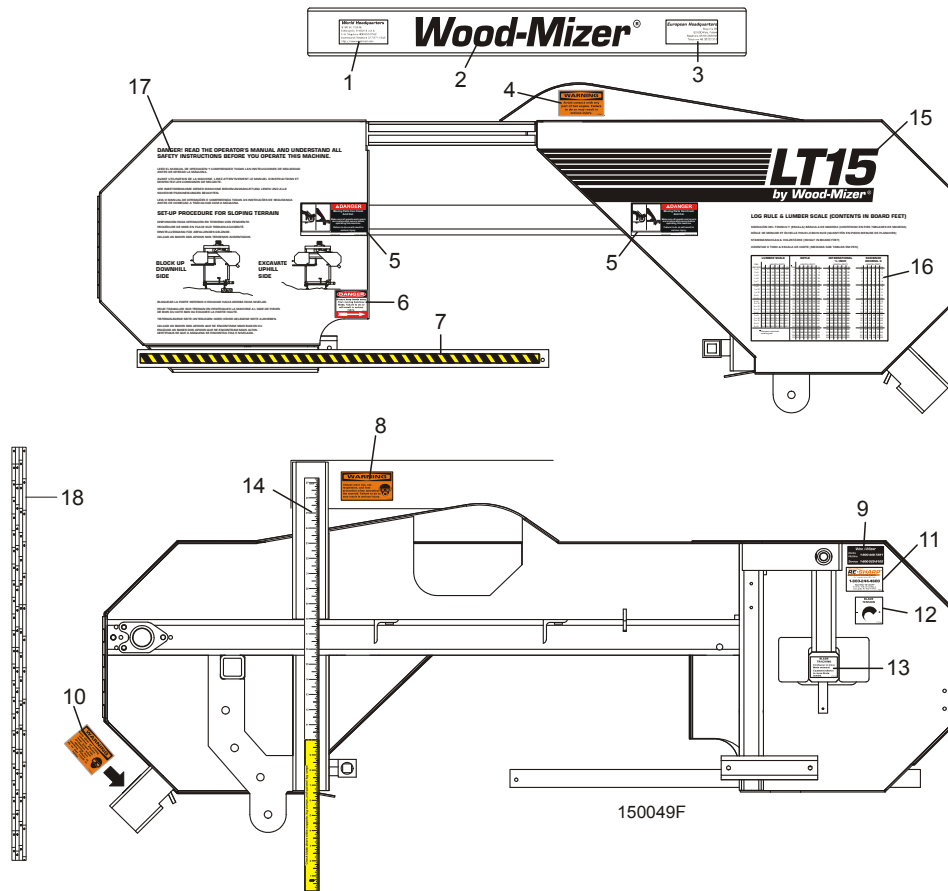

REF	DESCRIPTION (◆ Indicates Parts Available In Assemblies Only)	PART #	QTY.
1	DECAL, WORLD HEADQUARTERS ADDRESS	015840	1
2	DECAL, WOOD-MIZER LOGO	S12281	1
3	DECAL, EUROPEAN HEADQUARTERS ADDRESS	015841	1
4	DECAL, HOT ENGINE WARNING	014419	1
5	DECAL, MOVING PARTS DANGER	033254 <sup>1</sup>	2
6	DECAL, BLADE DANGER W/ARROW	S11752	1
7	DECAL, BLADE GUIDE ARM STRIPE	015849	1
8	DECAL, EYE/EAR PROTECTION WARNING	S11753	1
9	DECAL, TOLL FREE PARTS	S12117	1
10	DECAL, SAWDUST CHUTE WARNING	P11754	1
11	DECAL, TRUSHARP INFO	P12879	1
12	DECAL, BLADE TENSION INFO	P11790	1
13	DECAL, BLADE TRACK INFO	P11789	1
14	DECAL, LT15 INCH SCALE	015784	1
15	DECAL, BLADE HOUSING COVER (DRIVE SIDE - LOGO)	016269	1
16	DECAL, BLADE HOUSING COVER (DRIVE SIDE - LOG SCALE)	016283	1

17	DECAL, BLADE HOUSING COVER (IDLE SIDE)	016268	1	
18	DECAL, MAGNETIC QUARTER SCALE	016275	1	

<sup>1</sup> Replaces S20039 decal originally supplied (5/00).

# 4 Saw Head

## Blade Housing Covers & Wood Blocks

### 4.3 Blade Housing Covers & Wood Blocks

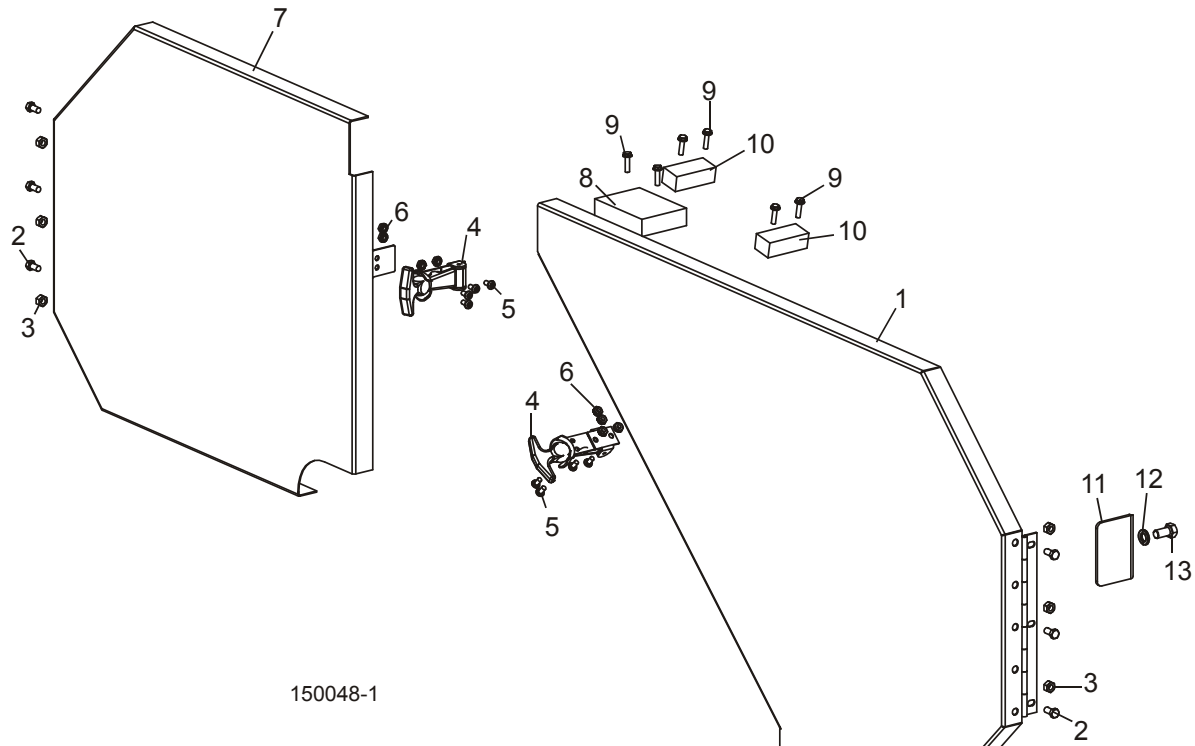

REF	DESCRIPTION (◆ Indicates Parts Available In Assemblies Only)	PART #	QTY.
1	COVER, DRIVE SIDE BLADE HOUSING (Includes Cover Decal - <a href="#">See Section 4.2</a> )	014984	1
2	BOLT, 1/4-20 X 1/2" HEX HEAD	F05005-15	6
3	NUT, 1/4-20 HEX LOCK	F05010-21	6
4	LATCH, FLEXIBLE DRAW	014829	2
5	SCREW, #10-24 X 3/8" CROSS SLOTTED ROUND HEAD	F05004-3	8
6	NUT, #10-24 SELF-LOCKING HEX	F05010-14	8
7	COVER, IDLE SIDE BLADE HOUSING (Includes Cover Decal - <a href="#">See Section 4.2</a> )	014985	1
8	BLOCK, BLADE VIBRATION DAMPENING	015844	1
9	BOLT, #10 X 3/4" SLOTTED HEX WASHER HEAD	F05015-33	6
10	BLOCK, 3/4" X 1" X 2" WOOD	016506 <sup>1</sup>	2
11	COVER, BLADE GUIDE ARM CHAIN ACCESS	014951	1
12	WASHER, 3/8" SPLIT LOCK	F05011-4	1
13	BOLT, 3/8-16 X 3/4" HEX HEAD GRADE 2	F05007-27	1

<sup>1</sup> 016507 3/4" X 1" X 11" wood block (1) and 016506 3/4" X 1" X 2" wood block (1) added LT15 revision D4.00. One more 016506 added to replace 016507 (8/02).

4.4 Battery Box Assembly

LT15

Rev. E2.00 - E3.02

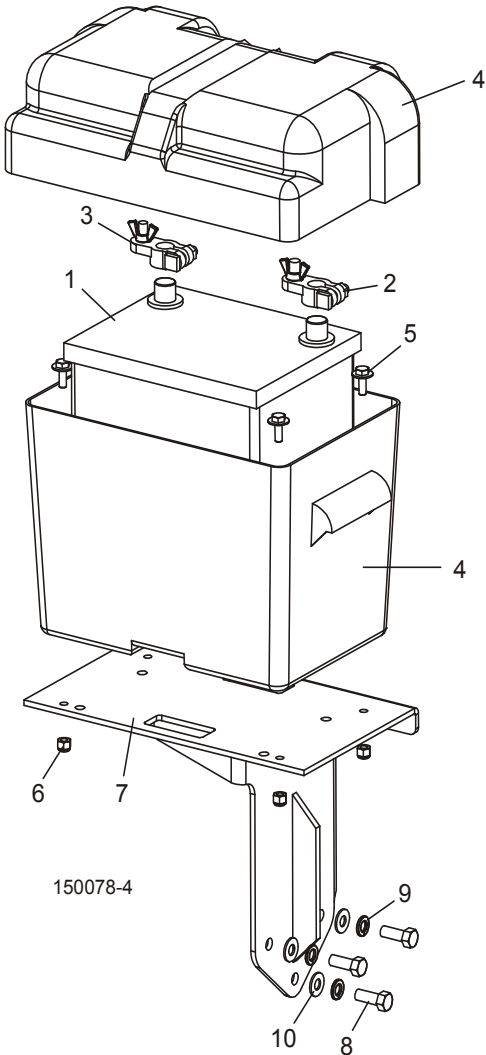

REF	DESCRIPTION (◆ Indicates Parts Available In Assemblies Only)	PART NUMBER	QTY.	
1	BATTERY, 12 VOLT 524/26A	028004	1	◆
2	TERMINAL, POSITIVE BATTERY	033358	1	
3	TERMINAL, NEGATIVE BATTERY	033359	1	
4	BOX ASSEMBLY, LT15 BATTERY	016413	1	
5	BOLT, 1/4-20X3/4 W/CONICAL WASHER	F05005-13	4	
6	NUT, 1/4" NYLON LOCK	F05010-69	4	
7	MOUNT WELDMENT, BATTERY/CONTROL BOX	034899	1	
8	BOLT, 3/8-16X1 HH	F05007-7	3	
9	WASHER, 3/8 SPLIT	F05011-4	3	
10	WASHER, 3/8 FLAT	F05011-3	3	

# 4 Saw Head

## Battery Box Assembly

LT15

Rev. A1.00 - E1.00

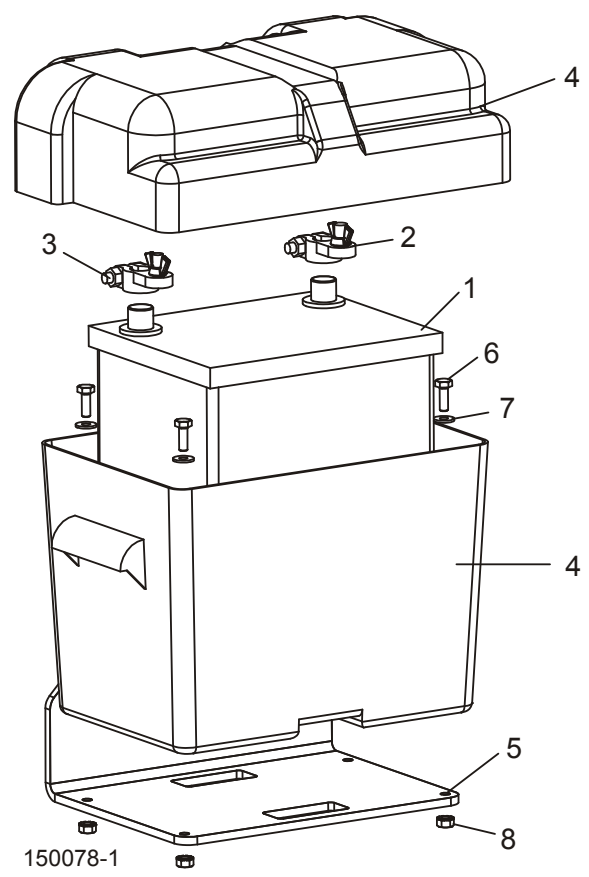

REF	DESCRIPTION (◆ Indicates Parts Available In Assemblies Only)	PART NUMBER	QTY.	
1	BATTERY, 12 VOLT 524/26A	028004	1	◆
2	TERMINAL, POSITIVE BATTERY	033358	1	
3	TERMINAL, NEGATIVE BATTERY	033359	1	
4	BOX ASSEMBLY, LT15 BATTERY	016413	1	
5	PLATE WELDMENT, LT15 BATTERY BOX MOUNT	033363	1	
6	BOLT, 1/4-20 X 3/4" HEX HEAD FULL THREAD	F05005-1	4	
7	WASHER, 1/4" SAE FLAT	F05011-11	4	
8	NUT, 1/4-20 HEX SELF-LOCKING	F05010-9	4	



## SECTION 5 UP/DOWN SYSTEM

### 5.1 Saw Head Mount & Blade Scales

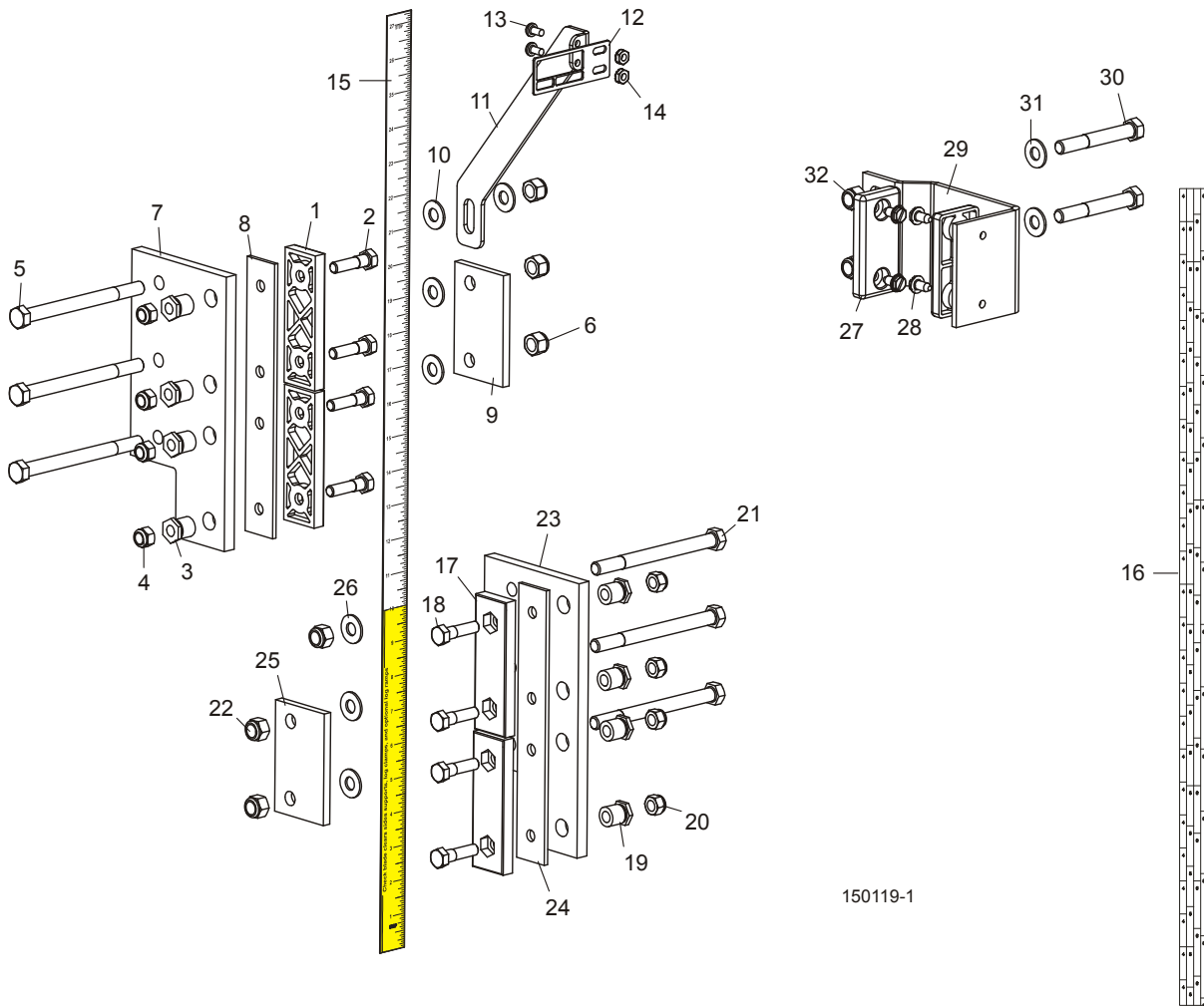

150119-1

REF	DESCRIPTION (◆ Indicates Parts Available In Assemblies Only)	PART #	QTY.
	<b>PAD ASSEMBLY, LT15 UP/DOWN TOP SLIDE</b>	036262	1
1	Pad, Up/Down Slide	M04096	2
2	Bolt, 5/16-18 x 1 1/4" Hex Head Full Thread	F05006-18	4
3	Nut, Slide Pad Adjustment	014931	4
4	Nut, 5/16-18 Hex Nylon Lock	F05010-58	4
5	Bolt, 3/8-16 x 4 1/2" Hex Head	F05007-35	3
6	Nut, 3/8-16 Hex Nylon Lock	F05010-10	3
7	Plate, Slide Pad Mount	014927	1
8	Plate, Slide Pad Backing	014898	1

## 5 Up/Down System

### Saw Head Mount & Blade Scales

9	Plate, Short Slide Pad	014998	1	
10	Washer, 3/8" SAE Flat	F05011-3	4	
11	Bracket, Blade Height Scale Mount	014903	1	
12	Indicator, Blade Height Scale	017778 <sup>1</sup>	1	
13	Screw, #10-24 x 3/8" Cross Slotted Pan Head	F05004-3	2	
14	Nut, #10-24 Hex Self-Retaining	F05010-14	2	
15	<b>DECAL, LT15 INCH SCALE</b>	015784	1	
16	<b>SCALE, LT15 MAGNETIC QUARTER</b>	016275 <sup>2</sup>	1	
	<b>PAD ASSEMBLY, LT15 UP/DOWN BOTTOM SLIDE</b>	036266	1	
17	Pad, Up/Down Slide	M04096	2	
18	Bolt, 5/16-18 x 1 1/4" Hex Head Full Thread	F05006-18	4	
19	Nut, Slide Pad Adjustment	014931	4	
20	Nut, 5/16-18 Hex Nylon Lock	F05010-58	4	
21	Bolt, 3/8-16 x 4 1/2" Hex Head	F05007-35	3	
22	Nut, 3/8-16 Hex Nylon Lock	F05010-10	3	
23	Plate, Slide Pad Mount	014927	1	
24	Plate, Slide Pad Backing	014898	1	
25	Plate, Short Slide Pad	014998	1	
26	Washer, 3/8" SAE Flat	F05011-3	3	
27	<b>PAD, IDLE SIDE SLIDE</b>	P13576	2	
28	<b>BOLT, 1/4-20 X 1/2" SLOTTED HEX HEAD</b>	F05015-1	4	
29	<b>BRACKET, IDLE SIDE SLIDE PAD MOUNT</b>	014905	1	
30	<b>BOLT, 3/8-16 X 2 3/4" HEX HEAD</b>	F05007-29	2	
31	<b>WASHER, 3/8" SAE FLAT</b>	F05011-3	2	
32	<b>NUT, 3/8-16 HEX NYLON LOCK</b>	F05010-10	2	

<sup>1</sup> 017778 replaces M07267-N pointer.

<sup>2</sup> Available 3/99.

## 5.2 Manual Crank Assembly

LT15

Rev. B.00 - E3.02

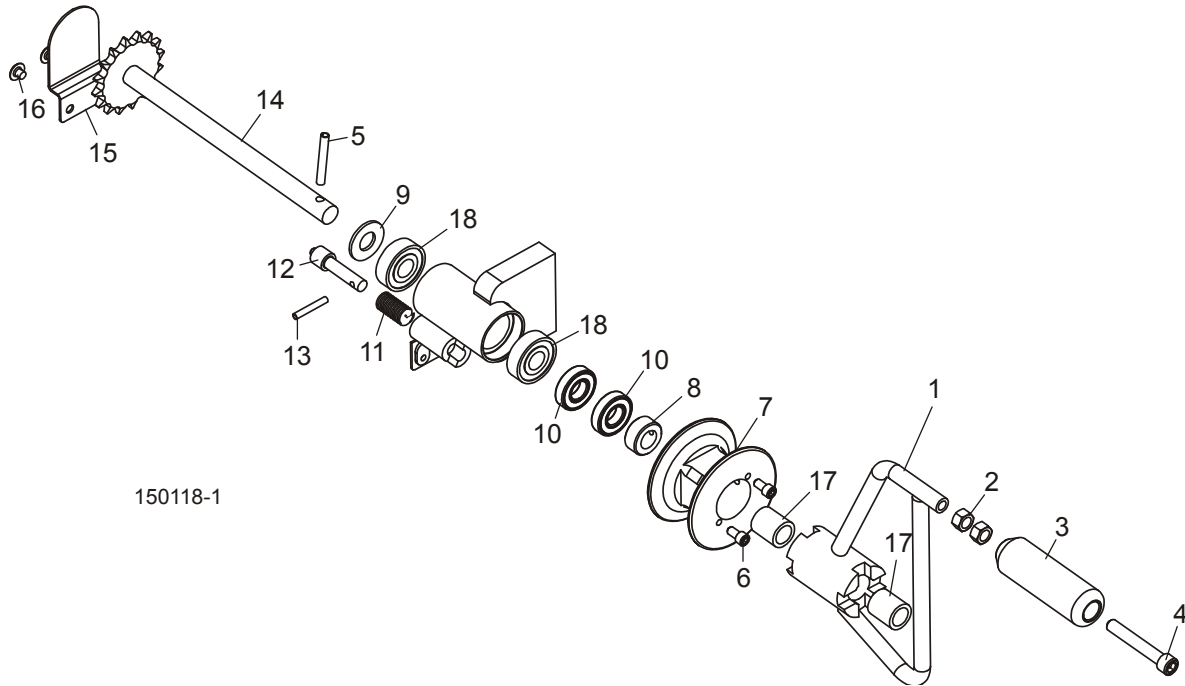

REF	DESCRIPTION (◆ Indicates Parts Available In Assemblies Only)	PART #	QTY.
1	CRANK WELDMENT, LT15 FEED/UP/DOWN	014982	1
2	NUT, 3/8-16 HEX	F05010-1	2
3	KNOB, PLASTIC CRANK HANDLE	S12456	1
4	BOLT, 3/8-16 X 2 1/2" SOCKET HEAD	F05007-24	1
5	PIN, 1/4" X 1 3/4" ROLL	F05012-53	1
6	BOLT, 1/4-20 X 3/4" SOCKET HEAD	F05005-26	2
7	PULLEY, FEED ROPE	014935	1
8	COLLAR, 5/8" I.D. LOCK	P05035	1
9	WASHER, 5/8" SAE FLAT	F05011-5	2
10	BEARING, R-10	P04156	2
11	SPRING, .58 OD X 1 1/8"	021243 <sup>1</sup>	1
12	PIN, LT15 LOCK	016053 <sup>1</sup>	1
13	PIN, 3/16 X 1 1/4" ROLL	F05012-16	1
14	SHAFT WELDMENT, UP/DOWN SPROCKET	014989	1
15	GUARD, UP/DOWN SPROCKET SHAFT	015884	1
16	BOLT, 1/4-20 X 1/4" PHILLIPS PAN HEAD	F05005-133	2
17	BUSHING, 5/8" ID X 7/8" OD X 1" BRONZE	015843	2
18	BEARING, 5/8" ID X 1.7548" OD X .4724	P06030-1	2

<sup>1</sup> Up/Down Lock Pin and Spring modified for Rev. B.00. [See Section 5.3](#) for previous revision.

### 5.3 Manual Crank Assembly

LT15

Rev. A.00 - A.01

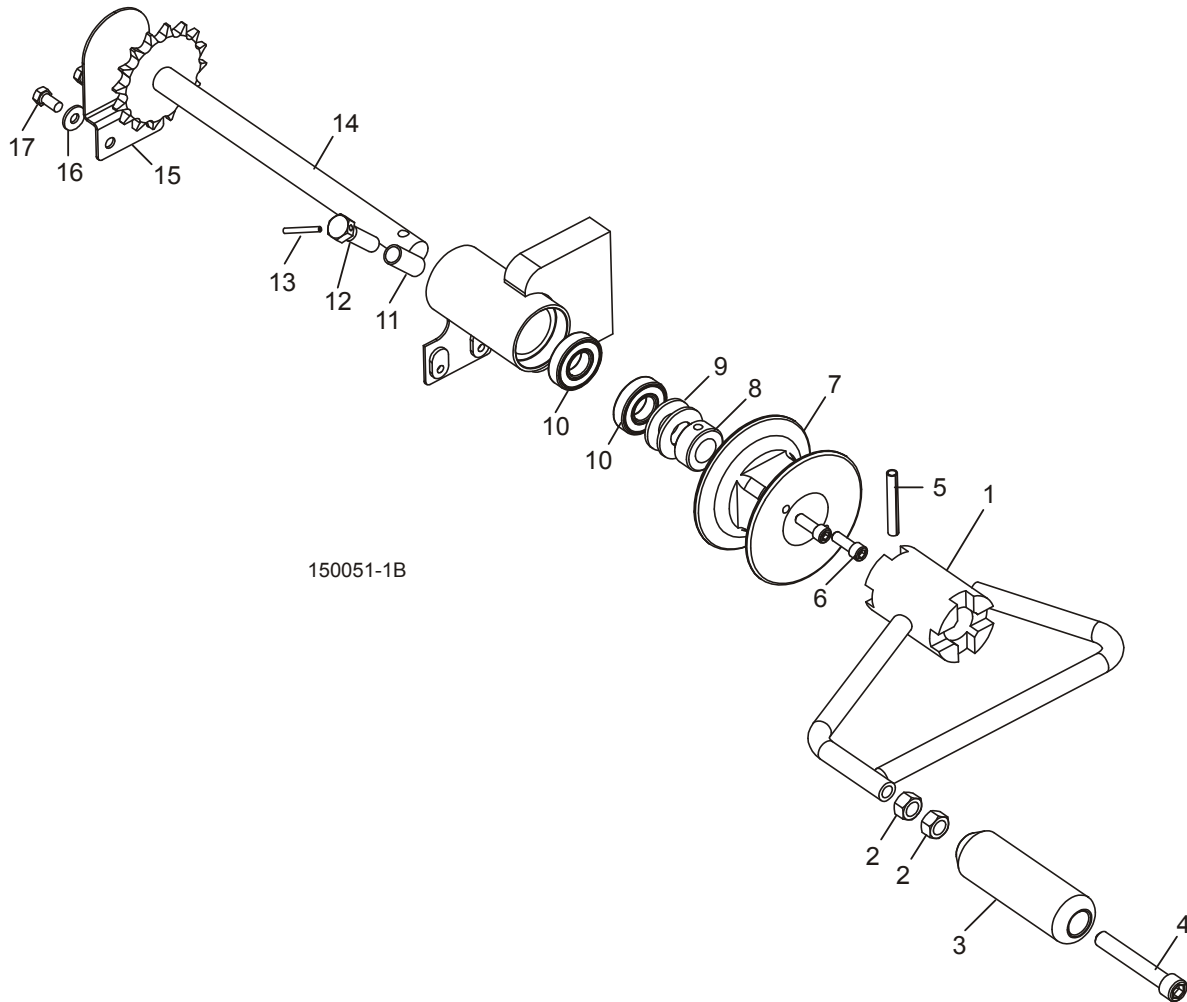

REF	DESCRIPTION (◆ Indicates Parts Available In Assemblies Only)	PART #	QTY.
1	CRANK WELDMENT, LT15 FEED/UP/DOWN	014982	1
2	NUT, 3/8-16 HEX	F05010-1	2
3	KNOB, PLASTIC CRANK HANDLE	S12456	1
4	BOLT, 3/8-16 X 2 1/2" SOCKET HEAD	F05007-24	1
5	PIN, 1/4" X 1 3/4" ROLL	F05012-53	1
6	BOLT, 1/4-20 X 3/4" SOCKET HEAD	F05005-26	2
7	PULLEY, FEED ROPE	014935	1
8	COLLAR, 5/8" I.D. LOCK	P05035	1
9	WASHER, 5/8" SAE FLAT	F05011-5	2
10	BEARING, R-10	P04156	2
11	SPRING, .480" X 1" X .046" COMPRESSION	P12494 <sup>1</sup>	1

	<b>LOCK ASSEMBLY, UP/DOWN</b>	015806 <sup>1</sup>	1	
<b>12</b>	Bolt, Modified Up/Down Lock	015805	1	◆
<b>13</b>	Pin, 1/8" x 1" Roll	F05012-34	1	
<b>14</b>	<b>SHAFT WELDMENT, UP/DOWN SPROCKET</b>	014989	1	
<b>15</b>	<b>GUARD, UP/DOWN SPROCKET SHAFT</b>	015884	1	
<b>16</b>	<b>WASHER, 1/4" SAE FLAT</b>	F05011-11	2	
<b>17</b>	<b>BOLT, 1/4-20 X 1/4" PHILLIPS PAN HEAD</b>	F05005-133	2	

<sup>1</sup> Up/Down Lock Pin and Spring redesigned for Rev. B.00 ([See Section 5.2](#)).

### 5.4 Sprocket Drive Assembly

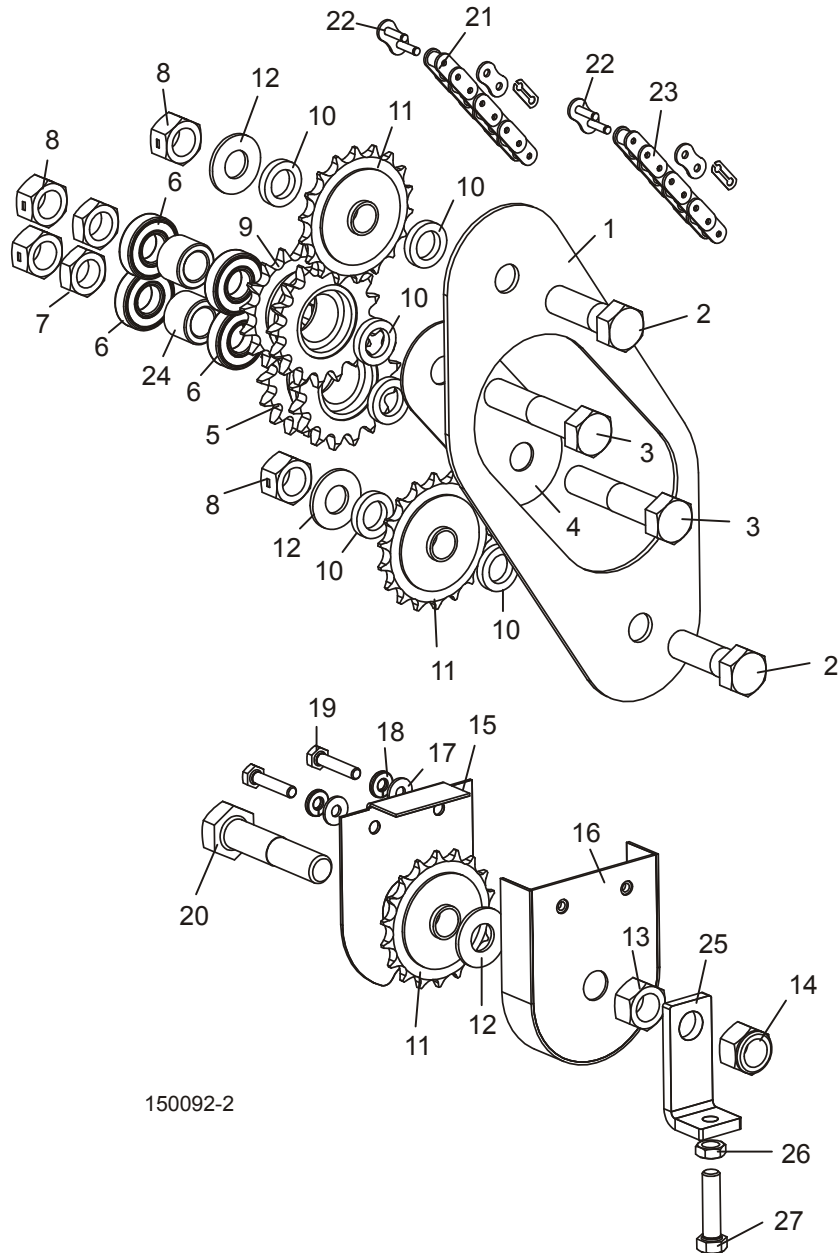

150092-2

REF	DESCRIPTION (◆ Indicates Parts Available In Assemblies Only)	PART #	QTY.
1	PLATE, UP/DOWN IDLER SPROCKET MOUNT	014907	1
2	BOLT, 5/8-11 X 2" HEX HEAD GRADE 2	F05009-2	2
3	BOLT, 5/8-11 X 3" HEX HEAD GRADE 2	F05009-32	2
4	PLATE, UP/DOWN DRIVE SPROCKET MOUNT	014908	1
5	SPROCKET WELDMENT, DUAL 17/17T	W12474	1
6	BEARING, R-10	P04156	4

7	NUT, 5/8-11 HEX JAM	F05010-82	2	
8	NUT, 5/8-11 HEX LOCK	F05010-4	4	
9	SPROCKET WELDMENT, DUAL 16/17T	W12476	1	
10	SPACER, 41/64" X 1" X 3/16"	S12480	6	
11	SPROCKET, #40 IDLER 17T 5/8" I.D.	P04333	3	
12	WASHER, 5/8" SAE FLAT	F05011-5	5	
13	NUT, 5/8-11 HEX	F05010-5	1	
14	NUT, 5/8-11 HEX NYLON LOCK	F05010-34	1	
15	COVER, UP/DOWN LOWER SPROCKET	015859	1	
16	COVER WELDMENT, UP/DOWN LOWER SPROCKET	015860	1	
17	WASHER, 1/4" SAE FLAT	F05011-11	2	
18	WASHER, 1/4" SPLIT LOCK	F05011-14	2	
19	BOLT, 1/4-20 X 1 1/4" HEX HEAD FULL THREAD	F05005-3	2	
20	BOLT, 5/8-11 X 3" HEX HEAD FULL THREAD	F05009-1	1	
21	CHAIN, #40 X 111 1/2" ROLLER	014831	1	
22	LINK, #40 MASTER	P04200	2	
23	CHAIN, #40 X 14 1/2" ROLLER	036102 <sup>1</sup>	1	
24	SPACER, 41/64" X 1" X 3/4"	015503 <sup>2</sup>	2	
25	BRACKET, UP/DOWN CHAIN TENSIONER	016720 <sup>3</sup>	1	
26	NUT, 3/8-16 HEX JAM	F05010-29	1	
27	BOLT, 3/8-16 X 1 1/2" HEX HEAD FULL THREAD	F05007-17	1	

<sup>1</sup> Replaces P12496 Roller Chain #40 X 15 1/2" (10/02).

<sup>2</sup> Two 015503 Spacers added Rev. D7.00 to prevent preloading of sprocket bearings.

<sup>3</sup> Tensioner Bracket 016720 added Rev. D7.00 to assist tensioning of up/down chain. Bracket may be added to previous revisions (requires bolt F05007-17 and jam nut F05010-29).

## SECTION 6 FEED SYSTEM & TRACK ROLLERS

For Feed Crank Handle, [See Section 5.2.](#)

### 6.1 Track Rail, Rollers, & Travel Pins

LT15

Rev. D6.00 - E3.02

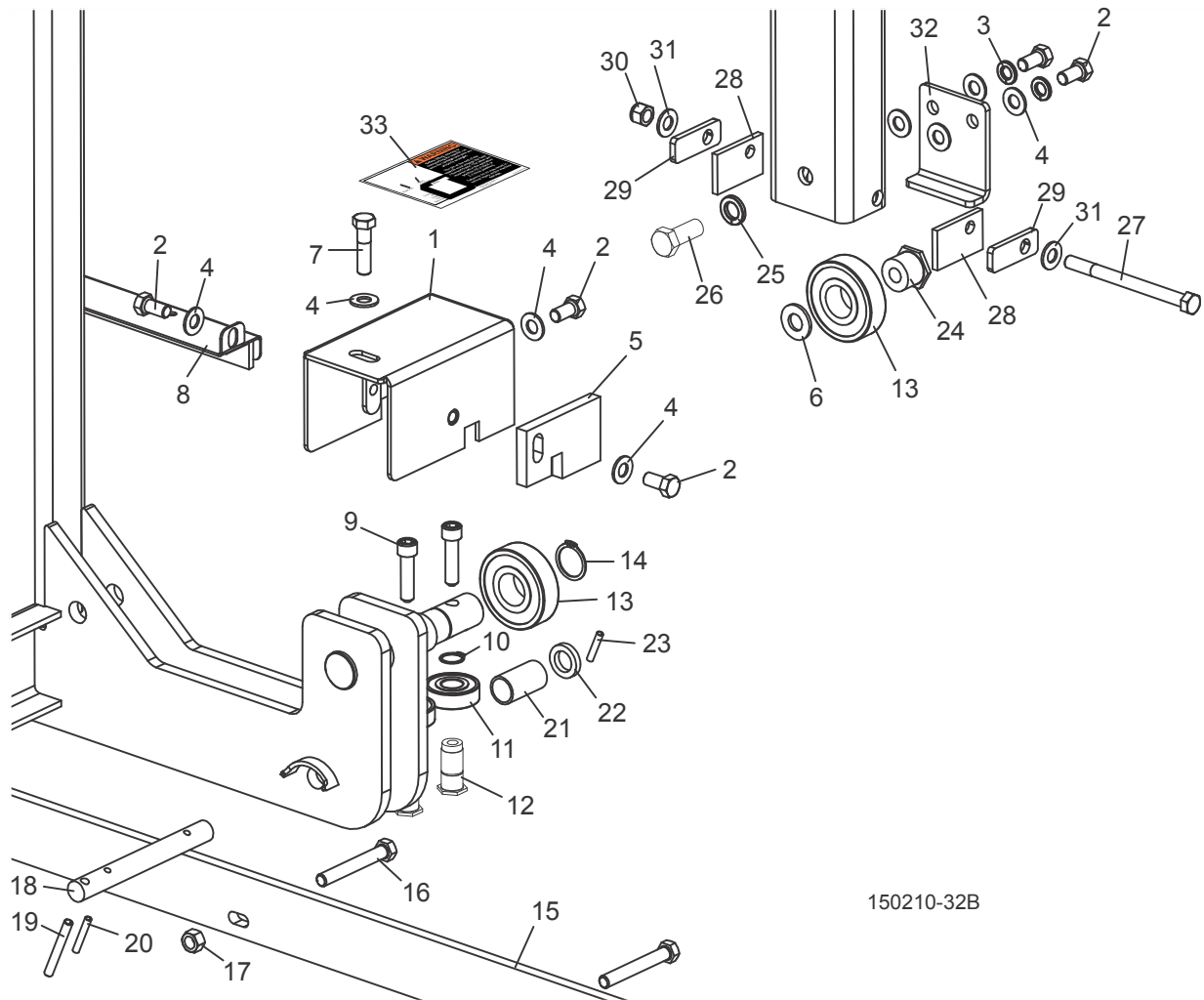

150210-32B

REF	DESCRIPTION (◆ Indicates Parts Available In Assemblies Only)	PART #	QTY.
1	COVER WELDMENT, TRACK ROLLER	015846	2
2	BOLT, 3/8-16 X 3/4" HEX HEAD	F05007-27	8
3	WASHER, 3/8" SPLIT LOCK	F05011-4	2
4	WASHER, 3/8" SAE FLAT	F05011-3	8
5	PLATE, TRACK WIPER	014906	2
6	WASHER, 1/2" SAE FLAT	F05011-2	1



## Feed System & Track Rollers

*Track Rail, Rollers, & Travel Pins*

6

7	<b>BOLT, 3/8-16 X 1 1/2" HEX HEAD</b>	F05007-78	2	
8	<b>COVER, MIDDLE TRACK WITH FELT</b>	016052	1	
9	<b>BOLT, 3/8-16 X 1 1/2" SOCKET HEAD</b>	F05007-36	4	
10	<b>RING, 5/8" (5100-62) OUTER RETAINING</b>	F04254-2	4	
11	<b>BEARING, 5/8" X 1.75" X .47"</b>	P06030-1	4	
12	<b>SHAFT, SIDE BEARING MOUNT</b>	014932	4	
13	<b>BEARING, .98" X 2.44" X .67"</b>	P08066	3	
14	<b>RING, 25MM (5100-98) OUTER RETAINING</b>	F04254-26	2	
15	<b>RAIL, PINNED 80.5" LONG BED</b>	016489	2	
16	<b>BOLT, 3/8-16 X 2 3/4" HEX HEAD FULL THREAD</b>	F05007-230	24	
17	<b>NUT, 3/8-16 HEX LOCK</b>	F05010-25	24	
18	<b>PIN, TRAVEL LOCK</b>	014899	2	
19	<b>PIN, 1/4" X 2" ROLL</b>	F05012-46	2	
20	<b>PIN, 3/16" X 1 1/4" ROLL</b>	F05012-16	2	
21	<b>SPRING, 7/8" O.D. X 1 1/2" COMPRESSION</b>	P07997	2	
22	<b>WASHER, 41/64" ID X 1" OD X 3/16" THICK</b>	S12480	2	
23	<b>PIN, 3/16" X 1" ROLL</b>	F05012-11	2	
24	<b>SHAFT, IDLE SIDE ROLLER MOUNT</b>	014974	1	
25	<b>WASHER, 1/2" SPLIT LOCK</b>	F05011-9	1	
26	<b>BOLT, 1/2-13 X 1 1/4" HEX HEAD GRADE 5</b>	F05008-37	1	
	<b>BRACKET ASSEMBLY, IDLE WIPER</b>	074251 <sup>1</sup>	1	
27	Bolt, 3/8-16 x 4 1/2" Hex Head Grade 5	F05007-35	1	
28	Felt, Idle Wiper	074270	2	
29	Bracket, Left Idle Wiper	074250	2	
30	Nut, 3/8-16 Hex Nylon Lock	F05010-10	1	
31	Washer, 3/8" SAE Flat	F05011-3	2	
32	<b>PLATE, IDLE SIDE GUIDE</b>	014897	1	
33	<b>DECAL, LOCK PIN WARNING</b>	017926	2	

<sup>1</sup> Replaced Left (016050) and Right (016051) Idle Side Wiper Bracket Assemblies (Rev. E7.04).

# 6 Feed System & Track Rollers

## Track Rail, Rollers, & Travel Pins

### 6.2 Track Rail, Rollers, & Travel Pins

LT15

Rev. A1.00 - D5.00

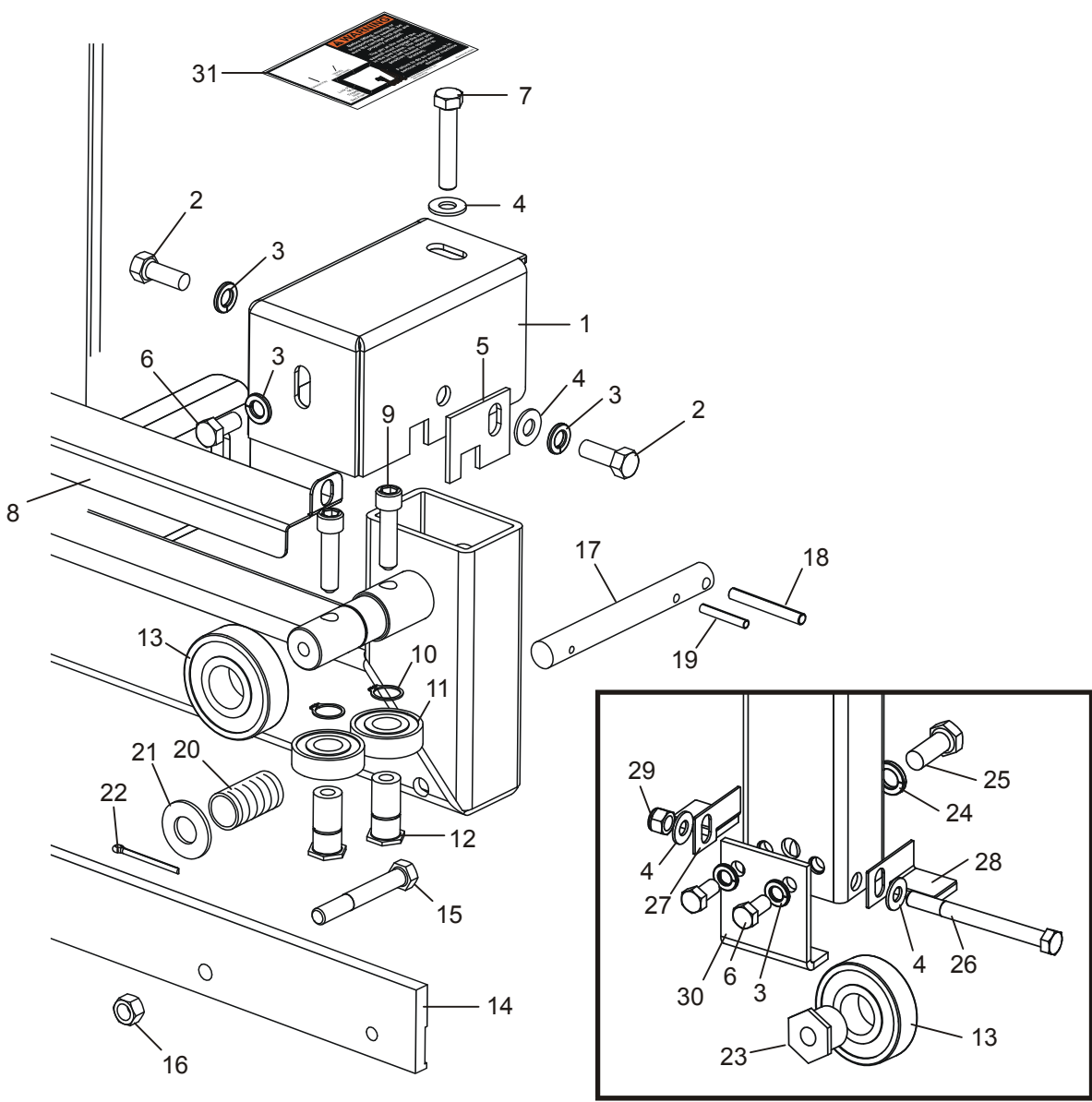

REF	DESCRIPTION (◆ Indicates Parts Available In Assemblies Only)	PART #	QTY.
1	COVER WELDMENT, TRACK ROLLER	015846 <sup>1</sup>	2
2	BOLT, 3/8-16 X 1" HEX HEAD	F05007-7	4
3	WASHER, 3/8" SPLIT LOCK	F05011-4	8
4	WASHER, 3/8" SAE FLAT	F05011-3	6
5	PLATE, TRACK WIPER	014906	2
6	BOLT, 3/8-16 X 3/4" HEX HEAD GRADE 2	F05007-27	4

7	<b>BOLT, 3/8-16 X 2" HEX HEAD FULL THREAD</b>	F05007-16	2	
8	<b>COVER, MIDDLE TRACK WITH FELT</b>	016052 <sup>2</sup>	1	
9	<b>BOLT, 3/8-16 X 1 1/2" SOCKET HEAD</b>	F05007-36	4	
10	<b>RING, 5/8" (5100-62) OUTER RETAINING</b>	F04254-2	4	
11	<b>BEARING, 5/8" X 1.75" X .47"</b>	P06030-1	4	
12	<b>SHAFT, SIDE BEARING MOUNT</b>	014932	4	
13	<b>BEARING, .98" X 2.44" X .67"</b>	P08066	3	
	<b>RING, 25MM (5100-98) OUTER RETAINING</b>	F04254-26	2	
14	<b>RAIL, PINNED 80.5" LONG BED</b>	016489 <sup>3</sup>	2	
	<b>RAIL, PINNED 69" LONG BED</b>	016167 <sup>3</sup>	2	
15	<b>BOLT, 3/8-16 X 2 3/4" HEX HEAD</b>	F05007-29	6	
	<b>BOLT, 3/8-16 X 3" HEX HEAD FULL THREAD</b>	F05007-1	1	
16	<b>NUT, 3/8-16 HEX LOCK</b>	F05010-25	7	
17	<b>PIN, TRAVEL LOCK</b>	014899	2	
18	<b>PIN, 1/4" X 2" ROLL</b>	F05012-46	2	
19	<b>PIN, 3/16" X 1 1/4" ROLL</b>	F05012-16	2	
20	<b>SPRING, 7/8" O.D. X 1 1/2" COMPRESSION</b>	P07997	2	
21	<b>WASHER, 41/64" ID X 1" OD X 3/16" THICK</b>	S12480 <sup>4</sup>	2	
22	<b>PIN, 3/16" X 1" ROLL</b>	F05012-11 <sup>4</sup>	2	
23	<b>SHAFT, IDLE SIDE ROLLER MOUNT</b>	014974	1	
24	<b>WASHER, 1/2" SPLIT LOCK</b>	F05011-9	1	
25	<b>BOLT, 1/2-13 X 1 1/4" HEX HEAD GRADE 5</b>	F05008-37	1	
26	<b>BOLT, 3/8-16 X 4" HEX HEAD GRADE 2</b>	F05007-4	1	
27	<b>BRACKET ASSEMBLY, LEFT IDLE SIDE WIPER</b>	016050 <sup>5</sup>	1	
28	<b>BRACKET ASSEMBLY, RIGHT IDLE SIDE WIPER</b>	016051 <sup>5</sup>	1	
29	<b>NUT, 3/8-16 HEX NYLON LOCK</b>	F05010-10	1	
30	<b>PLATE, IDLE SIDE GUIDE</b>	014897	1	
31	<b>DECAL, LOCK PIN WARNING</b>	016569 <sup>6</sup>	2	

<sup>1</sup> Replaces 014910 originally shown in parts manual. Cover weldment includes weld nuts and paint.

<sup>2</sup> Middle track cover with felt replaces middle track cover 015845 supplied before Rev. B.00. Oil holes and rope pulley cover extension added 2/00.

<sup>3</sup> Use 69" Rail 016167 for LT15 Rev. A1.00 - D3.00 Bed Rev. A.00 - B.00). Use 80.5" Rail 016489 for LT15 Rev. D4.00+ (Bed Rev. C.00+). Pinned Rail 016167 replaces 014842 used prior to Rev. B.00. If attaching bed rail 014842 to pinned bed rail 016167, bed rail adaptor splice 016173 must be used.

<sup>4</sup> Smaller diameter spacer S12480 replaces 5/8" SAE Flat Washer F05011-5 and 1" roll pin F05012-11 replaces 1 1/2" cotter pin F05012-49 with bed change (Bed Rev. F.00) to eliminate interference with new bed cross brace. Retrofit kit 006023 available for sawmills originally equipped with flat washers. Kit includes two washers, roll pins and instructions.

<sup>5</sup> Right and left track wipers with felt replace track wiper 014971 supplied before Rev. B.00. Oiler holes added 2/00.

<sup>6</sup> Added to LT15 Rev. D4.01. Decals sent to all customers with previous revision LT15 sawmills (8/00).

### 6.3 Manual Feed

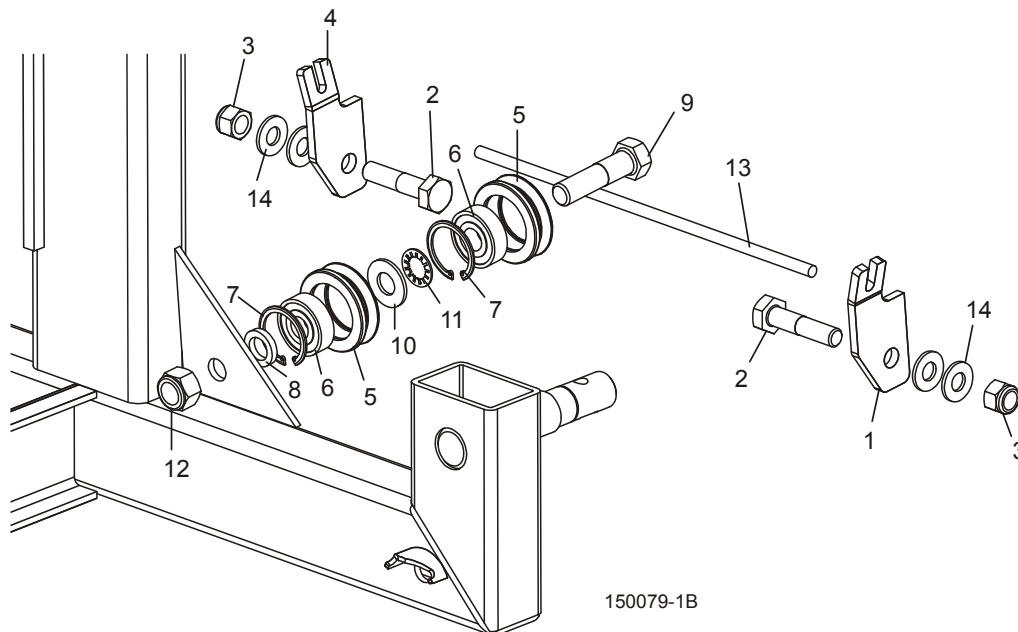

REF	DESCRIPTION (◆ Indicates Parts Available In Assemblies Only)	PART #	QTY.
1	BRACKET, FRONT ROPE MOUNT	014957	1
2	BOLT, 1/2-13 X 2 1/4" HEX HEAD GRADE 5	F05008-10	2
3	NUT, 1/2-13 HEX NYLON LOCK	F05010-8	2
4	BRACKET, REAR ROPE MOUNT	014958	1
	<b>ROLLER ASSEMBLY, ROPE GUIDE WITH BEARING</b>	A09059 <sup>1</sup>	2
5	Roller, Rope Guide V-Groove	S07989	1 ◆
6	Bearing, 5/8" I.D. 6203-2NSL	P06030-1	1
7	Ring, 1.575" ID Beveled 5002-156 Retaining	F04254-8 <sup>1</sup>	1
8	SPACER, 41/64" X 1" X 3/16"	S12480 <sup>1</sup>	1
9	BOLT, 5/8-11 X 2 1/2" HEX HEAD GRADE 5	F05009-20 <sup>1</sup>	1
10	WASHER, 5/8" SAE FLAT	F05011-5 <sup>1</sup>	1
11	WASHER, 5/8" INTERIOR STAR LOCK	F05011-25 <sup>1</sup>	1
12	NUT, 5/8-11 HEX NYLON LOCK	F05010-34	1
13	ROPE, 5/16" DIA. SOLID BRAIDED POLYESTER	R02080 <sup>2</sup>	30 Ft.
14	WASHER, 1/2" SAE FLAT	F05011-2 <sup>3</sup>	4

<sup>1</sup> Upgraded V-Groove rollers supplied after Rev. D4.00. Roller changed to bearing secured with retaining ring to insure proper fit. New roller requires longer mounting bolt F05009-20 (replaces 5/8-11 x 2" hex bolt F05009-2) one flat washer F05011-5, one star lock washer F05011-25 and one spacer S12480.

<sup>2</sup> 30-Foot section of rope used for LT15 with up to three bed sections. Add 6 feet for each additional bed section.

<sup>3</sup> Washers added and bracket configuration modified (Rev. D7.00) to allow maximum log capacity. Replace one flat washer with spacer 033911 for beds after Rev. F.00 to provide maximum feed travel length.

## SECTION 7 BED FRAME ASSEMBLY

### 7.1 Auxiliary Bed Rail Assembly

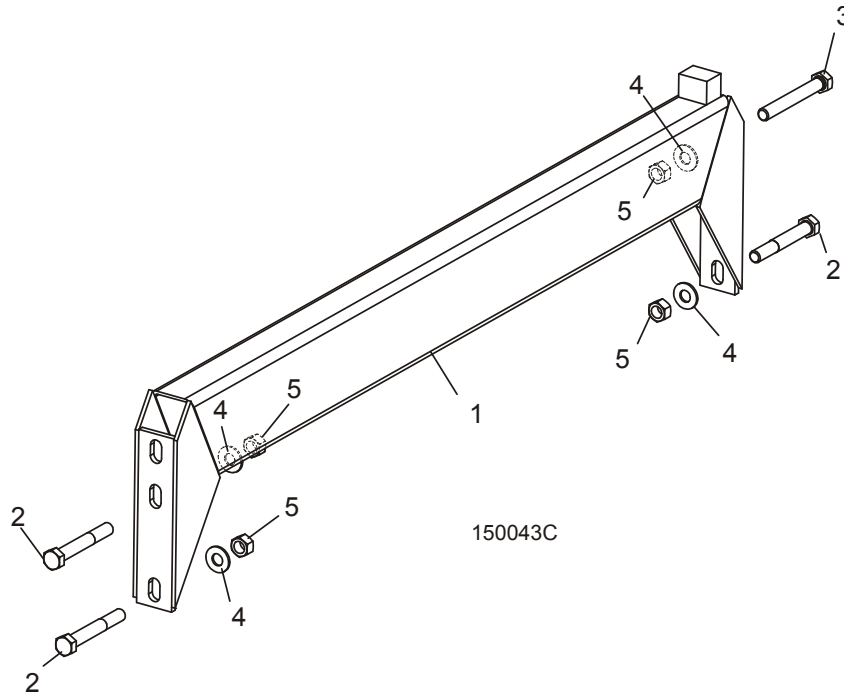

REF	DESCRIPTION (◆ Indicates Parts Available In Assemblies Only)	PART #	QTY.	
	<b>RAIL KIT, LT15 SLR AUXILIARY BED</b>	016037 <sup>1</sup>	2	
1	Rail Weldment, Auxiliary Bed w/Block	016036	1	◆
2	Bolt, 3/8-16 x 2 3/4" Hex Head	F05007-29	3	
3	Bolt, 3/8-16 x 3" Full Thread Hex Head	F05007-1	1	
4	Washer, 3/8" SAE Flat	F05011-3	4	
5	Nut, 3/8-16 Hex Lock	F05010-25	4	
	Instruction Sheet, LT15 SLR Bed Rail Installation	016037-829	1	

<sup>1</sup> 016037 required to use the Shingle Lap Siding Option on the LT15 Sawmill. 016037 Auxiliary Bed Rail replaces 015837 originally supplied prior to Rev. D4.00 to support short logs. Two Auxiliary Bed Rails supplied after Rev. D7.00.

# 7 Bed Frame Assembly

## Log Wedge, Loading Ramps, & Cant Hook (Optional)

### 7.2 Log Wedge, Loading Ramps, & Cant Hook (Optional)

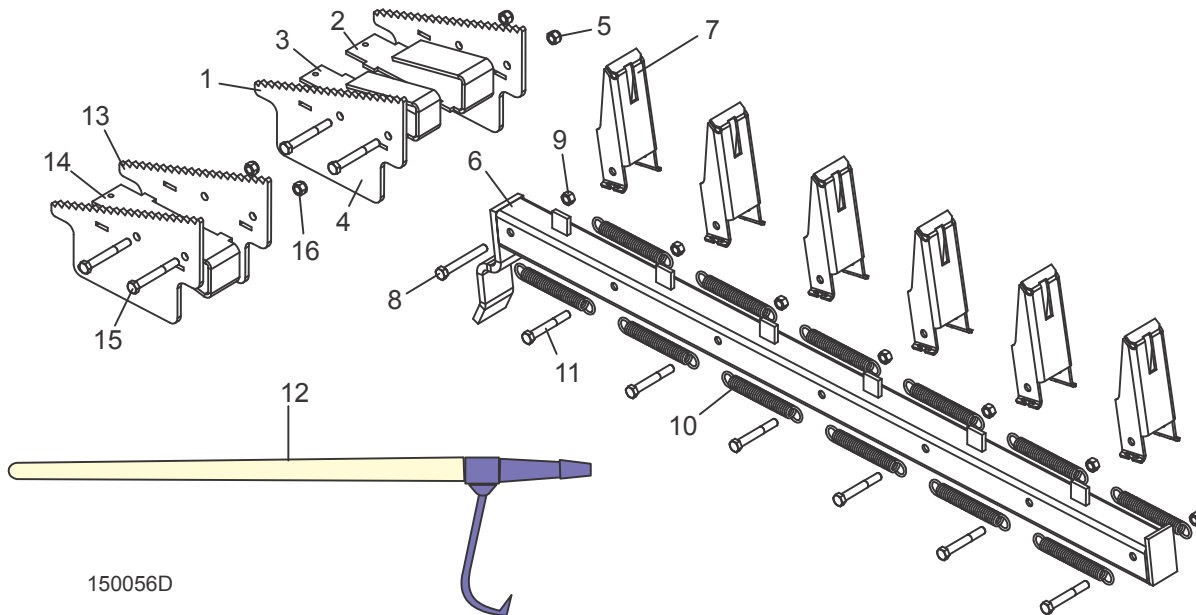

REF	DESCRIPTION (◆ Indicates Parts Available In Assemblies Only)	PART #	QTY.	
	<b>WEDGE ASSY, LOG TAPER</b> (Included with LT15OP Optional Package)	015809 <sup>1</sup>	1	
1	Plate, LT15 Wedge	015807	2	
2	Bracket, LT15 Wedge Bed Rev. G.00+ Spacer	007073 <sup>1</sup>	1	
3	Bracket, LT15 Wedge Old Bed Spacer	015808 <sup>1</sup>	1	
4	Bolt, 3/8-16 x 3" Hex Head Grade 5	F05007-73	2	
5	Nut, 3/8-16 Hex Nylon Lock	F05010-10	2	
	<b>RAMP ASSEMBLY, LOG LOADING</b> (Included with LT15OP Optional Package)	015804	2	
6	Ramp Weldment, Log Loading	015803	1	◆
7	Bracket, Log Loading Stop	S08329	6	
8	Bolt, 3/8-16 x 3" Hex Head Full Thread	F05007-1	1	
9	Nut, 3/8-16 Hex Nylon Lock	F05010-10	7	
10	Spring, .563" O.D. x .072" x 5" Extension	P04060	12	
11	Bolt, 3/8-16 x 2 3/4" Hex Head	F05007-29	6	
12	<b>HOOK, CANT (INCLUDED WITH LT15OP OPTIONAL PACKAGE)</b>	CH	1	
	<b>WEDGE ASSEMBLY, LOG TAPER LT15 WIDE</b> (Included with All LT15 Wide Head Only)	074403	1	
13	Plate, LT15 Wedge	015807	2	◆
14	Bracket, LT15 Wedge (LT15BS Rev. G.00+)	007073	1	◆
15	Bolt, 3/8-16 x 3" Hex Head Grade 5	F05007-73	2	
16	Nut, 3/8-16 Hex Nylon Lock	F05010-10	2	

<sup>1</sup> Wedge weldment 015809 changed to assembly 4/09. Use 007073 spacer bracket for Bed Sections G.00 and later. Use 015808 for older beds.

### 7.3 Bed Connecting Hardware

LT15

Rev. B.00 - E3.02

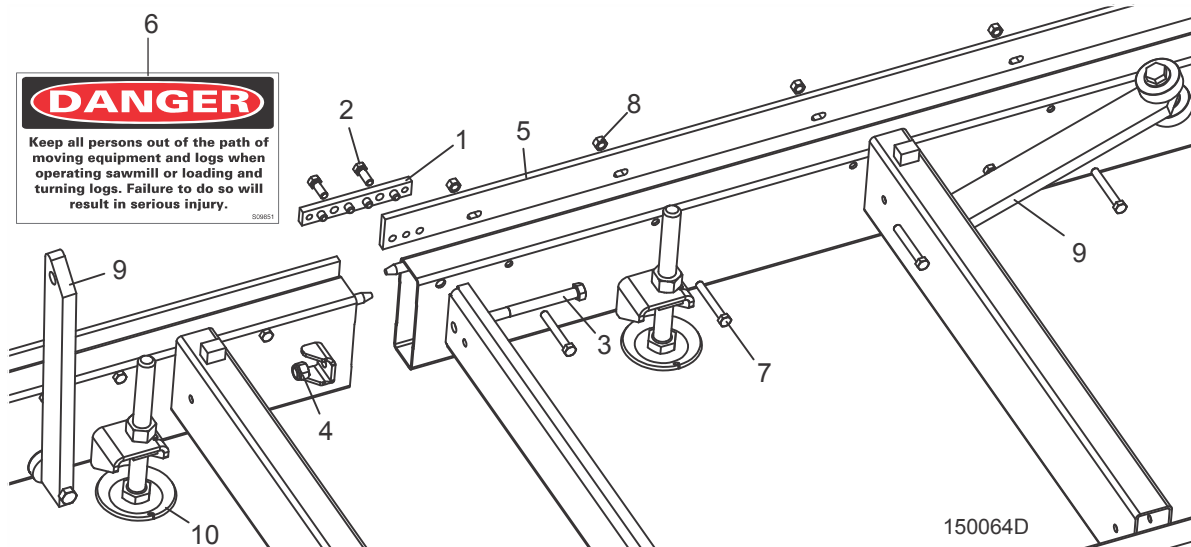

**DANGER**  
Keep all persons out of the path of moving equipment and logs when operating sawmill or loading and turning logs. Failure to do so will result in serious injury.

REF	DESCRIPTION (◆ Indicates Parts Available In Assemblies Only)	PART #	QTY.
	<b>BED ASSEMBLY, 6'-8" LT15 EXTENSION</b>	LT15BS	2
1	Splice Assembly, Pinned Bed Rail	016170	1
2	Bolt, 3/8-16 X 1" Grade 5 Hex Head	F05007-87	2
3	Bolt, 1/2-13 X 5" Grade 5 Hex Head	F05008-66 <sup>1</sup>	4
4	Nut, 1/2-13 Hex Nylon Lock	F05010-8	4
5	Rail, Pinned 80.5" Long Bed	016489 <sup>2</sup>	1
	Rail, Pinned 69" Long Bed	016167 <sup>2</sup>	1
6	Decal, Keep Away Danger	S09851	1
7	Bolt, 3/8-16 x 2 3/4" Hex Head Full Thread	F05007-230	8
8	Nut, 3/8-16 Swaged Lock	F05010-25	8
9	Side Support Parts ( <a href="#">See Section 7.7</a> )		
10	Leg Parts ( <a href="#">See Section 7.5</a> )		
	Lock Pin Retrofit Parts ( <a href="#">See Section 6.2</a> )		

<sup>1</sup> Replaces F05008-35 4 1/2" bolt to ensure adequate nut engagement (Rev E6.05, Bed Rev. G.01).

<sup>2</sup> Use 69" Rail 016167 for LT15 Rev. A1.00 - D3.00 (Bed Rev. A.00 - B.00). Use 80.5" Rail 016489 for LT15 Rev. D4.00+ (Bed Rev C.00+).

# 7 Bed Frame Assembly

## Bed Connecting Hardware

### 7.4 Bed Connecting Hardware

LT15BS

Rev. A.00

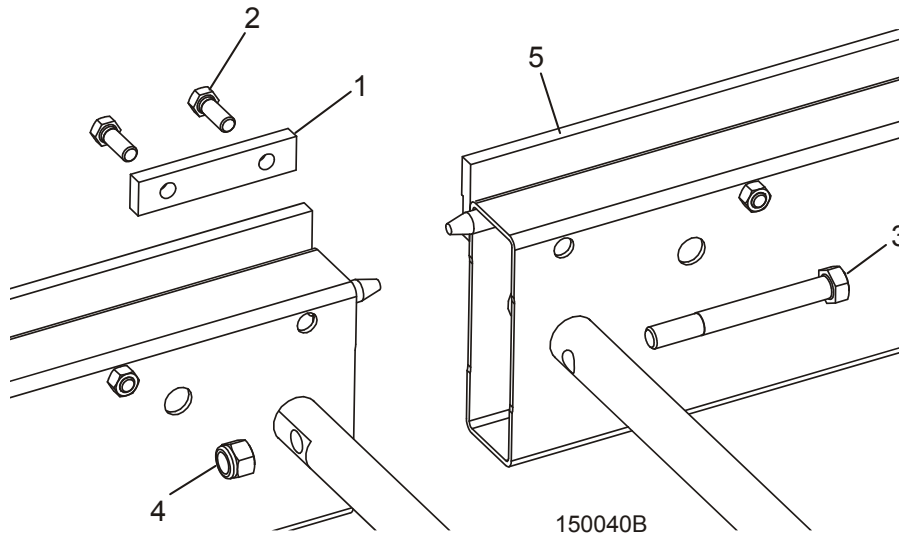

REF	DESCRIPTION (◆ Indicates Parts Available In Assemblies Only)	PART #	QTY.	
1	PLATE, BED CONNECTION	014881	1	
2	BOLT, 3/8-16 X 1" GRADE 5 HEX HEAD	F05007-87	2	
3	BOLT, 1/2-13 X 4 1/2" GRADE 5 HEX HEAD	F05008-35	4	
4	NUT, 1/2-13 HEX NYLON LOCK	F05010-8	4	
5	RAIL, BED	014842 <sup>1</sup>	1	◆

<sup>1</sup> No Longer Available. Order Pinned Bed Rail 016167 ([See Section 7.3](#)). If attaching bed rail 014842 to pinned bed rail 016167, bed rail adaptor splice 016173 must be used.



## 7.5 Leg Assembly

LT15BS Rev. E.00+

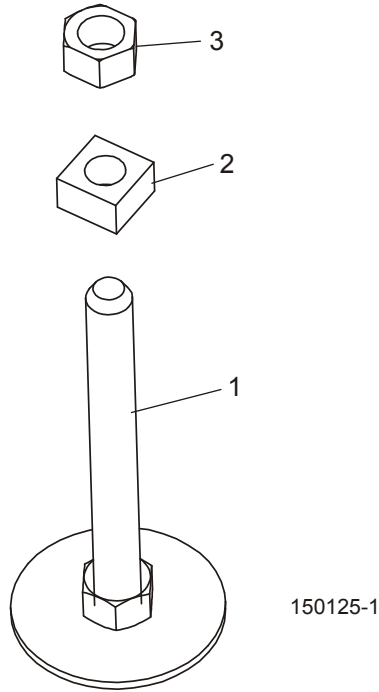

REF	DESCRIPTION (◆ Indicates Parts Available In Assemblies Only)	PART #	QTY.	
1	LEG WELDMENT, LT15 2004	046615	4	
2	NUT, 7/8-9 SQUARE	F05010-186	4	
3	NUT, 7/8-9 HEX	F05010-136	4	

# 7 Bed Frame Assembly

## Leg Assembly

### 7.6 Leg Assembly

LT15BS Rev. A.00 - D.06

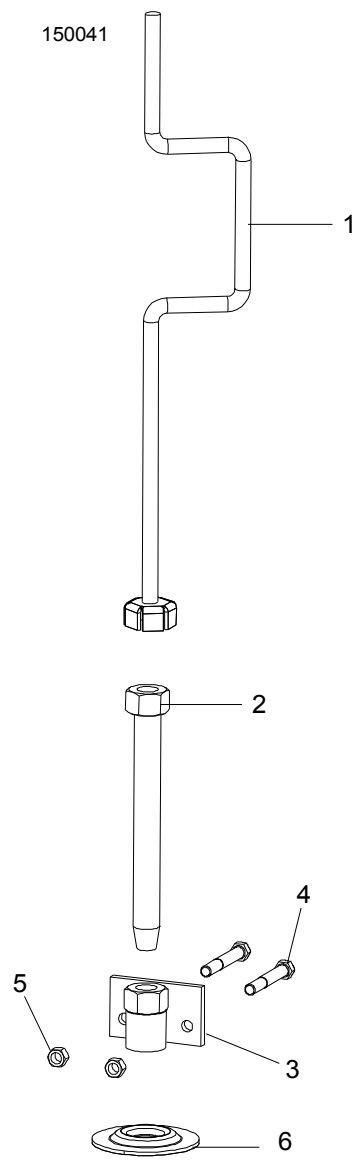

REF	DESCRIPTION (◆ Indicates Parts Available In Assemblies Only)	PART #	QTY.
1	WRENCH WELDMENT, LEG ADJUSTMENT	014937	1
2	LEG, ADJUSTABLE	014833	8
3	BRACKET WELDMENT, LEG MOUNT	014854	8
4	BOLT, 3/8-16 X 2 3/4" HEX HEAD	F05007-29	16
5	NUT, 3/8-16 HEX LOCK	F05010-25	16
6	PLATE, FOOT	014909	8

## 7.7 Log Side Support Assembly

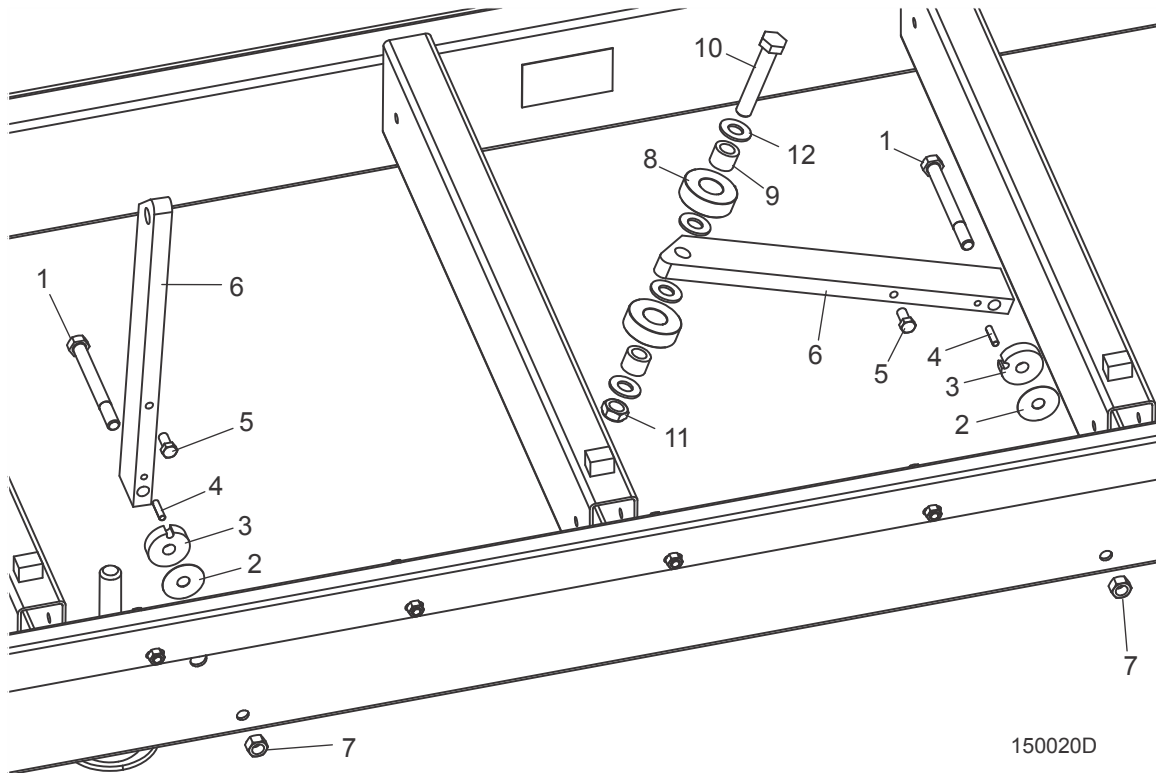

REF	DESCRIPTION (◆ Indicates Parts Available In Assemblies Only)	PART #	QTY.
1	BOLT, 1/2-13 X 5" HEX HEAD CAP GRADE 5	F05008-66	2
2	WASHER, 33/64 X 1 3/4 X 1/32" NYLON	014972	2
3	WASHER, 1/2" LOG SIDE SUPPORT	025767 <sup>1</sup>	2
	WASHER, 3/8" LOG SIDE SUPPORT	014856 <sup>1</sup>	2
4	PIN, 1/4 X 1" ROLL	F05012-7	2
5	BOLT, 3/8-16 X 3/4" HEX HEAD GRADE 5 W/NYLON PATCH	F05007-168	2
6	SUPPORT, LOG SIDE	014855	2
7	NUT, 1/2-13 HEX LOCK	F05010-3	2
	ROLLER ASSEMBLY, LT15 SIDE SUPPORT	074276	1
8	Roller, Side Support	016561	2
9	Bushing, Bronze 5/8" x 1" x 3/4"	016560	2
10	Bolt, 5/8-11 x 3 1/2" Hex Head Grade 5	F05009-93	1
11	Nut, 5/8-11 Jam Nylon Lock	F05010-96	1
12	Washer, 5/8" SAE Flat	F05011-5	4

<sup>1</sup> Thicker 1/2" washer 025767 replaced 3/8" washer 014856 7/10 (LT15BS Rev. G.02) to ensure side supports are positioned inside stop blocks on bed rails. Replace washers on older bed sections to ensure compatibility with current bed sections.

# 7 Bed Frame Assembly

## Log Clamp

### 7.8 Log Clamp

LT15

Rev. E3.02

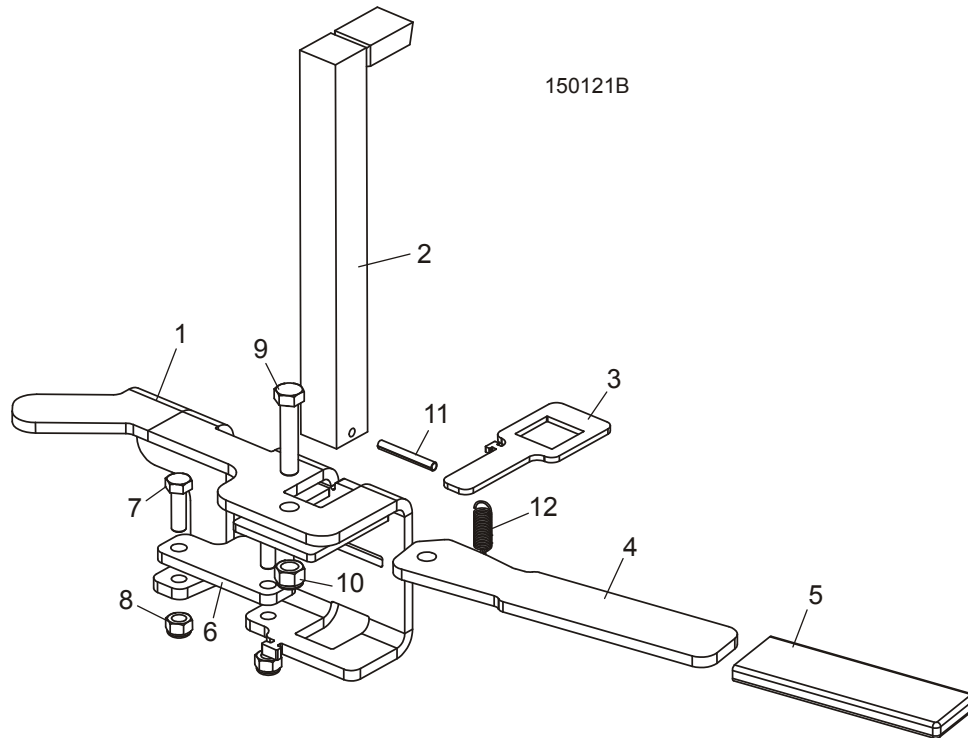

REF	DESCRIPTION (◆ Indicates Parts Available In Assemblies Only)	PART #	QTY.
	<b>CLAMP ASSEMBLY, LT15 LOG</b>	046620 <sup>1</sup>	2
1	Lock Weldment, LT15 Clamp	046621	1
2	Post Assembly, LT15 Clamp	046619 <sup>2</sup>	1
3	Plate, Clamp Lock	046587	1
4	Plate, Cam Handle	046589	1
5	Cover, LT15 Clamp Handle	016726	1
6	Plate, Clamp Lower	046582	1
7	Bolt, 5/16-18 x 1" Hex Head Grade 5	F05006-27	2
8	Nut, 5/16-18 Hex Nylon Lock	F05010-58	2
9	Bolt, 3/8-16 x 1 3/4" Hex Head Grade 5	F05007-119 <sup>3</sup>	1
10	Nut, 3/8-16 Hex Nylon Lock	F05010-10	1
11	Pin, 3/16" x 1 1/2" Roll	F05012-17	1
12	Spring, .375" OD x 1.25" Extension	046645	1

<sup>1</sup> Log Clamp Retrofit Kit 065661 is now available for service.

<sup>2</sup> Clamp post weldment 046619 changed to assembly to improve durability (12/05).

<sup>3</sup> Replaces F05007-129 Full Thread bolt previously listed before 10/07. F05007-119 has always been used in production.

## 7.9 Log Clamp

LT15

Rev. D6.00 - E3.01

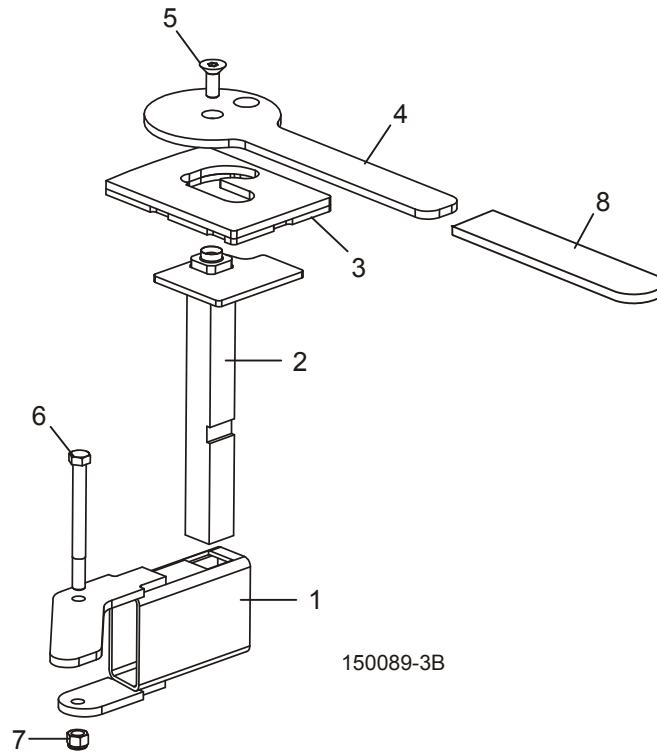

REF	DESCRIPTION (◆ Indicates Parts Available In Assemblies Only)	PART #	QTY.	
	<b>CLAMP ASSEMBLY, LT15 LOG</b>	016466 <sup>1</sup>	2	◆
1	Tube Weldment, LT15 Log Clamp	016491	1	
2	Post Weldment, LT15 Log Clamp	016460	1	
3	Plate Weldment, LT15 Log Clamp	016463	1	
4	Cam Weldment, LT15 Log Clamp	016465	1	
5	Bolt, 3/8-16 x 1" Flat Socket Head	F05007-64	1	
6	Bolt, 3/8-16 x 4" Hex Head Grade 2	F05007-4	1	
7	Nut, 3/8-16 Hex Nylon Lock	F05010-10	1	
8	Cover, LT15 Clamp Handle	016726 <sup>2</sup>	1	

<sup>1</sup> Clamp Assembly 016466 obsolete 11/03. Use new Clamp Assembly 046620 for service ([See Section 7.8](#)).

<sup>2</sup> Handle Covers 016726 added Rev. D7.00 to improve operator comfort. Covers can be added to previous revisions with similar style clamp.

# 7 Bed Frame Assembly

## Log Clamp

### 7.10 Log Clamp

LT15

Rev. A1.00 - D5.00

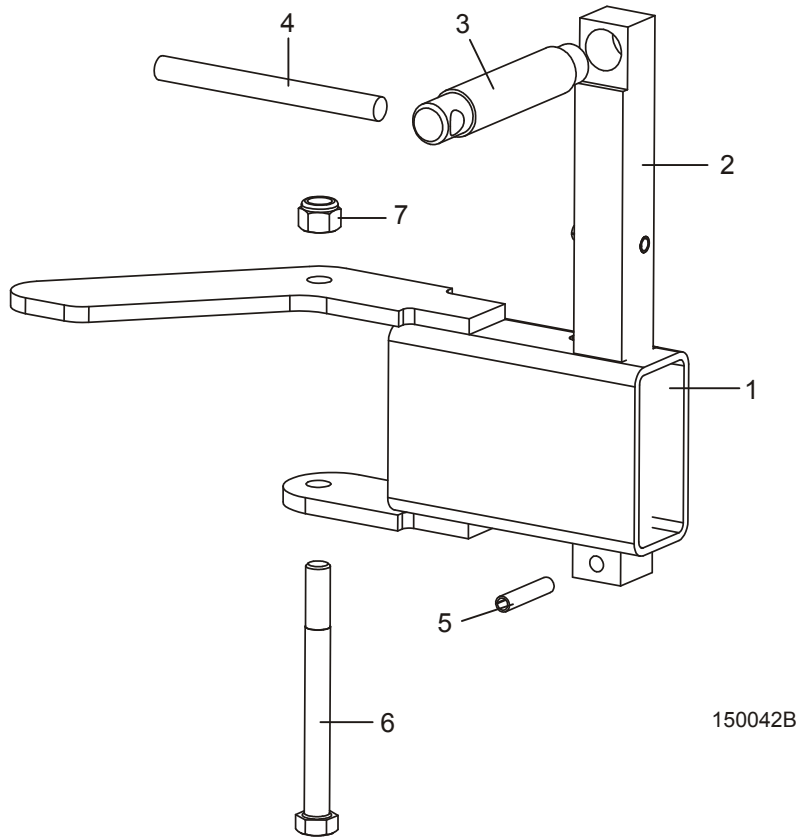

REF	DESCRIPTION (◆ Indicates Parts Available In Assemblies Only)	PART #	QTY.	
	<b>CLAMP ASSEMBLY, LT15 LOG</b>	014827 <sup>1</sup>	2	◆
1	Bracket Weldment, LT15 Log Clamp	014859 <sup>2</sup>	1	
2	Bar, LT15 Log Clamp	014860	1	
	Handle Assembly, LT15 Log Clamp	016130	1	
3	Screw, LT15 Log Clamp	014861	1	◆
4	Pin, LT15 Log Clamp Handle	014862	1	◆
5	Pin, 1/4" x 1 1/4" Roll	F05012-12	1	
6	Bolt, 3/8-16 x 4" Hex Head Grade 2	F05007-4	1	
7	Nut, 3/8-16 Hex Nylon Lock	F05010-10	1	

<sup>1</sup> Use cam-style clamp 016466 for replacement ([See Section 7.8](#)).

<sup>2</sup> Bracket weldment revised to include handle (Rev. D4.00).

## SECTION 8 MISCELLANEOUS

### 8.1 Replacement Manuals

REF	DESCRIPTION (◆ Indicates Parts Available In Assemblies Only)	PART #	QTY.
<b>Wood-Mizer Product Information</b>			
1	ALL-PRODUCTS CATALOG	PS750	1
<b>Basic Sawmill Manuals</b>			
2	TRU-SHARP BLADE HANDBOOK	M600	1
3	WOOD-MIZER GENERAL INFORMATION	M601	1
4	LT15 OPERATOR'S MANUAL	M851	1
5	LT15 PARTS MANUAL	M852	1
<b>Power Option Manuals</b>			
6	G13 ENGINE OPTION MANUAL	M800	1
7	G15 ENGINE OPTION MANUAL	M940	1
8	D51 ELECTRICAL INFORMATION	M1164	1

# INDEX

---

## B

battery box 4-6

bed rails  
  auxiliary 7-1  
  front/rear 7-1

blade guide arm 2-9

blade guides  
  drive side roller 2-5, 2-7  
  idle side roller 2-1, 2-3

blade tensioner 3-7, 3-9

blade vibration block 4-5

blade wheels  
  drive side 3-1  
  idle side 3-3, 3-5

---

## C

cant hook 7-2

covers  
  blade housing 4-5

---

## D

decals  
  saw head 4-3

---

## F

feed  
  crank assembly 6-5

feed system  
  crank assembly 5-3, 5-4  
  track rollers 6-1, 6-3  
  travel lock pins 6-1, 6-3

---

---

## L

leg assembly 7-5

loading ramps 7-2

log clamp 7-8, 7-9, 7-10

log wedge 7-2

---

## M

manuals 8-1

---

## P

parts list  
  how to use 1-1

---

## S

side supports 7-7

---

## T

track rollers  
  upper 6-1

---

## U

up/down  
  crank assembly 5-3  
  drive (gas) 5-6  
  saw head mount 5-1  
  sprocket drive 5-6

---

## W

water lube  
  bottle/tray 4-1

---