



Wood-Mizer[®] Sawmill

Parts Manual

LT70HD Wireless

rev. A9.00 - B3.01



Safety is our #1 concern! Read and understand all safety information and instructions before operating, setting up or maintaining this machine.

March 2008

Form #1552

Table of Contents

Section-Page

SECTION 1	GENERAL INFORMATION	1-1
1.1	How To Use The Parts List	1-1
1.2	Sample Assembly	1-1
SECTION 2	BLADE GUIDE ROLLERS & ARM	2-1
2.1	Blade Guide Assembly, Idle Side.....	2-1
	<i>LT60HD/70HD Rev. A8.01 - B3.01</i>	
2.2	Blade Guide Assembly, Idle Side.....	2-4
	<i>LT60HD/70HD Rev. A7.02 - A8.00</i>	
2.3	Blade Guide Assembly, Idle Side.....	2-7
	<i>LT60HD/70HD Rev. A3.01 - A7.01</i>	
2.4	Blade Guide Assembly, Drive Side.....	2-10
	<i>LT60HD/70HD Rev. A8.01 - B3.01</i>	
2.5	Blade Guide Assembly, Drive Side.....	2-13
	<i>LT60HD/70HD Rev. A7.02 - A8.00</i>	
2.6	Blade Guide Assembly, Drive Side.....	2-16
	<i>LT60HD/70HD Rev. A3.01 - A7.01</i>	
2.7	Blade Guide Arm Drive Assembly.....	2-19
SECTION 3	BLADE WHEELS & TENSIONER	3-1
3.1	Blade Drive Assembly.....	3-1
3.2	Idle Blade Wheel Assembly	3-3
	<i>LT60HD/70HD Rev. A5.03 - B3.01</i>	
3.3	Idle Blade Wheel Assembly	3-5
	<i>LT60HD/70HD Rev. A1.03 - A5.02</i>	
3.4	Hydraulic Blade Tensioner Assembly.....	3-7
	<i>LT70HD Retrofit</i>	
3.5	Hydraulic Blade Tensioner Assembly.....	3-10
	<i>LT60HD/70HD Rev. A9.00 - B3.01</i>	
3.6	Blade Tensioner Assembly.....	3-13
	<i>LT60HD/70HD Rev. A5.03 - A8.01</i>	
3.7	Blade Tensioner Assembly.....	3-15
	<i>LT60HD/70HD Rev. A3.01 - A5.02</i>	
SECTION 4	SAW HEAD	4-1
4.1	Middle Throat Screw	4-1
4.2	Belt Tensioner	4-2
4.3	Brake Assembly (DC Only)	4-4
4.4	Autoclutch Assembly (DC Only).....	4-5
	<i>LT60HD/70HD Rev. A6.00 - B3.01</i>	
4.5	Autoclutch Assembly (DC Only).....	4-7
	<i>LT60HD/70HD Rev. A3.01 - A5.03</i>	
4.6	Board Return Assembly	4-9
4.7	Water Lube Assembly	4-10
4.8	Saw Head Decals.....	4-12
	<i>LT70HD Rev. A8.00 (1/08) - B3.01</i>	
4.9	Blade Housing Covers.....	4-13
	<i>LT60HD/70HD Rev. B2.00 - B3.01</i>	

Table of Contents

Section-Page

4.10	Blade Housing Covers.....	4-15
	<i>LT60HD/70HD</i> <i>Rev. A5.00 - B1.00</i>	
4.11	Blade Housing Covers.....	4-17
	<i>LT60HD/70HD</i> <i>Rev. A3.01 - A4.01</i>	
4.12	Sawdust Chute.....	4-19
4.13	Debarker Wire Box/Grommet.....	4-20
SECTION 5	CONTROL & BATTERY BOXES	5-1
5.1	Control Assembly (DC).....	5-1
	<i>LT70HD</i> <i>Rev. B3.00 - B3.01</i>	
5.2	Control Assembly (AC).....	5-4
5.3	Control Assembly (DC).....	5-7
	<i>LT70HD</i> <i>Rev. A9.00 - B2.00</i>	
5.4	Drum Switches.....	5-10
5.5	Circuit Breakers.....	5-11
	<i>LT60HD</i> <i>Rev. B3.00 - B3.01</i>	
	<i>LT70HD</i> <i>Rev. B3.00 - B3.01</i>	
5.6	Circuit Breakers.....	5-12
	<i>LT60HD</i> <i>Rev. A7.08 - B2.00</i>	
	<i>LT70HD</i> <i>Rev. A7.08 - B2.00</i>	
5.7	Circuit Breakers.....	5-13
	<i>LT60HD</i> <i>Rev. A3.01 - A7.07</i>	
	<i>LT70HD</i> <i>Rev. A3.01 - A7.07</i>	
5.8	Front Panel Assembly & Harnesses.....	5-14
5.9	Battery Box Assembly (DC Only).....	5-16
	<i>LT60HD/70HD</i> <i>Rev. B3.00 - B3.01</i>	
5.10	Battery Box Assembly (DC Only).....	5-18
	<i>LT60HD/70HD</i> <i>Rev. A3.01 - B2.00</i>	
5.11	Fuse Box Assembly (DC Only).....	5-20
	<i>LT60HD/70HD</i> <i>Rev. B3.00 - B3.01</i>	
5.12	Fuse Box Assembly (DC Only).....	5-22
	<i>LT60HD/70HD</i> <i>Rev. A3.01 - B2.00</i>	
SECTION 6	UP/DOWN SYSTEM	6-1
6.1	Up/Down Rollers & Covers.....	6-1
6.2	Blade Height & Quarter Scales.....	6-3
6.3	Up/Down Chain & Sprockets.....	6-4
6.4	Up/Down Drive Assembly.....	6-6
6.5	Up/Down Assist Assembly.....	6-8
	<i>LT60HD/70HD</i> <i>Rev. A5.00 - B3.01</i>	
SECTION 7	FEED SYSTEM & TRACK ROLLERS	7-1
7.1	Upper Track Rollers And Wipers.....	7-1
7.2	Power Feed Assembly.....	7-3
7.3	Feed Chain/Stop.....	7-5
	<i>LT60HD/70HD</i> <i>Rev. B1.00 - B1.03</i>	
7.4	Feed Chain/Stop.....	7-7
	<i>LT60HD/70HD</i> <i>Rev. A3.03 - A9.00</i>	

Table of Contents

Section-Page

7.5	Feed Chain/Stop	7-9	
	<i>LT60HD/70HD</i>		<i>Rev. A3.01 - A9.00</i>
7.6	Lower Track Rollers.....	7-11	
SECTION 8 BED FRAME ASSEMBLY			8-1
8.1	Bed Rail Assembly, Front And Rear.....	8-1	
	<i>LT60HD</i>		<i>Rev. A7.06 - B3.01</i>
	<i>LT70HD</i>		<i>Rev. A7.06 - B3.01</i>
8.2	Bed Rail Assembly, Front And Rear.....	8-3	
	<i>LT60HD</i>		<i>Rev. A3.01 - A7.05</i>
	<i>LT70HD</i>		<i>Rev. A3.01 - A7.05</i>
8.3	Bed Rail Assembly, Middle Front.....	8-5	
8.4	Bed Rail Assembly, Middle Rear.....	8-6	
8.5	Leg Assembly (Stationary).....	8-8	
8.6	Board Return Table Assembly	8-10	
	<i>LT60HD/70HD</i>		<i>Rev. A7.09 - B3.01</i>
8.7	Board Return Table Assembly	8-11	
	<i>LT60HD/70HD</i>		<i>Rev. A3.01 - A7.08</i>
8.8	Pivot Bed Rail Assembly.....	8-13	
8.9	Log Side Support Assembly (Manual).....	8-15	
8.10	Safety Chain Assembly	8-17	
8.11	Saw Head Rest Pin Assembly	8-18	
8.12	Bed Frame Decals.....	8-19	
	<i>LT70HD</i>		<i>Rev. A8.00 (1/08) - B3.01</i>
8.13	Bed Frame Decals.....	8-20	
	<i>LT70HD</i>		<i>Rev. A3.01 - A8.00 (12/07)</i>
8.14	Board Outfeed Table (Optional).....	8-21	
SECTION 9 MISCELLANEOUS			9-1
9.1	Replacement Manuals	9-1	
SECTION 10 HYDRAULIC SYSTEM			10-1
10.1	Hydraulic Hoses	10-1	
	<i>LT60HD/70HD</i>		<i>Rev. B2.00 - B3.01</i>
10.2	Hydraulic Hoses	10-3	
	<i>LT60HD/70HD</i>		<i>Rev. A3.01 - B1.00</i>
10.3	Hydraulic Pump Box (DC).....	10-5	
10.4	Hydraulic Pump Box (230/460V AC).....	10-8	
	<i>LT60HD/70HD</i>		<i>Rev. A7.09 - B3.01</i>
10.5	Hydraulic Pump Box (575V AC).....	10-11	
	<i>LT60HD/70HD</i>		<i>Rev. A7.09 - B3.01</i>
10.6	Hydraulic Pump Box (AC).....	10-13	
	<i>LT60HD/70HD</i>		<i>Rev. A3.01 - A7.08</i>
10.7	Hydraulic Control Box (230/460V AC).....	10-16	
	<i>LT60HD/70HD</i>		<i>Rev. A7.00 - B3.01</i>
10.8	Hydraulic Control Box (230/460V AC).....	10-18	
	<i>LT60HD/70HD</i>		<i>Rev. A3.01 - A6.01</i>

Table of Contents

Section-Page

10.9	Hydraulic Control Box (575V AC).....	10-20
	<i>LT60HD/70HD Rev. A3.01 - B3.01</i>	
10.10	Hydraulic Power Supply Strip (DC Only).....	10-22
10.11	Hydraulic Power Supply Strip (AC Only).....	10-24
	<i>LT60HD/70HD (230/460V) Rev. A3.01 - A6.01</i>	
	<i>LT60HD/70HD (575V) Rev. A3.01 - B3.01</i>	
10.12	Hydraulic Log Loader	10-26
	<i>LT60HD/LT70HD Rev. A7.05 - B3.01</i>	
10.13	Hydraulic Log Loader	10-28
	<i>LT60HD/LT70HD Rev. A3.01 - A7.04</i>	
10.14	Hydraulic Log Turner.....	10-30
	<i>LT60HD/70HD Rev. B2.00 - B3.01</i>	
10.15	Hydraulic Log Turner.....	10-32
	<i>LT60HD/70HD Rev. A3.01 - B1.00</i>	
10.16	Hydraulic Log Side Supports (Front).....	10-34
10.17	Hydraulic Log Side Supports (Rear).....	10-36
10.18	Hydraulic Log Side Supports (Link).....	10-38
10.19	Hydraulic Log Clamp.....	10-39
10.20	Hydraulic Toe Board.....	10-41

INDEX

I

SECTION 1 GENERAL INFORMATION

1.1 How To Use The Parts List

- Use the table of contents or index to locate the assembly that contains the part you need.
- Go to the appropriate section and locate the part in the illustration.
- Use the number pointing to the part to locate the correct part number and description in the table.
- Parts shown indented under another part are included with that part.
- Parts marked with a diamond (◆) are only available in the assembly listed above the part.

See the sample table below. Sample Part #A01111 includes part F02222-2 and subassembly A03333. Subassembly A03333 includes part S04444-4 and subassembly K05555. The diamond (◆) indicates that S04444-4 is not available except in subassembly A03333. Subassembly K05555 includes parts M06666 and F07777-77. The diamond (◆) indicates M06666 is not available except in subassembly K05555.

1.2 Sample Assembly				
REF	DESCRIPTION (◆ Indicates Parts Available In Assemblies Only)	PART #	QTY.	
	SAMPLE ASSEMBLY, COMPLETE (INCLUDES ALL INDENTED PARTS BELOW)	A01111	1	
1	Sample Part	F02222-22	1	
	Sample Subassembly (Includes All Indented Parts Below)	A03333	1	
2	Sample Part (◆ Indicates Part Is Only Available With A03333)	S04444-4	1	◆
	Sample Subassembly (Includes All Indented Parts Below)	K05555	1	
3	Sample Part (◆ Indicates Part Is Only Available With K05555)	M06666	2	◆
4	Sample Part	F07777-77	1	

To Order Parts:

- From the continental U.S., call **1-800-525-8100** to order parts. Have your customer number, vehicle identification number, and part numbers ready when you call.
- From other international locations, contact the Wood-Mizer distributor in your area for parts.

SECTION 2 BLADE GUIDE ROLLERS & ARM

2.1 Blade Guide Assembly, Idle Side

LT60HD/70HD

Rev. A8.01 - B3.01

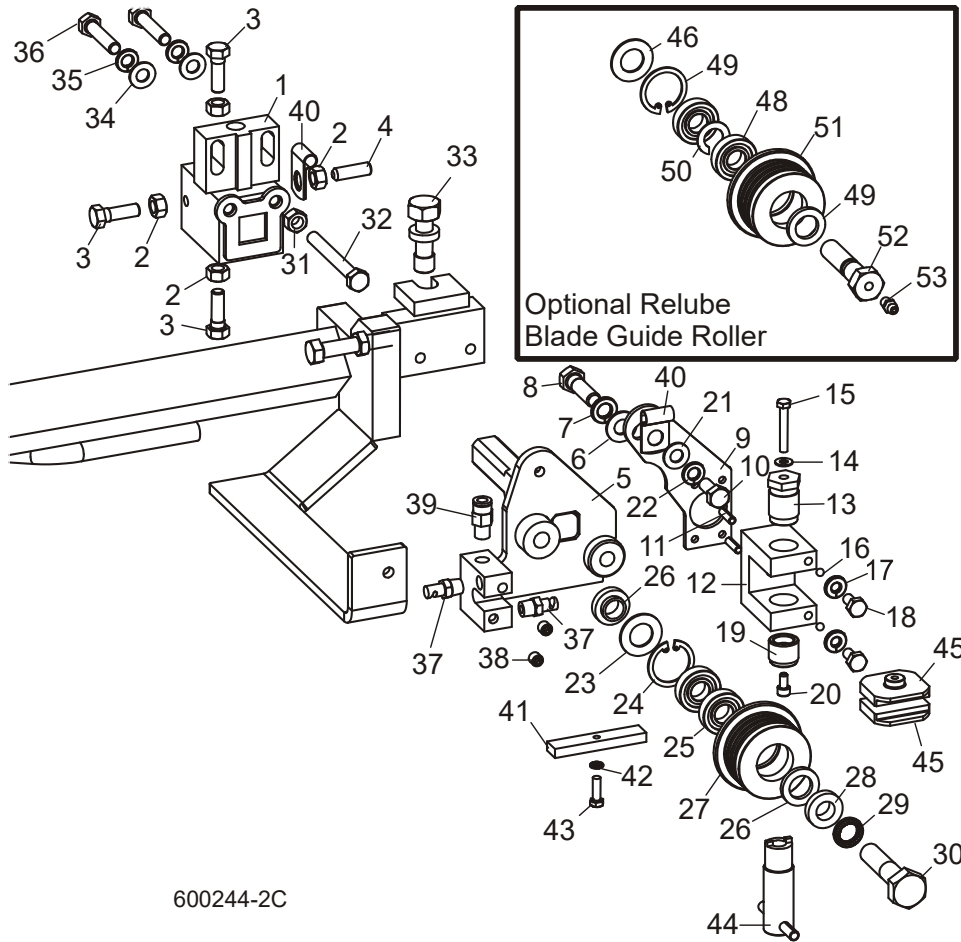

600244-2C

REF	DESCRIPTION (◆ Indicates Parts Available In Assemblies Only)	PART #	QTY.	
	ROLLER/BLOCK ASSEMBLY, IDLE SIDE (OUTER)	003926 ¹	1	
	Block Assembly, Blade Guide Mount	065677	1	
1	Block Weldment, Blade Guide Mount	003911	1	◆
2	Nut, 5/16-18 Hex	F05010-17	4	
3	Bolt, 5/16-18 x 1" Hex Head Stainless Steel	F05006-88	3	
4	Screw, 5/16-18 x 1" Socket Head Flat Point Stainless Steel Set	F05006-122	1	
5	Shaft Weldment, Idle Side Guide	003924 ²	1	
	Mount Assembly, Blade Guide Block Idle	003928	1	
6	Washer, 3/8" SAE Flat	F05011-3	1	
7	Washer, 3/8" Split Lock	F05011-4	1	

2

Blade Guide Rollers & Arm

Blade Guide Assembly, Idle Side

8	Bolt, 3/8-16 x 1 1/4" Hex Head Grade 5	F05007-123	1	
9	Plate, Block Tilt Adjustment	003915	1	
10	Bolt, 5/16-18 x 3/4" Hex Head	F05006-102	1	
11	Pin, 3/16" x 5/8" Roll	F05012-22	2	
12	Block, Guide Block Mount	003909	1	
13	Bolt, Blade Guide Block Mount	003994	1	
14	Washer, #10 Brass	042867	1	
15	Bolt, #10-32 x 1 1/4" Hex Head Stainless Steel	F05004-240	1	
16	Ball, 3/16" Dia. Nylon	003914	2	
17	Washer, 1/4" Split Lock	F05011-14	2	
18	Bolt, 1/4-20 x 1/2" Hex Head	F05005-15	2	
19	Screw, Lower Block Adjustment	044057	1	
20	Screw, #10-32 x 3/8" Socket Head Stainless Steel	F05004-200	1	
21	Washer, 5/16" SAE Flat	F05011-17	1	
22	Washer, 5/16" Split Lock	F05011-13	1	
	Roller Assembly, Blade Guide (standard for use with 1 1/4" & 1 1/2" blades)	A04925 ³	1	
	Roller Assembly, Extended Blade Guide (optional for use with 1 1/2" blades)	014299 ³	1	
	Bearing Kit, Blade Guide Rebuild	K07079	1	
23	Washer, 5/8" White Felt	P04252	1	
24	Ring, 1 1/8" Interior Retaining	F04254-1	1	
25	Bearing, R8-2RS Blade Guide	015975	2	◆
26	Washer, 5/8" Gray Felt	P06455	1	
	Screw, 1/4-28 x 1/4" Socket Head Cup Point Set Black Oxide	F05005-105	1	
	Instruction Sheet, Blade Guide Rebuild	057407-1507	1	
27	Roller, Flanged Blade Guide (1 1/4" & 1 1/2" blade)	S04250	1	◆
	Roller, Flanged Blade Guide (1 1/2" blade)	014243	1	◆
	Instruction Sheet, Blade Guide Roller Replacement	A04925-364	1	
28	Spacer, Blade Guide	S04253	2	
29	Washer, 1/2" Nord-Lock	F05011-125 ⁴	1	
30	Bolt, 1/2-13 x 2 1/4" Hex Head Grade 5	F05008-10	1	
31	Nut, 5/16-18 Hex	F05010-17	1	
32	Bolt, 5/16-18 x 2 3/4" Hex Head Full Thread	F05006-136	1	
33	Bolt, Blade Guide Vertical Adjustment	035656	1	
34	Washer, 5/16" SAE Flat	F05011-17	2	
35	Washer, 5/16" Split Lock	F05011-13	2	
36	Bolt, 5/16-18 x 1 1/2" Hex Head Grade 5 Full Thread	F05006-76	2	
37	Fitting, Blade Lube Spray Nozzle	033479	2	
38	Fitting, 1/16" NPT Socket Pipe Plug	007734 ²	2	
39	Fitting, 1/8" NPT x 1/4" Tube	P03078 ⁵	1	
40	Clamp, 1/4" Wire 13/32" Mounting Hole	024155 ⁵	2	
41	BLOCK, BLADE GUIDE ALIGNMENT	035799	1	
42	SCREW, #10-32 X 5/8" HEX HEAD	F05004-152	1	

Blade Guide Rollers & Arm

Blade Guide Assembly, Idle Side

2

43	WASHER, #10 SPLIT LOCK	F05011-20	1	
44	TOOL, LOWER BLOCK ADJUSTMENT	044064	1	
45	BLOCK, BLADE GUIDE WEAR (STANDARD FOR 1 1/2" BLADES)	052309 ⁶	2	
	BLOCK, BLADE GUIDE WEAR (OPTIONAL FOR 1 1/4" BLADES)	052355 ⁶	2	
	BLOCK ASSEMBLY, 1" SQ. EZ-GLIDE WEAR	036347 ⁶	2	
	SHIM, .008" BLADE GUIDE BLOCK SPACER	035248	1	
	ROLLER ASSEMBLY, BLADE GUIDE RELUBE (OPTIONAL FOR USE WITH 1 1/4" & 1 1/2" BLADES)	016568 ³	1	
	ROLLER ASSEMBLY, EXTENDED BLADE GUIDE RELUBE (OPTIONAL FOR USE WITH 1 1/2" BLADES)	057405 ³	1	
	Bearing Kit, Relube Blade Guide Rebuild	057407	1	
46	Washer, 5/8" White Felt	P04252	1	
47	Ring, 1 1/8" Interior Retaining	F04254-1	1	
48	Bearing, R8-2RS Blade Guide (modified)	015975 ⁷	2	◆
49	Washer, 5/8" Gray Felt	P06455	1	
50	Spacer, Blade Guide Bearing	035411	1	
	Instruction Sheet, Blade Guide Rebuild	057407-1507	1	
51	Roller, Flanged Blade Guide (Relube 1 1/4" & 1 1/2" blade)	035426	1	◆
	Roller, Flanged Blade Guide (Relube 1 1/2" blade)	057402	1	◆
	Instruction Sheet, Blade Guide Roller Replacement	A04925-364	1	
52	BOLT, BLADE GUIDE ROLLER (RELUBE ONLY)	036161	1	
53	FITTING, 1/4-28 GREASE (RELUBE ONLY)	P05060	1	

¹ Roller/Block Assembly 003926 is no longer available. Use component parts to service or order Roller/Block Assembly 036818 for 1-1/4" blades or 065934 for 1-1/2" blades.

² Shaft Weldment 003924 modified to provide more clearance for adjustment bolts and to prevent water leaks (Rev. B3.01). New shaft requires two 1/16" NPT Pipe Plugs 007734.

³ The sawmill is equipped standard with non-greasable blade guide rollers that can be used with the standard 1 1/2" blade. The roller can also be used with 1 1/4" blades. Optional extended blade guide rollers are available for use with 1 1/2" blades. The extended rollers may provide more stability during difficult sawing, but will reduce the total amount of times the blade can be reused after sharpening. Optional relube versions of each roller configuration are also available.

⁴ Nord-Lock Washer F05011-125 replaced Split Lock Washer F05011-9 to prevent loosening due to vibration (Rev. B3.01).

⁵ Straight Tube Fitting P03078 replaced Swivel Hose Fitting P09736 and Clamps 024155 added to improve lube hose routing (Rev. B3.01).

⁶ 052309 blocks for use with 1 1/2" blade provided as standard equipment. 052355 blocks available for optional use with 1 1/4" blades. EZ-Glide blocks 036347 are available for customers who prefer this block

⁷ Bearing must be modified for use with relube roller assemblies. Remove one seal from each bearing, place open sides facing each other and place spacer 035411 between bearings.

2 Blade Guide Rollers & Arm

Blade Guide Assembly, Idle Side

2.2 Blade Guide Assembly, Idle Side

LT60HD/70HD

Rev. A7.02 - A8.00

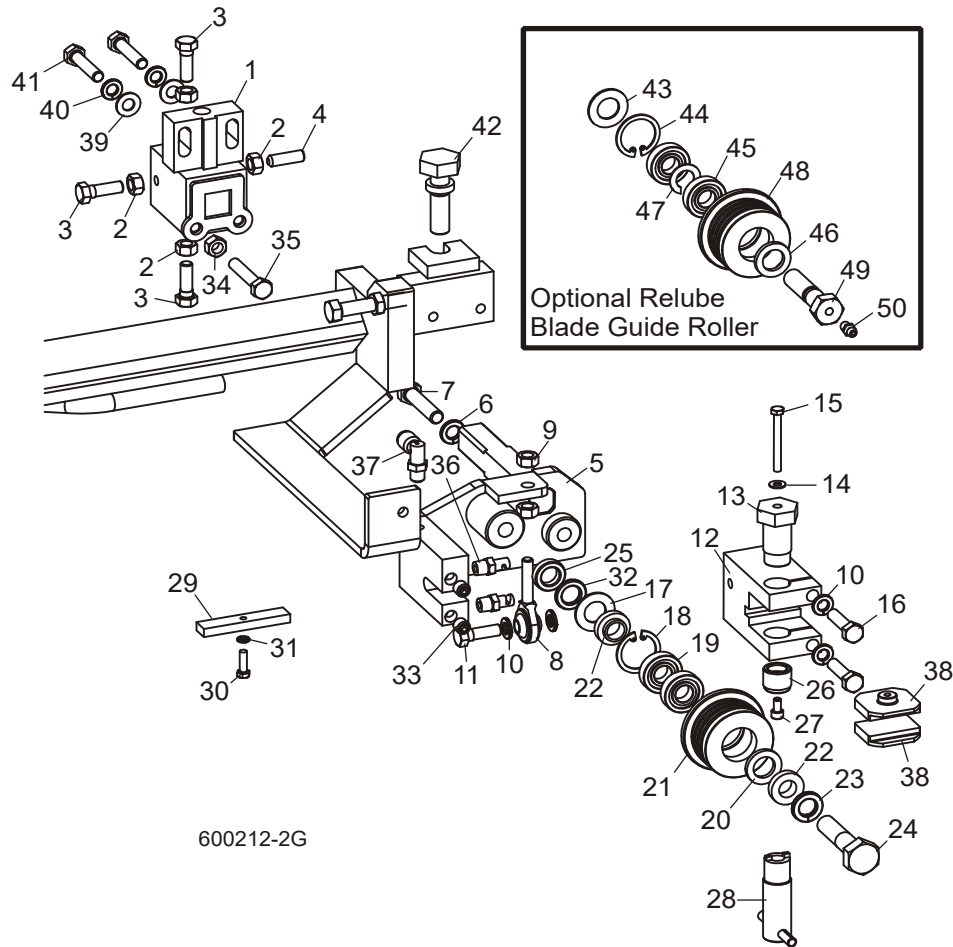

REF	DESCRIPTION (◆ Indicates Parts Available In Assemblies Only)	PART #	QTY.	
	ROLLER/BLOCK ASSEMBLY, IDLE SIDE (OUTER)	036818	1	
	Block Assembly, Blade Guide Mount	036872	1	
1	Block Weldment, Blade Guide Mount	036868	1	◆
2	Nut, 5/16-18 Hex	F05010-17	4	
3	Bolt, 5/16-18 x 1" Hex Head Stainless Steel	F05006-88	3	
4	Screw, 5/16-18 x 1" Socket Head Flat Point Stainless Steel Set	F05006-122	1	
5	Shaft Weldment, Idle Side Guide	036866	1	
6	Washer, 3/8" Split Lock	F05011-4	1	
7	Bolt, 3/8-16 x 1 3/4" Full Thread Hex Head Grade 5	F05007-129	1	
8	Rod End, 5/16-24 Male	P09814	1	
9	Nut, 5/16-24 Hex Jam	F05010-28	2	
10	Washer, 5/16" Split Lock	F05011-13	4	
11	Bolt, 5/16-18 x 1" Hex Head Stainless Steel	F05006-88	1	

Blade Guide Rollers & Arm

Blade Guide Assembly, Idle Side

2

12	Block, Guide Block Mount	036814	1	
13	Bolt, Blade Guide Block Mount	035216	1	
14	Washer, #10 Brass	042867	1	
15	Bolt, #10-32 x 1 3/4" Hex Head Stainless Steel	F05004-178	1	
16	Bolt, 5/16-18 x 1 1/4" Hex Head Stainless Steel	F05006-118	2	
	Roller Assembly, Blade Guide (standard for use with 1 1/4" & 1 1/2" blades)	A04925 ²	1	
	Roller Assembly, Extended Blade Guide (optional for use with 1 1/2" blades)	O14299 ²	1	
	Bearing Kit, Blade Guide Rebuild	K07079	1	
17	Washer, 5/8" White Felt	P04252	1	
18	Ring, 1 1/8" Interior Retaining	F04254-1	1	
19	Bearing, R8-2RS Blade Guide	O15975	2	◆
20	Washer, 5/8" Gray Felt	P06455	1	
	Screw, 1/4-28 x 1/4" Socket Head Cup Point Set Black Oxide	F05005-105	1	
	Instruction Sheet, Blade Guide Rebuild	057407-1507	1	
21	Roller, Flanged Blade Guide (1 1/4" & 1 1/2" blade)	S04250	1	◆
	Roller, Flanged Blade Guide (1 1/2" blade)	O14243	1	◆
	Instruction Sheet, Blade Guide Roller Replacement	A04925-364	1	
22	Spacer, Blade Guide	S04253	2	
23	Washer, 1/2" Split Lock	F05011-9 ³	1	
24	Bolt, 1/2-13 x 2 1/4" Hex Head Grade 5	F05008-10	1	
25	Spacer, 1/2" ID x 7/8" OD x 1/4" (For use with 1 1/4" Blades)	O41626 ⁴	1	
26	Screw, Lower Block Adjustment	O44057	1	
27	Screw, #10-32 x 3/8" Socket Head Stainless Steel	F05004-200	1	
28	Tool, Lower Block Adjustment	O44064	1	
29	Block, Blade Guide Alignment	O35799	1	
30	Screw, #10-32 x 5/8" Hex Head	F05004-152	1	
31	Washer, #10 Split Lock	F05011-20	1	
32	Spacer, 1/2" ID x 7/8" OD x 1/8" Thick	O52364 ⁴	1	
33	Fitting, 1/8" NPT Socket Pipe Plug	P30127	2	
34	Nut, 5/16-18 Hex	F05010-17	1	
35	Bolt, 5/16-18 x 1 3/4" Hex Head Full Thread	F05006-17	1	
36	FITTING, BLADE LUBE SPRAY NOZZLE	O33479 ⁵	2	
37	FITTING, 1/8" MPT X 1/4" TUBE SWIVEL ELBOW	P09736 ⁵	1	
38	BLOCK, BLADE GUIDE WEAR (STANDARD FOR 1 1/2" BLADES)	O52309 ⁶	2	
	BLOCK, BLADE GUIDE WEAR (OPTIONAL FOR 1 1/4" BLADES)	O52355 ⁵	2	
	BLOCK ASSEMBLY, 1" SQ. EZ-GLIDE WEAR	O36347 ⁵	2	
	SHIM, .008" BLADE GUIDE BLOCK SPACER	O35248	1	
39	WASHER, 5/16" SAE FLAT	F05011-17	2	
40	WASHER, 5/16" SPLIT LOCK	F05011-13	2	
41	BOLT, 5/16-18 X 1 1/2" HEX HEAD GRADE 5 FULL THREAD	F05006-76	2	
42	BOLT, BLADE GUIDE VERTICAL ADJUSTMENT	O35656	1	

2

Blade Guide Rollers & Arm

Blade Guide Assembly, Idle Side

	ROLLER ASSEMBLY, BLADE GUIDE RELUBE (OPTIONAL FOR USE WITH 1 1/4" & 1 1/2" BLADES)	016568 ²	1	
	ROLLER ASSEMBLY, EXTENDED BLADE GUIDE RELUBE (OPTIONAL FOR USE WITH 1 1/2" BLADES)	057405 ²	1	
	Bearing Kit, Relube Blade Guide Rebuild	057407	1	
43	Washer, 5/8" White Felt	P04252	1	
44	Ring, 1 1/8" Interior Retaining	F04254-1	1	
45	Bearing, R8-2RS Blade Guide (modified)	015975 ⁷	2	◆
46	Washer, 5/8" Gray Felt	P06455	1	
47	Spacer, Blade Guide Bearing	035411	1	
	Instruction Sheet, Blade Guide Rebuild	057407-1507	1	
48	Roller, Flanged Blade Guide (Relube 1 1/4" & 1 1/2" blade)	035426	1	◆
	Roller, Flanged Blade Guide (Relube 1 1/2" blade)	057402	1	◆
	Instruction Sheet, Blade Guide Roller Replacement	A04925-364	1	
49	BOLT, BLADE GUIDE ROLLER (RELUBE ONLY)	036161	1	
50	FITTING, 1/4-28 GREASE (RELUBE ONLY)	P05060	1	

² The sawmill is equipped standard with non-greasable blade guide rollers that can be used with the standard 1 1/2" blade. The roller can also be used with 1 1/4" blades (requires spacer 041626 & wear blocks 052355). Optional extended blade guide rollers are available for use with 1 1/2" blades. The extended rollers may provide more stability during difficult sawing, but will reduce the total amount of times the blade can be reused after sharpening. Optional relube versions of each roller configuration are also available.

³ Nord-Lock Washer F05011-125 available to replace Split Lock Washer F05011-9 to prevent loosening due to vibration (12/09).

⁴ Use 1/8" spacer 052364 with 1 1/2" blade provided as standard equipment. Use 1/4" spacer 041626 for optional 1 1/4" blades.

⁵ Fittings removed from blade guide assembly BOM to allow structuring of blade guide assembly in various equipment (11/05).

⁶ 052309 blocks for use with 1 1/2" blade provided as standard equipment. 052355 blocks available for optional use with 1 1/4" blades. EZ-Glide blocks 036347 are available for customers who prefer this block. Blocks removed from blade guide assembly BOM to allow structuring of blade guide assembly in various equipment (11/05).

⁷ Bearing must be modified for use with relube roller assemblies. Remove one seal from each bearing, place open sides facing each other and place spacer 035411 between bearings.

2.3 Blade Guide Assembly, Idle Side

LT60HD/70HD

Rev. A3.01 - A7.01

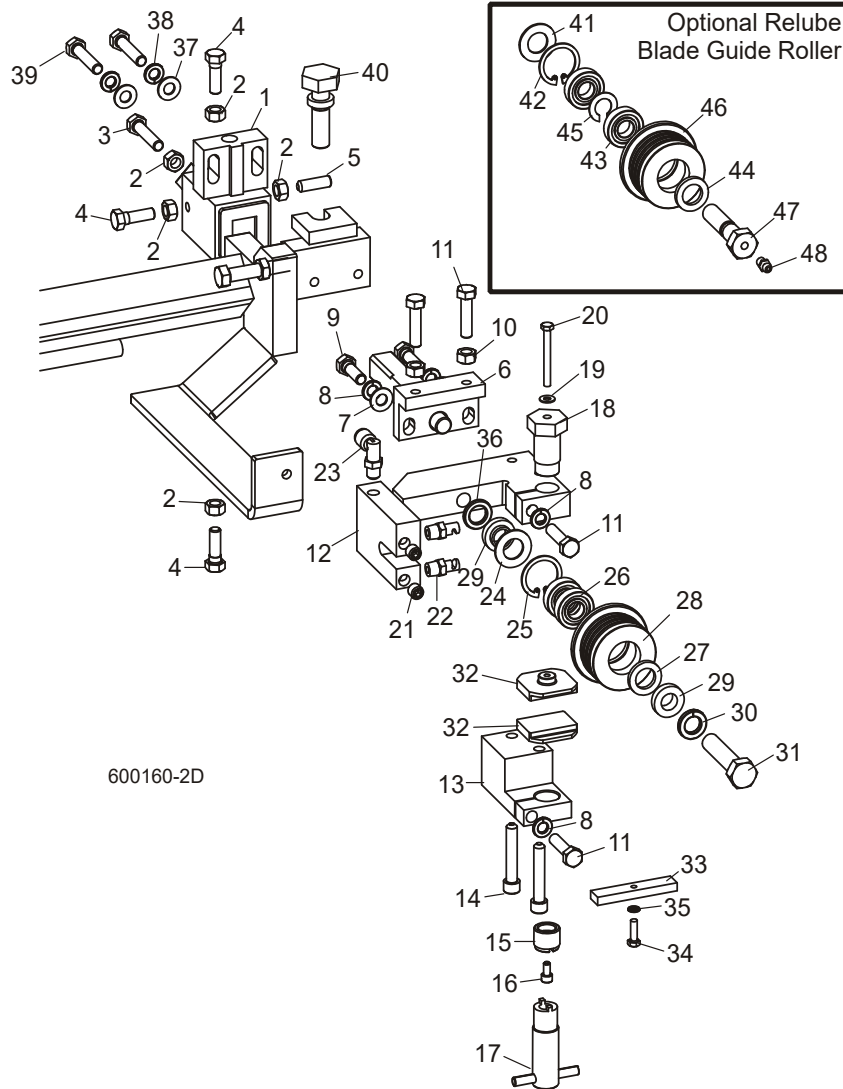

REF	DESCRIPTION (◆ Indicates Parts Available In Assemblies Only)	PART #	QTY.	
	GUIDE ASSEMBLY, IDLE SIDE BLOCK/ROLLER	044055 ¹	1	◆
	Block Assembly, Idle Side Blade Guide	036099	1	
1	Block Weldment, Blade Guide Mount	035219	1	◆
2	Nut, 5/16-18 Hex	F05010-17	5	
3	Bolt, 5/16-18 x 1 1/2" Hex Head Full Thread Stainless Steel	F05006-119	1	
4	Bolt, 5/16-18 x 1" Hex Head Stainless Steel	F05006-88	3	
5	Screw, 5/16-18 x 1" Socket Head Flat Point Stainless Steel	F05006-122	1	
6	Shaft Weldment, Block Guide Pivot	035209	1	
7	Washer, 5/16" SAE Flat	F05011-17	2	

2

Blade Guide Rollers & Arm*Blade Guide Assembly, Idle Side*

8	Washer, 5/16" Split Lock	F05011-13	4	
9	Bolt, 5/16-18 x 1" Hex Head Stainless Steel	F05006-88	2	
10	Nut, 5/16-18 Hex	F05010-17	2	
11	Bolt, 5/16-18 x 1 1/4" Hex Head Stainless Steel	F05006-118	4	
12	Block Weldment, Upper Blade Guide	044054	1	
13	Block, Lower Blade Guide	044053	1	
14	Screw, 5/16-18 x 1 3/4" Socket Head	F05006-65	2	
15	Screw, Lower Block Adjustment	044057	1	
16	Screw, #10-32 x 3/8" Socket Head Stainless Steel	F05004-200	1	
17	Tool, Lower Block Adjustment	044064	1	
18	Bolt, Blade Guide Block Mount	035216	1	
19	Washer, #10 Brass	042867	1	
20	Bolt, #10-32 x 1 3/4" Hex Head Stainless Steel	F05004-178	1	
21	Fitting, 1/8" NPT Socket Pipe Plug	P30127	2	
22	Fitting, Blade Lube Spray Nozzle	033479	2	
23	Fitting, 1/8" MPT x 1/4" Tube Swivel Elbow	P09736	1	
	Roller Assembly, Blade Guide (standard for use with 1 1/4" & 1 1/2" blades)	A04925 ²	1	
	Roller Assembly, Extended Blade Guide (optional for use with 1 1/2" blades)	014299 ²	1	
	Bearing Kit, Blade Guide Rebuild	K07079	1	
24	Washer, 5/8" White Felt	P04252	1	
25	Ring, 1 1/8" Interior Retaining	F04254-1	1	
26	Bearing, R8-2RS Blade Guide	015975	2	◆
27	Washer, 5/8" Gray Felt	P06455	1	
	Screw, 1/4-28 x 1/4" Socket Head Cup Point Set Black Oxide	F05005-105	1	
	Instruction Sheet, Blade Guide Rebuild	057407-1507	1	
28	Roller, Flanged Blade Guide (1 1/4" & 1 1/2" blade)	S04250	1	◆
	Roller, Flanged Blade Guide (1 1/2" blade)	014243	1	◆
	Instruction Sheet, Blade Guide Roller Replacement	A04925-364	1	
29	Spacer, Blade Guide	S04253	2	
30	Washer, 1/2" Split Lock	F05011-9 ³	1	
31	Bolt, Blade Guide Roller	036399	1	
32	Block, Blade Guide Wear (Standard for 1 1/2" Blades)	052309 ⁴	2	
	Block, Blade Guide Wear (Optional for 1 1/4" Blades)	052355 ⁴	2	
	Block Assembly, 1" Sq. EZ-Glide Wear	036347 ⁴	2	
33	Block, Blade Guide Alignment	035799	1	
34	Screw, #10-32 x 5/8" Hex Head	F05004-152	1	
35	Washer, #10 Split Lock	F05011-20	1	
36	Spacer, 1/2" ID x 7/8" OD x 1/8" Thick (For use with 1 1/4" Blades)	052364 ⁵	1	
	SHIM, .008" BLADE GUIDE BLOCK SPACER	035248	1	
37	WASHER, 5/16" SAE FLAT	F05011-17	2	
38	WASHER, 5/16" SPLIT LOCK	F05011-13	2	
39	BOLT, 5/16-18 X 1 1/2" HEX HEAD GRADE 5 FULL THREAD	F05006-76	2	

40	BOLT, BLADE GUIDE VERTICAL ADJUSTMENT	035656	1	
	ROLLER ASSEMBLY, BLADE GUIDE RELUBE (OPTIONAL FOR USE WITH 1 1/4" & 1 1/2" BLADES)	016568 ²	1	
	ROLLER ASSEMBLY, EXTENDED BLADE GUIDE RELUBE (OPTIONAL FOR USE WITH 1 1/2" BLADES)	057405 ²	1	
	Bearing Kit, Relube Blade Guide Rebuild	057407	1	
41	Washer, 5/8" White Felt	P04252	1	
42	Ring, 1 1/8" Interior Retaining	F04254-1	1	
43	Bearing, R8-2RS Blade Guide (modified)	015975 ⁶	2	◆
44	Washer, 5/8" Gray Felt	P06455	1	
45	Spacer, Blade Guide Bearing	035411	1	
	Instruction Sheet, Blade Guide Rebuild	057407-1507	1	
46	Roller, Flanged Blade Guide (Relube 1 1/4" & 1 1/2" blade)	035426	1	◆
	Roller, Flanged Blade Guide (Relube 1 1/2" blade)	057402	1	◆
	Instruction Sheet, Blade Guide Roller Replacement	A04925-364	1	
47	BOLT, BLADE GUIDE ROLLER (RELUBE ONLY)	036161	1	
48	FITTING, 1/4-28 GREASE (RELUBE ONLY)	P05060	1	

¹ 044055 Blade Guide Assembly replaced with 036818 Rev. A7.02 then 003926 Rev. A8.01 and no longer available. Use component parts to service or replace entire assembly with 003926. New assembly provides easier adjustment ([See Section 2.1](#))

² The sawmill is equipped standard with non-greasable blade guide rollers that can be used with the standard 1 1/2" blade. The roller can also be used with 1 1/4" blades. Optional extended blade guide rollers are available for use with 1 1/2" blades. The extended rollers may provide more stability during difficult sawing, but will reduce the total amount of times the blade can be reused after sharpening. Optional relube versions of each roller configuration are also available.

³ Nord-Lock Washer F05011-125 available to replace Split Lock Washer F05011-9 to prevent loosening due to vibration (12/09).

⁴ Blade guide wear blocks 052309 & 052355 replace EZ-Glide block 036347 to improve wear life (Rev. A6.01). 052309 blocks for use with 1 1/2" blade provided as standard equipment. 052355 blocks available for optional use with 1 1/4" blades. EZ-Glide blocks 036347 are available for customers who prefer this block.

⁵ 1/8" thick spacer 052364 replaces 1/4" spacer 041626 to provide proper spacing of blade guide block when using 1 1/4" blades.

⁶ Bearing must be modified for use with relube roller assemblies. Remove one seal from each bearing, place open sides facing each other and place spacer 035411 between bearings.

2 Blade Guide Rollers & Arm

Blade Guide Assembly, Drive Side

2.4 Blade Guide Assembly, Drive Side

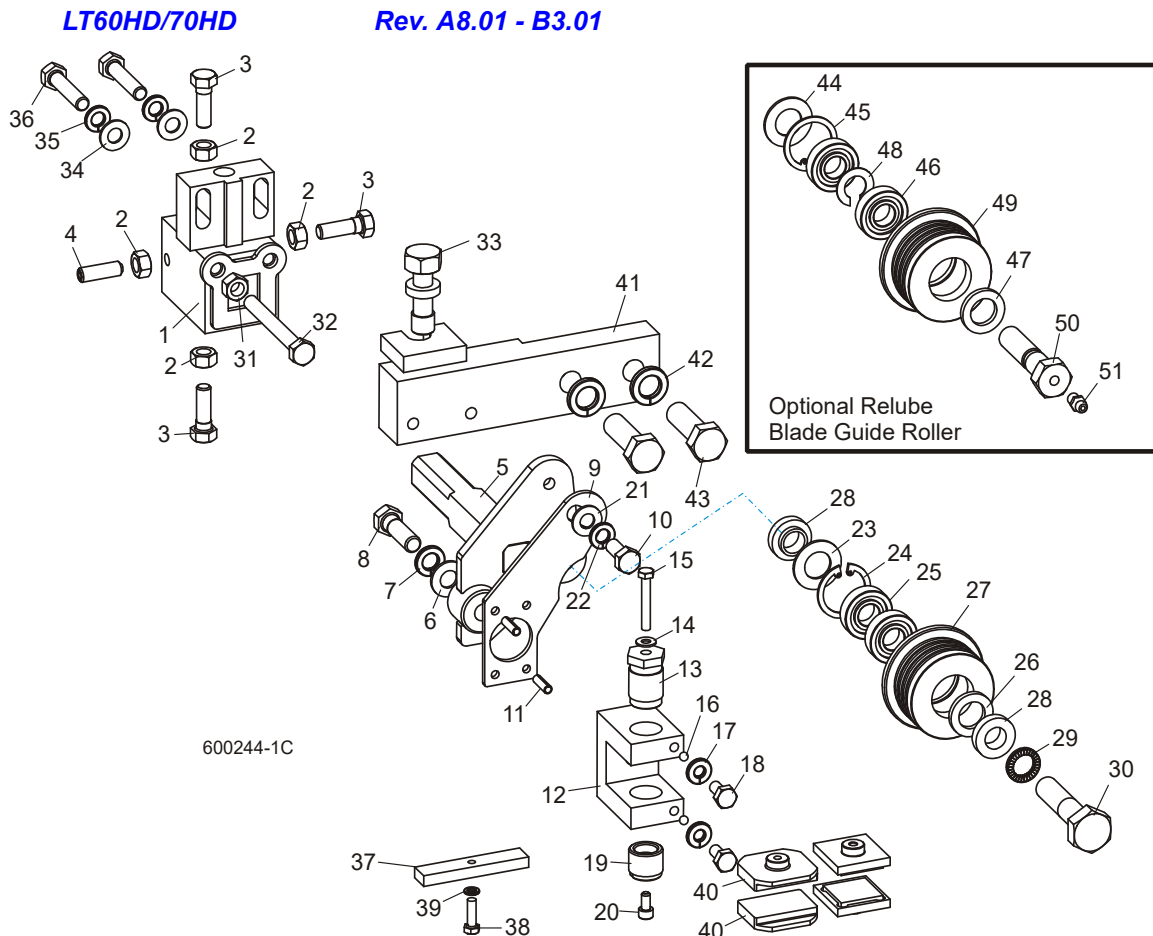

REF	DESCRIPTION (◆ Indicates Parts Available In Assemblies Only)	PART #	QTY.
	ROLLER/BLOCK ASSEMBLY, DRIVE SIDE (INNER)	003925 ¹	1
	Block Assembly, Blade Guide Mount	003910	1
1	Block Weldment, Blade Guide Mount	003911	1 ◆
2	Nut, 5/16-18 Hex	F05010-17	4
3	Bolt, 5/16-18 x 1" Hex Head Stainless Steel	F05006-88	3
4	Screw, 5/16-18 x 1" Socket Head Flat Point Stainless Steel Set	F05006-122	1
5	Shaft Weldment, Drive Side Guide	003913	1
	Mount Assembly, Blade Guide Block Drive	003927	1
6	Washer, 3/8" SAE Flat	F05011-3	1
7	Washer, 3/8" Split Lock	F05011-4	1
8	Bolt, 3/8-16 x 1 1/4" Hex Head Grade 5	F05007-123	1
9	Plate, Block Tilt Adjustment	003915	1
10	Bolt, 5/16-18 x 3/4" Hex Head	F05006-102	1
11	Pin, 3/16" x 5/8" Roll	F05012-22	2

Blade Guide Rollers & Arm

Blade Guide Assembly, Drive Side

2

12	Block, Guide Block Mount	003909	1	
13	Bolt, Blade Guide Block Mount	003994	1	
14	Washer, #10 Brass	042867	1	
15	Bolt, #10-32 x 1 1/4" Hex Head Stainless Steel	F05004-240	1	
16	Ball, 3/16" Dia. Nylon	003914	2	
17	Washer, 1/4" Split Lock	F05011-14	2	
18	Bolt, 1/4-20 x 1/2" Hex Head	F05005-15	2	
19	Screw, Lower Block Adjustment	044057	1	
20	Screw, #10-32 x 3/8" Socket Head Stainless Steel	F05004-200	1	
21	Washer, 5/16" SAE Flat	F05011-17	1	
22	Washer, 5/16" Split Lock	F05011-13	1	
	Roller Assembly, Blade Guide (standard for use with 1 1/4" & 1 1/2" blades)	A04925 ²	1	
	Roller Assembly, Extended Blade Guide (optional for use with 1 1/2" blades)	014299 ²	1	
	Bearing Kit, Blade Guide Rebuild	K07079	1	
23	Washer, 5/8" White Felt	P04252	1	
24	Ring, 1 1/8" Interior Retaining	F04254-1	1	
25	Bearing, R8-2RS Blade Guide	015975	2	◆
26	Washer, 5/8" Gray Felt	P06455	1	
	Screw, 1/4-28 x 1/4" Socket Head Cup Point Set Black Oxide	F05005-105	1	
	Instruction Sheet, Blade Guide Rebuild	057407-1507	1	
27	Roller, Flanged Blade Guide (1 1/4" & 1 1/2" blade)	S04250	1	◆
	Roller, Flanged Blade Guide (1 1/2" blade)	014243	1	◆
	Instruction Sheet, Blade Guide Roller Replacement	A04925-364	1	
28	Spacer, Blade Guide	S04253	2	
29	Washer, 1/2" Nord-Lock	F05011-125 ³	1	
30	Bolt, 1/2-13 x 2 1/4" Hex Head Grade 5	F05008-10	1	
31	Nut, 5/16-18 Hex	F05010-17	1	
32	Bolt, 5/16-18 x 2 3/4" Hex Head Full Thread	F05006-136	1	
33	Bolt, Blade Guide Vertical Adjustment	035656	1	
34	Washer, 5/16" SAE Flat	F05011-17	2	
35	Washer, 5/16" Split Lock	F05011-13	2	
36	Bolt, 5/16-18 x 1 1/2" Hex Head	F05006-76	2	
37	BLOCK, BLADE GUIDE ALIGNMENT	035799	1	
38	SCREW, #10-32 X 5/8" HEX HEAD	F05004-152	1	
39	WASHER, #10 SPLIT LOCK	F05011-20	1	
40	BLOCK, BLADE GUIDE WEAR (STANDARD FOR 1 1/2" BLADES)	052309 ⁴	2	
	BLOCK, BLADE GUIDE WEAR (OPTIONAL FOR 1 1/4" BLADES)	052355 ⁴	2	
	BLOCK ASSEMBLY, 1" SQ. EZ-GLIDE WEAR	036347 ⁴	2	
41	ARM WELDMENT, DRIVE SIDE BLADE GUIDE	034292	1	
42	WASHER, 1/2" SPLIT LOCK	F05011-9	2	
43	BOLT, 1/2-13 X 1 1/2" HEX HEAD GRADE 5	F05008-33	2	
	SHIM, .008" BLADE GUIDE BLOCK SPACER	035248	1	

2

Blade Guide Rollers & Arm

Blade Guide Assembly, Drive Side

	ROLLER ASSEMBLY, BLADE GUIDE RELUBE (OPTIONAL FOR USE WITH 1 1/4" & 1 1/2" BLADES)	016568 ²	1	
	ROLLER ASSEMBLY, EXTENDED BLADE GUIDE RELUBE (OPTIONAL FOR USE WITH 1 1/2" BLADES)	057405 ²	1	
	Bearing Kit, Relube Blade Guide Rebuild	057407	1	
44	Washer, 5/8" White Felt	P04252	1	
45	Ring, 1 1/8" Interior Retaining	F04254-1	1	
46	Bearing, R8-2RS Blade Guide	015975 ⁵	2	◆
47	Washer, 5/8" Gray Felt	P06455	1	
48	Spacer, Blade Guide Bearing	035411	1	
	Instruction Sheet, Blade Guide Rebuild	057407-1507	1	
49	Roller, Flanged Blade Guide (Relube 1 1/4" & 1 1/2" blade)	035426	1	◆
	Roller, Flanged Blade Guide (Relube 1 1/2" blade)	057402	1	◆
	Instruction Sheet, Blade Guide Roller Replacement	A04925-364	1	
50	BOLT, BLADE GUIDE ROLLER (RELUBE ONLY)	036161	1	
51	FITTING, 1/4-28 GREASE (RELUBE ONLY)	P05060	1	

¹ Roller/Block Assembly 003925 is no longer available. Use component parts to service or order Roller/Block Assembly 036812 for 1-1/4" blades or 065933 for 1-1/2" blades.

² The sawmill is equipped standard with non-greasable blade guide rollers that can be used with the standard 1 1/2" blade. The roller can also be used with 1 1/4" blades. Optional extended blade guide rollers are available for use with 1 1/2" blades. The extended rollers may provide more stability during difficult sawing, but will reduce the total amount of times the blade can be reused after sharpening. Optional relube versions of each roller configuration are also available.

³ Nord-Lock Washer F05011-125 replaced Split Lock Washer F05011-9 to prevent loosening due to vibration (Rev. B3.01).

⁴ 052309 blocks for use with 1 1/2" blade provided as standard equipment. 052355 blocks available for optional use with 1 1/4" blades. EZ-Glide blocks 036347 are available for customers who prefer this block.

⁵ Bearing must be modified for use with relube roller assemblies. Remove one seal from each bearing, place open sides facing each other and place spacer 035411 between bearings.

2.5 Blade Guide Assembly, Drive Side

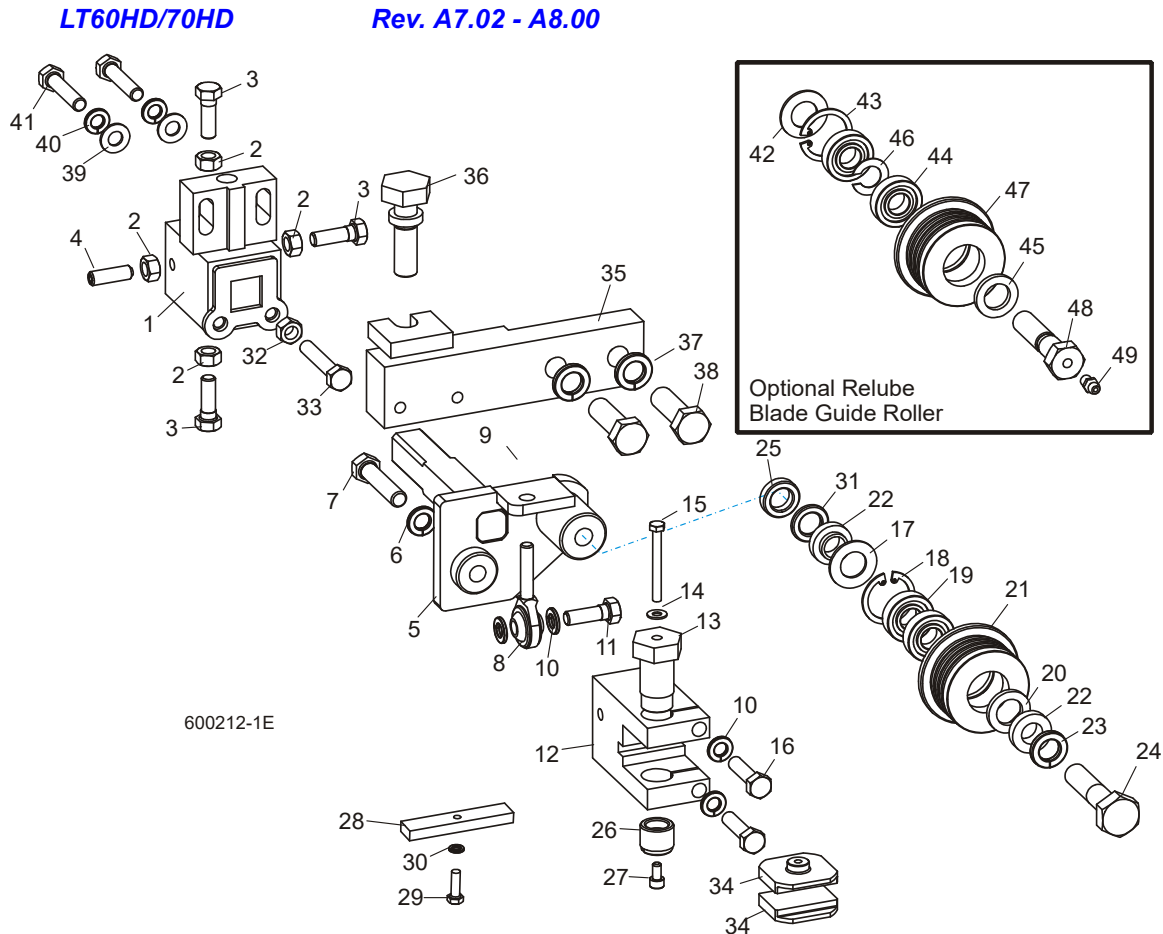

REF	DESCRIPTION (◆ Indicates Parts Available In Assemblies Only)	PART #	QTY.	
	ROLLER/BLOCK ASSEMBLY, DRIVE SIDE (INNER)	036812	1	
	Block Assembly, Blade Guide Mount	036867	1	
1	Block Weldment, Blade Guide Mount	036868	1	◆
2	Nut, 5/16-18 Hex	F05010-17	4	
3	Bolt, 5/16-18 x 1" Hex Head Stainless Steel	F05006-88	3	
4	Screw, 5/16-18 x 1" Socket Head Flat Point Stainless Steel Set	F05006-122	1	
5	Shaft Weldment, Drive Side Guide	036865	1	
6	Washer, 3/8" Split Lock	F05011-4	1	
7	Bolt, 3/8-16 x 1 3/4" Full Thread Hex Head Grade 5	F05007-129	1	
8	Rod End, 5/16-24 Male	P09814	1	
9	Nut, 5/16-24 Hex Jam	F05010-28	2	
10	Washer, 5/16" Split Lock	F05011-13	4	
11	Bolt, 5/16-18 x 1" Hex Head Stainless Steel	F05006-88	1	
12	Block, Guide Block Mount	036814	1	

2

Blade Guide Rollers & Arm

Blade Guide Assembly, Drive Side

13	Bolt, Blade Guide Block Mount	035216	1	
14	Washer, #10 Brass	042867	1	
15	Bolt, #10-32 x 1 3/4" Hex Head Stainless Steel	F05004-178	1	
16	Bolt, 5/16-18 x 1 1/4" Hex Head Stainless Steel	F05006-118	2	
	Roller Assembly, Blade Guide (standard for use with 1 1/4" & 1 1/2" blades)	A04925 ²	1	
	Roller Assembly, Extended Blade Guide (optional for use with 1 1/2" blades)	014299 ¹	1	
	Bearing Kit, Blade Guide Rebuild	K07079	1	
17	Washer, 5/8" White Felt	P04252	1	
18	Ring, 1 1/8" Interior Retaining	F04254-1	1	
19	Bearing, R8-2RS Blade Guide	015975	2	◆
20	Washer, 5/8" Gray Felt	P06455	1	
	Screw, 1/4-28 x 1/4" Socket Head Cup Point Set Black Oxide	F05005-105	1	
	Instruction Sheet, Blade Guide Rebuild	057407-1507	1	
21	Roller, Flanged Blade Guide (1 1/4" & 1 1/2" blade)	S04250	1	◆
	Roller, Flanged Blade Guide (1 1/2" blade)	014243	1	◆
	Instruction Sheet, Blade Guide Roller Replacement	A04925-364	1	
22	Spacer, Blade Guide	S04253	2	
23	Washer, 1/2" Split Lock	F05011-9 ³	1	
24	Bolt, 1/2-13 x 2 1/4" Hex Head Grade 5	F05008-10	1	
25	Spacer, 1/2" ID x 7/8" OD x 1/4" (for use with 1 1/4" Blades Only)	041626 ⁴	1	
26	Screw, Lower Block Adjustment	044057	1	
27	Screw, #10-32 x 3/8" Socket Head Stainless Steel	F05004-200	1	
28	Block, Blade Guide Alignment	035799	1	
29	Screw, #10-32 x 5/8" Hex Head	F05004-152	1	
30	Washer, #10 Split Lock	F05011-20	1	
31	Spacer, 1/2" ID x 7/8" OD x 1/8" Thick	052364 ⁴	1	
32	Nut, 5/16-18 Hex	F05010-17	1	
33	Bolt, 5/16-18 x 1 3/4" Hex Head Full Thread	F05006-17	1	
34	BLOCK, BLADE GUIDE WEAR (STANDARD FOR 1 1/2" BLADES)	052309 ⁵	2	
	BLOCK, BLADE GUIDE WEAR (OPTIONAL FOR 1 1/4" BLADES)	052355 ⁵	2	
	BLOCK ASSEMBLY, 1" SQ. EZ-GLIDE WEAR	036347 ⁵	2	
35	ARM WELDMENT, DRIVE SIDE BLADE GUIDE	034292	1	
36	BOLT, BLADE GUIDE VERTICAL ADJUSTMENT	035656	1	
37	WASHER, 1/2" SPLIT LOCK	F05011-9	2	
38	BOLT, 1/2-13 X 1 1/2" HEX HEAD GRADE 5	F05008-33	2	
	SHIM, .008" BLADE GUIDE BLOCK SPACER	035248	1	
39	WASHER, 5/16" SAE FLAT	F05011-17	2	
40	WASHER, 5/16" SPLIT LOCK	F05011-13	2	
41	BOLT, 5/16-18 X 1 1/2" HEX HEAD STAINLESS STEEL	F05006-119	2	

	ROLLER ASSEMBLY, BLADE GUIDE RELUBE (OPTIONAL FOR USE WITH 1 1/4" & 1 1/2" BLADES)	016568 ¹	1	
	ROLLER ASSEMBLY, EXTENDED BLADE GUIDE RELUBE (OPTIONAL FOR USE WITH 1 1/2" BLADES)	057405 ¹	1	
	Bearing Kit, Relube Blade Guide Rebuild	057407	1	
42	Washer, 5/8" White Felt	P04252	1	
43	Ring, 1 1/8" Interior Retaining	F04254-1	1	
44	Bearing, R8-2RS Blade Guide	015975 ⁶	2	◆
45	Washer, 5/8" Gray Felt	P06455	1	
46	Spacer, Blade Guide Bearing	035411	1	
	Instruction Sheet, Blade Guide Rebuild	057407-1507	1	
47	Roller, Flanged Blade Guide (Relube 1 1/4" & 1 1/2" blade)	035426	1	◆
	Roller, Flanged Blade Guide (Relube 1 1/2" blade)	057402	1	◆
	Instruction Sheet, Blade Guide Roller Replacement	A04925-364	1	
48	BOLT, BLADE GUIDE ROLLER (RELUBE ONLY)	036161	1	
49	FITTING, 1/4-28 GREASE (RELUBE ONLY)	P05060	1	

² The sawmill is equipped standard with non-greasable blade guide rollers that can be used with the standard 1 1/2" blade (requires spacer 052364). The roller can also be used with 1 1/4" blades (requires spacer 041626 & wear blocks 052355). Optional extended blade guide rollers are available for use with 1 1/2" blades (no spacer required). The extended rollers may provide more stability during difficult sawing, but will reduce the total amount of times the blade can be reused after sharpening. Optional relube versions of each roller configuration are also available.

³ Nord-Lock Washer F05011-125 available to replace Split Lock Washer F05011-9 to prevent loosening due to vibration (12/09).

⁴ Use 1/8" spacer 052364 with 1 1/2" blade provided as standard equipment. Use 1/4" spacer 041626 for optional 1 1/4" blades.

⁵ 052309 blocks for use with 1 1/2" blade provided as standard equipment. 052355 blocks available for optional use with 1 1/4" blades. EZ-Glide blocks 036347 are available for customers who prefer this block. Blocks removed from blade guide assembly BOM to allow structuring of blade guide assembly in various equipment (11/05).

⁶ Bearing must be modified for use with relube roller assemblies. Remove one seal from each bearing, place open sides facing each other and place spacer 035411 between bearings.

2 Blade Guide Rollers & Arm

Blade Guide Assembly, Drive Side

2.6 Blade Guide Assembly, Drive Side

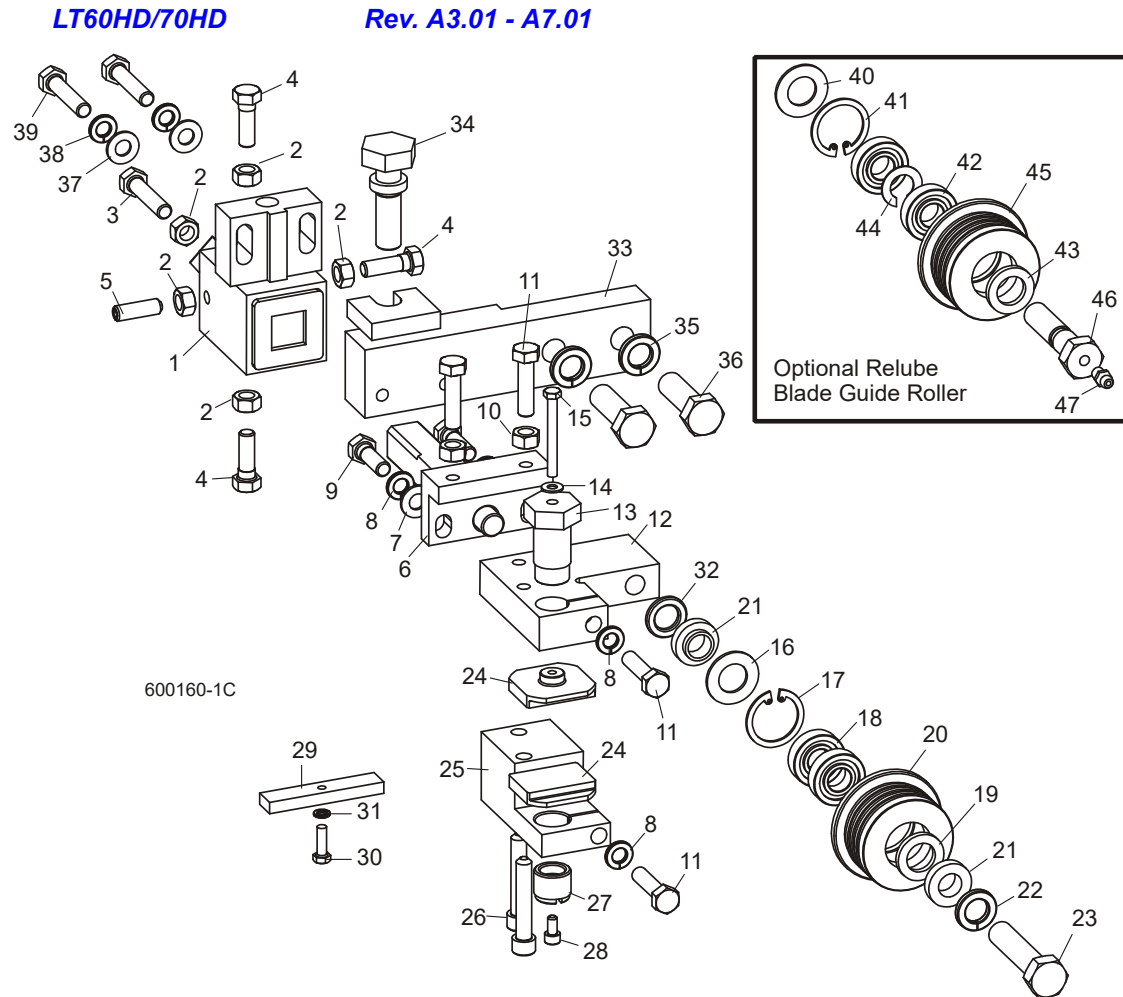

REF	DESCRIPTION (◆ Indicates Parts Available In Assemblies Only)	PART #	QTY.	
	ROLLER/BLOCK ASSEMBLY, DRIVE SIDE (INNER)	044050 ¹	1	◆
	Block Assembly, Blade Guide Mount	036100	1	
1	Block Weldment, Blade Guide Mount	035219	1	◆
2	Nut, 5/16-18 Hex	F05010-17	5	
3	Bolt, 5/16-18 x 1 1/2" Hex Head Full Thread Stainless Steel	F05006-119	1	
4	Bolt, 5/16-18 x 1" Hex Head Stainless Steel	F05006-88	3	
5	Screw, 5/16-18 x 1" Socket Head Flat Point Stainless Steel Set	F05006-122	1	
6	Shaft Weldment, Block Guide Pivot	035209	1	
7	Washer, 5/16" SAE Flat	F05011-17	2	
8	Washer, 5/16" Split Lock	F05011-13	4	
9	Bolt, 5/16-18 x 1" Hex Head Stainless Steel	F05006-88	2	
10	Nut, 5/16-18 Hex	F05010-17	2	

Blade Guide Rollers & Arm

Blade Guide Assembly, Drive Side

2

11	Bolt, 5/16-18 x 1 1/4" Hex Head Stainless Steel	F05006-118	4	
12	Block, Upper Blade Guide	044051	1	
13	Bolt, Blade Guide Block Mount	035216	1	
14	Washer, #10 Brass	042867	1	
15	Bolt, #10-32 x 1 3/4" Hex Head Stainless Steel	F05004-178	1	
	Roller Assembly, Blade Guide (standard for use with 1 1/4" & 1 1/2" blades)	A04925 ²	1	
	Roller Assembly, Extended Blade Guide (optional for use with 1 1/2" blades)	014299 ²	1	
	Bearing Kit, Blade Guide Rebuild	K07079	1	
16	Washer, 5/8" White Felt	P04252	1	
17	Ring, 1 1/8" Interior Retaining	F04254-1	1	
18	Bearing, R8-2RS Blade Guide	015975	2	◆
19	Washer, 5/8" Gray Felt	P06455	1	
	Screw, 1/4-28 x 1/4" Socket Head Cup Point Set Black Oxide	F05005-105	1	
	Instruction Sheet, Blade Guide Rebuild	057407-1507	1	
20	Roller, Flanged Blade Guide (1 1/4" & 1 1/2" blade)	S04250	1	◆
	Roller, Flanged Blade Guide (1 1/2" blade)	014243	1	◆
	Instruction Sheet, Blade Guide Roller Replacement	A04925-364	1	
21	Spacer, Blade Guide	S04253	2	
22	Washer, 1/2" Split Lock	F05011-9 ³	1	
23	Bolt, 1/2-13 x 2 1/4" Hex Head Grade 5	F05008-10	1	
24	Block, Blade Guide Wear (Standard for 1 1/2" Blades)	052309 ⁴	2	
	Block, Blade Guide Wear (Optional for 1 1/4" Blades)	052355 ⁴	2	
	Block Assembly, 1" Sq. EZ-Glide Wear	036347 ⁴	2	
25	Block, Lower Blade Guide	044052	1	
26	Screw, 5/16-18 x 1 3/4" Socket Head	F05006-65	2	
27	Screw, Lower Block Adjustment	044057	1	
28	Screw, #10-32 x 3/8" Socket Head Stainless Steel	F05004-200	1	
29	Block, Blade Guide Alignment	035799	1	
30	Screw, #10-32 x 5/8" Hex Head	F05004-152	1	
31	Washer, #10 Split Lock	F05011-20	1	
32	Spacer, 1/2" ID x 7/8" OD x 1/8" Thick (For use with 1 1/4" Blades)	052364 ⁵	1	
33	ARM WELDMENT, DRIVE SIDE BLADE GUIDE	034292	1	
34	BOLT, BLADE GUIDE VERTICAL ADJUSTMENT	035656	1	
35	WASHER, 1/2" SPLIT LOCK	F05011-9	2	
36	BOLT, 1/2-13 X 1 1/2" HEX HEAD GRADE 5	F05008-33	2	
	SHIM, .008" BLADE GUIDE BLOCK SPACER	035248	1	
37	WASHER, 5/16" SAE FLAT	F05011-17	2	
38	WASHER, 5/16" SPLIT LOCK	F05011-13	2	
39	BOLT, 5/16-18 X 1 1/2" HEX HEAD STAINLESS STEEL	F05006-119	2	
	ROLLER ASSEMBLY, BLADE GUIDE RELUBE (OPTIONAL FOR USE WITH 1 1/4" & 1 1/2" BLADES)	016568 ²	1	
	ROLLER ASSEMBLY, EXTENDED BLADE GUIDE RELUBE (OPTIONAL FOR USE WITH 1 1/2" BLADES)	057405 ²	1	

2

Blade Guide Rollers & Arm

Blade Guide Assembly, Drive Side

	Bearing Kit, Relube Blade Guide Rebuild	057407	1	
40	Washer, 5/8" White Felt	P04252	1	
41	Ring, 1 1/8" Interior Retaining	F04254-1	1	
42	Bearing, R8-2RS Blade Guide	015975 ⁶	2	◆
43	Washer, 5/8" Gray Felt	P06455	1	
44	Spacer, Blade Guide Bearing	035411	1	
	Instruction Sheet, Blade Guide Rebuild	057407-1507	1	
45	Roller, Flanged Blade Guide (Relube 1 1/4" & 1 1/2" blade)	035426	1	◆
	Roller, Flanged Blade Guide (Relube 1 1/2" blade)	057402	1	◆
	Instruction Sheet, Blade Guide Roller Replacement	A04925-364	1	
46	BOLT, BLADE GUIDE ROLLER (RELUBE ONLY)	036161	1	
47	FITTING, 1/4-28 GREASE (RELUBE ONLY)	P05060	1	

¹ 044050 Blade Guide Assembly replaced with 036812 Rev. A7.02 then 003925 Rev. A8.01 and no longer available. Use component parts to service or replace entire assembly with 003925. New assembly provides easier adjustment ([See Section 2.4](#)).

² The sawmill is equipped standard with non-greasable blade guide rollers that can be used with the standard 1 1/2" blade. The roller can also be used with 1 1/4" blades. Optional extended blade guide rollers are available for use with 1 1/2" blades. The extended rollers may provide more stability during difficult sawing, but will reduce the total amount of times the blade can be reused after sharpening. Optional relube versions of each roller configuration are also available.

³ Nord-Lock Washer F05011-125 available to replace Split Lock Washer F05011-9 to prevent loosening due to vibration (12/09).

⁴ Blade guide wear blocks 052309 & 052355 replace EZ-Glide block 036347 to improve wear life (Rev. A6.01). 052309 blocks for use with 1 1/2" blade provided as standard equipment. 052355 blocks available for optional use with 1 1/4" blades. EZ-Glide blocks 036347 are available for customers who prefer this block.

⁵ 1/8" thick spacer 052364 replaces 1/4" spacer 041626 to provide proper spacing of blade guide block when using 1 1/4" blades.

⁶ Bearing must be modified for use with relube roller assemblies. Remove one seal from each bearing, place open sides facing each other and place spacer 035411 between bearings.

2

Blade Guide Rollers & Arm

Blade Guide Arm Drive Assembly

	Gear Kit, Klauber Motor Replacement	P12569	1	
	Brush Kit, Gear Motor Replacement	P12800	1	
	Shaft Kit, Klauber Gear Motor Replacement	009695	1	
13	Sprocket Assembly, 25B14 x .3130	036664 ¹	1	
14	Screw, #10-24 x 1/4" Full Dog Point Socket Set	F05004-274	2	
15	Spacer, Blade Guide Arm V-Roller	033913	4	
	Roller Assembly, Blade Guide Arm V Idle	042543	2	
16	Housing, 2 1/2" V-Groove	042536	1	
17	Bearing, 5/8" x 1.7548" x .4724"	P06030-1	2	
18	Ring, 1.575" ID Beveled 5002-156 Retaining	F04254-8	1	
	Roller Assembly, Blade Guide Arm V Drive	042542	2	
19	Housing, 2 1/2" V-Groove w/Sprocket	042541	1	
20	Bearing, 5/8" x 1.7548" x .4724"	P06030-1	2	
21	Ring, 1.575" ID Beveled 5002-156 Retaining	F04254-8	1	
22	Arm Weldment, Blade Guide	034289	1	
23	Bolt, 5/8-18 x 2 1/4" Hex Head Grade 5	F05009-80	2	
24	Nut, 3/8-16 Hex Jam	F05010-29	2	
25	Bolt, 5/8-18 x 3 1/4" Hex Head Grade 5	F05009-98	2	
26	Nut, 5/8-18 Hex Nylon Lock	F05010-71	2	
27	Bolt, 1/2-20 x 2" Hex Head Full Thread	F05008-126	2	
28	Nut, 1/2-20 Hex Jam	F05010-16	2	
29	Washer, 5/16" SAE Flat	F05011-17	2	
30	Nut, 5/16-18 Hex Nylon Lock	F05010-58	1	
31	Bolt, 5/16-18 x 1 1/2" Hex Head Grade 5	F05008-96	1	
32	Washer, 3/4" Split Lock	F05011-6	1	
33	Bolt, 3/4-16 x 2" Full Thread Hex Head	F05013-1	1	
34	Guard, Blade Guide Arm	014955	1	
35	Nut, 1/4-20 Hex Nylon Lock	F05010-69	1	
36	Bracket, Blade Guide Arm Guide	014882	1	
37	Bolt, 5/16-18 x 1" Flat Head Socket	F05006-124 ²	1	
38	Nut, 5/16-18 Hex Lock	F05010-6	1	
39	Decal, Blade Guide Arm Warning Stripe	015849	1	
40	Screw, 1/4-20 x 1" Hex Head	F05005-38	1	
41	Bolt, 5/16-18 x 2 1/2" Hex Head Grade 5	F05006-80	2	
42	Chain, #25 x 27 3/4"	036194	1	
43	Link, #25 Master	P09983	2	
44	Cap, 2.5" ID x 3" Rubber	023720	1	
45	Nut, 3/8-16 Hex Jam	F05010-29	1	
46	Bolt, 3/8-16 x 2" Hex Head Full Thread	F05007-16	1	

¹ Sprocket modified 6/11 with threaded holes to accept included set screws (replace 1/8" x 3/4" roll pin F05012-6). 14 Tooth Sprocket 036664 replaces 13 Tooth Sprocket P09970 to improve speed of blade guide arm operation (Rev. A5.00).

² ¹ Bolt F05006-124 replaces 3/4" Bolt F05006-95 originally supplied before Rev. A6.00 to improve thread engagement.

SECTION 3 BLADE WHEELS & TENSIONER

3.1 Blade Drive Assembly

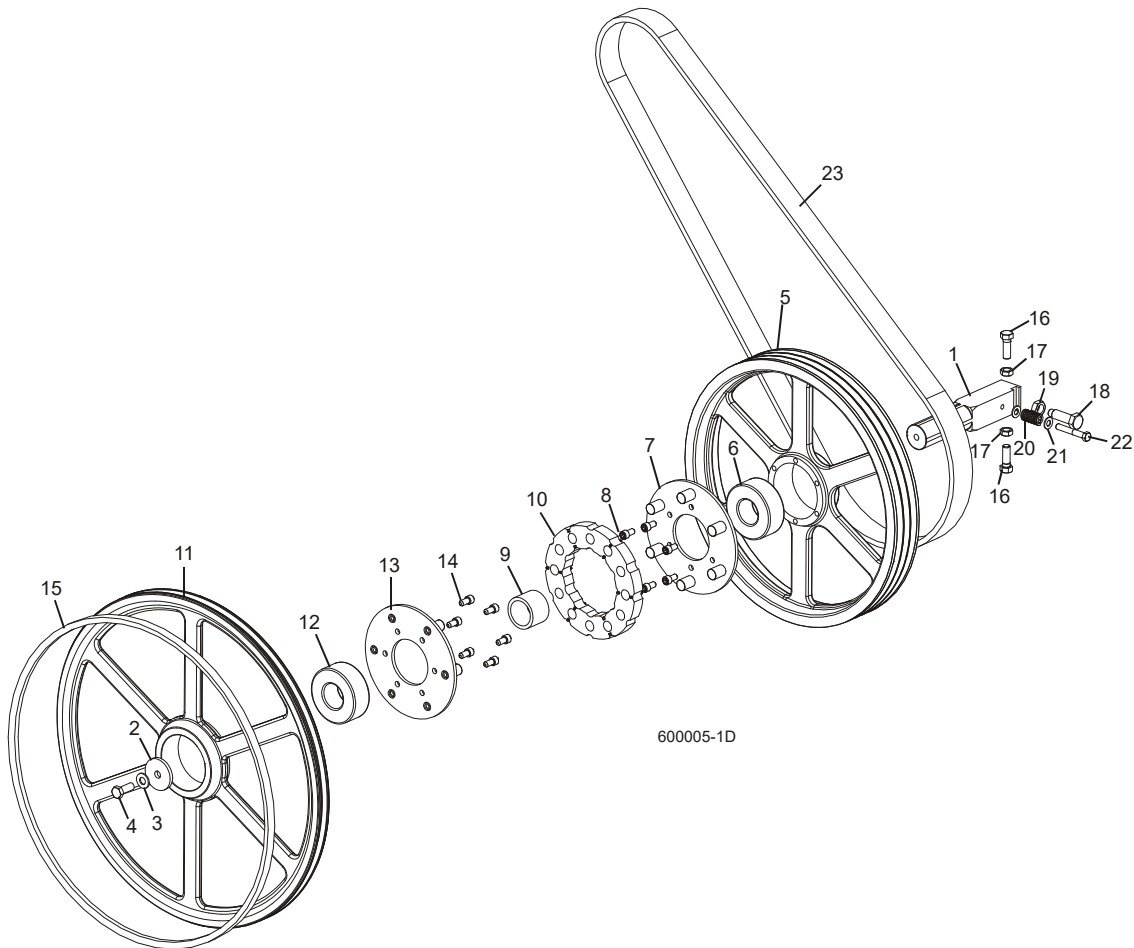

REF	DESCRIPTION (◆ Indicates Parts Available In Assemblies Only)	PART #	QTY.
	WHEEL ASSEMBLY, BLADE DRIVE	034359	1
1	Shaft, Blade Drive Wheel	033920	1
2	Washer, Blade Drive Wheel	033909	1
3	Washer, 1/2" SAE Flat	F05011-2	1
4	Bolt, 1/2-13 x 1 1/4" Hex Head Grade 5	F05008-37	1
	Pulley Assembly, 19" Blade Drive	034426	1
5	Pulley, Blade Drive	033809	1
6	Bearing, 5309-2RS	016014	1
7	Plate Assembly, Coupling	034424	1
8	Bolt, 3/8-24 x 3/4" Socket Head	F05007-154	6
9	Spacer, Drive Bearing	033921	1

3 Blade Wheel & Tensioner

Blade Drive Assembly

10	Ring, Drive Coupling	034418	1	
	Wheel Assembly, 24" Blade	017834	1	
11	Wheel, 24" Blade	034872	1	
12	Bearing, 5309-2RS	016014	1	
13	Plate Assembly, Coupling	034424	1	
14	Bolt, 3/8-24 x 3/4" Socket Head	F05007-154	6	
15	BELT, B72.5 BLADE WHEEL (NOT SHOWN)	017922-1 ¹	1	
16	BOLT, 1/2-20 X 1 1/2" HEX HEAD GRADE 5	F05008-53	2	
17	NUT, 1/2-20 HEX JAM	F05010-16	2	
18	BOLT, DRIVE WHEEL RETAINING	034360	1	
19	NUT, 5/8-18 HEX JAM	F05010-11	1	
20	SPRING, 3/4" OD X 1 1/2" LONG DIE	034430	1	
21	WASHER, 3/8" SAE FLAT	F05011-3	2	
22	BOLT, 3/8-16 X 2 1/2" HEX HEAD GRADE 5	F05007-125	1	
23	BELT, 3/5VFX950 DRIVE	045190	1	

¹ 017922-1 B72.5 Belt replaces 017922 supplied prior to 7/10. New belt provides longer service life.

3.2 Idle Blade Wheel Assembly

LT60HD/70HD

Rev. A5.03 - B3.01

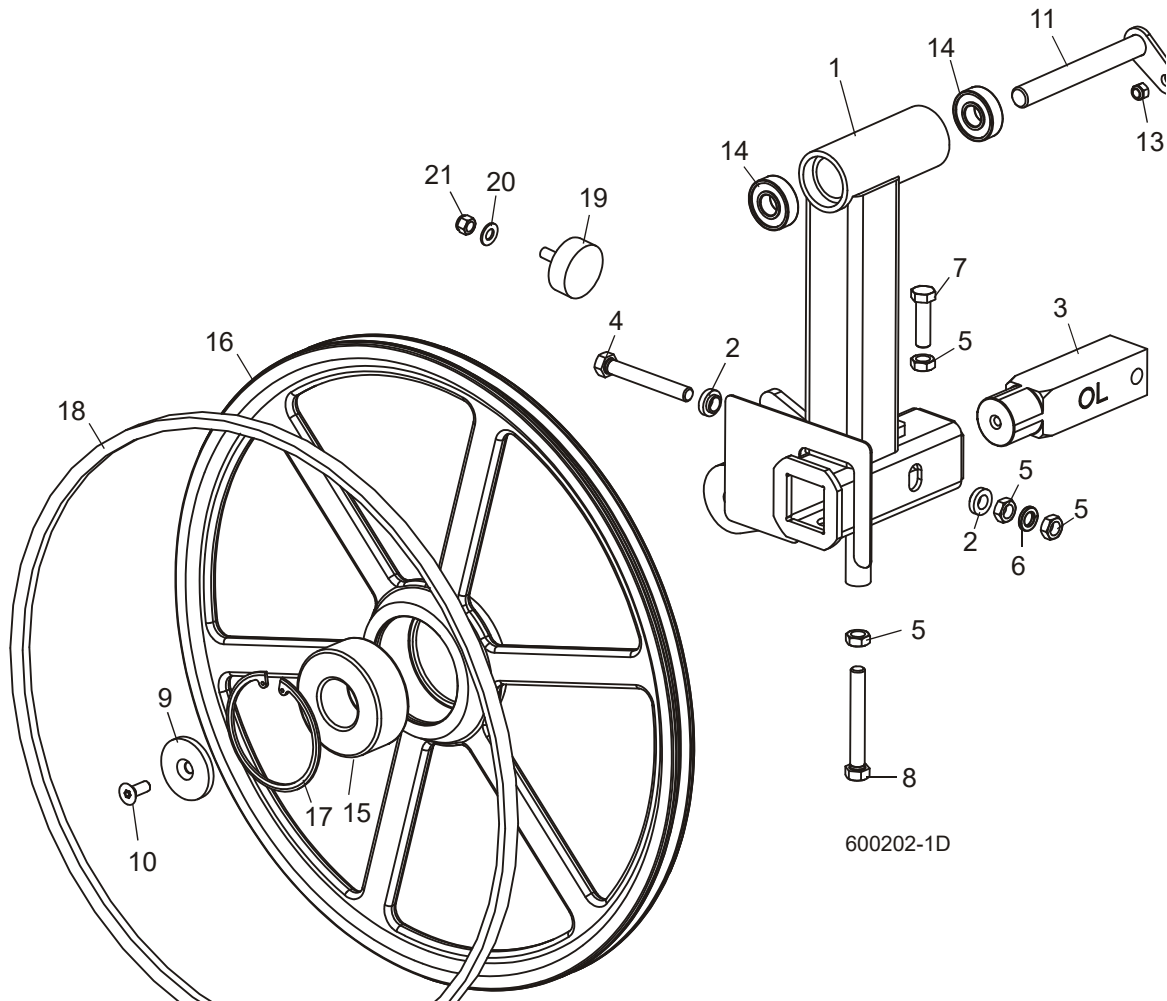

REF	DESCRIPTION (◆ Indicates Parts Available In Assemblies Only)	PART #	QTY.
	SHAFT ASSEMBLY, IDLE BLADE WHEEL (CAM TENSIONER)	036729	1
1	Tube Weldment, Idle Side Blade Wheel	048266 ¹	1
2	Spacer, .510" x .937" x .34"	S04253	2
3	Shaft, Idle Side Blade Wheel	017706	1
4	Bolt, 1/2-20 x 3 3/4" Hex Head Full Thread Grade 5	F05008-111	1
5	Nut, 1/2-20 Hex Jam	F05010-16	4
6	Washer, 1/2" Split Lock	F05011-9	1
7	Bolt, 1/2-20 x 1 3/4" Hex Head Full Thread	F05008-127	1
8	Bolt, 1/2-20 x 3 3/4" Hex Head Full Thread Grade 5	F05008-111 ¹	1
9	Washer, 3/32" ID x 2 1/4" OD x 1/4" Thick	016397	1
10	Bolt, 3/8-16 x 1" Flat Socket Head	F05007-64	1
11	Pin Weldment, Idle Wheel Pivot	034358	1
12	Bolt, 5/16-18 x 3/4" Hex Head	F05006-102	1

3

Blade Wheels & Tensioner

Idle Blade Wheel Assembly

13	Nut, 5/16-18 Hex Nylon Lock	F05010-58	1	
14	Bearing, #465966	034470	2	
	WHEEL ASSEMBLY, 24" IDLE BLADE	017835	1	
15	Bearing, 5309-2RS	016014	1	
16	Wheel, 24" Blade	034871	1	
17	Ring, 100 mm Beveled Inside Retaining	F04254-28	1	
18	BELT, B72.5 BLADE WHEEL (NOT SHOWN)	017922-1 ²	1	
19	BUMPER, TABLE	034175	1	
20	WASHER, 3/8" FLAT SAE	F05011-3	1	
21	NUT, 3/8-16 HEX NYLON LOCK	F05010-10	1	

¹ Idler Tube Weldment 048266 modified with threaded extension to provide easier access to bottom adjustment bolt (Rev. A7.00).

3 3/4" Bolt F05008-111 replaces 1 1/2" Bolt F05008-53 originally supplied.

² 017922-1 B72.5 Belt replaces 017922 supplied prior to 7/10. New belt provides longer service life.

3.3 Idle Blade Wheel Assembly

LT60HD/70HD

Rev. A1.03 - A5.02

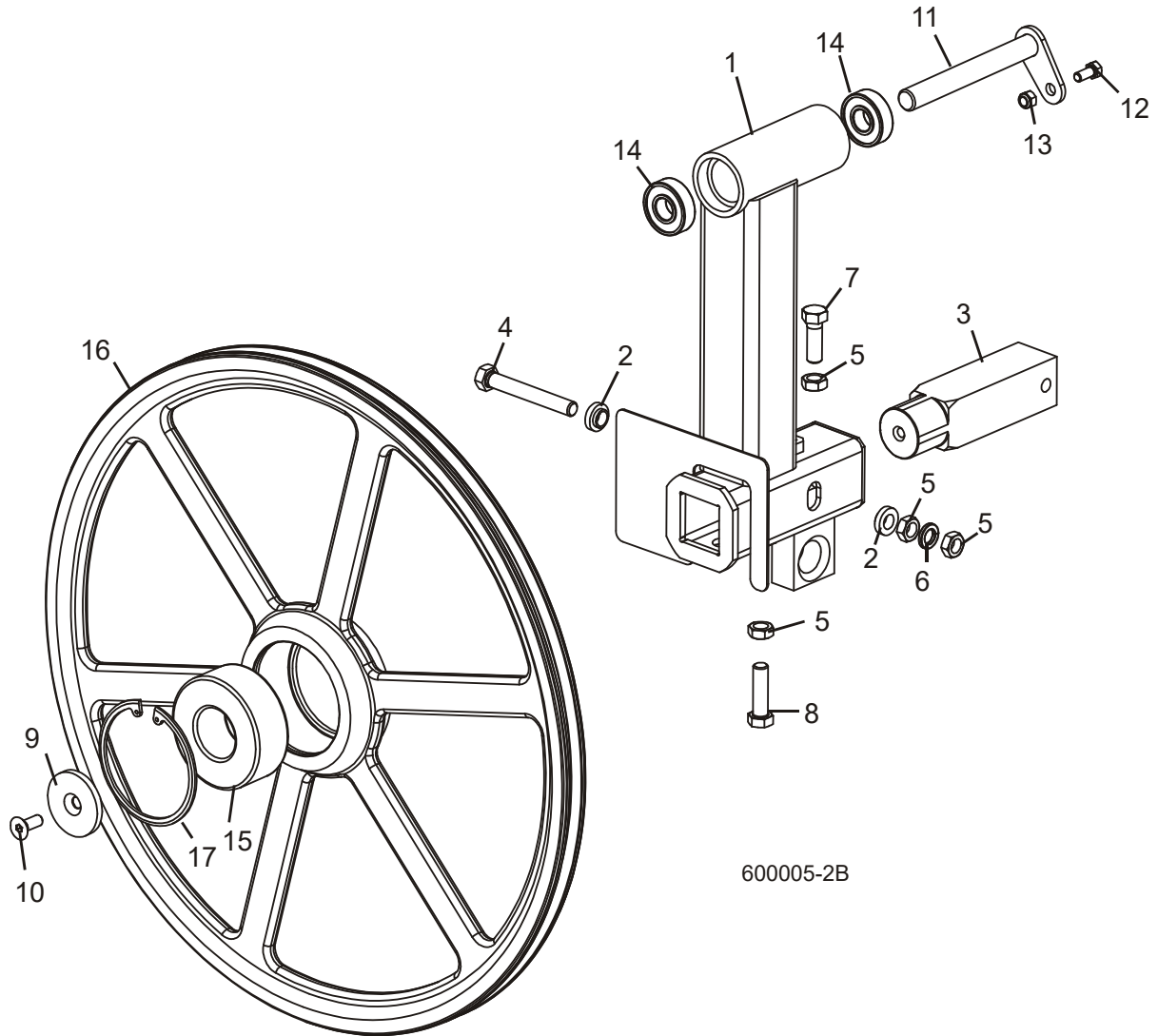

REF	DESCRIPTION (◆ Indicates Parts Available In Assemblies Only)	PART #	QTY.
	SHAFT ASSEMBLY, IDLE BLADE WHEEL	034356 ¹	1
1	Tube Weldment, Idle Side Blade Wheel	034296	1
2	Spacer, .510" x .937" x .34"	S04253	2
3	Shaft, Idle Side Blade Wheel	017706	1
4	Bolt, 1/2-20 x 3 3/4" Hex Head Full Thread Grade 5	F05008-111	1
5	Nut, 1/2-20 Hex Jam	F05010-16	4
6	Washer, 1/2" Split Lock	F05011-9	1
7	Bolt, 1/2-20 x 1 1/2" Hex Head Grade 5	F05008-53	1
8	Bolt, 1/2-20 x 1 3/4" Hex Head Full Thread	F05008-127	1

3

Blade Wheels & Tensioner

Idle Blade Wheel Assembly

9	Washer, 3/32" ID x 2 1/4" OD x 1/4" Thick	016397	1	
10	Bolt, 3/8-16 x 1" Flat Socket Head	F05007-64	1	
11	Pin Weldment, Idle Wheel Pivot	034358	1	
12	Bolt, 5/16-18 x 3/4" Hex Head	F05006-102	1	
13	Nut, 5/16-18 Hex Nylon Lock	F05010-58	1	
14	Bearing, #465966	034470	2	
	WHEEL ASSEMBLY, 24" IDLE BLADE	017835	1	
15	Bearing, 5309-2RS	016014	1	
16	Wheel, 24" Blade	034871	1	
17	Ring, 100 mm Beveled Inside Retaining	F04254-28	1	
	BELT, B72.5 BLADE WHEEL (NOT SHOWN)	017922-1 ²	1	

¹ Idle Blade Wheel Shaft Assembly 034356 replaced with 036729 Rev. A5.03 to accommodate new cam-style blade tensioner ([See Section 3.2](#)).

² 017922-1 B72.5 Belt replaces 017922 supplied prior to 7/10. New belt provides longer service life.

3.4 Hydraulic Blade Tensioner Assembly

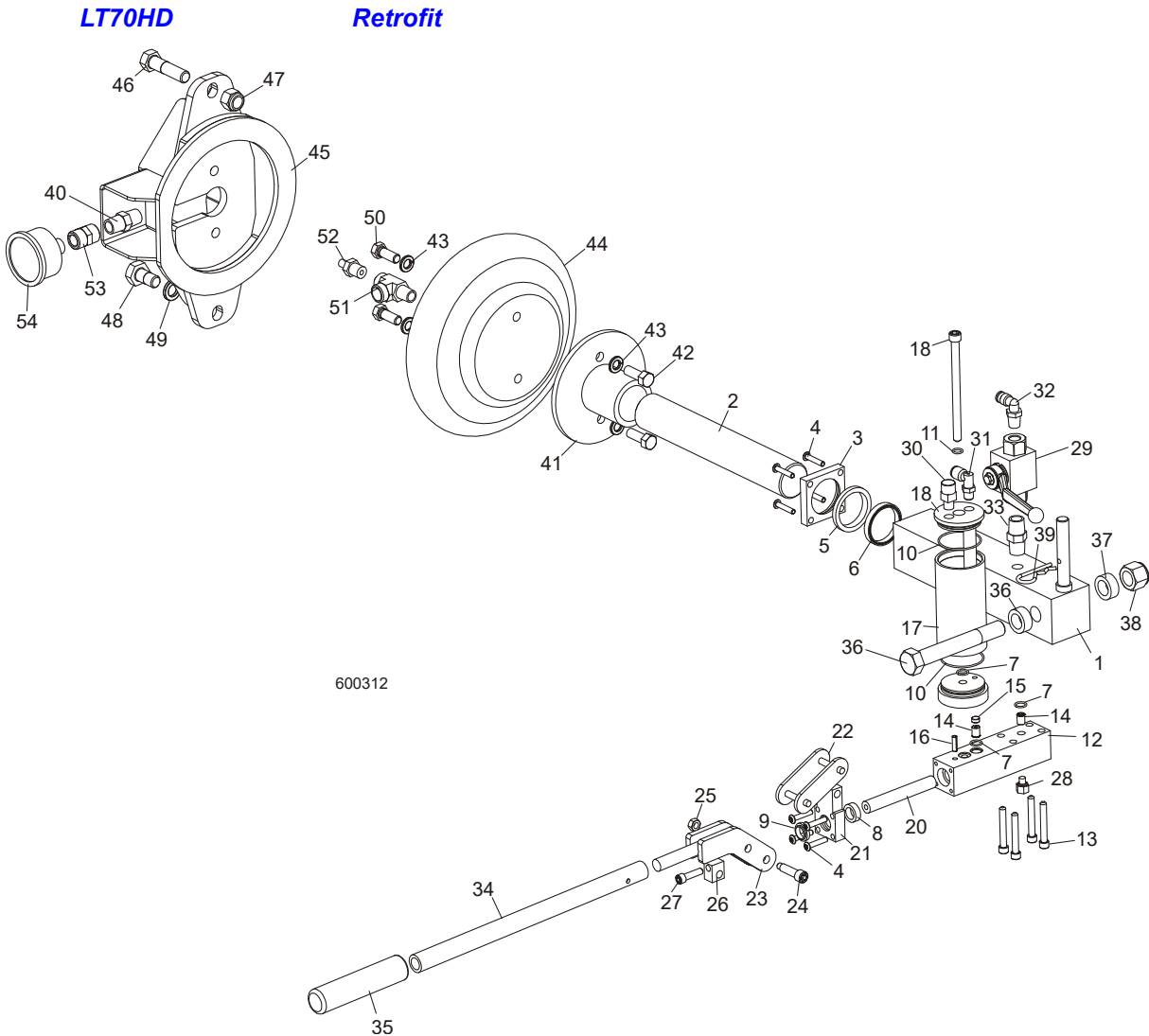

REF	DESCRIPTION (◆ Indicates Parts Available In Assemblies Only)	PART #	QTY.	
1-54	TENSIONER ASSEMBLY, LT70 HYDRAULIC BLADE	054844 ¹	1	◆
1-33	Block Kit, Hydraulic Tensioner Service	006529 ¹	1	
1-28	Block Assembly, Hydraulic Blade Tensioner	055315	1	◆
1	Block Weldment, Tensioner Cylinder	056809	1	
2	Rod, Tensioner Push	054848	1	
3	Block, Tensioner Push Rod Wiper	054846	1	
4	Screw, #10-24 x 1" Socket Button Head	F05004-43	8	
5-11	Seal Kit, Hydraulic Tensioner Service	006528	1	
5	Wiper, 1 1/2" Rod	056884	1	◆

3

Blade Wheels & Tensioner

Hydraulic Blade Tensioner Assembly

6	Seal, 1 1/2" Loaded Lip	056887	1	◆
7	O-Ring, 1/16" x 3/8" ID x 1/2" OD	056888	3	◆
8	Seal, 1/2" Loaded Lip	056886	1	◆
9	Wiper, 1/2" Rod	056885	1	◆
10	O-Ring, 1/16" x 1 5/8" ID x 1 3/4" OD	056889	2	◆
11	O-Ring, 5/16" ID x 7/16" OD #011	033477	1	◆
	Inst. Sheet, LT70 Hydraulic Blade Tensioner Seal Replacement	006825-1601	1	
12	Block, Tensioner Piston	054845	1	
13	Screw, 1/4-20 x 1 3/4" Socket Head	F05005-156	4	
14	Valve, 8mm Check	056883	2	
15	Screen, Hydraulic Cartridge	006274	1	
16	Pin, 3/16" x 5/8" Roll	F05012-22	1	
17	Tube, Hydraulic Fluid Tank	054837	1	
18	Cap Weldment, Hydraulic Reservoir	006366	1	
19	Screw, 5/16-18 x 4 1/2" Socket Head	F05006-135	1	
20	Rod, Tensioner Piston	054842	1	
21	Block, Tensioner Pivot Link	054843	1	
22	Link, C2080H Master	016796	1	
23	Link Weldment, Tensioner Pivot	055316	1	
24	Screw, 5/16" x 1" (1/4-20 Thread) Socket Head Shoulder	F05006-41	1	
25	Nut, 1/4-20 Hex Lock	F05010-21	1	
26	Block, Piston Link	054840	1	
27	Screw, 1/4-20 x 1" Socket Head	F05005-89	1	
28	Plug, 5/16-24 x 5/8" O-Ring	P10065	1	
29	Valve, 7250 PSI Hydraulic	056806	1	
30	Fitting, 1/8" NPT Protected Vent	056890	1	
31	Fitting, 1/4" NPT x 1/4" Tube 90° Elbow	P21519	1	
32	Fitting, 1/8" MPT x 1/4" Tube Swivel Elbow	P09736	1	
33	Fitting, 1/4" NPT Hex Nipple	P21524	1	
34	Tube, Tensioner Handle	055318	1	
35	Grip, 3/4" ID x 4 1/2" Handle	049031	1	
36	Bolt, 5/8-11 x 4 1/2" Hex Head Grade 5	F05009-10	1	
37	Spacer, 5/8" ID x 1" OD x 13/32"	056900	2	
38	Nut, 5/8-11 Hex Nylon Lock	F05010-34	1	
39	Pin, 1/8" x 1 13/16" Safety	P05059	1	
40	Fitting, 1/4" NPT Hex Nipple	P21524	1	
41	Tube Weldment, Tensioner	055317	1	
42	Bolt, 3/8-16 x 1" Hex Head	F05007-7	2	
43	Washer, 3/8" Split Lock	F05011-4	4	
44	Bag, Blade Tensioner Air	033984	1	
45	Plate Weldment, Air Bag Mount	034276	1	
46	Bolt, 1/2-13 x 2" Hex Head	F05008-76	1	
47	Nut, 1/2-13 Hex Nylon Lock	F05010-8	1	

Blade Wheels & Tensioner

Hydraulic Blade Tensioner Assembly

3

48	Bolt, 1/2-13 x 1" Hex Head	F05008-50	1	
49	Washer, 1/2" Split Lock	F05011-9	1	
50	Bolt, 3/8-16 x 1" Hex Head Grade 5	F05007-87	2	
51	Fitting, 1/4" NPT x 1/4" JIC Male Run Tee	P09141	1	
52	Fitting, 1/4" NPT Air Valve	034285	1	
53	Fitting, 1/4" NPT Coupling	P03420	1	
54	Gauge, Liquid-Filled Air	034278	1	

¹ Tensioner Assembly 054844 modified Rev. B4.08. 006529 Hydraulic Tensioner Service Block Kit no longer available. Use 065538 Blade Tensioner Retrofit Kit including hydraulic pump, pump mount, hydraulic cylinder and additional hardware to retrofit blade tensioner.

3.5 Hydraulic Blade Tensioner Assembly

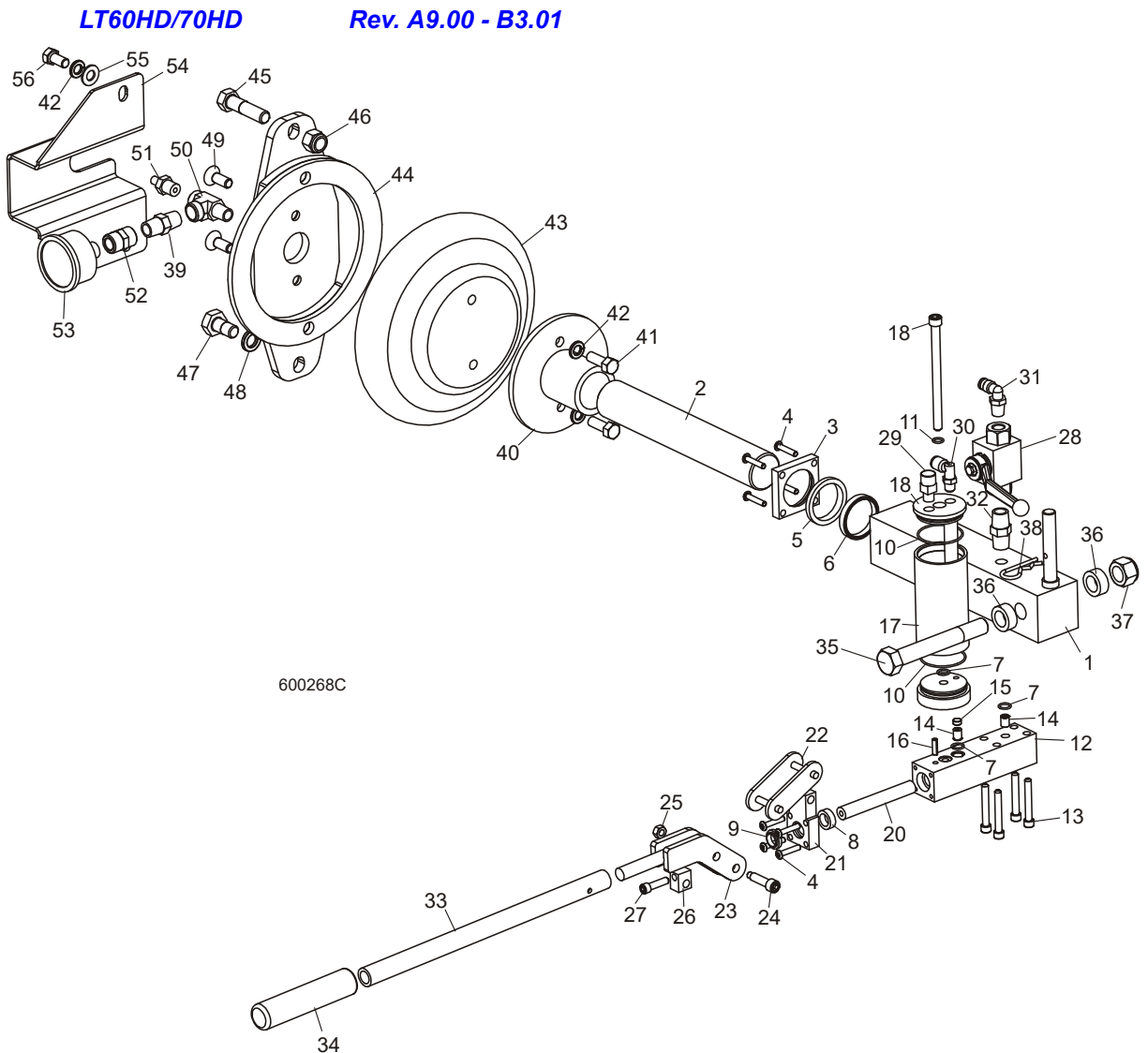

REF	DESCRIPTION (◆ Indicates Parts Available In Assemblies Only)	PART #	QTY.	
1-56	TENSIONER ASSEMBLY, LT60/LT70 HYDRAULIC BLADE	054844 ¹	1	◆
1-32	Block Kit, Hydraulic Tensioner Service	006529	1	
1-27	Block Assembly, Hydraulic Blade Tensioner	055315	1	◆
1	Block Weldment, Tensioner Cylinder	056809	1	
2	Rod, Tensioner Push	054848	1	
3	Block, Tensioner Push Rod Wiper	054846	1	
4	Screw, #10-24 x 1" Socket Button Head	F05004-43	8	
5-11	Seal Kit, Hydraulic Tensioner Service	006528	1	
5	Wiper, 1 1/2" Rod	056884	1	◆

Blade Wheels & Tensioner Hydraulic Blade Tensioner Assembly

3

6	Seal, 1 1/2" Loaded Lip	056887	1	◆
7	O-Ring, 1/16" x 3/8" ID x 1/2" OD	056888	3	◆
8	Seal, 1/2" Loaded Lip	056886	1	◆
9	Wiper, 1/2" Rod	056885	1	◆
10	O-Ring, 1/16" x 1 5/8" ID x 1 3/4" OD	056889	2	◆
11	O-Ring, 5/16" ID x 7/16" OD #011	033477 ²	1	◆
	Inst. Sheet, LT70 Hydraulic Blade Tensioner Seal Replacement	006825-1601	1	
12	Block, Tensioner Piston	054845 ²	1	
13	Screw, 1/4-20 x 1 3/4" Socket Head	F05005-156	4	
14	Valve, 8mm Check	056883	2	
15	Screen, Hydraulic Cartridge	006274	1	
16	Pin, 3/16" x 5/8" Roll	F05012-22	1	
17	Tube, Hydraulic Fluid Tank	054837	1	
18	Cap Weldment, Hydraulic Reservoir	006366	1	
19	Screw, 5/16-18 x 4 1/2" Socket Head	F05006-135	1	
20	Rod, Tensioner Piston	054842	1	
21	Block, Tensioner Pivot Link	054843	1	
22	Link, C2080H Master	016796	1	
23	Link Weldment, Tensioner Pivot	055316	1	
24	Screw, 5/16" x 1" (1/4-20 Thread) Socket Head Shoulder	F05006-41	1	
25	Nut, 1/4-20 Hex Lock	F05010-21	1	
26	Block, Piston Link	054840	1	
27	Screw, 1/4-20 x 1" Socket Head	F05005-89	1	
28	Valve, 7250 PSI Hydraulic	056806	1	
29	Fitting, 1/8" NPT Protected Vent	056890	1	
30	Fitting, 1/4" NPT x 1/4" Tube 90° Elbow	P21519	1	
31	Fitting, 1/8" MPT x 1/4" Tube Swivel Elbow	P09736	1	
32	Fitting, 1/4" NPT Hex Nipple	P21524	1	
33	Tube, Tensioner Handle	055318	1	
34	Grip, 3/4" ID x 4 1/2" Handle	049031	1	
35	Bolt, 5/8-11 x 4 1/2" Hex Head Grade 5	F05009-10	1	
36	Spacer, 5/8" ID x 1" OD x 13/32"	056900	2	
37	Nut, 5/8-11 Hex Nylon Lock	F05010-34	1	
38	Pin, 1/8" x 1 13/16" Safety	P05059	1	
39	Fitting, 1/4" NPT Hex Nipple	P21524	1	
40	Tube Weldment, Tensioner	055317	1	
41	Bolt, 3/8-16 x 1" Hex Head	F05007-7	2	
42	Washer, 3/8" Split Lock	F05011-4	4	
43	Bag, Blade Tensioner Air	033984	1	
44	Plate Weldment, Air Bag Mount	034276	1	
45	Bolt, 1/2-13 x 2" Hex Head	F05008-76	1	
46	Nut, 1/2-13 Hex Nylon Lock	F05010-8	1	
47	Bolt, 1/2-13 x 1" Hex Head	F05008-50	1	

3**Blade Wheels & Tensioner***Hydraulic Blade Tensioner Assembly*

48	Washer, 1/2" Split Lock	F05011-9	1	
49	Screw, 3/8-16 x 1" Flat Socket Head	F05007-64	2	
50	Fitting, 1/4" NPT x 1/4" JIC Male Run Tee	P09141	1	
51	Fitting, 1/4" NPT Air Valve	034285	1	
52	Fitting, 1/4" NPT Coupling	P03420	1	
53	Gauge, Liquid-Filled Air	034278	1	
54	Guard, Air Gauge	034245 ¹	1	
55	Washer, 3/8" SAE Flat	F05011-3	2	
56	Bolt, 3/8-16 x 3/4" Hex Head	F05007-27	2	

¹ Hydraulic Blade Tensioner provides improved durability and blade tensioning. Use kit 065697 to upgrade cam-style tensioner supplied on Rev. A5.03 - A8.01. Use kit 065696 to upgrade screw-style tensioner supplied on Rev. A3.01 - A5.02. Tensioner Assembly 054844 modified Rev. 4/10 ([See Section 3.4](#)). Tensioner Block Assembly 055315 includes modified Tensioner Block 054845 with access hole. Hole allows access to remove/service check valve. Plug for hole added to assembly. Air Bag Mount 034276 modified to include gauge guard and provide enough clearance for fittings Rev. 4/10 ([See Section 3.4](#)).

² O-Ring added 12/08 to seal water out. Requires modified Tensioner Block 054845. Tensioner Block Assembly 055315 includes modified Tensioner Block 054845 with access hole. Hole allows access to remove/service check valve. Plug for hole added to assembly ([See Section 3.4](#)).

3.6 Blade Tensioner Assembly

LT60HD/70HD

Rev. A5.03 - A8.01

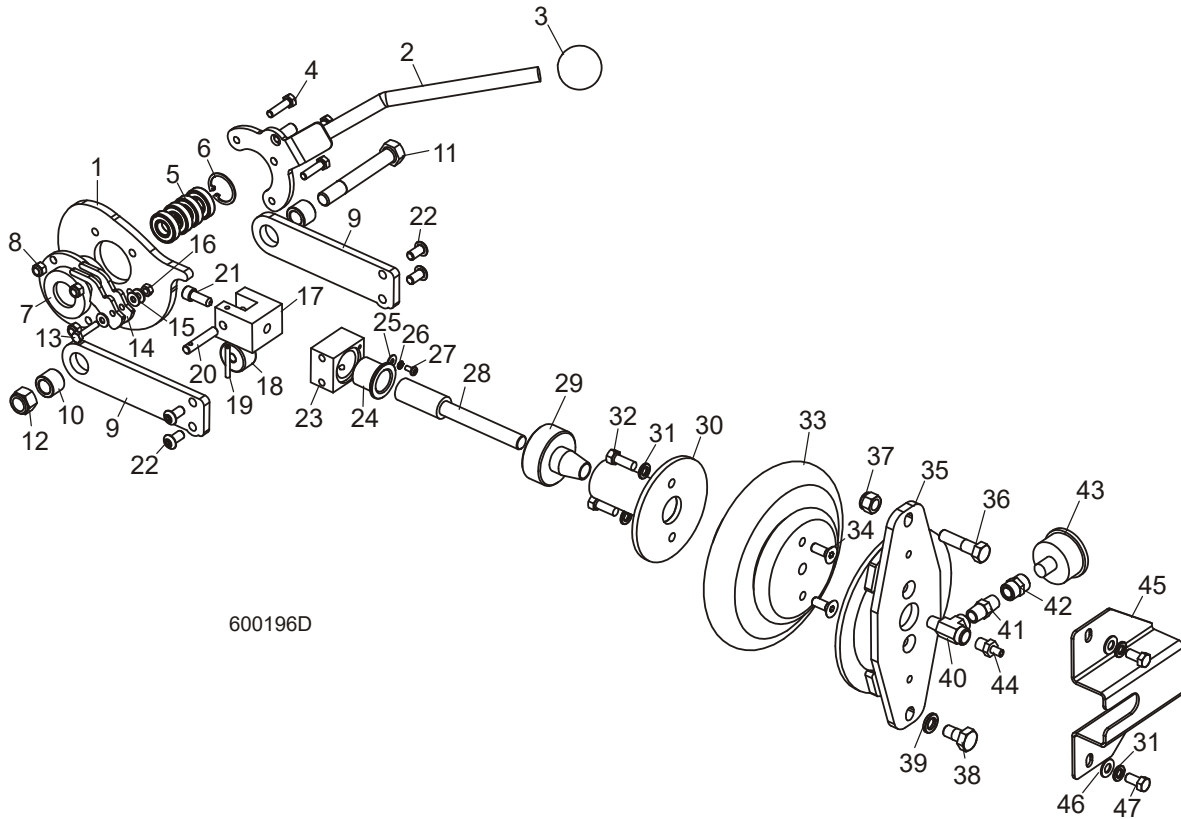

REF	DESCRIPTION (◆ Indicates Parts Available In Assemblies Only)	PART #	QTY.
	TENSIONER ASSEMBLY, LT60/LT70 BLADE	048268 ¹	1
	Handle Assembly, Blade Tensioner	048416	1
1	Cam, Blade Tensioner	047988	1
2	Handle Weldment, Blade Tensioner	048430 ²	1
3	Knob, 5/8-18 Ball	P04211	1
4	Bolt, 5/16-18 x 1 1/4" Hex Head Full Thread Grade 5	F05006-93 ³	3
5	Bearing, R-10	P04156	4
6	Ring, 1 3/8" Inside Retaining	F04254-11	1
7	Cam Weldment, Blade Tensioner	048212	1
8	Nut, 5/16-18 Hex Nylon Lock	F05010-58 ³	3
9	Plate, Blade Tensioner Link	048254	2
10	Spacer, 41/64" x 1" x 3/4"	015503	2
11	Bolt, 5/8-11 x 4 1/2" Hex Head Grade 5	F05009-10	1
12	Nut, 5/8-11 Hex Nylon Lock	F05010-34	1
13	Bolt, 1/4-20 x 1 1/4" Hex Head Grade 5	F05005-116	1

3

Blade Wheels & Tensioner

Blade Tensioner Assembly

14	Plate, Blade Tensioner Cam Lock	048435 ²	2	
15	Washer, 1/4" SAE Flat	F05011-11	3	
16	Nut, 1/4-20 Hex Lock	F05010-21	1	
17	Block, Bearing Mount	047987	1	
18	Bearing, 3/8" x 1 3/8" x 13/16 Cam	048219	1	
19	Pin, 3/16" x 1 1/2" Roll	F05012-17	1	
20	Pin, Bearing Mount	048210	1	
21	Screw, 3/8-16 x 1" Socket Head	F05007-52	1	
22	Screw, 3/8-16 x 3/4" Socket Button Head	F05007-21	4	
23	Block, Blade Tensioner Link Mount	047989	1	
24	Bushing, 1" ID x 1 1/4" OD Flanged	P109	1	
25	Washer, #10 SAE Flat	F05011-18	1	
26	Washer, #10 Split Lock	F05011-20	1	
27	Screw, #10-24 x 3/8" Phillips Pan Head	F05004-3	1	
28	Rod Weldment, Threaded Blade Tensioner	036739	1	
29	Nut, Blade Tensioner Adjustment	048433	1	
30	Tube Weldment, Blade Tensioner	048414	1	
31	Washer, 3/8" Split Lock	F05011-4	4	
32	Bolt, 3/8-16 x 1" Hex Head	F05007-7	2	
33	Bag, Blade Tensioner Air	033984	1	
34	Screw, 3/8-16 x 1" Flat Socket Head	F05007-64	2	
35	Plate Weldment, Air Bag Mount	034276	1	
36	Bolt, 1/2-13 x 2" Hex Head	F05008-76	1	
37	Nut, 1/2-13 Hex Nylon Lock	F05010-8	1	
38	Bolt, 1/2-13 x 1" Hex Head	F05008-50	1	
39	Washer, 1/2" Split Lock	F05011-9	1	
40	Fitting, 1/4" NPT x 1/4" JIC Male Run Tee	P09141 ⁴	1	
41	Fitting, 1/4" NPT Nipple Hex	P21524	1	
42	Fitting, 1/4" NPT Coupling	P03420	1	
43	Gauge, Liquid-Filled Air	034278	1	
44	Fitting, 1/4" NPT Air Valve	034285	1	
45	Guard, Air Gauge	034245	1	
46	Washer, 3/8" SAE Flat	F05011-3	2	
47	Bolt, 3/8-16 x 3/4" Hex Head	F05007-27	2	

¹ Blade Tensioner 048268 replaced with Hydraulic Blade Tensioner 054844 Rev. A9.00 ([See Section 3.4](#)). Use kit 065697 to retrofit cam-style tensioner supplied after Rev. A5.03.

² Handle weldment and locking plates modified Rev. A7.01. Angled handle eliminates possible pinch point with blade guide motor when handle is disengaged. Lock plates modified to improve operation of lock when blade tension handle is engaged. Warning decal 049633 ([See Section 4.10](#)) added to warn customer to use two hands when operating the tensioner and to ensure locking plates engage when blade is tensioned. All previous revisions (A5.03 - A7.00) to be retrofitted with new handle, lock plates and decal (Kit #052432).

³ Third Bolt F05006-93 and Nut F05010-58 added 4/06 to prevent deflection of handle plate. Bolt can be added to previous revisions.

⁴ P09141 Male Run Tee replaces 015486 Branch Tee to provide better fit (Rev. A7.02).

3.7 Blade Tensioner Assembly

LT60HD/70HD

Rev. A3.01 - A5.02

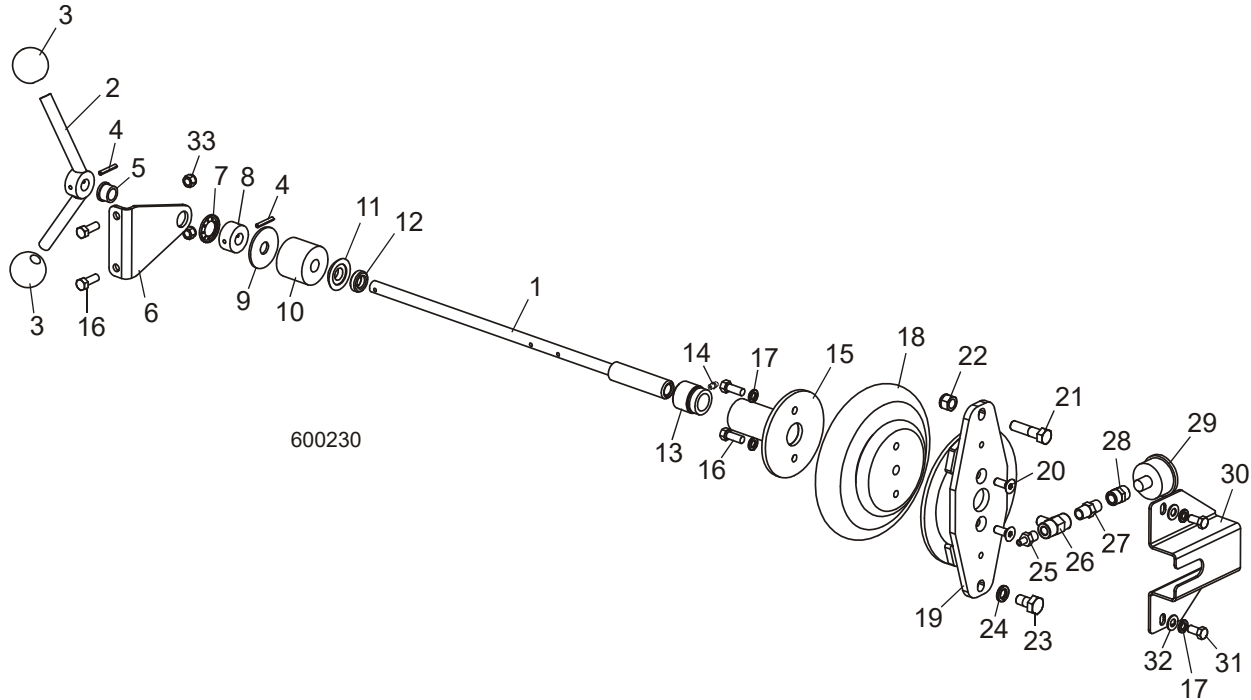

REF	DESCRIPTION (◆ Indicates Parts Available In Assemblies Only)	PART #	QTY.
	TENSIONER ASSEMBLY, LT70 BLADE	034272 ¹	1
1	Shaft Weldment, Blade Tensioner	014846	1
2	Handle Weldment, Blade Tensioner	034271	1
3	Knob, 5/8-11 Ball	P04211	2
4	Pin, 3/16" x 1 1/4" Roll	F05012-16	2
5	Bushing, 5/8" ID x 7/8" OD x 1/2" Long Bronze	P05135	1
6	Plate, Tensioner Handle Support	033810	1
7	Washer, 7/8" Push Nut 5115-87	F04254-31	1
8	Hub, Tensioner Handle	014921	1
9	Washer, .66 x 2.25 x 11Ga	017711	1
10	Bushing, 11/16" x 2 1/8" x 1 3/4" Rubber	P12165	1
11	Pivot, Tension Thrust Bearing	034502	1
12	Bearing, 5/8" Thrust	P04214	1
13	Nut, 1-10 LH Stepped Acme	017707	1
14	Fitting, 1/4-28 Grease	P05060	1
15	Tube Weldment, Tensioner Nut	034275	1
16	Bolt, 3/8-16 x 1" Hex Head	F05007-7	4
17	Washer, 3/8" Split Lock	F05011-4	4
18	Bag, W01-358-7564 Air	033984	1

3**Blade Wheels & Tensioner***Blade Tensioner Assembly*

19	Plate Weldment, Air Bag Mount	034276	1	
20	Bolt, 3/8-16 x 1" Flat Socket Head	F05007-64	2	
21	Bolt, 1/2-13 x 2" Hex Head	F05008-76	1	
22	Nut, 1/2-13 Hex Nylon Lock	F05010-8	1	
23	Bolt, 1/2-13 x 1" Hex Head	F05008-50	1	
24	Washer, 1/2" Split Lock	F05011-9	1	
25	Fitting, 1/4" NPT Air Tank Valve	034285	1	
26	Fitting, 1/4" NPT Tee	015486	1	
27	Nipple, 1/4" NPT Hex	P21524	1	
28	Coupling, 1/4" NPT Steel	P03420	1	
29	Gauge, Liquid Filled Air	034278	1	
30	Guard, Air Gauge	034245	1	
31	Bolt, 3/8-16 x 3/4" Hex Head	F05007-27	2	
32	Washer, 3/8" SAE Flat	F05011-3	2	
33	Nut, 3/8-16 Hex Nylon Lock	F05010-10	2	

¹ Blade Tensioner 034272 no longer available. Use kit 065696 to upgrade to Hydraulic Blade Tensioner ([See Section 3.4](#)).

SECTION 4 SAW HEAD

4.1 Middle Throat Screw

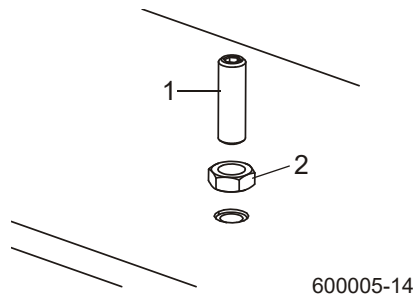

REF	DESCRIPTION (◆ Indicates Parts Available In Assemblies Only)	PART #	QTY.	
1	SCREW, 3/8-16 X 1 1/2" OVAL POINT SOCKET SET	F05007-190	1	
2	NUT, 3/8-16 HEX JAM	F05010-29	1	

4 Saw Head Belt Tensioner

4.2 Belt Tensioner

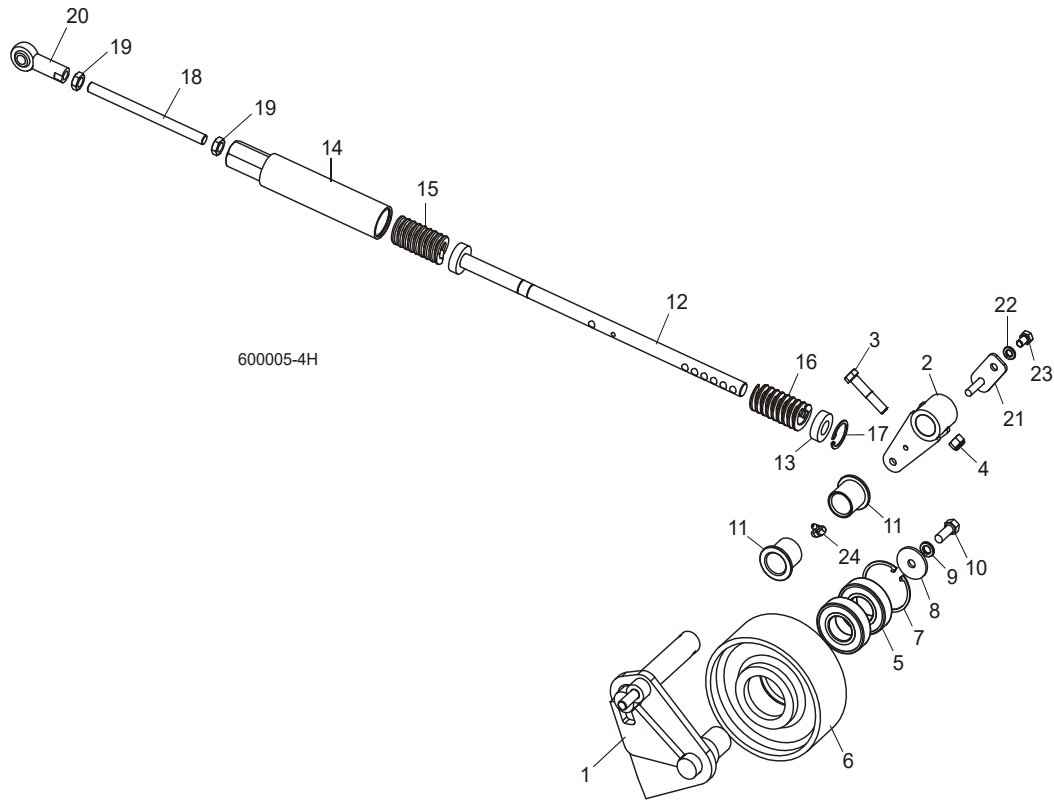

REF	DESCRIPTION (◆ Indicates Parts Available In Assemblies Only)	PART #	QTY.
	TENSIONER ASSEMBLY, DRIVE BELT	034894	1
	Pivot Kit, Drive Belt Tensioner Retrofit	038934 ¹	1
1	Arm Weldment, Drive Belt Tensioner	034893 ²	1
2	Pivot Weldment, Drive Belt Tensioner	034593	1
	Instruction Sheet, Tensioner Pivot Retrofit	038934-1265	1
3	Bolt, 3/8-16 x 2" Hex Head Grade 5	F05007-124	1
4	Nut, 3/8-16 Hex Nylon Lock	F05010-10	1
5	Bearing, 6206 25" Idler	P11035	2
6	Idler, Drive Belt	033941	1
7	Ring, 62mm Inside Retaining	F04254-12	1
8	Washer, 3/8" x 1 1/2" x 1/8"	F05011-104	1
9	Washer, 3/8" Split Lock	F05011-4	1
10	Bolt, 3/8-16 x 1" Hex Head	F05007-7	1
11	Bushing, 1" ID x 1 1/4" OD Flanged	P109	2
	Rod Kit, Drive Belt Tensioner	003193 ³	1
12	Rod Weldment, Drive Belt Tensioner	017923	1
13	Washer, Tensioner	034674	1

14	Tube Weldment, Drive Belt Tensioner	034689	1	
	Spring Kit, Belt Tensioner Retrofit	036501	1	
15	Spring, 1 1/4" OD x 2 1/2" Die, Heavy	036136	2	
16	Spring, 1 1/4" OD x 2 1/2" Die, Medium (Blue)	065242 ⁴	1	
	Instruction Sheet, Belt Tensioner Spring Retro	036501-1148	1	
17	Ring, 1 15/16" Inside Retaining	F04254-44	1	
18	Rod, 7/16-20 x 6" Threaded	017924	1	
19	Nut, 7/16-20 Hex Jam	F05010-38	2	
20	Rod End, 7/16-20 Right Hand Female	017925	1	
21	Pin Weldment, Drive Belt Tensioner	034673	1	
22	Washer, 5/16" Split Lock	F05011-13	1	
23	Bolt, 5/16-18 x 1/2" Hex Head Grade 5	F05006-15	1	
24	FITTING, 3/16" STRAIGHT GREASE	P04107 ⁵	1	

¹ Retrofit 038934 for Revs. prior to A7.07. Arm Weldment 034893 and Pivot Weldment 034593 modified to increase range of motion to reduce strain on gearbox.

² Gussets added to arm to improve durability (Rev. A3.03).

³ Pre-Assembled Kit 003193 available 11/06 to provide easier customer replacement.

⁴ Added Rev. B4.04 to replace 1 1/4" OD x 2 1/2" Die Heavy Spring (036136).

⁵ Grease fitting added 4/06 to provide ability to grease belt tensioner pivot.

4 Saw Head

Brake Assembly (DC Only)

4.3 Brake Assembly (DC Only)

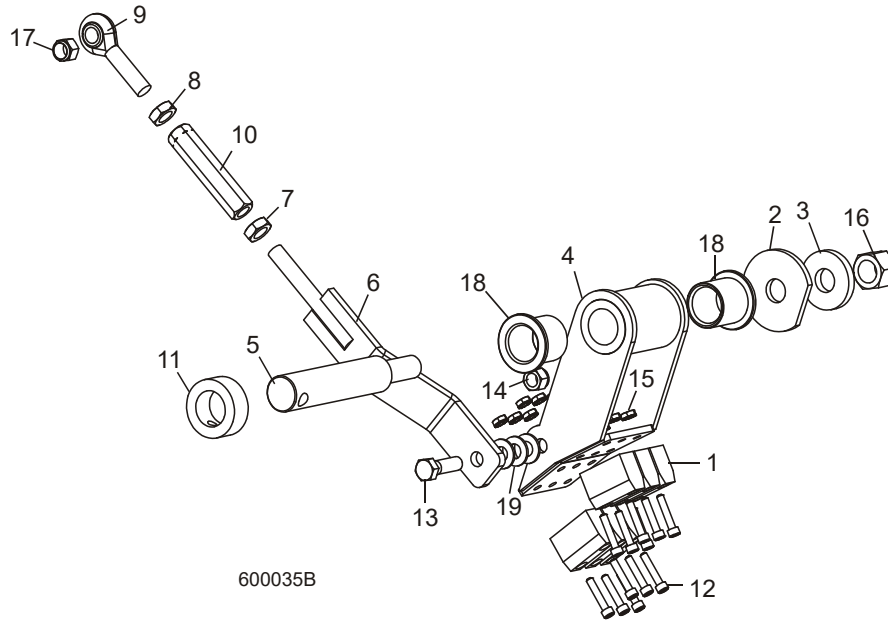

REF	DESCRIPTION (◆ Indicates Parts Available In Assemblies Only)	PART #	QTY.
	BRAKE ASSEMBLY, LT60/70	034886	1
1	Block, Blade Wheel Brake	016488	6
2	Washer, 21/32" x 2 1/4" x 3/16"	017838	1
3	Washer, 21/32" x 1 5/8" x 1/4"	034685	1
4	Arm Weldment, Pivot Brake	034883	1
5	Shaft, Pivot Brake	034885	1
	Linkage Assembly, Pivot Brake	034892	1
6	Arm Weldment, Pivot Brake Lik	034891	1
7	Nut, 7/16-20 Jam	F05010-38	1
8	Nut, 7/16-20 Left Hand Jam	F05010-87	1
9	Rod End, 7/16-20 Left Hand Male	P11578	1
10	Turnbuckle, 3" Adjustment	S11577	1
11	Collar, 1" Lock	038090	1
12	Bolt, #10-24 x 1" Socket Head	F05004-2	12
13	Bolt, 3/8-16 x 1 1/4" Hex Head Grade 5	F05007-123	1
14	Nut, 3/8-16 Hex Nylon Lock	F05010-10	1
15	Nut, #10-24 Self-Locking Hex	F05010-14	12
16	Nut, 5/8-18 Hex Nylon Lock	F05010-71	1
17	Nut, 7/16-20 Hex Nylon Lock	F05010-83	1
18	Bushing, 1" ID x 1 1/4" OD Flanged	P109	2
19	Washer, 3/8" SAE Flat	F05011-3	3

4.4 Autoclutch Assembly (DC Only)

LT60HD/70HD

Rev. A6.00 - B3.01

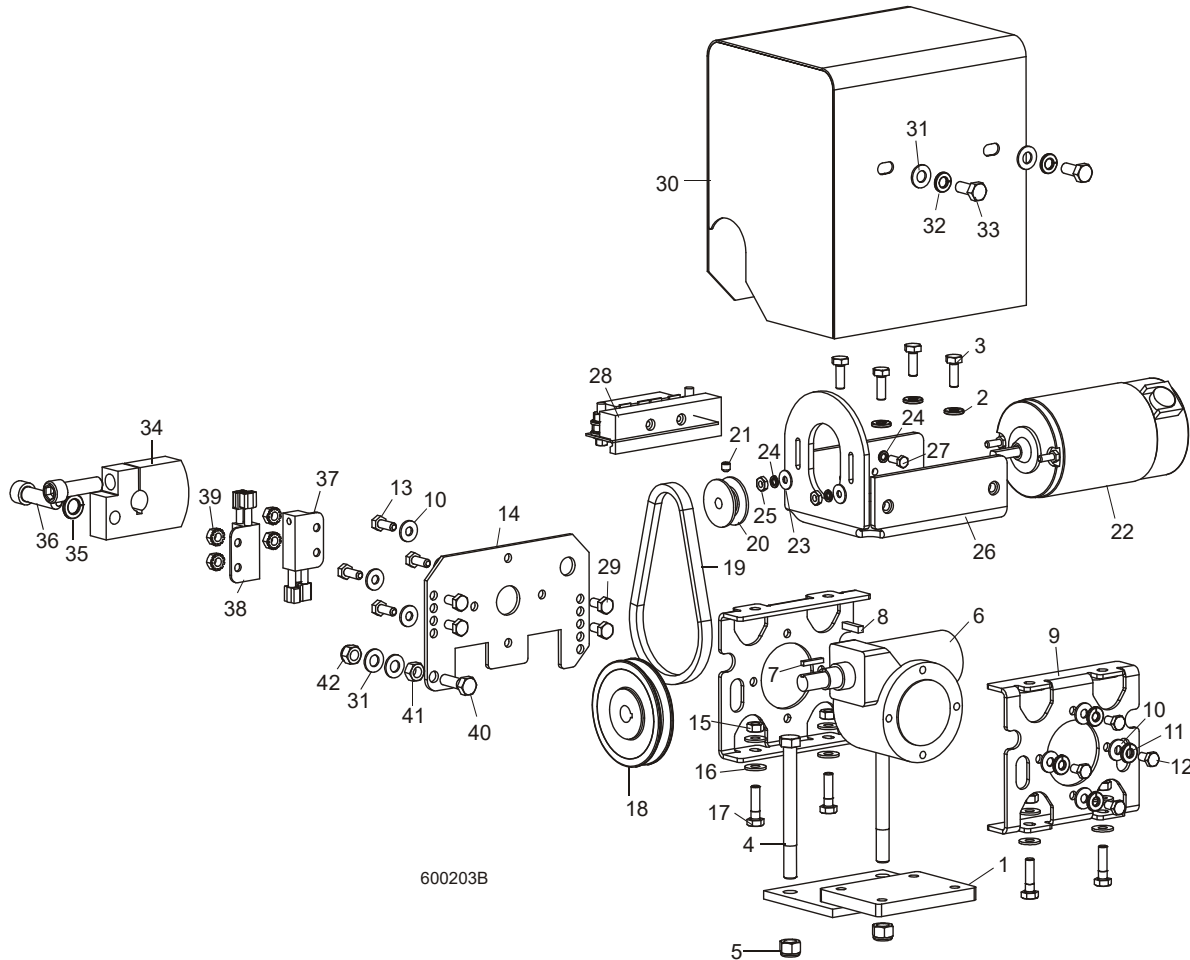

REF	DESCRIPTION (◆ Indicates Parts Available In Assemblies Only)	PART #	QTY.
	AUTOCLUTCH ASSEMBLY, LT60/70	034692	1
1	Plate Weldment, Autoclutch Mount	034678	1
2	Washer, 1/4" Split Lock	F05011-14	4
3	Bolt, 1/4-20 x 3/4" Hex Head Grade 5	F05005-123	4
4	Bolt, 3/8-16 x 4" Hex Head	F05007-4	2
5	Nut, 3/8-16 Hex Nylon Lock	F05010-10	2
	Gearbox Assy, LT60/70 Autoclutch	036787	1
6	Gearbox, 61:1 512 Reducer	036764	1
7	Key, 1/8" Sq. x 3/4" Long	036803	1
8	Key, 3/16" Sq. x 3/4" Long	S03060	1
9	Mount Weldment, Autoclutch Gearbox LT60/70	036794	2
10	Washer, 1/4" SAE Flat	F05011-11	8

4

Saw Head*Autoclutch Assembly (DC Only)*

11	Washer, 1/4" Split Lock	F05011-14	4	
12	Bolt, M6 x 12 Full Thread Grade 8.8 Hex Head	F05005-99	4	
13	Bolt, M6 x 1 x 16mm Hex Head	F05004-219	4	
14	Plate, Sensor Mount	036785	1	
15	Nut, 1/4-20 Hex Lock	F05010-21	4	
16	Washer, 1/4" SAE Flat	F05011-11	8	
17	Bolt, 1/4-20 x 1" Hex Head Grade 5	F05005-101	4	
18	Pulley, OK30 x 1/2" Special	015075	1	
19	Belt, 3L140	016219	1	
20	Pulley, 1.42" x .32" Motor	015074	1	
21	Screw, 1/4-28 x 1/4" Socket Head Cup Point Set	F05005-105	1	
22	Motor Assembly, Autoclutch Replacement	016021	1	
	Brush Kit, Leeson Motor External	034002	1	
23	Washer, #10 SAE Flat	F05011-18	2	
24	Washer, #10 Split Lock	F05011-20	4	
25	Nut, #10-32 Hex	F05010-27	2	
26	Bracket Weldment, Autoclutch Motor Mount	034670	1	
27	Bolt, #10-24 x 1/2" Hex Head	F05004-27	2	
	Module Kit, Autoclutch Upgrade	052791 ¹	1	
28	Module Assembly, Mosfet 4X Autoclutch	024618 ¹	1	◆
	Capacitor Assembly, 1000uF with 1/4" Ring Terminals	024163 ¹	1	
	Diode Assembly, Autoclutch Gate	061052	1	
	Tie Wrap, 3/16" x 6" Black UV	F05089-3	1	
	Instruction Sheet, Autoclutch Mosfet Installation	052791-1260	1	
29	Bolt, 1/4-20 x 1/2" Hex Head	F05005-15	4	
30	Guard Weldment, Autoclutch	034667	1	
31	Washer, 5/16" SAE Flat	F05011-17	4	
32	Washer, 5/16" Split Lock	F05011-13	2	
33	Bolt, 5/16-18 x 3/4" Hex Head	F05006-5	2	
34	Cam, Autoclutch	034675	1	
35	Washer, 7/16" Split Lock	F05011-48	1	
36	Bolt, 7/16-20 x 1 1/2" Socket Head	F05007-55	2	
37	Sensor Assembly, AutoClutch Engage	051337	1	
38	Sensor Assembly, Proximity Magnetic	024627	1	
39	Nut, 1/4-20 Hex Self-Locking	F05010-9	4	
40	Bolt, 5/16-18 x 1" Hex Head	F05006-1	1	
41	Nut, 5/16-18 Hex	F05010-17	1	
42	Nut, 5/16-18 Hex Nylon Lock	F05010-58	1	

¹ Use Mosfet Module Upgrade Kit 052791 to replace original Mosfet Module 024618. Upgrade includes Capacitor Assembly 024163 and Mosfet Assembly with added diode supplied with Rev. A7.05 and later. This upgrade protects against inductive voltage spikes.

4.5 Autoclutch Assembly (DC Only)

LT60HD/70HD

Rev. A3.01 - A5.03

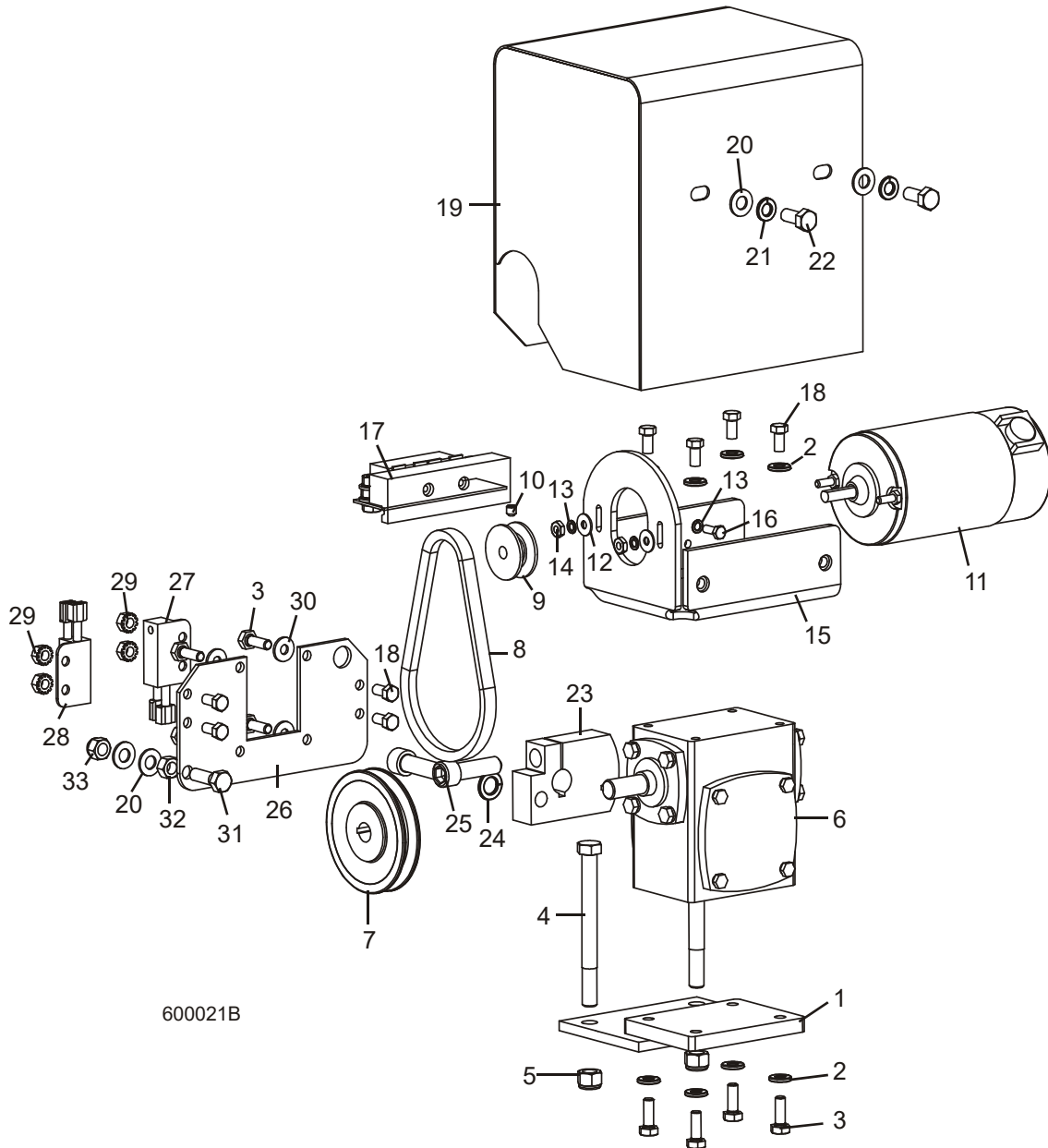

REF	DESCRIPTION (◆ Indicates Parts Available In Assemblies Only)	PART #	QTY.
	AUTOCLUTCH ASSEMBLY, LT60/70	034692 ¹	1
1	Plate Weldment, Autoclutch Mount	034678	1
2	Washer, 1/4" Split Lock	F05011-14	8
3	Bolt, 1/4-20 x 3/4" Hex Head Full Thread	F05005-1	8
4	Bolt, 3/8-16 x 4" Hex Head	F05007-4	2

4

Saw Head

Autoclutch Assembly (DC Only)

5	Nut, 3/8-16 Hex Nylon Lock	F05010-10	2	
6	Gearbox, 60:1 I034	015067 ²	1	◆
7	Pulley, OK30 x 1/2" Special	015075	1	
8	Belt, 3L140	016219	1	
9	Pulley, 1.42" x .32" Motor	015074	1	
10	Screw, 1/4-28 x 1/4" Socket Head Cup Point Set	F05005-105	1	
11	Motor Assembly, Autoclutch Replacement	016021	1	
	Brush Kit, Leeson Motor External	034002	1	
12	Washer, #10 SAE Flat	F05011-18	2	
13	Washer, #10 Split Lock	F05011-20	4	
14	Nut, #10-32 Hex	F05010-27	2	
15	Bracket Weldment, Autoclutch Motor Mount	034670	1	
16	Bolt, #10-24 x 1/2" Hex Head	F05004-27	2	
	Module Kit, Autoclutch Upgrade	052791 ³	1	
17	Module Assembly, Mosfet 4X Autoclutch	024618 ³	1	◆
	Capacitor Assembly, 1000uF with 1/4" Ring Terminals	024163 ³	1	
	Diode Assembly, Autoclutch Gate	061052	1	
	Tie Wrap, 3/16" x 6" Black UV	F05089-3	1	
	Instruction Sheet, Autoclutch Mosfet Installation	052791-1260	1	
18	Bolt, 1/4-20 x 1/2" Hex Head	F05005-15	8	
19	Guard Weldment, Autoclutch	034667	1	
20	Washer, 5/16" SAE Flat	F05011-17	4	
21	Washer, 5/16" Split Lock	F05011-13	2	
22	Bolt, 5/16-18 x 3/4" Hex Head	F05006-5	2	
23	Cam, Autoclutch	034675	1	
24	Washer, 7/16" Split Lock	F05011-48	1	
25	Bolt, 7/16-20 x 1 1/2" Socket Head	F05007-55	2	
26	Plate, Sensor Mounting	016324	1	
27	Sensor Assembly, AutoClutch Engage (D51/D62)	051337 ¹	1	
	Sensor Assembly, Proximity Magnetic (D42)	024627 ¹	1	
28	Sensor Assembly, Proximity Magnetic	024627	1	
29	Nut, 1/4-20 Hex Self-Locking	F05010-9	4	
30	Washer, 1/4" SAE Flat	F05011-11	4	
31	Bolt, 5/16-18 x 1" Hex Head	F05006-1	1	
32	Nut, 5/16-18 Hex	F05010-17	1	
33	Nut, 5/16-18 Hex Nylon Lock	F05010-58	1	

¹ Autoclutch Assembly 034692 modified for use with Caterpillar engine options. If assembly to be used on sawmill with D42 Kubota engine, leave white wire from Engage Sensor 051337 unused. If replacing Engage Sensor, use 024627 for D42 and use 051337 for D51/D62.

² Gearbox 015067 replaced Rev. A6.00 to improve durability. Use Gearbox Assembly 036787 to retrofit previous revisions ([See Section 4.4](#)).

³ Use Mosfet Module Upgrade Kit 052791 to replace original Mosfet Module 024618. Upgrade includes Capacitor Assembly 024163 and Mosfet Assembly with added diode supplied 5/06 and later. This upgrade protects against inductive voltage spikes.

4.6 Board Return Assembly

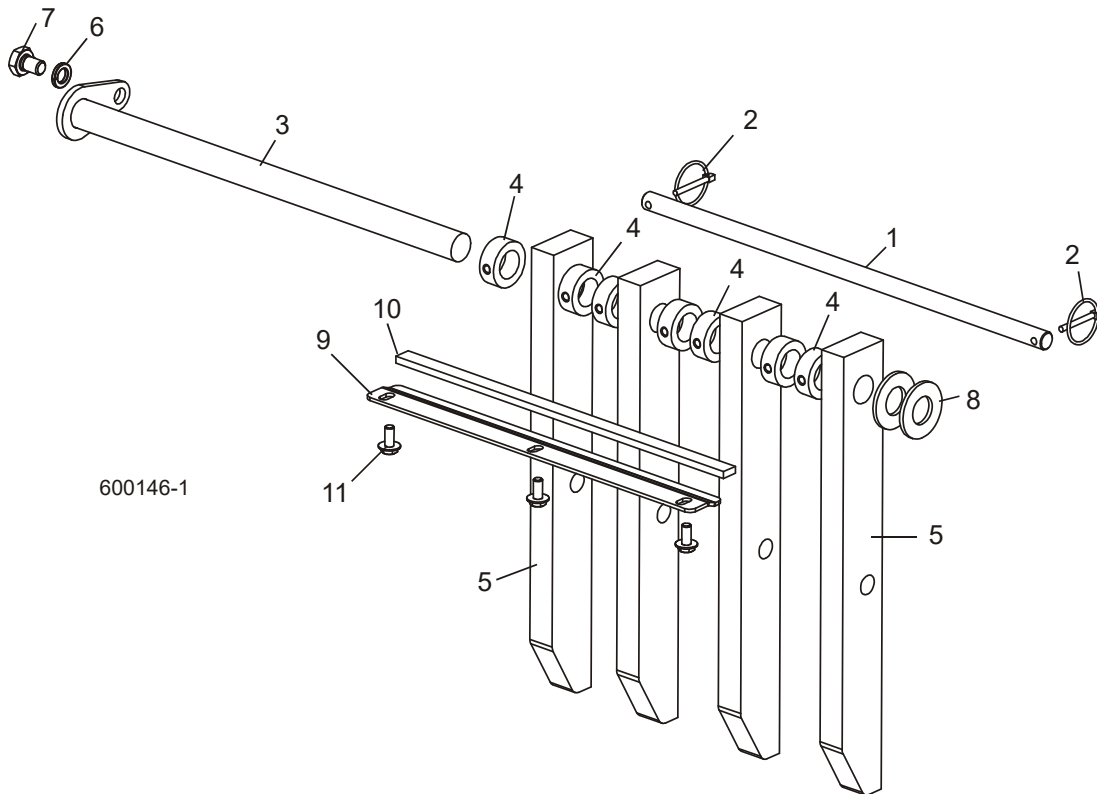

REF	DESCRIPTION (◆ Indicates Parts Available In Assemblies Only)	PART #	QTY.	
1	PIN, BOARD RETURN LOCK	034565	1	
2	PIN, 3/16" W/CHAIN	017604	2	
3	PIN WELDMENT, BOARD RETURN MOUNT	034567	1	
4	COLLAR, 1" LOCK	038090	7	
5	ARM, BOARD RETURN W/STOP	034561	4	
6	WASHER, 1/2" SPLIT LOCK	F05011-9	1	
7	BOLT, 1/2-13 X 3/4" HEX HEAD GRADE 5	F05008-101	1	
8	WASHER, 1" SAE	F05011-28	2	
9	BRACKET, BOARD RETURN BUMPER	017856	1	
10	BUMPER, BOARD RETURN	017857	1	
11	BOLT, 5/16-18 X 3/4" HEX WASHER HEAD	F05006-101	3	

4 Saw Head

Water Lube Assembly

4.7 Water Lube Assembly

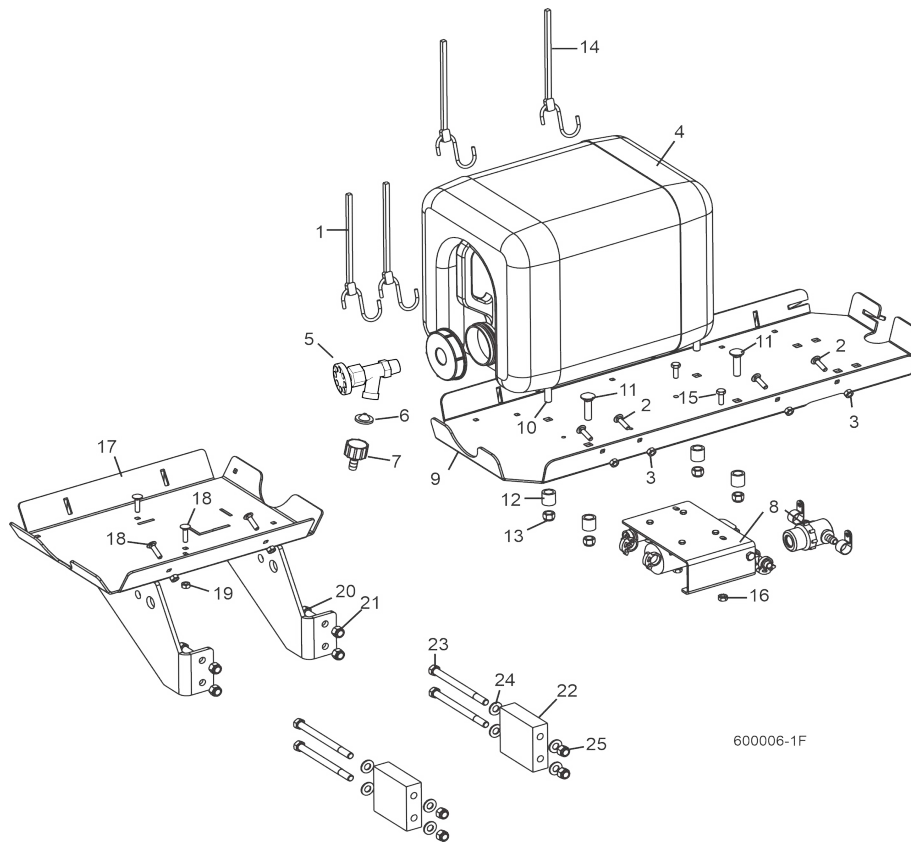

REF	PART #	DESCRIPTION	COMMENTS	QTY.
1	P11668	STRAP, 20" RUBBER		2
2	F05005-34	BOLT, 1/4-20 X 1" CARRIAGE HEAD		4
3	F05010-21	NUT, 1/4-20 HEX LOCK		4
4	014642	BOTTLE ASSEMBLY, WATER LUBE W/CAP		1
	061372 ¹	O-ring, Water Bottle Cap	If the water bottle cap keeps leaking, add this o-ring to the cap. Leave the existing o-ring installed.	1
	014636	FITTING, 3/4FPT X 3/4MPT	Removed after 9/19/2024 per ECN 38718.	1
5	133320	VALVE, 3/4 NPT ELBOW 3/4 MALE GHT OUTLET	Replaced 014100 after 9/19/2024 per ECN 38718.	1
	014100	FITTING, WATER LUBE SHUTOFF VALVE		1
6	016086	FILTER, WATER LUBE		1
7	014113	FITTING, 5/8" NPT TO 3/8" HOSE BARB		1
8		LUBEMIZER PARTS/HOSES (SEE LUBEMIZER OPTION MANUAL)		
9	S11684 ²	TRAY, WATER LUBE/FUEL TANK MOUNT (GAS/DIESEL ONLY)	See Engine Option manual for fuel tank parts.	1
10	F05007-22	BOLT, 3/8-16 X 2" CARRIAGE HEAD FULL THREAD		1
11	F05007-85	BOLT, 3/8-16 X 1 1/2" CARRIAGE HEAD GRADE 5		3

REF	PART #	DESCRIPTION	COMMENTS	QTY.
12	033911	SPACER, TANK TRAY		4
13	F05010-10	NUT, 3/8-16 HEX NYLON LOCK		4
14	P11258	STRAP, 24" RUBBER (GAS/DIESEL ONLY)		2
15	F05005-1	BOLT, 1/4-20 X 3/4" HEX HEAD FULL THREAD		2
16	F05010-9	NUT, 1/4-20 HEX SELF-LOCKING		2
17	034491	TRAY WELDMENT, WATER LUBE MOUNT (E25/E30 ONLY)		1
18	F05005-34	BOLT, 1/4-20 X 1" CARRIAGE HEAD		4
19	F05010-21	NUT, 1/4-20 HEX LOCK		4
20	F05007-7	BOLT, 3/8-16 X 1" HEX HEAD		4
21	F05010-10	NUT, 3/8-16 HEX NYLON LOCK		4
22	007660	SPACER, E30 WATERLUBE (E30 ONLY)		2
23	F05007-5	BOLT, 3/8-16 X 5" HEX HEAD		4
24	F05011-3	WASHER, 3/8" SAE FLAT		8
25	F05010-10	NUT, 3/8-16 HEX NYLON LOCK		4
	CBOTTLE	COVER, 5 GAL. WATER BOTTLE OPTIONAL (NOT SHOWN)		1

¹ Use Water Bottle Assembly w/Cap 014642 to service all bottle/cap combinations previously supplied. Bottle 014367, 61mm Cap 014773 and 70mm Cap 036744 no longer available separately.

² See Engine Option manual for fuel tank parts.

4 Saw Head

Saw Head Decals

4.8 Saw Head Decals

LT70HD

Rev. A8.00 (1/08) - B3.01

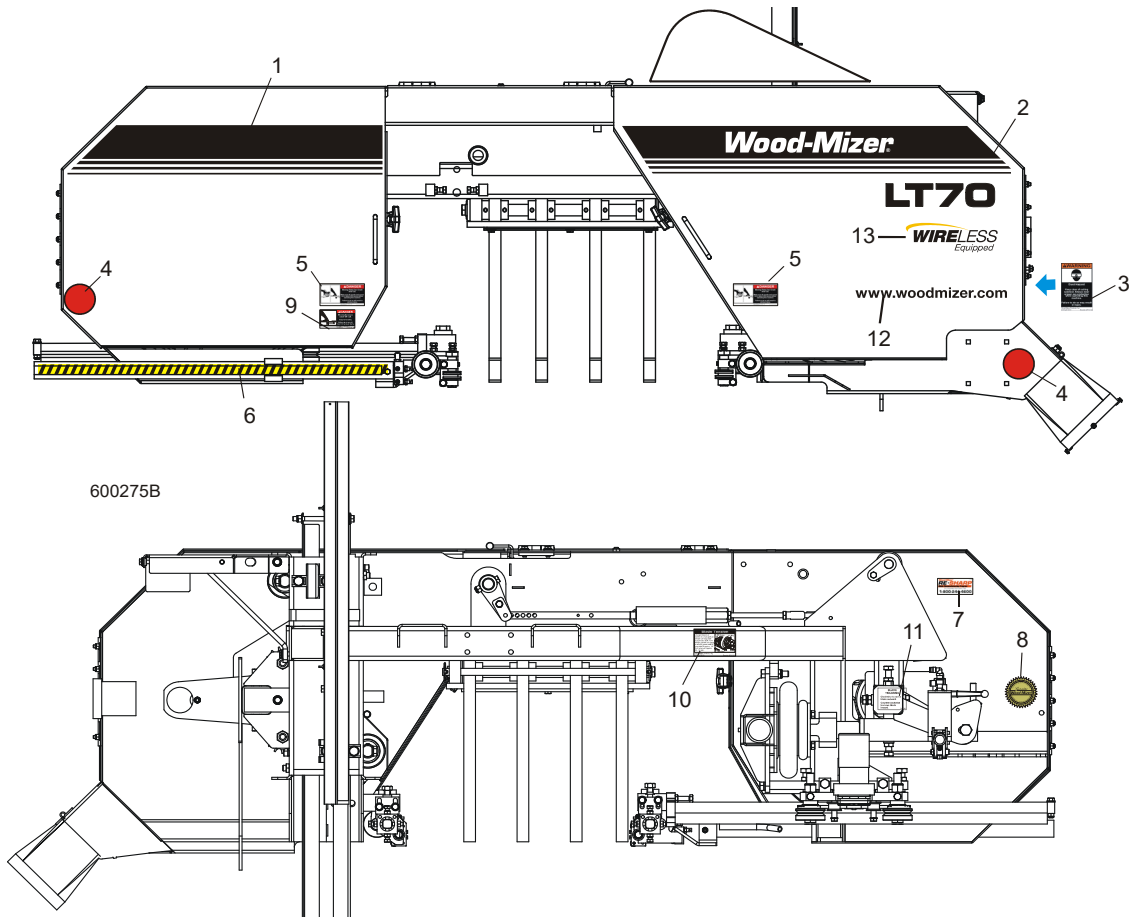

600275B

REF	DESCRIPTION (◆ Indicates Parts Available In Assemblies Only)	PART #	QTY.
1	DECAL, IDLE SIDE BLADE COVER	003249	1
2	DECAL, LT70 LOGO W/STRIPES	003248	1
3	DECAL, SAWDUST CHUTE WARNING	P11754	1
4	DECAL, RED REFLECTIVE 2" ROUND	P07452	2
5	DECAL, BLADE COVERS DANGER	033254	2
6	DECAL, BLADE GUIDE ARM STRIPE	015849	1
7	DECAL, BLADE RESHARP INFO	P12879	1
8	DECAL, WOOD-MIZER QUALITY	015930	1
9	DECAL, BLADE DANGER	S11752	1
10	DECAL, LT60/70 BLADE TENSION INFO	038596	1
11	DECAL, BLADE ALIGNMENT	P11789	1
12	DECAL, WOOD-MIZER WEBSITE	003235	1
13	DECAL, WIRELESS EQUIPPED LOGO	057782	1

4.9 Blade Housing Covers

LT60HD/70HD

Rev. B2.00 - B3.01

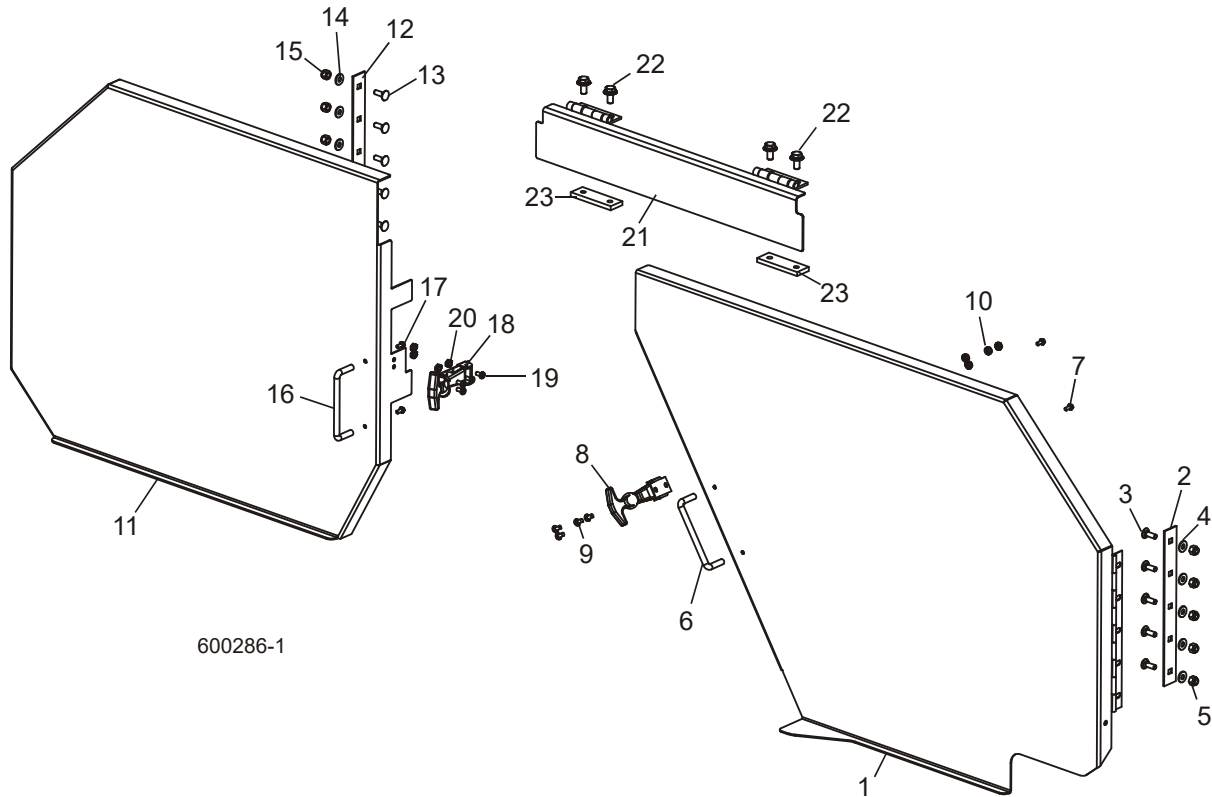

REF	DESCRIPTION (◆ Indicates Parts Available In Assemblies Only)	PART #	QTY.
	COVER ASSEMBLY, DRIVE SIDE BLADE HOUSING	048409	1
1	Cover Weldment, Drive Side Blade Housing	048403	1
2	Plate, Hinge Backing	034251	1
3	Bolt, 1/4-20 x 3/4" Carriage Head	F05005-113	5
4	Washer, 1/4" SAE Flat	F05011-11	5
5	Nut, 1/4-20 Hex Nylon Lock	F05010-69	5
6	Handle, Blade Housing Cover	P08065	1
7	Screw, #8-32 x 3/8" Self-Tapping	F05015-8	2
8	Latch, Flexible Draw	014829	1
9	Screw, #10-24 x 3/8" Cross Slotted Pan Head	F05004-3	4
10	Nut, #10-24 Hex Self-Locking	F05010-14	4
	COVER ASSEMBLY, IDLE SIDE BLADE HOUSING	036178	1
11	Cover Weldment, Idle Side Blade Housing	036176	1
12	Plate, Hinge Backing	034251	1
13	Bolt, 1/4-20 x 3/4" Carriage Head	F05005-113	5
14	Washer, 1/4" SAE Flat	F05011-11	5
15	Nut, 1/4-20 Hex Nylon Lock	F05010-69	5

4

Saw Head*Blade Housing Covers*

16	Handle, Blade Housing Cover	P08065	1	
17	Screw, #8-32 x 3/8" Self-Tapping	F05015-8	2	
18	Latch, Flexible Draw	014829	1	
19	Screw, #10-24 x 3/8" Cross Slotted Pan Head	F05004-3	4	
20	Nut, #10-24 Hex Self-Locking	F05010-14	4	
21	COVER WELDMENT, MIDDLE BLADE HOUSING	034454	1	
22	BOLT, 5/16-18 X 3/4" HEX HEAD W/FLAT & LOCK WASHER	F05006-101	4	
23	NUT PLATE, MIDDLE COVER	006810	2	

4.10 Blade Housing Covers

LT60HD/70HD

Rev. A5.00 - B1.00

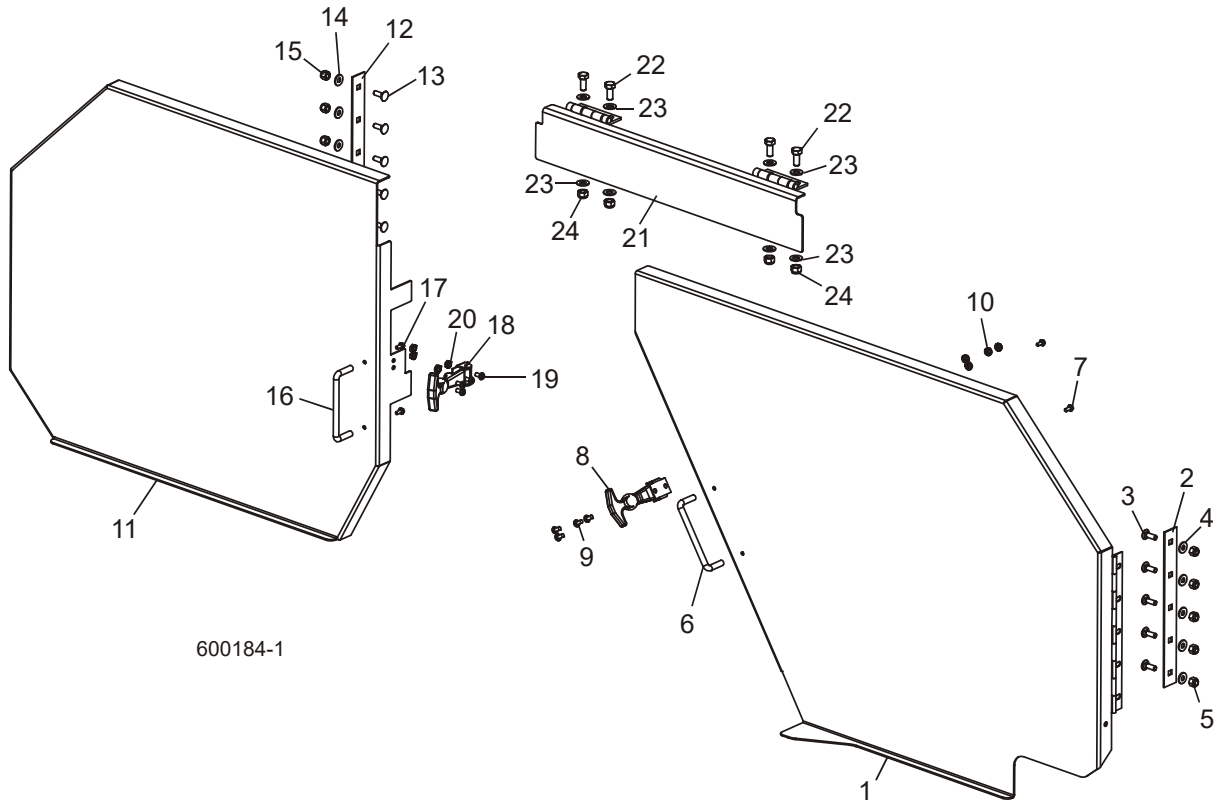

REF	DESCRIPTION (◆ Indicates Parts Available In Assemblies Only)	PART #	QTY.
	COVER ASSEMBLY, DRIVE SIDE BLADE HOUSING	048409 ¹	1
1	Cover Weldment, Drive Side Blade Housing	048403	1
2	Plate, Hinge Backing	034251	1
3	Bolt, 1/4-20 x 3/4" Carriage Head	F05005-113	5
4	Washer, 1/4" SAE Flat	F05011-11	5
5	Nut, 1/4-20 Hex Nylon Lock	F05010-69	5
6	Handle, Blade Housing Cover	P08065	1
7	Screw, #8-32 x 3/8" Self-Tapping	F05015-8	2
8	Latch, Flexible Draw	014829	1
9	Screw, #10-24 x 3/8" Cross Slotted Pan Head	F05004-3	4
10	Nut, #10-24 Hex Self-Locking	F05010-14	4
	COVER ASSEMBLY, IDLE SIDE BLADE HOUSING	036178	1
11	Cover Weldment, Idle Side Blade Housing	036176	1
12	Plate, Hinge Backing	034251	1
13	Bolt, 1/4-20 x 3/4" Carriage Head	F05005-113	5
14	Washer, 1/4" SAE Flat	F05011-11	5
15	Nut, 1/4-20 Hex Nylon Lock	F05010-69	5

4

Saw Head*Blade Housing Covers*

16	Handle, Blade Housing Cover	P08065	1	
17	Screw, #8-32 x 3/8" Self-Tapping	F05015-8	2	
18	Latch, Flexible Draw	014829	1	
19	Screw, #10-24 x 3/8" Cross Slotted Pan Head	F05004-3	4	
20	Nut, #10-24 Hex Self-Locking	F05010-14	4	
21	COVER WELDMENT, MIDDLE BLADE HOUSING	034454	1	
22	BOLT, 5/16-18 X 3/4" HEX HEAD	F05006-102	4	
23	WASHER, 5/16" SAE FLAT	F05011-17	8	
24	NUT, 5/16-18 HEX NYLON LOCK	F05010-58	4	

¹ Drive blade wheel housing revised to prevent damage from blade breakage. New Drive Side Cover Assembly 048409 fits Rev. A5.00 and later only. [See Section 4.11](#) for previous revisions.

4.11 Blade Housing Covers

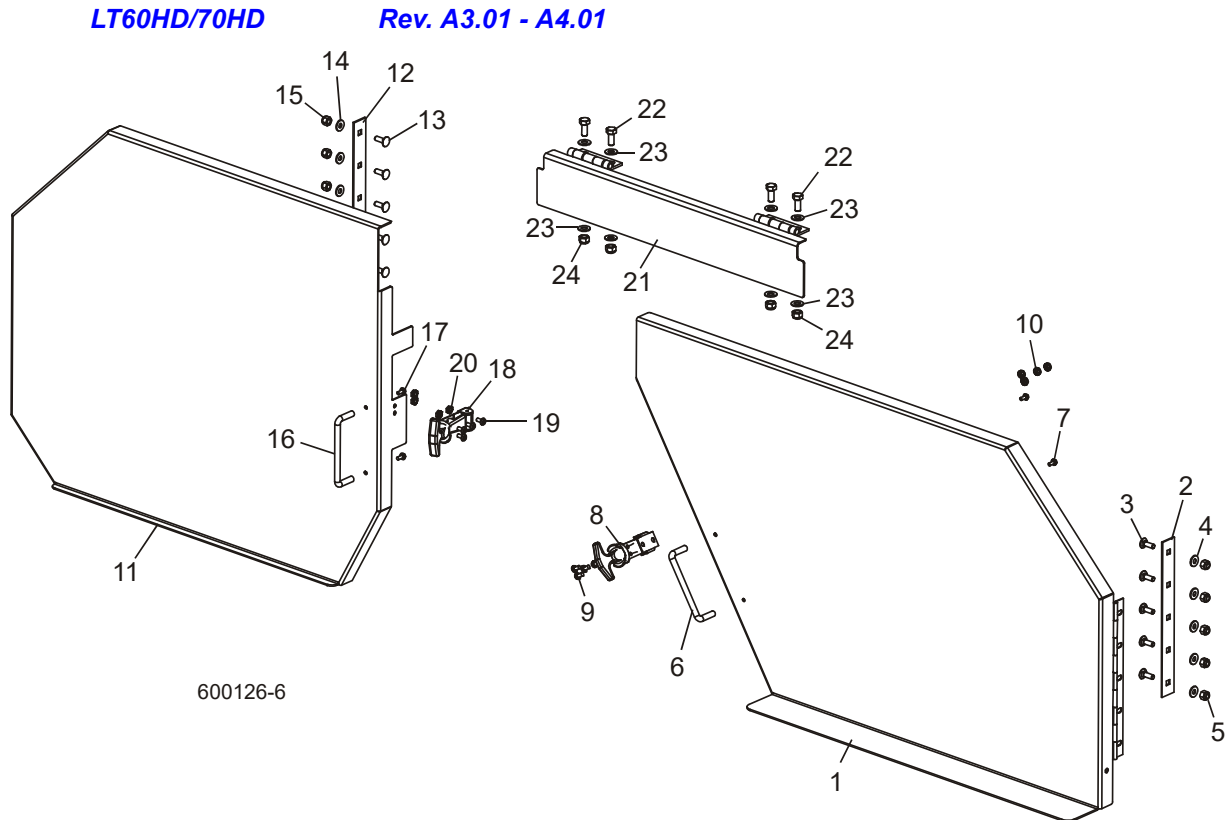

REF	DESCRIPTION (◆ Indicates Parts Available In Assemblies Only)	PART #	QTY.
	COVER ASSEMBLY, DRIVE SIDE BLADE HOUSING	036177	1
1	Cover Weldment, Drive Side Blade Housing	036175	1
2	Plate, Hinge Backing	034251	1
3	Bolt, 1/4-20 x 3/4" Carriage Head	F05005-113	5
4	Washer, 1/4" SAE Flat	F05011-11	5
5	Nut, 1/4-20 Hex Nylon Lock	F05010-69	5
6	Handle, Blade Housing Cover	P08065	1
7	Screw, #8-32 x 3/8" Self-Tapping	F05015-8	2
8	Latch, Flexible Draw	014829	1
9	Screw, #10-24 x 3/8" Cross Slotted Pan Head	F05004-3	4
10	Nut, #10-24 Hex Self-Locking	F05010-14	4
	COVER ASSEMBLY, IDLE SIDE BLADE HOUSING	036178	1
11	Cover Weldment, Idle Side Blade Housing	036176	1
12	Plate, Hinge Backing	034251	1
13	Bolt, 1/4-20 x 3/4" Carriage Head	F05005-113	5
14	Washer, 1/4" SAE Flat	F05011-11	5
15	Nut, 1/4-20 Hex Nylon Lock	F05010-69	5

4

Saw Head*Blade Housing Covers*

16	Handle, Blade Housing Cover	P08065	1	
17	Screw, #8-32 x 3/8" Self-Tapping	F05015-8	2	
18	Latch, Flexible Draw	014829	1	
19	Screw, #10-24 x 3/8" Cross Slotted Pan Head	F05004-3	4	
20	Nut, #10-24 Hex Self-Locking	F05010-14	4	
21	COVER WELDMENT, MIDDLE BLADE HOUSING	034454	1	
22	BOLT, 5/16-18 X 3/4" HEX HEAD	F05006-102	4	
23	WASHER, 5/16" SAE FLAT	F05011-17	8	
24	NUT, 5/16-18 HEX NYLON LOCK	F05010-58	4	

4.12 Sawdust Chute

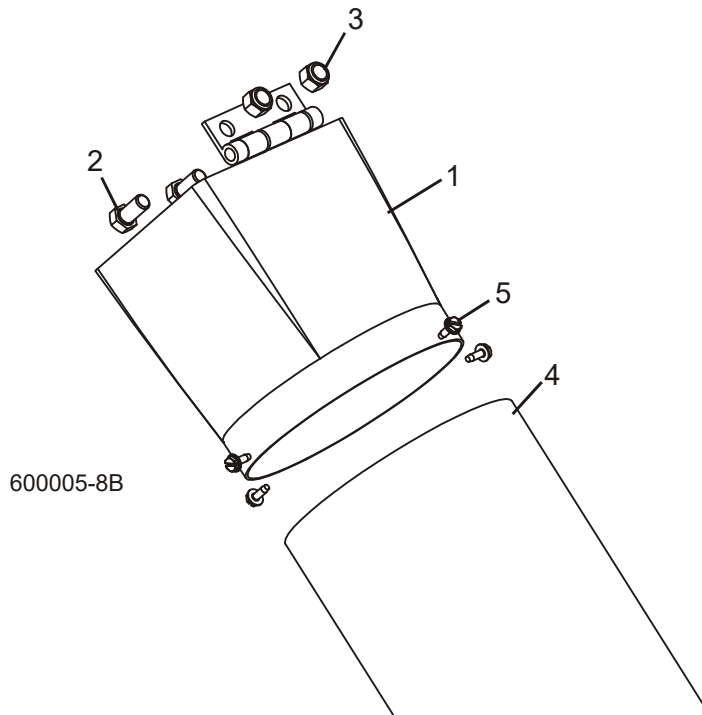

REF	DESCRIPTION (◆ Indicates Parts Available In Assemblies Only)	PART #	QTY.	
1	CHUTE WELDMENT, SAWDUST	034396	1	
2	BOLT, 3/8-16 X 3/4" HEX HEAD GRADE 5	F05007-118	2	
3	NUT, 3/8-16 HEX NYLON LOCK	F05010-10	2	
4	TUBING, RUBBER SAWDUST	017829	2	
5	BOLT, #10-24 X 1/2" SELF-TAPPING	F05015-7	4	

4 Saw Head
 Debarker Wire Box/Grommet

4.13 Debarker Wire Box/Grommet

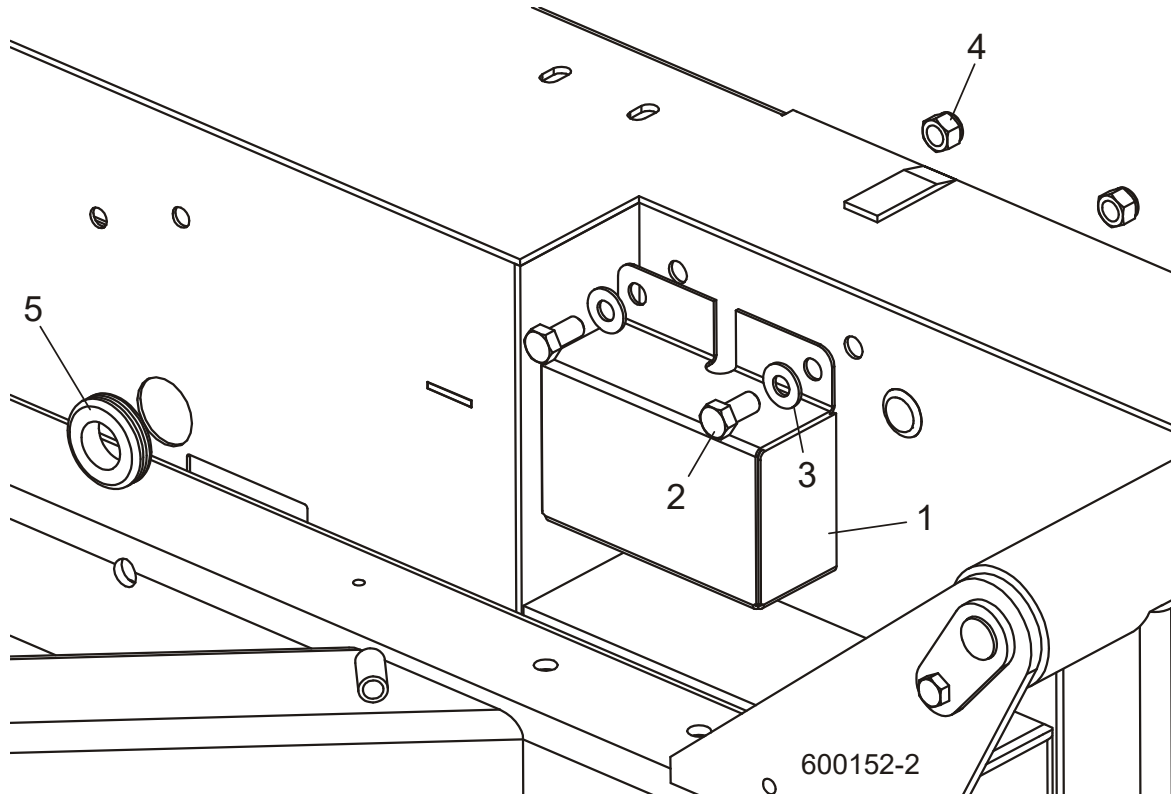

REF	DESCRIPTION (◆ Indicates Parts Available In Assemblies Only)	PART #	QTY.
1	BOX, DEBARKER WIRE STORAGE	023616	1
2	BOLT, 3/8-16 X 3/4" HEX HEAD	F05007-7	2
3	WASHER, 3/8" SAE FLAT	F05011-3	2
4	NUT, 3/8-16 HEX NYLON LOCK	F05010-10	2
5	GROMMET, 7/8" ID X 1 1/4" GROOVED OD	P702	1

SECTION 5 CONTROL & BATTERY BOXES

5.1 Control Assembly (DC)

LT70HD

Rev. B3.00 - B3.01

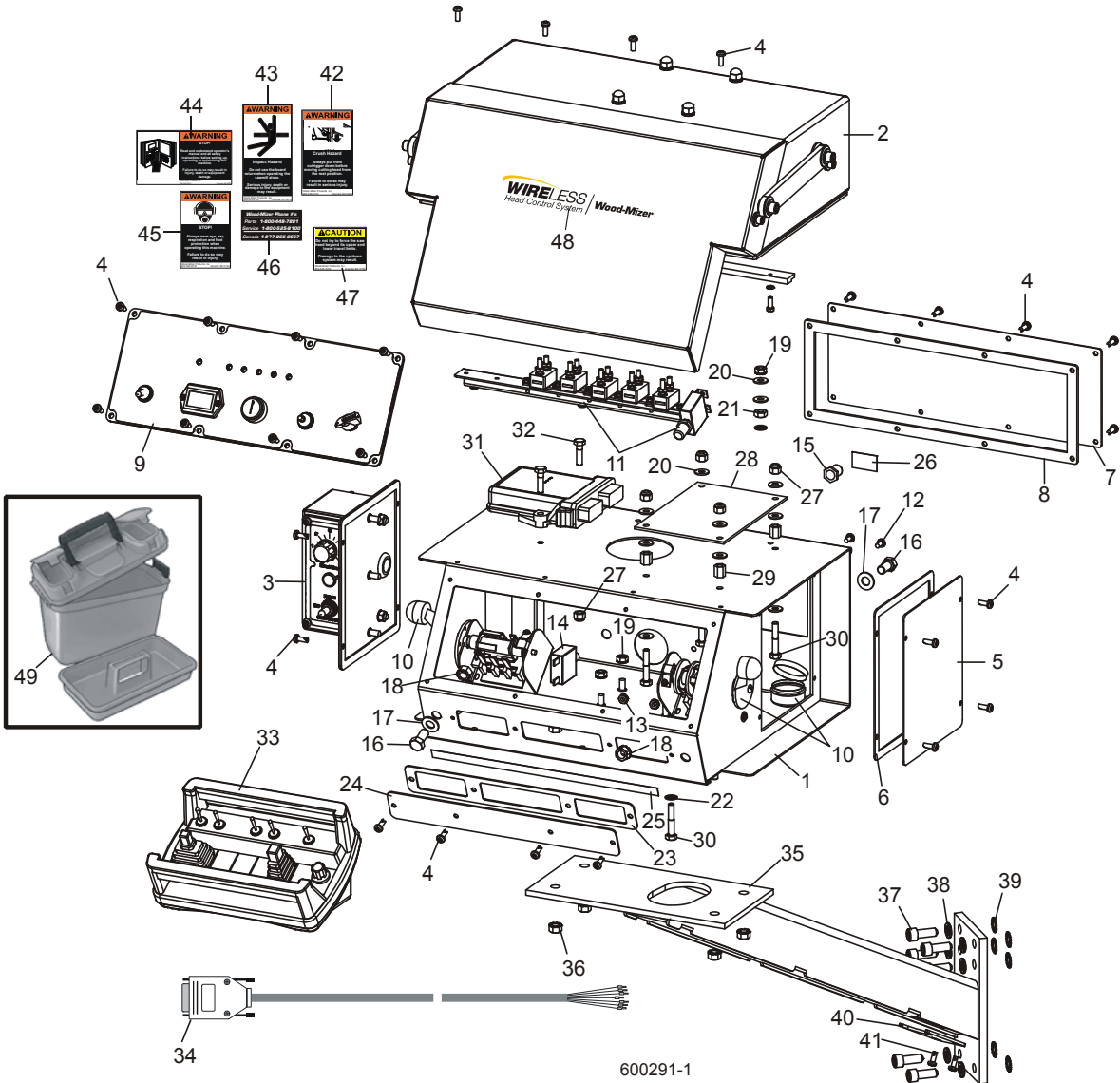

REF	DESCRIPTION (◆ Indicates Parts Available In Assemblies Only)	PART #	QTY.	
	COVER, SAWMILL CONTROL CONSOLE W/ACCUSSET	036352	1	
	CONTROL BOX ASSEMBLY, D55 WIRELESS	053281	1	
	CONTROL BOX ASSEMBLY, D51/D62 WIRELESS	053357	1	
1	Box Weldment, Sawmill Control	057817	1	◆
2	Accuset Control Parts (See Accuset 2 option manual)			
3	LubeMizer Parts (See LubeMizer option manual)			

5

Control & Battery Boxes*Control Assembly (DC)*

4	Screw, #10-24 x 1/2" Pan Head	F05015-17	32	
5	Panel Weldment, Side	006473	1	
6	Gasket, Side Panel Control	015274	1	
7	Plate, Rear Control Box	016230	1	
8	Gasket, Rear Panel	015278	1	
9	Front Control Panel & Wiring Harnesses (See Section 8.6)			
10	Drum Switches (See Section 6.4)			
11	Circuit Breakers (See Section 6.5)			
12	Screw, #10-24 x 3/8" Phillips Pan Head	F05004-3	2	
13	Nut, #10-24 Hex Self-Locking	F05010-14	2	
14	Breaker, 30A Manual Reset Panel Mount	024246	1	
15	Boot, Circuit Breaker	021253	1	
16	Bolt, 3/8-16 x 3/4" Hex Head	F05007-27	2	
17	Washer, 3/8" SAE Flat	F05011-3	2	
18	Nut, 3/8" Lock Nut	F05010-19	2	
19	Nut, 1/4-20 Self Locking	F05010-9	3	
20	Washer, 1/4 SAE Flat	F05011-11	14	
21	Nut, 1/4-20 Heavy-Duty Hex Jam	F05010-129	1	
22	Washer, 1/4" Interior Star Heavy-Duty Lock	F05011-69	2	
23	Gasket, Front Access Panel	015266	1	
24	Panel, Control Box Front Access	015376	1	
25	Decal, Circuit Breaker ID (LT70 2009)	053354	1	
26	Decal, Circuit Breaker ID (Autoclutch)	024366	1	
27	Nut, 1/4-20 Hex Nylon Lock	F05010-69	6	
28	PCB Assembly, Sawmill Wireless Interface	053148	1	
	Relay, 12A 12VDC DPDT	053144	7	
	Fuse, 10A ATO Blade Red	024150-10	1	
29	Standoff, 1/4 x 20 Female Threaded	053149	4	
30	Bolt, 1/4-20 x 1 1/2" Hex Head Full Thread	F05005-31	5	
31	Receiver Kit, Wireless R160 w/Instructions	053218	1	
32	Screw, 1/4-20 x 1" Hex Head	F05005-38	2	
33	Transmitter Kit, Wireless T300 w/Instructions	053217	1	
	Switch Kit, Omnex T300 Replacement E-Stop	053638	1	
	Switch Kit, Omnex T300 DT Momentary Toggle	053639	1	
	Switch Kit, Omnex T300 ST Maintained Toggle	053640	1	
	Switch Kit, Omnex T300 Variable Feed Potentiometer	053641	1	
	Switch Kit, Omnex T300 Up/Down Paddle	053642	1	
	Switch Kit, Omnex T300 Fwd/Rev/BG In-Out Joystick	053643	1	
	Harness, Wireless T300 Transmitter Orange Tear Away	053159	1	
34	Harness Assembly, Dual-Axis Motor Control Non-Remote	053355	1	
35	MOUNT WELDMENT, STANDARD CONTROL BOX	015236	1	
36	NUT, 5/16-18 SELF-LOCKING HEX	F05010-20	4	
37	BOLT, 3/8-16 X 1" SOCKET HEAD	F05007-52	4	

38	WASHER, 3/8" SPLIT LOCK	F05011-4	4	
39	WASHER, 3/8" EXTERIOR STAR LOCK	F05011-36	4	
40	PLATE, PEDESTAL COVER	036381	1	
41	SCREW, #10-24 X 1/2" PAN HEAD	F05015-17	2	
42	DECAL, FRONT OUTRIGGER WARNING	015400	1	
43	DECAL, BOARD RETURN WARNING	016072	1	
44	DECAL, READ MANUAL WARNING	016402	1	
45	DECAL, EAR/EYE PROTECTION WARNING	S11753	1	
46	DECAL, 800 NUMBER	S12117	1	
47	DECAL, UP/DOWN CAUTION	S11762	1	
48	DECAL, WIRELESS HEAD CONTROL SYSTEM LOGO	057781	1	
49	BOX, PLASTIC WIRELESS CONTROL STORAGE	006472	1	

5 Control & Battery Boxes

Control Assembly (AC)

5.2 Control Assembly (AC)

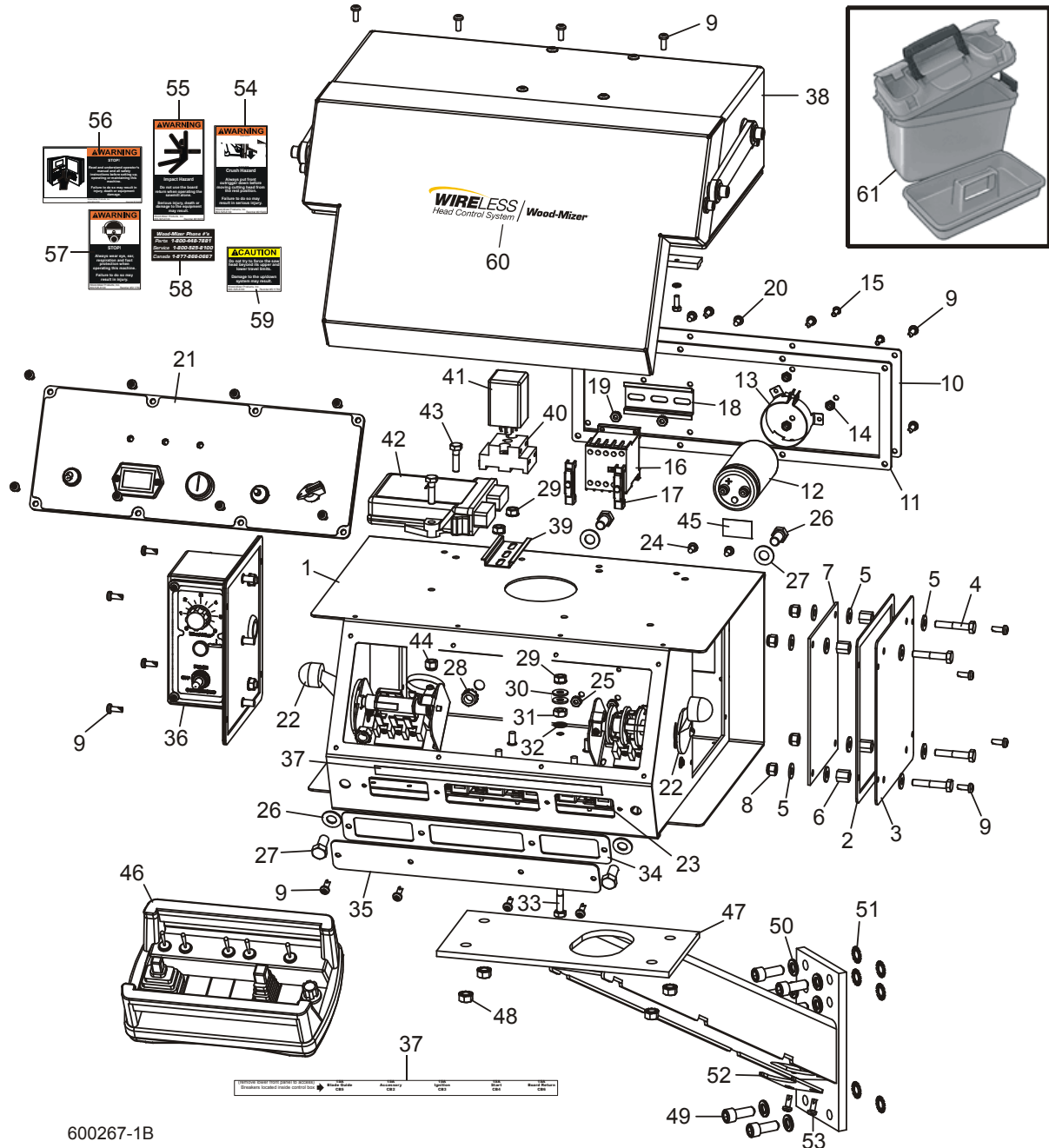

600267-1B

REF	DESCRIPTION (◆ Indicates Parts Available In Assemblies Only)	PART #	QTY.
	COVER, SAWMILL CONTROL CONSOLE W/ACCUNET	036352	1
	CONTROL BOX ASSEMBLY, E25	053189	1
1	Box Weldment, Wireless AC Sawmill Control	057817	1
	Panel Assembly, Wireless AC Sawmill Side	053150	1

2	Gasket, Side Access Panel	015274	1	
3	Panel Weldment, Side Access	057799	1	
4	Bolt, 1/4-20 x 1 1/2 Hex Head Full Thread	F05005-31	4	
5	Washer, 1/2" SAE Flat	F05011-11	12	
6	Standoff, 1/4" x 20 Female Threaded	053149	4	
7	PCB Assembly, Sawmill Wireless Interface	053148	1	
	Relay, 12A 12VDC DPDT	053144	7	
	Fuse, 10A ATO Blade Red	024150-10	1	
8	Nut, 1/4-20 Nylon Lock	F05010-69	4	
9	Screw, #10-24 x 1/2" Pan Head	F05015-17	32	
10	Panel, Rear Control Access	016230	1	
	Panel Assembly, Wireless AC Sawmill Back	053153	1	
11	Panel, Wireless Rear Control	057797	1	
12	Gasket, Rear Access Panel	015278	1	
13	Capacitor, 9600uF 40VDC	053152	1	
14	Bracket, Capacitor Mounting	053151	1	
15	Nut, #8-32 Hex Nylon Lock	F05010-169	3	
16	Relay, Control 2 NO 2NC 12VDC Low Power	050807	1	
17	Clamp, Plastic Din Rail	E22707	2	
18	Din Rail, 35mm x 7.5mm x 3" Steel	024474-3	1	
19	Nut, #10-24 Keps	F05010-14	2	
20	Screw, #10-24 x 3/8" Phillips	F05004-3	2	
21	Front Control Panel (Section 8.6)			
22	Drum Switches (Section 6.4)			
23	Circuit Breakers (Section 6.5)			
24	Screw, #10-24 x 3/8" Phillips Pan Head	F05004-3	2	
25	Nut, #10-24 Self Locking	F05010-14	2	
26	Bolt, 3/8-16 x 3/4" Hex Head	F05007-27	4	
27	Washer, 3/8" SAE Flat	F05011-3	4	
28	Nut, 3/8" Lock Nut	F05010-19	4	
29	Nut, 1/4-20 Self Locking	F05010-9	3	
30	Washer, 1/4" SAE Flat	F05011-11	2	
31	Nut, 1/4-20 Jam Heavy Duty	F05010-129	2	
32	Washer, 1/4" Interior Star Heavy Duty	F05011-69	1	
33	Bolt, 1/4-20 x 1 1/2" Hex Head Full Thread	F05005-31	1	
34	Gasket, Front Access Panel	015266	1	
35	Panel, Control Box Front Access	015376	1	
36	LubeMizer Control Parts (See LubeMizer Manual)			
37	Decal, Circuit Breaker ID	050917	1	
	Decal, Circuit Breaker ID (Debarker In/Out)	050918	1	
38	Accuset Control Parts (See Accuset Manual)			
39	Din Rail, 35mm x 7.5mm x 3" Steel	024474-3	1	
40	Socket, 8 Pin Relay	E10216	1	

5 Control & Battery Boxes

Control Assembly (AC)

41	Relay, DPDT 10A GP Tube Terminals	050300	1	
42	Receiver Kit, Wireless R160 w/Instructions	053218	1	
43	Screw, 1/4-20 x 1" Hex Head	F05005-38	2	
44	Screw, 1/4-20 Nylon Lock	F05010-69	2	
45	Decal, Breaker ID LT70E25 Debarker	050918	1	
46	Transmitter Kit, Wireless T300 w/Instructions	053217	1	
	Switch Kit, Omnex T300 Replacement E-Stop	053638	1	
	Switch Kit, Omnex T300 DT Momentary Toggle	053639	1	
	Switch Kit, Omnex T300 ST Maintained Toggle	053640	1	
	Switch Kit, Omnex T300 Variable Feed Potentiometer	053641	1	
	Switch Kit, Omnex T300 Up/Down Paddle	053642	1	
	Switch Kit, Omnex T300 Fwd/Rev/BG In-Out Joystick	053643	1	
	Harness, Wireless T300 Transmitter Orange Tear Away	053159	1	
	Harness Parts (See Section 8.6)			
47	MOUNT WELDMENT, STANDARD CONTROL BOX	015236	1	
48	NUT, 5/16-18 SELF-LOCKING HEX	F05010-20	4	
49	BOLT, 3/8-16 X 1" SOCKET HEAD	F05007-52	4	
50	WASHER, 3/8" SPLIT LOCK	F05011-4	4	
51	WASHER, 3/8" EXTERIOR STAR LOCK	F05011-36	4	
52	PLATE, PEDESTAL COVER	036381	1	
53	SCREW, #10-24 X 1/2" PAN HEAD	F05015-17	2	
54	DECAL, FRONT OUTRIGGER WARNING	015400	1	
55	DECAL, BOARD RETURN WARNING	016072	1	
56	DECAL, READ MANUAL WARNING	016402	1	
57	DECAL, EAR/EYE PROTECTION WARNING	S11753	1	
58	DECAL, 800 NUMBER	S12117	1	
59	DECAL, UP/DOWN CAUTION	S11762	1	
60	DECAL, WIRELESS HEAD CONTROL SYSTEM LOGO	057781	1	
61	BOX, PLASTIC WIRELESS CONTROL STORAGE	006472	1	

5.3 Control Assembly (DC)

LT70HD

Rev. A9.00 - B2.00

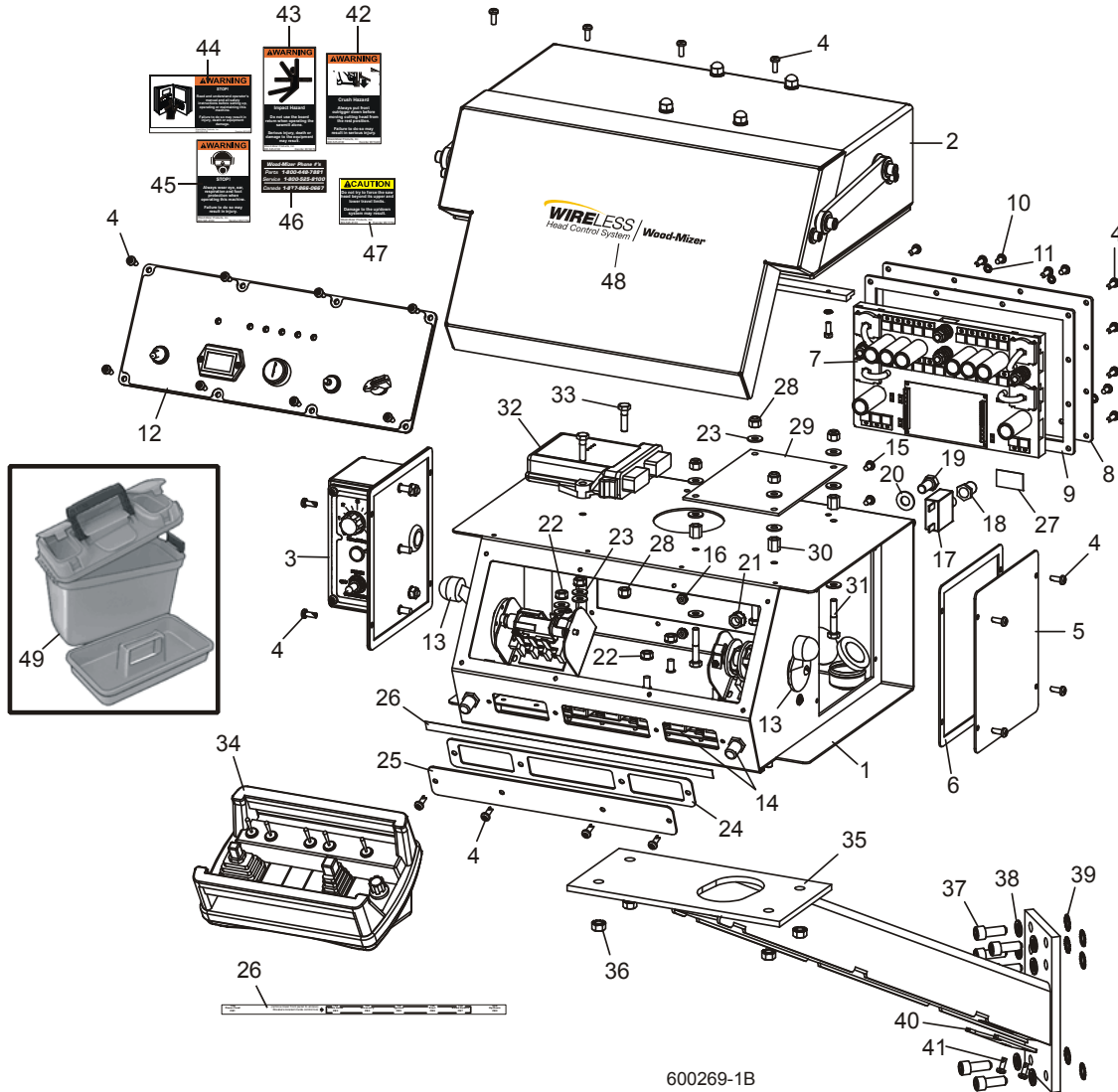

REF	DESCRIPTION (◆ Indicates Parts Available In Assemblies Only)	PART #	QTY.	
	COVER, SAWMILL CONTROL CONSOLE W/ACCUSSET	036352	1	
	CONTROL BOX ASSEMBLY, D51/D62 SOFTSTART WIRELESS	053187	1	
1	Box Weldment, Sawmill Control	047930	1	◆
2	Accuset Control Parts (See Accuset 2 option manual)			
3	LubeMizer Parts (See LubeMizer option manual)			
4	Screw, #10-24 x 1/2" Pan Head	F05015-17	36	
5	Panel Weldment, Side	015307	1	
6	Gasket, Side Panel Control	015274	1	
	Panel Assembly, Power Feed Control	051887 ¹	1	◆
7	Control Module, Power Feed	051667	1	◆

5

Control & Battery Boxes

Control Assembly (DC)

8	Plate, Power Feed Module	047698	1	
9	Gasket, Rear Panel	047938	1	
10	Screw, #10-24 x 3/8" Phillips Pan Head	F05004-3	6	
11	Washer, #10 Split Lock	F05011-20	6	
12	Front Control Panel & Wiring Harnesses (See Section 8.6)			
13	Drum Switches (See Section 6.4)			
14	Circuit Breakers (See Section 6.5)			
15	Screw, #10-24 x 3/8" Phillips Pan Head	F05004-3	2	
16	Nut, #10-24 Self Locking	F05010-14	2	
17	Breaker, 30A Manual Reset Panel Mount	024246	1	
18	Boot, Circuit Breaker	021253	1	
19	Bolt, 3/8-16 x 3/4" Hex Head	F05007-27	1	
20	Washer, 3/8" SAE Flat	F05011-3	1	
21	Nut, 3/8" Lock Nut	F05010-19	1	
22	Nut, 1/4-20 Self Locking	F05010-9	5	
23	Washer, 1/4 SAE Flat	F05011-11	16	
24	Gasket, Front Access Panel	015266	1	
25	Panel, Control Box Front Access	015376	1	
26	Decal, Circuit Breaker ID	052834	1	
27	Decal, Circuit Breaker ID (Autoclutch)	024366	1	
28	Nut, 1/4-20 Nylon Lock	F05010-69	6	
29	PCB Assembly, Sawmill Wireless Interface	053148	1	
	Relay, 12A 12VDC DPDT	053144	7	
	Fuse, 10A ATO Blade Red	024150-10	1	
30	Standoff, 1/4 x 20 Female Threaded	053149	4	
31	Bolt, 1/4-20 x 1 1/2" Hex Head Full Thread	F05005-31	4	
32	Receiver Kit, Wireless R160 w/Instructions	053218	1	
33	Screw, 1/4-20 x 1" Hex Head	F05005-38	2	
34	Transmitter Kit, Wireless T300 w/Instructions	053217	1	
	Switch Kit, Omnex T300 Replacement E-Stop	053638	1	
	Switch Kit, Omnex T300 DT Momentary Toggle	053639	1	
	Switch Kit, Omnex T300 ST Maintained Toggle	053640	1	
	Switch Kit, Omnex T300 Variable Feed Potentiometer	053641	1	
	Switch Kit, Omnex T300 Up/Down Paddle	053642	1	
	Switch Kit, Omnex T300 Fwd/Rev/BG In-Out Joystick	053643	1	
	Harness, Wireless T300 Transmitter Orange Tear Away	053159	1	
35	MOUNT WELDMENT, STANDARD CONTROL BOX	015236	1	
36	NUT, 5/16-18 SELF-LOCKING HEX	F05010-20	4	
37	BOLT, 3/8-16 X 1" SOCKET HEAD	F05007-52	4	
38	WASHER, 3/8" SPLIT LOCK	F05011-4	4	
39	WASHER, 3/8" EXTERIOR STAR LOCK	F05011-36	4	
40	PLATE, PEDESTAL COVER	036381	1	
41	SCREW, #10-24 X 1/2" PAN HEAD	F05015-17	2	

42	DECAL, FRONT OUTRIGGER WARNING	015400	1	
43	DECAL, BOARD RETURN WARNING	016072	1	
44	DECAL, READ MANUAL WARNING	016402	1	
45	DECAL, EAR/EYE PROTECTION WARNING	S11753	1	
46	DECAL, 800 NUMBER	S12117	1	
47	DECAL, UP/DOWN CAUTION	S11762	1	
48	DECAL, WIRELESS HEAD CONTROL SYSTEM LOGO	057781	1	
49	BOX, PLASTIC WIRELESS CONTROL STORAGE	006472	1	

¹ Power Feed Module 051887 discontinued 12/10. Use kit 069459 to retrofit Accuset 2 for dual-axis control of power feed motor. If Accuset 2 is older than Rev. B.00 with original part 052974 single-axis control module (No MOT2A or MOT2B terminal studs), a new dual-axis module 057821LS-FR is required in addition to kit 069459.

5.4 Drum Switches

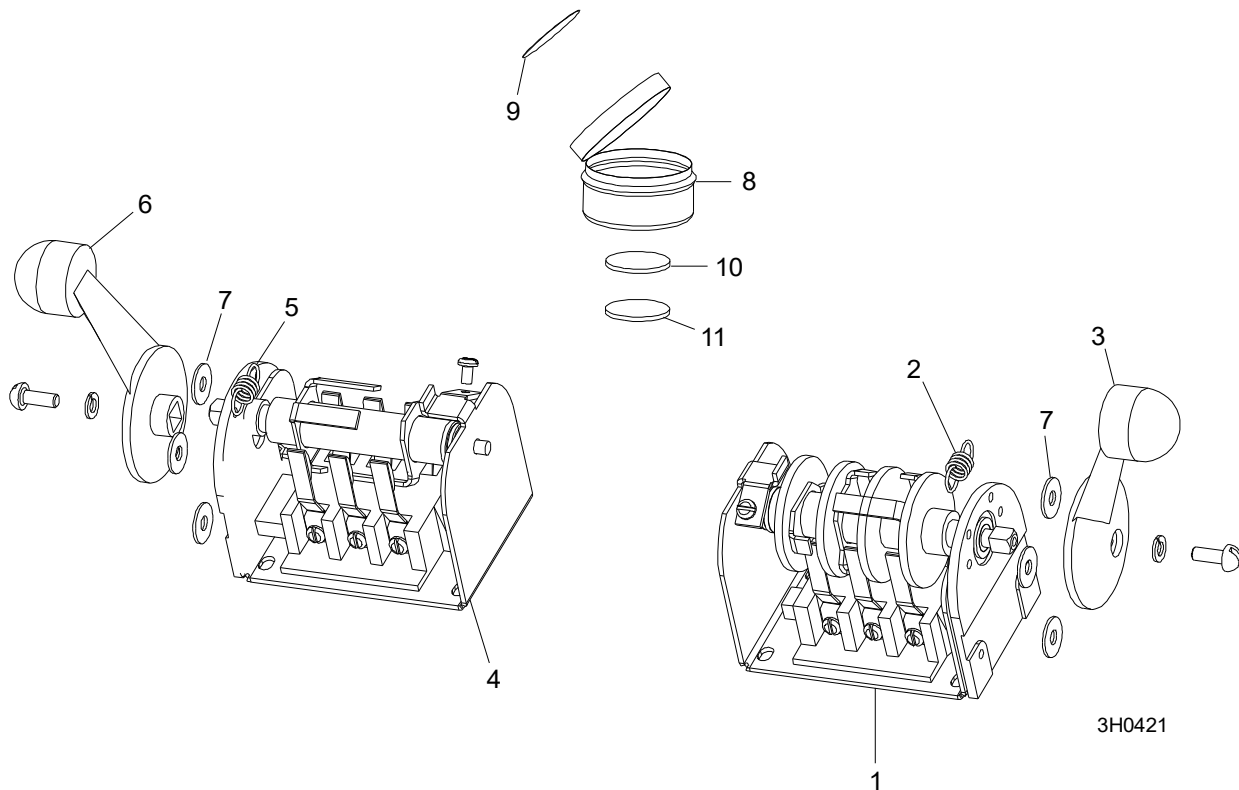

REF	DESCRIPTION (◆ Indicates Parts Available In Assemblies Only)	PART #	QTY.	
	SWITCH ASSEMBLY, UP/DOWN DRUM	E20440	1	
1	Switch, S12 Bulk Drum	E20440-B	1	◆
2	Spring, Drum Switch	P12570	1	
3	Handle, Drum Switch Replacement	P12500	1	
	SWITCH ASSEMBLY, POWER FEED DRUM	E20439	1	
4	Switch, S11 Bulk Drum	E20439-B	1	◆
5	Spring, Drum Switch	P12570	1	
6	Handle, Drum Switch Replacement	P12500	1	
7	WASHER, #8 SAE FLAT	F05011-41	6	
	CUP ASSEMBLY, DRUM SWITCH GREASE	A20463	1	
8	Cup, Plastic Container	P20464	1	◆
9	Decal, Grease Cup Label	P20467	1	
10	Pad, Velcro Loop	P20466	1	◆
11	Pad, Velcro Hook	P20465	1	◆
	Grease, High Temp Drum Switch	P20468	.025 Lb	◆

5.5 Circuit Breakers

LT60HD
LT70HD

Rev. B3.00 - B3.01
Rev. B3.00 - B3.01

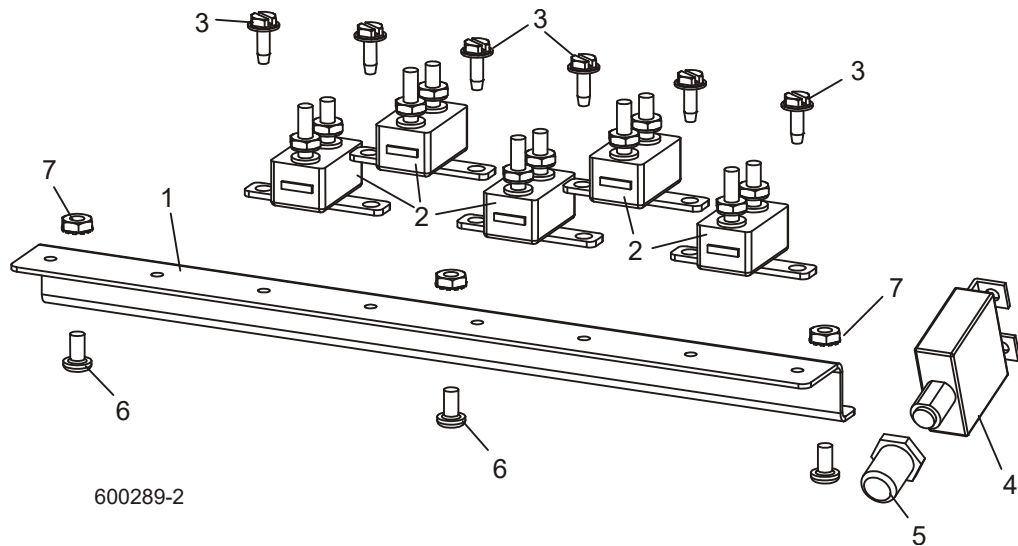

REF	DESCRIPTION (◆ Indicates Parts Available In Assemblies Only)	PART #	QTY.
	BREAKER ASSEMBLY, SAWMILL CONTROL CIRCUIT (DC)	015621	1
	BREAKER ASSEMBLY, SAWMILL CONTROL CIRCUIT (AC)	050916	1
1	Rail, Circuit Breaker	052826	1
2	Breaker, 15 Amp Manual Reset	E20430	5
3	Screw, #10-24 x 1/2" Self-Tapping	F05015-7	6
4	BREAKER, 70 AMP MANUAL RESET PANEL MOUNT (DC ONLY)	015527	1
5	BOOT, CIRCUIT BREAKER	021253	1
6	SCREW, #10-24 X 3/8" PHILLIPS PAN HEAD	F05004-3	3
7	NUT, #10-24 SELF LOCKING	F05010-14	3

5.6 Circuit Breakers

LT60HD
LT70HD

Rev. A7.08 - B2.00
Rev. A7.08 - B2.00

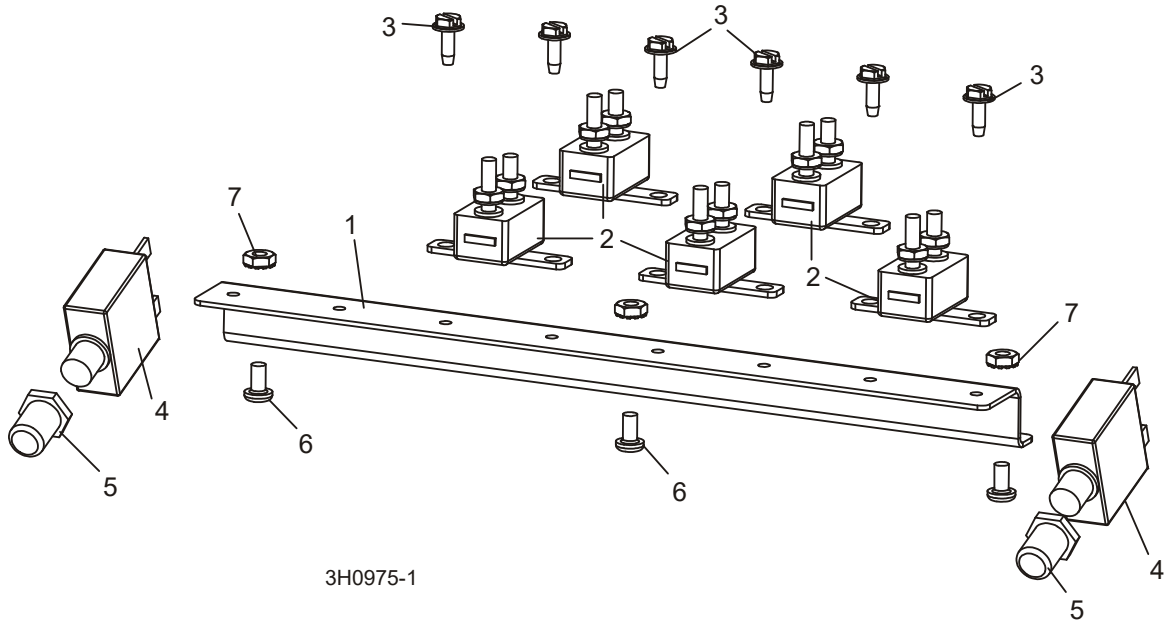

REF	DESCRIPTION (◆ Indicates Parts Available In Assemblies Only)	PART #	QTY.
	BREAKER ASSEMBLY, SAWMILL CONTROL CIRCUIT (DC)	015621	1
	BREAKER ASSEMBLY, SAWMILL CONTROL CIRCUIT (AC)	050916	1
1	Rail, Circuit Breaker	052826	1
2	Breaker, 15 Amp Manual Reset	E20430	5
3	Screw, #10-24 x 1/2" Self-Tapping	F05015-7	6
4	BREAKER, 70 AMP MANUAL RESET PANEL MOUNT (DC ONLY)	015527	2
5	BOOT, CIRCUIT BREAKER	021253	2
6	SCREW, #10-24 X 3/8" PHILLIPS PAN HEAD	F05004-3	3
7	NUT, #10-24 SELF LOCKING	F05010-14	3

5.7 Circuit Breakers

LT60HD
LT70HD

Rev. A3.01 - A7.07
Rev. A3.01 - A7.07

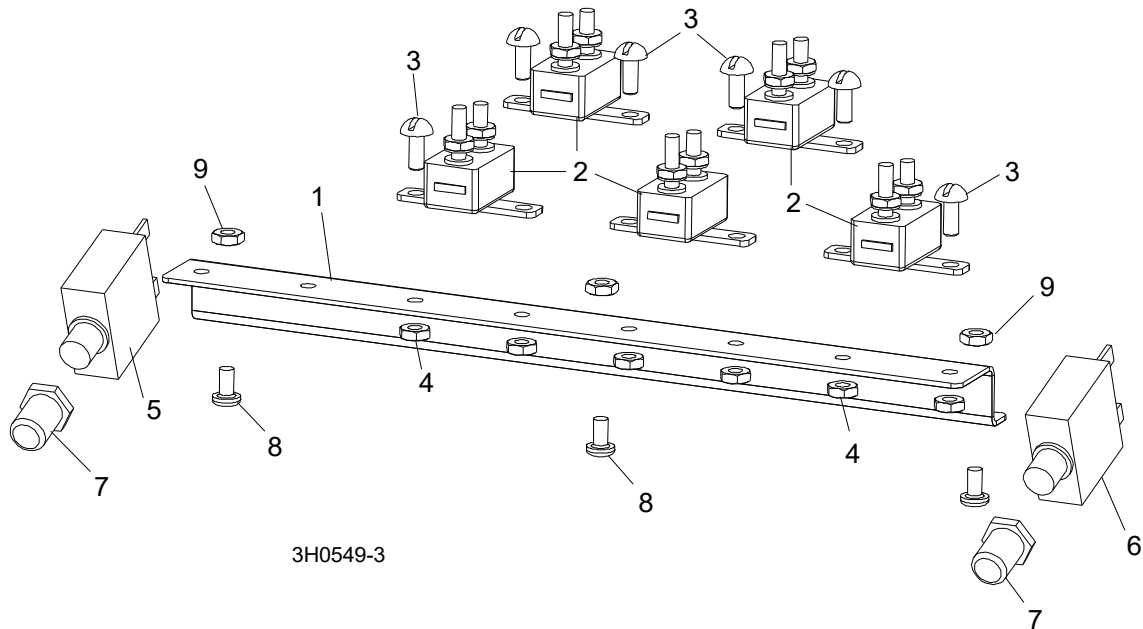

REF	DESCRIPTION (◆ Indicates Parts Available In Assemblies Only)	PART #	QTY.
	BREAKER ASSEMBLY, SAWMILL CONTROL CIRCUIT (DC)	015621 ¹	1
	BREAKER ASSEMBLY, SAWMILL CONTROL CIRCUIT (AC)	050916 ¹	1
1	Rail, Circuit Breaker	015310	1
2	Breaker, 15 Amp Manual Reset	E20430	5
3	Screw, #8-32 X 1/2" Slotted Head	F05004-12	6
4	Nut, #8-32 Hex Self-Locking	F05010-41	6
5	BREAKER, 70 AMP MANUAL RESET PANEL MOUNT (DC ONLY)	015527	1
6	BREAKER, 50 AMP MANUAL RESET PANEL MOUNT (DC ONLY)	021256 ²	1
7	BOOT, CIRCUIT BREAKER	021253	2
8	SCREW, #10-24 X 3/8" PHILLIPS PAN HEAD	F05004-3	3
9	NUT, #10-24 SELF LOCKING	F05010-14	3

¹ Circuit Breaker Assembly modified 12/06. New rail 052826 used to accept self-tapping screws ([See Section 5.6](#)).

² 70A Breaker 015527 replaces 50A Breaker 021256 for Up/Down Circuit to reduce nuisance tripping (12/06). Use kit 052866 to retrofit (includes Circuit Breaker ID decal 052834).

5.8 Front Panel Assembly & Harnesses

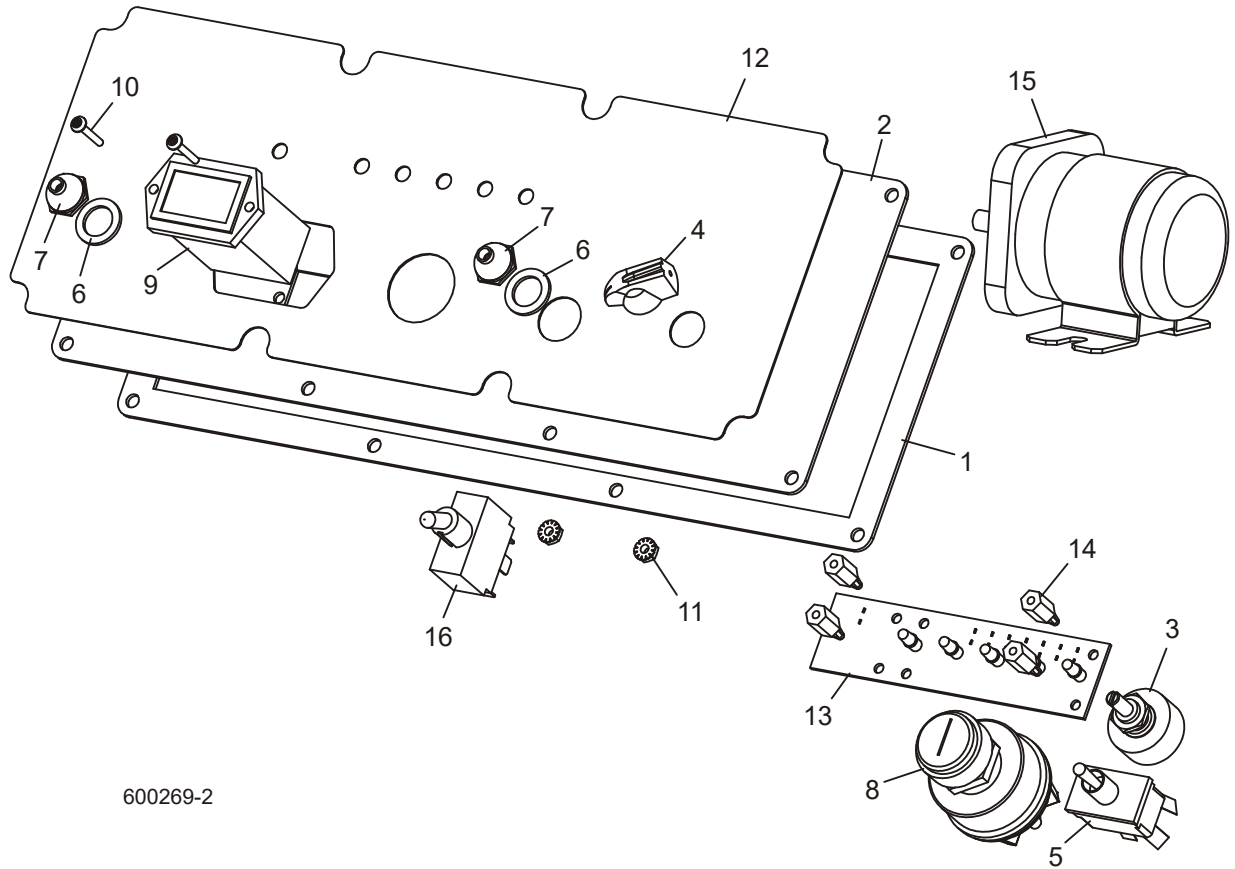

600269-2

REF	DESCRIPTION (◆ Indicates Parts Available In Assemblies Only)	PART #	QTY.
	PANEL ASSEMBLY, CONTROL FRONT D51/D55/D62	051877	1
	PANEL ASSEMBLY, CONTROL FRONT E25	050299	1
1	Gasket, Front Panel	015270	1
2	Panel Weldment, Control	015302	1
3	Switch Assembly, Feed Rate	024450-1	1
4	Knob, Feed Rate With Set Screw	P06257	1
5	Switch, Toggle	024200	1
6	Boot, Toggle Switch Rubber	P02575	2
7	Washer, 12 x 3/4 x 1/16 Nylon	P05251-1	2
8	Switch, Key	P04350	1
9	Meter, Hour	015401	1
10	Screw, 6-42 x 3/4" Socket Button Head Cap Stainless Steel	F05004-93	2
11	Nut, 6-32 Self Locking	F05010-59	2
12	Decal, Control Panel (E25)	015271	1
	Decal, Control Panel (D47/D51/D55/D62)	015269	1

13	Board, LED Circuit (E25)	015416	1	
	Board, LED Circuit (D47/D51/D55/D62)	015409	1	
14	Spacer, 1/2"-#6 Threaded	023147	4	
15	Solenoid Kit, 200A 12V SPST Cont. Duty	016371	1	
	Solenoid, 200A 12V SPST Cont. Duty	015470	1	◆
	Diode Assembly, Solenoid Coil Chassis Gnd	015426	1	
	Fuse Assembly, 2004 ATO w/Holder	051871	1	
	Fuse, 4A ATO Blade Pink	024150-4	1	
16	Switch, Blade Start/Stop	051346	1	
	HARNESS ASSEMBLY, UPPER WIRING (D55)	053282	1	
	HARNESS ASSEMBLY, UPPER WIRING (D51/D62)	052229	1	
	HARNESS ASSEMBLY, UPPER WIRING (E25)	053197	1	
	Conduit, 1 1/4" x 58" Flex	050399	1	
	Connector, 1 1/4" Straight Male Metal Conduit	024402	1	
	Cable Assembly, AC LT70 Power Feed Service (E25 Only)	052859	1	
	Cable Assembly, AC Drive Interface (E25 Only)	053192	1	
	HARNESS ASSEMBLY, LOWER WIRING	051872	1	
	Conduit, 1/2" Expandable Black	R02374	41 in.	
	Conduit, 1/2" Expandable Black	R02374	42 in.	

5.9 Battery Box Assembly (DC Only)

LT60HD/70HD

Rev. B3.00 - B3.01

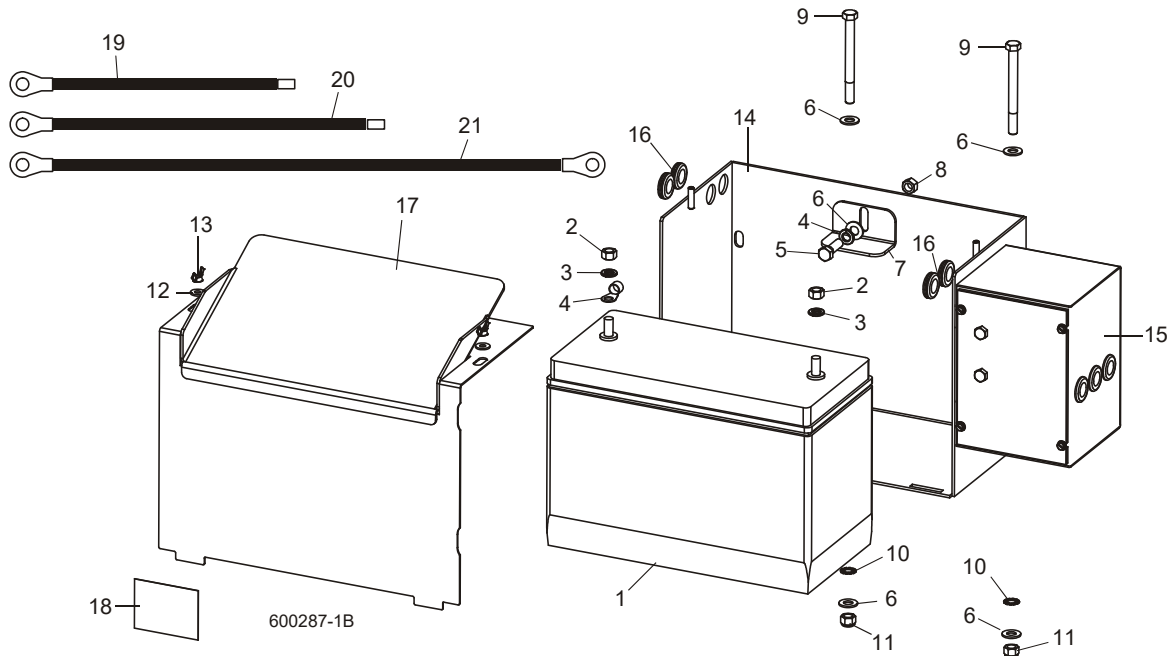

REF	DESCRIPTION (◆ Indicates Parts Available In Assemblies Only)	PART #	QTY.	
1	BATTERY, 12 VOLT	015475	1	◆
	BOX ASSEMBLY, LT60/70 BATTERY	017674	1	
2	Nut, 3/8-16 Hex	F05010-1	2	
3	Washer, 3/8" Split Lock	F05011-4	3	
4	Terminal, 3/8 1-2 Ga Ring NI Loose	F05092-28	1	
5	Bolt, 3/8-16 x 1 1/4" Hex Head	F05007-2	1	
6	Washer, 3/8" SAE Flat	F05011-3	5	
7	Bracket, Battery Hold-Down	017725	1	
8	Nut, 3/8-16 Hex Lock	F05010-25	1	
9	Bolt, 3/8-16 x 4" Hex Head	F05007-4	2	
10	Washer, 3/8" External Star Lock	F05011-36	2	
11	Nut, 3/8" Hex Nylon Lock	F05010-10	2	
12	Washer, 1/4" SAE Flat	F05011-11	2	
13	Nut, 1/4-20 Wing	F05010-13	2	
14	Box Weldment, Battery	015191	1	
15	Fuse Box Parts (See Section 5.11)			
16	Grommet, 5/8" Rubber Wire	P11764	4	
17	LID WELDMENT, BATTERY BOX	033976	1	
18	DECAL, BATTERY BOX LID CAUTION	014774	1	
19	CABLE ASSEMBLY, 1 GA X 12" 150A FUSE TO BATTERY POSITIVE	036308	1	

Control & Battery Boxes
Battery Box Assembly (DC Only)

5

20	CABLE ASSEMBLY, 1 GA X 16" 225A FUSE TO BATTERY POSITIVE	036309	1	
21	CABLE ASSEMBLY, 1 GA X 26" BATTERY NEGATIVE TO NEG. CONTACT	036306	1	

5.10 Battery Box Assembly (DC Only)

LT60HD/70HD

Rev. A3.01 - B2.00

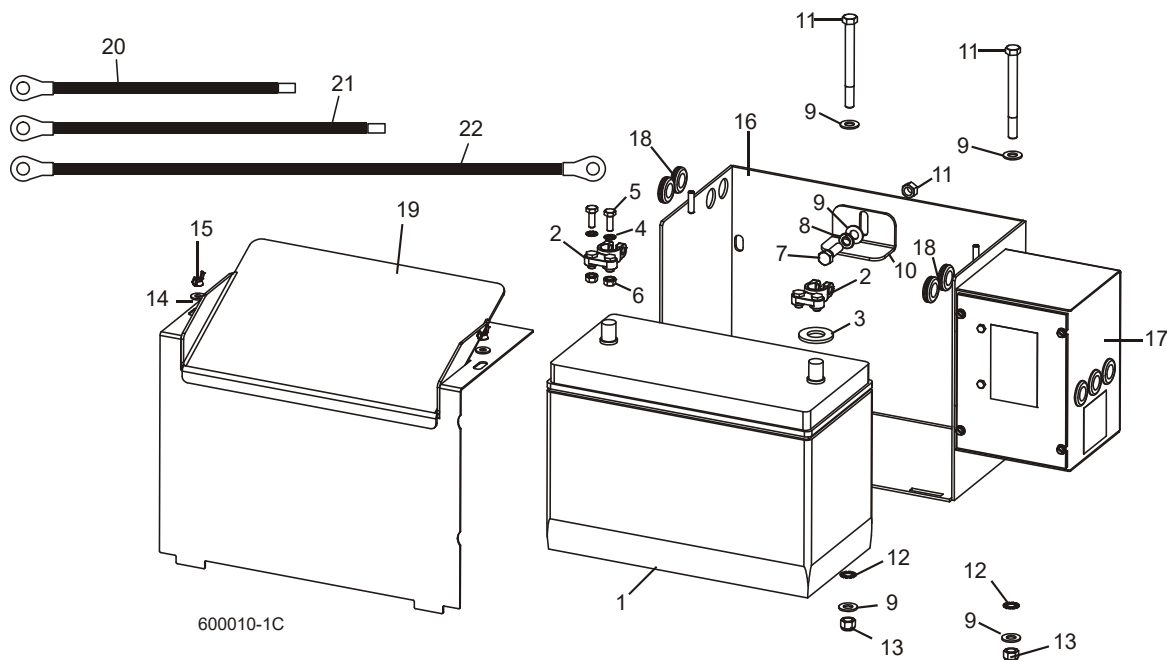

REF	DESCRIPTION (◆ Indicates Parts Available In Assemblies Only)	PART #	QTY.	
1	BATTERY, 12 VOLT ¹	015475	1	◆
	BOX ASSEMBLY, LT60/70 BATTERY	017674 ²	1	
2	Terminal, Battery	P05085	2	
3	Washer, Battery Terminal	P12161	1	
4	Washer, 1/4" Exterior Star Lock	F05011-37	2	
5	Bolt, 1/4-20 x 3/4" Hex Head Full Thread	F05005-1	2	
6	Nut, 1/4-20 Self-Locking Hex	F05010-9	2	
7	Bolt, 3/8-16 x 1 1/4" Hex Head	F05007-2	1	
8	Washer, 3/8" Split Lock	F05011-4	1	
9	Washer, 3/8" SAE Flat	F05011-3	5	
10	Bracket, Battery Hold-Down	017725	1	
11	Nut, 3/8-16 Hex Lock	F05010-25	1	
12	Washer, 3/8" External Star Lock	F05011-36	2	
13	Nut, 3/8" Hex Nylon Lock	F05010-10	2	
14	Washer, 1/4" SAE Flat	F05011-11	2	
15	Nut, 1/4-20 Wing	F05010-13	2	
16	Box Weldment, Battery	015191	1	
17	Fuse Box Parts (See Section 5.11)			
18	Grommet, 5/8" Rubber Wire	P11764	4	
19	LID WELDMENT, BATTERY BOX	033976	1	

Control & Battery Boxes

Battery Box Assembly (DC Only)

5

20	CABLE ASSEMBLY, 1 GA X 12" 150A FUSE TO BATTERY POSITIVE	036308	1	
21	CABLE ASSEMBLY, 1 GA X 16" 225A FUSE TO BATTERY POSITIVE	036309	1	
22	CABLE ASSEMBLY, 1 GA X 26" BATTERY NEGATIVE TO NEG. CONTACT	036306 ³	1	

¹ Battery changed from Deka 1231PMF to Trojan C31-1000 Rev. A5.02. Battery changed back to Deka 1131XPMF due to discontinuation of Trojan battery.

² Battery Box Assembly 017674 modified to include new fuse block and mega fuse Rev. B3.00 ([See Section 5.11](#)).

³ Replaces 024676 originally supplied (duplicate parts).

5 Control & Battery Boxes

Fuse Box Assembly (DC Only)

5.11 Fuse Box Assembly (DC Only)

LT60HD/70HD

Rev. B3.00 - B3.01

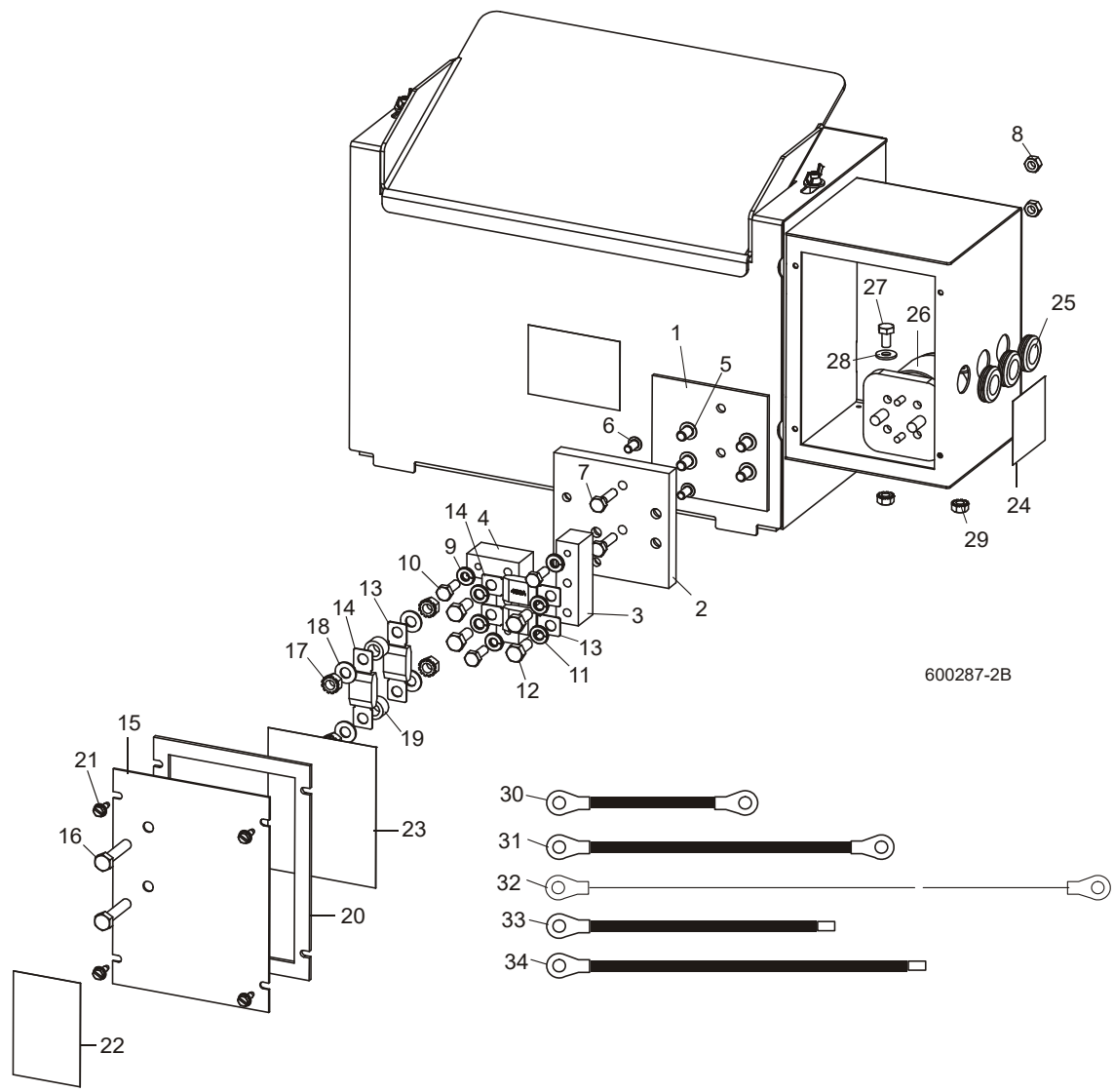

REF	DESCRIPTION (◆ Indicates Parts Available In Assemblies Only)	PART #	QTY.	
	BLOCK ASSEMBLY, DOUBLE FUSE	006795	1	
1	Plate, Fuse Block Insulator	056999	1	
2	Block, Fuse Mount	056997	1	◆
3	Block, 3/4" Upper Fuse	056996	1	
4	Block, 3/4" Lower Fuse	056998	2	
5	Screw, 5/16-18 x 1/2" Socket Button Head	F05006-20	4	
6	Screw, 1/4-20 x 1/2" Socket Button Head	F05005-59	2	
7	Bolt, 1/4-20 x 1" Hex Head Grade 5	F05005-101	2	
8	Nut, 1/4-20 Hex Lock	F05010-21	2	

Control & Battery Boxes

Fuse Box Assembly (DC Only)

5

9	Washer, 1/4" Split Lock	F05011-14	3	
10	Bolt, 1/4-20 x 3/4" Hex Head Grade 5	F05005-123	3	
11	Washer, 5/16" Split Lock	F05011-13	4	
12	Bolt, 5/16-18 x 3/4" Hex Head Grade 5	F05006-102	4	
13	FUSE, 225A 32V MEGA	053339	2	
14	FUSE, 450A 32V MEGA	053340	2	
	COVER ASSEMBLY, DOUBLE FUSE BOX	006853	1	
15	Cover, Fuse Box	006851	1	
16	Bolt, 5/16-18 x 1 1/2" Hex Head Full Thread	F05006-2	2	
17	Nut, 5/16-18 Hex Self-Locking	F05010-20	4	
18	Washer, 5/16" SAE Flat	F05011-17	4	
19	Spacer, .39" x .625" x .39"	055323	2	
20	Gasket, Fuse Box Cover	050283	1	
21	SCREW, #10-24 X 1/2" SELF-TAPPING	F05015-7	4	
22	DECAL, 12 VOLT WARNING	P10364	1	
23	DECAL, 225/450A MEGA FUSE ID	006868	1	
24	DECAL, HYDRAULIC CONTACT CAUTION	P12960	1	
25	GROMMET, 5/8" RUBBER WIRE	P11764	3	
26	SOLENOID KIT, 200A 12V SPST CONT. DUTY	016371	1	
	Solenoid, 200A 12V SPST Cont. Duty	015470	1	◆
	Diode Assembly, Solenoid Coil Chassis Gnd	015426	1	
	WIRE ASSEMBLY, HYDRAULIC SOLENOID VOLTAGE DROP	024451	1	
27	BOLT, 1/4-20 X 1/2" HEX HEAD	F05005-15	2	
28	WASHER, 1/4" SAE FLAT	F05011-11	2	
29	NUT, 1/4-20 SELF-LOCKING HEX	F05010-9	4	
30	CABLE ASSEMBLY, 1 GA X 6 1/2" FUSE TO SOLENOID	036305	1	
31	CABLE ASSEMBLY, 1 GA X 14" SOLENOID TO POSITIVE CONTACT	036307	1	
32	CABLE ASSEMBLY, 1 GA X 26" BATT. NEGATIVE TO GROUND CONTACT	036306	1	
33	CABLE ASSEMBLY, 1 GA X 12" 150A FUSE TO BATTERY POSITIVE	036308	1	
34	CABLE ASSEMBLY, 1 GA X 16" 225A FUSE TO BATTERY POSITIVE	036309	1	

5.12 Fuse Box Assembly (DC Only)

LT60HD/70HD

Rev. A3.01 - B2.00

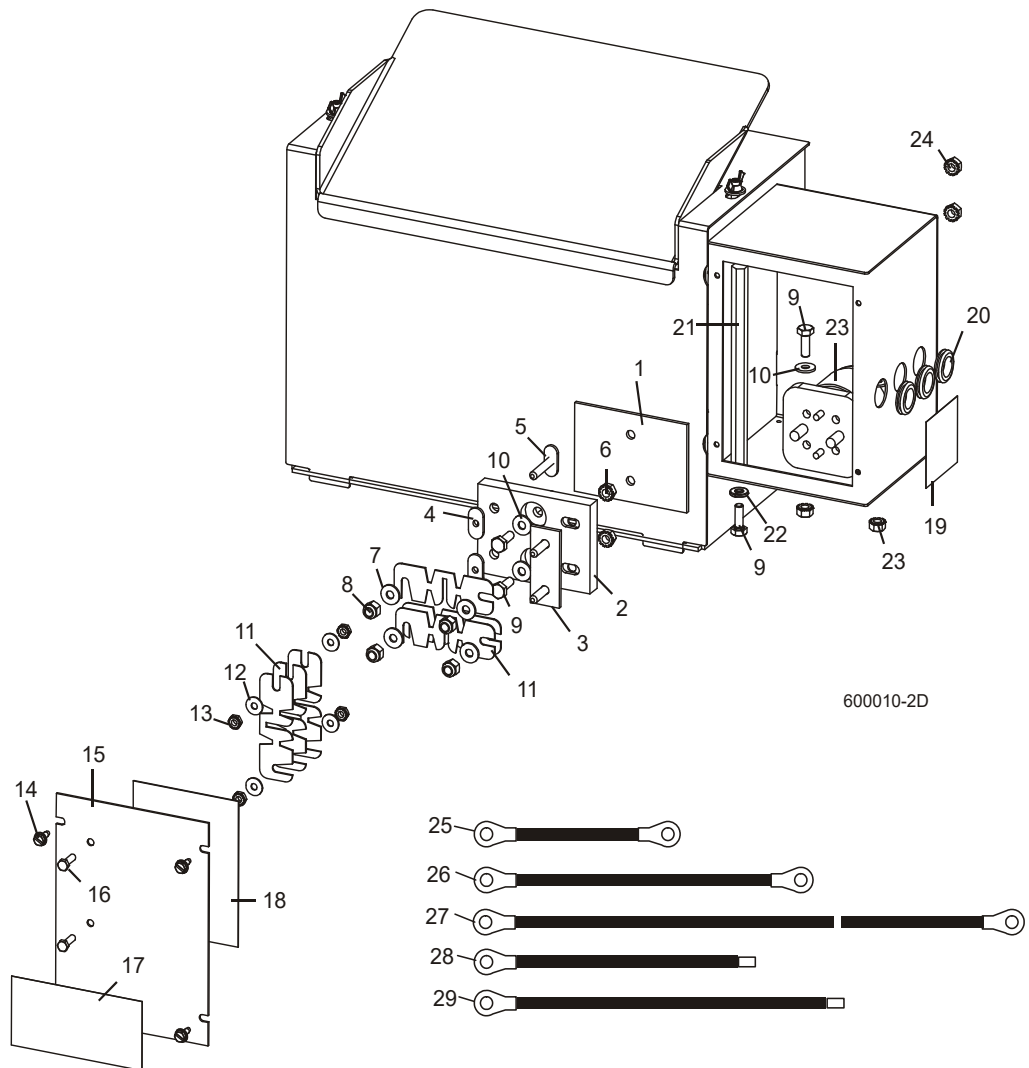

REF	DESCRIPTION (◆ Indicates Parts Available In Assemblies Only)	PART #	QTY.	
1	PAD, FUSE BOX INSULATOR	015287	1	
	FUSE BLOCK ASSEMBLY	017665 ¹	1	
2	Block, Fuse Mount	017664	1	◆
3	Post Weldment, Fuse Mount	017663	1	
4	Nut, 1/4-20 Cadmium Plated Weld	S12392	2	
5	Stud Weldment, 1/4-20 Fuse	W12389	2	
6	Nut, 1/4-20 Self-Locking Hex	F05010-9	2	
7	Washer, 1/4" SAE Flat	F05011-11	4	
8	Nut, 1/4-20 Hex Lock	F05010-21 ²	4	

9	BOLT, 1/4-20 X 3/4" HEX HEAD FULL THREAD	F05005-1	5	
10	WASHER, 1/4" SAE FLAT	F05011-11	4	
11	FUSE LINK, 12 VOLT 225 AMP	P11550	6	
12	WASHER, #10 SAE FLAT	F05011-18	4	
13	NUT, #10-24 HEX SELF-LOCKING	F05010-14	4	
14	SCREW, #10-24 X 1/2" SELF-TAPPING	F05015-7	4	
15	COVER, FUSE BOX	015282	1	
16	SCREW, #10-24 X 5/8" HEX HEAD	F05004-18	2	
17	DECAL, 12 VOLT WARNING	P10364	1	
18	DECAL, FUSE LINK I.D. LT60/70	017681	1	
19	DECAL, HYDRAULIC CONTACT CAUTION	P12960	1	
20	GROMMET, 5/8" RUBBER WIRE	P11764	3	
21	TERMINAL, EXTENDED HEX STUD	015517	1	
22	WASHER, 1/4" SPLIT LOCK	F05011-14	1	
23	SOLENOID KIT, 200A 12V SPST CONT. DUTY	016371	1	
	Solenoid, 200A 12V SPST Cont. Duty	015470	1	◆
	Diode Assembly, Solenoid Coil Chassis Gnd	015426 ³	1	
	WIRE ASSEMBLY, HYDRAULIC SOLENOID VOLTAGE DROP	024451	1	
24	NUT, 1/4-20 SELF-LOCKING HEX	F05010-9	4	
25	CABLE ASSEMBLY, 1 GA X 6 1/2" FUSE TO SOLENOID	036305	1	
26	CABLE ASSEMBLY, 1 GA X 14" SOLENOID TO POSITIVE CONTACT	036307	1	
27	CABLE ASSEMBLY, 1 GA X 26" BATT. NEGATIVE TO GROUND CONTACT	036306	1	
28	CABLE ASSEMBLY, 1 GA X 12" 150A FUSE TO BATTERY POSITIVE	036308	1	
29	CABLE ASSEMBLY, 1 GA X 16" 225A FUSE TO BATTERY POSITIVE	036309	1	

¹ Battery Box Assembly modified to include new fuse block and mega fuse Rev. B3.00 ([See Section 5.11](#)). Use kit 006906 to retrofit (requires one 225A Mega-Fuse 053339 and one 450A Mega-Fuse 053340 sold separately).

² Swaged lock nut F05010-21 replaces Nylon Lock Nut F05010-69 originally supplied prior to 7/08. Heat from the fuses can cause the nylon to melt and the nut to come loose. Nuts and washers added to fuse block kit 017665 11/08.

³ Diode Assembly 015426 added to prevent damage to hydraulic microswitch (Rev. A3.03).

SECTION 6 UP/DOWN SYSTEM

6.1 Up/Down Rollers & Covers

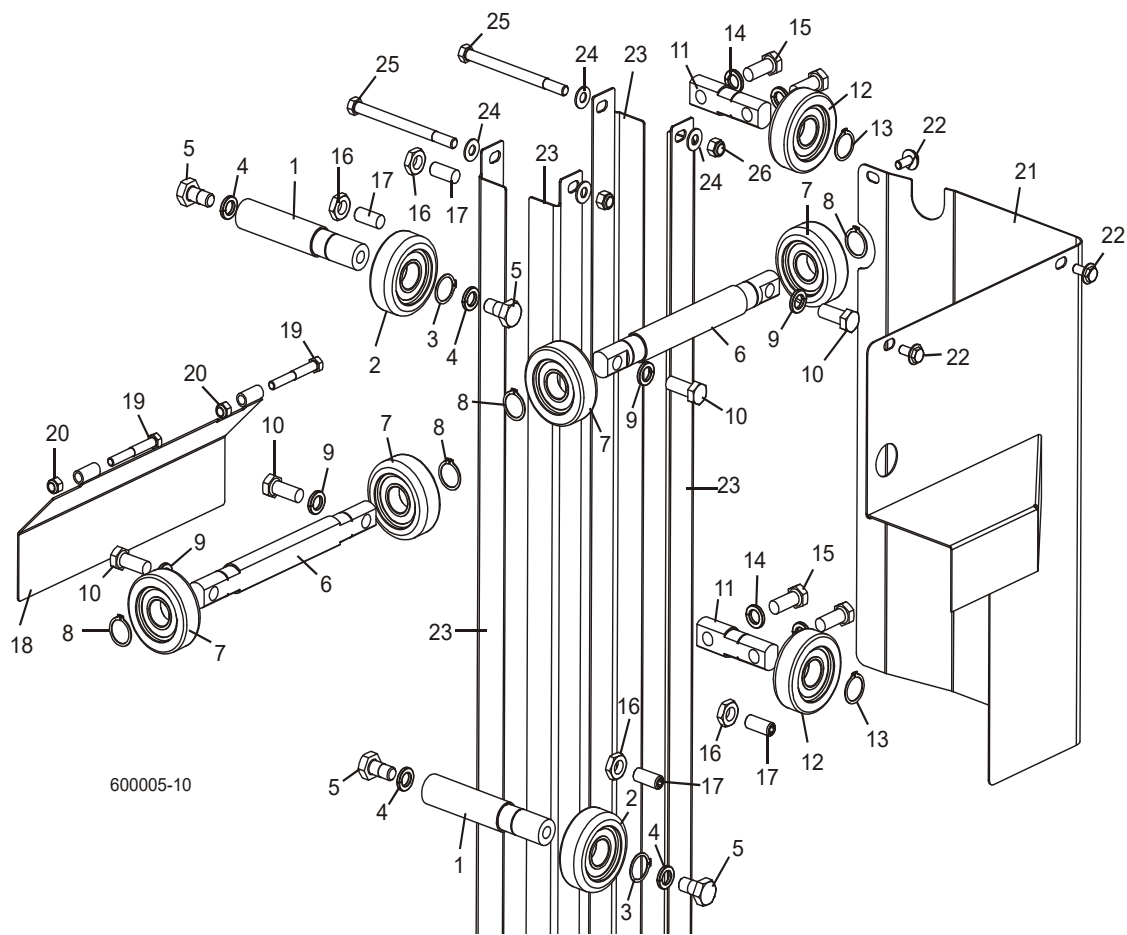

REF	DESCRIPTION (◆ Indicates Parts Available In Assemblies Only)	PART #	QTY.
	ROLLER ASSEMBLY, INSIDE UP/DOWN	034339	2
1	Shaft, Inside Up/Down Roller	033855	1
2	Bearing, MG305DDA	023857	1
3	Ring, 1" Outside Retaining	F04254-15	1
4	Washer, 1/2" Split Lock	F05011-9	2
5	Bolt, 1/2-13 x 1" Hex Head Grade 2	F05008-50	2
	ROLLER ASSEMBLY, LONG UP/DOWN	034337	2
6	Shaft, Long Up/Down Roller	033853	1
7	Bearing, MG305DDA	023857	2
8	Ring, 1" Outside Retaining	F04254-15	2
9	Washer, 1/2" Split Lock	F05011-9	2

10	Bolt, 1/2-13 x 1 1/4" Hex Head Grade 5	F05008-37	2	
	ROLLER ASSEMBLY, SHORT UP/DOWN	034338	2	
11	Shaft, Short Up/Down Roller	033854	1	
12	Bearing, MG305DDA	023857	1	
13	Ring, 1" Outside Retaining	F04254-15	1	
14	Washer, 1/2" Split Lock	F05011-9	2	
15	Bolt, 1/2-13 x 1 1/2" Hex Head Grade 5	F05008-33	2	
16	NUT, 1/2-13 HEX JAM	F05010-31	4	
17	SCREW, 1/2-13 X 1 1/4" BRASS TIP SET	F05008-18	4	
18	COVER WELDMENT, LOWER UP/DOWN ROLLER	034277	1	
19	BOLT, 5/16-18 X 2 1/2" HEX HEAD GRADE 5	F05006-80	2	
20	NUT, 5/16-18 NYLON LOCK	F05010-58	2	
21	COVER WELDMENT, UP/DOWN DRIVE (D42)	036182	1	
	COVER WELDMENT, UP/DOWN DRIVE (E25)	036184	1	
22	BOLT, 5/16-18 X 3/4" HEX WASHER HEAD	F05006-101	4	
23	ANGLE, MAST TUBE STAINLESS	033827	4	
24	WASHER, 3/8" SAE FLAT	F05011-3	8	
25	BOLT, 3/8-16 X 5" HEX HEAD	F05007-5	4	
26	NUT, 3/8-16 NYLON LOCK	F05010-10	4	

6.2 Blade Height & Quarter Scales

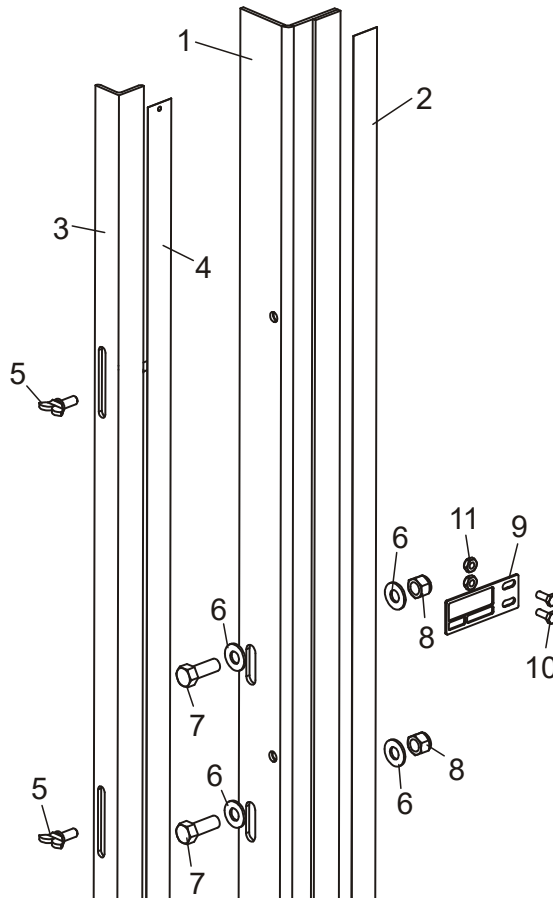

600123-2

REF	DESCRIPTION (◆ Indicates Parts Available In Assemblies Only)	PART #	QTY.
	SCALE ASSEMBLY, LT60/70	034372	1
1	Angle Weldment, Scale Mount	034370	1
2	Decal, Movable Inch Scale	S11773	1
	Scale Assembly, LT60/70 Quarter	034371	1
3	Angle, Quarter Scale Mount	034369	1
4	Decal, Movable Grade Quarter Scale	P12819 ¹	1
5	Screw, 1/4-20 x 5/8" Wing	F05005-64	2
6	Washer, 3/8" SAE Flat	F05011-3	4
7	Bolt, 3/8-16 x 1" Hex Head	F05007-7	2
8	Nut, 3/8-16 Hex Nylon Lock	F05010-10	2
9	INDICATOR, BLADE HEIGHT	017778	1
10	SCREW, #10-24 X 1/2" HEX HEAD STAINLESS STEEL	F05004-27	2
11	NUT, #10-24 SELF-LOCKING HEX	F05010-160	2

¹ Grade Quarter Scale Decal P12819 provided with sawmill. Standard Quarter Scale Decal S11774 available separately. Order Angle Mount 034369 and Standard Quarter Scale Decal S11774.

6.3 Up/Down Chain & Sprockets

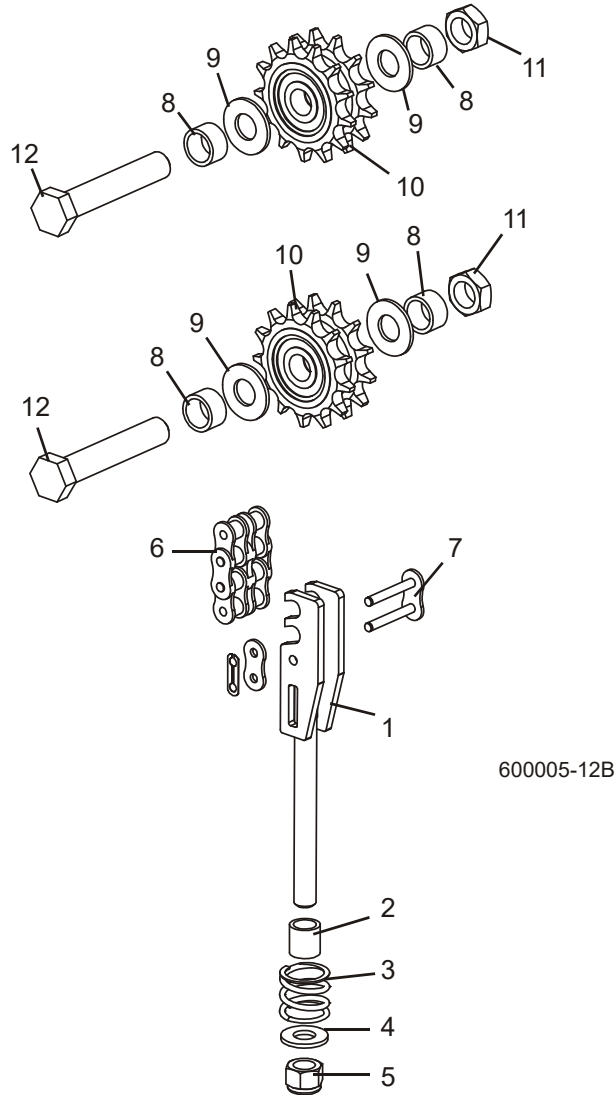

REF	DESCRIPTION (◆ Indicates Parts Available In Assemblies Only)	PART #	QTY.
	TENSIONER ASSEMBLY, LT60/70 UP/DOWN CHAIN	034238	1
1	Tensioner Weldment, Up/Down Chain	034236	1
2	Spacer, Up/Down Chain Tensioner	016515	1
3	Spring, 1" OD x 1" Long x .125 Wire Compression	016516	1
4	Washer, 1/2" SAE Flat	F05011-2	1
5	Nut, 1/2-13 Nylon Lock	F05010-8	1
6	CHAIN, LT60/70 UP/DOWN #50-2 X 73 1/8"	036197	1
7	LINK, #50-2 MASTER	015258	2

6**Up/Down System***Up/Down Chain & Sprockets*

8	SPACER, #50-2 IDLER	016018	4	
9	WASHER, 5/8" SAE FLAT	F05011-5	4	
10	SPROCKET ASSEMBLY, #50-2 UP/DOWN IDLER	016019	2	
11	NUT, 5/8-11 HEX NYLON LOCK JAM	F05010-96	2	
12	BOLT, 5/8-11 X 3 1/2" HEX HEAD GRADE 5	F05009-93	2	

6.4 Up/Down Drive Assembly

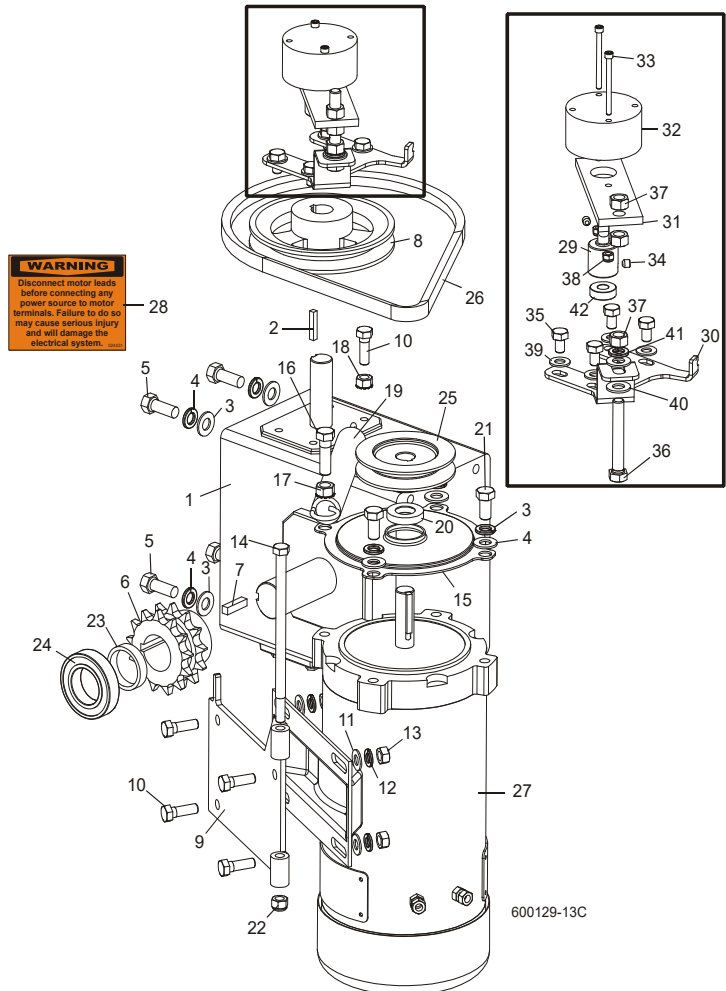

WARNING
Disconnect motor leads before connecting any power source to motor terminals. Failure to do so may cause serious injury and will damage the electrical system.

REF	DESCRIPTION (◆ Indicates Parts Available In Assemblies Only)	PART #	QTY.	
1	GEAR BOX, B226-60-2-1L	034908	1	
2	KEY, 3/16" SQUARE X 1" LONG	S31027	1	
3	WASHER, 3/8" SAE FLAT	F05011-3	7	
4	WASHER, 3/8" SPLIT LOCK	F05011-4	7	
5	BOLT, 3/8-16 X 1" HEX HEAD	F05007-7	4	
6	SPROCKET, DOUBLE 50-13 X 1 1/4"	036008	1	
7	KEY, 1/4" SQUARE X 1" LONG	S21486	1	
8	PULLEY, AK51 X 3/4" BORE	015256	1	
9	BRACKET WELDMENT, UP/DOWN MOTOR MOUNT	015198	1	
10	BOLT, 5/16-18 X 1" HEX HEAD	F05006-1	5	
11	WASHER, 5/16" SAE FLAT	F05011-17	4	
12	WASHER, 5/16" SPLIT LOCK	F05011-13	4	
13	NUT, 5/16-18 HEX	F05010-17	4	

14	BOLT, 5/16-18 X 6" HEX HEAD GRADE 5	F05006-73	1	
15	COVER, UP/DOWN MOTOR	034475	1	
16	BOLT, 3/8-16 X 1 1/4" HEX HEAD GRADE 5	F05007-123	1	
17	NUT, 3/8-16 HEX SELF-LOCKING	F05010-19	1	
18	NUT, 5/16-18 HEX SELF-LOCKING	F05010-20	1	
19	SPRING, 1" OD X 7" LONG X .148 WIRE EXTENSION	019303	1	
20	SEAL, CR6315	034501	1	
21	BOLT, 3/8-16 X 3/4" HEX HEAD	F05007-27	3	
22	NUT, 5/16-18 NYLON LOCK	F05010-58	1	
23	SPACER, UP/DOWN SPROCKET	036016	1	
24	BEARING, R20-2RS	036007	1	
25	PULLEY, AK20 X 5/8" BORE (DC WITHOUT UP/DOWN ASSIST AND ALL AC)	036179 ¹	1	
	PULLEY, AK34 X 5/8" BORE (DC WITH UP/DOWN ASSIST)	036675 ¹	1	
26	BELT, 4L300 (DC WITHOUT UP/DOWN ASSIST AND ALL AC)	021183 ¹	1	
	BELT, AX30 (DC WITH UP/DOWN ASSIST)	036682 ¹	1	
27	MOTOR, 3/4HP 12VDC (DC ONLY)	015174	1	
	Brush Kit, Power Feed Motor (Includes 2 Brushes and 2 Springs)	024167	1	
	Fan, 3/4 HP Leeson Motor Replacement	016087	1	
	Guard, Motor Fan	047998	1	
	Hub, Motor Fan Extension	047999	1	
	MOTOR, 1HP 230/460VAC 3P 1725RPM (AC ONLY)	050290	1	
28	DECAL, DISCONNECT MOTOR LEADS WARNING (DC ONLY)	024431	1	
	OIL, 8 OZ. MOBIL SHC634 BOTTLED SYNTHETIC GEAR	L04869-4 ²	1	
	BRAKE ASSEMBLY, LT70 UP/DOWN	065188 ³	1	
29	Shaft, Up/Down Brake	062511	1	
30	Plate, LT70 Up/Dn Brake Mount	062512	1	
31	Plate, Brake Mount	062513	1	
32	Brake, Up/Down	069519	1	
33	Bolt, #8-32 x 2" Socket Head Stainless Steel	F05004-273	2	
34	Screw, 1/4-20 x 1/4" Cup Point Socket Set	F05005-131	2	
35	Bolt, 5/16-18 x 1/2" Hex Head Grade 5	F05006-15	2	
36	Bolt, 3/8-16 x 2 1/2" Hex Head Full Thread	F05007-157	1	
37	Nut, 3/8-16 Hex	F05010-1	3	
38	Nut, #8-32 Hex Nylon Lock	F05010-169	2	
39	Washer, 5/16" SAE Flat	F05011-17	4	
40	Washer, 3/8" SAE Flat	F05011-3	2	
41	Washer, 3/8" Split Lock	F05011-4	1	
42	Bearing, R6-2NSL SRI-2 ABEC-1	P10688	1	

¹ Use 4L300 Belt 021183 and AK20 Pulley 036179 for DC sawmills prior to Rev. A5.00 without up/down assist and all AC sawmills. Use AX30 Belt 036682 and AK34 Pulley 036675 for DC sawmill Rev. A5.00 and later with up/down assist.

² 40 oz. required for complete oil replacement.

³ Brake added 2/11 to prevent saw head from drifting during sawing. Use retrofit kit 062566 to retrofit previous revisions.

6.5 Up/Down Assist Assembly

LT60HD/70HD

Rev. A5.00 - B3.01

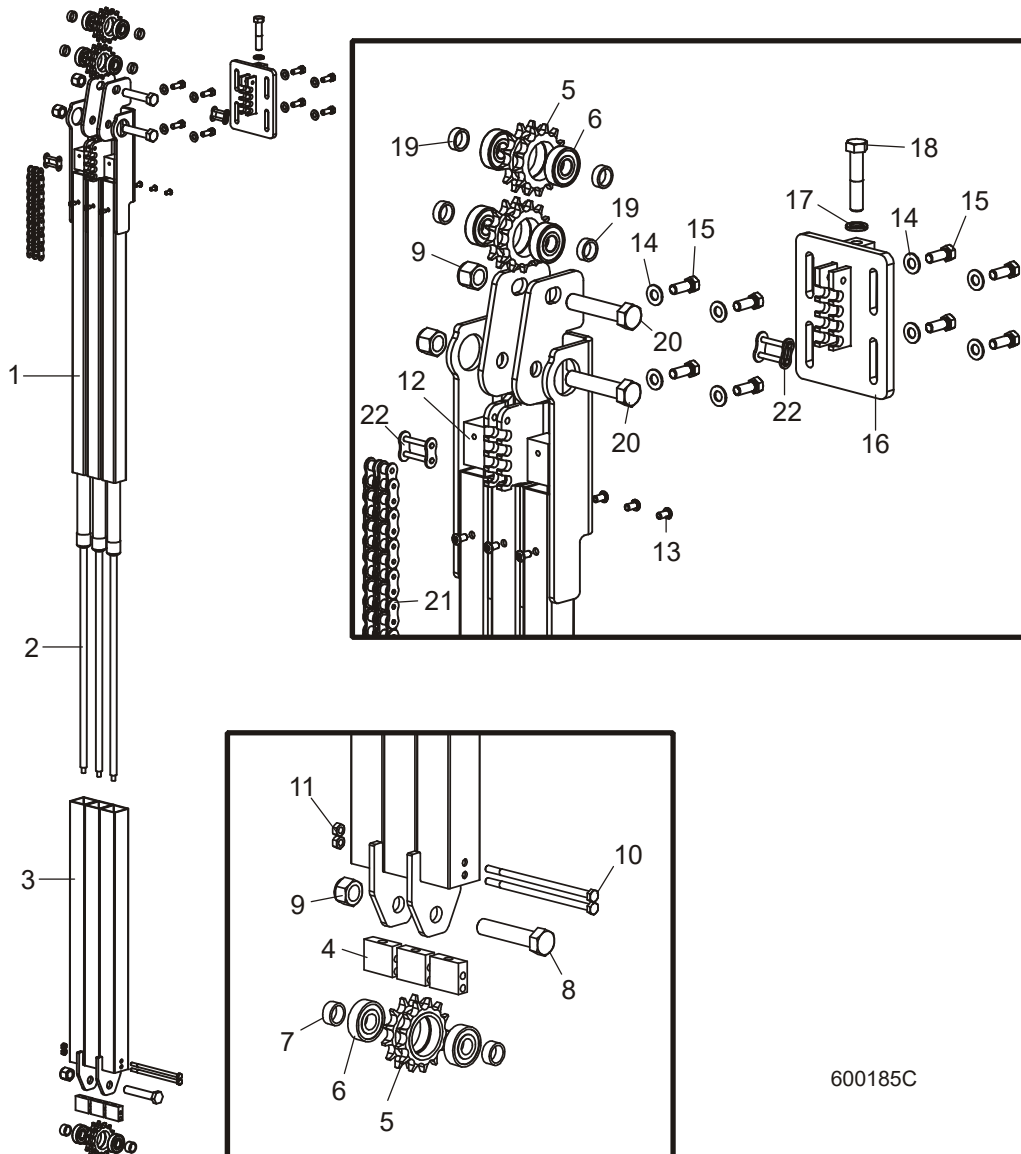

600185C

REF	DESCRIPTION (◆ Indicates Parts Available In Assemblies Only)	PART NUMBER	QTY.	
	ASSIST ASSEMBLY, LT70 UP/DOWN	047753	1	
1	Tube Weldment, Upper Assist	047754	1	
2	Spring Assembly, 562 Lb Gas w/Wiper	065410 ¹	3	
	Spring, Gas 562 Lb.	047737	1	◆
	Wiper, .542" Gas Spring Rubber	038628	1	
3	Tube Weldment, Lower Assist	047755	1	
4	Block, Lower Gas Spring Mount	048410	3	
	Sprocket Assembly, #50-2 Idler	016019	3	

6

Up/Down System*Up/Down Assist Assembly*

5	Sprocket, D50B13 Modified	015202	1	
6	Bearing, 5/8" ID x 1.7548" OD x .4724"	P06030-1	1	
7	Spacer, 50-2 Idler	016018	2	
8	Bolt, 5/8-11 x 3 1/2" Hex Head Grade 5	F05009-93	1	
9	Nut, 5/8-11 Hex Nylon Lock	F05010-34	3	
10	Bolt, 1/4-20 x 5 1/2" Hex Head Grade 5	F05005-82	2	
11	Nut, 1/4-20 Hex Lock	F05010-21	2	
12	Block, Upper Gas Spring Mount	047922	3	
13	Screw, 1/4-20 x 1/2" Button Socket Head	F05005-59	6	
14	Washer, 3/8" SAE Flat	F05011-3	8	
15	Bolt, 3/8-16 x 1" Hex Head Grade 5	F05007-87	8	
16	Mount Weldment, Up/Down Assist	047924	1	
17	Washer, 1/2" Split Lock	F05011-9	1	
18	Bolt, 1/2-13 x 2 1/2" Hex Head Grade 5	F05008-74	1	
19	Spacer, 50-2 Idler	047921	4	
20	Bolt, 5/8-11 x 3" Hex Head Grade 5	F05009-37	2	
21	Chain, #50-2 Up/Down Assist	036680	1	
22	Link, #50-2 Master	015258	2	
23	Wiper, .542" Gas Spring Rubber	038628 ²	3	

¹ 065410 Spring Assembly created to include 047737 Gas Spring and 038628 Gas Spring Rubber Wiper epoxyed together (6/11).

² Wipers added to assist assembly Rev. A7.07 to prevent sawdust buildup and improve spring durability. Wipers can be used to service previous gas springs.

SECTION 7 FEED SYSTEM & TRACK ROLLERS

7.1 Upper Track Rollers And Wipers

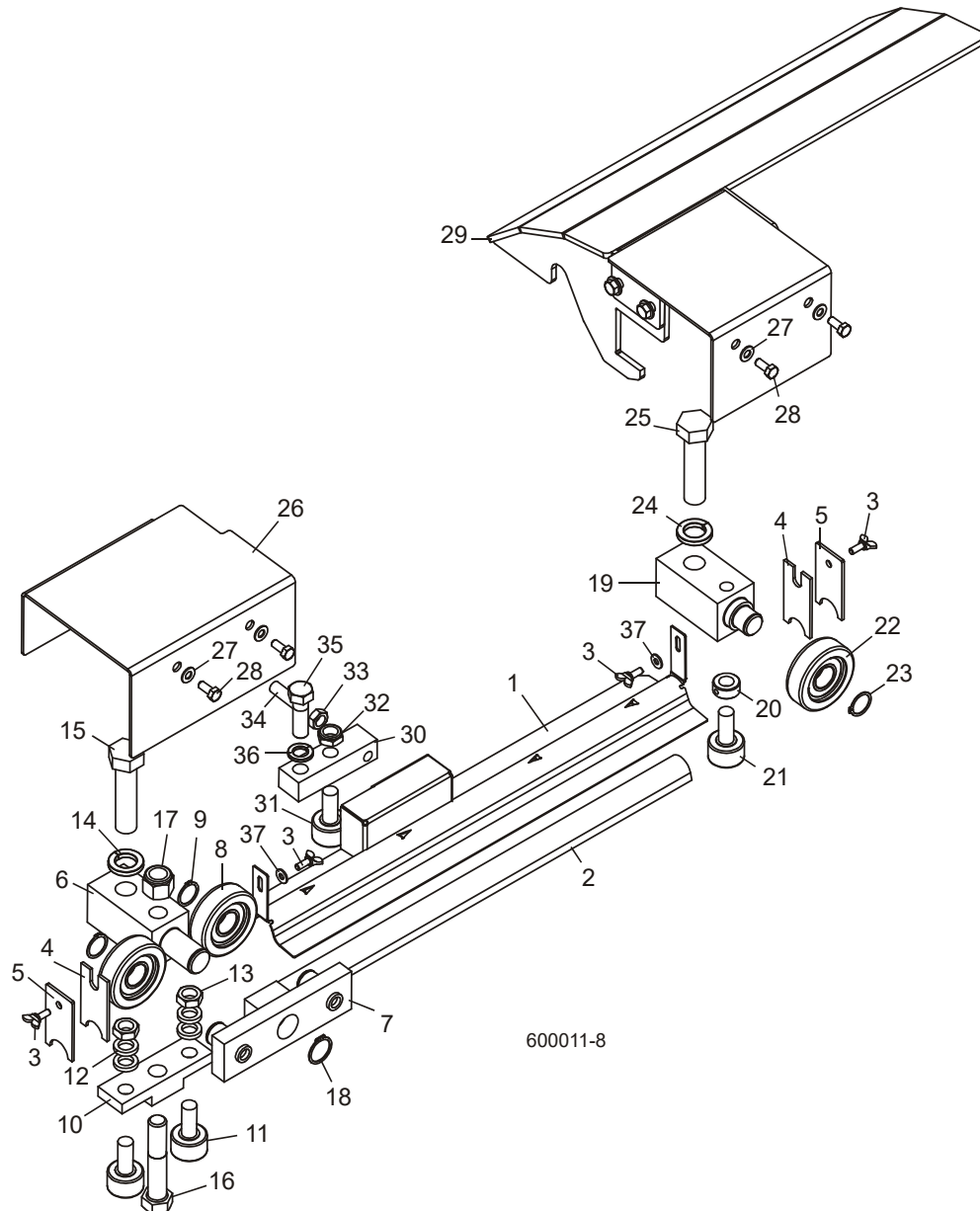

REF	DESCRIPTION (◆ Indicates Parts Available In Assemblies Only)	PART #	QTY.	
	WIPER ASSEMBLY, MIDDLE TRACK	017928	1	
1	Wiper Housing, Middle Track	017920	1	◆
2	Wiper, 3/16" x 2" x 23" Felt	S09915	1	
3	BOLT, 1/4-20 X 5/8" WING	F05005-64	4	

7

Feed System & Track Rollers

Upper Track Rollers And Wipers

4	WIPER, TOP RAIL	M04113	2	
5	PLATE, TRACK WIPER	034229	2	
	ROLLER ASSEMBLY, FRONT UPPER TRACK	042506	1	
6	Block, Upper Roller Mount	042505	1	
7	Block Assembly, Upper Roller	042507	1	
8	Bearing, MG305DDA	023857	2	
9	Ring, 1" Outer Retaining	F04254-15	2	
10	Block, Track Bearing Mount	042500	1	
11	Bearing, 1 1/2" Track	012797	2	
12	Spacer, 41/64" x 1" x 3/16"	S12480	4	
13	Nut, 5/8-18 Hex Jam	F05010-11	2	
14	Washer, 7/8" Split Lock	F05011-46	1	
15	Bolt, 7/8-14 x 3 1/2" Hex Head Grade 5	F05014-1	1	
16	Bolt, 3/4-10 x 4" Hex Head Grade 5	F05013-3	1	
17	Nut, 3/4-10 Hex Nylon Lock	F05010-103	1	
18	Ring, 1 1/8" Outer Retaining	F04254-36	1	
	ROLLER ASSEMBLY, REAR UPPER TRACK	034231	1	
19	Block, Upper Roller Mount	034230	1	
20	Collar, 5/8" ID Lock	P05035	1	
21	Bearing, 1 1/2" Track	012797	1	
22	Bearing, MG305DDA	023857	1	
23	Ring, 1" Outer Retaining	F04254-15	1	
24	Washer, 7/8" Split Lock	F05011-46	1	
25	Bolt, 7/8-14 x 3 1/2" Hex Head Grade 5	F05014-1	1	
26	COVER, FRONT UPPER TRACK ROLLER	033942	1	
27	WASHER, 5/16" SPLIT LOCK	F05011-17	4	
28	BOLT, 5/16-18 X 3/4" HEX HEAD	F05006-102	4	
29	POWER FEED MOTOR GUARD PARTS (See Section 7.2)¹			
30	BLOCK, MIDDLE UPPER TRACK ROLLER MOUNT	017884	1	
31	BEARING, 1 1/2" TRACK	012797	1	
32	NUT, 5/8-18 NYLON HEX JAM	F05010-101	1	
33	NUT, 1/2-20 HEX JAM	F05010-16	1	
34	SCREW, 1/2-20 X 1 3/4" FLAT POINT SET	F05008-112	1	
35	BOLT, 5/8-11 X 2" HEX HEAD	F05009-2	1	
36	WASHER, 5/8" SPLIT LOCK GRADE 8	F05011-118 ²	1	

¹ Optional extended guard assembly now standard with Rev. A7.10 (replaces 033939 previously supplied).

² Grade 8 washer replaces F05011-27 originally supplied before 8/07 to improve durability.

7.2 Power Feed Assembly

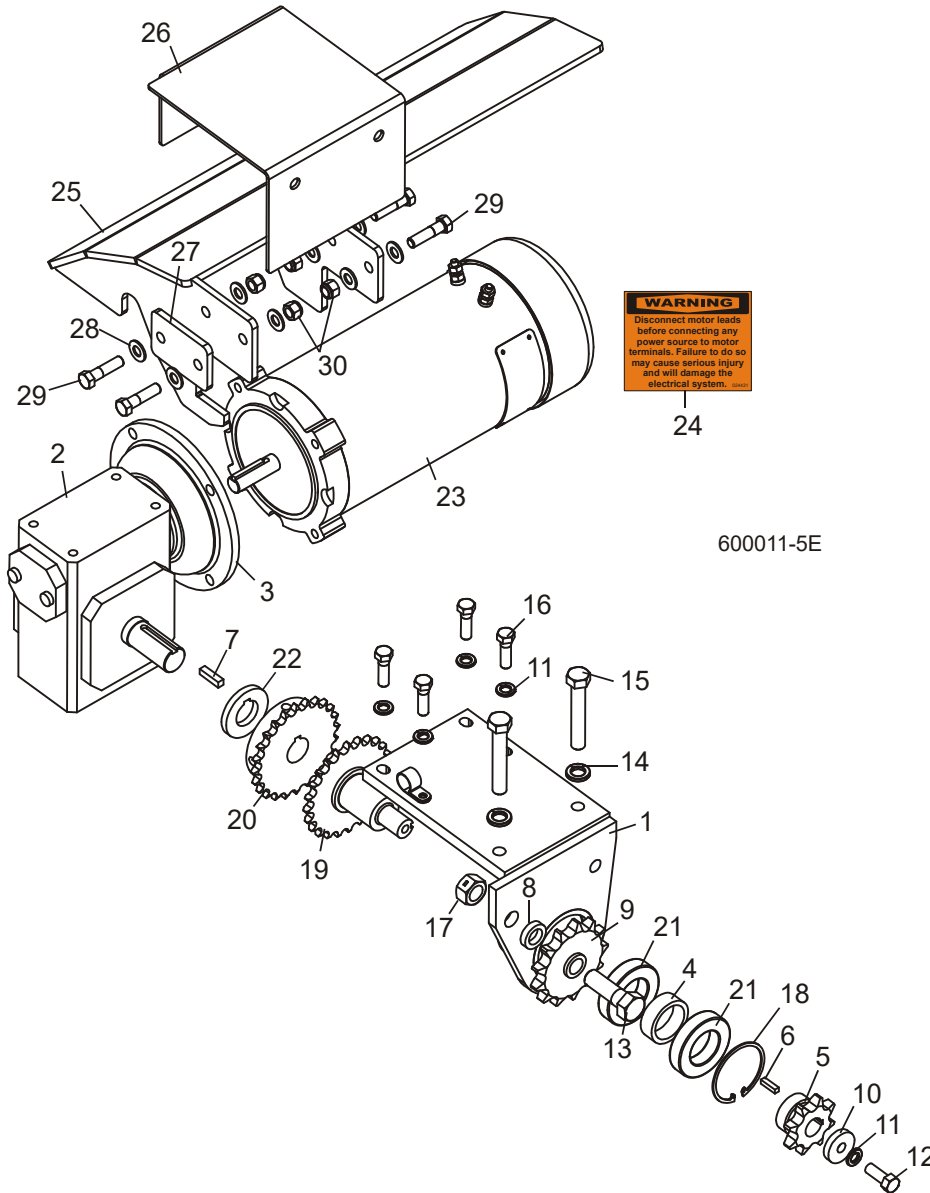

REF	DESCRIPTION (◆ Indicates Parts Available In Assemblies Only)	PART #	QTY.
	POWER FEED ASSEMBLY	034860	1
1	Bracket Weldment, Power Feed Mount	034850	1
2	Gearbox, Power Feed	034843	1
3	Plate, Gearbox Adaptor	057444	1
4	Spacer, 1.185 x 1.5 x .428	034856	1
5	Sprocket, 60B8 x 3/4" Modified	017723	1
6	Key, 3/16" Square x 3/4" Long	S03060	2

7

Feed System & Track Rollers

Power Feed Assembly

7	Key, 1/4" Square x 1" Long	S21486	1	
8	Spacer, .63 x 1.00 x .226	017719	1	
9	Sprocket, 60BB13H x 5/8" Idler	034224	1	
10	Washer, 3/8" ID x 1 1/4" OD	S02779	1	
11	Washer, 3/8" Split Lock	F05011-4	5	
12	Bolt, 3/8-16 x 1" Hex Head	F05007-7	1	
13	Bolt, 5/8-11 x 2" Hex Head Gr2	F05009-2	1	
14	Washer, 1/2" Split Lock	F05011-9	2	
15	Bolt, 1/2-20 x 3" Hex Head Full Thread	F05008-62	2	
16	Bolt, 3/8-16 x 1 1/4" Hex Head Full Thread Grade 5	F05007-123	4	
17	Nut, 5/8-11 Swaged Hex	F05010-4	1	
18	Ring, 62mm IR	F04254-12	1	
19	Shaft Weldment, LT60/70 Power Feed	034855	1	
20	Sprocket, 40B24 x1	034851	1	
21	Bearing, 6007-2RS 35x62x14	034852	2	
22	Spacer, 1.03" ID x 2" OD x 3/8" Keyed	034857	1	
	Chain, Double #40 x 11 1/2"	036196	1	
	Link, #40 x 2 Connecting	017724	1	
	Oil, 8 Oz. Mobil SHC634 Bottled Synthetic Gear	L04869-4 ¹	1	
23	MOTOR, 1HP 12VDC POWER FEED (DC ONLY)	053679 ²	1	
	Guard, Motor Fan	047998	1	
	Hub, Motor Fan Extension	047999	1	
	Key, 3/16" Square x 1" Long	S31027	1	
	Brush Kit, 3/4HP 12V DC Leeson Motor	024167	1	
	MOTOR, 1.5HP 230/460VAC 3P 1725RPM POWER FEED (AC ONLY)	050291	1	
24	DECAL, DISCONNECT MOTOR LEADS WARNING (DC ONLY)	024431	1	
	GUARD ASSEMBLY, LT70 FEED MOTOR (OPTIONAL)	038878-A ³	1	
25	Guard Weldment, LT70 Feed Motor	038877	1	
26	Guard, Top Track Roller	038876	1	
27	Plate, LT70 Power Feed Guard Spacer	038874	1	
28	Washer, 3/8" SAE Flat	F05011-3	8	
29	Bolt, 3/8-16 x 1 1/2" Hex Head Grade 5	F05007-78	4	
30	Nut, 3/8-16 Hex Nylon Lock	F05010-10	4	

¹ 12 - 15 oz. required for complete oil replacement.

² Replaces 3/4HP 12VDC Power Feed Motor 024169 (Rev. B4.11). Power Feed Motor 024169 included Brush Kit 024167, Fan 016087, Fan Guard 047998, Fan Extension Hub 047999 and 3/16" Square x 1" Long Key S31027.

³ Optional feed motor guard available 12/06 to protect motor & gearbox from falling logs. Mounting holes pre-drilled on Rev. A7.08 and later. Drilling of mounting holes required for previous revisions. Guard supplied as standard equipment Rev. A7.10.

7.3 Feed Chain/Stop

LT60HD/70HD

Rev. B1.00 - B1.03

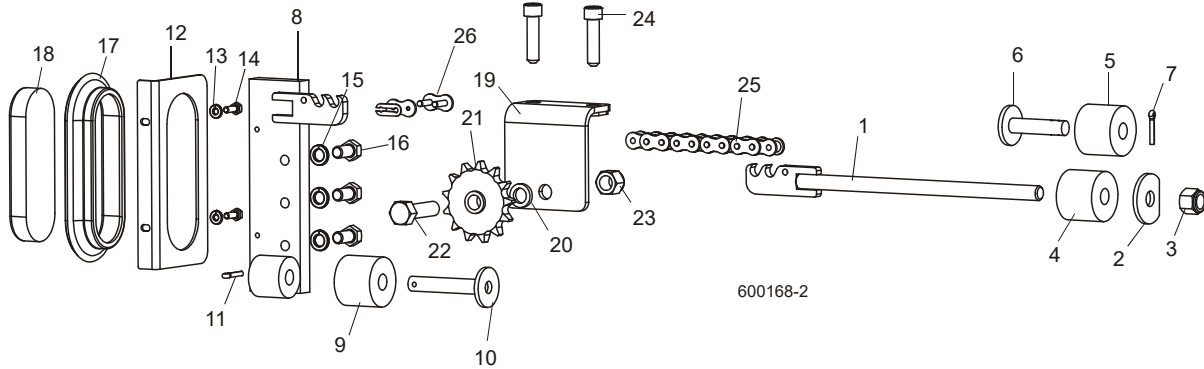

REF	DESCRIPTION (◆ Indicates Parts Available In Assemblies Only)	PART #	QTY.
	STOP ASSEMBLY, FRONT POWER FEED	034556	1
1	Tensioner Weldment, Power Feed Chain	034421	1
2	Washer, 21/32" x 2 1/4" x 3/16" D	017838	1
3	Nut, 5/8-11 Nylon Lock	F05010-34	1
4	Stop, Rubber Carriage	P12165	1
	Stop Kit, Rubber Carriage	K09630	1
5	Stop, Rubber Carriage	P12165	1
6	Pin, Rubber Carriage Stop	W09293	1
7	Pin, 3/16" X 1" Cotter	F05012-21	1
	STOP ASSEMBLY, REAR POWER FEED W/LIGHT	006721	1
8	Stop Weldment, Rear Power Feed	036493	1
9	Stop, Rubber Carriage	P12165	1
10	Pin, Rear Carriage Stop	034423	1
11	Pin, 3/16" X 1" Cotter	F05012-21	1
12	Plate, Bed Tube End	057822	1
13	Washer, 1/4" Split Lock	F05011-14	2
14	Bolt, 1/4-20 x 3/4" Hex Head	F05005-1	2
15	Washer, 1/2" Split Lock	F05011-9	3
16	Bolt, 1/2-13 x 1" Hex Head Grade 8	F05008-128	3
17	Grommet, 6 1/2" Light Mounting	006688	1
18	Light, 8 Diode LED Tail	006391	1
	IDLER ASSEMBLY, #60 POWER FEED CHAIN	034228	1
19	Plate Weldment, Power Feed Idler	034227	1
20	Spacer, 41/64" x 1" x 3/16"	S12480	1
21	Sprocket, 60BB13H x 5/8" Idler	034224	1
22	Bolt, 5/8-18 x 2 1/4" Hex Head Grade 5	F05009-80	1
23	Nut, 5/8-18 Nylon Lock	F05010-71	1
24	Bolt, 1/2-13 x 2" Socket Head	F05008-133	2

7 Power Feed System

Feed Chain/Stop

25	CHAIN, #60 X 285" POWER FEED	003319	1	
26	LINK, #60 MASTER	042398	2	

7.4 Feed Chain/Stop

LT60HD/70HD

Rev. A3.03 - A9.00

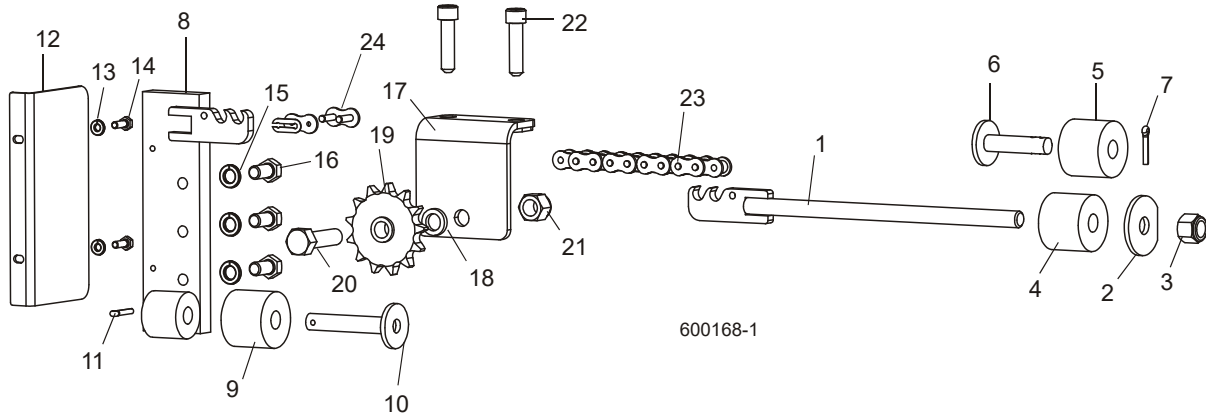

REF	DESCRIPTION (◆ Indicates Parts Available In Assemblies Only)	PART #	QTY.
	STOP ASSEMBLY, FRONT POWER FEED	034556	1
1	Tensioner Weldment, Power Feed Chain	034421	1
2	Washer, 21/32" x 2 1/4" x 3/16" D	017838	1
3	Nut, 5/8-11 Nylon Lock	F05010-34	1
4	Stop, Rubber Carriage	P12165	1
	Stop Kit, Rubber Carriage	K09630	1
5	Stop, Rubber Carriage	P12165	1
6	Pin, Rubber Carriage Stop	W09293	1
7	Pin, 3/16" X 1" Cotter	F05012-21	1
	STOP ASSEMBLY, REAR POWER FEED	034557 ¹	1
8	Stop Weldment, Rear Power Feed	036493 ¹	1
9	Stop, Rubber Carriage	P12165	1
10	Pin, Rear Carriage Stop	034423	1
11	Pin, 3/16" X 1" Cotter	F05012-21	1
12	Plate, Bed Tube End	036492 ¹	1
13	Washer, 5/16" Split Lock	F05011-13	2
14	Bolt, 5/16-18 x 3/4" Hex Head	F05006-5	2
15	Washer, 1/2" Split Lock	F05011-9	3
16	Bolt, 1/2-13 x 1" Hex Head Grade 8	F05008-128	3
	IDLER ASSEMBLY, #60 POWER FEED CHAIN	034228	1
17	Plate Weldment, Power Feed Idler	034227	1
18	Spacer, 41/64" x 1" x 3/16"	S12480	1
19	Sprocket, 60BB13H x 5/8" Idler	034224	1
20	Bolt, 5/8-18 x 2 1/4" Hex Head Grade 5	F05009-80	1
21	Nut, 5/8-18 Nylon Lock	F05010-71	1
22	Bolt, 1/2-13 x 2" Socket Head	F05008-133	2

7 Power Feed System

Feed Chain/Stop

23	CHAIN, #60 X 285" POWER FEED	003319 ²	1	
	CHAIN, #60 X 278 1/4' POWER FEED	036195 ²	1	
24	LINK, #60 MASTER	042398	2	

¹ Feed Stop Assembly 034557 modified Rev. A3.03 to make adjustable to accommodate various bed tube lengths. [See Section 7.5](#) for previous revisions.

² Use 003319 285" chain for Rev. A7.09 and later. Use 036195 278 1/4" chain for previous revisions.

7.5 Feed Chain/Stop

LT60HD/70HD

Rev. A3.01 - A9.00

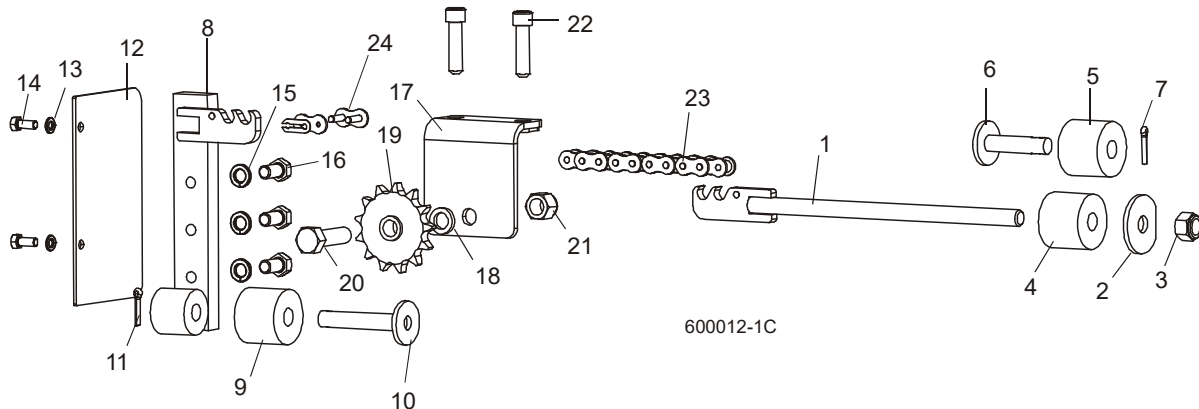

REF	DESCRIPTION (◆ Indicates Parts Available In Assemblies Only)	PART #	QTY.
	STOP ASSEMBLY, FRONT POWER FEED	034556	1
1	Tensioner Weldment, Power Feed Chain	034421	1
2	Washer, 21/32" x 2 1/4" x 3/16" D	017838	1
3	Nut, 5/8-11 Nylon Lock	F05010-34	1
4	Stop, Rubber Carriage	P12165	1
	Stop Kit, Rubber Carriage	K09630	2
5	Stop, Rubber Carriage	P12165	1
6	Pin, Rubber Carriage Stop	W09293	1
7	Pin, 3/16" X 1" Cotter	F05012-21	1
	STOP ASSEMBLY, REAR POWER FEED	034557 ¹	1
8	Stop Weldment, Rear Power Feed	034433 ¹	1
	Stop Kit, Rubber Carriage	K09630	2
9	Stop, Rubber Carriage	P12165	1
10	Pin, Rubber Carriage Stop	W09293	1
11	Pin, 3/16" X 1" Cotter	F05012-21	1
12	Plate, Bed Tube End	034455 ¹	1
13	Washer, 5/16" Split Lock	F05011-13	2
14	Bolt, 5/16-18 x 3/4" Hex Head	F05006-5	2
15	Washer, 1/2" Split Lock	F05011-9	3
16	Bolt, 1/2-13 x 1" Hex Head Grade 8	F05008-128	3
	IDLER ASSEMBLY, #60 POWER FEED CHAIN	034228	1
17	Plate Weldment, Power Feed Idler	034227	1
18	Spacer, 41/64" x 1" x 3/16"	S12480	1
19	Sprocket, 60BB13H x 5/8" Idler	034224	1
20	Bolt, 5/8-18 x 2 1/4" Hex Head Grade 5	F05009-80	1
21	Nut, 5/8-18 Nylon Lock	F05010-71	1

7 Power Feed System

Feed Chain/Stop

22	Bolt, 1/2-13 x 2" Socket Head	F05008-133	2	
23	CHAIN, #60 X 278 1/4' POWER FEED	036195	1	
24	LINK, #60 MASTER	042398	2	

¹ Feed Stop Assembly 034557 modified Rev. A3.03 to make adjustable to accommodate various bed tube lengths ([See Section 7.4](#)).

7.6 Lower Track Rollers

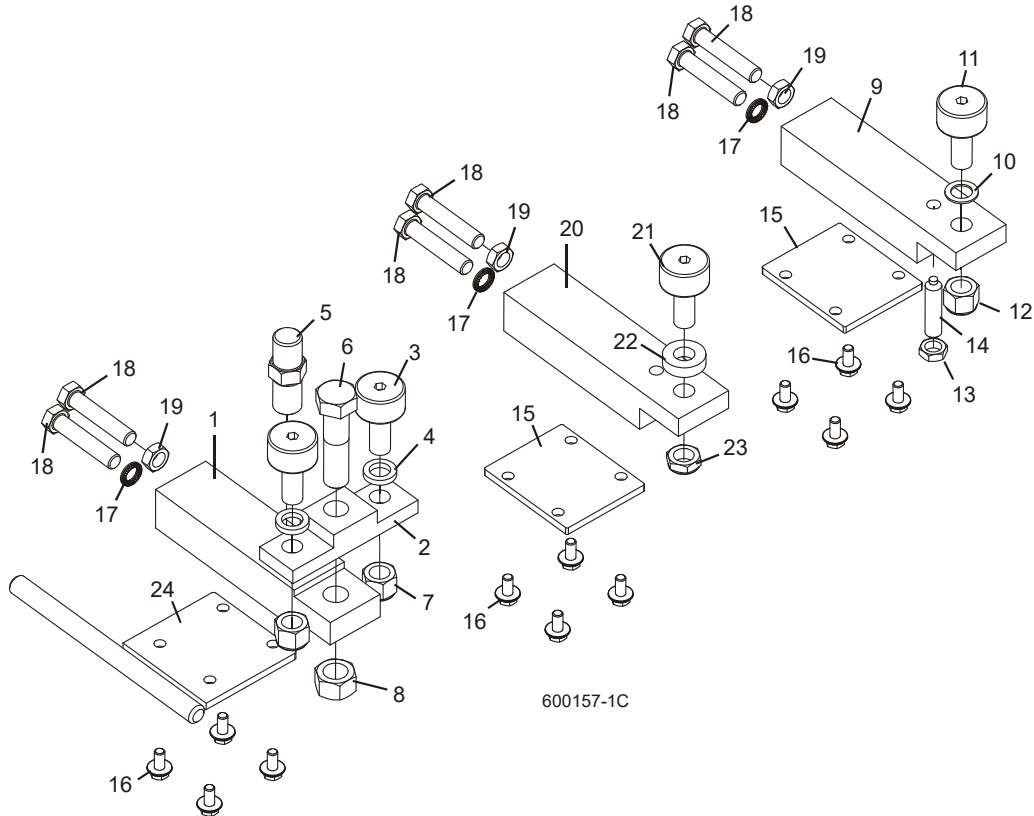

REF	DESCRIPTION (◆ Indicates Parts Available In Assemblies Only)	PART #	QTY.
	ROLLER ASSEMBLY, FRONT LOWER TRACK	036344	1
1	Block, Front Lower Track Roller Mount	036325	1
2	Block, Track Bearing Mount	042500	1
3	Bearing, 1 1/2" Track Roller	012797	2
4	Spacer, 41/64" x 1" x 3/16"	S12480	2
5	Pin, Safety Lock (Threaded)	036324	1
6	Bolt, 3/4-10 x 3" Hex Head Grade 5	F05013-5	1
7	Nut, 5/8-18 Hex Nylon Lock	F05010-101	2
8	Nut, 3/4-10 Hex Lock	F05010-80	1
	ROLLER ASSEMBLY, REAR LOWER TRACK	034232	1
9	Block, Rear Lower Track Roller Mount	034234	1
10	Shim, 5/8" x 1" x 1/16"	016510	1
11	Bearing, 1 1/2" Track Roller	012797	1
12	Nut, 5/8-18 Hex Jam	F05010-11	1
13	Nut, 1/2-13 Hex Jam	F05010-31	1
14	Screw, 1/2-13 x 2" Brass Tip Set	F05008-137	1
15	PLATE, LOWER TRACK ROLLER RETAINER	033880 ¹	2

7

Power Feed System*Lower Track Rollers*

16	BOLT, 5/16-18 X 3/4" HEX HEAD W/FLAT & LOCK WASHER	F05006-101 ²	12	
17	WASHER, 1/2" NORD-LOCK	F05011-125 ²	3	
18	BOLT, 1/2-20 X 2 1/2" HEX HEAD FULL THREAD GRADE 5	F05008-135	6	
19	NUT, 1/2-20 HEX JAM	F05010-16	3	
	ROLLER ASSEMBLY, MIDDLE LOWER TRACK	017887	1	
20	Block, Lower Track Roller Mount	034234	1	
21	Bearing, 1 1/2" Track Roller	012797	1	
22	Spacer	034674	1	
23	Nut, 5/8-18 Nylon Lock Jam	F05010-101	1	
24	PLATE WELDMENT, FRONT LOWER TRACK ROLLER W/DEFLECTOR	036473 ¹	1	

¹ One Retainer Plate 033880 replaced with Deflector Weldment 036473 at front track roller to prevent assembly from catching on remote cable chain (Rev. A3.02).

² Bolt with lock and flat washer F05006-101 replaces 5/16" Split Lock Washer F05011-13 and Hex Head Bolt F05006-102, Nord-Lock Washer F05011-125 replaces F05011-9 1/2" Split Lock Washer supplied prior to 4/10. Hardware changes with mast side plate revision provides increased fastener durability.

SECTION 8 BED FRAME ASSEMBLY

8.1 Bed Rail Assembly, Front And Rear

LT60HD
 LT70HD

Rev. A7.06 - B3.01
 Rev. A7.06 - B3.01

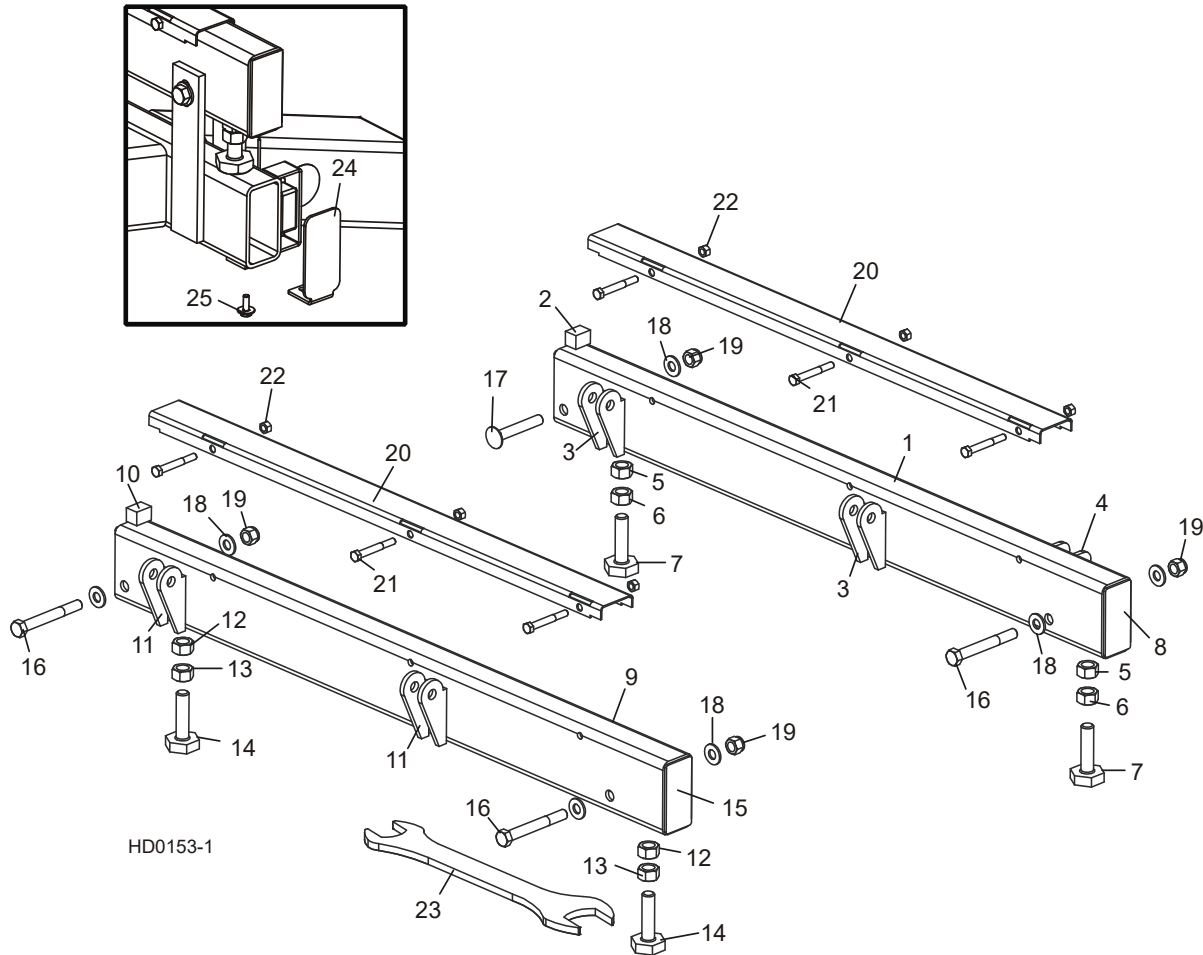

REF	DESCRIPTION (◆ Indicates Parts Available In Assemblies Only)	PART #	QTY.	
	BED RAIL ASSEMBLY, REAR PAINTED	014467	1	
1	Bed Rail Tube, Long	015974	1	◆
2	Block, Log Stop	S09034	1	
3	Bracket, Roller Toe Board Mount	S13021	4	◆
4	Bracket, Saw Head Rest Pin Mount	014150	2	◆
5	Nut, 5/8-11 Pilot Weld	F05010-84	2	
6	Nut, 5/8-11 Hex	F05010-5	2	
7	Bolt, Bed Rail Adjustment	S13006	2	
8	Plate, Bed Rail End Cap	S04058	2	◆
	BED RAIL ASSEMBLY, FRONT PAINTED	014455	1	

8

Bed Frame Assembly*Bed Rail Assembly, Front And Rear*

9	Bed Rail Tube, Long	015974	1	◆
10	Block, Log Stop	S09034	1	
11	Bracket, Roller Toe Board Mount	S13021	4	◆
12	Nut, 5/8-11 Pilot Weld	F05010-84	2	
13	Nut, 5/8-11 Hex	F05010-5	2	
14	Bolt, Bed Rail Adjustment	S13006	2	
15	Plate, Bed Rail End Cap	S04058	2	◆
16	BOLT, 1/2-13 X 4" HEX HEAD	F05008-78	3	
17	BOLT, 1/2-13 X 3 1/2" CARRIAGE	F05008-94 ¹	1	
18	WASHER, 1/2" SAE FLAT	F05011-2	7	
19	NUT, 1/2-13 NYLON LOCK	F05010-8	4	
20	COVER, STAINLESS STEEL BED RAIL	016898	2	
21	BOLT, 5/16-18 X 2 1/2" HEX HEAD	F05006-10	6	
22	NUT, 5/16-18 HEX LOCK	F05010-6	6	
23	WRENCH, BED RAIL ADJUSTMENT	015970	1	
24	CAP, BED RAIL REMOVABLE END	038843	2	
25	BOLT, 1/4-20 X 3/4" W/CONICAL WASHER HEAD	F05005-134	2	

¹ Used on rear bed rail to allow clearance for side support rollers.

8.2 Bed Rail Assembly, Front And Rear

LT60HD
LT70HD

Rev. A3.01 - A7.05
Rev. A3.01 - A7.05

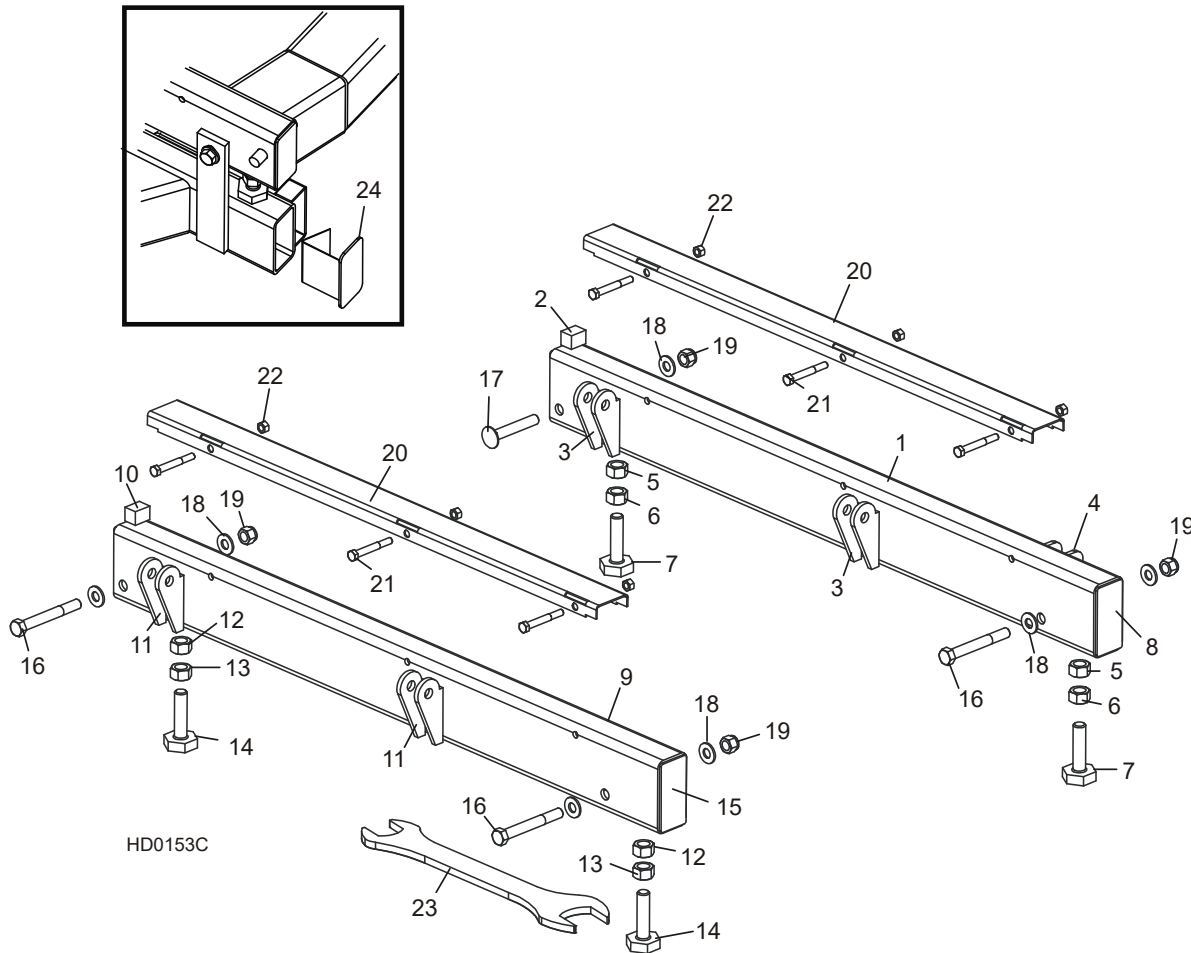

HD0153C

REF	DESCRIPTION (◆ Indicates Parts Available In Assemblies Only)	PART #	QTY.	
BED RAIL ASSEMBLY, REAR PAINTED		014467	1	
1	Bed Rail Tube, Long	015974	1	◆
2	Block, Log Stop	S09034	1	
3	Bracket, Roller Toe Board Mount	S13021	4	◆
4	Bracket, Saw Head Rest Pin Mount	014150	2	◆
5	Nut, 5/8-11 Pilot Weld	F05010-84	2	
6	Nut, 5/8-11 Hex	F05010-5	2	
7	Bolt, Bed Rail Adjustment	S13006	2	
8	Plate, Bed Rail End Cap	S04058	2	◆
BED RAIL ASSEMBLY, FRONT PAINTED		014455	1	
9	Bed Rail Tube, Long	015974	1	◆
10	Block, Log Stop	S09034	1	

8

Bed Frame Assembly*Bed Rail Assembly, Front And Rear*

11	Bracket, Roller Toe Board Mount	S13021	4	◆
12	Nut, 5/8-11 Pilot Weld	F05010-84	2	
13	Nut, 5/8-11 Hex	F05010-5	2	
14	Bolt, Bed Rail Adjustment	S13006	2	
15	Plate, Bed Rail End Cap	S04058	2	◆
16	BOLT, 1/2-13 X 4" HEX HEAD	F05008-78	3	
17	BOLT, 1/2-13 X 3 1/2" CARRIAGE	F05008-94 ¹	1	
18	WASHER, 1/2" SAE FLAT	F05011-2	7	
19	NUT, 1/2-13 NYLON LOCK	F05010-8	4	
20	COVER, STAINLESS STEEL BED RAIL	016898	2	
21	BOLT, 5/16-18 X 2 1/2" HEX HEAD	F05006-10	6	
22	NUT, 5/16-18 HEX LOCK	F05010-6	6	
23	WRENCH, BED RAIL ADJUSTMENT	015970	1	
24	CAP WELDMENT, BED RAIL REMOVABLE END	014652	2	

¹ Used on rear bed rail to allow clearance for side support rollers.

8.3 Bed Rail Assembly, Middle Front

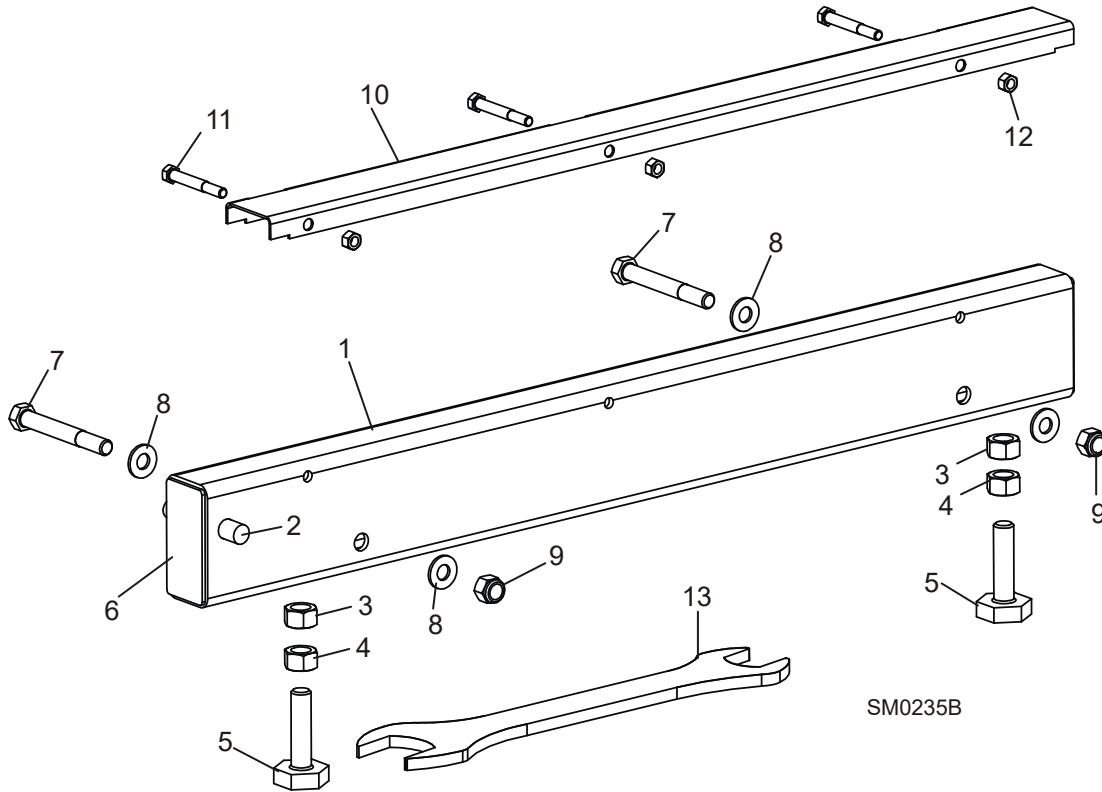

REF	DESCRIPTION (◆ Indicates Parts Available In Assemblies Only)	PART #	QTY.	
	BED RAIL ASSEMBLY, FRONT MIDDLE	A09566	1	
1	Bed Rail Tube, Short	S09103	1	◆
2	Pin, Ramp Mount	S04030	1	
3	Nut, 5/8-11 Pilot Weld	F05010-84	2	
4	Nut, 5/8-11 Hex	F05010-5	2	
5	Bolt, Bed Rail Adjustment	S13006	2	
6	Plate, Bed Rail End Cap	S04058	2	◆
7	BOLT, 1/2-13 X 4" HEX HEAD GRADE 5	F05008-78	2	
8	WASHER, 1/2" SAE FLAT	F05011-2	4	
9	NUT, 1/2-13 NYLON LOCK	F05010-8	2	
	COVER ASSEMBLY, STAINLESS STEEL BED RAIL (LONG)	A09956	1	
10	Cover, Stainless Steel Bed Rail	S09944	1	◆
11	Bolt, 5/16-18 X 2 1/2" Hex Head	F05006-10	3	
12	Nut, 5/16-18 Hex Lock	F05010-6	3	
13	WRENCH, BED RAIL ADJUSTMENT	015970	1	

8 Bed Frame Assembly

Bed Rail Assembly, Middle Rear

8.4 Bed Rail Assembly, Middle Rear

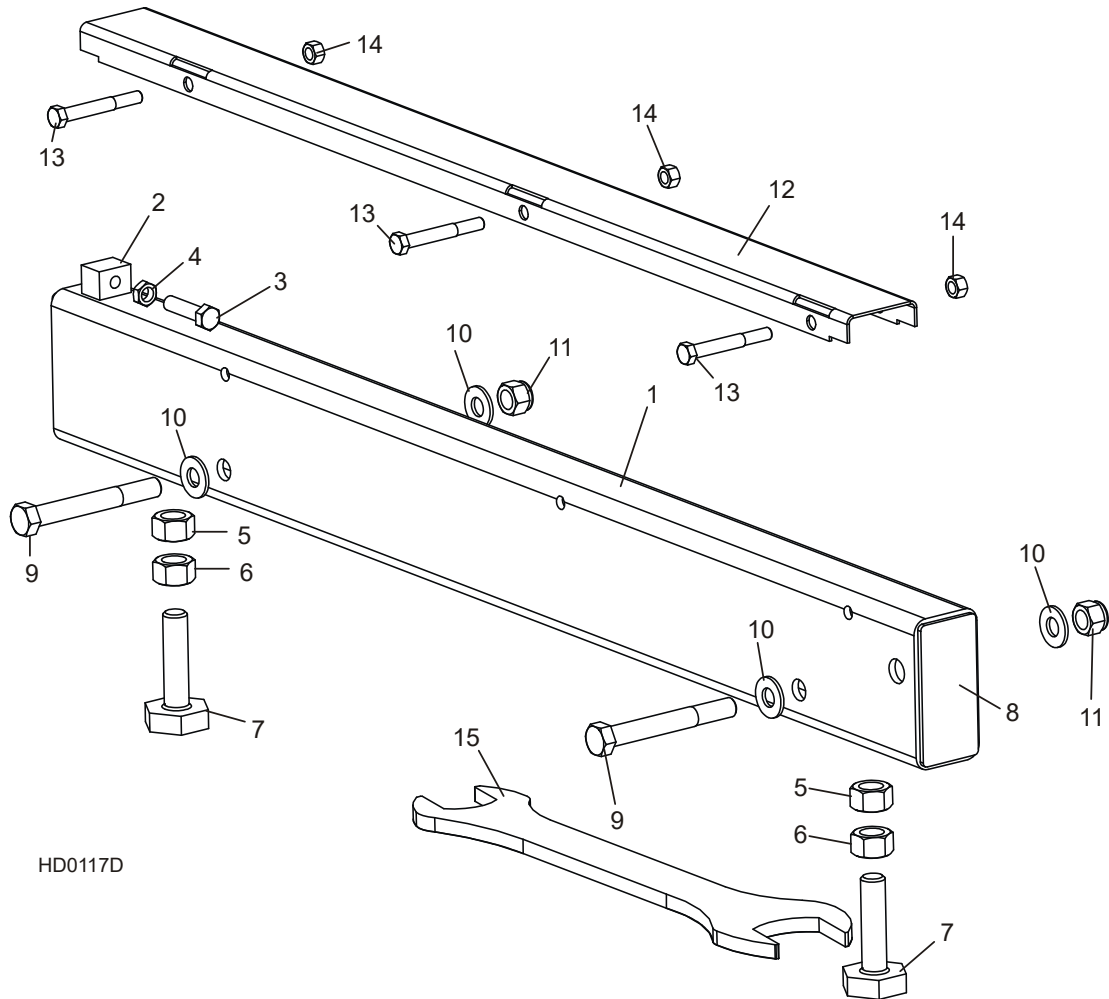

HD0117D

REF	DESCRIPTION (◆ Indicates Parts Available In Assemblies Only)	PART #	QTY.	
	BED RAIL ASSEMBLY, REAR MIDDLE PAINTED	015757	1	
1	Bed Rail Tube, Short	014640	1	◆
2	Block, Log Stop w/Threaded Hole	014639	1	◆
3	Bolt, 3/8-16 x 1 1/2 Full Thead Hex Head	F05007-17	1	
4	Nut, 3/8-16 Hex Jam	F05010-29	1	
5	Nut, 5/8-11 Square Pilot Weld	F05010-187	2	
6	Nut, 5/8-11 Hex	F05010-5	2	
7	Bolt, Bed Rail Adjustment	S13006	2	
8	Plate, Bed Rail End Cap	S04058	1	
9	BOLT, 1/2-13 X 4" HEX HEAD GRADE 5	F05008-78	2	
10	WASHER, 1/2" SAE FLAT	F05011-2	4	
11	NUT, 1/2-13 NYLON LOCK	F05010-8	2	

Bed Frame Assembly
Bed Rail Assembly, Middle Rear

8

	COVER ASSEMBLY, STAINLESS STEEL BED RAIL (LONG)	A09956	1	
12	Cover, Stainless Steel Bed Rail	S09944	1	◆
13	Bolt, 5/16-18 X 2 1/2" Hex Head	F05006-10	3	
14	Nut, 5/16-18 Hex Lock	F05010-6	3	
15	WRENCH, BED RAIL ADJUSTMENT	015970	1	

8 **Bed Frame Assembly**
Leg Assembly (Stationary)

8.5 Leg Assembly (Stationary)

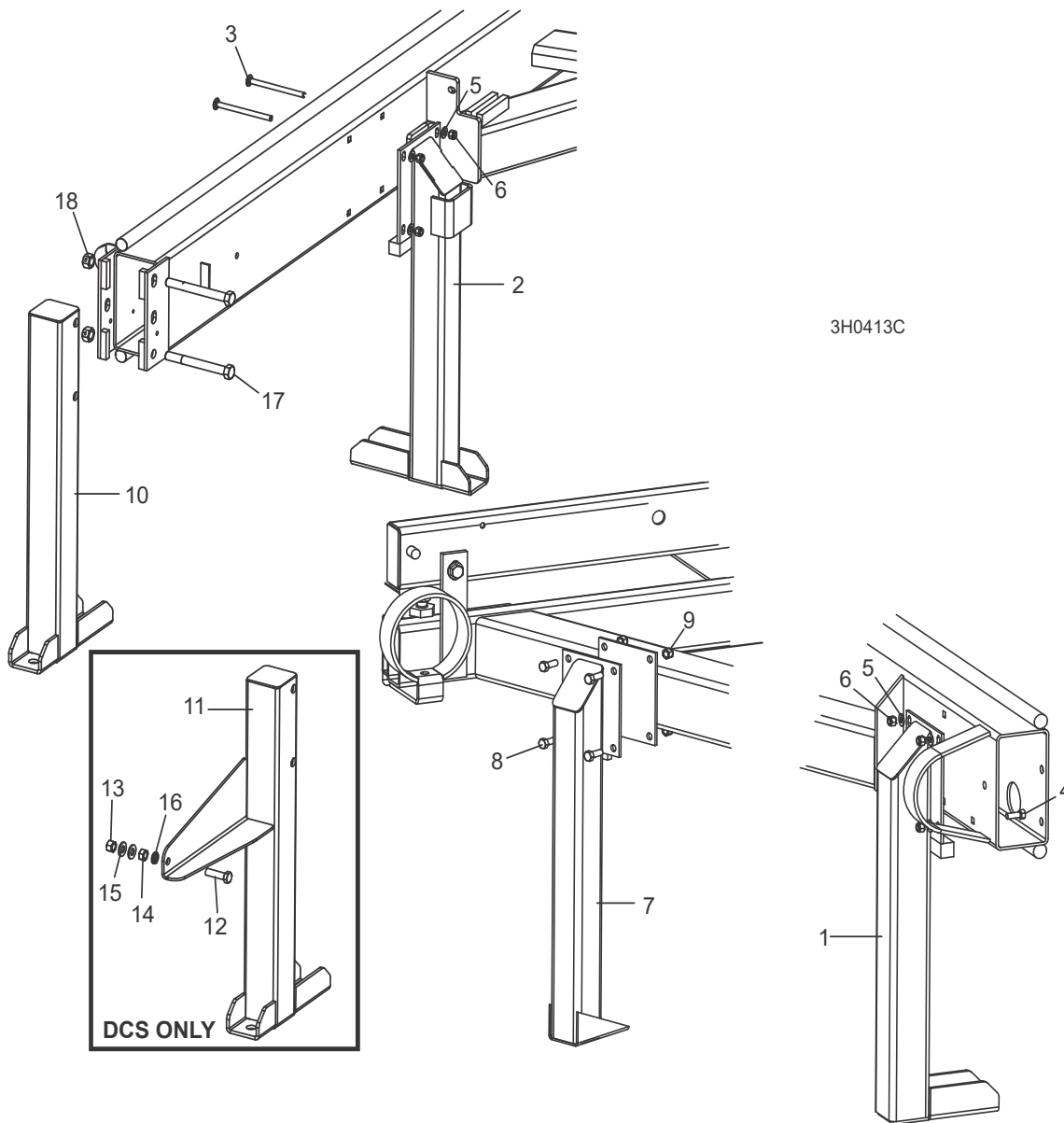

REF	DESCRIPTION (◆ Indicates Parts Available In Assemblies Only)	PART #	QTY.
1	LEG, LONG STATIONARY (1 REQ'D FOR LT60HD; 3 REQ'D FOR LT70HD)	W09513	1/3
2	LEG, LONG STATIONARY W/BOARD RETURN TABLE BRACKET	015091	1
3	BOLT, 3/8-16 X 5" CARRIAGE HEAD	F05007-113	8/12
4	BOLT, 3/8-16 X 1 1/4" HEX HEAD (REQ'D FOR REAR LT70HD ONLY)	F05007-2	4
5	WASHER, 3/8" SAE FLAT	F05011-3	8/16
6	NUT, 3/8-16 HEX NYLON LOCK	F05010-10	8/16

Bed Frame Assembly
Leg Assembly (Stationary)

8

7	LEG, SHORT STATIONARY	W09515	2	
8	BOLT, 3/8-16 X 1 1/4" HEX HEAD	F05007-2	8	
9	NUT, 3/8-16 HEX NYLON LOCK	F05010-10	8	
10	LEG, FRONT STATIONARY	W09517	1	
11	BOLT, 5/8-11 X 5 1/2" HEX HEAD GRADE 5	F05009-11	2	
12	NUT, 5/8-11 HEX LOCK	F05010-4	2	

8 Bed Frame Assembly

Board Return Table Assembly

8.6 Board Return Table Assembly

LT60HD/70HD

Rev. A7.09 - B3.01

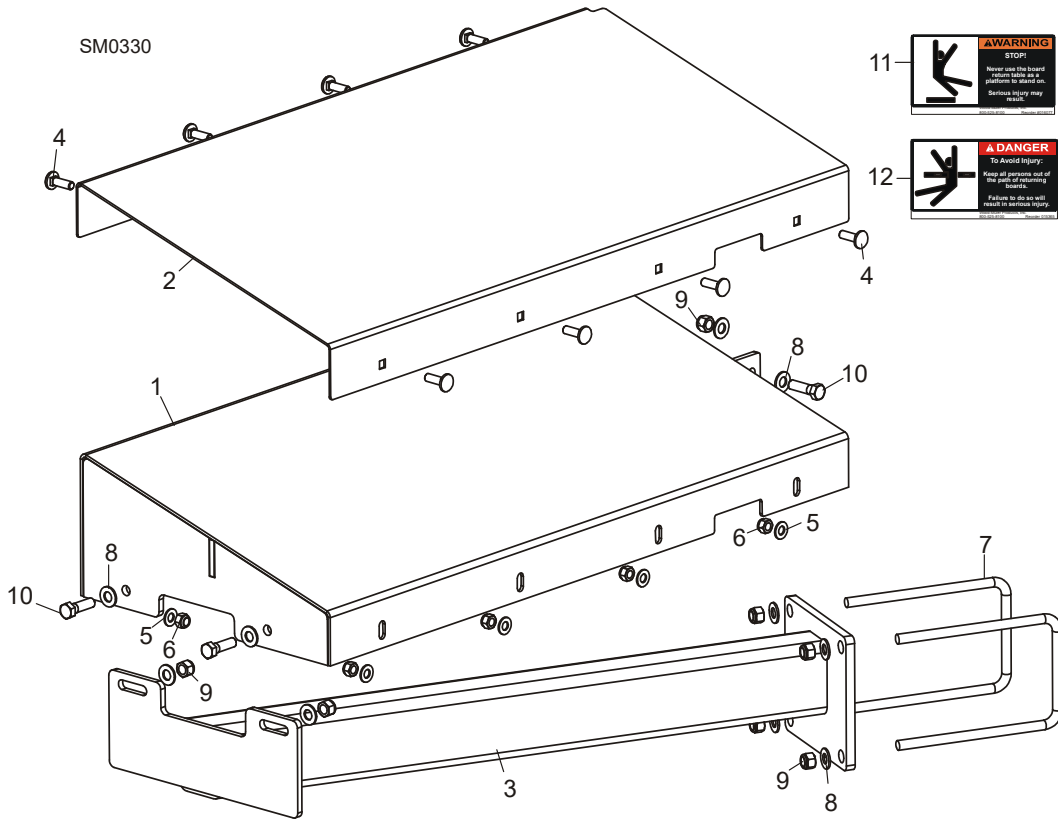

REF	DESCRIPTION (◆ Indicates Parts Available In Assemblies Only)	PART #	QTY.
	TABLE ASSEMBLY, BOARD RETURN (LT70)	003264	1
	TABLE ASSEMBLY, BOARD RETURN (LT60)	003270	1
1	Table Weldment, Board Return	055515	1
2	Cover, Board Return Table	003259	1
3	Mount Weldment, Board Return Table (LT70)	055533	1
	Mount Weldment, Board Return Table (LT60)	038992	1
4	Bolt, 5/16-18 x 1" Carriage Head	F05006-9	8
5	Washer, 5/16" SAE Flat	F05011-17	8
6	Nut, 5/16-18 Nylon Lock	F05010-58	8
7	Bolt, 3/8-16 x 4" x 5" 'U'	003207	2
8	Washer, 3/8" SAE Flat	F05011-3	10
9	Nut, 3/8-16 Hex Nylon Lock	F05010-10	7
10	Bolt, 3/8-16 x 1 1/4" Hex Head Grade 5	F05007-123	3
11	Decal, Board Return Table Warning	016077	1
12	Decal, Board Return Danger	015365	1

8.7 Board Return Table Assembly

LT60HD/70HD

Rev. A3.01 - A7.08

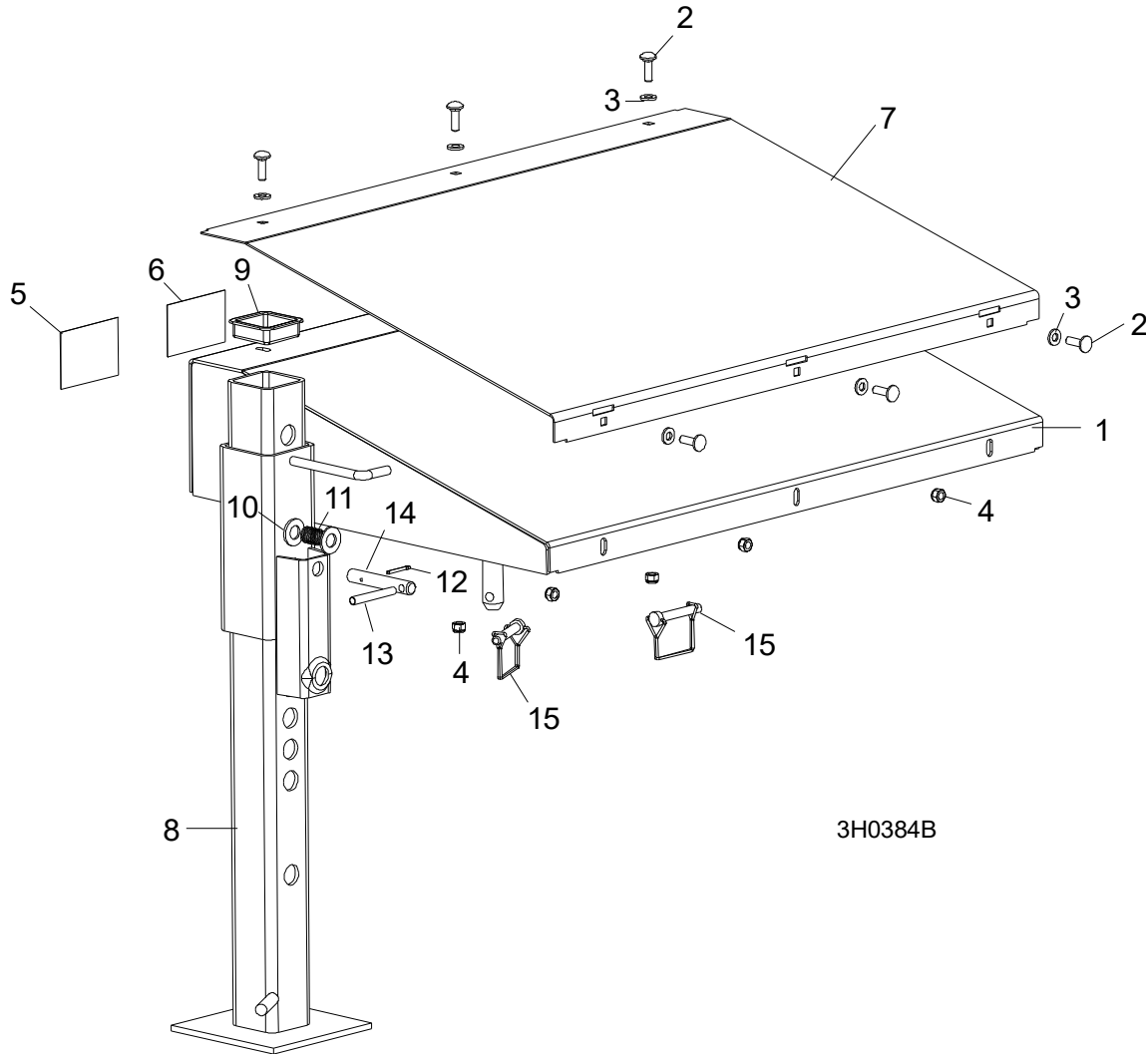

REF	DESCRIPTION (◆ Indicates Parts Available In Assemblies Only)	PART #	QTY.	
	TABLE ASSEMBLY, BOARD RETURN	015792	1	
1	Table Weldment, Board Return	015790	1	◆
2	Bolt, 5/16-18 x 1" Carriage Head	F05006-9	6	
3	Washer, 5/16" SAE Flat	F05011-17	6	
4	Nut, 5/16-18 Nylon Lock	F05010-58	6	
5	Decal, Board Return Danger	015365	1	
6	Decal, Board Return Table Warning	016077	1	
7	Plate, Return Table Stainless Steel	015791	1	
8	Leg Weldment, Painted Outrigger	W07537	1	

8 **Bed Frame Assembly**
Board Return Table Assembly

9	Cap, Outrigger Leg	P09926	1	
10	Washer, 3/4" SAE Flat	F05011-62	2	
11	Spring, Outrigger Pin	016145	1	
12	Pin, 1/8" X 1 1/4" Cotter	F05012-59	1	
	Pin Kit, 3/4" Outrigger Pull	016148	1	
13	Pin, 5/16" X 2 1/2" Roll	F05012-47	1	
14	Pin, 3/4" Outrigger Pull	016147	1	◆
15	Pin, 3/8 X 2 1/4" Square Wire Lock	014151	2	

8.8 Pivot Bed Rail Assembly

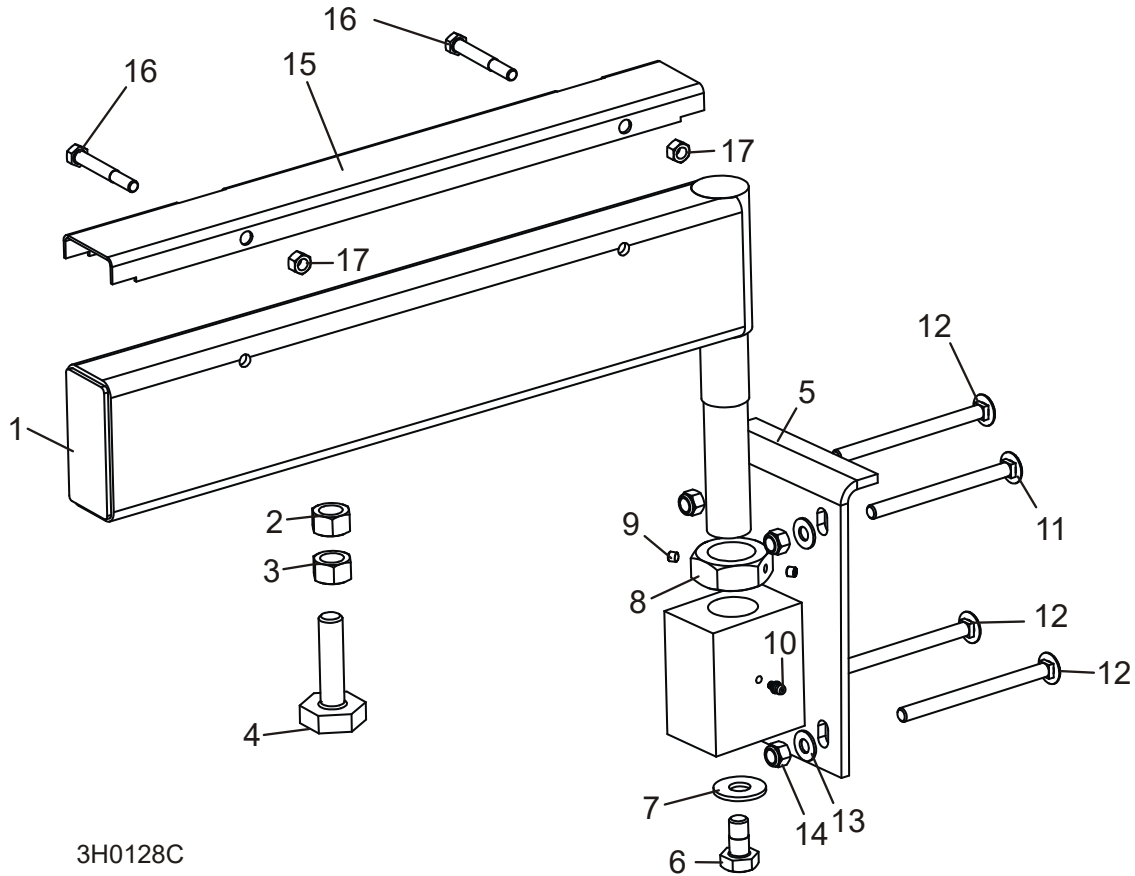

REF	DESCRIPTION (◆ Indicates Parts Available In Assemblies Only)	PART #	QTY.	
	PIVOT BED RAIL ASSEMBLY (LT70HD)	A13015	2	
	PIVOT BED RAIL ASSEMBLY (LT60HD)	012993	2	
1	Pivot Bed Rail Weldment (LT70HD)	W13014	1	◆
	Pivot Bed Rail Weldment (LT60HD)	012992	1	◆
2	Nut, 5/8-11 Pilot Weld	F05010-84	2	
3	Nut, 5/8-11 Hex	F05010-5	2	
4	Bolt, Bed Rail Adjustment	S13006	2	
5	Bracket, Pivot Rail Mounting	W13090	1	
6	Bolt, 1/2-13 x 1" Hex Head Grade 2	F05008-50	1	
7	Washer, 9/16" SAE Flat	F05011-52	1	
8	Nut, Pivot Rail Adjustment	S13016	1	
9	Screw, 1/4-28 x 1/4" Brass Tip Set	F05005-42	2	
10	Fitting, 3/16" Grease	P04107	1	
11	BOLT, 3/8-16 X 4 3/4" CARRIAGE HEAD	F05007-114	2	

8

Bed Frame Assembly*Pivot Bed Rail Assembly*

12	BOLT, 3/8-16 X 5" CARRIAGE HEAD	F05007-113	6	
13	WASHER, 3/8" SAE FLAT	F05011-3	8	
14	NUT, 3/8-16 NYLON LOCK	F05010-10	8	
	COVER KIT, PIVOT RAIL STAINLESS STEEL (LT70HD)	017710	2	
	COVER KIT, PIVOT RAIL STAINLESS STEEL (LT60HD)	015926	2	
15	Cover, Stainless Steel Pivot Bed Rail (LT70HD)	S13012	1	
	Cover, Stainless Steel Pivot Bed Rail (LT60HD)	012994	1	
16	Bolt, 5/16-18 X 2 1/2" Hex Head	F05006-10	2	
17	Nut, 5/16-18 Hex Lock	F05010-6	2	
	WRENCH, BED RAIL ADJUSTMENT (See Section 8.1)	015970	1	

8.9 Log Side Support Assembly (Manual)

[See Section 10.16](#) for hydraulic side supports

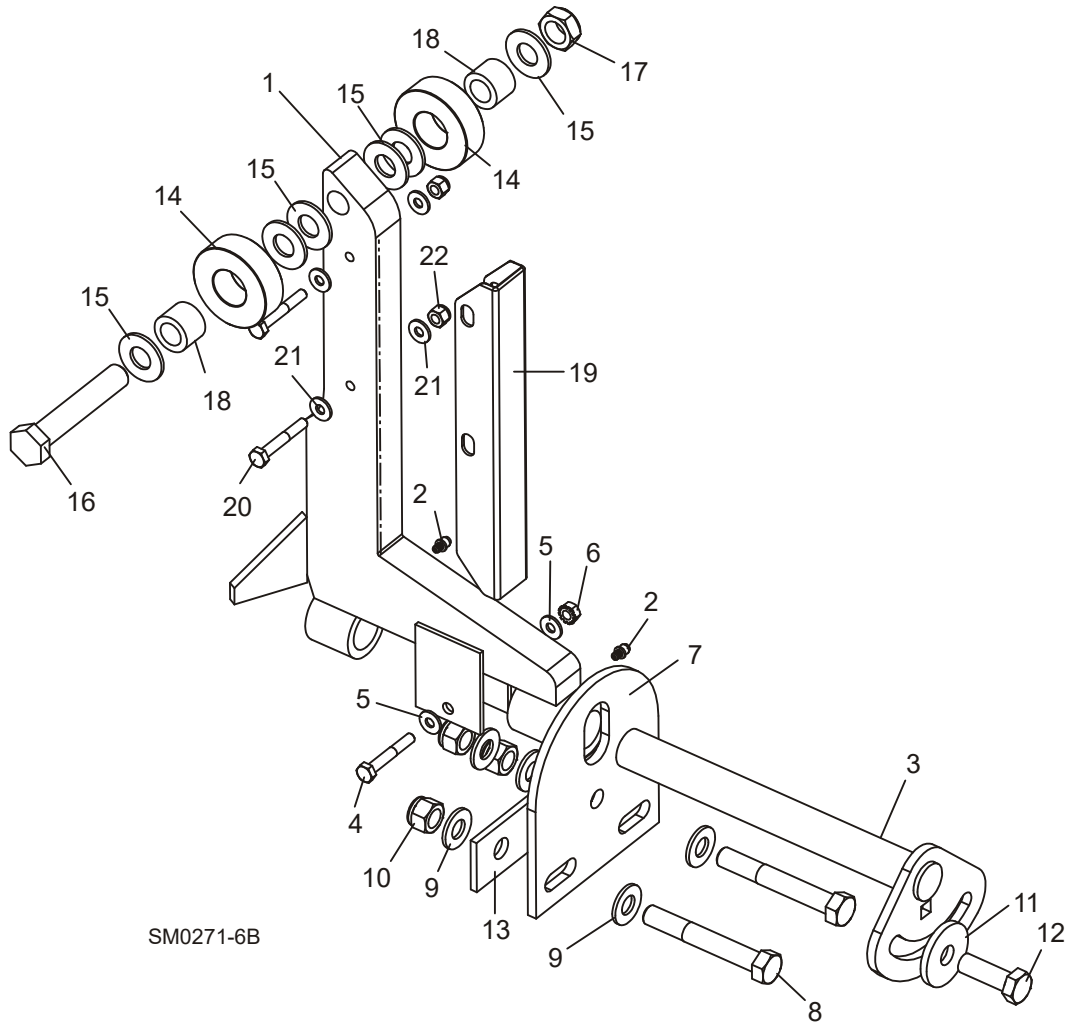

REF	DESCRIPTION (◆ Indicates Parts Available In Assemblies Only)	PART #	QTY.
1	SUPPORT, LOG SIDE	015235	2
2	Fitting, 3/16" Grease	P04107	2
	MOUNTING KIT, LOG SIDE SUPPORT	016559	2
3	Pin, Log Side Support Pivot	016544	1
4	Bolt, 1/4-20 X 1 1/2" Hex Head Grade 5	F05005-4	1
5	Washer, 1/4" SAE Flat	F05011-11	2
6	Nut, 1/4-20 Self Locking	F05010-9	1
7	Plate, Log Side Support End	016555	1
8	Bolt, 1/2-13 X 3 1/2" Hex Head Grade 5	F05008-61	2

8

Bed Frame Assembly*Log Side Support Assembly (Manual)*

9	Washer, 1/2" SAE Flat	F05011-2	5	
10	Nut, 1/2-13 Hex Nylon Lock	F05010-8	3	
11	Washer, .52" x 1.69"	014632 ¹	1	
12	Bolt, 1/2-13 X 1 1/2" Hex Head Grade 5	F05008-33	1	
13	Plate, Side Support Washer Clamp	016558	1	
	ROLLER KIT, SIDE SUPPORT (OPTIONAL)	016562	4	
14	Roller, Side Support	016561	2	
15	Washer, 5/8" SAE Flat	F05011-5 ²	6	
16	Bolt, 5/8-11 x 3 3/4" Hex Head Grade 5	F05009-118 ³	1	
17	Nut, 5/8-11 Hex Nylon Lock Jam	F05010-96	1	
18	Bushing, Bronze 5/8" x 1" x 3/4"	016560	2	
	Bolt, 1/2-13 x 3 1/2" Carriage Head	F05008-94	1	
	Instruction Sheet, Side Support Roller	016562-526	1	
	GUARD KIT, STAINLESS STEEL SIDE SUPPORT	016798	1	
19	Guard, Stainless Steel Side Support	016722	4	
20	Bolt, 1/4-20 x 1 3/4" Hex Head	F05005-4	8	
21	Washer, 1/4" SAE Flat	F05011-11	16	
	Washer, 5/8" SAE Flat	F05011-5 ²	4	
22	Nut, 1/4-20 Hex Nylon Lock	F05010-69	8	
	Instruction Sheet, Stainless Steel Side Support Guard Retro	016798-1005	1	

¹ Oversized Washer 014632 replaces 1/2" SAE Flat Washer F05011-2 to provide larger clamping area during adjustment (Rev. B3.01).

² Additional 5/8" SAE Flat Washer F05011-5 may be required on each side of side support to provide clearance for optional stainless steel side support guards. Extra washers are included in the stainless steel guard retrofit kit (016798).

³ Longer bolt replaces 3 1/2" F05009-93 used before 3/07.

8.10 Safety Chain Assembly

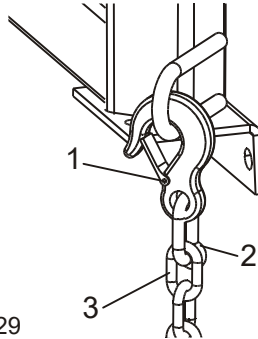

REF	DESCRIPTION (◆ Indicates Parts Available In Assemblies Only)	PART #	QTY.	
	CHAIN ASSEMBLY, TIE DOWN	A04376	1	
1	Hook, 5/8" Safety Chain	P12075	1	◆
2	Cold Shut, 3/8" Plain	P04772-2	1	◆
3	Chain, 5/16" Unplated	R02111	.938 ft.	◆

8 **Bed Frame Assembly**
Saw Head Rest Pin Assembly

8.11 Saw Head Rest Pin Assembly

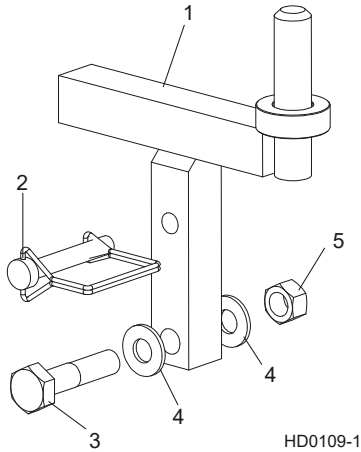

REF	DESCRIPTION (◆ Indicates Parts Available In Assemblies Only)	PART #	QTY.	
1	PIN, SAW HEAD REST	034442	1	
2	PIN, 3/8" X 2 1/4" SNAP RETAINER	014151	1	
3	BOLT, 1/2-13 X 2 1/4" HEX HEAD GRADE 5	F05008-10	1	
4	WASHER, 1/2" SAE FLAT	F05011-2	2	
5	NUT, 1/2-13 HEX LOCK	F05010-3	1	

8.12 Bed Frame Decals

LT70HD

Rev. A8.00 (1/08) - B3.01

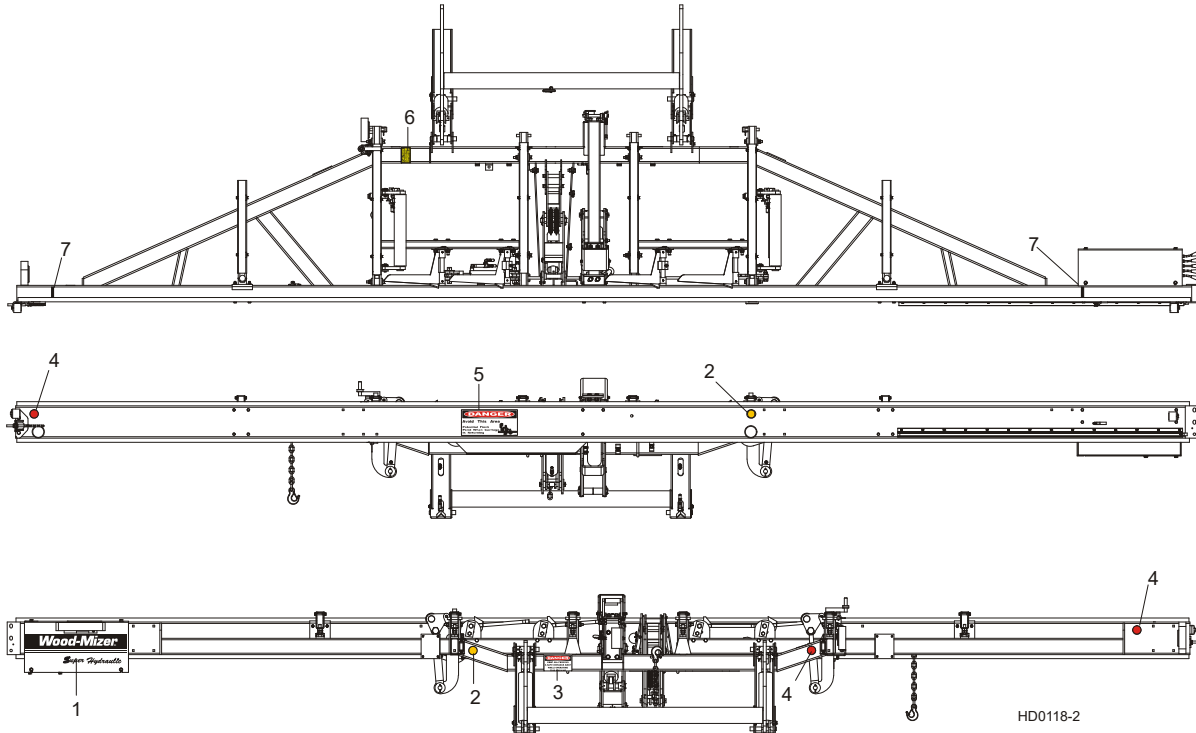

REF	DESCRIPTION (◆ Indicates Parts Available In Assemblies Only)	PART #	QTY.
1	DECAL, WOOD-MIZER LT70HD LOGO	003253	1
2	DECAL, AMBER REFLECTIVE 2" ROUND	P07453	2
3	DECAL, KEEP AWAY DANGER	S09851	1
4	DECAL, RED REFLECTIVE 2" ROUND	P07452	3
5	DECAL, PINCH POINT DANGER	P10287	1
6	DECAL, SAW HEAD REST CAUTION	S12581	1
7	DECAL, LOG LIMIT STRIPE	S12051	2

8.13 Bed Frame Decals

LT70HD

Rev. A3.01 - A8.00 (12/07)

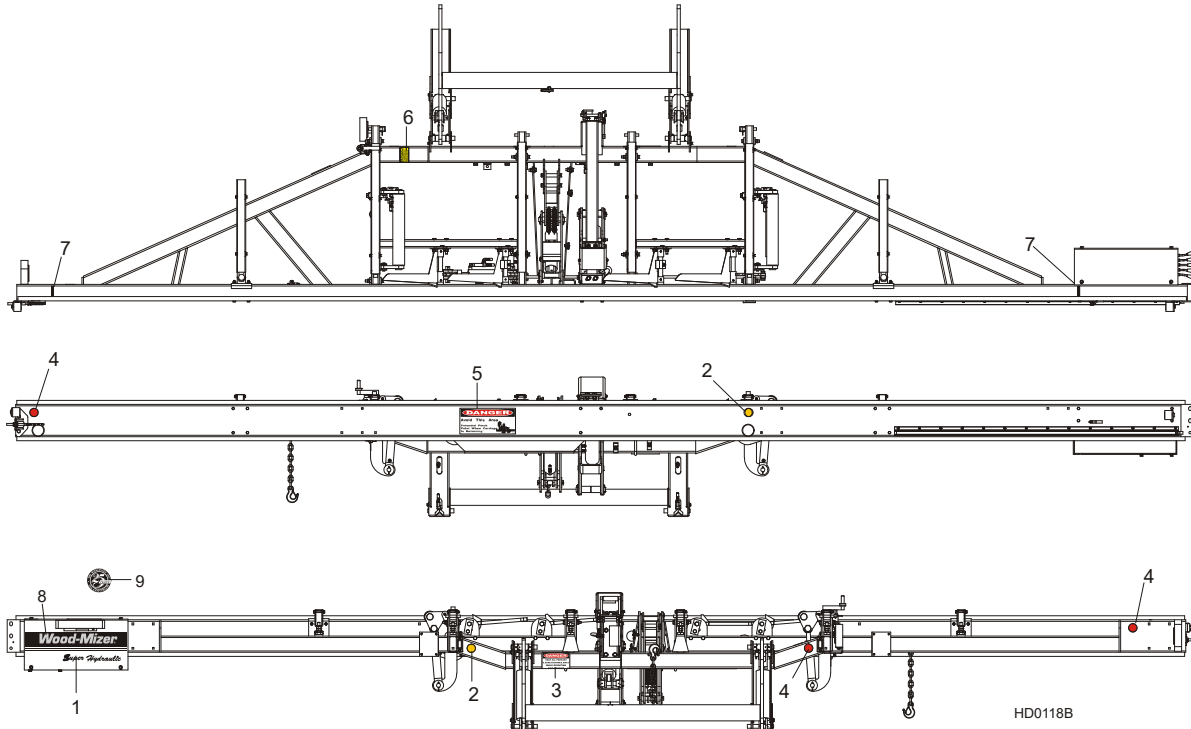

REF	DESCRIPTION (◆ Indicates Parts Available In Assemblies Only)	PART #	QTY.
1	DECAL, WOOD-MIZER LT70HD LOGO	003253 ¹	1
2	DECAL, AMBER REFLECTIVE 2" ROUND	P07453	2
3	DECAL, KEEP AWAY DANGER	S09851	1
4	DECAL, RED REFLECTIVE 2" ROUND	P07452	3
5	DECAL, PINCH POINT DANGER	P10287	1
6	DECAL, SAW HEAD REST CAUTION	S12581	1
7	DECAL, LOG LIMIT STRIPE	S12051	2
8	DECAL, SILVER WOOD-MIZER LOGO	003234 ¹	1
9	DECAL, ANNIVERSARY LOGO	003237 ¹	1

¹ LT70HD Logo 036649 replaced with new logo decals 1/07.

8.14 Board Outfeed Table (Optional)

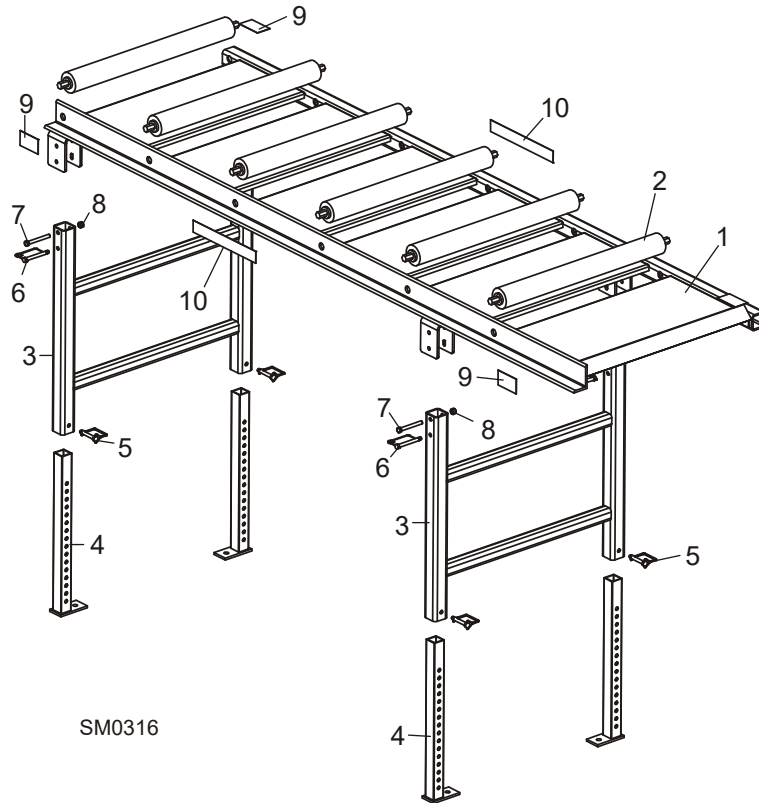

REF	DESCRIPTION (◆ Indicates Parts Available In Assemblies Only)	PART #	QTY.
	TABLE ASSEMBLY, BOARD OUTFEED	016652	1
1	Table Weldment, Board Outfeed	016606	1
2	Roller, 2 1/2" x 25"	038167	6
3	Mount Weldment, Outfeed Table Leg	016609	2
4	Leg Weldment, Outfeed Table	016651	4
5	Pin, 3/8" x 2 1/4" Square Wire Lock	014151	4
6	Pin, Snap - Coil Tension	016677	4
7	Bolt, 3/8-16 x 3 1/4" Hex Head	F05007-135	4
8	Nut, 3/8-16 Hex Nylon Lock	F05010-10	4
9	Decal, Hand Pinch Point Warning	S12641	4
10	Decal, 1 1/2" Wood-Mizer Logo	016991	2

SECTION 9 MISCELLANEOUS

9.1 Replacement Manuals

REF	DESCRIPTION (◆ Indicates Parts Available In Assemblies Only)	PART #	QTY.
Wood-Mizer Product Information			
1	ALL-PRODUCTS CATALOG	PS750	1
Basic Sawmill Manuals			
2	TRU-SHARP BLADE HANDBOOK	M600	1
3	WOOD-MIZER GENERAL INFORMATION	M601	1
4	LT60HD/LT70HD OPERATOR'S MANUAL	M1189	1
5	LT70HD-WR WIRELESS OPERATOR'S MANUAL	M1550	1
6	LT60HD/70HD PARTS MANUAL	M1179	1
7	LT70HD-WR WIRELESS PARTS MANUAL	M1552	1
Power Option Manuals			
8	E25 MOTOR OPTION MANUAL	M1082	1
9	D42 ENGINE OPTION MANUAL	M1067	1
10	D51 ENGINE OPTION MANUAL	M1146	1
11	D55 ENGINE OPTION MANUAL	M1589	1
12	D62 ENGINE OPTION MANUAL	M1138	1
13	KUBOTA OPERATOR'S MANUAL	028555	1
14	KUBOTA SERVICE MANUAL	028566	1
15	KUBOTA PARTS MANUAL (1505TE)	028565	1
Trailer Option Manuals			
16	SUPER ELECTRIC BRAKE TRAILER OPTION	M797	1
17	SUPER SURGE BRAKE TRAILER OPTION	M795	1
Miscellaneous Option Manuals			
18	SHINGLE/LAPSIDER OPTION MANUAL	M621	1
19	OPERATOR'S SEAT OPTION MANUAL	M613	1
20	RESAW ATTACHMENT OPTION MANUAL	M263	1
21	BED EXTENSION OPTION MANUAL	M294	1
22	DEBARKER OPTION MANUAL (DC)	M1059	1
23	DEBARKER OPTION MANUAL (AC)	M1105	1
24	ACCUSET 2 OPTION MANUAL	M1521	1
25	ACCUSET OPTION MANUAL (AC)	M1112	1
26	ACCUSET OPTION MANUAL (DC)	M1087	1
27	LASER SIGHT OPTION MANUAL	M1081	1
28	LUBE-MIZER OPTION MANUAL	M885	1
29	LATHE-MIZER OPTION MANUAL	M1337	1
Electrical Diagrams			
30	E25-H ELECTRICAL INFORMATION	M1088	1
31	E25-L ELECTRICAL INFORMATION	M1090	1
32	E25-C ELECTRICAL INFORMATION	M1092	1
33	E25-H-WR WIRELESS ELECTRICAL INFORMATION	M1558	1

34	E25-L-WR WIRELESS ELECTRICAL INFORMATION	M1559	1
35	E25-C-WR WIRELESS ELECTRICAL INFORMATION	M1557	1
36	D42 ELECTRICAL INFORMATION	M1071	1
37	D51/D62 ELECTRICAL INFORMATION	M1141	1
38	D55 ELECTRICAL INFORMATION	M1590	1
39	D51/D62-WR WIRELESS ELECTRICAL INFORMATION	M1556	1
40	D55-WR WIRELESS ELECTRICAL INFORMATION	M1592	1

SECTION 10 HYDRAULIC SYSTEM

10.1 Hydraulic Hoses

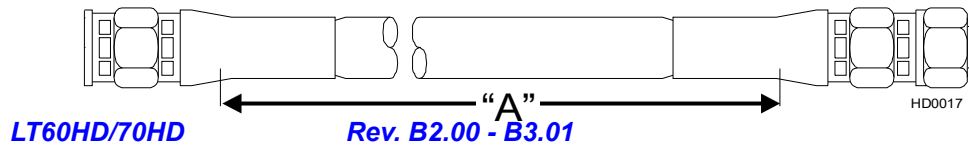

ID	Color Code	LENGTH "A"	Application	PART #
H1	Purple	197"	1/4" Rear Toe Board Top (LT60HD)	014791
		219"	1/4" Rear Toe Board Top (LT70HD)	018026
H2	Black	197"	1/4" Rear Toe Board Base (LT60HD)	014791
		219"	1/4" Rear Toe Board Base (LT70HD)	018026
H3	Yellow	95"	1/4" Front Toe Board Top (LT60HD)	P12540
		117"	1/4" Front Toe Board Top (LT70HD)	P12542
H4	Gray	95"	1/4" Front Toe Board Base (LT60HD)	P12540
		117"	1/4" Front Toe Board Base (LT70HD)	P12542
H5	Green	182"	1/4" Clamp Up/Down Top (LT60HD)	014788
		204"	1/4" Clamp Up/Down Top (LT70HD)	014792
H6	Yellow	171"	1/4" Clamp Up/Down Base (LT60HD)	P12549
		193"	1/4" Clamp Up/Down Base (LT70HD)	015692
H7	Red	156"	3/8" Loading Arm Base (LT60HD)	048290
		178"	3/8" Loading Arm Base (LT70HD)	048291
H8	Blue	156"	3/8" Loading Arm Top (LT60HD)	048290
		178"	3/8" Loading Arm Top (LT70HD)	048291
H9	Orange	65"	3/8" Side Support Base	048292
H10	Plain	73"	3/8" Side Support Top	048293
H11	Orange	181"	3/8" Clamp In/Out Base (LT60HD)	048294
		177"	3/8" Clamp In/Out Base (LT70HD)	048295
H12	White	129"	3/8" Clamp In/Out Top (LT60HD)	048296
		151"	3/8" Clamp In/Out Top (LT70HD)	048297
H13	Green	38"	3/8" Loading Arm Branch Top	006875 ¹
H14	Green	77"	3/8" Loading Arm Branch Top	048298
H15	Yellow	81"	3/8" Loading Arm Branch Base	048299
H16	Yellow	43"	3/8" Loading Arm Branch Base	048300
H17	Plain	159"	3/8" Log Turner Base (LT60HD)	048301
		181"	3/8" Log Turner Base (LT70HD)	048294
H18	Pink	159"	3/8" Log Turner Top (LT60HD)	048301
		181"	3/8" Log Turner Top (LT70HD)	048294
H19	Purple	164"	3/8" Log Turner Motor Top (LT60HD)	048302
		177"	3/8" Log Turner Motor (LT70HD Nearest Frame)	006723

H20	Black	163"	3/8" Log Turner Motor Base (LT60HD)	048304
		180"	3/8" Log Turner Motor (LT70HD Furthest from Frame)	006724
H21	Plain	15"	1/4" Pump To Valve (two hoses)	057964
H22	Plain	6 1/2"	3/8" Gauge To Valve	036303

¹ Replaces 048292 supplied prior to 11/08. 048292 was modified to 65" for new log turner.

10.2 Hydraulic Hoses

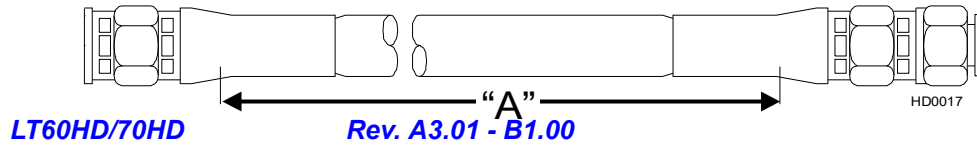

ID	Color Code	LENGTH "A"	Application	PART #
H1	Purple	197"	1/4" Rear Toe Board Top (LT60HD)	014791
		219"	1/4" Rear Toe Board Top (LT70HD)	018026
H2	Black	197"	1/4" Rear Toe Board Base (LT60HD)	014791
		219"	1/4" Rear Toe Board Base (LT70HD)	018026
H3	Yellow	95"	1/4" Front Toe Board Top (LT60HD)	P12540
		117"	1/4" Front Toe Board Top (LT70HD)	P12542
H4	Gray	95"	1/4" Front Toe Board Base (LT60HD)	P12540
		117"	1/4" Front Toe Board Base (LT70HD)	P12542
H5	Green	182"	1/4" Clamp Up/Down Top (LT60HD)	014788
		204"	1/4" Clamp Up/Down Top (LT70HD)	014792
H6	Yellow	171"	1/4" Clamp Up/Down Base (LT60HD)	P12549
		193"	1/4" Clamp Up/Down Base (LT70HD)	015692
H7	Red	156"	3/8" Loading Arm Base (LT60HD)	048290
		178"	3/8" Loading Arm Base (LT70HD)	048291
H8	Blue	156"	3/8" Loading Arm Top (LT60HD)	048290
		178"	3/8" Loading Arm Top (LT70HD)	048291
H9	Orange	65"	3/8" Side Support Base	048292 ¹
H10	Plain	73"	3/8" Side Support Top	048293 ¹
H11	Orange	181"	3/8" Clamp In/Out Base (LT60HD)	048294
		177"	3/8" Clamp In/Out Base (LT70HD)	048295
H12	White	129"	3/8" Clamp In/Out Top (LT60HD)	048296
		151"	3/8" Clamp In/Out Top (LT70HD)	048297
H13	Green	38"	3/8" Loading Arm Branch Top	006875 ²
H14	Green	77"	3/8" Loading Arm Branch Top	048298 ³
H15	Yellow	81"	3/8" Loading Arm Branch Base	048299
H16	Yellow	43"	3/8" Loading Arm Branch Base	048300
H17	Plain	159"	3/8" Log Turner Base (LT60HD)	048301
		181"	3/8" Log Turner Base (LT70HD)	048294
H18	Pink	159"	3/8" Log Turner Top (LT60HD)	048301
		181"	3/8" Log Turner Top (LT70HD)	048294
H19	Purple	164"	3/8" Log Turner Motor Top (LT60HD)	048302
		186"	3/8" Log Turner Motor Top (LT70HD)	048303

H20	Black	163"	3/8" Log Turner Motor Base (LT60HD)	048304
		185"	3/8" Log Turner Motor Base (LT70HD)	048305
H21	Plain	15"	1/4" Pump To Valve (two hoses)	057964 ⁴
H22	Plain	6 1/2"	3/8" Gauge To Valve	036303

¹ Hoses lengthened 7" to accommodate new log turner 11/08.

² Replaces 048292 supplied prior to 11/08. 048292 was modified to 65" for new log turner.

³ Hose lengthened 2" to improve routing to new 7-Section valve used for Remote models (Rev. A6.00).

⁴ Hose kit 057964 replaces individual hoses 036292 originally supplied prior to 6/08. Kit includes two hoses and instructions to reroute the hoses to avoid abrasion against pump motor terminal which can expose the steel braids and cause an electrical short ([See Form #1570](#)).

10.3 Hydraulic Pump Box (DC)

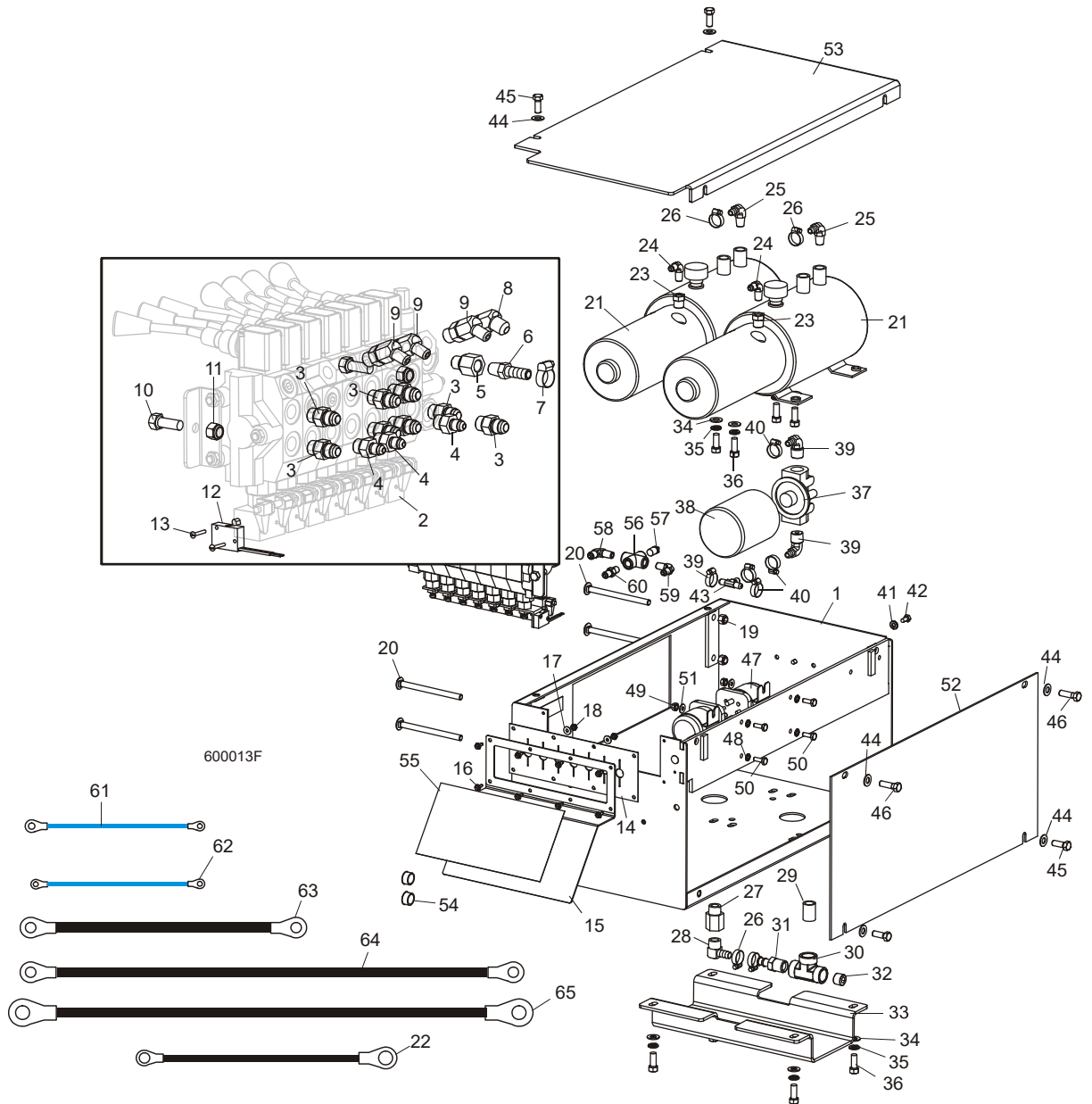

REF	DESCRIPTION (◆ Indicates Parts Available In Assemblies Only)	PART #	QTY.
	BOX ASSEMBLY, LT60/70 DC HYDRAULIC CONTROL	017649	1
1	Box Weldment, Hydraulic Control	034383	1
	Valve Assembly, 7-Section Hydraulic	034533	1
2	Valve, 7-Section Hydraulic	034451	1
3	Fitting, 3/8" O-Ring x 3/8" JIC	014687	8
4	Fitting, 1/4" JIC x 3/8" O-Ring	P26284	3

5	Fitting, #6 SAE x 1/4" NPT Female	014686	1	
6	Fitting, 1/4" NPT x 3/8" Hose Barb	014685	1	
7	Clamp, 11/16" Hose	P12739	1	
8	Fitting, #6 SAE 45° Elbow	015489	1	
9	Fitting, #4 SAE x #6 SAE 45° Elbow	015488	3	
10	Bolt, 3/8-16 x 1" Hex Head	F05007-7	2	
11	Nut, 3/8-16 Hex Nylon Lock	F05010-10	2	
12	Switch, Hydraulic Valve Lever	024198	1	
13	Screw, #4-40 x 3/4" Slotted Head	F05004-13	2	
14	Seal, 7-Handle Valve Rubber	034202	1	
15	Plate, 7-Handle Decal	033999	1	
16	Screw, #10-24 x 1/2" Self-Tapping	F05015-7	8	
17	Washer, #10 SAE Flat	F05011-18	2	
18	Nut, #10-24 Hex Self-Locking	F05010-14	2	
19	Nut, 3/8-16 Hex Nylon Lock	F05010-10	4	
20	Bolt, 3/8-16 x 5" Carriage Head	F05007-113	4	
	Pump Assembly, LT60/70 DC Hydraulic	034534	1	
21	Pump Kit, Hydraulic w/Motor	061764 ¹	2	
	Pump, Hydraulic Replacement Monarch Model #12070	016199	1	
	Motor Kit, Hydraulic Replacement	052807	1	
	Motor, 12 VDC Hydraulic Pump #08714 (Iskra)	038683 ²	1	◆
	Brush Kit, 4-Valve Hydraulic Pump Motor #08658-I (Iskra)	038682 ²	1	
	Brush Kit, 4-Valve Hydraulic Pump Motor #08658 (Bosch)	P09585 ²	1	◆
	Bearing, Base Motor #02318	P12513	1	
22	Wire Assembly, Motor Brush Ground	052806 ³	1	
	Cap, Hydraulic Pump Vented Fill #03171	P12817	1	
	O-Ring, Hydraulic Pump/Reservoir #02352	P10198	1	
	Seal, Hydraulic Pump/Motor #02330	P10315	1	
23	Fitting, 3/8" NPT x 1/4" NPT Reducer	015490	2	
24	Fitting, 1/4" NPT x 1/4" JIC Elbow	P09142	2	
25	Fitting, 3/8" NPT x 3/8" Hose Barb Elbow	P12708	2	
26	Clamp, 11/16" Hose	P12739	4	
27	Fitting, 1/2" NPT x 1/2" NPT Adapter	015995	1	
28	Fitting, 1/2" NPT x 1/2" Hose Barb Elbow	015997	1	
29	Fitting, 1/2" NPT Close Brass Nipple	016795	1	
30	Fitting, 1/2" NPT Female Tee	016793	1	
31	Fitting, 1/2" NPT Male x 1/2" Hose Barb	016794	1	
32	Fitting, 1/2" NPT Pipe Plug	P26258	1	
33	Guard, Crossover Hose	015992	1	
34	Washer, 3/8" SAE Flat	F05011-3	8	
35	Washer, 3/8" Split Lock	F05011-4	8	
36	Bolt, 3/8-16 x 1" Hex Head	F05007-7	8	

10

Hydraulic System Hydraulic Pump Box (DC)

37	Manifold, Hydraulic Filter w/Cartridge	P22683	1	
38	Filter, S28 Hydraulic Cartridge	P20301	1	
39	Fitting, 1/2" NPT x 3/8" Hose Barb Elbow	P12707	2	
40	Clamp, 11/16" Hose Clamp	P12739	2	
41	Washer, 1/4" Split Lock	F05011-14	2	
42	Bolt, 1/4-20 x 1/2" Hex Head	F05005-15	2	
43	Fitting, 3/8" Hose Barb Tee	015485	1	
44	Washer, 3/8" SAE Flat	F05011-3	6	
45	Bolt, 3/8-16 x 1" Hex Head Grade 5	F05007-87	4	
46	Bolt, 3/8-16 x 1 1/4" Hex Head	F05007-2	2	
47	Solenoid Kit, 200A 12V SPST Hydraulic Motor	016371	2	
	Solenoid, 200A 12V SPST Cont. Duty	015470	1	◆
	Diode Assembly, Solenoid Coil Chassis Gnd	015426 ⁴	1	
48	Washer, 1/4" External Lock	F05011-37	4	
49	Nut, 1/4-20 Hex Self-Locking	F05010-9	4	
50	Bolt, 1/4-20 x 3/4" Hex Head Full Thread	F05005-1	4	
51	Washer, 1/4" SAE Flat	F05011-11	4	
52	Plate, Hydraulic Control Box Side	015227	1	
53	Plate, Hydraulic Control Box Top	015228	1	
54	Grommet, 5/8" Wire	P04137	2	
55	Decal, Hydraulic Control Lever	017669	1	
56	Fitting, 1/4" NPT Cross	P22311	1	
57	Gauge, 5000 PSI Hydraulic Pressure	P10052	1	
58	Fitting, 3/8" JIC x 1/4" NPT Elbow	015490 ⁵	1	
59	Fitting, 1/4" NPT x 1/4" JIC Male Elbow	P09142	1	
60	Fitting, 1/4" NPT x 1/4" JIC Male	P09143	1	
	Hose, 3/8" x 6 1/2" Hydraulic w/Fittings	036303 ⁵	1	
	Hose, 1/4" x 15" Hydraulic w/Fittings	036292	2	
61	WIRE ASSEMBLY, 14 GA X 4" #10 & 5/16" RING TERMINALS	036315	2	
62	WIRE ASSEMBLY, 14 GA X 4" #10 RING TERMINALS	036314	1	
63	CABLE ASSEMBLY, 1 GA X 6" HYDRAULIC PUMP TO SOLENOID	036311	1	
64	CABLE ASSEMBLY, 1 GA X 16" HYDRAULIC PUMP TO SOLENOID	036310	1	
65	CABLE ASSEMBLY, 1 GA X 16" HYDRAULIC PUMP GROUND	036312	2	
	WASHER, 3/8" STAR EXTERNAL	F05011-36	3	

¹ Pump Kit 061764 replaces Pump P12701 1/09. Kit includes P12701 plus Brush Ground Wire Kit 052805 to insure adequate ground connection.

² Bosch motor P09955 replaced by vendor with Iskra motor 1/06. Brush kit P09585 no longer available to service Bosch motor. Replace motor using kit 05280. Use Brush Kit 038682 to service Iskra motor.

³ Brush Ground Wire 052806 added Rev. A7.06 to improve ground connection. Kit 052805 to be supplied to all customers who purchased sawmills with Iskra pump motors after 1/06. Kit includes wire, hardware and instructions (One kit required per pump).

⁴ Diode Assembly 015426 added to prevent damage to hydraulic microswitch (Rev. A3.03).

⁵ Elbow Fitting 015490 replaces Straight Fitting 015560 and hose 036303 shortened from 8" to 6 1/2" to improve hose routing (Rev. A4.01).

10.4 Hydraulic Pump Box (230/460V AC)

LT60HD/70HD

Rev. A7.09 - B3.01

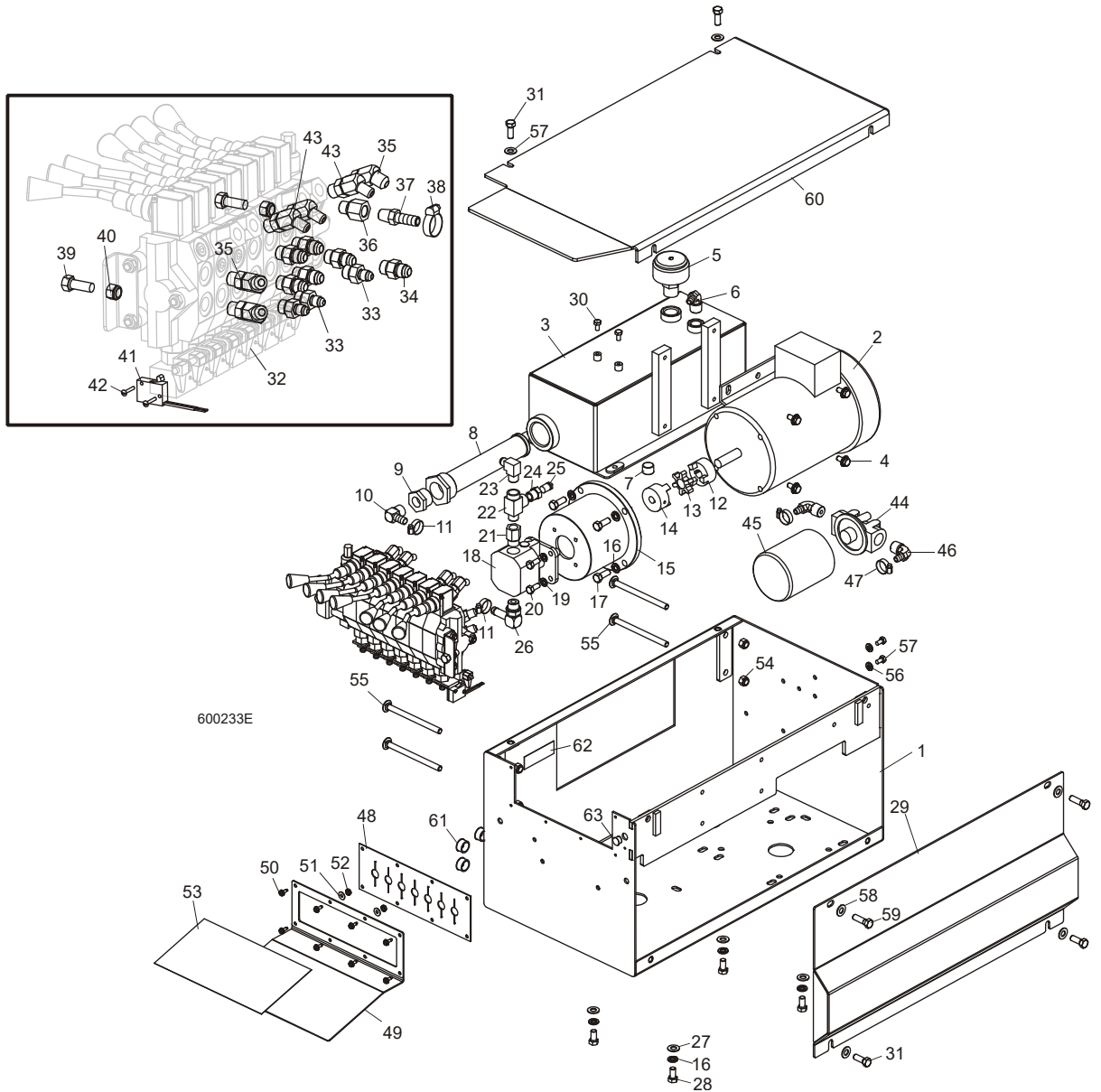

REF	DESCRIPTION (◆ Indicates Parts Available In Assemblies Only)	PART #	QTY.
	BOX ASSEMBLY, LT60/70 230/460V AC HYDRAULIC CONTROL	017677	1
1	Box Weldment, Hydraulic Control	034383	1
	Pump Assembly, 230/460V AC	038963	1
2	Motor, 3HP 230/460V 56C 3450RPM	055312	1
3	Tank Weldment, LT70 Hydraulic	054825	1
4	Bolt, 5/16-18 x 3/4" Hex Head w/Flat & Lock Washer	F05006-101	4

10

Hydraulic System

Hydraulic Pump Box (230/460V AC)

5	Cap, Hydraulic Breather/Filter	P20212	1	
6	Fitting, 1/2" NPT x 3/8" Hose Barb Elbow	P12707	1	
7	Fitting, 1/2" NPT Pipe Plug	P26258	1	
8	Filter, Hydraulic Tank Suction	P20210	1	
9	Fitting, 1/2" NPT x 1" NPT Bushing	P20239	1	
10	Fitting, 1/2" NPT x 1/2" Hose Barb Elbow	015997	1	
11	Clamp, 11/16" Hose	P12739	2	
12	Coupling Body, L075 x 5/8"	038951	1	
13	Coupling Spider, L075	P20218	1	
14	Coupling Body, L075 x 1/2"	P20217	1	
15	Adaptor, Hydraulic Motor to Pump	P20215	1	
16	Washer, 3/8" Split Lock	F05011-4	8	
17	Bolt, 3/8-16 x 1" Hex Head Grade 5	F05007-87	4	
18	Pump, Hydraulic	P20213	1	
19	Washer, 5/16" Split Lock	F05011-13	4	
20	Bolt, 5/16-18 x 3/4" Hex Head Grade 5	F05006-102	4	
21	Fitting, #8 SAE x 3/8" NPT Female	P12706	1	
22	Fitting, 3/8" NPT Male Run Tee	016822	1	
23	Fitting, 3/8" NPT x 3/8" JIC Elbow	016820	1	
24	Fitting, 3/8" NPT x 1/4" NPT Reducer	015490	1	
25	Gauge, 5000 PSI Hydraulic	P10052	1	
26	Fitting, #8 SAE x 1/2" Hose Barb Elbow	038949	1	
27	Washer, 3/8" SAE Flat	F05011-3	4	
28	Bolt, 3/8-16 x 3/4" Hex Head	F05007-27	4	
29	Plate Weldment, Hydraulic Control Box Side	038966	1	
	Hose, 3/8" x 24" Hydraulic	003260	1	
	Hose, 1/2" ID Low Pressure Hydraulic	R02133	.67 ft.	
	Hose, 3/8" ID Low Pressure Hydraulic	R01892-1	3.5 ft.	
30	Bolt, 3/8-16 x 1" Hex Head Grade 5	F05007-87	4	
	Valve Assembly, 7-Section AC Hydraulic	017684	1	
31	Valve, 7-Section Hydraulic	034451	1	
32	Fitting, 1/4" JIC x 3/8" O-Ring	P26284	3	
33	Fitting, 3/8" O-Ring x 3/8" JIC	014687 ¹	6	
34	Fitting, #6 SAE 45° Elbow	015489 ¹	3	
35	Fitting, #6 SAE x 1/4" NPT Female	014686	1	
36	Fitting, 1/4" NPT x 3/8" Hose Barb	014685	1	
37	Clamp, 11/16" Hose	P12739	1	
38	Bolt, 3/8-16 x 1" Hex Head	F05007-7	2	
39	Nut, 3/8-16 Hex Nylon Lock	F05010-10	2	
40	Switch, Hydraulic Valve Lever	024198	1	
41	Screw, #4-40 x 3/4" Slotted Head	F05004-13	2	
42	Fitting, #4 SAE x #6 SAE 45° Elbow	015488	3	
43	Manifold, Hydraulic Filter w/Cartridge	P22683	1	

Hydraulic System

Hydraulic Pump Box (230/460V AC)

10

44	Filter, S28 Hydraulic Cartridge	P20301	1	
45	Fitting, 1/2" NPT x 3/8" Hose Barb Elbow	P12707	2	
46	Clamp, 11/16" Hose	P12739	2	
47	Seal, 7-Handle Valve Rubber	034202	1	
48	Plate, 7-Handle Decal	017771	1	
49	Screw, #10-24 x 1/2" Self-Tapping	F05015-7	8	
50	Washer, #10 SAE Flat	F05011-18	2	
51	Nut, #10-24 Hex Self-Locking	F05010-14	2	
52	Decal, Hydraulic Control Lever	017669	1	
53	Nut, 3/8-16 Hex Nylon Lock	F05010-10	4	
54	Bolt, 3/8-16 x 5" Carriage Head	F05007-113	4	
55	Washer, 1/4" Split Lock	F05011-14	2	
56	Bolt, 1/4-20 x 1/2" Hex Head	F05005-15	2	
57	Washer, 3/8" SAE Flat	F05011-3	6	
58	Bolt, 3/8-16 x 1 1/4" Hex Head	F05007-2	2	
59	Plate, Hydraulic Control Box Top	015228	1	
60	Grommet, 5/8" Wire	P04137	3	
61	Decal, Hyd. Fluid Replacement Info	S12825	1	
62	Plug, 1/2" Hole	036244	1	

¹ One straight fitting 014687 replaces elbow fitting 015489 at inlet/outlet location. Two elbow fittings 015489 replace straight fittings 014687 at loader bank location. Fittings changed to eliminate interference with pressure gauge and hose bundle (11/07).

10.5 Hydraulic Pump Box (575V AC)

LT60HD/70HD

Rev. A7.09 - B3.01

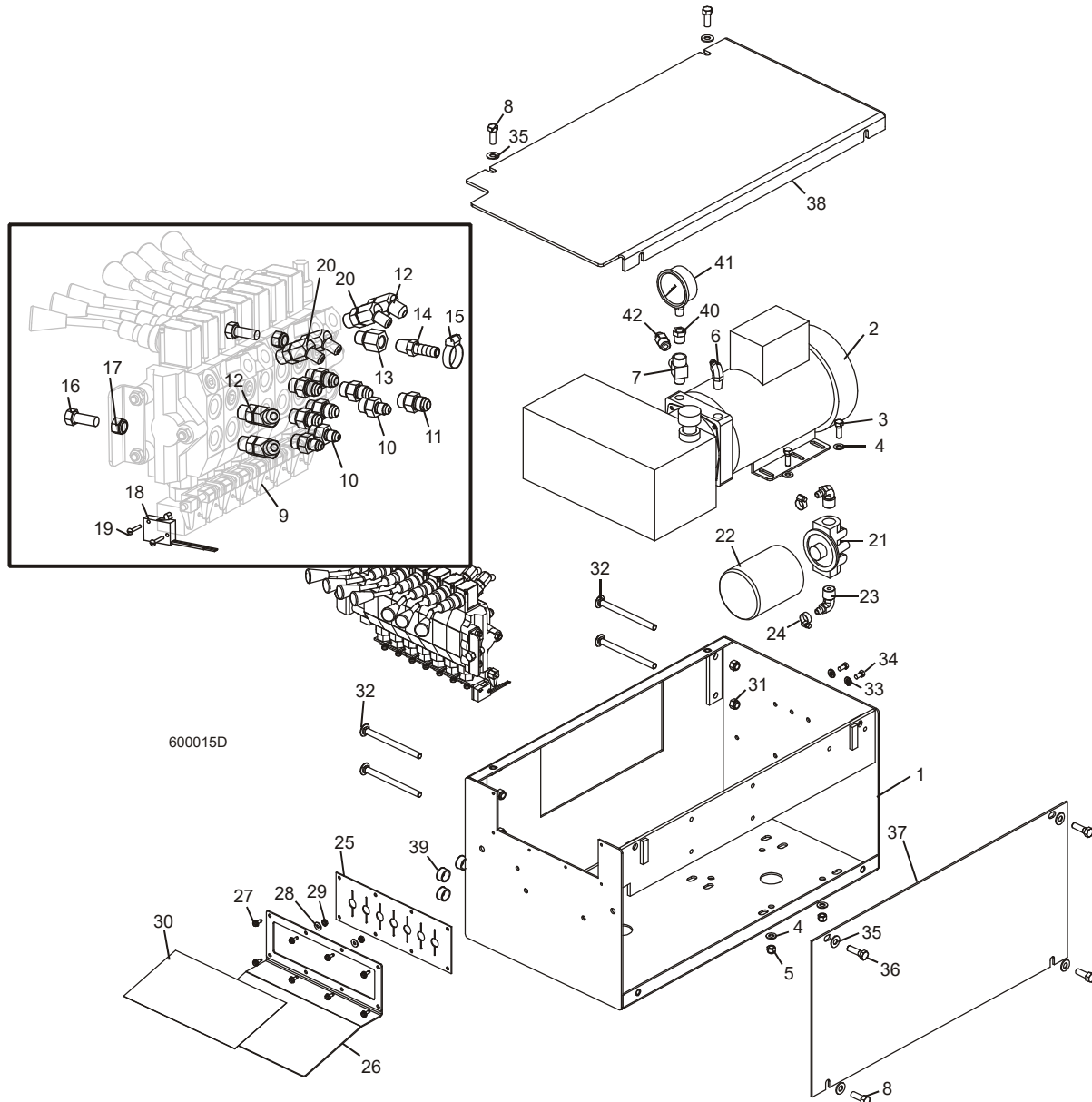

REF	DESCRIPTION (◆ Indicates Parts Available In Assemblies Only)	PART #	QTY.
	BOX ASSEMBLY, LT60/70 575V AC HYDRAULIC CONTROL	036438	1
1	Box Weldment, Hydraulic Control	034383	1
2	Pump, Hydraulic 575V AC w/Tank	034794	1
3	Bolt, 5/16-18 x 1" Hex Head	F05006-1	4
4	Washer, 5/16" SAE Flat	F05011-17	8
5	Nut, 5/16-18 Nylon Lock	F05010-58	4

6	Fitting, 3/8" NPT x 3/8" Hose Barb Elbow	P12708	1	
7	Fitting, 3/8" NPT Male Run Tee	016822	1	
8	Bolt, 3/8-16 x 1" Hex Head Grade 5	F05007-87	4	
	Valve Assembly, 7-Section AC Hydraulic	017684	1	
9	Valve, 7-Section Hydraulic	034451	1	
10	Fitting, 1/4" JIC x 3/8" O-Ring	P26284	3	
11	Fitting, 3/8" O-Ring x 3/8" JIC	014687 ¹	6	
12	Fitting, #6 SAE 45° Elbow	015489 ¹	3	
13	Fitting, #6 SAE x 1/4" NPT Female	014686	1	
14	Fitting, 1/4" NPT x 3/8" Hose Barb	014685	1	
15	Clamp, 11/16" Hose	P12739	1	
16	Bolt, 3/8-16 x 1" Hex Head	F05007-7	2	
17	Nut, 3/8-16 Hex Nylon Lock	F05010-10	2	
18	Switch, Hydraulic Valve Lever	024198	1	
19	Screw, #4-40 x 3/4" Slotted Head	F05004-13	2	
20	Fitting, #4 SAE x #6 SAE 45° Elbow	015488	3	
21	Manifold, Hydraulic Filter w/Cartridge	P22683	1	
22	Filter, S28 Hydraulic Cartridge	P20301	1	
23	Fitting, 1/2" NPT x 3/8" Hose Barb Elbow	P12707	2	
24	Clamp, 11/16" Hose Clamp	P12739	2	
25	Seal, 7-Handle Valve Rubber	034202	1	
26	Plate, 7-Handle Decal	017771	1	
27	Screw, #10-24 x 1/2" Self-Tapping	F05015-7	8	
28	Washer, #10 SAE Flat	F05011-18	2	
29	Nut, #10-24 Hex Self-Locking	F05010-14	2	
30	Decal, Hydraulic Control Lever	017669	1	
31	Nut, 3/8-16 Hex Nylon Lock	F05010-10	4	
32	Bolt, 3/8-16 x 5" Carriage Head	F05007-113	4	
33	Washer, 1/4" Split Lock	F05011-14	2	
34	Bolt, 1/4-20 x 1/2" Hex Head	F05005-15	2	
35	Washer, 3/8" SAE Flat	F05011-3	6	
36	Bolt, 3/8-16 x 1 1/4" Hex Head	F05007-2	2	
37	Plate, Hydraulic Control Box Side	015227	1	
38	Plate, Hydraulic Control Box Top	015228	1	
39	Grommet, 5/8" Wire	P04137	3	
40	Fitting, 3/8" NPT x 1/4" NPT Reducer	015490	1	
41	Gauge, 5000 PSI Hydraulic	P10052	1	
42	Fitting, 3/8" NPT x 3/8" JIC Elbow	016819	1	

¹ One straight fitting 014687 replaces elbow fitting 015489 at inlet/outlet location. Two elbow fittings 015489 replace straight fittings 014687 at loader bank location. Fittings changed to eliminate interference with pressure gauge and hose bundle (11/07).

10.6 Hydraulic Pump Box (AC)

LT60HD/70HD

Rev. A3.01 - A7.08

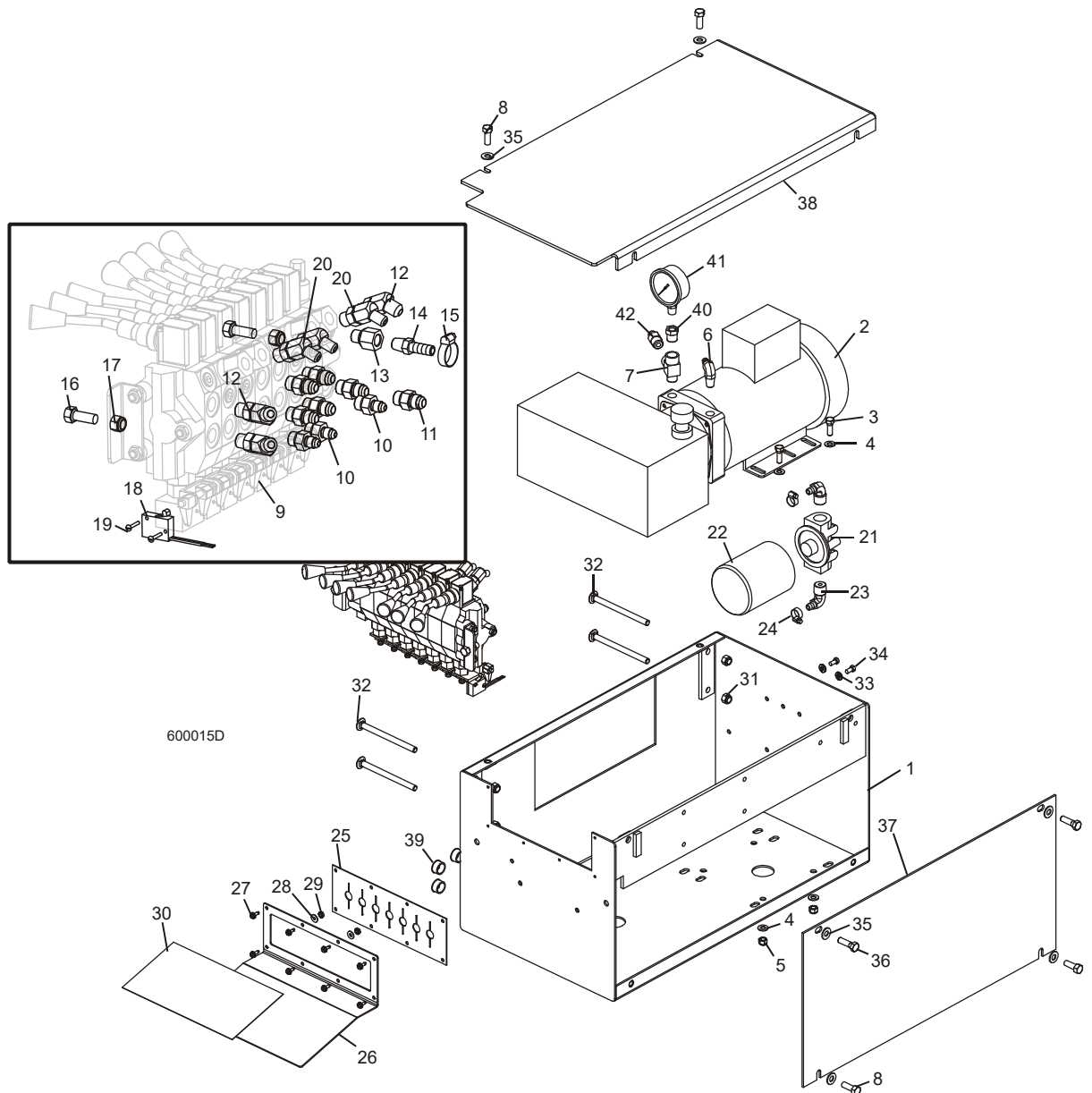

REF	DESCRIPTION (◆ Indicates Parts Available In Assemblies Only)	PART #	QTY.
	BOX ASSEMBLY, LT60/70 230/460V AC HYDRAULIC CONTROL	017677	1
	BOX ASSEMBLY, LT60/70 575V AC HYDRAULIC CONTROL	036438	1
1	Box Weldment, Hydraulic Control	034383	1

2	Pump, Hydraulic 230/460V AC w/Tank	034457 ¹	1	◆
	Pump, Hydraulic 575V AC w/Tank	034794	1	
3	Bolt, 5/16-18 x 1" Hex Head	F05006-1	4	
4	Washer, 5/16" SAE Flat	F05011-17	8	
5	Nut, 5/16-18 Nylon Lock	F05010-58	4	
6	Fitting, 3/8" NPT x 3/8" Hose Barb Elbow	P12708	1	
7	Fitting, 3/8" NPT Male Run Tee	016822	1	
8	Bolt, 3/8-16 x 1" Hex Head Grade 5	F05007-87	4	
	Valve Assembly, 7-Section AC Hydraulic	017684	1	
9	Valve, 7-Section Hydraulic	034451	1	
10	Fitting, 1/4" JIC x 3/8" O-Ring	P26284	3	
11	Fitting, 3/8" O-Ring x 3/8" JIC	014687 ²	6	
12	Fitting, #6 SAE 45° Elbow	015489 ²	3	
13	Fitting, #6 SAE x 1/4" NPT Female	014686	1	
14	Fitting, 1/4" NPT x 3/8" Hose Barb	014685	1	
15	Clamp, 11/16" Hose	P12739	1	
16	Bolt, 3/8-16 x 1" Hex Head	F05007-7	2	
17	Nut, 3/8-16 Hex Nylon Lock	F05010-10	2	
18	Switch, Hydraulic Valve Lever	024198	1	
19	Screw, #4-40 x 3/4" Slotted Head	F05004-13	2	
20	Fitting, #4 SAE x #6 SAE 45° Elbow	015488	3	
21	Manifold, Hydraulic Filter w/Cartridge	P22683	1	
22	Filter, S28 Hydraulic Cartridge	P20301	1	
23	Fitting, 1/2" NPT x 3/8" Hose Barb Elbow	P12707	2	
24	Clamp, 11/16" Hose Clamp	P12739	2	
25	Seal, 7-Handle Valve Rubber	034202	1	
26	Plate, 7-Handle Decal	017771	1	
27	Screw, #10-24 x 1/2" Self-Tapping	F05015-7	8	
28	Washer, #10 SAE Flat	F05011-18	2	
29	Nut, #10-24 Hex Self-Locking	F05010-14	2	
30	Decal, Hydraulic Control Lever	017669	1	
31	Nut, 3/8-16 Hex Nylon Lock	F05010-10	4	
32	Bolt, 3/8-16 x 5" Carriage Head	F05007-113	4	
33	Washer, 1/4" Split Lock	F05011-14	2	
34	Bolt, 1/4-20 x 1/2" Hex Head	F05005-15	2	
35	Washer, 3/8" SAE Flat	F05011-3	6	
36	Bolt, 3/8-16 x 1 1/4" Hex Head	F05007-2	2	
37	Plate, Hydraulic Control Box Side	015227	1	
38	Plate, Hydraulic Control Box Top	015228	1	
39	Grommet, 5/8" Wire	P04137	3	
40	Fitting, 3/8" NPT x 1/4" NPT Reducer	015490	1	
41	Gauge, 5000 PSI Hydraulic	P10052	1	
42	Fitting, 3/8" NPT x 3/8" JIC Elbow	016819	1	

10

Hydraulic System

Hydraulic Pump Box (AC)

- ¹ Motor/Pump/Tank Assembly 034457 discontinued by vendor. Use assembly 038963 for service ([See Section 10.4](#)). Replacement requires modification or replacement of pump box 034383 with appropriate mounting holes and replacement of side cover 015227 with side cover weldment 038966 ([See Form #1501](#)).
- ² One straight fitting 014687 replaces elbow fitting 015489 at inlet/outlet location. Two elbow fittings 015489 replace straight fittings 014687 at loader bank location. Fittings changed to eliminate interference with pressure gauge and hose bundle (11/07).

10.7 Hydraulic Control Box (230/460V AC)

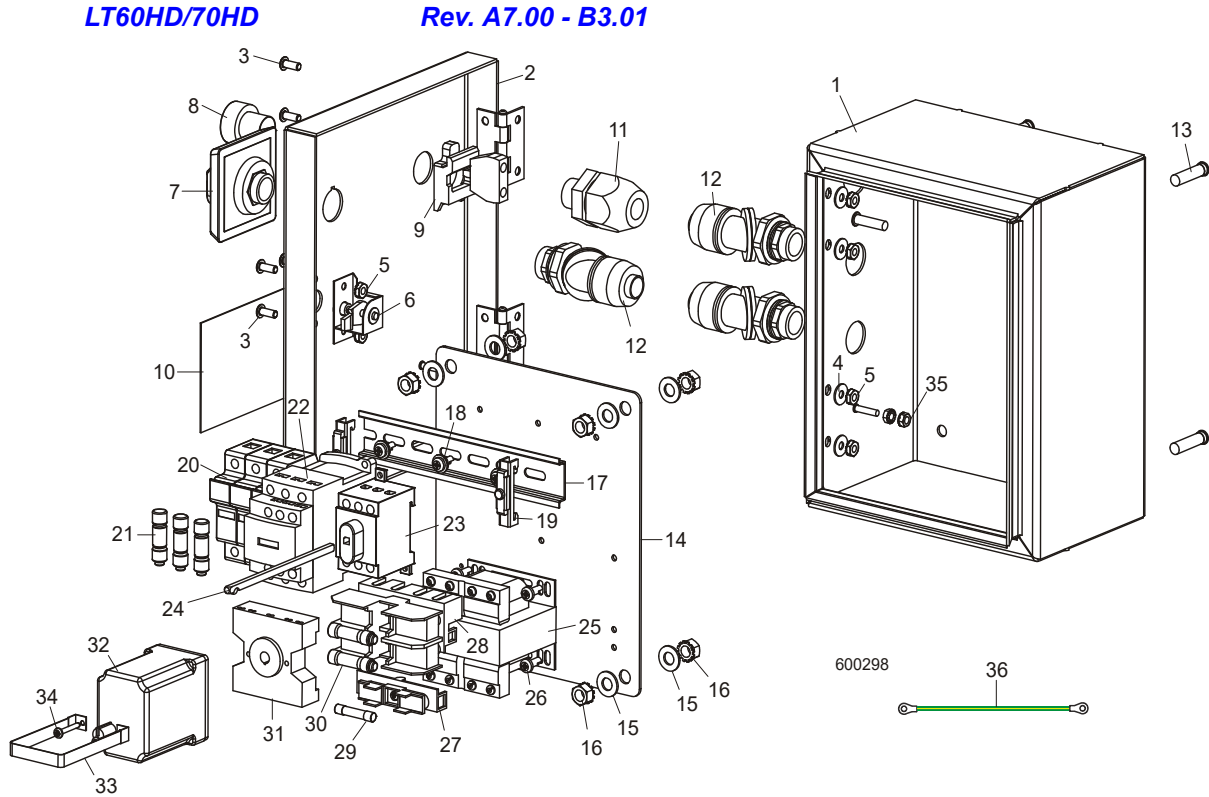

REF	DESCRIPTION (◆ Indicates Parts Available In Assemblies Only)	PART #	QTY.
	CONTROL ASSEMBLY, LT70 E25-L HYDRAULIC	052384	1
	CONTROL ASSEMBLY, LT70 E25-H HYDRAULIC	052385	1
1	Box Weldment, Hydraulic AC Control	050302	1
2	Door Weldment, Hydraulic AC Control Box	052379	1
3	Screw, #10-24 x 1/2" Socket Button Head Stainless	F05004-196	6
4	Washer, #10 SAE Flat	F05011-18	4
5	Nut, #10-24 Self-Locking Hex	F05010-14	6
6	Latch, Door	051978	1
7	Switch, Red/Yellow Disconnect 6mm	050883-1 ¹	1
8	Switch Head, Green Guarded	050152	1
9	Switch Body, 1NO 22mm ZB4	025242	1
10	Decal, Electrical Hazard 2 Places	051948	1
11	Connector, 1/2" Liquid-Tite Straight	E22721	1
12	Connector, 1/2" Liquid-Tite Swivel	051750	3
13	Stud, 5/16-18 x 1 1/4" Type CH Clinch	F05006-113	4
14	Plate, LT70 AC Hydraulic Control Insert	052377	1
15	Washer, 5/16" SAE Flat	F05011-17	8
16	Nut, 5/16-18 Self-Locking Hex	F05010-20	8

10

Hydraulic System

Hydraulic Control Box (230/460V AC)

17	Rail, 35mm x 7.5mm x 6.875" Steel DIN	024474-6_875	1	
18	Screw, #10-24 x 1/2" Phillips Head	F05004-186	3	
19	Clamp, Plastic DIN Rail	E22707	2	
20	Fuse Holder, 3P Class CC Finger Safe	052380	1	
21	Fuse, 15A 600V Class CC Delay (E25-L)	052513	3	
	Fuse, 8A 600V Class CC Delay (E25-H)	052381	3	
22	Contactor, 18A 3P 24VAC Coil (E25-L)	052689	1	
	Contactor, 9A 3P 24VAC Coil (E25-H)	025290	1	
23	Disconnect, 40A 3P Non-Fused 6mm	050903-1 ¹	1	
24	Shaft, Disconnect Extension 6mm	050882-1 ¹	1	
25	Transformer, 240/480-24VAC 50VA	053009	1	
26	Screw, #10-24 x 1/2" Phillips Pan Head Type 23	F05015-17	4	
27	Fuse Block, T50 Transformer Secondary	053011	1	
28	Fuse Block, T50 Transformer Primary	053010	1	
29	Fuse, 3A 250V 1/4x1 1/4 MDL Delay	025297	1	
30	Fuse, 4/10A 600V KLDR Class CC	P03151	2	
31	Socket, 11-Pin Relay	E22700	1	
32	Relay, .1-10s 24VDC Coil Timer Off Delay	052383	1	
33	Strap, Timer Relay Retaining	050967	1	
34	Screw, M8 x 1.25 x 1 Hex Head Full Thread	F05004-42	2	
35	Nut, #8-32 Self-Locking Hex	F05010-41	2	
36	Wire Assembly, 10" Ground	025187	1	

¹ 5mm Disconnect Shaft OXS5X120 replaced by vendor with 6mm shaft OXS6X120 (2/10). Replacement of any disconnect component requires replacement of disconnect, shaft and operator handle (050903-1, 050883-1 & 050882-1).

10.8 Hydraulic Control Box (230/460V AC)

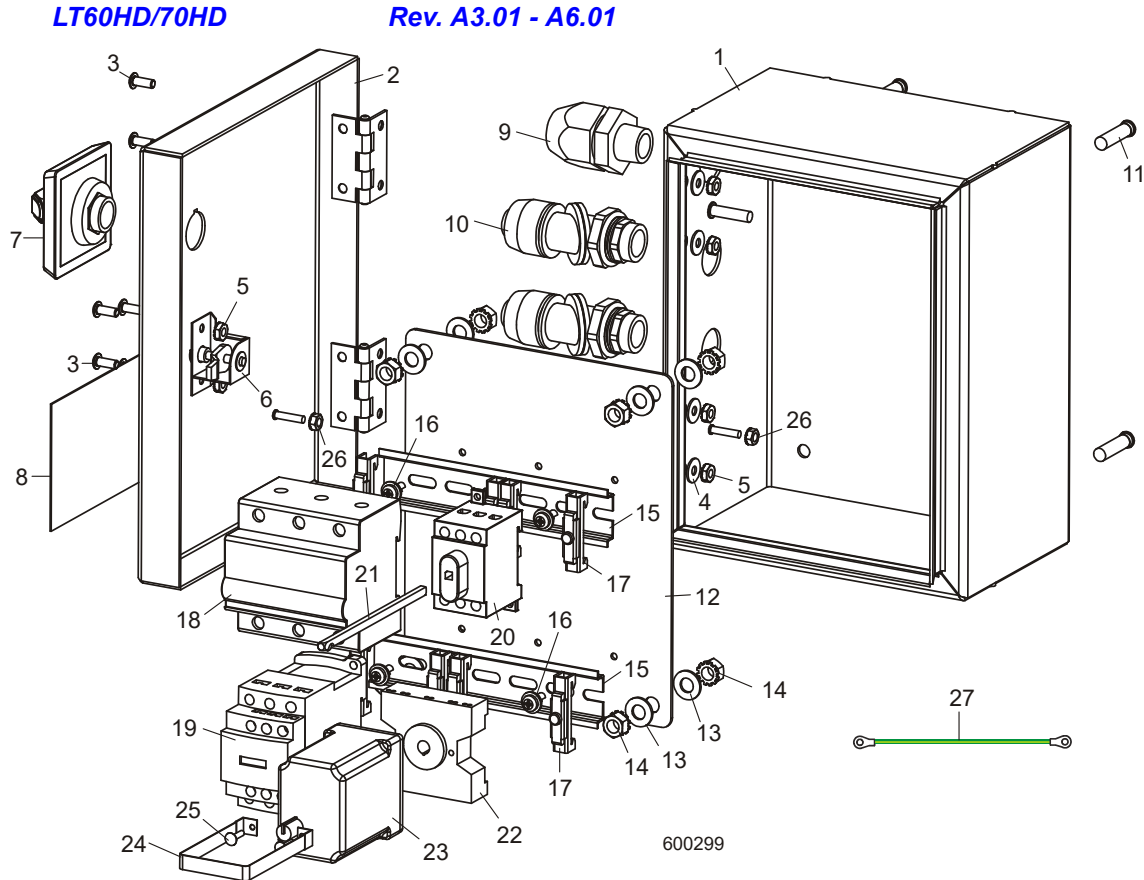

REF	DESCRIPTION (◆ Indicates Parts Available In Assemblies Only)	PART #	QTY.
	CONTROL ASSEMBLY, LT70 E25-L HYDRAULIC	050275	1
	CONTROL ASSEMBLY, LT70 E25-H HYDRAULIC	050276	1
1	Box Weldment, Hydraulic AC Control	050302	1
2	Door Weldment, Hydraulic AC Control Box	050307	1
3	Screw, #10-24 x 1/2" Socket Button Head Stainless	F05004-196	6
4	Washer, #10 SAE Flat	F05011-18	4
5	Nut, #10-24 Self-Locking Hex	F05010-14	6
6	Latch, Door	051978 ¹	1
7	Switch, Red/Yellow Disconnect 6mm	050883-1 ²	1
8	Decal, Electrical Hazard 2 Places	051948 ³	1
9	Connector, 1/2" Liquid-Tite Straight	E22721	1
10	Connector, 1/2" Liquid-Tite Swivel	051750 ⁴	2
11	Stud, 5/16-18 x 1 1/4" Type CH Clinch	F05006-113	4
12	Plate, LT70 AC Hydraulic Control Insert	050306	1
13	Washer, 5/16" SAE Flat	F05011-17	8

10

Hydraulic System

Hydraulic Control Box (230/460V AC)

14	Nut, 5/16-18 Self-Locking Hex	F05010-20	8	
15	Rail, 35mm x 7.5mm x 6" Steel DIN	024474-6	2	
16	Screw, #10-24 x 1/2" Phillips Head	F05004-186	4	
17	Clamp, Plastic DIN Rail	E22707	8	
18	Breaker, 16A 3P Curve D C60N (E25-L)	024904	1	
	Breaker, 8A 3P cureve D C60N (E25-H)	050335	1	
19	Contactor, 18A 3P 12VDC Coil	050332	1	
20	Disconnect, 40A 3P Non-Fused 6mm	050903-1 ²	1	
21	Shaft, Disconnect Extension 6mm	050882-1 ²	1	
22	Socket, 11-Pin Relay	E22700	1	
23	Relay, .1-10s 12VDC Coil Timer Off Delay	050314	1	
24	Strap, Timer Relay Retaining	050967	1	
25	Rivet, 1/8" x 1/2" STI SS48D Pop	F04203-5	2	
26	Nut, #8-32 Self-Locking Hex	F05010-41	2	
27	Wire Assembly, 10" Ground	025187	1	

¹ Replaces Latch 050259 Rev. A5.01.

² 5mm Disconnect Shaft OXS5X120 replaced by vendor with 6mm shaft OXS6X120 (2/10). Replacement of any disconnect component requires replacement of disconnect, shaft and operator handle (050903-1, 050883-1 & 050882-1).

³ Decal Added Rev. A5.01.

⁴ Swivel Connector 051750 replaces Elbow Fitting E22722 4/04.

10.9 Hydraulic Control Box (575V AC)

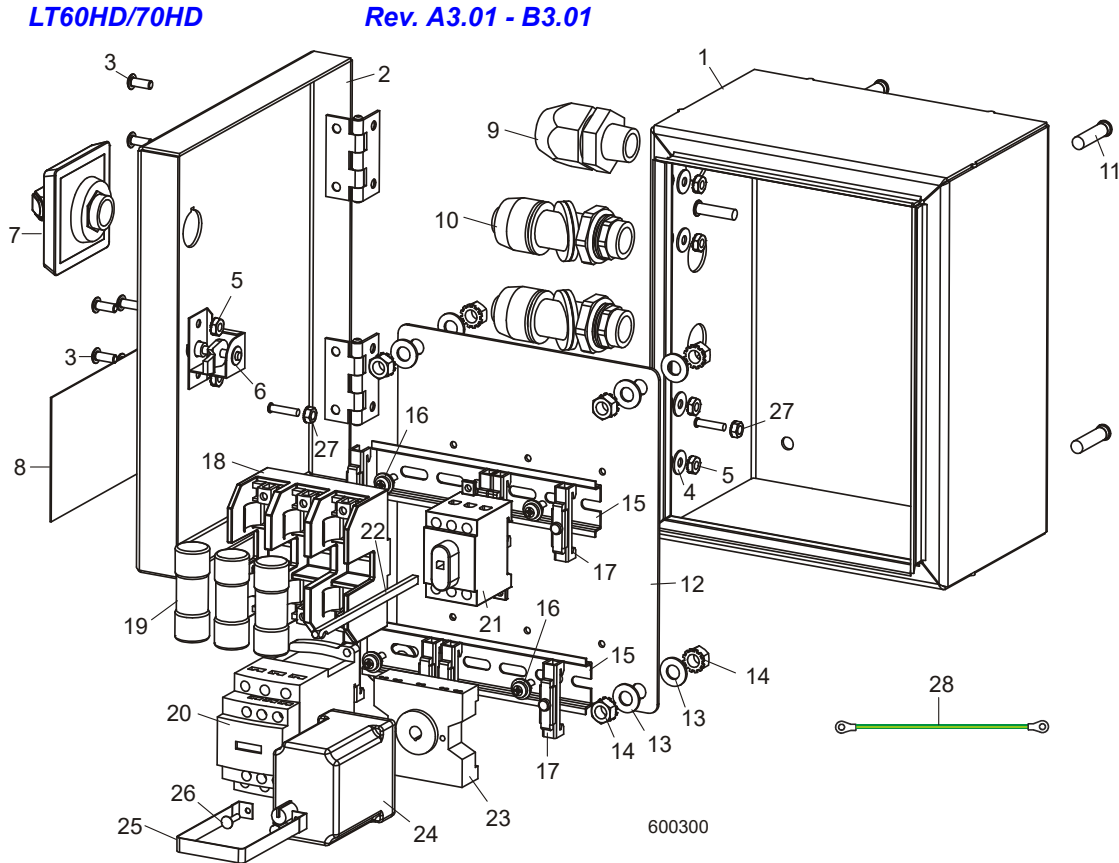

REF	DESCRIPTION (◆ Indicates Parts Available In Assemblies Only)	PART #	QTY.
	CONTROL ASSEMBLY, LT70 E25-C HYDRAULIC	050277	1
1	Box Weldment, Hydraulic AC Control	050302	1
2	Door Weldment, Hydraulic AC Control Box	050307	1
3	Screw, #10-24 x 1/2" Socket Button Head Stainless	F05004-196	6
4	Washer, #10 SAE Flat	F05011-18	4
5	Nut, #10-24 Self-Locking Hex	F05010-14	6
6	Latch, Door	051978 ¹	1
7	Switch, Red/Yellow Disconnect 6mm	050883-1 ²	1
8	Decal, Electrical Hazard 2 Places	051948 ³	1
9	Connector, 1/2" Liquid-Tite Straight	E22721	1
10	Connector, 1/2" Liquid-Tite Swivel	051750 ⁴	2
11	Stud, 5/16-18 x 1 1/4" Type CH Clinch	F05006-113	4
12	Plate, LT70 AC Hydraulic Control Insert	050306	1
13	Washer, 5/16" SAE Flat	F05011-17	8
14	Nut, 5/16-18 Self-Locking Hex	F05010-20	8
15	Rail, 35mm x 7.5mm x 6" Steel DIN	024474-6	2

10**Hydraulic System***Hydraulic Control Box (575V AC)*

16	Screw, #10-24 x 1/2" Phillips Head	F05004-186	4	
17	Clamp, Plastic DIN Rail	E22707	8	
18	Fuse Block, 30A 600V 3P Class J	050345	1	
19	Fuse, 8A 600V Class J	E22715	3	
20	Contactor, 18A 3P 12VDC Coil	050332	1	
21	Disconnect, 40A 3P Non-Fused 6mm	050903-1 ²	1	
22	Shaft, Disconnect Extension 6mm	050882-1 ²	1	
23	Socket, 11-Pin Relay	E22700	1	
24	Relay, .1-10s 12VDC Coil Timer Off Delay	050314	1	
25	Strap, Timer Relay Retaining	050967	1	
26	Rivet, 1/8" x 1/2" STI SS48D Pop	F04203-5	2	
27	Nut, #8-32 Self-Locking Hex	F05010-41	2	
28	Wire Assembly, 10" Ground	025187	1	

¹ Replaces Latch 050259 Rev. A5.01.

² 5mm Disconnect Shaft OXS5X120 replaced by vendor with 6mm shaft OXS6X120 (2/10). Replacement of any disconnect component requires replacement of disconnect, shaft and operator handle (050903-1, 050883-1 & 050882-1).

³ Decal Added Rev. A5.01.

⁴ Swivel Connector 051750 replaces Elbow Fitting E22722 4/04.

10.10 Hydraulic Power Supply Strip (DC Only)

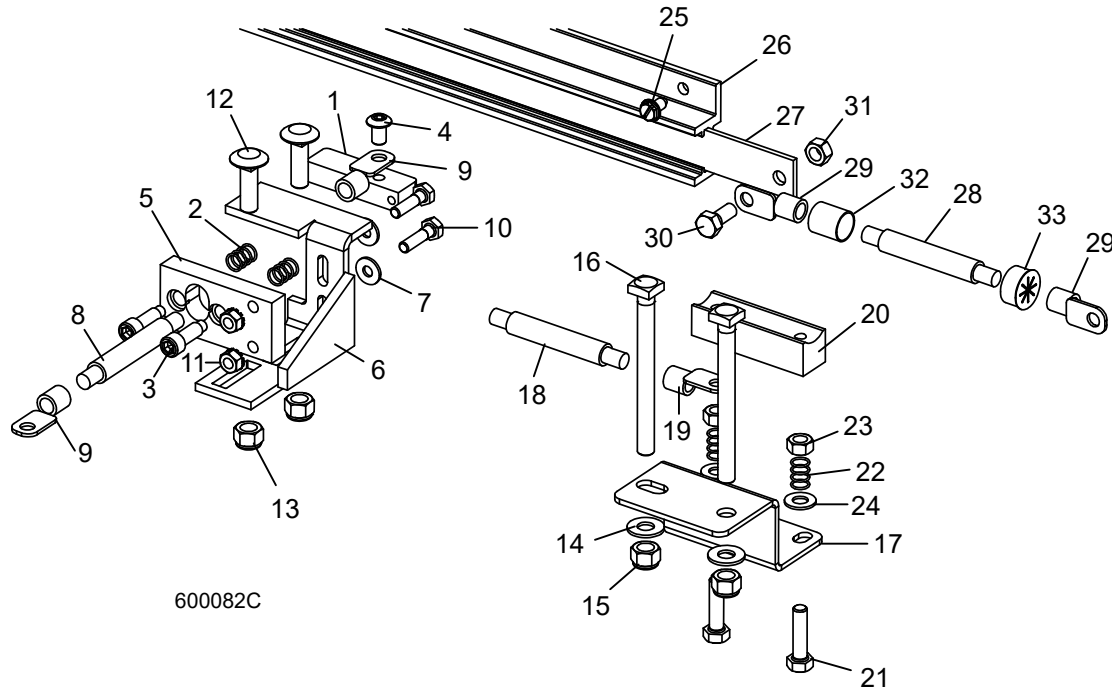

REF	DESCRIPTION (◆ Indicates Parts Available In Assemblies Only)	PART #	QTY.	
	CONTACT ASSEMBLY, HYDRAULIC POWER SUPPLY (POSITIVE)	010103	1	
	Contact Kit, 97+ Hydraulic Power Supply Positive	007716	1	
1	Contact, Hydraulic Power Supply (Positive)	015253	1	
2	Spring, Positive Contact	P10077	2	
3	Bolt, 5/16" X 3/4" Shoulder (1/4-20 Thread) Stainless	F05006-143 ¹	2	
4	Bolt, 5/16-18 x 1/2" Socket Button Head	F05006-20	1	
5	Insulator, Positive Contact	S10072	1	
6	Bracket, Positive Contact Mounting	015324	1	
7	Washer, 1/4" SAE Flat	F05011-11	2	
8	Cable, #1 Weld	R01971 ²	1.17 Ft	◆
9	Terminal, 5/16" Ring #2 Gauge	F05092-16 ²	2	
10	Bolt, 1/4-20 X 1" Hex Head Grade 2	F05005-38	2	
11	Nut, 1/4-20 Hex Self-Locking	F05010-9	2	
12	Bolt, 3/8-16 X 1 1/4" Carriage Head	F05007-11	2	
13	Nut, 3/8-16 Hex Nylon Lock	F05010-10	2	
	CONTACT KIT, HYDRAULIC POWER SUPPLY (GROUND)	017948	1	
14	Washer, 3/8" SAE Flat	F05011-3	2	
15	Nut, 3/8-16 Hex Nylon Lock	F05010-10	2	
16	Bolt, 3/8-16 X 4" Square Head	F05007-175	2	
17	Bracket, Ground Contact Mounting	017949	1	

10

Hydraulic System

Hydraulic Power Supply Strip (DC Only)

18	Cable Assy, Hydraulic Negative Contact (Ground) #1 Weld	036306	1	
	Cable, #1 Weld	R01971	2.2 Ft	◆
19	Terminal, 5/16" Ring #2 Gauge	F05092-16	2	
	Contact Kit, Hydraulic Power Supply Ground	007717	1	
20	Contact, Hydraulic Power Supply (Ground)	015264	1	
21	Bolt, 5/16-18 X 1 1/4" Hex Head Full Thread Grade 5	F05006-93	2	
22	Spring, Ground Contact	P10077	2	
23	Nut, 5/16-18 Hex	F05010-17	2	
24	Washer, 5/16" SAE Flat	F05011-17	2	
	STRIP ASSEMBLY, 6' HYDRAULIC POWER SUPPLY W/2 3FT. CABLES	015564	1	
25	Screw, 1/4-20 X 1/2" Slotted Hex Head	F05015-1	8	
26	Housing, 6' Contact Strip	P11976	1	
	Strip, 6' Contact With 2Cables	015886	1	
27	Strip, 6' Contact	S10075	1	◆
28	Cable Assembly, Hydraulic Contact Strip	052161	2	
	Cable, #1 Weld	R01971	3 Ft	◆
29	Terminal, 5/16" Ring #2 Gauge	F05092-16	2	
30	Bolt, 5/16-18 X 3/4" Hex Head Black Nylon	F05006-45	1	
31	Nut, 5/16-18 Hex Black Nylon	F05010-86	1	
32	Tube, 5/8" Heat Shrink	R01950-5	.33 Ft	◆
33	Grommet, 5/8" Wire	P04137	1	

¹ Stainless Steel Bolt F05006-143 replaces F05006-44 to prevent corrosion (Rev. B3.01).

² [See Section 5.12](#) for pre-assembled cable service assemblies.

10.11 Hydraulic Power Supply Strip (AC Only)

LT60HD/70HD (230/460V) Rev. A3.01 - A6.01
LT60HD/70HD (575V) Rev. A3.01 - B3.01

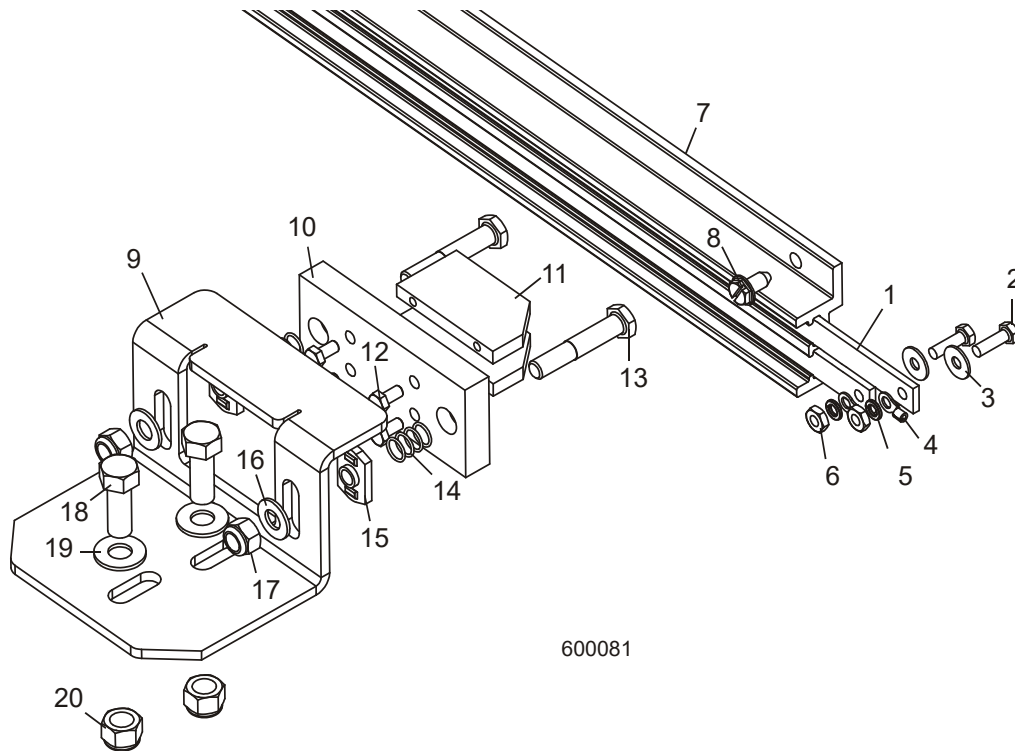

REF	DESCRIPTION (◆ Indicates Parts Available In Assemblies Only)	PART #	QTY.
	STRIP ASSEMBLY, HYDRAULIC POWER SUPPLY (AC)	034867 ¹	1
1	Strip, AC Hydraulic Power Supply	034866	2
2	Bolt, #10-32 x 5/8" Hex Head	F05004-152	2
3	Washer, #10 Brass	042867	2
4	Terminal, #10 14-16 Gauge Ring NI Loose	F05092-9	2
5	Washer, #10 Split Lock	F05011-20	1
6	Nut, #10-32 Hex	F05010-27	2
7	Housing, AC Hydraulic Power Supply	044015	1
8	Bolt, 1/4-20 x 1/2" Self-Tapping Hex Head	F05015-1	8
	CONTACT, HYDRAULIC POWER SUPPLY (AC)	034880	1
9	Bracket, Contact Mounting	034879	1
10	Block, AC Contact Insulating	034874	1
11	Block, AC Contact	034869	2
12	Bolt, #10-32 x 1/2" Hex Head	F05004-60	4
13	Bolt, 5/16-18 x 1 3/4" Hex Head	F05009-70	2
14	Spring, .42" x .59" x .042" Compression	P10077	2
15	Nut, 5/16-18 Stainless Steel Weld	F05010-179	2

10**Hydraulic System***Hydraulic Power Supply Strip (AC Only)*

16	Washer, 5/16" SAE Flat	F05011-17	2	
17	Nut, 5/16-18 Hex Nylon Lock	F05010-58	2	
18	Bolt, 3/8-16 x 1" Hex Head	F05007-7	2	
19	Washer, 3/8" SAE Flat	F05011-3	2	
20	Nut, 3/8-16 Hex Nylon Lock	F05010-10	2	

¹ Contact strip removed from 208-480V AC LT60HD/70HD Rev. A7.00. Hydraulics are now active by pushing a button on the hydraulic control box.

10.12 Hydraulic Log Loader

LT60HD/LT70HD

Rev. A7.05 - B3.01

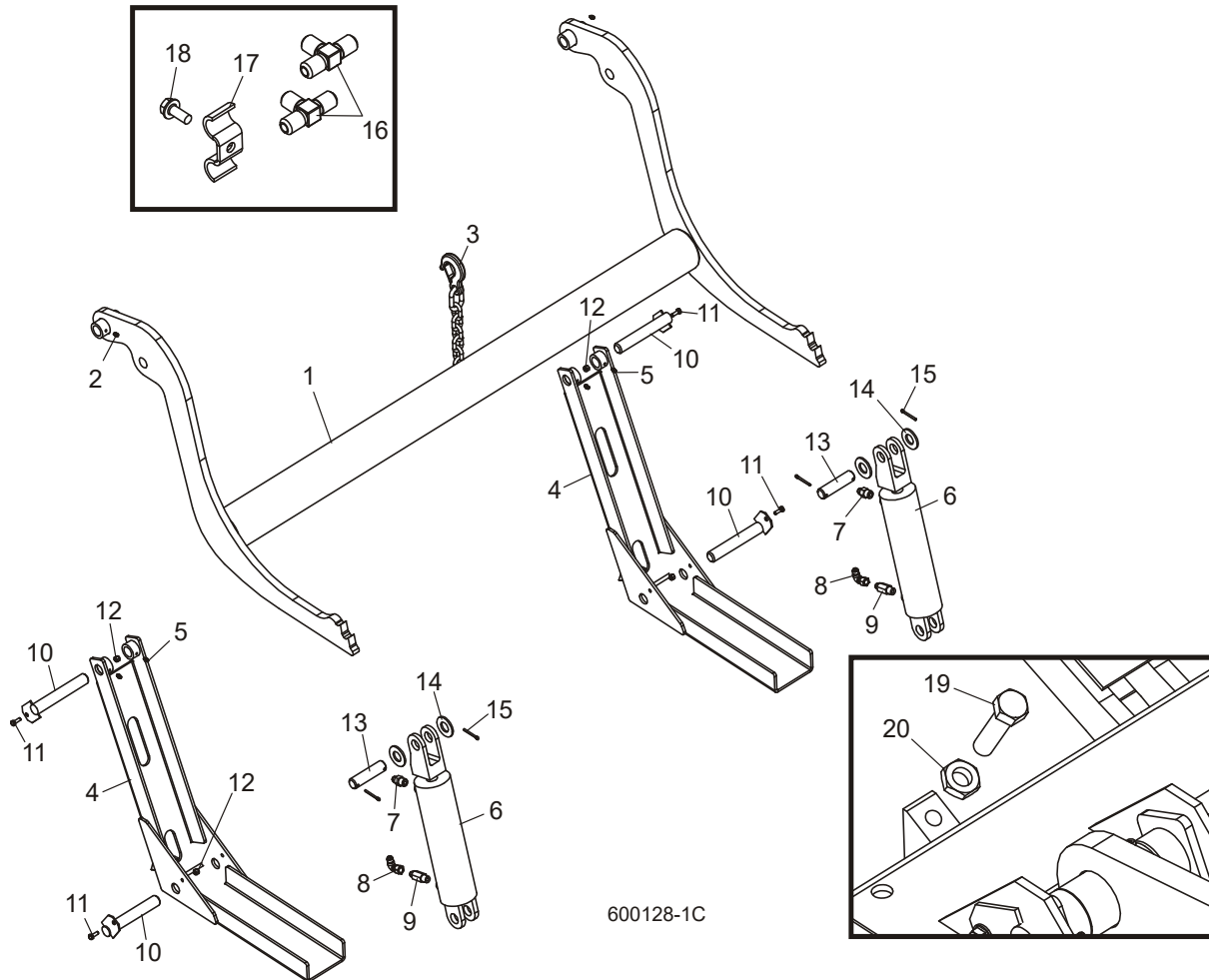

600128-1C

REF	DESCRIPTION (◆ Indicates Parts Available In Assemblies Only)	PART #	QTY.
	LOADER ASSEMBLY, HYDRAULIC LOG	034539	1
1	Arm, Hydraulic Log Loading	036416	1
2	Fitting, 3/16" Grease	P04107	2
3	Chain, Hydraulic Log Loader Safety	A04376	1
4	Channel, Hydraulic Log Loading Foot	W09444	2
5	Fitting, 3/16" Grease	P04107	4
	Cylinder Assembly, Hydraulic Log Loader	038735 ¹	2
6	Cylinder, 8" X 3" Hydraulic (3/8" NPT Ports)	042754	1
	Seal Kit, 8" x 3" Hydraulic Cylinder	P12956	1
7	Fitting, 3/8" NPT x 3/8" JIC Male Connector	016819	1
8	Fitting, 3/8" JIC 90° Swivel Elbow	042756	1

10

Hydraulic System

Hydraulic Log Loader

9	Fitting, 3/8NPT 6.5GPM Velocity Fuse	038734 ¹	1	
10	Pin, Loading Arm Mount	W09446	4	
11	Bolt, 1/4-20 x 3/4" Hex Head Full Thread	F05005-1	4	
12	Nut, 1/4-20 Hex Lock	F05010-69	4	
13	Pin, Loading Arm Cylinder Mount	S09251	2	
14	Washer, 1" SAE Flat	F05011-28	4	
15	Pin, 3/16" X 1 1/2" Cotter	F05012-23	4	
16	Fitting, 3/8" JIC Union 'T'	015487	1	
17	Clamp, 3/8" Hydraulic Hose	016041	6	
18	Bolt, 5/16-18 X 3/4" Hex Head Grade 5	F05006-102 ²	6	
19	BOLT, 1/2-13 X 3" HEX HEAD FULL THREAD GRADE 5	F05008-7	2	
20	NUT, 1/2-13 JAM	F05010-31	2	

¹ Cylinder Assembly 038735 with 6.5GPM velocity fuse 038734 replaces Cylinder Assembly 017645 with 6.0GPM velocity fuse 042755 to prevent loading arm from locking up when fully extended (Rev. A7.05).

² Grade 5 Hex Head Bolt F05006-102 replaces self-tapping bolt F05006-30 to eliminate shearing of bolts head (4/08).

10.13 Hydraulic Log Loader

LT60HD/LT70HD

Rev. A3.01 - A7.04

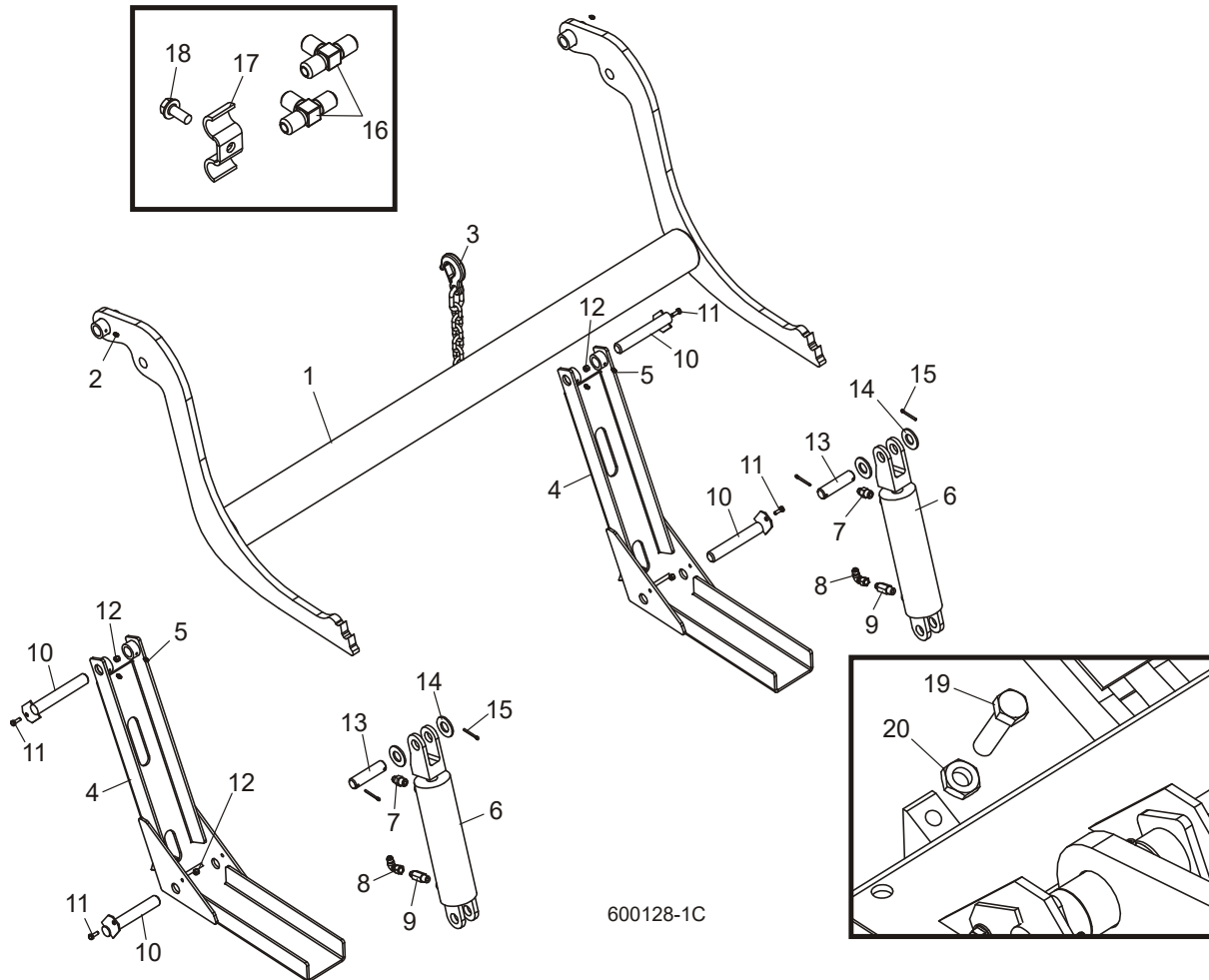

REF	DESCRIPTION (◆ Indicates Parts Available In Assemblies Only)	PART #	QTY.
	LOADER ASSEMBLY, HYDRAULIC LOG (LT60HD/70HD)	034539	1
1	Arm, Hydraulic Log Loading	036416 ¹	1
2	Fitting, 3/16" Grease	P04107	2
3	Chain, Hydraulic Log Loader Safety	A04376	1
4	Channel, Hydraulic Log Loading Foot	W09444	2
5	Fitting, 3/16" Grease	P04107	4
	Cylinder Assembly, Hydraulic Log Loader	017645	2
6	Cylinder, 8" X 3" Hydraulic (3/8" NPT Ports)	042754	1
	Seal Kit, 8" x 3" Hydraulic Cylinder	P12956	1
7	Fitting, 3/8" NPT x 3/8" JIC Male Connector	016819	1
8	Fitting, 3/8" JIC 90° Swivel Elbow	042756	1
9	Fitting, 3/8NPT 6.0GPM Velocity Fuse	042755	1

10

Hydraulic System

Hydraulic Log Loader

10	Pin, Loading Arm Mount	W09446	4	
11	Bolt, 1/4-20 x 3/4" Hex Head Full Thread	F05005-1	4	
12	Nut, 1/4-20 Hex Lock	F05010-69	4	
13	Pin, Loading Arm Cylinder Mount	S09251	2	
14	Washer, 1" SAE Flat	F05011-28	4	
15	Pin, 3/16" X 1 1/2" Cotter	F05012-23	4	
16	Fitting, 3/8" JIC Union 'T'	015487	1	
17	Clamp, 3/8" Hydraulic Hose	016041	6	
18	Bolt, 5/16-18 X 3/4" Hex Head Grade 5	F05006-102 ²	6	
19	BOLT, 1/2-13 X 3" HEX HEAD FULL THREAD GRADE 5	F05008-7	2	
20	NUT, 1/2-13 JAM	F05010-31	2	

¹ Loading Arm Weldment 036416 replaces W11805 originally supplied prior to Rev. A3.02. Redesigned arm provided easier loading of logs onto arm.

² Grade 5 Hex Head Bolt F05006-102 replaces self-tapping bolt F05006-30 to eliminate shearing of bolts head (4/08).

10.14 Hydraulic Log Turner

LT60HD/70HD

Rev. B2.00 - B3.01

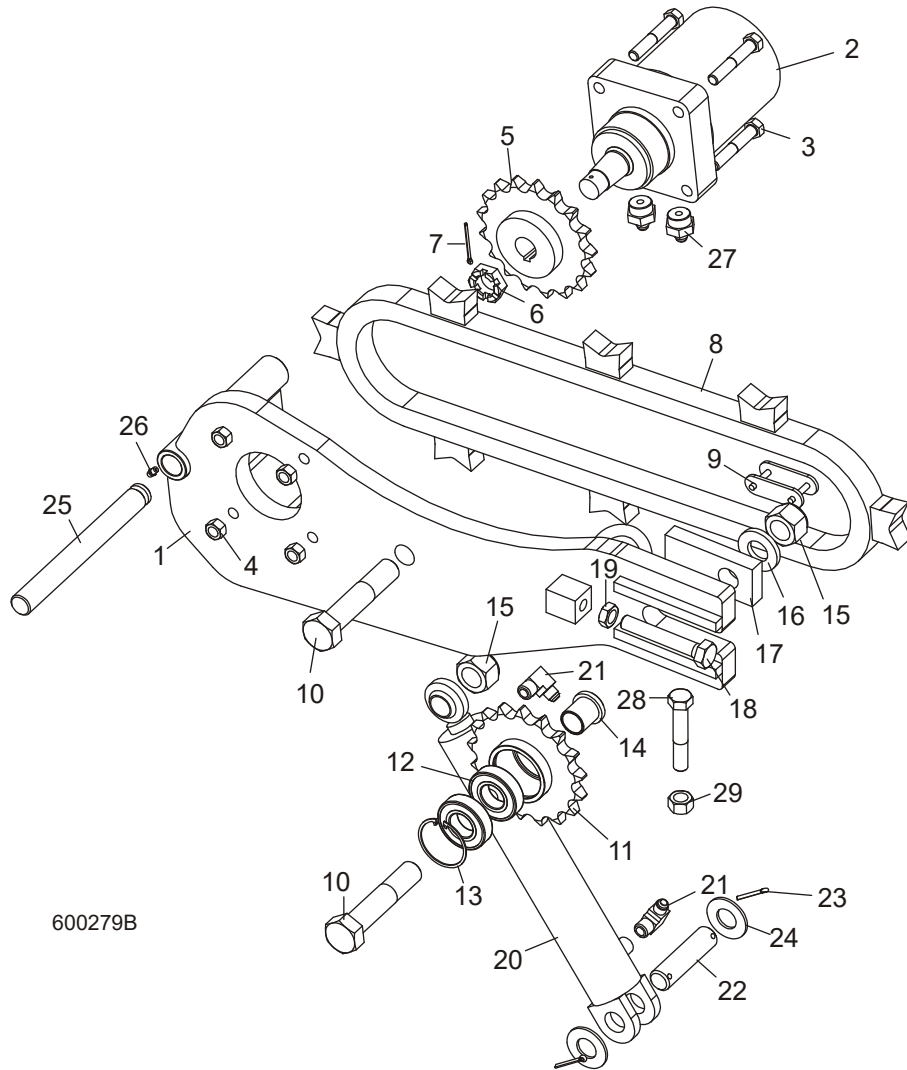

REF	DESCRIPTION (◆ Indicates Parts Available In Assemblies Only)	PART #	QTY.
	ARM ASSEMBLY, HYDRAULIC LOG TURNER	006095	1
1	Arm Weldment, Hydraulic Log Turner	006471	1
2	Motor, Hydraulic Log Turner	007331 ¹	1
3	Bolt, 1/2-13 x 3" Hex Head Grade 5	F05008-23	4
4	Nut, 1/2-13 Hex Lock	F05010-3	4
5	Sprocket Weldment, Log Turner Drive	042192	1
6	Nut, Hydraulic Motor Castle	018741-2	1
7	Pin, 1/8" x 1 3/4" Cotter	F05012-43	1
8	Chain Weldment, Log Turner	006097	1
9	Link, #2080H Master	016796	1

10

Hydraulic System Hydraulic Log Turner

10	Bolt, 1-8 x 5" Hex Head Grade 8	F05004-132	2	
	Sprocket Assembly, Idler	042193	1	
11	Sprocket Weldment, Idler	042191	1	
12	Bearing, 6206 25 Idler	P11035	2	
13	Ring, 62mm #472 DIN Inside Retaining	F04254-12	1	
14	Spacer, Idler Sprocket	042187	2	
15	Nut, 1-8 Hex Lock	F05010-109	2	
16	Washer, 1" ID x 2" OD x 1/4"	038749	1	
17	Plate, Log Turner Chain Tensioner	042188	1	
18	Bolt, 5/8-11 x 4" Hex Head Full Thread Grade 5	F05009-31	1	
19	Nut, 5/8-11 Hex Jam	F05010-82	1	
20	Cylinder, 2" x 10" Welded Rod End Hydraulic	034267	1	
	Seal Kit, 2x10 Hydraulic Cylinder	003814	1	
21	Fitting, 3/8" NPT x 3/8" JIC 90° Elbow	016820	2	
22	Pin, 1" x 3.88"	S09251	1	
23	Pin, 3/16" x 1 1/2" Cotter	F05012-23	2	
24	Washer, 1" SAE Flat	F05011-28	2	
25	Rod, Grooved Turner Mount	006722	1	
26	Fitting, 1/4-28 Grease	P05060	1	
27	Fitting, #10 SAE x 3/8" JIC Straight	017640	2	
28	BOLT, 5/8-18 X 3 1/2" HEX HEAD BOLT FULL THREAD	F05009-16	1	
29	NUT, 5/8-18 HEX	F05010-50	1	

¹ Hydraulic Motor 007331 replaces 018741 originally supplied prior to 6/09. 018741 was changed by the vendor and no longer fits the hole in the log turner arm.

10.15 Hydraulic Log Turner

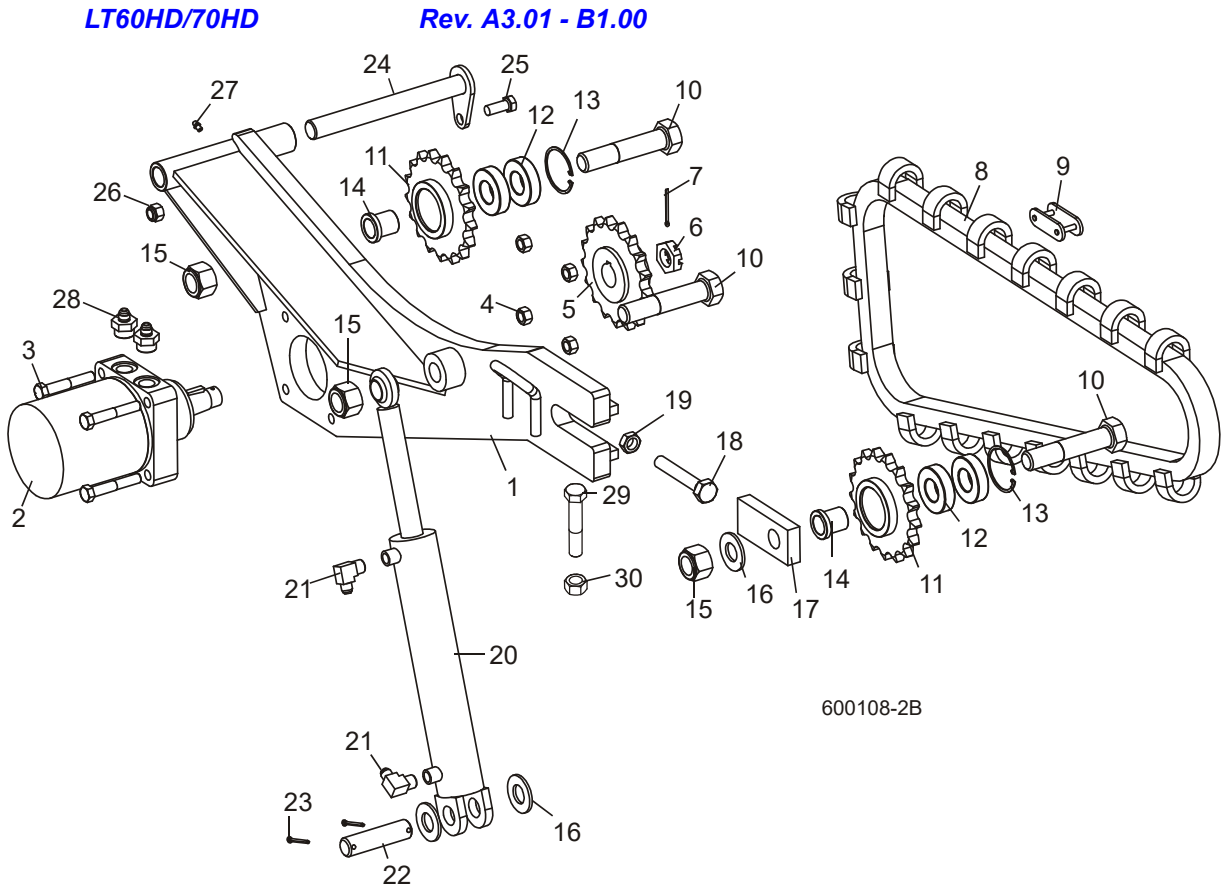

REF	DESCRIPTION (◆ Indicates Parts Available In Assemblies Only)	PART #	QTY.
	ARM ASSEMBLY, HYDRAULIC LOG TURNER	034537	1
1	Arm Weldment, Hydraulic Log Turner	016873	1
2	Motor, Hydraulic Log Turner	007331 ¹	1
3	Bolt, 1/2-13 x 3" Hex Head Grade 5	F05008-23	4
4	Nut, 1/2-13 Hex Lock	F05010-3	4
5	Sprocket Weldment, Log Turner Drive	042192	1
6	Nut, Hydraulic Motor Castle	018741-2	1
7	Pin, 1/8" x 1 3/4" Cotter	F05012-43	1
8	Chain Weldment, Log Turner	025655 ²	1
	Cog, Log Turner	042194 ³	17
	Chain, #2080 Log Turner	042195	1
9	Link, #2080H Master	016796	1
10	Bolt, 1-8 x 5" Hex Head Grade 8	F05004-132	3
	Sprocket Assembly, Idler	042193	2
11	Sprocket Weldment, Idler	042191	1
12	Bearing, 6206 25 Idler	P11035	2

10

Hydraulic System Hydraulic Log Turner

13	Ring, 62mm #472 DIN Inside Retaining	F04254-12	1	
14	Spacer, Idler Sprocket	042187	2	
15	Nut, 1-8 Hex Lock	F05010-109	3	
16	Washer, 1" SAE Flat	F05011-28	3	
17	Plate, Log Turner Chain Tensioner	042188	1	
18	Bolt, 5/8-11 x 4" Hex Head Full Thread Grade 5	F05009-31	1	
19	Nut, 5/8-11 Hex Jam	F05010-82	1	
20	Cylinder, 2" x 10" Welded Rod End Hydraulic	034267	1	
	Seal Kit, 2x10 Hydraulic Cylinder	003814	1	
21	Fitting, 3/8" NPT x 3/8" JIC 90° Elbow	016820	2	
22	Pin, 1" x 3.88"	S09251	1	
23	Pin, 3/16" x 1 1/2" Cotter	F05012-23	2	
24	Pin Weldment, Log Turner Mount	042331	1	
25	Bolt, 1/2-13 x 1 1/4" Hex Head Grade 5	F05008-37	1	
26	Nut, 1/2-13 Hex Nylon Lock	F05010-8	1	
27	Fitting, 1/4-28 Grease	P05060	1	
28	FITTING, #10 SAE X 3/8" JIC STRAIGHT	017640	2	
29	BOLT, 5/8-18 X 3 1/2" HEX HEAD BOLT FULL THREAD	F05009-16	1	
30	NUT, 5/8-18 HEX	F05010-50	1	

¹ Hydraulic Motor 007331 replaces 018741 originally supplied prior to 6/09. 018741 was changed by the vendor and no longer fits the hole in the log turner arm.

² Turner Chain 025655 replaces original chain 042196 supplied prior to 4/10. New chain provides more aggressive log turning.

³ Applies to original Turner Chain 042196 only.

10.16 Hydraulic Log Side Supports (Front)

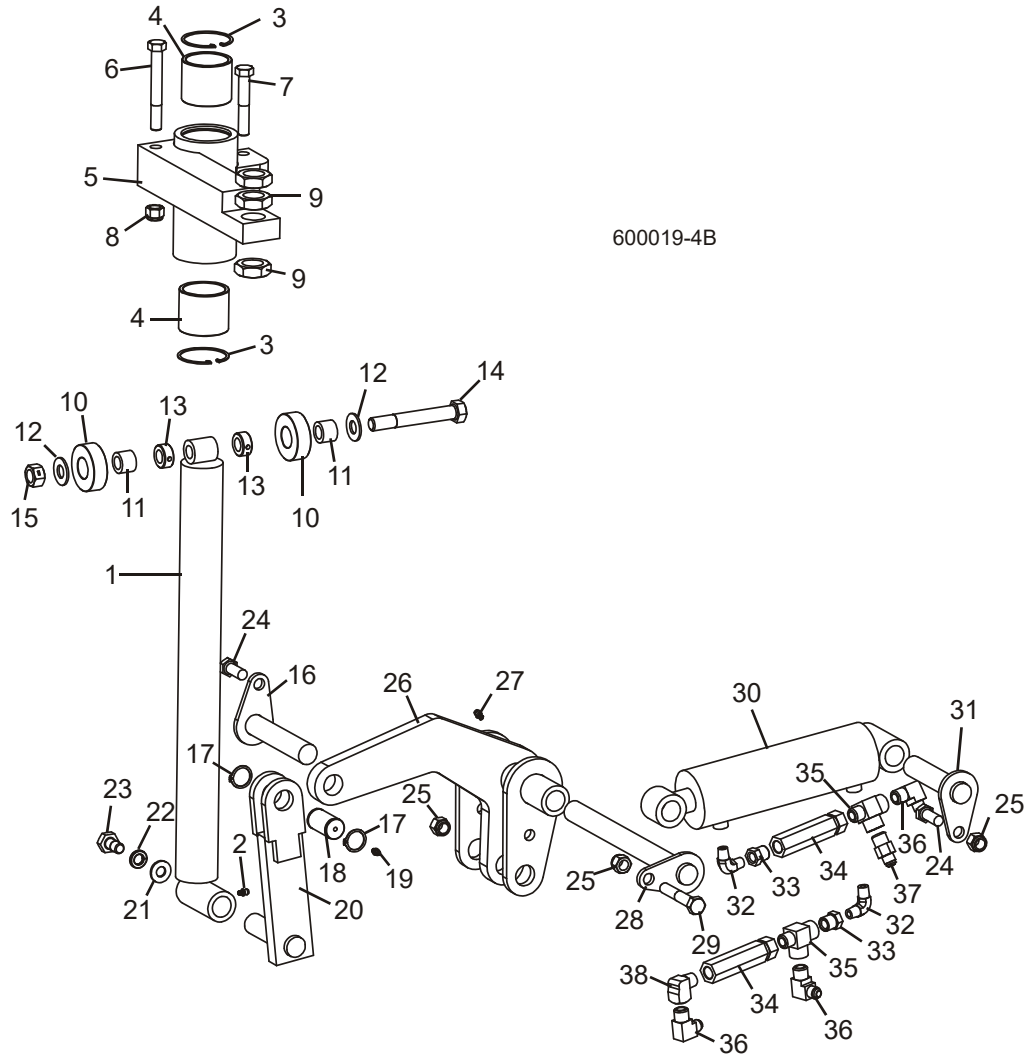

REF	DESCRIPTION (◆ Indicates Parts Available In Assemblies Only)	PART #	QTY.
	SUPPORT ASSEMBLY, VERTICAL HYDRAULIC SIDE	034732	1
1	Rod Weldment, Vertical Side Support	034704	1
2	Fitting, 3/16" Straight Grease	P04107	1
3	Ring, 62mm Din #472 Inside Retaining	F04254-12	2
4	Bushing, Side Support	042262	2
5	Mount Weldment, Vertical Side Support	034703	1
6	Bolt, 1/2-13 x 4" Hex Head Grade 5	F05008-78	1
7	Bolt, 1/2-13 x 3" Hex Head Grade 5	F05008-23	1
8	Nut, 1/2-13 Hex Nylon Lock	F05010-8	2
9	Nut, 1-14 Hex Jam	F05010-118	3
	Roller Kit, Side Support	034733	1

10

Hydraulic System

Hydraulic Log Side Supports (Front)

10	Roller, Side Support	016561	2	
11	Bushing, 5/8" x 1" x 3/4" Bronze	016560	2	
12	Washer, 5/8" SAE Flat	F05011-5	2	
13	Collar, 5/8" Lock	P05035	2	
14	Bolt, 5/8-11 x 4 1/2" Hex Head Grade 5	F05009-10	1	
15	Nut, 5/8-11 Hex Lock	F05010-4	1	
16	PIN WELDMENT, 5 1/4" PIVOT	034727	1	
	PIN ASSEMBLY, SIDE SUPPORT PIVOT	036053	1	
17	Pin, Grooved Pivot	034718	1	◆
18	Ring, 1" 3100-100 Outside Retaining	F04254-15	2	
19	Fitting, 3/16" Straight Grease	P04107	1	
20	PUSHER WELDMENT, LOWER SIDE SUPPORT	034711	1	
21	WASHER, 9/16" SAE FLAT	F05011-52	1	
22	WASHER, 1/2" SPLIT LOCK	F05011-9	1	
23	BOLT, 1/2-13 X 1" HEX HEAD	F05008-50	1	
24	BOLT, 1/2"-13 X 1 1/4" HEX HEAD GRADE 5	F05008-37	2	
25	NUT, 1/2-13 HEX NYLON LOCK	F05010-8	3	
26	ARM WELDMENT, VERTICAL SIDE SUPPORT FRONT LIFT	034715	1	
27	FITTING, 3/16" STRAIGHT GREASE	P04107	1	
28	PIN WELDMENT, 10 7/8" PIVOT	034728	1	
29	BOLT, 1/2-13 X 3" HEX HEAD GRADE 5	F05008-23	1	
30	CYLINDER, 2 1/2" X 6" X 1/4" NPT PORT HYDRAULIC	034736	1	
31	PIN WELDMENT, 4 3/8" PIVOT	034726	1	
32	FITTING, 1/4" NPT MALE PIPE ELBOW	P09140	2	
33	FITTING, 3/8" NPT X 1/4" NPT REDUCER	015490	2	
34	VALVE, SIDE SUPPORT SEQUENCE	015484	2	
35	FITTING, 3/8" NPT MALE RUN TEE	016822	2	
36	FITTING, 3/8" NPT X 3/8" JIC ELBOW	016820	3	
37	FITTING, 3/8" NPT X 3/8" JIC CONNECTOR	016819	1	
38	FITTING, 3/8" NPT STREET ELBOW	P05759	1	

10.17 Hydraulic Log Side Supports (Rear)

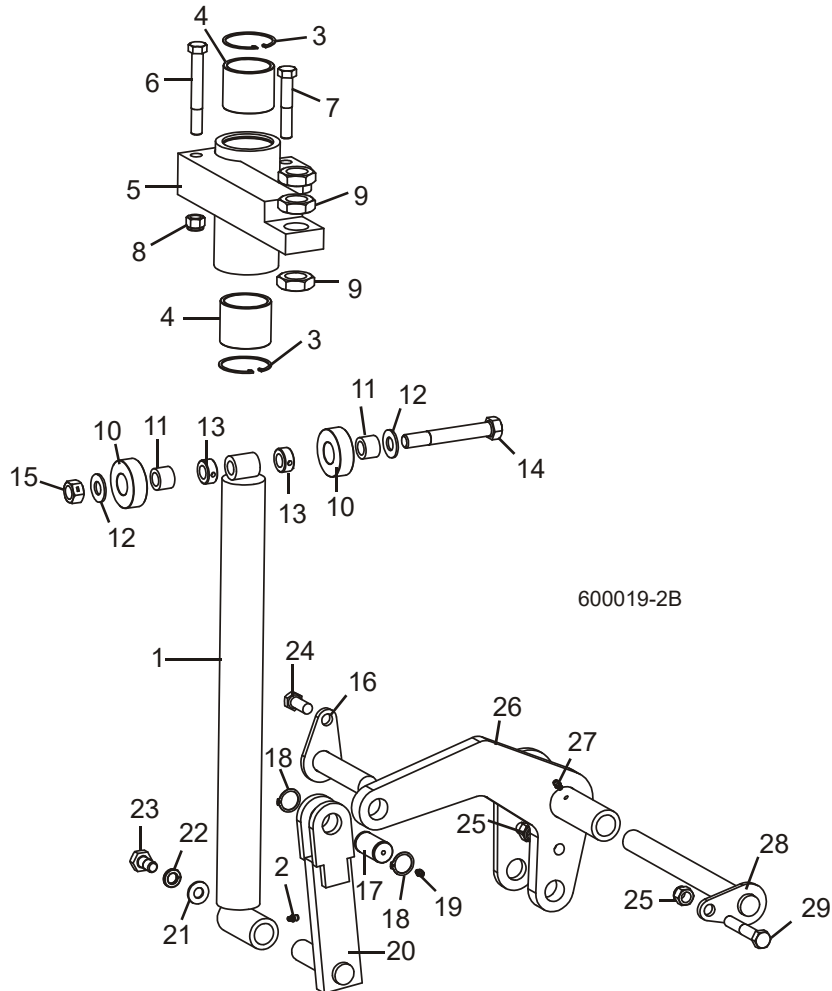

REF	DESCRIPTION (◆ Indicates Parts Available In Assemblies Only)	PART #	QTY.
	SUPPORT ASSEMBLY, VERTICAL HYDRAULIC SIDE	034732	1
1	Rod Weldment, Vertical Side Support	034704	1
2	Fitting, 3/16" Straight Grease	P04107	1
3	Ring, 62mm Din #472 Inside Retaining	F04254-12	2
4	Bushing, Side Support	042262	2
5	Mount Weldment, Vertical Side Support	034703	1
6	Bolt, 1/2-13 x 4" Hex Head Grade 5	F05008-78	1
7	Bolt, 1/2-13 x 3" Hex Head Grade 5	F05008-23	1
8	Nut, 1/2-13 Hex Nylon Lock	F05010-8	2
9	Nut, 1-14 Hex Jam	F05010-118	3
	Roller Kit, Side Support	034733	1
10	Roller, Side Support	016561	2
11	Bushing, 5/8" x 1" x 3/4" Bronze	016560	2

10

Hydraulic System

Hydraulic Log Side Supports (Rear)

12	Washer, 5/8" SAE Flat	F05011-5	2	
13	Collar, 5/8" Lock	P05035	2	
14	Bolt, 5/8-11 x 4 1/2" Hex Head Grade 5	F05009-10	1	
15	Nut, 5/8-11 Hex Lock	F05010-4	1	
16	PIN WELDMENT, 4 3/8" PIVOT	034726	1	
	PIN ASSEMBLY, SIDE SUPPORT PIVOT	036053	1	
17	Pin, Grooved Pivot	034718	1	◆
18	Ring, 1" 3100-100 Outside Retaining	F04254-15	2	
19	Fitting, 3/16" Straight Grease	P04107	1	
20	PUSHER WELDMENT, LOWER SIDE SUPPORT	034711	1	
21	WASHER, 9/16" SAE FLAT	F05011-52	1	
22	WASHER, 1/2" SPLIT LOCK	F05011-9	1	
23	BOLT, 1/2-13 X 1" HEX HEAD	F05008-50	1	
24	BOLT, 1/2"-13 X 1 1/4" HEX HEAD GRADE 5	F05008-37	2	
25	NUT, 1/2-13 HEX NYLON LOCK	F05010-8	2	
26	ARM WELDMENT, VERTICAL SIDE SUPPORT REAR LIFT	034716	1	
27	FITTING, 3/16" STRAIGHT GREASE	P04107	1	
28	PIN WELDMENT, 10 7/8" PIVOT	034728	1	
29	BOLT, 1/2-13 X 3" HEX HEAD GRADE 5	F05008-23	1	

10.18 Hydraulic Log Side Supports (Link)

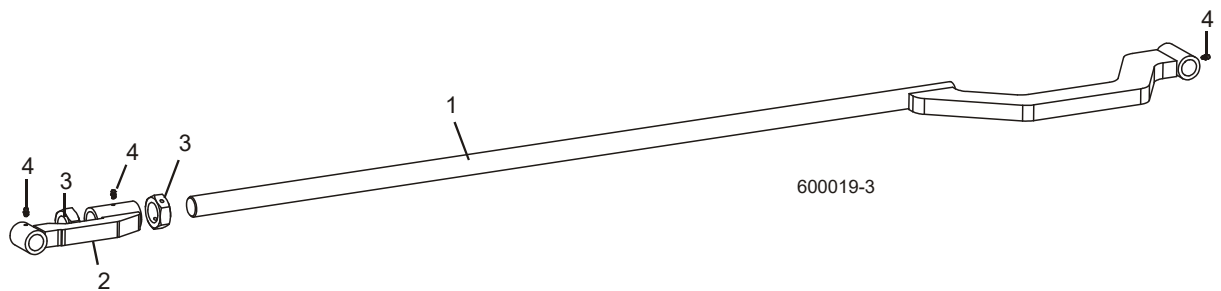

REF	DESCRIPTION (◆ Indicates Parts Available In Assemblies Only)	PART #	QTY.	
1	ROD WELDMENT, SIDE SUPPORT LINK	034725	1	
2	ARM WELDMENT, SIDE SUPPORT LINK	034724	1	
3	NUT, 1 1/4"-12 HEX JAM	F05010-100	2	
4	FITTING, 3/16" STRAIGHT GREASE	P04107	3	

10.19 Hydraulic Log Clamp

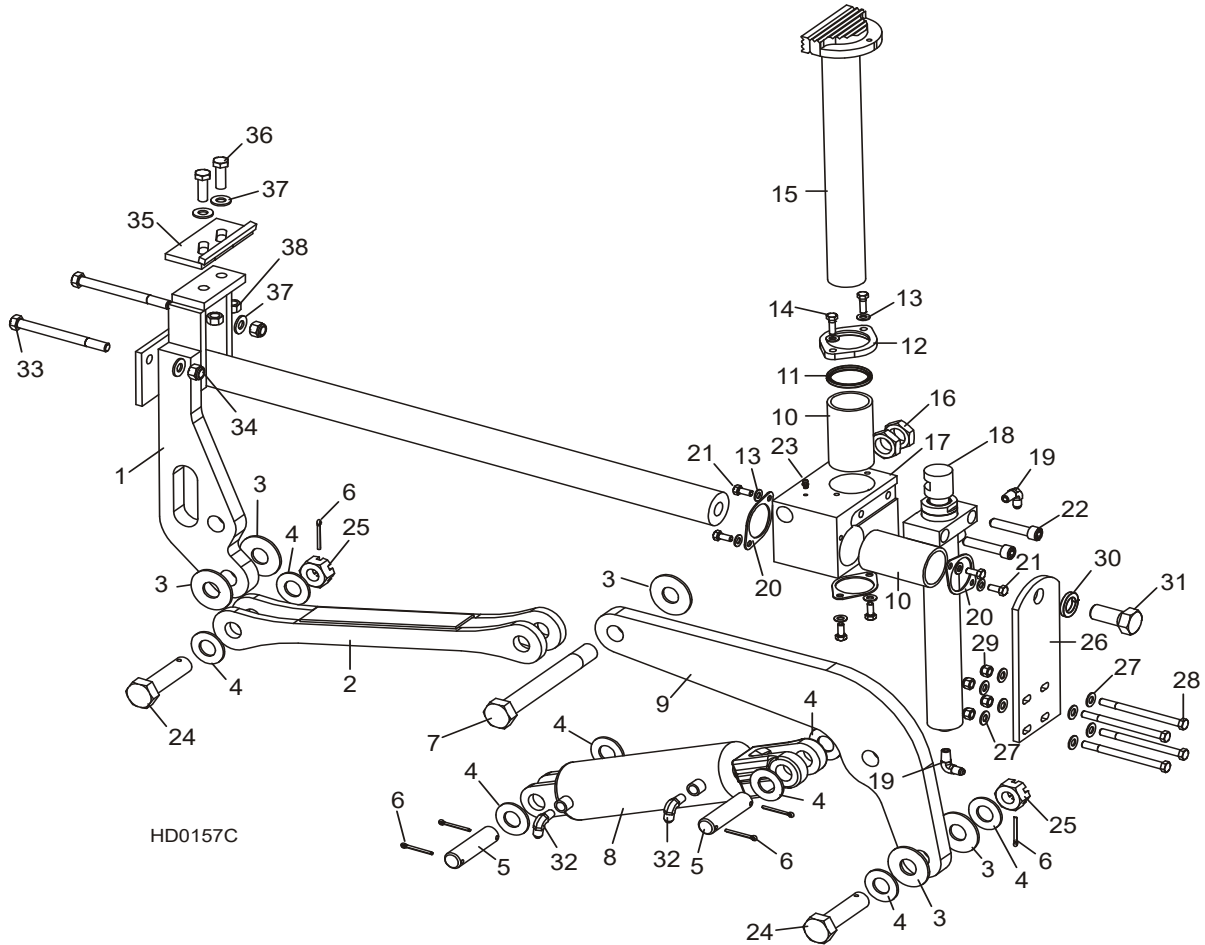

REF	DESCRIPTION (◆ Indicates Parts Available In Assemblies Only)	PART #	QTY.
	CLAMP ASSEMBLY, HYDRAULIC 2-PLANE	017264	1
1	Mount Weldment, Hydraulic Clamp Slide	017265	1
2	Link Weldment, Hydraulic Clamp	017267	1
3	Washer, 1/8" x 2 1/2" Hardened	015057	5
4	Washer, 1" SAE Flat	F05011-28	8
5	Pin, 1" x 3.88"	S09251	2
6	Pin, 3/16" x 1 1/2" Cotter	F05012-23	6
7	Bolt, 1-14 x 8 1/2" Hex Head Grade 8	015049	1
8	Cylinder, 3" x 7" Hydraulic	017275	1
	Seal Kit, Hydraulic Cylinder	P12956	1
9	Arm, Clamp Pivot	017274	1
10	Bushing, Clamp Slide	015088	2
	Wiper Assembly, Vertical Clamp Rod	017271	1
11	Wiper, Vertical Clamp Rod	017273	1

12	Flange, Vertical Clamp Rod Wiper	017272	1	
13	Washer, 5/16" SAE Flat	F05011-17	8	
14	Bolt, 5/16-18 x 1" Hex Head	F05006-1	2	
15	Clamp Weldment, Vertical	015043	1	
16	Nut, 1-14 Hex Jam	F05010-118	2	
17	Block, Hydraulic Clamp Slide	017270	1	
18	Cylinder Weldment, Vertical Clamp Hydraulic	015050	1	
	Seal Kit, Hydraulic Cylinder	016204	1	
	Instruction Sheet, Vertical Clamp Seal Replacement	016204-1009	1	
19	Fitting, 1/4" NPT x 1/4" JIC Elbow	P09142	2	
20	Retainer, Clamp Bushing	017242	3	
21	Bolt, 5/16-18 x 3/4" Hex Head	F05006-5	6	
22	Bolt, 1/2-13 x 2 1/2" Socket Head	F05008-39	2	
23	Fitting, 3/16" Straight Grease	P04107	1	
24	Bolt, 1-14 x 3 3/4" Hex Head Grade 8 w/Hole	015072 ¹	2	
25	Nut, 1-14 Slotted Hex	F05010-163	2	
26	Plate, Log Clamp Mount	015068	1	
27	Washer, 3/8" SAE Flat	F05011-3	8	
28	Bolt, 3/8-16 x 5" Hex Head	F05007-5	4	
29	Nut, 3/8-16 Hex Nylon Lock	F05010-10	4	
30	Washer, 7/8" Split Lock	F05011-46	1	
31	Bolt, 7/8-14 x 2" Hex Head Grade 5	F05014-2	1	
32	Fitting, 1/4" NPT - 3/8" JIC Elbow	015491	2	
33	Bolt, 1/2-13 x 5 1/2" Hex Head Grade 5	F05008-28	2	
34	Nut, 1/2-13 Hex Nylon Lock	F05010-8	2	
	Clamp Stop Kit, Hydraulic Log	K09485	1	
35	Plate, Clamp Stop	W09404	1	
36	Bolt, 1/2-13 X 1 1/2" Hex Head Grade 5	F05008-33	2	
37	Washer, 1/2" SAE Flat	F05011-2	2	
38	Nut, 1/2-13 Hex Lock	F05010-3	2	

¹ Bolt shortened from 4" to 3 3/4" to reduce interference on LT60HD/60HD models. 4" bolts can be used on other models (1/04).

10.20 Hydraulic Toe Board

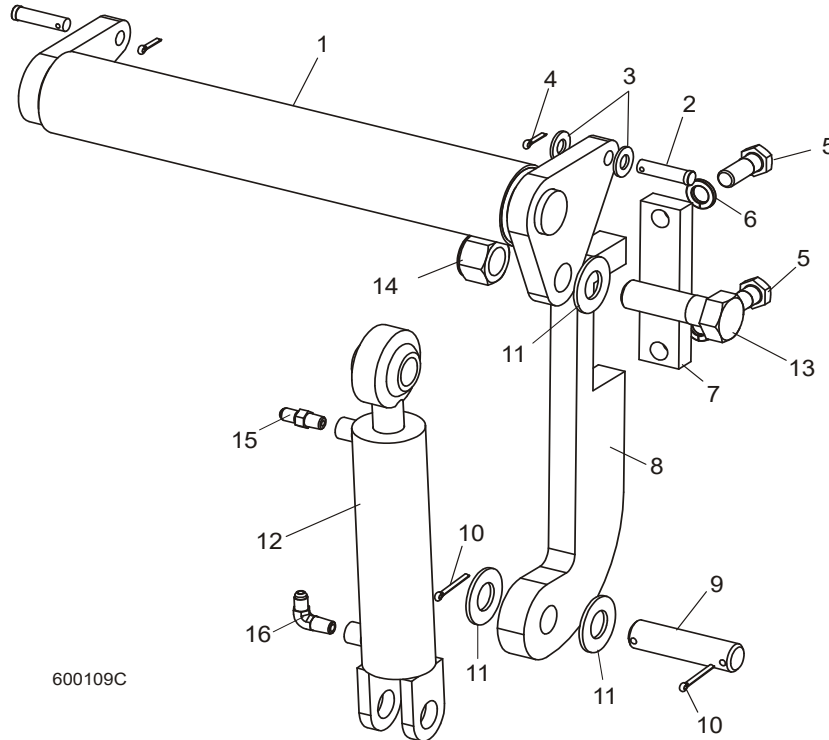

600109C

REF	DESCRIPTION (◆ Indicates Parts Available In Assemblies Only)	PART #	QTY.
1	TOE BOARD WELDMENT, HYDRAULIC	W13025	2
2	PIN, 1/2-1 3/4 CLEVIS	F05012-82	4
3	WASHER, 1/2" SAE FLAT	F05011-2	4
4	PIN, 1/8 X 3/4" COTTER	F05012-3	4
5	BOLT, 5/8-11 X 1 3/4" HEX HEAD	F05009-33	4
6	WASHER, 5/8" SPLIT LOCK	F05011-27	4
7	PLATE, HYDRAULIC TOEBOARD MOUNT	S13023	2
8	BRACKET, HYDRAULIC TOEBOARD MOUNT	S13022	2
9	PIN, CYLINDER MOUNT	S09251	2
10	PIN, 3/16" X 1 1/2" COTTER	F05012-23	4
11	WASHER, 1" SAE FLAT	F05011-28	6
12	CYLINDER, 1 1/2" X 6" HYDRAULIC TOE BOARD	014482	2
	Seal Kit, 1 1/2" x 6" Hydraulic Cylinder	014547	1
13	BOLT, 1-8 X 3 1/4" HEX HEAD GRADE 5	F05009-51	2
14	NUT, 1-8 HEX NYLON LOCK	F05010-109	2
15	FITTING, 1/4" NPT X 1/4" JIC MALE	P09143	2
16	FITTING, 1/4" NPT X 1/4" JIC MALE ELBOW	P09142	2

INDEX

A

autoclutch assembly 4-5, 4-7

B

battery box 5-16, 5-18

bed rails

front/rear 8-1, 8-3

middle front 8-5

middle rear 8-6

pivot 8-13

belt tensioner 4-2

blade guide arm

drive 2-19

blade guides

drive side roller 2-10, 2-13, 2-16

idle side roller 2-1, 2-4, 2-7

throat screw 4-1

blade tensioner 3-7, 3-10, 3-15

blade wheels

drive side 3-1

idle side 3-3, 3-5

board return 4-9

board return table 8-10, 8-11

brake assembly 4-4

C

control box 5-1, 5-4, 5-7

circuit breakers 5-11, 5-12, 5-13

drum switches 5-10

front panel & harnesses 5-14

covers

blade housing 4-13, 4-15

D

debarker wire box/hole plugs 4-20

decals

frame 8-19, 8-20

saw head 4-12

F

feed chain 7-5, 7-7, 7-9

fuse box 5-20, 5-22

H

hydraulic

control box (230/460V AC) 10-16, 10-18

control box (575V AC) 10-20

hoses 10-1, 10-3

log clamp 10-39

log loader 10-26, 10-28

log turner 10-30, 10-32

power strip 10-22

power strip (AC) 10-24

power strip (DC) 10-22

pump box (230/460V AC) 10-8

pump box (575V AC) 10-11

pump box (AC) 10-13

pump box (DC) 10-5

side supports 10-34

side supports (link) 10-38

side supports (rear) 10-36

toe board 10-41

M

manuals 9-1

O

outfeed table option 8-21

P

parts list
 how to use 1-1

power feed 7-3

R

rest pin 8-18

S

sawdust chute 4-19

side supports 8-15

T

track rollers
 lower 7-11
 upper 7-1

U

up/down
 assist 6-8
 blade scales 6-3
 chain & sprockets 6-4
 drive 6-6
 saw head mount 6-1

W

water lube
 bottle/tray 4-10
