



# Wood-Mizer<sup>®</sup> Sawmill

## Parts Manual

---

**LT50HD Wireless**

**rev. A2.01 - A5.02**

---



**Safety is our #1 concern!** Read and understand all safety information and instructions before operating, setting up or maintaining this machine.

*March 2008*

*Form #1548*

# Table of Contents

# Section-Page

<b>SECTION 1</b>	<b>GENERAL INFORMATION</b>	<b>1-1</b>
1.1	How To Use The Parts List .....	1-1
1.2	Sample Assembly .....	1-1
<b>SECTION 2</b>	<b>BLADE GUIDE ROLLERS &amp; ARM</b>	<b>2-1</b>
2.1	Blade Guide Assembly, Idle Side.....	2-1
	<i>LT50HD Rev. A2.01 - A5.02</i>	
2.2	Blade Guide Assembly, Idle Side.....	2-4
	<i>LT50HD Rev. A1.01 - A2.00</i>	
2.3	Blade Guide Assembly, Drive Side.....	2-7
	<i>LT50HD Rev. A2.01 - A5.02</i>	
2.4	Blade Guide Assembly, Drive Side.....	2-10
	<i>LT50HD Rev. A1.01 - A2.00</i>	
2.5	Blade Guide Arm Drive Assembly.....	2-13
2.6	Blade Guide Arm.....	2-15
	<i>LT50HD Rev. A2.01 - A5.02</i>	
2.7	Blade Guide Arm.....	2-16
	<i>LT50HD Rev. A1.01 - A2.00</i>	
<b>SECTION 3</b>	<b>BLADE WHEELS &amp; TENSIONER</b>	<b>3-1</b>
3.1	Blade Drive Assembly.....	3-1
3.2	Idle Blade Wheel Assembly .....	3-3
3.3	Hydraulic Blade Tensioner Assembly.....	3-4
<b>SECTION 4</b>	<b>SAW HEAD</b>	<b>4-1</b>
4.1	Middle Throat Screw .....	4-1
4.2	Water Lube Solenoid Valve .....	4-2
4.3	Clutch Mount Assembly.....	4-3
4.4	Brake Assembly.....	4-4
4.5	Board Return Assembly .....	4-5
4.6	Water Lube Assembly .....	4-7
4.7	Saw Head Decals.....	4-9
	<i>LT50HD Rev. A2.00 (1/08) - A5.02</i>	
4.8	Blade Housing Covers.....	4-10
4.9	Drive Belt Covers .....	4-12
4.10	Sawdust Chute .....	4-13
4.11	Debarker Wire Box/Hole Plugs.....	4-14
<b>SECTION 5</b>	<b>CONTROL &amp; BATTERY BOXES</b>	<b>5-1</b>
5.1	Control Assembly.....	5-1
5.2	Cover Assembly .....	5-4
5.3	Drum Switches .....	5-6
5.4	Circuit Breakers.....	5-7
5.5	Front Panel Assembly & Harnesses .....	5-8
5.6	Battery Box Assembly.....	5-10
	<i>LT50HD Rev. A5.00 - A5.02</i>	

## Table of Contents

## Section-Page

5.7	Battery Box Assembly.....	5-12
	<i>LT50HD</i> <i>Rev. A1.01 - A4.00</i>	
5.8	Fuse Box Assembly.....	5-14
	<i>LT50HD</i> <i>Rev. A5.00 - A5.02</i>	
5.9	Fuse Box Assembly.....	5-16
	<i>LT50HD</i> <i>Rev. A1.01 - A4.00</i>	
<b>SECTION 6 UP/DOWN SYSTEM 6-1</b>		
6.1	Saw Head Mount.....	6-1
6.2	Blade Height & Quarter Scales.....	6-2
6.3	Up/Down Chain & Sprockets.....	6-4
6.4	Up/Down Motor Assembly.....	6-6
6.5	Up/Down Drive Assembly.....	6-7
<b>SECTION 7 FEED SYSTEM &amp; TRACK ROLLERS 7-1</b>		
7.1	Upper Track Rollers And Wipers.....	7-1
7.2	Power Feed Assembly.....	7-3
7.3	Feed Chain/Stop.....	7-5
	<i>LT50HD</i> <i>Rev. A3.00 - A5.02</i>	
7.4	Feed Chain/Stop.....	7-6
	<i>LT50HD</i> <i>Rev. A1.01 - A2.02</i>	
7.5	Lower Track Rollers.....	7-7
<b>SECTION 8 BED FRAME ASSEMBLY 8-1</b>		
8.1	Bed Rail Assembly, Front And Rear.....	8-1
8.2	Bed Rail Assembly, Middle Front.....	8-3
8.3	Bed Rail Assembly, Middle Rear.....	8-4
8.4	Leg Assembly (Stationary).....	8-6
8.5	Board Return Table Assembly.....	8-8
8.6	Pivot Bed Rail Assembly.....	8-9
8.7	Safety Chain Assembly.....	8-11
8.8	Saw Head Rest Pin Assembly.....	8-12
8.9	Bed Frame Decals.....	8-13
	<i>LT50HD</i> <i>Rev. A2.00 (1/08) - A5.02</i>	
8.10	Bed Frame Decals.....	8-14
	<i>LT50HD</i> <i>Rev. A1.01 - A2.00 (12/07)</i>	
8.11	Board Outfeed Table (Optional).....	8-15
<b>SECTION 9 MISCELLANEOUS 9-1</b>		
9.1	Replacement Manuals.....	9-1
<b>SECTION 10 HYDRAULIC SYSTEM 10-1</b>		
10.1	Hydraulic Hoses.....	10-1
	<i>LT50HD</i> <i>Rev. A4.00 - A5.02</i>	
10.2	Hydraulic Hoses.....	10-2
	<i>LT50HD</i> <i>Rev. A1.01 - A3.00</i>	
10.3	Hydraulic Control Box.....	10-3

## Table of Contents

## Section-Page

10.4	Hydraulic Power Supply Strip.....	10-6
10.5	Hydraulic Log Loader .....	10-8
10.6	Hydraulic Log Turner.....	10-10
	<i>LT50HD</i> <i>Rev. A4.00 - A5.02</i>	
10.7	Hydraulic Log Turner.....	10-12
	<i>LT50HD</i> <i>Rev. A1.01 - A3.00</i>	
10.8	Hydraulic Log Side Supports (Front).....	10-14
10.9	Hydraulic Log Side Supports (Rear).....	10-16
10.10	Hydraulic Log Side Supports (Link).....	10-18
10.11	Hydraulic Log Clamp.....	10-19
10.12	Hydraulic Toe Board.....	10-21

## INDEX

## I

## SECTION 1 GENERAL INFORMATION

### 1.1 How To Use The Parts List

- Use the table of contents or index to locate the assembly that contains the part you need.
- Go to the appropriate section and locate the part in the illustration.
- Use the number pointing to the part to locate the correct part number and description in the table.
- Parts shown indented under another part are included with that part.
- Parts marked with a diamond (◆) are only available in the assembly listed above the part.

See the sample table below. Sample Part #A01111 includes part F02222-2 and subassembly A03333. Subassembly A03333 includes part S04444-4 and subassembly K05555. The diamond (◆) indicates that S04444-4 is not available except in subassembly A03333. Subassembly K05555 includes parts M06666 and F07777-77. The diamond (◆) indicates M06666 is not available except in subassembly K05555.

1.2 Sample Assembly				
REF	DESCRIPTION (◆ Indicates Parts Available In Assemblies Only)	PART #	QTY.	
	<b>SAMPLE ASSEMBLY, COMPLETE (INCLUDES ALL INDENTED PARTS BELOW)</b>	A01111	1	
1	Sample Part	F02222-22	1	
	Sample Subassembly (Includes All Indented Parts Below)	A03333	1	
2	Sample Part (◆ Indicates Part Is Only Available With A03333)	S04444-4	1	◆
	Sample Subassembly (Includes All Indented Parts Below)	K05555	1	
3	Sample Part (◆ Indicates Part Is Only Available With K05555)	M06666	2	◆
4	Sample Part	F07777-77	1	

#### To Order Parts:

- From the continental U.S., call **1-800-525-8100** to order parts. Have your customer number, vehicle identification number, and part numbers ready when you call.
- From other international locations, contact the Wood-Mizer distributor in your area for parts.

# 2 Blade Guide Rollers & Arm

Blade Guide Assembly, Idle Side

## SECTION 2 BLADE GUIDE ROLLERS & ARM

### 2.1 Blade Guide Assembly, Idle Side

LT50HD

Rev. A2.01 - A5.02

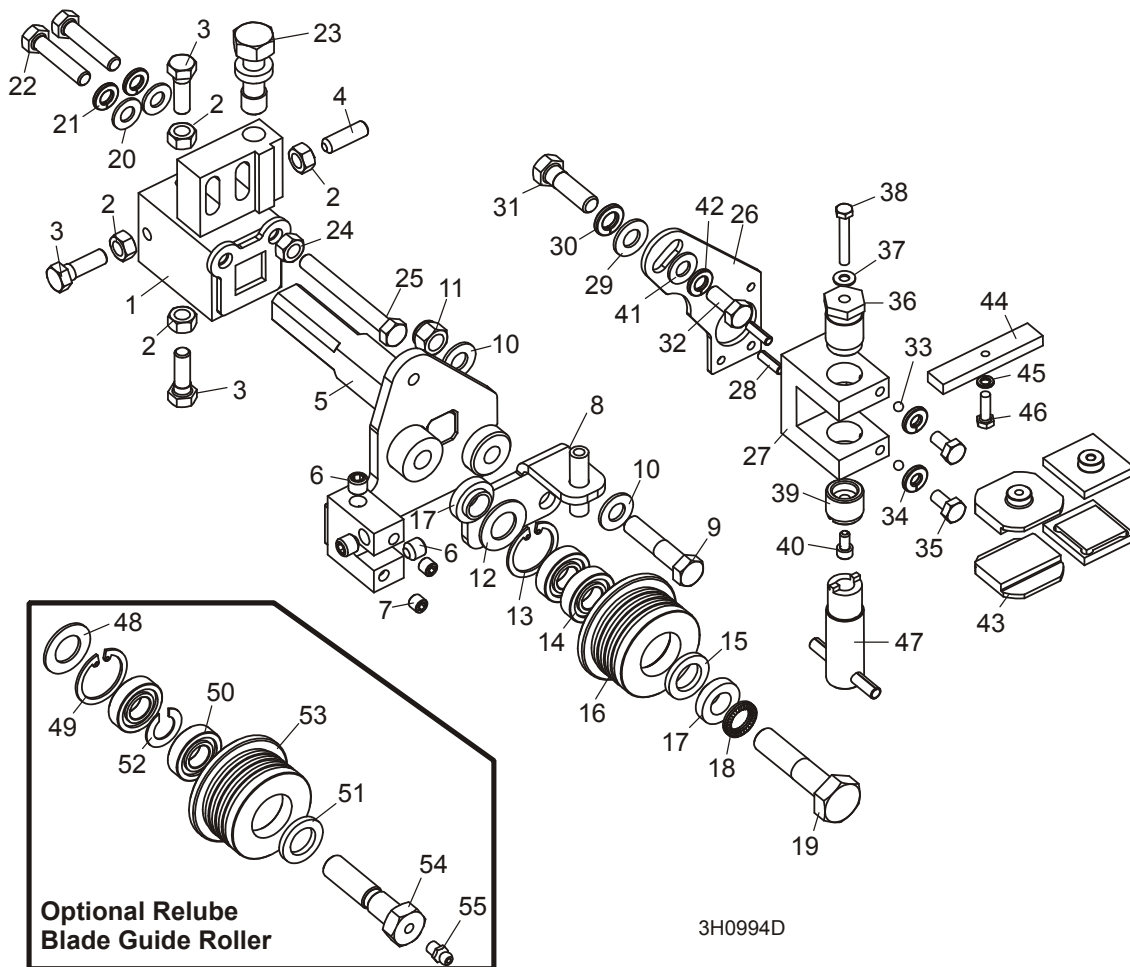

3H0994D

REF	DESCRIPTION (◆ Indicates Parts Available In Assemblies Only)	PART #	QTY.	
	<b>GUIDE ASSEMBLY, IDLE SIDE BLADE ROLLER</b>	003992	1	
	Block Assembly, Idle Side Blade Guide Mount	003920	1	
1	Block Weldment, Blade Guide Mount	003921	1	◆
2	Nut, 5/16-18 Hex	F05010-17	4	
3	Bolt, 5/16-18 x 1" Hex Head Stainless Steel	F05006-88	3	
4	Screw, 5/16-18 x 1" Socket Head Flat Point Stainless Steel Set	F05006-122	1	
5	Shaft Weldment, Idle Side Guide	003924 <sup>1</sup>	1	
6	Fitting, 1/8" NPT Socket Pipe Plug	P30127	3	
7	Fitting, 1/16" NPT Socket Pipe Plug	007734 <sup>1</sup>	2	

## Blade Guide Rollers & Arm

*Blade Guide Assembly, Idle Side*

2

8	Bracket Weldment, Idle Side Water Lube	006322	1	
9	Bolt, 3/8-16UNF-2A x 1 3/4" Grade 5	F05007-119	1	
10	Washer, 3/8" SAE Flat	F05011-3	2	
11	Nut, 3/8-16 Hex Nylon Lock	F05010-10	1	
	Roller Assembly, Blade Guide (standard for use with 1 1/4" & 1 1/2" blades)	A04925 <sup>2</sup>	1	
	Roller Assembly, Extended Blade Guide (optional for use with 1 1/2" blades)	014299 <sup>2</sup>	1	
	Bearing Kit, Blade Guide Rebuild	K07079	1	
12	Washer, 5/8" White Felt	P04252	1	
13	Ring, 1 1/8" Interior Retaining	F04254-1	1	
14	Bearing, R8-2RS Blade Guide	015975	2	◆
15	Washer, 5/8" Gray Felt	P06455	1	
	Screw, 1/4-28 x 1/4" Socket Head Cup Point Set Black Oxide	F05005-105	1	
	Instruction Sheet, Blade Guide Rebuild	057407-1507	1	
16	Roller, Flanged Blade Guide (1 1/4" & 1 1/2" blade)	S04250	1	◆
	Roller, Flanged Blade Guide (1 1/2" blade)	014298	1	◆
	Instruction Sheet, Blade Guide Roller Replacement	A04925-364	1	
17	Spacer, Blade Guide	S04253	2	
18	Washer, 1/2" Nord-Lock	F05011-125 <sup>3</sup>	1	
19	Bolt, 1/2-13 x 2 1/4" Hex Head Grade 5	F05008-10	1	
20	Washer, 5/16" SAE Flat	F05011-17	2	
21	Washer, 5/16" Split Lock	F05011-13	2	
22	Bolt, 5/16-18 x 1 1/2" Hex Head	F05006-76	2	
23	Bolt, Blade Guide Vertical Adjustment	035656	1	
24	Nut, 5/16-18 Hex	F05010-17	1	
25	Bolt, 5/16-18 x 2 3/4" Hex Head Full Thread	F05006-136	1	
	<b>GUIDE KIT, HIGH-PERFORMANCE BLADE GUIDE (OPTIONAL)</b>	006325 <sup>4</sup>	1	
	Block Assembly, Idle Side Blade Guide	003928	1	
26	Plate, Block Tilt Adjustment	003915	1	
27	Block, Guide Block Mount	003909	1	
28	Pin, 3/16" x 5/8" Roll	F05012-22	2	
29	Washer, 3/8" SAE Flat	F05011-3	1	
30	Washer, 3/8" Split Lock	F05011-4	1	
31	Bolt, 3/8-16 x 1 1/4" Hex Head Grade 5	F05007-123	1	
32	Bolt, 5/16-18 x 3/4" Hex Head w/Flat & Lock Washer	F05006-101	1	
33	Ball, 3/16" Dia. Nylon	003914	2	
34	Washer, 1/4" Split Lock	F05011-14	2	
35	Bolt, 1/4-20 x 1/2" Hex Head	F05005-15	2	
36	Bolt, Blade Guide Block Mount	003994	1	
37	Washer, #10 Brass	042867	1	
38	Bolt, #10-32 x 1 1/4" Hex Head Stainless Steel	F05004-240	1	
39	Screw, Lower Block Adjustment	044057	1	
40	Screw, #10-32 x 3/8" Socket Head Stainless Steel	F05004-200	1	
41	Washer, 5/16" SAE Flat	F05011-17	1	

# 2

## Blade Guide Rollers & Arm

### Blade Guide Assembly, Idle Side

42	Washer, 5/16" Split Lock	F05011-13	1	
43	Block, Blade Guide Wear (Standard for 1 1/4" Blades)	052355 <sup>5</sup>	2	
	Block, Blade Guide Wear (Optional for 1 1/2" Blades)	052309 <sup>5</sup>	2	
	Block Assembly, 1" Sq. EZ-Glide Wear	036347 <sup>5</sup>	2	
44	Block, Blade Guide Alignment	035799	1	
45	Washer, #10 Split Lock	F05011-20	1	
46	Screw, #10-32 x 5/8" Hex Head	F05004-152	1	
47	Adjustment Tool, Lower Guide Block	044064	1	
	Shim, .008" Blade Guide Block Spacer	035248	1	
Drive Side Blade Guide Parts ( <a href="#">See Section 2.1</a> )				
	<b>ROLLER ASSEMBLY, BLADE GUIDE RELUBE (OPTIONAL FOR USE WITH 1 1/4" OR 1 1/2" BLADES)</b>	016568 <sup>2</sup>	1	
	<b>ROLLER ASSEMBLY, EXTENDED BLADE GUIDE RELUBE (OPTIONAL FOR USE WITH 1 1/2" BLADES)</b>	057405 <sup>2</sup>	1	
	Bearing Kit, Relube Blade Guide Rebuild	057407	1	
48	Washer, 5/8" White Felt	P04252	1	
49	Ring, 1 1/8" Interior Retaining	F04254-1	1	
50	Bearing, R8-2RS Blade Guide	015975 <sup>6</sup>	2	◆
51	Washer, 5/8" Gray Felt	P06455	1	
52	Spacer, Blade Guide Bearing	035411	1	
	Instruction Sheet, Blade Guide Rebuild	057407-1507	1	
53	Roller, Flanged Blade Guide (Relube 1 1/4" & 1 1/2" blade)	035426	1	◆
	Roller, Flanged Blade Guide (Relube 1 1/2" blade)	057402	1	◆
	Instruction Sheet, Blade Guide Roller Replacement	A04925-364	1	
54	<b>BOLT, BLADE GUIDE ROLLER (RELUBE ONLY)</b>	036161	1	
55	<b>FITTING, 1/4-28 GREASE (RELUBE ONLY)</b>	P05060	1	

<sup>1</sup> Shaft Weldment 003924 modified to provide more clearance for adjustment bolts and to prevent water leaks (Rev. A5.02). New shaft requires two 1/16" NPT Pipe Plugs 007734.

<sup>2</sup> The sawmill is equipped standard with non-greasable blade guide rollers that can be used with the standard 1 1/4" blade or 1 1/2" blades. Optional extended blade guide rollers are available for use with 1 1/2" blades. The extended rollers may provide more stability during difficult sawing, but will reduce the total amount of times the blade can be reused after sharpening. Use kit 006382 to convert the rollers and guide blocks for both blade guides for 1 1/2" blades. Optional relube versions of each roller configuration are also available.

<sup>3</sup> Nord-Lock Washer F05011-125 replaced Split Lock Washer F05011-9 to prevent loosening due to vibration (Rev. A5.02).

<sup>4</sup> High-Performance Blade Guide Kit requires LMS blade lube system. Use kit 006325 to upgrade both drive and idle side blade guides to High-Performance. If sawmill not already equipped with LMS, add kit LMS-A.

<sup>5</sup> 052355 blocks for use with 1 1/4" blade provided as standard equipment. 052309 blocks available for optional use with 1 1/2" blades. Use kit 006382 to convert the rollers and guide blocks for both blade guides for 1 1/2" blades. EZ-Glide blocks 036347 are available for customers who prefer this block.

<sup>6</sup> Bearing must be modified for use with relube roller assemblies. Remove one seal from each bearing, place open sides facing each other and place spacer 035411 between bearings.



## 2.2 Blade Guide Assembly, Idle Side

LT50HD

Rev. A1.01 - A2.00

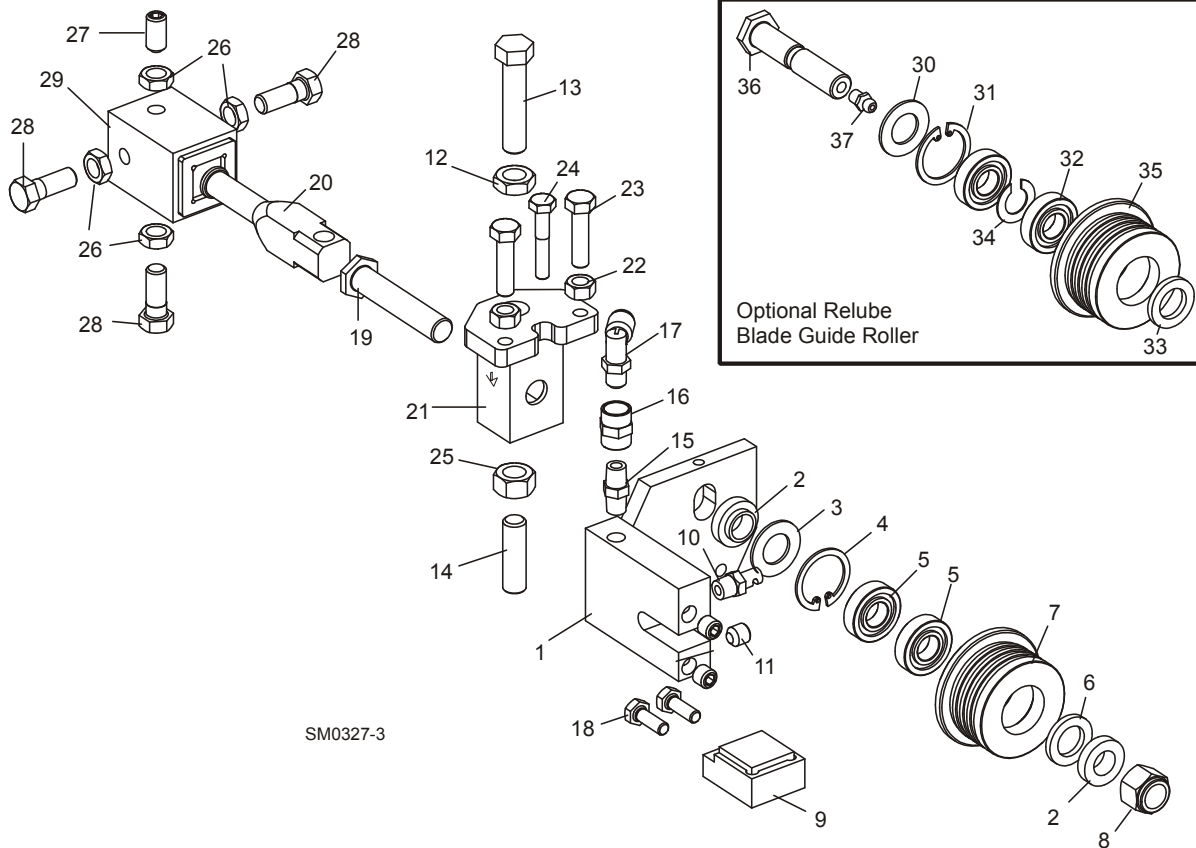

SM0327-3

REF	DESCRIPTION (◆ Indicates Parts Available In Assemblies Only)	PART #	QTY.
	<b>ROLLER/BLOCK ASSEMBLY, IDLE SIDE (OUTER)</b>	035405 <sup>1</sup>	1
1	Nozzle Block Weldment, Idle Side	035404	1
2	Spacer, .510 x .937 x .34	S04253	2
	Roller Assembly, Blade Guide (standard for use with 1 1/4" & 1 1/2" blades)	A04925 <sup>2</sup>	1
	Roller Assembly, Extended Blade Guide (optional for use with 1 1/2" blades)	014299 <sup>2</sup>	1
	Bearing Kit, Blade Guide Rebuild	K07079	1
3	Washer, 5/8" White Felt	P04252	1
4	Ring, 1 1/8" Interior Retaining	F04254-1	1
5	Bearing, R8-2RS Blade Guide	015975	2
6	Washer, 5/8" Gray Felt	P06455	1
	Screw, 1/4-28 x 1/4" Socket Head Cup Point Set Black Oxide	F05005-105	1
	Instruction Sheet, Blade Guide Rebuild	057407-1507	1
7	Roller, Flanged Blade Guide (1 1/4" & 1 1/2" blade)	S04250	1
	Roller, Flanged Blade Guide (1 1/2" blade)	014298	1

# 2

## Blade Guide Rollers & Arm

### Blade Guide Assembly, Idle Side

	Instruction Sheet, Blade Guide Roller Replacement	A04925-364	1	
8	Nut, 1/2-20 Nylon Hex Lock	F05010-15	1	
9	Block Assembly, 1 1/4" Blade EZ-Glide Wear	036247 <sup>3</sup>	1	
	Block, 1 1/4" Blade Guide Wear	052367 <sup>3</sup>	1	
	Block, 1 1/2" Blade Guide Wear	052366 <sup>3</sup>	1	
10	Nozzle, Blade Water Lube Spray (For use with standard bottle water lube)	016637 <sup>4</sup>	1	
11	Fitting, 1/8" NPT Socket Pipe Plug	P30127	3	
12	Nut, 7/16-20 Hex Jam	F05010-38 <sup>5</sup>	1	
13	Bolt, 7/16-20 x 2" Hex Head Full Thread Grade 8	F05007-215	1	
14	Screw, 7/16-20 x 1 1/2" Socket Head Flat Point Stainless Set	F05007-217 <sup>6</sup>	1	
15	Fitting, 1/8" Dry Seal Nipple	P02764	1	
16	Fitting, 1/8" FPT Coupling	P05748	1	
17	Fitting, 1/8" MPT x 1/4" Tube 90° Elbow Swivel	P09736	1	
18	Bolt, 1/4-20 x 3/4" Hex Head Grade 5	F05005-123	2	
19	Bolt, Blade Guide Roller	036374	1	
20	Shaft, Blade Guide Mount	054966	1	
21	Block, Roller Guide Adjuster	054969	1	
22	Nut, 5/16-24 Hex	F05010-28	2	
23	Bolt, 5/16-24 x 1 1/4" Hex Head Full Thread Grade 5	F05006-107	2	
24	Bolt, 1/4-28 x 1 1/2" Hex Head Grade 5	F05005-143	1	
25	Nut, 7/16-20 Hex	F05010-202	1	
	<b>SHIM, .008" BLADE GUIDE BLOCK SPACER</b>	035248	1	
26	<b>NUT, 3/8-24 HEX JAM</b>	F05010-22	4	
27	<b>SCREW, 3/8-24 X 3/4" STAINLESS STEEL SOCKET HEAD FLAT POINT</b>	F05007-95	1	
28	<b>BOLT, 3/8-24 X 1" STAINLESS STEEL HEX HEAD</b>	F05007-99	3	
29	<b>TUBE, BLADE GUIDE MOUNT</b> ( <a href="#">See Section 2.6</a> )	W08159	1	
	<b>ROLLER ASSEMBLY, BLADE GUIDE RELUBE (OPTIONAL FOR USE WITH 1 1/4" OR 1 1/2" BLADES)</b>	016568	1	
	<b>ROLLER ASSEMBLY, EXTENDED BLADE GUIDE RELUBE (OPTIONAL FOR USE WITH 1 1/2" BLADES)</b>	057405 <sup>2</sup>	1	
	Bearing Kit, Relube Blade Guide Rebuild	057407	1	
30	Washer, 5/8" White Felt	P04252	1	
31	Ring, 1 1/8" Interior Retaining	F04254-1	1	
32	Bearing, R8-2RS Blade Guide	015975 <sup>7</sup>	2	◆
33	Washer, 5/8" Gray Felt	P06455	1	
34	Spacer, Blade Guide Bearing	035411	1	
	Instruction Sheet, Blade Guide Rebuild	057407-1507	1	
35	Roller, Flanged Blade Guide (Relube 1 1/4" & 1 1/2" blade)	035426	1	◆
	Roller, Flanged Blade Guide (Relube 1 1/2" blade)	057402	1	◆
	Instruction Sheet, Blade Guide Roller Replacement	A04925-364	1	
36	<b>BOLT, BLADE GUIDE ROLLER (RELUBE ONLY)</b>	035412	1	
37	<b>FITTING, 1/4-28 GREASE (RELUBE ONLY)</b>	P05060	1	

- <sup>1</sup> New blade guide assembly available ([See Section 2.1](#)). Upgrade requires mounting arms, belt covers and LMS option. Use kit 006329 to retrofit (includes all parts necessary to retrofit both blade guide assemblies). If sawmill not already equipped with LMS option, add kit LMS-A.
- <sup>2</sup> The sawmill is equipped standard with non-greasable blade guide rollers that can be used with the standard 1 1/4" blade or 1 1/2" blades. Optional extended blade guide rollers are available for use with 1 1/2" blades. The extended rollers may provide more stability during difficult sawing, but will reduce the total amount of times the blade can be reused after sharpening. Optional relube versions of each roller configuration are also available.
- <sup>3</sup> Wear Block 052367 available 10/07 and provided as standard 4/09. EZ-Glide Block 036247 available for customers who prefer this block. Wear Block 052366 available for optional use with 1 1/2" blades.
- <sup>4</sup> Use two Blade Lube Fittings 033479 if sawmill is equipped with LubeMizer blade lube system. These fittings are supplied with the LMS option.
- <sup>5</sup> Lower jam nut F05010-38 replaced with hex nut F05010-202 (3/07).
- <sup>6</sup> Stainless Set Screw replaces Zinc plated screw F05007-213 used prior to 6/07 to eliminate screw shearing.
- <sup>7</sup> Bearing must be modified for use with relube roller assemblies. Remove one seal from each bearing, place open sides facing each other and place spacer 035411 between bearings.

# 2 Blade Guide Rollers & Arm

Blade Guide Assembly, Drive Side

## 2.3 Blade Guide Assembly, Drive Side

LT50HD

Rev. A2.01 - A5.02

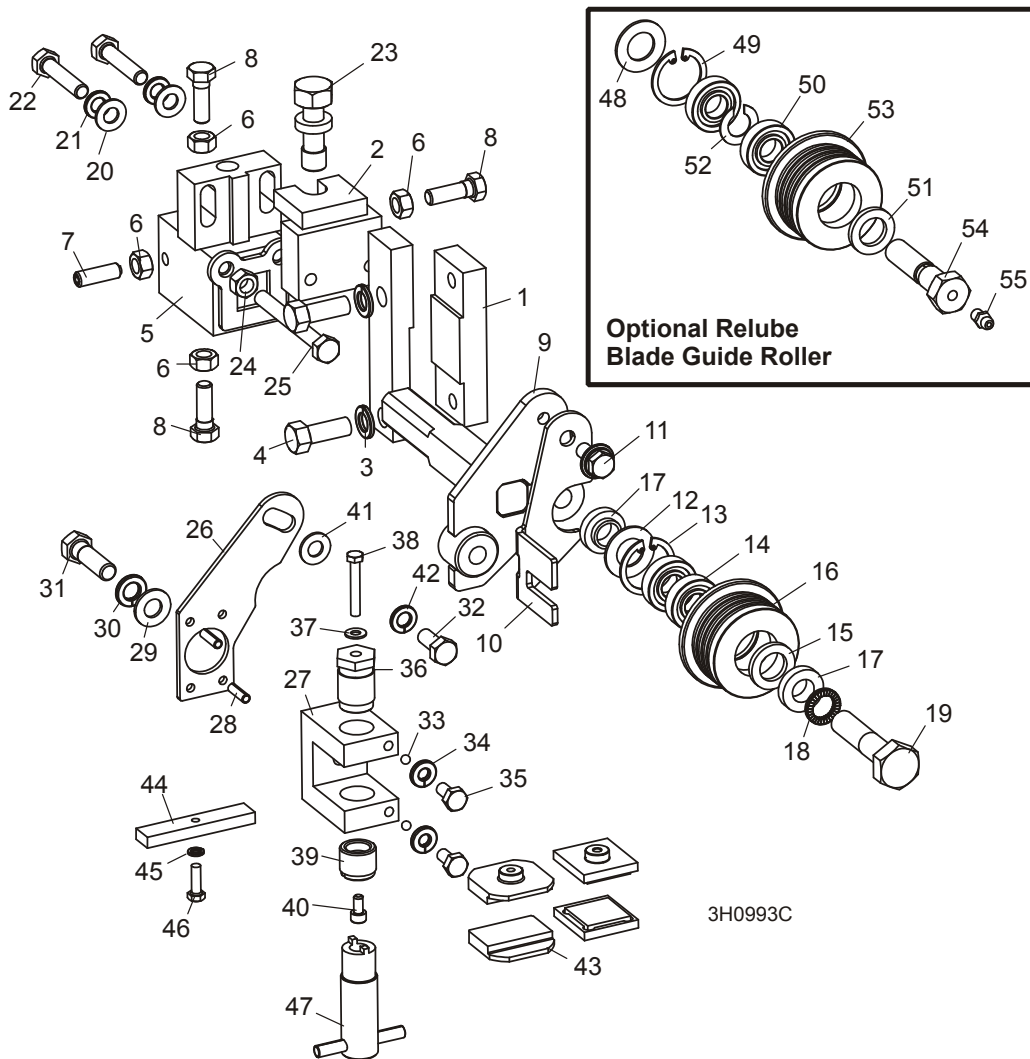

REF	DESCRIPTION (◆ Indicates Parts Available In Assemblies Only)	PART #	QTY.
1	BLOCK, BOLT ON BLADE GUIDE MOUNT	016548	1
2	BRACKET WELDMENT, INNER BLADE GUIDE MOUNT	003964	1
3	WASHER, 3/8" SPLIT LOCK	F05011-4	2
4	BOLT, 3/8-16 X 1" HEX HEAD	F05007-7	2
	GUIDE ASSEMBLY, DRIVE SIDE BLADE ROLLER	003905	1
	Block Assembly, Blade Guide Mount	003910	1
5	Block Weldment, Blade Guide Mount	003911	1
6	Nut, 5/16-18 Hex	F05010-17	4
7	Screw, 5/16-18 x 1" Socket Head Flat Point Stainless Steel Set	F05006-122	1

## Blade Guide Rollers & Arm

*Blade Guide Assembly, Drive Side*

2

8	Bolt, 5/16-18 x 1" Hex Head Stainless Steel	F05006-88	3	
9	Shaft Weldment, Drive Side Guide	003913	1	
10	Plate, Blade Guide Deflector	003916	1	
11	Bolt, 5/16-18 x 3/4" Hex Head w/Flat & Lock Washer	F05006-101	1	
	Roller Assembly, Blade Guide (standard for use with 1 1/4" & 1 1/2" blades)	A04925 <sup>1</sup>	1	
	Roller Assembly, Extended Blade Guide (optional for use with 1 1/2" blades)	014299 <sup>1</sup>	1	
	Bearing Kit, Blade Guide Rebuild	K07079	1	
12	Washer, 5/8" White Felt	P04252	1	
13	Ring, 1 1/8" Interior Retaining	F04254-1	1	
14	Bearing, R8-2RS Blade Guide	015975	2	◆
15	Washer, 5/8" Gray Felt	P06455	1	
	Screw, 1/4-28 x 1/4" Socket Head Cup Point Set Black Oxide	F05005-105	1	
	Instruction Sheet, Blade Guide Rebuild	057407-1507	1	
16	Roller, Flanged Blade Guide (1 1/4" & 1 1/2" blade)	S04250	1	◆
	Roller, Flanged Blade Guide (1 1/2" blade)	014298	1	◆
	Instruction Sheet, Blade Guide Roller Replacement	A04925-364	1	
17	Spacer, Blade Guide	S04253	2	
18	Washer, 1/2" Nord-Lock	F05011-125 <sup>2</sup>	1	
19	Bolt, 1/2-13 x 2 1/4" Hex Head Grade 5	F05008-10	1	
20	Washer, 5/16" SAE Flat	F05011-17	2	
21	Washer, 5/16" Split Lock	F05011-13	2	
22	Bolt, 5/16-18 x 1 1/2" Hex Head	F05006-76	2	
23	Bolt, Blade Guide Vertical Adjustment	035656	1	
24	Nut, 5/16-18 Hex	F05010-17	1	
25	Bolt, 5/16-18 x 2 3/4" Hex Head Full Thread	F05006-136	1	
	<b>GUIDE KIT, HIGH-PERFORMANCE BLADE GUIDE (OPTIONAL)</b>	006325 <sup>3</sup>	1	
	Block Assembly, Drive Side Blade Guide	003927	1	
26	Plate, Block Tilt Adjustment	003915	1	
27	Block, Guide Block Mount	003909	1	
28	Pin, 3/16" x 5/8" Roll	F05012-22	2	
29	Washer, 3/8" SAE Flat	F05011-3	1	
30	Washer, 3/8" Split Lock	F05011-4	1	
31	Bolt, 3/8-16 x 1 1/4" Hex Head Grade 5	F05007-123	1	
32	Bolt, 5/16-18 x 3/4" Hex Head w/Flat & Lock Washer	F05006-101	1	
33	Ball, 3/16" Dia. Nylon	003914	2	
34	Washer, 1/4" Split Lock	F05011-14	2	
35	Bolt, 1/4-20 x 1/2" Hex Head	F05005-15	2	
36	Bolt, Blade Guide Block Mount	003994	1	
37	Washer, #10 Brass	042867	1	
38	Bolt, #10-32 x 1 1/4" Hex Head Stainless Steel	F05004-240	1	
39	Screw, Lower Block Adjustment	044057	1	
40	Screw, #10-32 x 3/8" Socket Head Stainless Steel	F05004-200	1	
41	Washer, 5/16" SAE Flat	F05011-17	1	

# 2

## Blade Guide Rollers & Arm

### Blade Guide Assembly, Drive Side

42	Washer, 5/16" Split Lock	F05011-13	1	
43	Block, Blade Guide Wear (Standard for 1 1/4" Blades)	052355 <sup>4</sup>	2	
	Block, Blade Guide Wear (Optional for 1 1/2" Blades)	052309 <sup>4</sup>	2	
	Block Assembly, 1" Sq. EZ-Glide Wear	036347 <sup>4</sup>	2	
44	Block, Blade Guide Alignment	035799	1	
45	Washer, #10 Split Lock	F05011-20	1	
46	Screw, #10-32 x 5/8" Hex Head	F05004-152	1	
47	Adjustment Tool, Lower Guide Block	044064	1	
	Shim, .008" Blade Guide Block Spacer	035248	1	
Idle Side Blade Guide Parts ( <a href="#">See Section 2.1</a> )				
	<b>ROLLER ASSEMBLY, BLADE GUIDE RELUBE (OPTIONAL FOR USE WITH 1 1/4" OR 1 1/2" BLADES)</b>	016568 <sup>1</sup>	1	
	<b>ROLLER ASSEMBLY, EXTENDED BLADE GUIDE RELUBE (OPTIONAL FOR USE WITH 1 1/2" BLADES)</b>	057405 <sup>1</sup>	1	
	Bearing Kit, Relube Blade Guide Rebuild	057407	1	
48	Washer, 5/8" White Felt	P04252	1	
49	Ring, 1 1/8" Interior Retaining	F04254-1	1	
50	Bearing, R8-2RS Blade Guide	015975 <sup>5</sup>	2	◆
51	Washer, 5/8" Gray Felt	P06455	1	
52	Spacer, Blade Guide Bearing	035411	1	
	Instruction Sheet, Blade Guide Rebuild	057407-1507	1	
53	Roller, Flanged Blade Guide (Relube 1 1/4" & 1 1/2" blade)	035426	1	◆
	Roller, Flanged Blade Guide (Relube 1 1/2" blade)	057402	1	◆
	Instruction Sheet, Blade Guide Roller Replacement	A04925-364	1	
54	<b>BOLT, BLADE GUIDE ROLLER (RELUBE ONLY)</b>	036161	1	
55	<b>FITTING, 1/4-28 GREASE (RELUBE ONLY)</b>	P05060	1	

<sup>1</sup> The sawmill is equipped standard with non-greasable blade guide rollers that can be used with the standard 1 1/4" blade or 1 1/2" blades. Optional extended blade guide rollers are available for use with 1 1/2" blades. The extended rollers may provide more stability during difficult sawing, but will reduce the total amount of times the blade can be reused after sharpening. Use kit 006382 to convert the rollers and guide blocks for both blade guides for 1 1/2" blades. Optional relube versions of each roller configuration are also available.

<sup>2</sup> Nord-Lock Washer F05011-125 replaced Split Lock Washer F05011-9 to prevent loosening due to vibration (Rev. A5.02).

<sup>3</sup> High-Performance Blade Guide Kit requires LMS blade lube system. Use kit 006325 to upgrade both drive and idle side blade guides to High-Performance. If sawmill not already equipped with LMS, add kit LMS-A.

<sup>4</sup> 052355 blocks for use with 1 1/4" blade provided as standard equipment. 052309 blocks available for optional use with 1 1/2" blades. Use kit 006382 to convert the rollers and guide blocks for both blade guides for 1 1/2" blades. EZ-Glide blocks 036347 are available for customers who prefer this block.

<sup>5</sup> Bearing must be modified for use with relube roller assemblies. Remove one seal from each bearing, place open sides facing each other and place spacer 035411 between bearings.

## 2.4 Blade Guide Assembly, Drive Side

LT50HD

Rev. A1.01 - A2.00

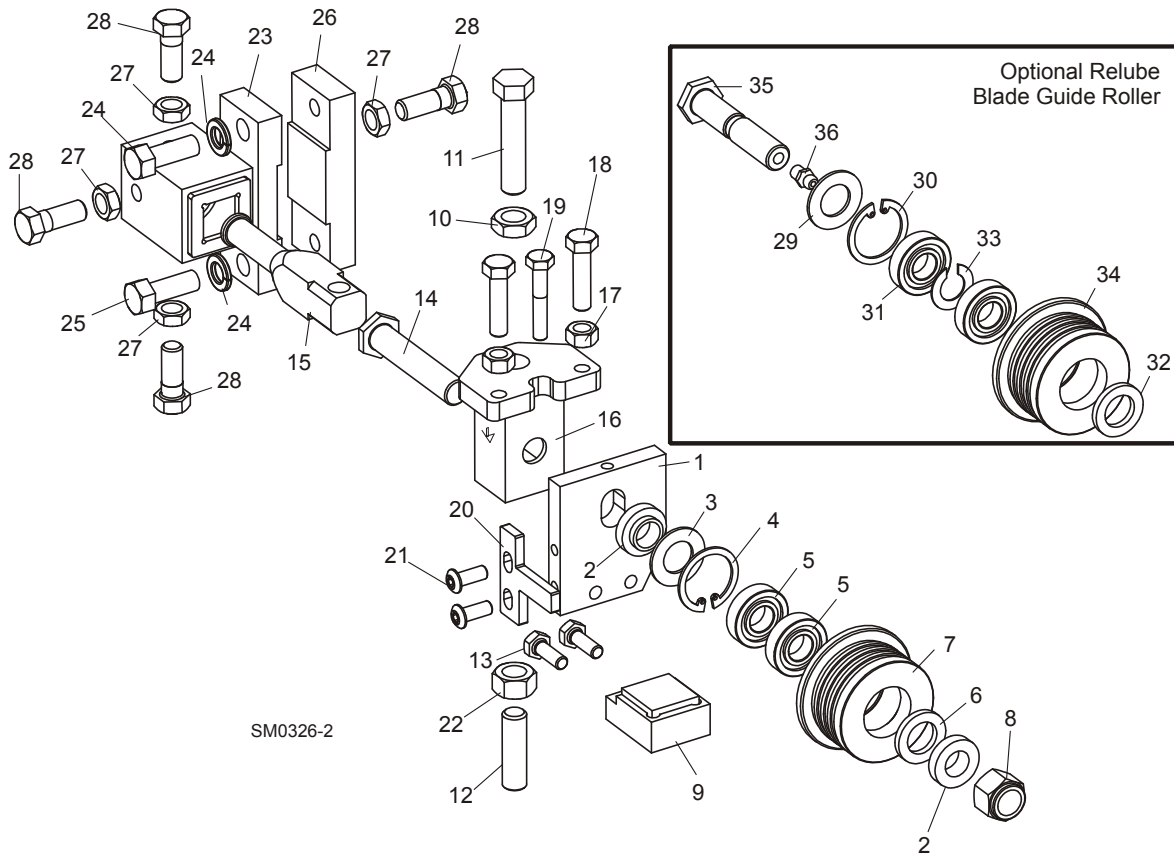

SM0326-2

REF	DESCRIPTION (◆ Indicates Parts Available In Assemblies Only)	PART #	QTY.
	<b>ROLLER/BLOCK ASSEMBLY, DRIVE SIDE (INNER)</b>	035410 <sup>1</sup>	1
1	Plate, Blade Guide Back Mounting	035409	1
2	Spacer, .510 x .937 x .34	S04253	2
	Roller Assembly, Blade Guide (standard for use with 1 1/4" & 1 1/2" blades)	A04925 <sup>2</sup>	1
	Roller Assembly, Extended Blade Guide (optional for use with 1 1/2" blades)	014299 <sup>2</sup>	1
	Bearing Kit, Blade Guide Rebuild	K07079	1
3	Washer, 5/8" White Felt	P04252	1
4	Ring, 1 1/8" Interior Retaining	F04254-1	1
5	Bearing, R8-2RS Blade Guide	015975	2
6	Washer, 5/8" Gray Felt	P06455	1
	Screw, 1/4-28 x 1/4" Socket Head Cup Point Set Black Oxide	F05005-105	1
	Instruction Sheet, Blade Guide Rebuild	057407-1507	1

# 2

## Blade Guide Rollers & Arm

### Blade Guide Assembly, Drive Side

7	Roller, Flanged Blade Guide (1 1/4" & 1 1/2" blade)	S04250	1	◆
	Roller, Flanged Blade Guide (1 1/2" blade)	014298	1	◆
	Instruction Sheet, Blade Guide Roller Replacement	A04925-364	1	
8	Nut, 1/2-20 Nylon Hex Lock	F05010-15	1	
9	Block Assembly, 1 1/4" Blade EZ-Glide Wear	036247 <sup>3</sup>	1	
	Block, 1 1/4" Blade Guide Wear	052367 <sup>3</sup>	1	
	Block, 1 1/2" Blade Guide Wear	052366 <sup>3</sup>	1	
10	Nut, 7/16-20 Hex Jam	F05010-38 <sup>4</sup>	1	
11	Bolt, 7/16-20 x 2" Hex Head Full Thread Grade 8	F05007-215	1	
12	Screw, 7/16-20 x 1 1/2" Socket Head Flat Point Stainless Set	F05007-217 <sup>5</sup>	1	
13	Bolt, 1/4-20 x 3/4" Hex Head Grade 5	F05005-123	2	
14	Bolt, Blade Guide Roller	036374	1	
15	Shaft, Blade Guide Mount	054966	1	
16	Block Weldment, Roller Guide Adjuster	054969	1	
17	Nut, 5/16-24 Hex	F05010-28	2	
18	Bolt, 5/16-24 x 1 1/4" Hex Head Full Thread Stainless	F05006-107	2	
19	Bolt, 1/4-28 x 1 1/2" Hex Head Stainless	F05005-143	1	
20	Guard, Drive Roller	035490	1	
21	Screw, 1/4-20 x 55/8" Button Head Socket Cap Grade 2	F05005-128	2	
22	Nut, 7/16-20 Hex	F05010-202 <sup>4</sup>	1	
	<b>SHIM, .008" BLADE GUIDE BLOCK SPACER</b>	035248	1	
	<b>BLOCK KIT, DRIVE SIDE BLADE GUIDE BOLT ON</b>	016566	1	
23	Block Weldment, Drive Side Blade Guide Bolt On	016550	1	
24	Washer, 3/8" Split Lock	F05011-4	2	
25	Bolt, 3/8-16 x 1" Hex Head	F05007-7	2	
26	Block, Bolt On Blade Guide Mount	016548	1	
27	Nut, 3/8-24 Jam	F05010-22	4	
28	Bolt, 3/8-24 X 1" Stainless Steel Hex Head	F05007-99	4	
	<b>ROLLER ASSEMBLY, BLADE GUIDE RELUBE (OPTIONAL FOR USE WITH 1 1/4" OR 1 1/2" BLADES)</b>	016568 <sup>2</sup>	1	
	<b>ROLLER ASSEMBLY, EXTENDED BLADE GUIDE RELUBE (OPTIONAL FOR USE WITH 1 1/2" BLADES)</b>	057405 <sup>2</sup>	1	
	Bearing Kit, Relube Blade Guide Rebuild	057407	1	
29	Washer, 5/8" White Felt	P04252	1	
30	Ring, 1 1/8" Interior Retaining	F04254-1	1	
31	Bearing, R8-2RS Blade Guide	015975 <sup>6</sup>	2	◆
32	Washer, 5/8" Gray Felt	P06455	1	
33	Spacer, Blade Guide Bearing	035411	1	
	Instruction Sheet, Blade Guide Rebuild	057407-1507	1	
34	Roller, Flanged Blade Guide (Relube 1 1/4" & 1 1/2" blade)	035426	1	◆
	Roller, Flanged Blade Guide (Relube 1 1/2" blade)	057402	1	◆
	Instruction Sheet, Blade Guide Roller Replacement	A04925-364	1	
35	<b>BOLT, BLADE GUIDE ROLLER (RELUBE ONLY)</b>	035412	1	



<b>36</b>	<b>FITTING, 1/4-28 GREASE (RELUBE ONLY)</b>	P05060	1	
-----------	---	--------	---	--

- <sup>1</sup> New blade guide assembly available ([See Section 2.3](#)). Upgrade requires mounting arms, belt covers and LMS option. Use kit 006329 to retrofit (includes all parts necessary to retrofit both blade guide assemblies). If sawmill not already equipped with LMS option, add kit LMS-A.
- <sup>2</sup> The sawmill is equipped standard with non-greasable blade guide rollers that can be used with the standard 1 1/4" blade or 1 1/2" blades. Optional extended blade guide rollers are available for use with 1 1/2" blades. The extended rollers may provide more stability during difficult sawing, but will reduce the total amount of times the blade can be reused after sharpening. Optional relube versions of each roller configuration are also available.
- <sup>3</sup> Wear Block 052367 available 10/07 and provided as standard 4/09. EZ-Glide Block 036247 available for customers who prefer this block. Wear Block 052366 available for optional use with 1 1/2" blades.
- <sup>4</sup> Lower jam nut F05010-38 replaced with hex nut F05010-202 (3/07).
- <sup>5</sup> Stainless Set Screw replaces Zinc plated screw F05007-213 used prior to 6/07 to eliminate screw shearing.
- <sup>6</sup> Bearing must be modified for use with relube roller assemblies. Remove one seal from each bearing, place open sides facing each other and place spacer 035411 between bearings.

## 2 Blade Guide Rollers & Arm

### Blade Guide Arm Drive Assembly

## 2.5 Blade Guide Arm Drive Assembly

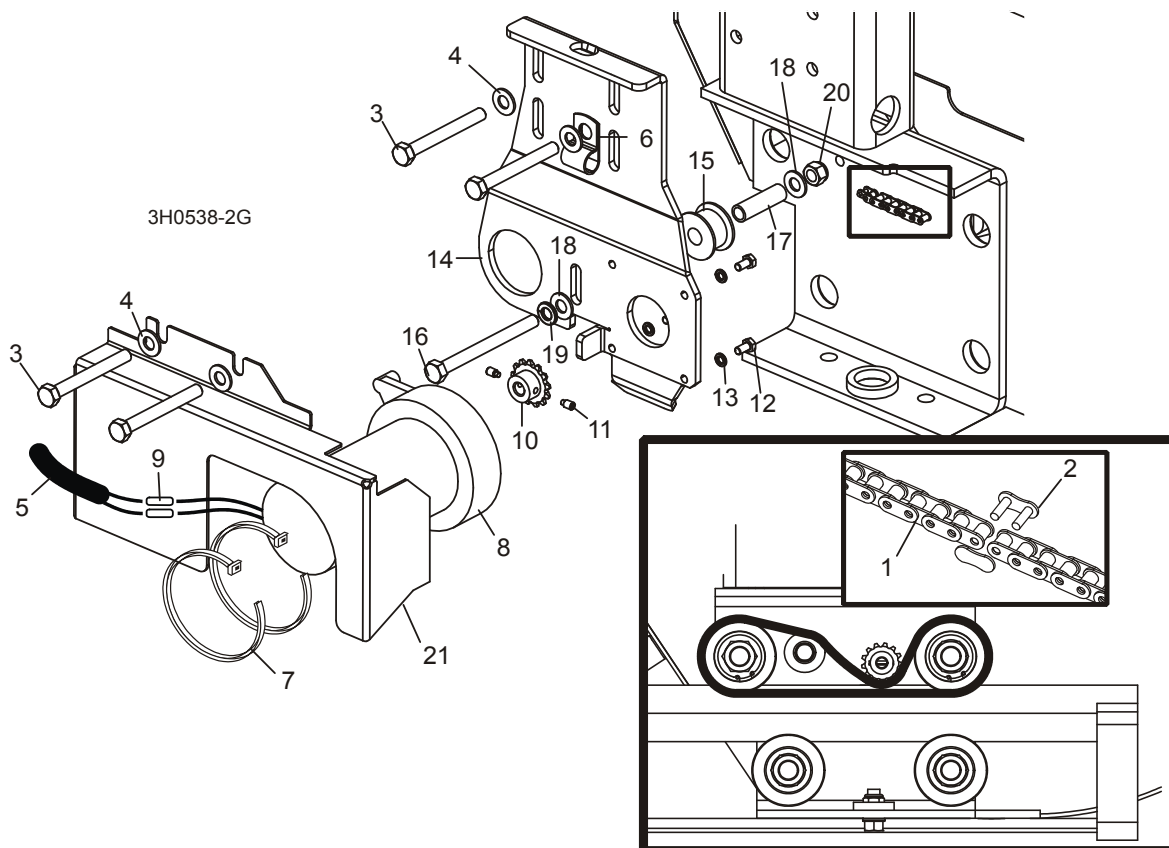

REF	DESCRIPTION (◆ Indicates Parts Available In Assemblies Only)	PART #	QTY.
1	CHAIN, #25 X 20 1/4"	P09984	1
2	LINK, #25 MASTER	P09983	1
3	BOLT, 5/16-18 X 2 3/4" HEX HEAD GRADE 5	F05006-28	4
4	WASHER, 5/16" SAE FLAT	F05011-17	4
5	TUBE, 3/8" X 1/2" NEOPRENE	R01897	2.5ft
6	CLAMP, 1/2" COATED EMT	P07584	2
7	WRAP, 1/4" X 6" TIE	F05089-1	2
	<b>DRIVE ASSEMBLY, BLADE GUIDE ARM</b>	015989	1
	Motor Assembly, Blade Guide Arm Replacement	A10353	1
8	Motor, Blade Guide Arm 53:1 Gear	P09698-1	1
	Housing, Klauber Motor End	P12756	1
	Gear Kit, Klauber Motor Replacement	P12569	1
	Brush Kit, Gear Motor Replacement	P12800	1
	Shaft Kit, Klauber Gear Motor Replacement	009695	1
9	Connector, 14 Gauge Butt	F04875-1	2
10	Sprocket, Gear Motor #25 14-Tooth	P09970 <sup>1</sup>	1
11	Screw, #10-24 x 1/4" Full Dog Point Socket Set	F05004-274	2

## Blade Guide Rollers & Arm

*Blade Guide Arm Drive Assembly*

2

12	Screw, #10-32 x 1/2" Hex Head	F05004-60	4	
13	Washer, #10 Split Lock	F05011-20	4	
	Instruction Sheet, Blade Guide Arm Motor	A10365-296	1	
14	Bracket, Blade Guide Arm Motor Mount	015939	1	
15	Roller, Blade Guide Arm Chain Idler	S09999	1	
16	Bolt, 5/16-18 X 3 1/2" Hex Head Full Thread	F05006-3	1	
17	Spacer, 5/16" I.D. X 1 1/2"	S09996	1	
18	Washer, 5/16" SAE Flat	F05011-17	2	
19	Washer, 5/16" Split Lock	F05011-13	1	
20	Nut, 5/16-18 Hex Nylon Lock	F05010-58	1	
21	<b>COVER, BLADE GUIDE ARM MOTOR</b>	S11617	1	
	<b>GUARD, BLADE GUIDE ARM (G.S. ONLY)</b>	S12029	1	

<sup>1</sup> Sprocket modified 6/11 with threaded holes to accept included set screws (replace 1/8" x 3/4" roll pin F05012-6).

## 2 Blade Guide Rollers & Arm

### Blade Guide Arm

### 2.6 Blade Guide Arm

LT50HD

Rev. A2.01 - A5.02

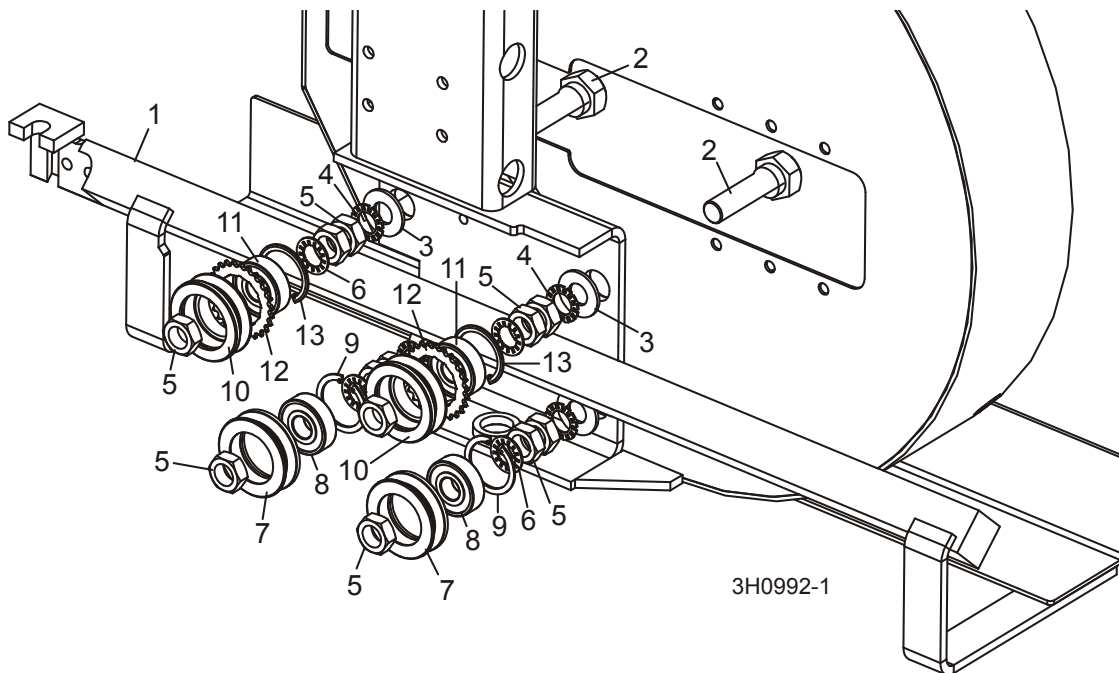

REF	DESCRIPTION (◆ Indicates Parts Available In Assemblies Only)	PART #	QTY.	
1	<b>BLADE GUIDE ARM WELDMENT</b>	003972	1	
2	<b>BOLT, BLADE GUIDE ARM ROLLER CAM</b>	W09067	4	
3	<b>WASHER, 5/8" SAE FLAT</b>	F05011-5	4	
4	<b>WASHER, 5/8" EXTERNAL STAR</b>	F05011-26	4	
5	<b>NUT, 5/8-18 HEX JAM</b>	F05010-11	12	
6	<b>WASHER, 5/8" INTERNAL STAR</b>	F05011-25	8	
	<b>ROLLER ASSEMBLY, BLADE GUIDE ARM WITH BEARING</b>	A09059	2	
7	Roller, Blade Guide Arm V-Groove	S07989	1	◆
8	Bearing, 6203-2NSL 5/8" I.D.	P06030-1	1	◆
9	Ring, 1.575" ID Beveled 5002-156 Retaining	F04254-8	1	
	<b>ROLLER ASSEMBLY, BLADE GUIDE ARM WITH BEARING AND SPROCKET</b>	A09932	2	
10	Roller, Blade Guide Arm Drive	S09930	1	◆
11	Bearing, 6203-2NSL 5/8" I.D.	P06030-1	1	◆
12	Sprocket, #25 26-Tooth	S09931	1	◆
13	Ring, 1.575" ID Beveled 5002-156 Retaining	F04254-8	1	

## 2.7 Blade Guide Arm

LT50HD

Rev. A1.01 - A2.00

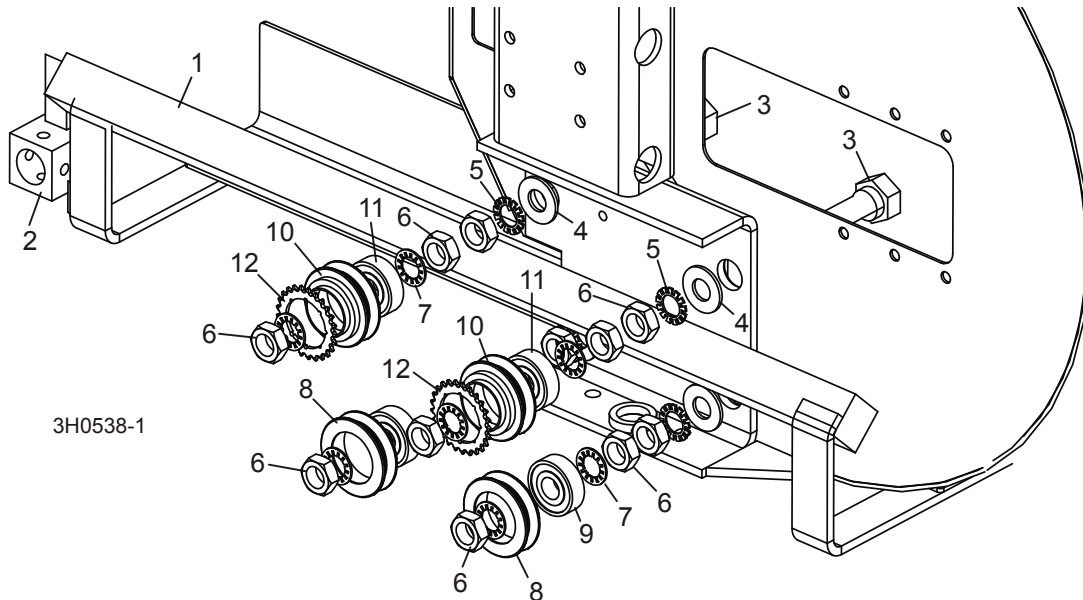

REF	DESCRIPTION (◆ Indicates Parts Available In Assemblies Only)	PART #	QTY.	
1	BLADE GUIDE ARM WELDMENT (U.S. 28 5/8" [72.7 CM])	W10005	1	
	BLADE GUIDE ARM WELDMENT (G.S. 37 1/8" [94.2 CM])	W10429	1	
2	Tube, Blade Guide Mount (U.S. - Welded to Blade Guide Arm)	W08159	1	
	Tube, Blade Guide Mount (G.S. - Bolted to Blade Guide Arm)	W10426	1	
3	BOLT, BLADE GUIDE ARM ROLLER CAM	W09067	4	
4	WASHER, 5/8" SAE FLAT	F05011-5	4	
5	WASHER, 5/8" EXTERNAL STAR	F05011-26	4	
6	NUT, 5/8-18 HEX JAM	F05010-11	12	
7	WASHER, 5/8" INTERNAL STAR	F05011-25	8	
	<b>ROLLER ASSEMBLY, BLADE GUIDE ARM WITH BEARING</b>	A09059	2	
8	Roller, Blade Guide Arm V-Groove	S07989	1	◆
9	Bearing, 6203-2NSL 5/8" I.D.	P06030-1	1	◆
	Ring, 1.575" ID Beveled 5002-156 Retaining	F04254-8	1	
	<b>ROLLER ASSEMBLY, BLADE GUIDE ARM WITH BEARING AND SPROCKET</b>	A09932	2	
10	Roller, Blade Guide Arm Drive	S09930	1	◆
11	Bearing, 6203-2NSL 5/8" I.D.	P06030-1	1	◆
12	Sprocket, #25 26-Tooth	S09931	1	◆
	Ring, 1.575" ID Beveled 5002-156 Retaining	F04254-8	1	

## SECTION 3 BLADE WHEELS & TENSIONER

### 3.1 Blade Drive Assembly

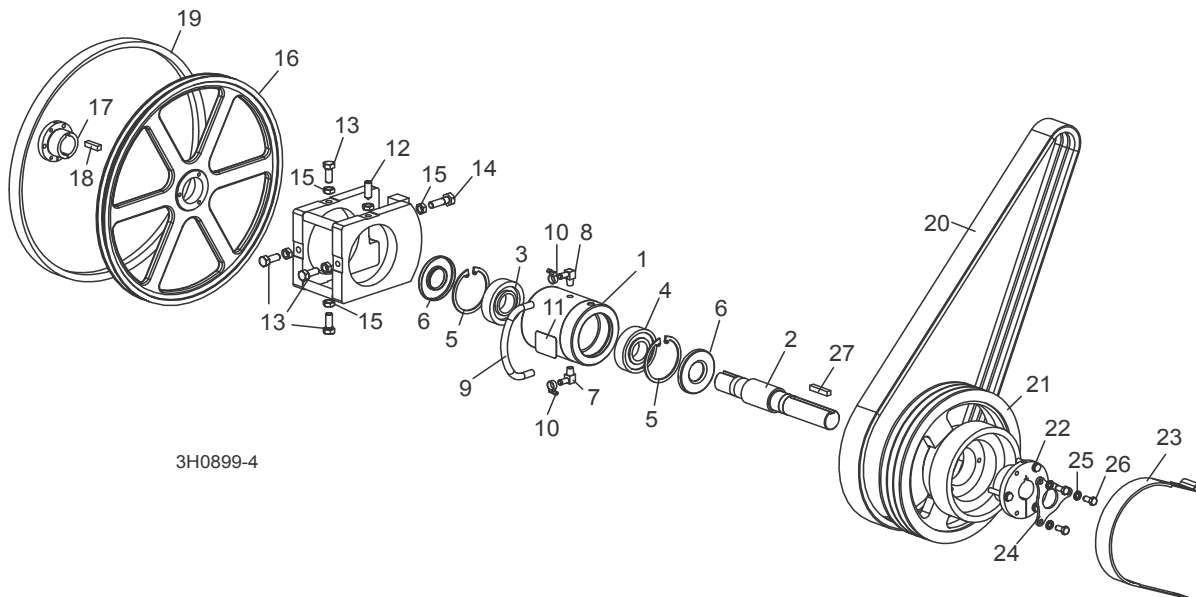

REF	DESCRIPTION (◆ Indicates Parts Available In Assemblies Only)	PART #	QTY.	
	<b>BEARING ASSEMBLY, BLADE WHEEL DRIVE</b>	016393	1	
	Bearing Assembly, Cylindrical Drive	016392	1	◆
1	Housing, Blade Wheel Drive Bearing	016391	1	◆
2	Shaft, Blade Wheel Drive	014005	1	◆
3	Bearing, Blade Wheel Drive #MU1308TV	P10205	1	◆
4	Bearing, Blade Wheel Drive #6308 C3 Open	016055	1	◆
5	Ring, 90mm Interior Retaining #I17	F04254-17	2	
6	Seal, Drive Bearing #CR15890	P10206-K	2	
7	Fitting, 1/4" NPT x 3/8" Hose Barb Elbow	016330	1	
8	Fitting, 1/4" NPT x 3/8" Hose Barb Vented Elbow	016331	1	
9	Hose, Oil Level Viewer	016394	1	
10	Clamp, 7/32-5/8" Hose	P649	2	
11	Decal, Oil Level Gauge	017470	1	
	Instruction Sheet, Drive Bearing Replacement	016393-555	1	
12	<b>SCREW, 1/2-20 X 1 1/2" CONE POINT SET</b>	F05004-170	1	
13	<b>BOLT, 1/2-20 X 1 1/4" HEX HEAD GRADE 5</b>	F05008-108	4	
14	<b>BOLT, 1/2-20 X 1 3/4" HEX HEAD GRADE 5</b>	F05008-49	1	
15	<b>NUT, 1/2-20 HEX JAM</b>	F05010-16	6	
	<b>WHEEL KIT, DRIVE SIDE BLADE</b>	014562	1	

# Blade Wheel & Tensioner

## *Blade Drive Assembly*

3

16	Wheel, Drive Side Blade	016284	1	◆
17	Bushing, Modified 1 9/16" SD	016270	1	
18	Key, 3/8" x 3/8" x 1 5/8"	S12892	1	
	Instruction Sheet, Drive Side Blade Wheel Replacement	K12897-488	1	
19	<b>BELT, BLADE WHEEL B57</b>	P04185	1	
20	<b>BELT, 3/5VL750 DRIVE (G38/E25 60HZ)</b>	006672 <sup>1</sup>	1	
	<b>BELT, 3/5VL770 DRIVE (D47/D51)</b>	046571	1	
	<b>BELT, 3/5VL760 DRIVE (E25 50HZ <sup>2</sup>)</b>	016557	1	
21	<b>SHEAVE, 5V12.5X3 BRAKE COMBO</b>	016531	1	
22	<b>BUSHING, SF X 1 9/16"</b>	016532	1	
23	<b>STRAP, METAL-BACKED BRAKE</b>	014391	1	
24	<b>PLATE, BUSHING KEY RETAINER</b>	017953	1	
25	<b>WASHER, 3/8" SPLIT LOCK</b>	F05011-4	3	
26	<b>BOLT, 3/8-16 X 3/4" HEX HEAD</b>	F05007-27	3	
27	<b>KEY, 3/8" X 3/8" X 1 7/8"</b>	014693	1	

<sup>1</sup> Cog-style belt 006672 replaces 016556 originally supplied prior to Rev. A2.02 to reduce slippage.

<sup>2</sup> Alternate parts for 50Hz Electric operation. Complete conversion kit available (Part Number 015863).

# 3 Blade Wheels & Tensioner

## Idle Blade Wheel Assembly

### 3.2 Idle Blade Wheel Assembly

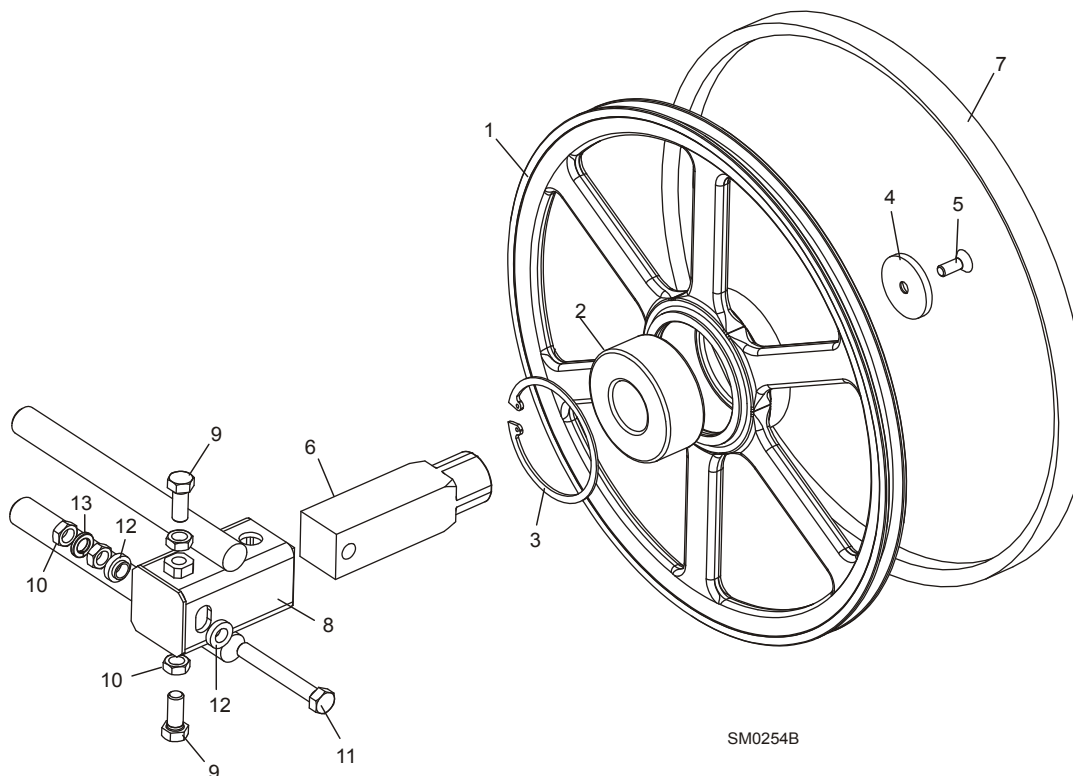

REF	DESCRIPTION (◆ Indicates Parts Available In Assemblies Only)	PART #	QTY.	
	<b>WHEEL ASSEMBLY, IDLE SIDE BLADE</b>	016120	1	
1	Wheel, Idle Side Blade	016013	1	◆
2	Bearing, Idle Side Blade Wheel #5309-2RS, C3, SRI-2 Grease	016014	1	
3	Ring, 100mm Internal Retaining Beveled	F04254-28	1	
	<b>SHAFT KIT, IDLE BLADE WHEEL</b>	016441	1	
4	Washer, 13/32" I.D. x 2 3/16 O.D. x 1/4"	016397	1	
5	Bolt, 3/8-16 x 1" Flat Head Socket	F05007-64	1	
6	Shaft, Idle Side Blade Wheel	016398	1	
7	<b>BELT, BLADE WHEEL B57</b>	P04185	1	
8	<b>HOUSING, IDLE BLADE WHEEL SHAFT</b>	016103	1	
9	<b>BOLT, 1/2-20 X 1 1/2" HEX HEAD GRADE 5</b>	F05008-53 <sup>1</sup>	2	
10	<b>NUT, 1/2-20 HEX JAM</b>	F05010-16	4	
11	<b>BOLT, 1/2-20 X 3 3/4" HEX HEAD FULL THREAD GRADE 2</b>	F05008-111	1	
12	<b>SPACER, 1/2" I.D. FLANGED</b>	S04253	2	
13	<b>WASHER, 1/2" SPLIT LOCK</b>	F05011-9	1	

<sup>1</sup> Replaces 1 1/4" Bolt F05008-108 originally supplied to allow for more tilt adjustment. Requires trimming of blade guide arm drive cover and mount channel to provide clearance for longer bolt (LT50 Rev. A1.02).



### 3.3 Hydraulic Blade Tensioner Assembly

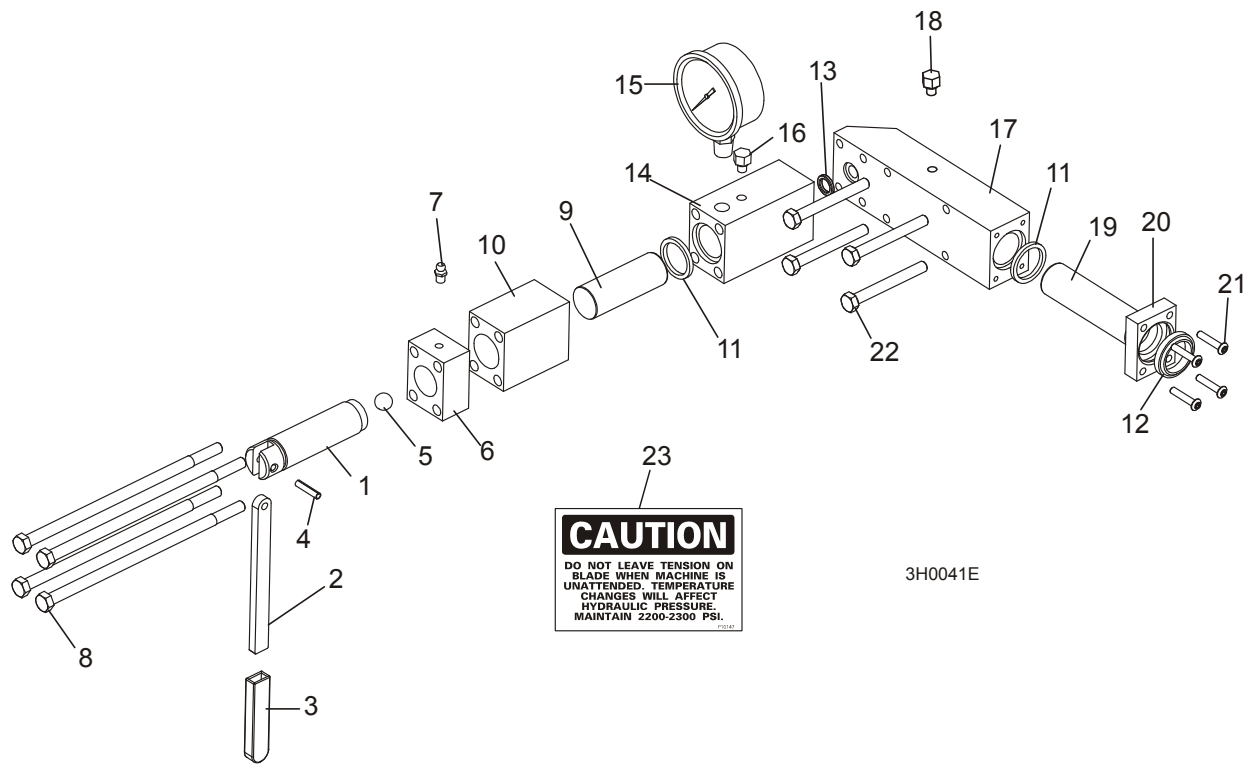

**CAUTION**  
DO NOT LEAVE TENSION ON  
BLADE WHEN MACHINE IS  
UNATTENDED. TEMPERATURE  
CHANGES WILL AFFECT  
HYDRAULIC PRESSURE.  
MAINTAIN 2200-2300 PSI.

3H0041E

REF	DESCRIPTION (◆ Indicates Parts Available In Assemblies Only)	PART #	QTY.	
	<b>HYDRAULIC BLADE TENSIONER ASSEMBLY</b>	A10136	1	
	Handle Assembly, Hydraulic Blade Tensioner Screw	A12294	1	
1	Screw, Hydraulic Blade Tensioner	S10056	1	◆
2	Handle, Hydraulic Tensioner Screw	S08174	1	
3	Sleeve, Plastic Handle	P08072	1	
4	Pin, 3/16" x 7/8" Roll	F05012-19	1	
5	Ball, 1/2" Steel	P02720	1	
6	Block, Threaded Tensioner End	S10062	1	◆
7	Fitting, 1/4-28 Grease	P05060	1	
	Instruction Sheet, Tensioner Screw	A12294-518	1	
8	Bolt, 5/16-18 X 7 1/2" Hex Head Grade 5	F05006-43	4	
9	Piston, Hydraulic Tensioner Front 2 3/4" Long	S10060	1	
10	Block, Piston Guide	S10061	1	
	Seal Kit, Hydraulic Tensioner	003224	1	
5	Ball, 1/2" Steel	P02720	1	
11	Seal, 1" Diameter	P10051	2	
12	Wiper, 1" Diameter	P10053	1	
13	Ring, 5/8" X 3/32" Square "O"	P10377	1	

# 3

## Blade Wheels & Tensioner

### Hydraulic Blade Tensioner Assembly

14	Block, Hydraulic Tensioner Gauge Mounting	S10140	1	
15	Gauge, 5000 P.S.I.	P10052	1	
16	Plug, Hydraulic Tensioner Fill	P10065	1	
	Block Assembly, Rear Tensioner Piston	016329	1	
17	Block, Rear Tensioner Piston	S10142	1	◆
18	Plug, Hydraulic Tensioner Fill	P10065	1	
19	Piston, Hydraulic Tensioner Rear 3 5/8" Long	S10059	1	
20	Block, Rear Piston End	S10089	1	
21	Bolt, #10-24 X 1" Socket Button Head	F05004-43	4	
22	Bolt, 5/16-18 X 2 3/4" Hex Head Grade 5	F05006-28	4	
23	Decal, Hydraulic Tension Caution	P10147	1	
	Instruction Sheet, Hydraulic Tensioner Installation	A10136-272	1	

## SECTION 4 SAW HEAD

### 4.1 Middle Throat Screw

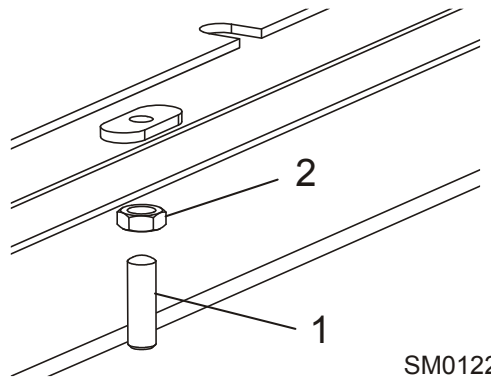

REF	DESCRIPTION (◆ Indicates Parts Available In Assemblies Only)	PART #	QTY.	
1	SCREW, 3/8-16 X 1 1/4" OVAL POINT SOCKET SET	F05007-18	1	
2	NUT, 3/8-16 HEX JAM	F05010-29	1	

# 4 Saw Head

## Water Lube Solenoid Valve

### 4.2 Water Lube Solenoid Valve

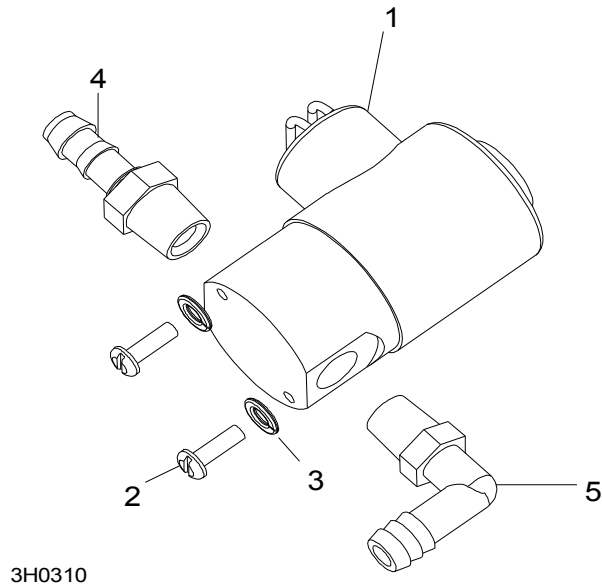

REF	DESCRIPTION (◆ Indicates Parts Available In Assemblies Only)	PART #	QTY.	
	<b>VALVE KIT, WATER LUBE SOLENOID</b>	016280	1	
1	Valve, Water Lube Solenoid	016140	1	◆
2	Screw, #10-32 x 1/2" Slotted Round Head	F05004-55	2	
3	Washer, #10 Split Lock	F05011-20	2	
4	<b>FITTING, 1/4" MALE NPT 3/8" HOSE BARB</b>	P04682	1	
5	<b>FITTING, 1/4" MALE NPT 3/8" HOSE BARB ELBOW</b>	P04730	1	

### 4.3 Clutch Mount Assembly

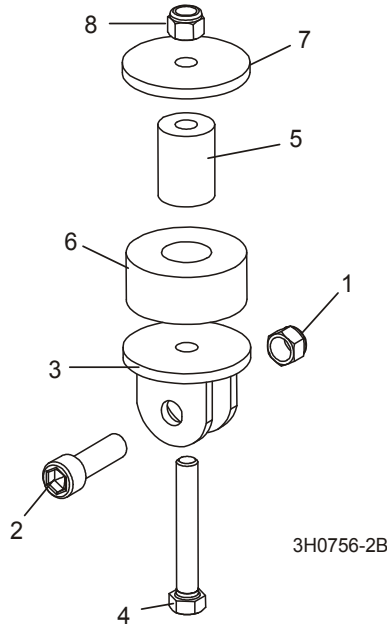

REF	DESCRIPTION (◆ Indicates Parts Available In Assemblies Only)	PART #	QTY.	
1	NUT, 7/16-20 HEX NYLON LOCK	F05010-83	1	
2	BOLT, 7/16-20 X 1 1/2" SOCKET HEAD	F05007-55	1	
3	BRACKET, CLUTCH MOUNT	W12411	1	
4	BOLT, 3/8-16 X 2 1/2" HEX HEAD	F05007-157	1	
5	SPACER, MOTOR MOUNT VIBRATION BUSHING	016316	1	
6	BUSHING, MOTOR MOUNT VIBRATION	P05032	1	
7	WASHER, .40" I.D. X 1.44" O.D. X .18" THICK	021276	1	
8	NUT, 3/8-16 NYLON LOCK	F05010-10	1	

# 4 Saw Head

## Brake Assembly

### 4.4 Brake Assembly

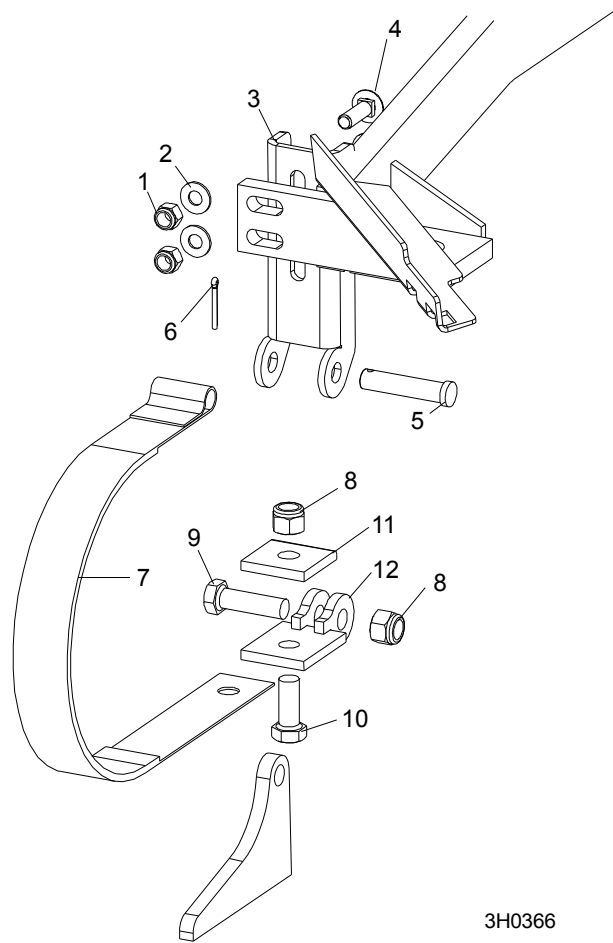

3H0366

REF	DESCRIPTION (◆ Indicates Parts Available In Assemblies Only)	PART #	QTY.
	<b>STRAP RETROFIT, SUPER BRAKE</b>	014441	1
1	Nut, 3/8-16 Nylon Lock	F05010-10	2
2	Washer, 3/8" SAE Flat	F05011-3	2
3	Bracket, Upper Super Brake Strap Mount	014395	1
4	Bolt, 3/8-16 x 1 1/4" Carriage Head Grade 5	F05007-127	2
5	Pin, 1/2" x 2 1/4" Clevis	F05012-81	1
6	Pin, 1/8" x 1" Cotter	F05012-1	1
7	Strap, Upper Pivot Metal Brake	014391	1
8	Nut, 1/2-13 Nylon Lock	F05010-8	2
9	Bolt, 1/2-13 x 1 3/4" Hex Head Grade 5	F05008-88	1
10	Bolt, 1/2-13 x 1 1/4" Hex Head Grade 5	F05008-37	1
11	Plate, Brake Strap Clamp	S04195	1
12	Bracket, Lower Super Brake Strap Mount	014392	1

### 4.5 Board Return Assembly

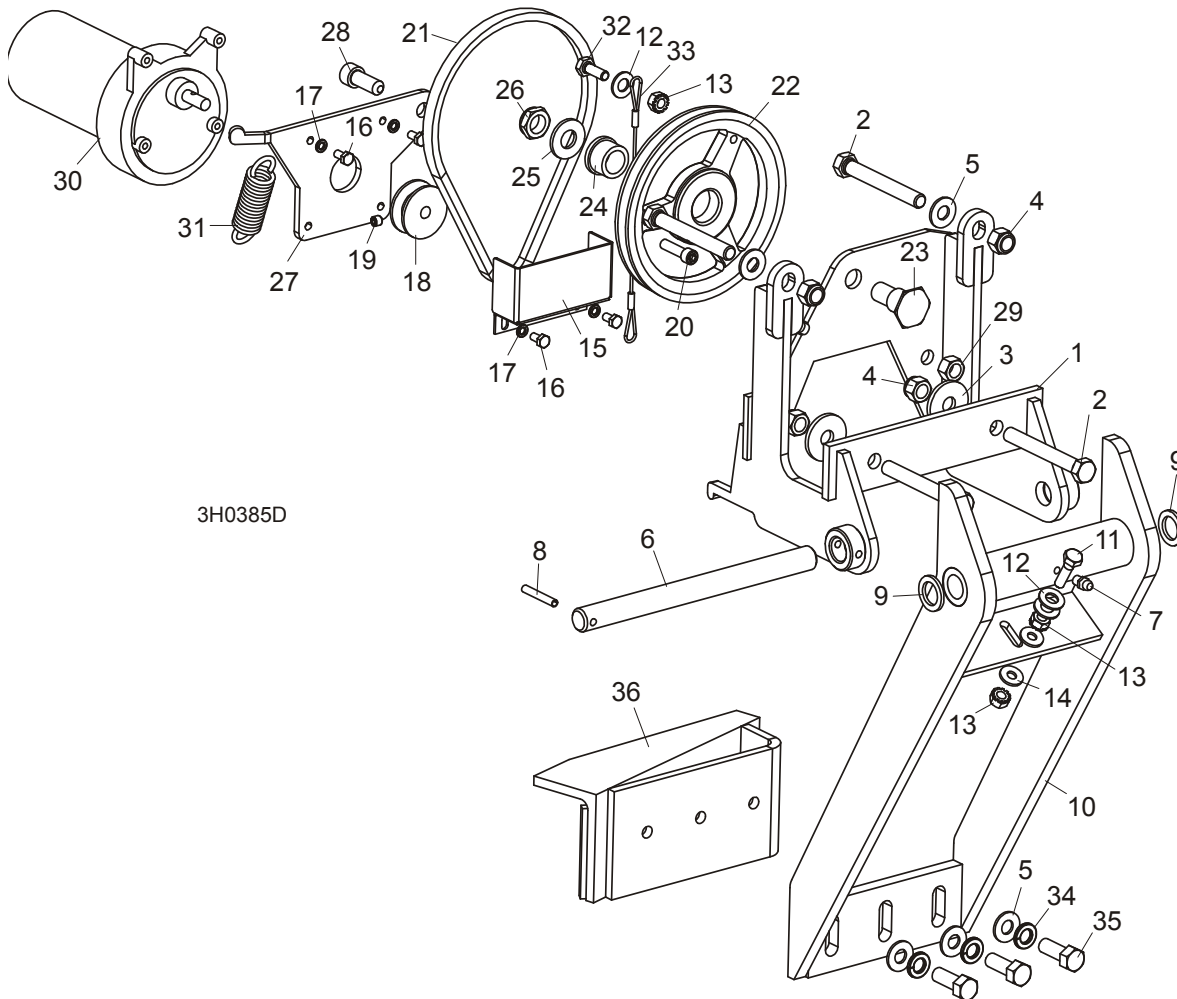

REF	DESCRIPTION (◆ Indicates Parts Available In Assemblies Only)	PART #	QTY.
	<b>RETURN ASSEMBLY, BOARD</b>	015209	1
1	Mount Weldment, Board Return	015215	1
2	Bolt, 3/8-16 x 3" Full Thread Hex Head	F05007-1	4
3	Washer, 1/8" x 1 1/4"	015336	2
4	Nut, 3/8-16 Hex Nylon Lock	F05010-10	4
5	Washer, 3/8" Flat	F05011-3	5
6	Rod Kit, Board Return Replacement Pivot	016272	1
7	Fitting, 1/4-28 Grease	P05060	1
8	Pin, 3/16 x 1 1/4" Roll	F05012-16	1
9	Washer, 5/8" x 15/16" x .094 Nylon	F05011-19	2
10	Arm Weldment, Board Return	015210	1
11	Screw, 1/4-20 x 3/4" Full Thread Hex Head	F05005-1	1

## 4

**Saw Head***Board Return Assembly*

12	Washer, 5/16" SAE Flat	F05011-17	3	
13	Nut, 1/4-20 Self-Locking	F05010-9	3	
14	Washer, 1/4" SAE Flat	F05011-11	2	
15	Guard, Board Return Belt	015007	1	
16	Screw, #10-32 x 1/2" Hex Head Machine	F05004-60	4	
17	Washer, #10 Split Lock	F05011-20	4	
18	Pulley, 1.42" x .32"	015074	1	
19	Screw, 1/4-28 x 1/4" Socket Head Cup Point Set	F05005-105	1	
20	Bolt, 1/4-20 x 1" Socket Head	F05005-89	1	
21	Belt, 3L190	015477	1	
22	Pulley, OK50 x 1/2" Modified	015224	1	
23	Bolt, Idler Pulley Pivot	015221	1	
24	Bushing, 5/8" x 7/8" x 1/2" Bronze	P05135	1	
25	Washer, 1/2" SAE Flat	F05011-2	1	
26	Nut, 1/2-20 Nylon Lock Jam	F05010-79	1	
27	Plate, Motor Pivot	015220	1	
28	Bolt, 3/8-16 x 1" Socket Head	F05007-52	1	
29	Nut, 3/8-16 Self-Locking	F05010-25	1	
30	Motor, 53:1 ASA Gear	P09698-1	1	
	Housing, Klauber Motor End	P12756	1	
	Gear Kit, Klauber Motor Replacement	P12569	1	
	Brush Kit, Gear Motor Replacement	P12800	1	
	Shaft Kit, Klauber Gear Motor Replacement	009695	1	
31	Spring, 3/4" x 2 7/8" x 12 Gauge	015479	1	
32	Bolt, 1/4-20 x 1" Hex Head Grade 5	F05005-101	1	
33	Cable, Board Return	016090	1	
34	Washer, 3/8" Split	F05011-4	3	
35	Bolt, 3/8-16 x 1" Hex Head	F05007-7	3	
36	Angle, Board Return	015652	1	



### 4.6 Water Lube Assembly

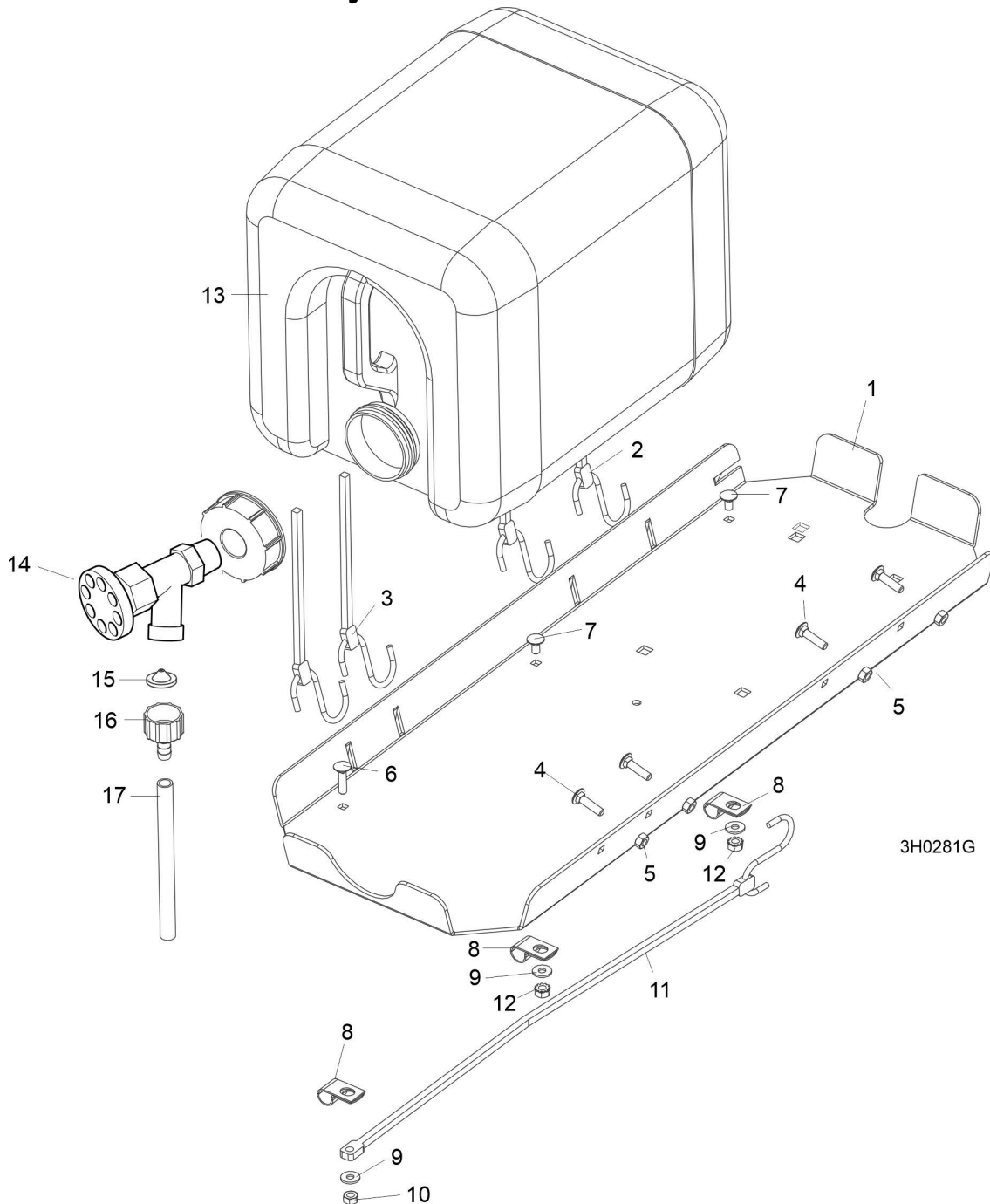

REF	DESCRIPTION (◆ Indicates Parts Available In Assemblies Only)	PART #	QTY.	
	<b>TRAY ASSEMBLY, FUEL TANK/WATER BOTTLE</b>	A11685	1	
1	Tray, Fuel Tank/Water Bottle	S11684	1	◆
2	Strap, 24" Rubber (For Fuel Tank - See Engine Manual)	P11258	2	
3	Strap, 20" Rubber	P11668	2	

## 4

**Saw Head***Water Lube Assembly*

4	Bolt, 1/4-20 X 1" Carriage Head	F05005-34	4	
5	Nut, 1/4-20 Hex Lock	F05010-21	4	
6	<b>BOLT, 1/4-20 X 1" CARRIAGE HEAD</b>	F05005-34	1	
7	<b>BOLT, 1/4-20 X 1/2" CARRIAGE HEAD</b>	F05005-33	2	
8	<b>CLAMP, 1/2" EMT HOSE</b>	P07584	3	
9	<b>WASHER, 1/4" SAE FLAT</b>	F05011-11	3	
10	<b>NUT, 1/4-20 HEX LOCK</b>	F05010-21	1	
11	<b>STRAP, 15" RUBBER</b>	P07461	1	
12	<b>NUT, 1/4-20 SELF-LOCKING</b>	F05010-9	2	
13	<b>BOTTLE ASSY, WATER LUBE W/CAP</b>	014642 <sup>1</sup>	1	
	FITTING, 3/4FPT X 3/4MPT	014636 <sup>2</sup>	1	
14	<b>VALVE, 3/4 NPT ELBOW 3/4 MALE GHT OUTLET</b>	133320 <sup>3</sup>	1	
	FITTING, WATER LUBE SHUTOFF VALVE	014100	1	
15	<b>FILTER, WATER LUBE</b>	016086 <sup>4</sup>	1	
16	<b>FITTING, 5/8" NPT TO 3/8" HOSE BARB</b>	014113	1	
17	<b>TUBING, WATER LUBE 3/8" I.D.</b>	R01885	7 ft.	

<sup>1</sup> Use Water Bottle Assembly w/Cap 014642 to service all bottle/cap combinations previously supplied. Bottle 014367, 61mm Cap 014773 and 70mm Cap 036744 no longer available separately.

<sup>2</sup> Deleted after 9/19/2022 per ECN 38718.

<sup>3</sup> Replaced 014100 after 9/19/2022 per ECN 38718.

<sup>4</sup> Filter recommended for LT50 models to prevent debris from entering water lube solenoid valve.

## 4.7 Saw Head Decals

LT50HD

Rev. A2.00 (1/08) - A5.02

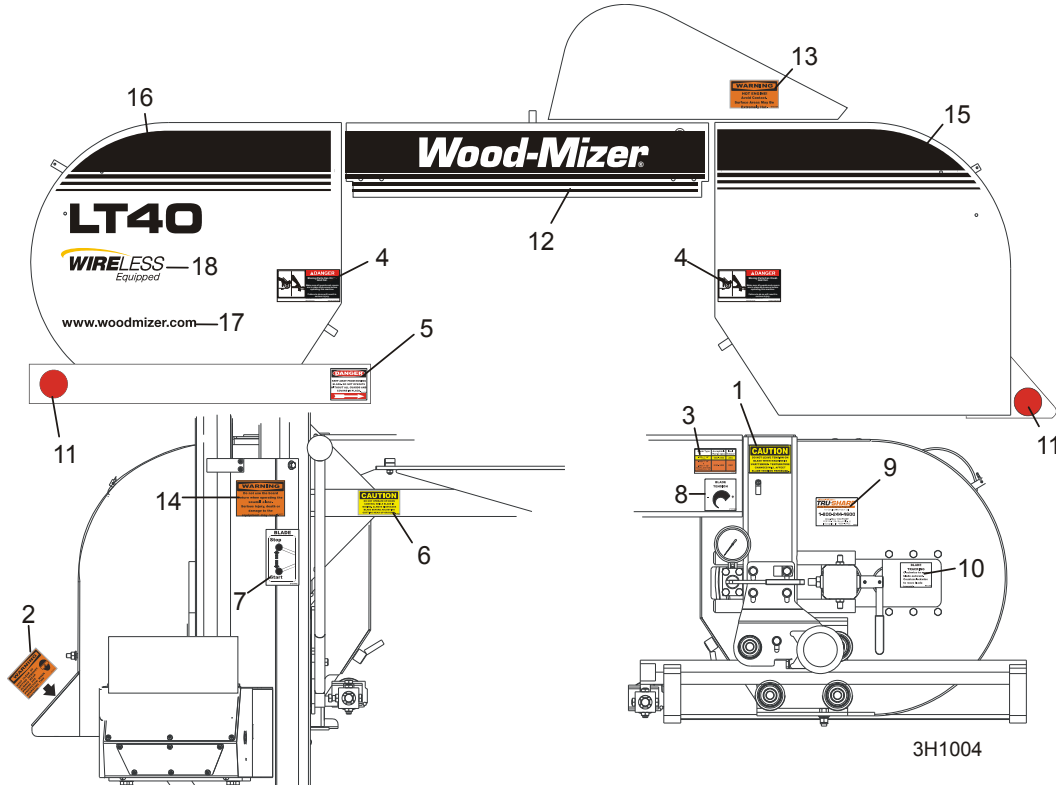

REF	DESCRIPTION (◆ Indicates Parts Available In Assemblies Only)	PART #	QTY.
1	DECAL, BLADE TENSION CAUTION	P10147	1
2	DECAL, SAWDUST CHUTE WARNING	P11754	1
3	DECAL, BLADE TENSION RANGES	P12373	1
4	DECAL, BLADE COVERS DANGER	033254	2
5	DECAL, BLADE DANGER ARROW RIGHT	S11752	1
6	DECAL, UP/DOWN CAUTION	S11762	1
7	DECAL, BLADE START/STOP	P11779	1
8	DECAL, BLADE TENSION INFO	P11790	1
9	DECAL, TRU-SHARP INFO	P12879	1
10	DECAL, BLADE ALIGNMENT INFO	P11789	1
11	DECAL, RED REFLECTIVE 2" ROUND	P07452	2
12	DECAL, MIDDLE COVER	003244	1
13	DECAL, HOT ENGINE WARNING	014419	1
14	DECAL, BOARD RETURN OPERATOR WARNING	016072	1
15	DECAL, BLADE HOUSING COVER (DRIVE SIDE)	003243	1
16	DECAL, BLADE HOUSING COVER (IDLE SIDE LT50)	003247	1
17	DECAL, WOOD-MIZER WEBSITE	003235	1
18	DECAL, WIRELESS EQUIPPED LOGO	057782	1

# 4 Saw Head

## Blade Housing Covers

### 4.8 Blade Housing Covers

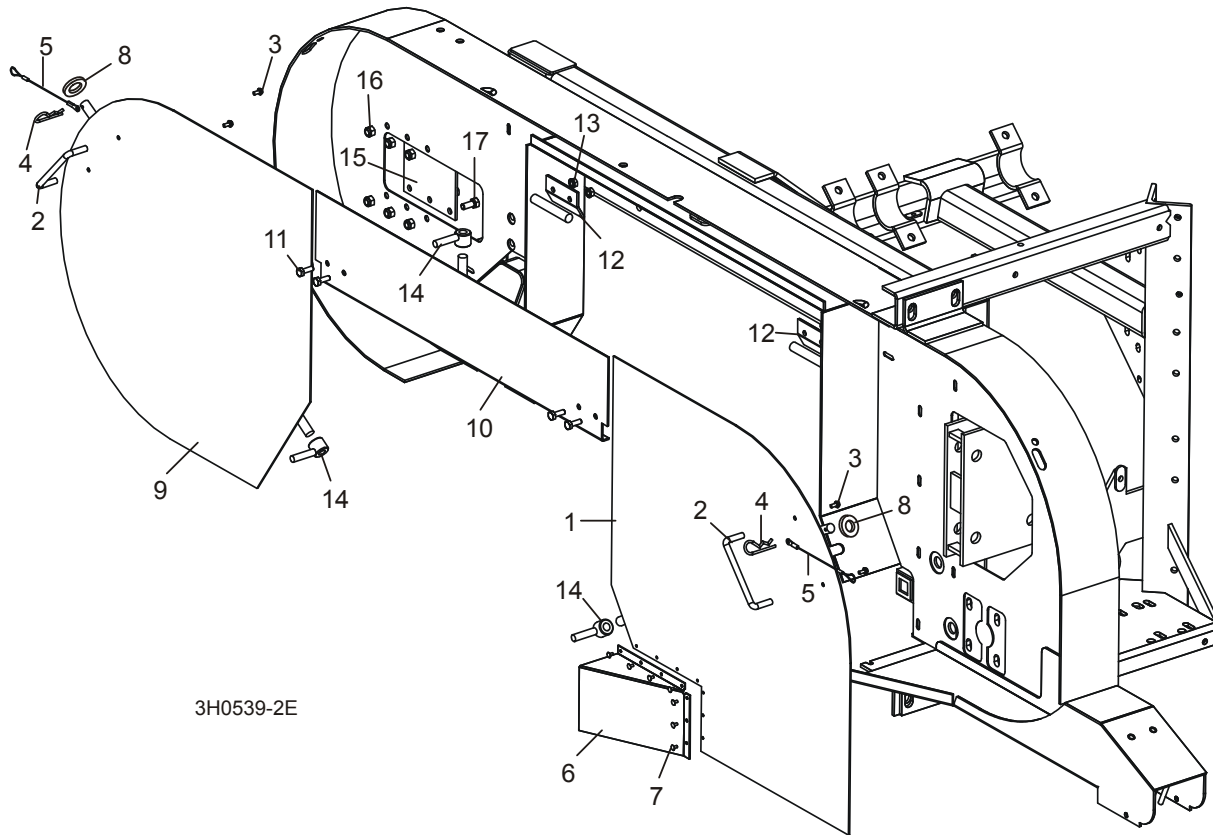

REF	DESCRIPTION (◆ Indicates Parts Available In Assemblies Only)	PART #	QTY.	
	<b>COVER ASSEMBLY, DRIVE SIDE BLADE HOUSING WITH HANDLE</b>	015937	1	
1	Cover, Drive Side Blade Housing (Includes Cover Decal - <a href="#">See Section 4.9</a> )	015911	1	◆
2	Handle, Blade Housing Cover	P08065	1	
3	Screw, #8-32 X 3/8" Self-Tap	F05015-8	2	
	Pin Assembly, Cover Retainer	A12812	1	
4	Pin, Safety Retainer	P05059	1	
5	Cable, 3/64" x 6" Lanyard	016030	1	
6	Funnel, Sawdust Exit	015734	1	
7	Rivet, 1/8" x 1/8" Aluminum Pop	F04203-8	7	
8	Washer, 1/2" ID x 1 1/8" OD x .093" Rubber	F05011-87	1	
	<b>COVER, IDLE SIDE BLADE HOUSING WITH HANDLE</b>	A09419	1	
9	Cover, Idle Side Blade Housing (Includes Cover Decal - <a href="#">See Section 4.9</a> )	W09351	1	◆
2	Handle, Blade Housing Cover	P08065	1	
3	Screw, #8-32 X 3/8" Self-Tap	F05015-8	2	
	Pin Assembly, Cover Retainer	A12812	1	
4	Pin, Safety Retainer	P05059	1	

5	Cable, 3/64" x 6" Lanyard	016030	1	
8	Washer, 1/2" ID x 1 1/8" OD x .093" Rubber	F05011-87	1	
10	<b>COVER, MIDDLE BLADE HOUSING</b>	W07409	1	
11	<b>BOLT, 1/4-20 X 3/4" HEX HEAD</b>	F05005-1	18	
12	<b>HINGE, MIDDLE BLADE HOUSING COVER</b>	S07522	2	
13	<b>NUT, 1/4-20 SELF-LOCKING HEX</b>	F05010-9	4	
14	<b>NUT, COVER TURN</b>	021145	3	
15	<b>PLATE, IDLE BLADE WHEEL GUARD</b>	S04433	1	
16	<b>NUT, 5/16-18 HEX NYLON LOCK</b>	F05010-58	6	
17	<b>BOLT, 5/16-18 X 3/4" HEX HEAD GRADE 2</b>	F05006-5	6	

### 4.9 Drive Belt Covers

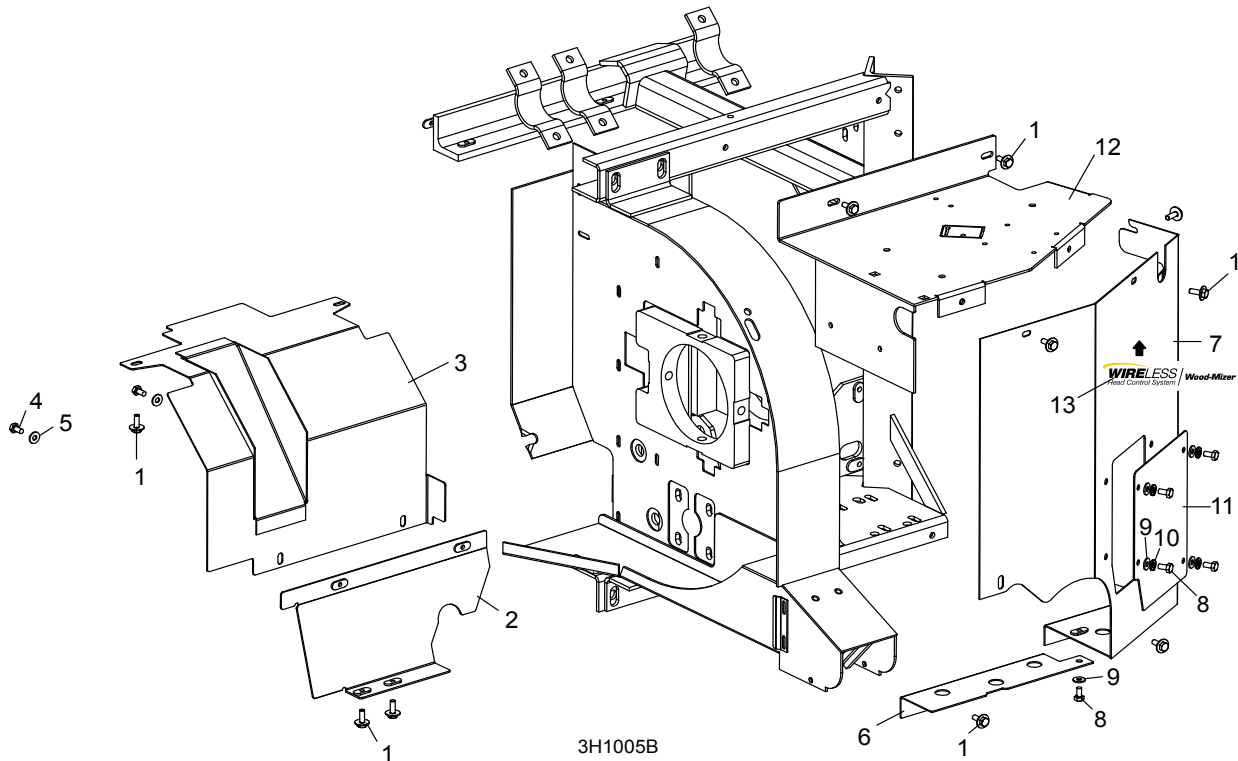

REF	DESCRIPTION (◆ Indicates Parts Available In Assemblies Only)	PART #	QTY.	
1	<b>BOLT, 1/4-20 X 3/4" HEX HEAD WITH CONICAL WASHER</b>	F05005-134	11	
2	<b>GUARD WELDMENT, SUPER/REMOTE LOWER DRIVE BELT</b>	006026 <sup>1</sup>	1	
3	<b>MOUNT WELDMENT, LOWER DRIVE BELT</b>	006025	1	
4	<b>BOLT, 1/4-20 X 1/2" HEX HEAD</b>	F05005-15	2	
5	<b>WASHER, 1/4" SAE FLAT</b>	F05011-11	2	
	<b>GUARD ASSEMBLY, DRIVE PULLEY SIDE</b>	015155 <sup>2</sup>	1	
6	Guard Weldment, Lower Up/Down	015654	1	
7	Guard Weldment, C-Frame Enclosure '97	015655 <sup>2</sup>	1	◆
8	Bolt, 1/4-20 x 1/2" Hex Head	F05005-15	5	
9	Washer, 1/4" SAE Flat	F05011-11	5	
10	Washer, 1/4" Split Lock	F05011-14	4	
11	Plate, Belt Cover Enclosure	006870	1	
12	<b>GUARD, DRIVE PULLEY TOP</b>	W11750	1	
13	<b>DECAL, WIRELESS HEAD CONTROL SYSTEM LOGO</b>	057781	1	

<sup>1</sup> For sawmills equipped with standard manual clutch handle only. See Autoclutch Option manual for alternate guards.

<sup>2</sup> Guard Assembly 015155 includes Guard Weldment 015655 modified Rev. A5.01. Cutout added to accommodate Simple Set encoder sensor. Plate 006870 added to cover cutout on sawmills without Simple Set.

### 4.10 Sawdust Chute

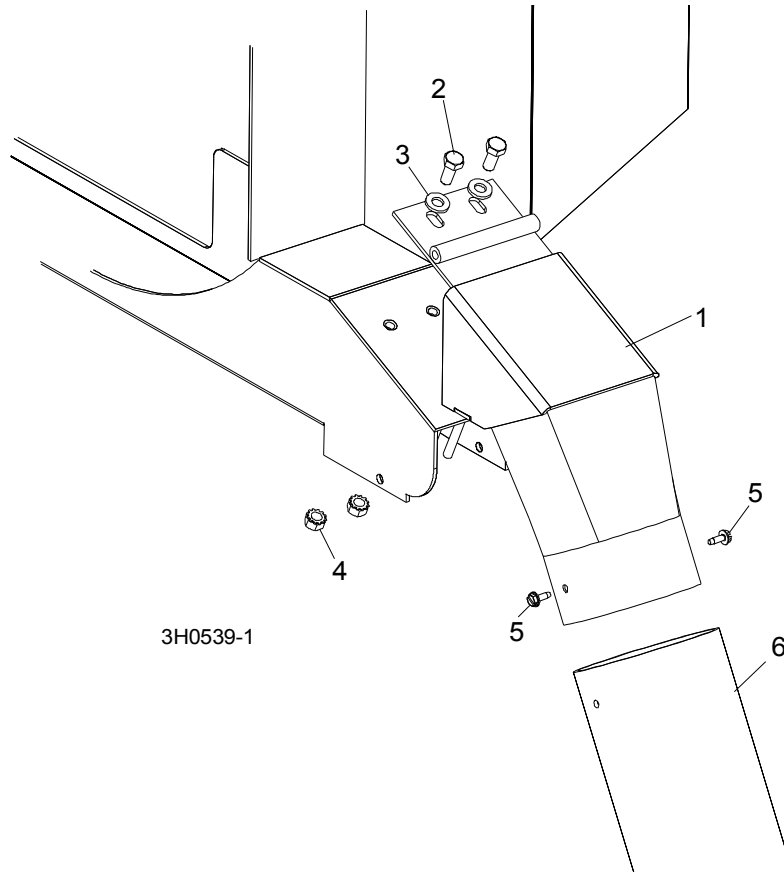

REF	DESCRIPTION (◆ Indicates Parts Available In Assemblies Only)	PART #	QTY.
1	CHUTE WELDMENT, SAWDUST	015466	1
2	BOLT, 5/16-18 X 3/4" HEX HEAD GRADE 2	F05006-5	2
3	WASHER, 5/16" SAE FLAT	F05011-17	2
4	NUT, 5/16-18 SELF-LOCKING HEX	F05010-20	2
5	BOLT, #10-24 X 1/2" SELF-TAPPING	F05015-7	2
6	TUBING, RUBBER SAWDUST	016727	1
	STRAP, 20" RUBBER W/HOOK	P11668	1
	BOLT, 1/4-20 X 1 1/4" HEX HEAD FULL THREAD	F05005-3	1
	WASHER, 1/4" SAE FLAT	F05011-11	1
	NUT, 1/4-20 LOCK	F05010-21	1

**4** Saw Head  
 Debarker Wire Box/Hole Plugs

**4.11 Debarker Wire Box/Hole Plugs**

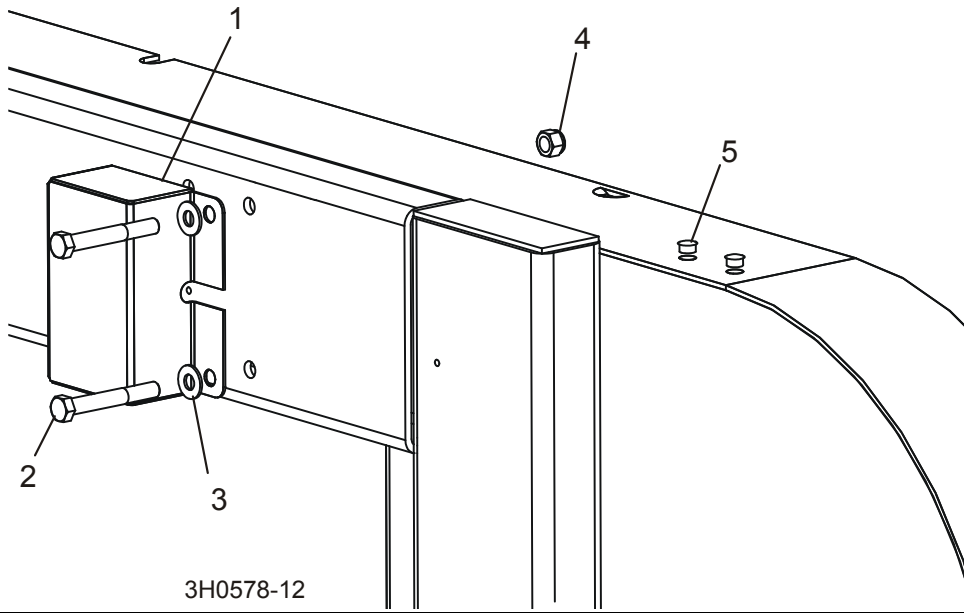

REF	DESCRIPTION (◆ Indicates Parts Available In Assemblies Only)	PART #	QTY.
1	BOX, DEBARKER WIRE STORAGE	023616	1
2	BOLT, 3/8-16 X 2 3/4" HEX HEAD	F05007-29	2
3	WASHER, 3/8" SAE FLAT	F05011-3	2
4	NUT, 3/8-16 HEX NYLON LOCK	F05010-10	2
5	PLUG, 13/32" PLASTIC HOLE	014537	2



SECTION 5 CONTROL & BATTERY BOXES

5.1 Control Assembly

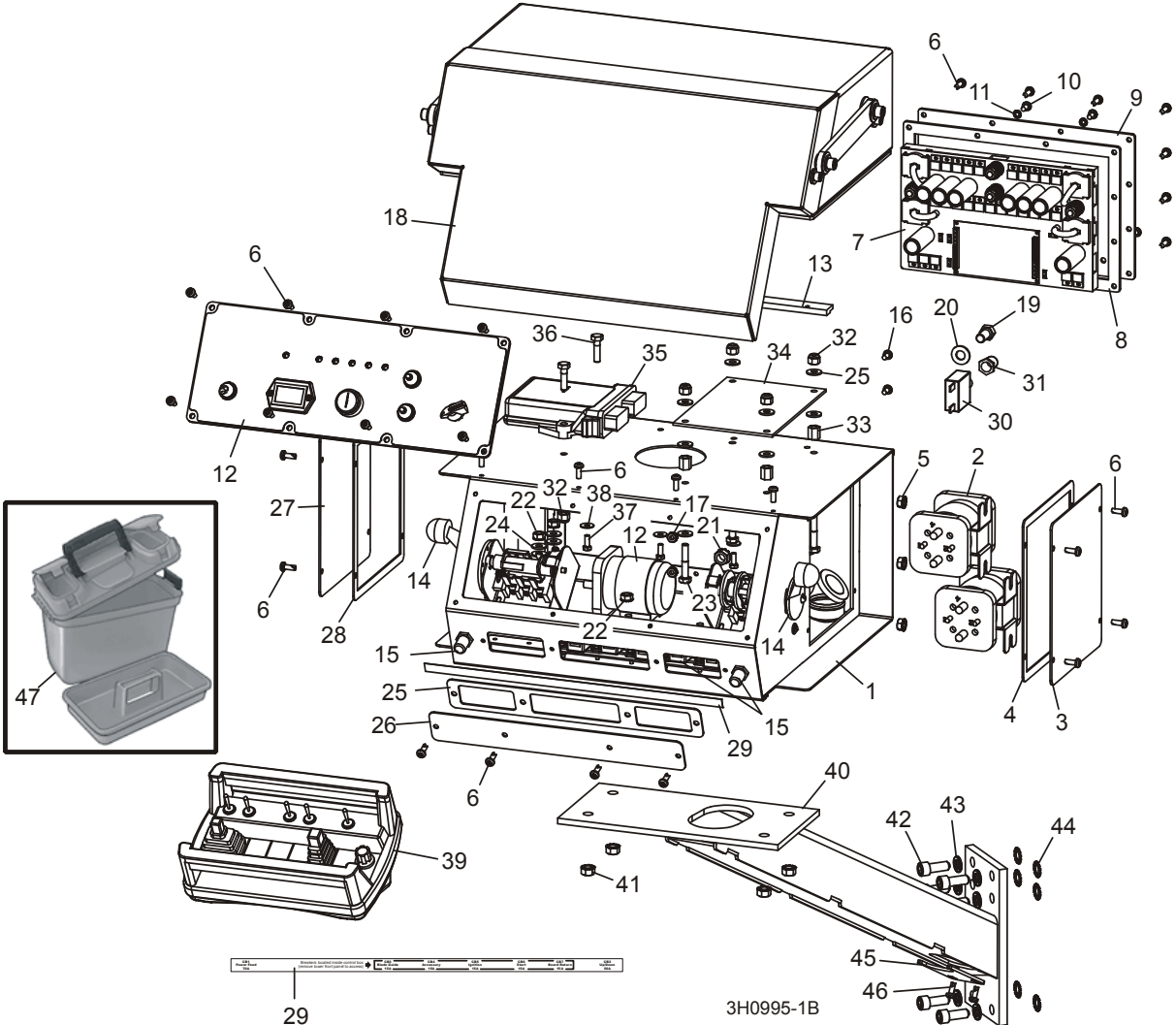

REF	DESCRIPTION (◆ Indicates Parts Available In Assemblies Only)	PART #	QTY.	
	COVER, SAWMILL CONTROL CONSOLE W/ACCUSET	036352	1	
	CONTROL BOX ASSEMBLY, G38 WIRELESS	053185	1	
	CONTROL BOX ASSEMBLY, E25 SOFTSTART WIRELESS	053188	1	
	CONTROL BOX ASSEMBLY, D47 WIRELESS	053276	1	
	CONTROL BOX ASSEMBLY, D51 SOFTSTART WIRELESS	053186	1	
1	Box Weldment, Wireless Sawmill Control	057815	1	◆
	Panel Assembly, Solenoid Up/Down	015425	1	
2	Solenoid Kit, 200A 12V DPST	016370	2	
	Solenoid, 200A 12 DPST	015417	1	◆

# 5 Control & Battery Boxes

## Control Assembly

	Diode Assembly, Solenoid Coil Chassis GND	015426	1	
3	Panel Weldment, Side	015307	1	
4	Gasket, Side Panel Control	015274	1	
5	Nut, 1/4-20 Self Locking	F05010-9	3	
6	Screw, #10-24 x 1/2" Pan Head	F05015-17	36	
	Panel Assembly, Power Feed Control	051887 <sup>1</sup>	1	◆
7	Control Module, Power Feed	051667	1	◆
8	Gasket, Rear Panel	047938	1	
9	Plate, Power Feed Module	047698	1	
10	Screw, #10-24 X 3/8" Phillips Pan Head	F05004-3	6	
11	Washer, #10 Split Lock	F05011-20	6	
12	Front Control Panel & Wiring Harnesses ( <a href="#">Section 5.6</a> )			
13	Bracket, Box Hold Down	015296	1	
14	Drum Switches ( <a href="#">Section 5.3</a> )			
15	Circuit Breakers ( <a href="#">Section 5.3</a> )			
16	Screw, #10-24 x 3/8" Phillips Pan Head	F05004-3	2	
17	Nut, #10-24 Self Locking	F05010-14	2	
18	Cover Assembly ( <a href="#">Section 5.3</a> )			
19	Bolt, 3/8-16 x 3/4" Hex Head	F05007-27	1	
20	Washer, 3/8" SAE Flat	F05011-3	1	
21	Nut, 3/8" Lock Nut	F05010-19	1	
22	Nut, 1/4-20 Self Locking	F05010-9	4	
23	Bolt, 1/4-20 x 1 1/2" Hex Head Full Thread	F05005-31	4	
24	Washer, 1/4 SAE Flat	F05011-11	16	
25	Gasket, Front Access Panel	015266	1	
26	Panel, Control Box Front Access	015376	1	
27	Panel Weldment, Side	006473	1	
28	Gasket, Side Panel Control	015274	1	
29	Decal, Circuit Breaker ID ('98 Super)	024362	1	
30	Breaker, 30A Manual Reset Panel Mount	024246	1	
31	Boot, Circuit Breaker	021253	1	
32	Nut, 1/4-20 Nylon Lock	F05010-69	6	
33	Standoff, 1/4 x 20 Female Threaded	053149	4	
34	PCB Assembly, Wireless Sawmill Interface	053148	1	
	Relay, 12A 12VDC DPDT	053144	7	
	Fuse, 10A ATO Blade Red	024150-10	1	
35	Receiver Kit, Wireless R160 w/Instructions	053218	1	
36	Screw, 1/4-20 x 1 Hex Head Cap	F05005-38	2	
37	Screw, 10-24 x 1/2 Hex Head	F05004-27	4	
38	Washer, #10 SAE Flat	F05011-18	4	
39	Transmitter Kit, Wireless T300 w/Instructions	053217	1	
	Switch Kit, Omnex T300 Replacement E-Stop	053638	1	
	Switch Kit, Omnex T300 DT Momentary Toggle	053639	1	

	Switch Kit, Omnex T300 ST Maintained Toggle	053640	1	
	Switch Kit, Omnex T300 Variable Feed Potentiometer	053641	1	
	Switch Kit, Omnex T300 Up/Down Paddle	053642	1	
	Switch Kit, Omnex T300 Fwd/Rev/BG In-Out Joystick	053643	1	
	Harness, Wireless T300 Transmitter Orange Tear Away	053159	1	
<b>40</b>	<b>MOUNT WELDMENT, STANDARD CONTROL BOX</b>	015236	1	
<b>41</b>	<b>NUT, 5/16-18 SELF-LOCKING HEX</b>	F05010-20	4	
<b>42</b>	<b>BOLT, 3/8-16 X 1" SOCKET HEAD</b>	F05007-52	6	
<b>43</b>	<b>WASHER, 3/8" SPLIT LOCK</b>	F05011-4	6	
<b>44</b>	<b>WASHER, 3/8" EXTERIOR STAR LOCK</b>	F05011-36	6	
<b>45</b>	<b>PLATE, PEDESTAL COVER</b>	036381	1	
<b>46</b>	<b>SCREW, #10-24 X 1/2" PAN HEAD</b>	F05015-17	2	
<b>47</b>	<b>BOX, PLASTIC WIRELESS CONTROL STORAGE</b>	006472	1	

<sup>1</sup> Power Feed Module 051887 discontinued 12/10. If sawmill not equipped with Accuset 2 option, use kit 069460 to retrofit power feed with dual-axis motor control module. If sawmill equipped with Accuset 2 option, use kit 069461 to retrofit for dual-axis control of power feed motor. If Accuset 2 is older than Rev. B.00 with original part 052974 single-axis control module (No MOT2A or MOT2B terminal studs), a new dual-axis module 057821LS-FR is required in addition to kit 069461.

## 5.2 Cover Assembly

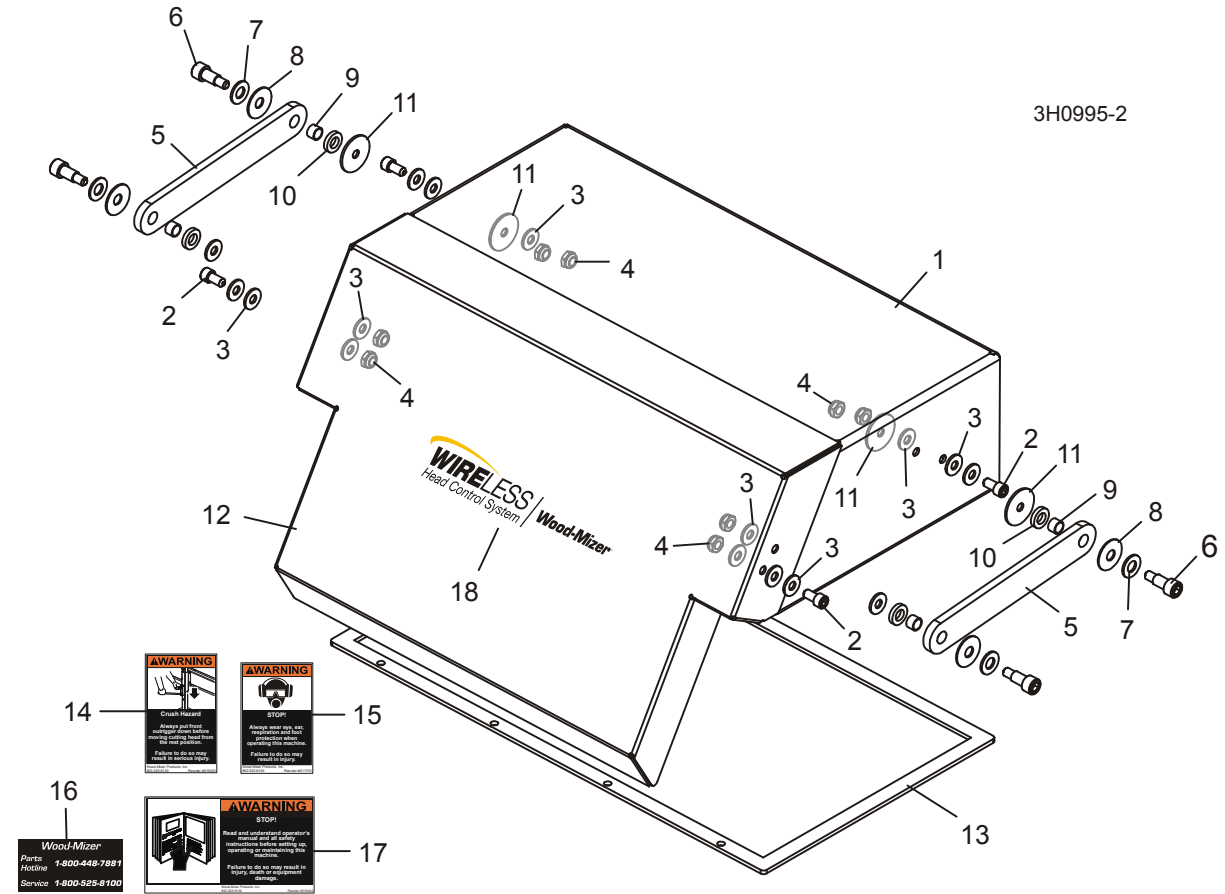

REF	DESCRIPTION (◆ Indicates Parts Available In Assemblies Only)	PART #	QTY.
	<b>COVER ASSEMBLY, WIRELESS SAWMILL</b>	053184	1
1	Box Weldment, Wireless	057819	1
2	Screw, 1/4-20 x 1/2" Socket Head	F05005-148	2
3	Washer, 1/4 SAE Flat	F05011-11	16
4	Nut, 1/4-20 Hex Half Nylon Lock	F05010-156	8
5	Link, AccuSet Cover	016704	2
6	Bolt, 5/16" x 1/2" Shoulder 1/4-20 Thread	F05006-69	4
7	Washer, 5/16" SAE Flat	F05011-17	4
8	Washer, 5/16" Belleville	F05011-93	4
9	Bushing, 5/16" ID x 3/8" OD x 1/4" Long Bronze	016655	4
10	Washer, 5/16" Flat Nylon	F05011-92	4
11	Washer, 1/4" Fender	F05011-12	4
12	Cover, AccuSet Pointed	016703	1
13	Gasket, Setworks Control Assembly	015980	1
14	Decal, Front OUtrigger Warning	015400	1

---

<b>15</b>	Decal, Eye/Ear Protection Warning	S11753	1	
<b>16</b>	Decal, 800 Number	S12117	1	
<b>17</b>	Decal, Read Manual Warning	016402	1	
<b>18</b>	<b>DECAL, WIRELESS HEAD CONTROL SYSTEM LOGO</b>	057781	1	

### 5.3 Drum Switches

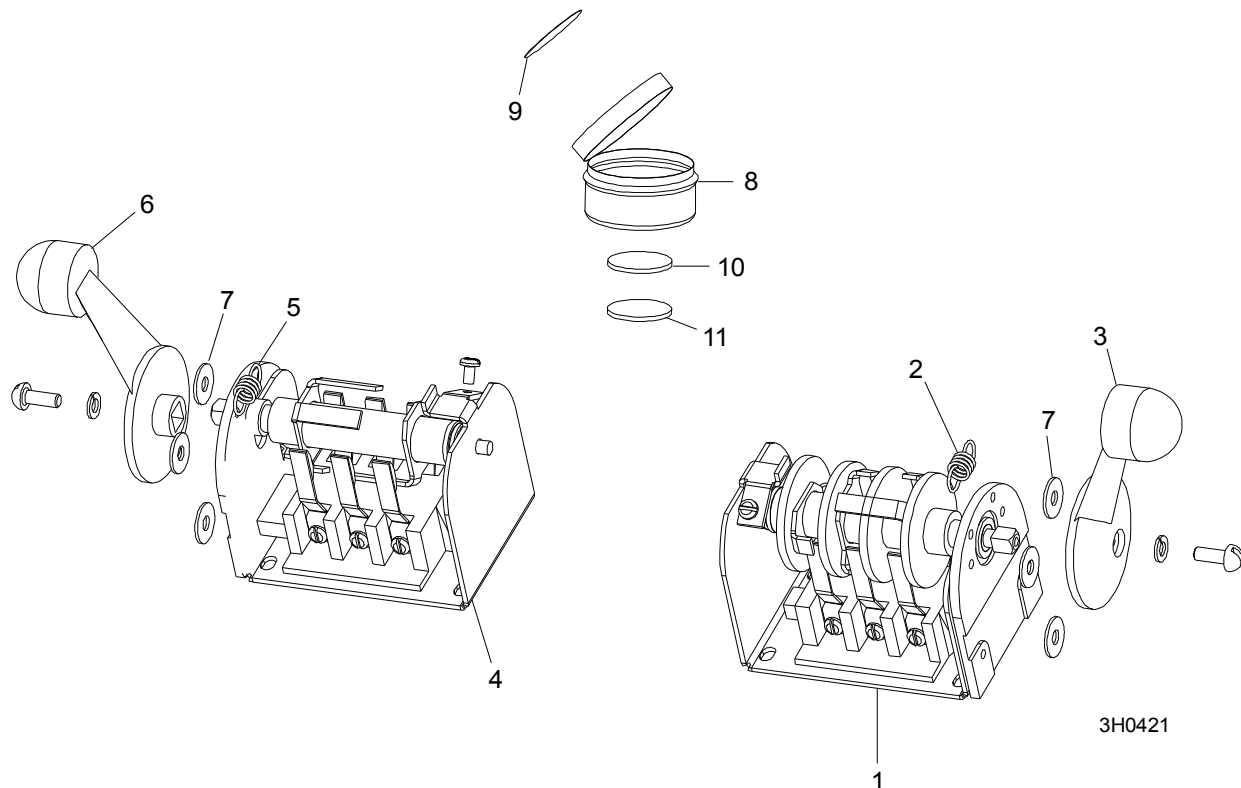

REF	DESCRIPTION (◆ Indicates Parts Available In Assemblies Only)	PART #	QTY.	
	<b>SWITCH ASSEMBLY, UP/DOWN DRUM</b>	E20440	1	
1	Switch, S12 Bulk Drum	E20440-B	1	◆
2	Spring, Drum Switch	P12570	1	
3	Handle, Drum Switch Replacement	P12500	1	
	<b>SWITCH ASSEMBLY, POWER FEED DRUM</b>	E20439	1	
4	Switch, S11 Bulk Drum	E20439-B	1	◆
5	Spring, Drum Switch	P12570	1	
6	Handle, Drum Switch Replacement	P12500	1	
7	<b>WASHER, #8 SAE FLAT</b>	F05011-41	6	
	<b>CUP ASSEMBLY, DRUM SWITCH GREASE</b>	A20463	1	
8	Cup, Plastic Container	P20464	1	◆
9	Decal, Grease Cup Label	P20467	1	
10	Pad, Velcro Loop	P20466	1	◆
11	Pad, Velcro Hook	P20465	1	◆
	Grease, High Temp Drum Switch	P20468	.025 Lb	◆

## 5.4 Circuit Breakers

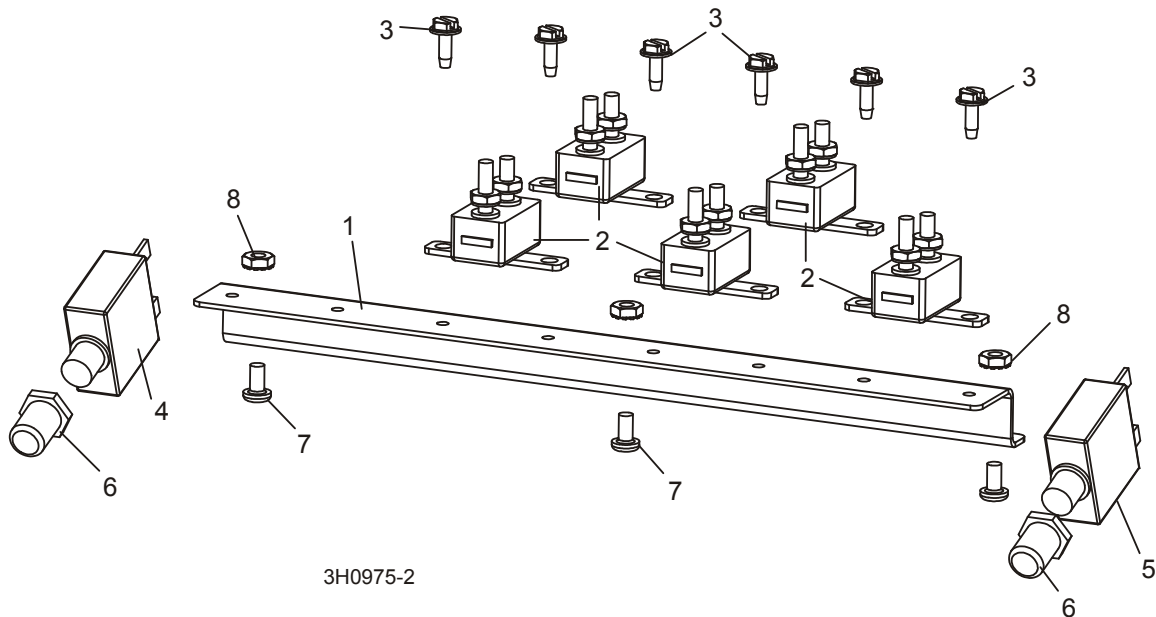

REF	DESCRIPTION (◆ Indicates Parts Available In Assemblies Only)	PART #	QTY.
	<b>BREAKER ASSEMBLY, SAWMILL CONTROL CIRCUIT (DC)</b>	015621	1
1	Rail, Circuit Breaker	052826	1
2	Breaker, 15 Amp Manual Reset	E20430	5
3	Screw, #10-24 x 1/2" Self-Tapping	F05015-7	6
4	<b>BREAKER, 70 AMP MANUAL RESET PANEL MOUNT</b>	015527	1
5	<b>BREAKER, 50 AMP MANUAL RESET PANEL MOUNT</b>	021256	1
6	<b>BOOT, CIRCUIT BREAKER</b>	021253	2
7	<b>SCREW, #10-24 X 3/8" PHILLIPS PAN HEAD</b>	F05004-3	3
8	<b>NUT, #10-24 SELF LOCKING</b>	F05010-14	3

### 5.5 Front Panel Assembly & Harnesses

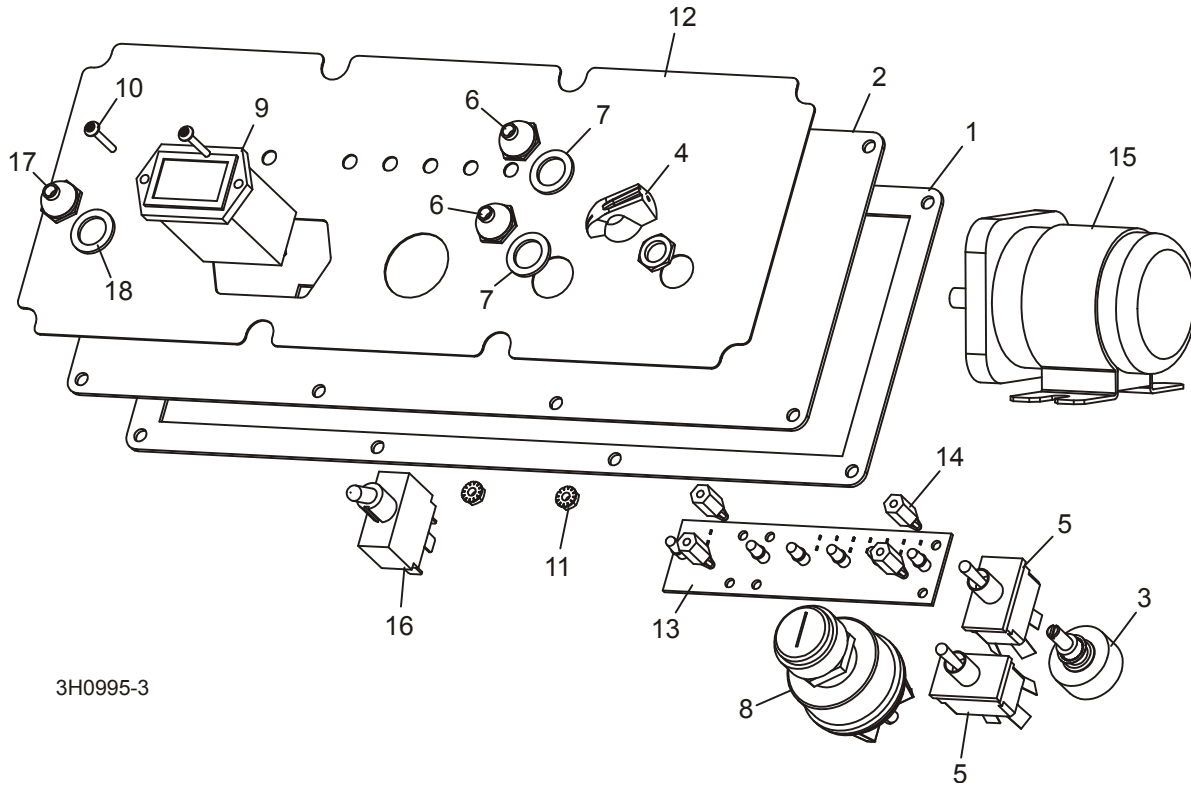

3H0995-3

REF	DESCRIPTION (◆ Indicates Parts Available In Assemblies Only)	PART #	QTY.
	<b>PANEL ASSEMBLY, CONTROL FRONT (E25)</b>	051875	1
	<b>PANEL ASSEMBLY, CONTROL FRONT (G38/D47/D51)</b>	051876	1
1	Gasket, Front Panel	015270	1
2	Panel Weldment, Control	015302	1
3	Switch Assembly, Feed Rate	024450-1	1
4	Knob, Feed Rate With Set Screw	P06257	1
5	Switch, Toggle	024200	2
6	Boot, Toggle Switch Rubber	P02575	2
7	Washer, 12 x 3/4 x 1/16 Nylon	P05251-1	2
8	Switch, Key	P04350	1
9	Meter, Hour	015401	1
10	Screw, 6-42 x 3/4" Socket Button Head Cap Stainless Steel	F05004-93	2
11	Nut, 6-32 Self Locking	F05010-59	2
12	Decal, Control Panel (E25)	015271	1
	Decal, Control Panel (G38/D47/D51)	015269	1
13	Board, LED Circuit (E25)	015416	1
	Board, LED Circuit (G38/D47/D51)	015409	1
14	Spacer, 1/2"-#6 Threaded	023147	4



<b>15</b>	Solenoid Kit, 200A 12V SPST Cont. Duty	016371	1	
	Solenoid, 200A 12V SPST Cont. Duty	015470	1	◆
	Diode Assembly, Solenoid Coil Chassis Gnd	015426	1	
	Fuse Assembly, 2004 ATO w/Holder	051871	1	
	Fuse, 4A ATO Blade Pink	024150-4	1	
<b>16</b>	<b>SWITCH, BLADE START/STOP</b>	051346	1	
<b>17</b>	<b>BOOT, TOGGLE SWITCH RUBBER</b>	P02575	1	
<b>18</b>	<b>WASHER, 12 X 3/4 X 1/16 NYLON</b>	P05251-1	1	
	<b>HARNESS ASSEMBLY, UPPER WIRING (E25)</b>	051964	1	
	<b>HARNESS ASSEMBLY, UPPER WIRING (G38)</b>	052875	1	
	<b>HARNESS ASSEMBLY, UPPER WIRING (D47)</b>	053277	1	
	<b>HARNESS ASSEMBLY, UPPER WIRING (D51)</b>	052227	1	
	Conduit, 1 1/4" x 58" Flex	050399	1	
	Connector, 1 1/4" Straight Male Metal Conduit	024402	1	
	<b>HARNESS ASSEMBLY, LOWER WIRING</b>	051872	1	
	Conduit, 1/2" Expandable Black	R02374	41 in.	
	Conduit, 1/2" Expandable Black	R02374	42 in.	

## 5.6 Battery Box Assembly

LT50HD

Rev. A5.00 - A5.02

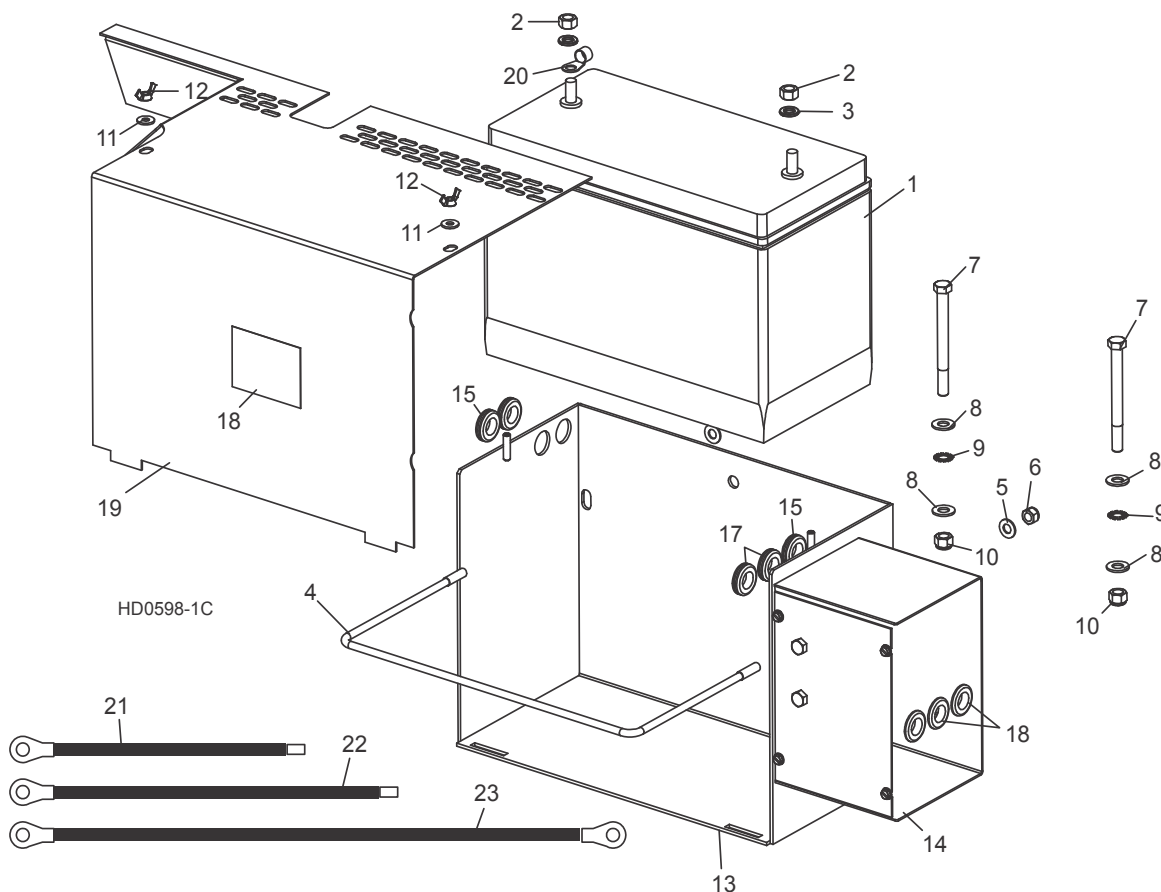

REF	DESCRIPTION (◆ Indicates Parts Available In Assemblies Only)	PART #	QTY.	
1	<b>BATTERY, 12 VOLT 8A31DTM AGM</b>	025841 <sup>1</sup>	1	◆
	<b>BOX ASSEMBLY, SUPER HYDRAULIC BATTERY</b>	015565 <sup>2</sup>	1	
2	Nut, 3/8-16 Hex	F05010-1	2	
3	Washer, 3/8" Split Lock	F05011-4	2	
4	Retainer Loop, Battery	015194	1	
5	Washer, 5/16" SAE Flat	F05011-17	2	
6	Nut, 5/16-18 Hex Nylon Lock	F05010-58	2	
7	Bolt, 3/8-16 X 4" Hex Head Grade 2	F05007-4	2	
8	Washer, 3/8" SAE Flat	F05011-3	2	
9	Washer, 3/8" External Star	F05011-36	2	
10	Nut, 3/8" Hex Nylon Lock	F05010-10	2	
11	Washer, 1/4" SAE Flat	F05011-11	2	

12	Nut, 1/4-20 Wing	F05010-13	2	
13	Box Weldment, Battery	015191	1	
14	Fuse Box Parts ( <a href="#">See Section 5.6</a> )			
15	Grommet, 5/8" Rubber Wire	P11764	3	
16	Terminal, 3/8 1-2 Ga Ring NI Loose	F05092-28	1	
17	Grommet, 3/4" ID 11 Gauge Thickness	074198	1	
18	Grommet, 3/4" ID 16 Gauge Thickness	074199	2	
	Hydraulic Positive Contact Parts ( <a href="#">See Section 10.4</a> )			
19	<b>LID WELDMENT, BATTERY BOX SUPER</b>	015771	1	
20	<b>DECAL, BATTERY BOX LID CAUTION</b>	014774	1	
21	<b>CABLE ASSEMBLY, 1 GA X 12" 150A FUSE TO BATTERY POSITIVE</b>	036308	1	
22	<b>CABLE ASSEMBLY, 1 GA X 16" 225A FUSE TO BATTERY POSITIVE</b>	036309	1	
23	<b>CABLE ASSEMBLY, 1 GA X 26" BATTERY NEGATIVE TO NEG. CONTACT</b>	036306	1	

<sup>1</sup> Replaces 12 Volt Battery (015475) supplied prior to . 12 Volt Battery (015475) changed to be equipped with one threaded stud (5/11).

<sup>2</sup> Battery terminals (P05085), washer (P12161), 1/4" exterior star washer (F05011-37) and 1/4-20 hex self-locking nut (F05010-9) replaced with ring terminals and fasteners for batteries with threaded studs (5/11).

## 5.7 Battery Box Assembly

LT50HD

Rev. A1.01 - A4.00

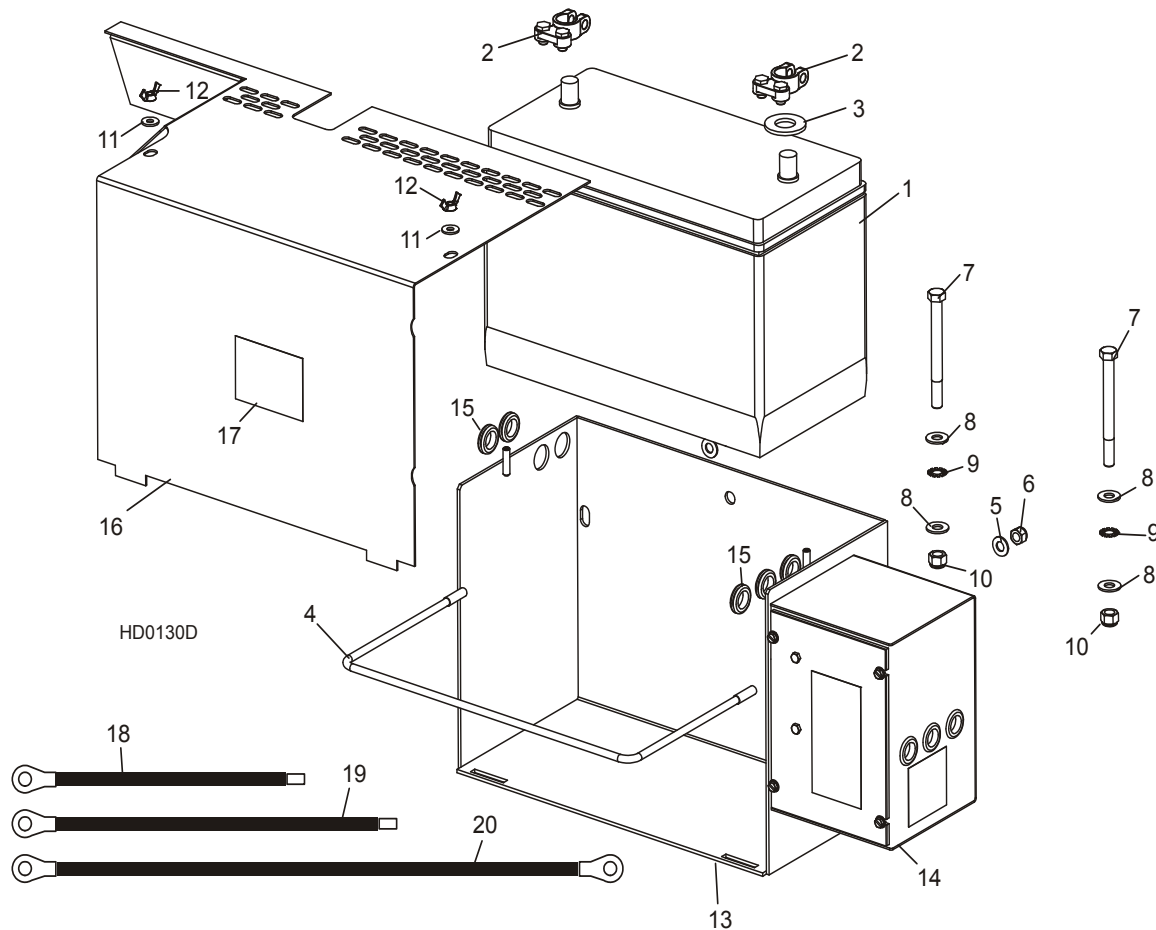

REF	DESCRIPTION (◆ Indicates Parts Available In Assemblies Only)	PART #	QTY.	
1	<b>BATTERY, 12 VOLT <sup>1</sup></b>	015475	1	◆
	<b>BOX ASSEMBLY, SUPER HYDRAULIC BATTERY</b>	015565 <sup>2</sup>	1	
2	Terminal, Battery	P05085	2	
3	Washer, Battery Terminal	P12161	1	
4	Retainer Loop, Battery	015194	1	
5	Washer, 5/16" SAE Flat	F05011-17	2	
6	Nut, 5/16-18 Hex Nylon Lock	F05010-58	2	
7	Bolt, 3/8-16 X 4" Hex Head Grade 2	F05007-4	2	
8	Washer, 3/8" SAE Flat	F05011-3	2	
9	Washer, 3/8" External Star	F05011-36	2	
10	Nut, 3/8" Hex Nylon Lock	F05010-10	2	
11	Washer, 1/4" SAE Flat	F05011-11	2	

<b>12</b>	Nut, 1/4-20 Wing	F05010-13	2	
<b>13</b>	Box Weldment, Battery	015191	1	
<b>14</b>	Fuse Box Parts ( <a href="#">See Section 5.8</a> )			
<b>15</b>	Grommet, 5/8" Rubber Wire	P11764	5	
	Hydraulic Positive Contact Parts ( <a href="#">See Section 10.4</a> )			
<b>16</b>	<b>LID WELDMENT, BATTERY BOX SUPER</b>	015771	1	
<b>17</b>	<b>DECAL, BATTERY BOX LID CAUTION</b>	014774	1	
<b>18</b>	<b>CABLE ASSEMBLY, 1 GA X 12" 150A FUSE TO BATTERY POSITIVE</b>	036308	1	
<b>19</b>	<b>CABLE ASSEMBLY, 1 GA X 16" 225A FUSE TO BATTERY POSITIVE</b>	036309	1	
<b>20</b>	<b>CABLE ASSEMBLY, 1 GA X 26" BATTERY NEGATIVE TO NEG. CONTACT</b>	036306 <sup>3</sup>	1	

<sup>1</sup> Battery changed from Deka 1231PMF to Trojan C31-1000 Rev. J8.03. Battery changed back to Deka 1131XPMF due to discontinuation of Trojan battery.

<sup>2</sup> Battery Box Assembly 015565 modified to include new fuse block and mega fuse Rev. A5.00 ([See Section 5.8](#)).

<sup>3</sup> Replaces 024676 originally supplied (duplicate parts).

## 5.8 Fuse Box Assembly

LT50HD

Rev. A5.00 - A5.02

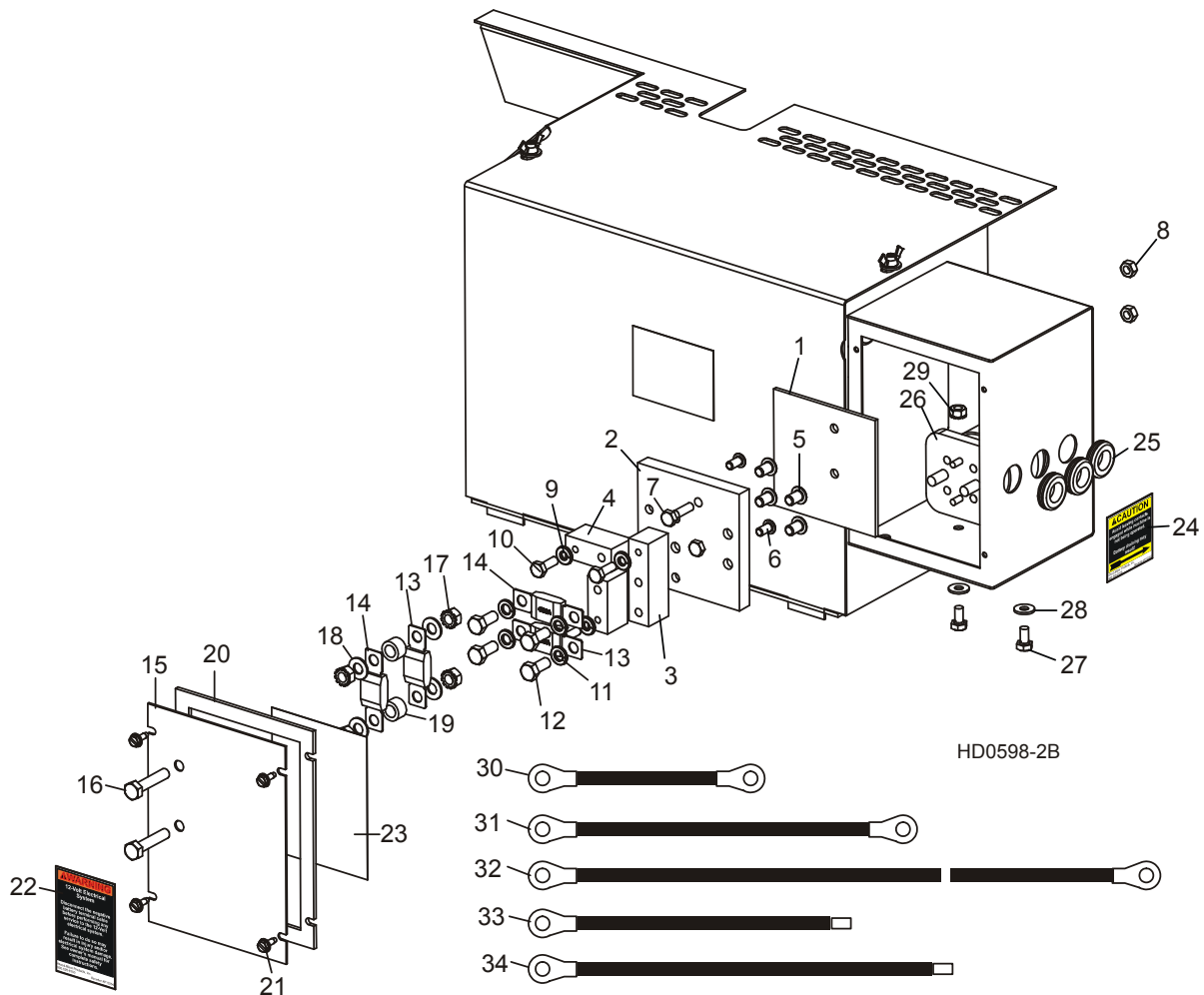

REF	DESCRIPTION (◆ Indicates Parts Available In Assemblies Only)	PART #	QTY.	
	<b>BLOCK ASSEMBLY, DOUBLE FUSE</b>	006795	1	
1	Plate, Fuse Block Insulator	056999	1	
2	Block, Fuse Mount	056997	1	◆
3	Block, 3/4" Upper Fuse	056996	1	
4	Block, 3/4" Lower Fuse	056998	2	
5	Screw, 5/16-18 x 1/2" Socket Button Head	F05006-20	4	
6	Screw, 1/4-20 x 1/2" Socket Button Head	F05005-59	2	
7	Bolt, 1/4-20 x 1" Hex Head Grade 5	F05005-101	2	
8	Nut, 1/4-20 Hex Lock	F05010-21	2	

9	Washer, 1/4" Split Lock	F05011-14	3	
10	Bolt, 1/4-20 x 3/4" Hex Head Grade 5	F05005-123	3	
11	Washer, 5/16" Split Lock	F05011-13	4	
12	Bolt, 5/16-18 x 3/4" Hex Head Grade 5	F05006-102	4	
13	<b>FUSE, 225A 32V MEGA</b>	053339	2	
14	<b>FUSE, 450A 32V MEGA</b>	053340	2	
	<b>COVER ASSEMBLY, DOUBLE FUSE BOX</b>	006853	1	
15	Cover, Fuse Box	006851	1	
16	Bolt, 5/16-18 x 1 1/2" Hex Head Full Thread	F05006-2	2	
17	Nut, 5/16-18 Hex Self-Locking	F05010-20	4	
18	Washer, 5/16" SAE Flat	F05011-17	4	
19	Spacer, .39" x .625" x .39"	055323	2	
20	Gasket, Fuse Box Cover	050283	1	
21	<b>SCREW, #10-24 X 1/2" SELF-TAPPING</b>	F05015-7	4	
22	<b>DECAL, 12 VOLT WARNING</b>	P10364	1	
23	<b>DECAL, 225/450A MEGA FUSE ID</b>	006868	1	
24	<b>DECAL, HYDRAULIC CONTACT CAUTION</b>	P12960	1	
25	<b>GROMMET, 5/8" RUBBER WIRE</b>	P11764	3	
26	<b>SOLENOID KIT, 200A 12V SPST CONT. DUTY</b>	016371	1	
	Solenoid, 200A 12V SPST Cont. Duty	015470	1	◆
	Diode Assembly, Solenoid Coil Chassis Gnd	015426	1	
	<b>WIRE ASSEMBLY, HYDRAULIC SOLENOID VOLTAGE DROP</b>	024451	1	
27	<b>BOLT, 1/4-20 X 1/2" HEX HEAD</b>	F05005-15	2	
28	<b>WASHER, 1/4" SAE FLAT</b>	F05011-11	2	
29	<b>NUT, 1/4-20 SELF-LOCKING HEX</b>	F05010-9	2	
30	<b>CABLE ASSEMBLY, 1 GA X 6 1/2" FUSE TO SOLENOID</b>	036305	1	
31	<b>CABLE ASSEMBLY, 1 GA X 14" SOLENOID TO POSITIVE CONTACT</b>	036307	1	
32	<b>CABLE ASSEMBLY, 1 GA X 26" BATT. NEGATIVE TO GROUND CONTACT</b>	036306	1	
33	<b>CABLE ASSEMBLY, 1 GA X 12" FUSE TO BATTERY POSITIVE</b>	036308	1	
34	<b>CABLE ASSEMBLY, 1 GA X 16" FUSE TO BATTERY POSITIVE</b>	036309	1	

## 5.9 Fuse Box Assembly

LT50HD

Rev. A1.01 - A4.00

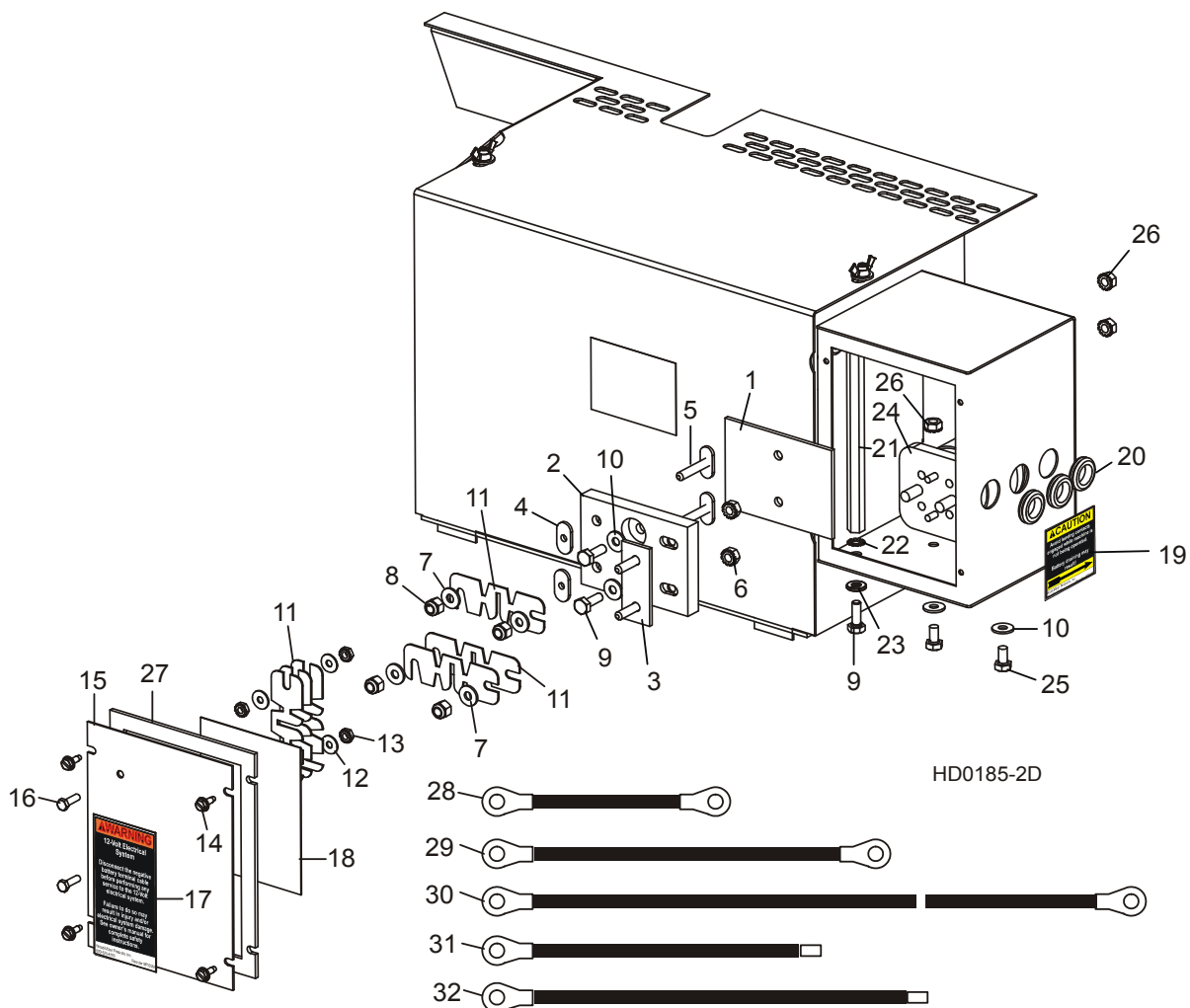

REF	DESCRIPTION (◆ Indicates Parts Available In Assemblies Only)	PART #	QTY.	
1	PAD, FUSE BOX INSULATOR	015287	1	
	<b>FUSE BLOCK ASSEMBLY</b>	017665 <sup>1</sup>	1	
2	Block, Fuse Mount	017664	1	◆
3	Post Weldment, Fuse Mount	017663	1	
4	Nut, 1/4-20 Cadmium Plated Weld	S12392	2	
5	Stud Weldment, 1/4-20 Fuse	W12389	2	
6	Nut, 1/4-20 Self-Locking Hex	F05010-9	2	
7	Washer, 1/4" SAE Flat	F05011-11	4	
8	Nut, 1/4-20 Hex Lock	F05010-21 <sup>2</sup>	4	



9	<b>BOLT, 1/4-20 X 3/4" HEX HEAD FULL THREAD</b>	F05005-1	3	
10	<b>WASHER, 1/4" SAE FLAT</b>	F05011-11	4	
11	<b>FUSE LINK, 12 VOLT 225 AMP</b>	P11550	6	
12	<b>WASHER, #10 SAE FLAT</b>	F05011-18	4	
13	<b>NUT, #10-24 HEX SELF-LOCKING</b>	F05010-14	4	
14	<b>SCREW, #10-24 X 1/2" SELF-TAPPING</b>	F05015-7	4	
15	<b>COVER, FUSE BOX</b>	015282	1	
16	<b>SCREW, #10-24 X 5/8" HEX HEAD</b>	F05004-18	2	
17	<b>DECAL, 12 VOLT WARNING</b>	P10364	1	
18	<b>DECAL, FUSE LINK 225/225A I.D.</b>	017681	1	
19	<b>DECAL, HYDRAULIC CONTACT CAUTION</b>	P12960	1	
20	<b>GROMMET, 5/8" RUBBER WIRE</b>	P11764	3	
21	<b>TERMINAL, EXTENDED HEX STUD</b>	015517	1	
22	<b>WASHER, 1/4" EXTERIOR STAR</b>	F05011-37	1	
23	<b>WASHER, 1/4" SPLIT LOCK</b>	F05011-14	1	
24	<b>SOLENOID KIT, 200A 12V SPST CONT. DUTY</b>	016371	1	
	Solenoid, 200A 12V SPST Cont. Duty	015470	1	◆
	Diode Assembly, Solenoid Coil Chassis Gnd	015426	1	
	<b>WIRE ASSEMBLY, HYDRAULIC SOLENOID VOLTAGE DROP</b>	024451	1	
25	<b>BOLT, 1/4-20 X 1/2" HEX HEAD</b>	F05005-15	2	
26	<b>NUT, 1/4-20 SELF-LOCKING HEX</b>	F05010-9	4	
27	<b>GASKET, FUSE BOX COVER</b>	050283	1	
28	<b>CABLE ASSEMBLY, 1 GA X 6 1/2" FUSE TO SOLENOID</b>	036305	1	
29	<b>CABLE ASSEMBLY, 1 GA X 14" SOLENOID TO POSITIVE CONTACT</b>	036307	1	
30	<b>CABLE ASSEMBLY, 1 GA X 26" BATT. NEGATIVE TO GROUND CONTACT</b>	036306	1	
31	<b>CABLE ASSEMBLY, 1 GA X 12" 150A FUSE TO BATTERY POSITIVE</b>	036308	1	
32	<b>CABLE ASSEMBLY, 1 GA X 16" 225A FUSE TO BATTERY POSITIVE</b>	036309	1	

<sup>1</sup> Battery Box Assembly modified to include new fuse block and mega fuse Rev. A5.00 ([See Section 5.8](#)). Use kit 006906 to retrofit (requires one 225A Mega-Fuse 053339 and one 450A Mega-Fuse 053340 sold separately).

<sup>2</sup> Swaged lock nut F05010-21 replaces Nylon Lock Nut F05010-69 originally supplied prior to 7/08. Heat from the fuses can cause the nylon to melt and the nut to come loose. Nuts and washers added to fuse block kit 017665 11/08.

## SECTION 6 UP/DOWN SYSTEM

### 6.1 Saw Head Mount

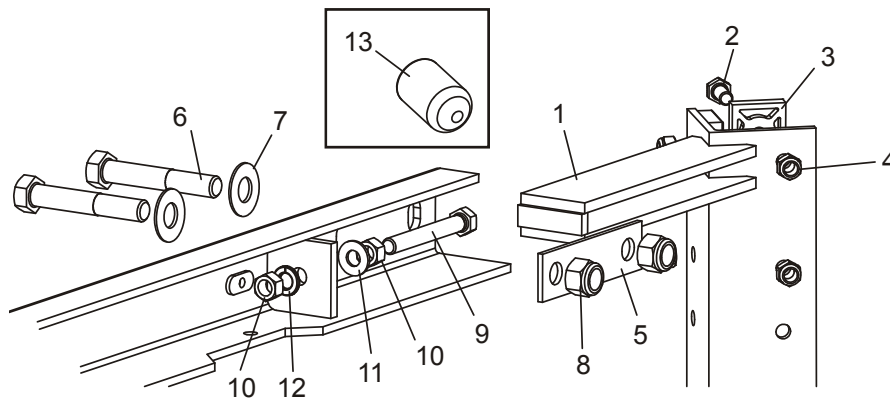

SM0080D

REF	DESCRIPTION (◆ Indicates Parts Available In Assemblies Only)	PART #	QTY.
1	V-BRACE, SAW HEAD MOUNT	W04099	1
2	BOLT, 5/16-18 X 3/4" HEX HEAD GRADE 5	F05006-5	12
	BOLT, 5/16-18 X 1 1/4 HEX HEAD FULL THREAD GRADE 5	F05006-93	4
3	PAD, PLASTIC SLIDE	M04096	6
	PAD, PLASTIC SLIDE LOWER W/CHAMFER	016241	2
4	NUT, 5/16-18 NYLON LOCK	F05010-58	16
5	PLATE, V-BRACE WASHER	S07935	2
6	BOLT, 1/2-13 X 3 1/2" HEX HEAD GRADE 5	F05008-61	4
7	WASHER, 1/2" SAE FLAT	F05011-2	4
8	NUT, 1/2-13 NYLON LOCK	F05010-8	4
9	BOLT, 3/8-16 X 2" FULL THREAD	F05007-17	2
10	NUT, 3/8-16 HEX	F05010-1	4
11	WASHER, 3/8" SAE FLAT	F05011-3	2
12	WASHER, 3/8" SPLIT LOCK	F05011-4	2
13	CAP, .281" X 1/2" BLACK VINYL	017715	3

## 6.2 Blade Height & Quarter Scales

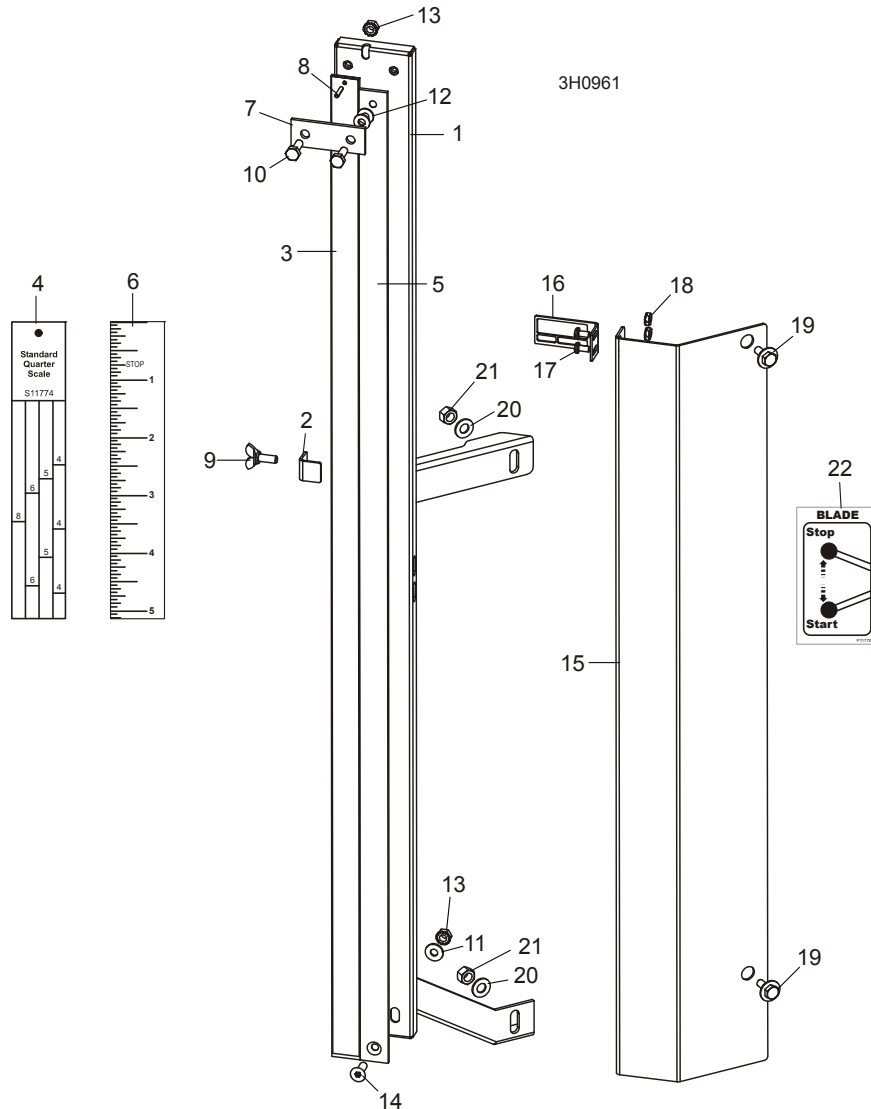

REF	DESCRIPTION (◆ Indicates Parts Available In Assemblies Only)	PART #	QTY.	
	<b>SCALE RETROFIT, FIXED WITH POINTER</b>	A12030	1	
	Scale Kit, Fixed With Pointer	K11998	1	◆
	Scale Assembly, Fixed	A12022	1	◆
1	Bracket, Scale Mounting	W11996	1	
2	Plate, Movable Scale Stop	036666	1	
3	Scale, 35" Quarter	S11989	1	
4	Decal, 35" Standard Quarter Scale	S11774	1	
	Decal, 35" Grade Hardwood Quarter Scale	P12819	1	
5	Scale, 35" Inch	S11988	1	
6	Decal, 35" Inch	S11773	1	

## 6

**Saw Head Mount & Scales***Blade Height & Quarter Scales*

7	Strap, Scale Hold-Down	S04805	1	
8	Pin, 1/8" X 5/8" Roll	F05012-14	1	
9	Screw, 1/4-20 X 5/8" Wing	F05005-64	1	
10	Bolt, 1/4-20 x 1/2" Hex Head	F05005-1	2	
11	Washer, 1/4" SAE Flat	F05011-11	1	
12	Washer, 1/4" X .020 Thick Nylon Flat	F05011-22	2	
13	Nut, 1/4-20 Hex Self-Locking	F05010-9	2	
14	Screw, 1/4-20 X 3/4" Flat Socket Head	F05005-70	1	
	Pointer Assembly, Fixed Scale	038591	1	
15	Bracket, Fixed Scale Pointer Mount	038586	1	
16	Pointer, Fixed Scale	038585	1	
17	Screw, #10-24 X 3/8" Phillips Head	F05004-3	2	
18	Nut, #10-24 Hex Self-Locking	F05010-14	2	
19	Bolt, 1/4-20 x 3/4" with Conical Washer	F05005-134	2	
20	Washer, 5/16" SAE Flat	F05011-17	2	
21	Nut, 5/16-18 Hex Lock	F05010-6	2	
	Bolt, 1/4-20 X 1/2" Hex Head Grade 2	F05005-15	1	
	Instruction Sheet, Fixed Scale Retrofit	A12030-370	1	
	<b>DECAL KIT, METRIC SCALE</b>	K12064	1	
	Decal, Metric	S11711	1	
	Decal, Metric 16-40mm	P12040-1	1	
	Decal, Metric 45-63mm	P12040-2	1	
22	<b>DECAL, CLUTCH HANDLE OPERATION</b>	P11779	1	

### 6.3 Up/Down Chain & Sprockets

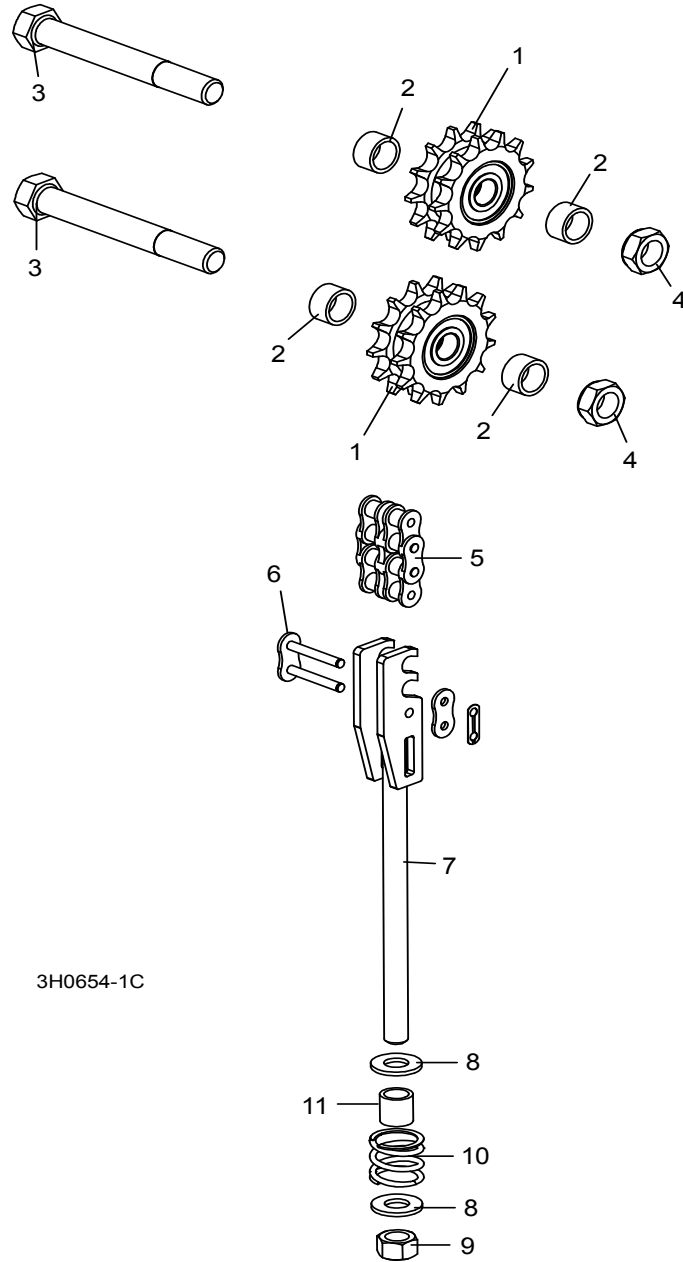

3H0654-1C

REF	DESCRIPTION (◆ Indicates Parts Available In Assemblies Only)	PART #	QTY.
	<b>SPROCKET KIT, UP/DOWN IDLER #50-2</b>	016020	1
1	Sprocket, Up/Down Idler '98	016019	2
2	Spacer, 50-2 Idler '98	016018	4
	Instruction Sheet, Up/Down Idler Retrofit	016020-541	1
3	<b>BOLT, 5/8-11 X 5" HEX HEAD GRADE 2</b>	F05009-6	2

## 6 Up/Down System

### Up/Down Chain & Sprockets

4	<b>NUT, 5/8-11 JAM NYLON LOCK</b>	F05010-96	2	
5	<b>CHAIN, #50-2 X 75.625" UP/DOWN</b>	015259	1	
6	<b>LINK, #50-2 MASTER</b>	015258	2	
	<b>TENSIONER ASSEMBLY, UP/DOWN CHAIN</b>	015456	1	
7	Bracket, Up/Down #50 Chain Tensioner	015188	1	◆
8	Washer, 1/2" SAE Flat	F05011-2	2	
9	Nut, 1/2-13 Hex Lock	F05010-3 <sup>1</sup>	1	
10	Spring, 1" OD x 1" Long x .125" Wire Compression	016516	1	
11	Spacer, Up/Dn Chain Tensioner	016515	1	

<sup>1</sup> Swaged lock nut F05010-3 has always been used in production instead of Nylon Lock Nut F05010-8 (9/09).

## 6.4 Up/Down Motor Assembly

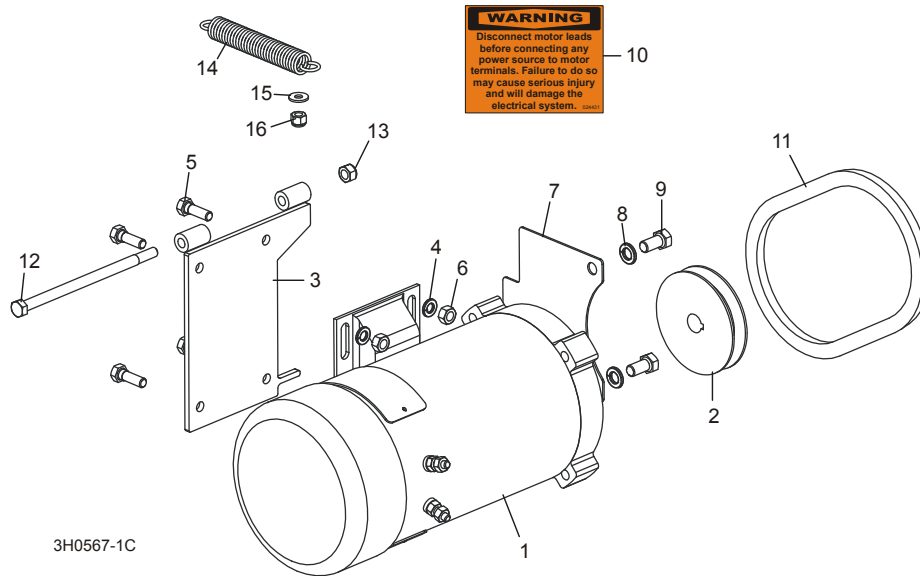

REF	DESCRIPTION (◆ Indicates Parts Available In Assemblies Only)	PART #	QTY.
	<b>UP/DOWN MOTOR ASSEMBLY</b>	036209	1
1	Motor, 3/4 HP Electric	015174	1
	Brush Kit, Power Feed Motor (Includes 2 Brushes and 2 Springs)	024167	1
	Fan, 3/4 HP Leeson Motor Replacement	016087	1
	Guard, Motor Fan	047998	1
2	Pulley, AK28 x 5/8"	033852	1
3	Bracket, Up/Down Motor Mount	015198	1
4	Washer, 5/16" Split Lock	F05011-13	4
5	Bolt, 5/16-18 x 1" Hex Head	F05006-1	4
6	Nut, 5/16-18 Hex	F05010-17	4
7	Guard, Up/Down Sprocket	015016	1
8	Washer, 3/8" Split Lock	F05011-4	2
9	Bolt, 3/8-16 x 3/4" Hex Head	F05007-27	2
10	Decal, Disconnect Motor Leads Warning	024431	1
11	<b>BELT, 4L245 NOTCHED</b>	038459	1
12	<b>BOLT, 5/16-18 X 6" HEX HEAD GRADE 5</b>	F05006-73	1
13	<b>NUT, 5/16-18 HEX NYLON LOCK</b>	F05010-65	1
14	<b>SPRING, .75" X 3 3/4" X .092" EXTENSION</b>	015569	1
15	<b>WASHER, 1/4" SAE FLAT</b>	F05011-11	1
16	<b>NUT, 1/4-20 NYLON LOCK HEX</b>	F05010-69	1

## 6.5 Up/Down Drive Assembly

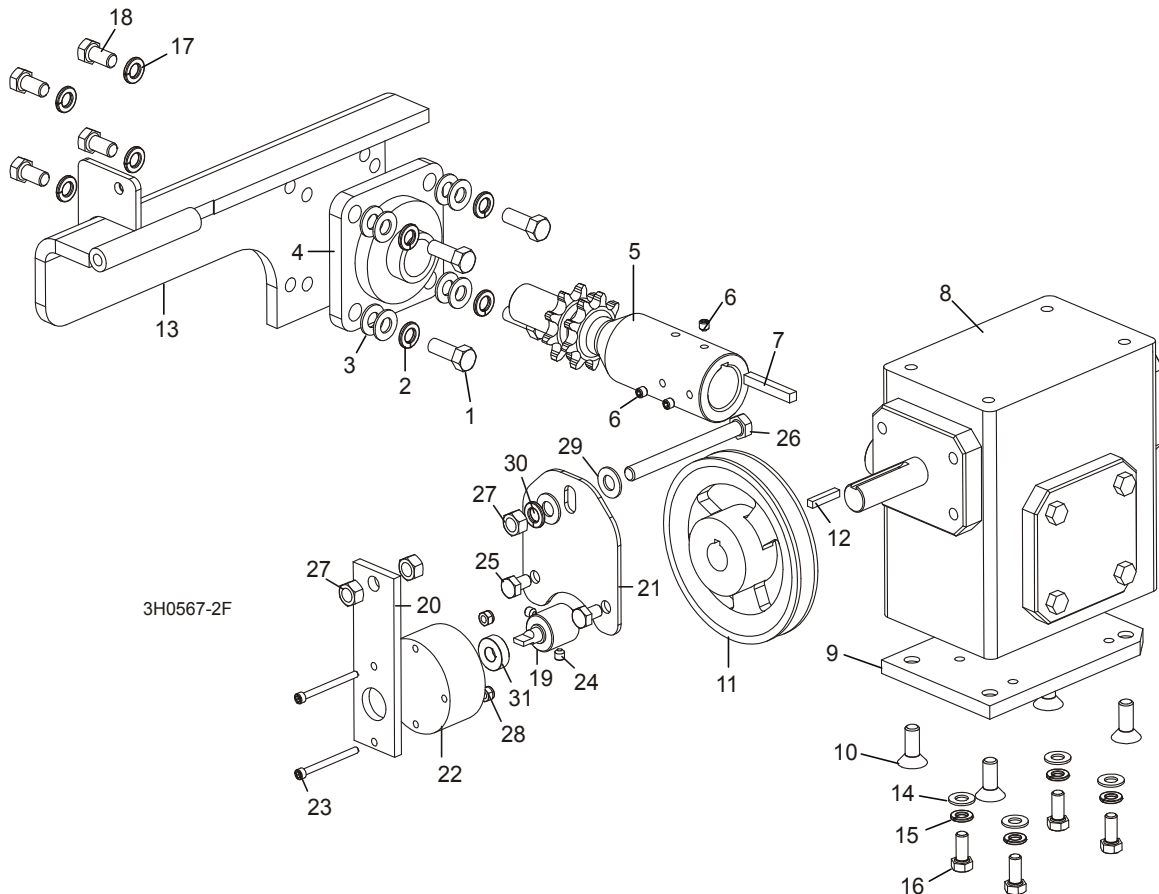

REF	DESCRIPTION (◆ Indicates Parts Available In Assemblies Only)	PART #	QTY.	
	<b>UP/DOWN DRIVE ASSEMBLY</b>	015176	1	
1	Bolt, 3/8-16 x 1" Hex Head	F05007-7	4	
2	Washer, 3/8" Split Lock	F05011-4	4	
3	Washer, 3/8" SAE Flat	F05011-3	8	
4	Bearing, Flanged Up/Down	014090	1	
	Shaft Kit, Up/Down Drive	016094	1	
5	Shaft, Up/Down Sprocket	016031	1	◆
6	Screw, 1/4-28 x 1/4" Socket Head Cup Point	F05005-105 <sup>1</sup>	3	
7	Key, 1/4" Square x 1 11/16" Long	S04124	1	
8	Reducer, Gear Box	014074	1	
9	Plate, Gear Box Spacer	014158	1	
10	Bolt, 3/8-16 x 1" Flat Socket Head	F05007-64	4	
11	Pulley, Up/Down	015256	1	
12	Key, 3/16" Square x 1" Long	S31027	1	
13	Bracket, Up/Down Motor Mount	015195	1	



14	<b>WASHER, 5/16" SAE FLAT</b>	F05011-17	4	
15	<b>WASHER, 5/16" SPLIT LOCK</b>	F05011-13	4	
16	<b>BOLT, 5/16-18 X 3/4" HEX HEAD GRADE 5</b>	F05006-102	4	
17	<b>WASHER, 3/8" SPLIT LOCK</b>	F05011-4	4	
18	<b>BOLT, 3/8-16 X 3/4" HEX HEAD</b>	F05007-27	4	
	<b>OIL, 8 OZ. MOBIL SHC634 BOTTLED SYNTHETIC GEAR</b>	L04869-4 <sup>2</sup>	1	
	<b>BRAKE ASSEMBLY, SUPER UP/DOWN</b>	065187 <sup>3</sup>	1	
19	Shaft, Up/Down Brake	062567	1	
20	Plate, Brake Mount	062513	1	
21	Plate, Super Up/Dn Brake Mount	065190	1	
	Brake Assembly, LT40/50/70 Up/Down Replacement	065907	1	
22	Brake, Klauber Gearmotor #K01134D300	069519	1	◆
	Terminal, 3/16" 18-22 Ga Quick Male	F05708-26	2	
23	Bolt, #8-32 x 2" Socket Head Stainless Steel	F05004-273	2	
24	Screw, 1/4-20 x 1/4" Cup Point Socket Set	F05005-131	2	
25	Bolt, 5/16-18 x 1/2" Hex Head Grade 5	F05006-15	2	
26	Bolt, 3/8-16 x 4" Hex Head Full Thread Grade 5	F05007-92	1	
27	Nut, 3/8-16 Hex	F05010-1	3	
28	Nut, #8-32 Hex Nylon Lock	F05010-169	2	
29	Washer, 3/8" SAE Flat	F05011-3	2	
30	Washer, 3/8" Split Lock	F05011-4	1	
31	Bearing, R6-2NSL SRI-2 ABEC-1	P10688	1	

<sup>1</sup> One F05005-105 replaces two F05004-76 #10-24 x 3/8" Cup Point Set Screws supplied prior to 7/07.

<sup>2</sup> 24 oz. required for complete oil replacement.

<sup>3</sup> Brake added 2/11 to prevent saw head from drifting during sawing. Use retrofit kit 062570 to retrofit previous revisions.

## SECTION 7 FEED SYSTEM & TRACK ROLLERS

### 7.1 Upper Track Rollers And Wipers

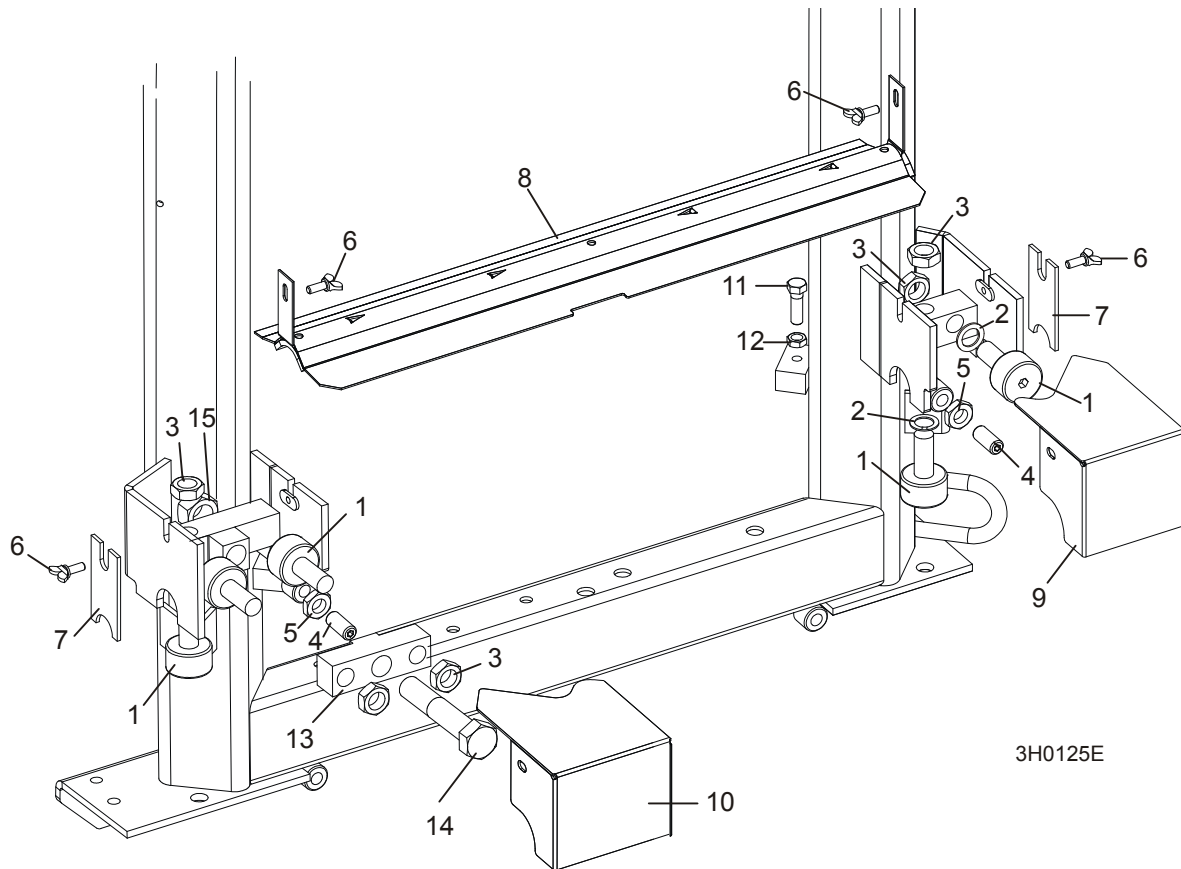

REF	DESCRIPTION (◆ Indicates Parts Available In Assemblies Only)	PART #	QTY.	
1	ROLLER, TRACK CAM BEARING	012797	5	
2	SHIM, 5/8" X 1" X .062"	016510	2	
3	NUT, 5/8-18 HEX JAM	F05010-11	5	
4	SCREW, 1/2-13 X 1 1/4" OVAL POINT SET	F05008-5	2	
5	NUT, 1/2-13 HEX JAM	F05010-31	2	
6	SCREW, 1/4-20 X 5/8" THUMB	F05005-64	4	
7	WIPER, PLASTIC TRACK	M04113	2	
8	COVER, MIDDLE TRACK OILER ASSEMBLY	A09918	1	
	Cover, Middle Track Oiler	S09917	1	◆
	Wiper, Middle Track Felt	S09915	1	
9	HOUSING, UPPER TRACK ROLLER REAR	012999	1	
10	HOUSING, UPPER TRACK ROLLER FRONT	016285	1	
11	BOLT, 3/8-16 X 1 1/4" HEX HEAD	F05007-2	2	
12	NUT, 3/8-16 HEX JAM	F05010-29	2	

**Feed System & Track Rollers**  
*Upper Track Rollers And Wipers*

**7**

---

13	BLOCK, UPPER ROLLER PIVOT	016501	1	
14	BOLT, 3/4-10 X 4" HEX HEAD GRADE 5	F05013-3	1	
15	NUT, 3/4-10 SELF LOCKING	F05010-80	1	

# 7 Feed System & Track Rollers

## Power Feed Assembly

### 7.2 Power Feed Assembly

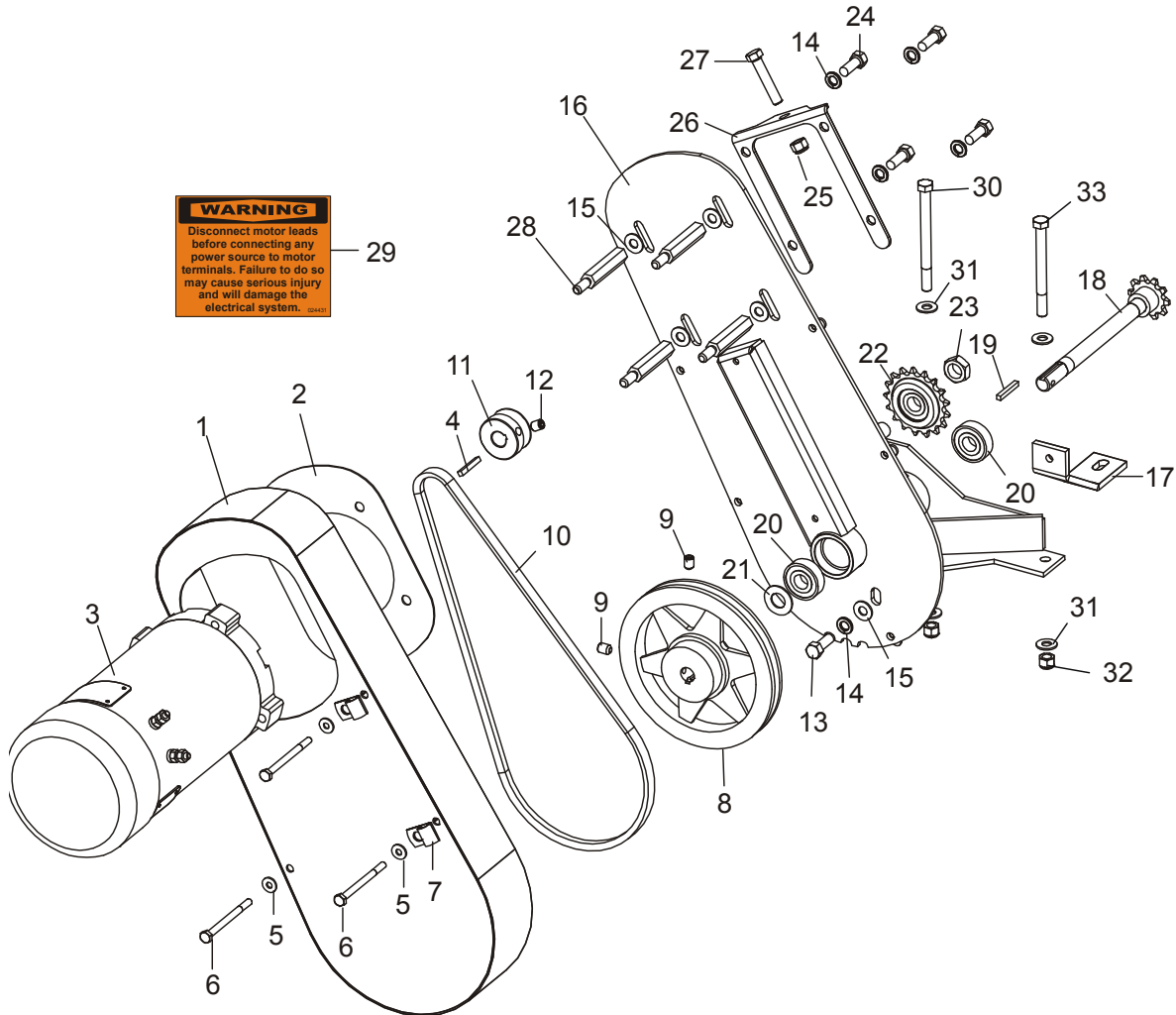

3H0814-1C

REF	DESCRIPTION (◆ Indicates Parts Available In Assemblies Only)	PART #	QTY.
	<b>POWER FEED ASSEMBLY</b>	015125	1
1	Cover Weldment, Top Power Feed	015126	1
2	Plate, Power Feed Motor	015133	1
3	Motor, 3/4HP Power Feed Painted	024169	1
	Brush Kit, Leeson 3/4HP Motor (Includes 2 Brushes and 2 Springs)	024167	1
	Fan, 3/4 HP Leeson Motor Replacement	016087	1
	Guard, Motor Fan	047998	1
	Hub, Motor Fan Extension	047999	1
4	Key, 3/16" Square x 1" Long	S31027	1
5	Washer, 1/4" SAE Flat	F05011-11	4
6	Bolt, 1/4-20 X 3 1/2" Hex Head Grade 2	F05005-54	4

## Feed System & Track Rollers

*Power Feed Assembly*

7

7	Clamp, 5/8" EMT Coated	010748	2	
8	Sheave, AK71 x 5/8" Power Feed (200ft./min.)	016088 <sup>1</sup>	1	
9	Screw, 5/16-18 x 3/4" Cup Point Set	F05006-32	2	
10	Belt, AX36 (200ft./min.)	016083 <sup>1</sup>	1	
11	Sheave, 1 3/4" Feed Motor	015135	1	
12	Screw, 3/8"-16 x 1/2" Cup Point Set	F05007-12	1	
13	Bolt, 3/8-16 x 1" Hex Head	F05007-7	1	
14	Washer, 3/8" Split Lock	F05011-4	5	
15	Washer, 3/8" Flat	F05011-3	5	
16	Bracket, Power Feed Mount	015162	1	
17	Brace, Power Feed Mounting	015132	1	
	Shaft Assembly, Power Feed with Key	016066	1	
18	Shaft Weldment, Power Feed	015129	1	◆
19	Key, 3/16" Square x 1 3/8" Long	016108	1	
20	Bearing, 5/8" 6203-2NSL	P06030-1	2	
21	Washer, 5/8" x 15/16" x .094" Nylon	F05011-19	1	
22	Sprocket, #40/41 Idler 17T 5/8" ID w/Bearing	016366	1	
23	Nut, 5/8-11 Nylon Lock Jam	F05010-96	1	
24	Bolt, 3/8-16 x 3/4" Hex Head	F05007-27	4	
25	Nut, 3/8-16 Hex Nylon Lock	F05010-10	1	
26	Plate, Belt Tensioner	015134	1	
27	Bolt, 3/8-16 x 2" Full Thread Hex Head	F05007-16	1	
28	Spacer, Power Feed Motor	015136	4	
29	Decal, Disconnect Motor Leads Warning	024431	1	
30	<b>BOLT, 3/8-16 X 4 1/2" HEX HEAD</b>	F05007-35	1	
31	<b>WASHER, 3/8" SAE FLAT</b>	F05011-3	4	
32	<b>NUT, 3/8-16 HEX NYLON LOCK</b>	F05010-10	2	
33	<b>BOLT, 3/8-16 X 4" FULL THREAD HEX HEAD TAP GRADE 5</b>	F05007-4	1	

<sup>1</sup> To increase feed return rate to 220 ft./min. replace with AK64 sheave 016114 and AX35 belt 015175 (replaces kit 016085). Kit 016070, AL84 x 5/8" Sheave 016115 and AX38 Belt 016068 to reduce feed return rate to 183 ft./min. no longer available.

### 7.3 Feed Chain/Stop

LT50HD

Rev. A3.00 - A5.02

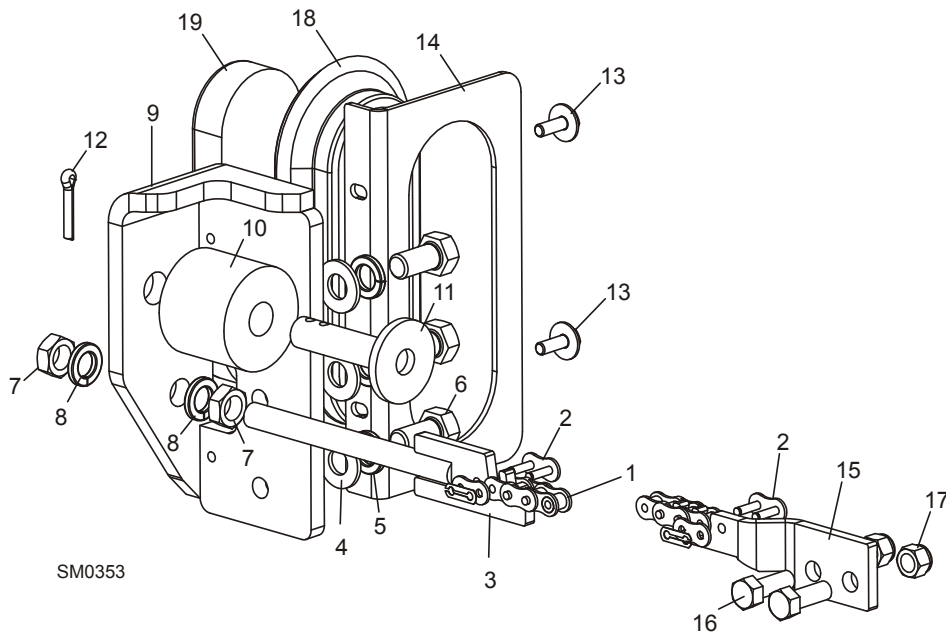

REF	DESCRIPTION (◆ Indicates Parts Available In Assemblies Only)	PART #	QTY.
1	CHAIN, #40 X 267.5" LT40 FEED	014745	1
2	LINK, #40 MASTER	P04200	2
3	TENSIONER WELDMENT, POWER FEED CHAIN	015721	1
4	WASHER, 1/2" SAE FLAT	F05011-2	3
5	WASHER, 1/2" SPLIT LOCK	F05011-9	3
6	BOLT, 1/2-13 X 1" HEX HEAD GRADE 8	F05008-128	3
7	NUT, 1/2-20 HEX JAM	F05010-16	2
8	WASHER, 1/2" SPLIT LOCK	F05011-9	2
9	BRACKET WELDMENT, REAR FEED STOP	006686	1
	STOP KIT, RUBBER CARRIAGE	K09630	2
10	Stop, Rubber Carriage	P12165	1
11	Pin, Rubber Carriage Stop	W09293	1
12	Pin, 3/16" X 1" Cotter	F05012-21	1
13	BOLT, 1/4-20 X 3/4" WITH CONICAL WASHER	F05005-134	1
14	PLATE, BED TUBE END W/LIGHT MOUNT	057822	1
15	BRACKET, FRONT FEED CHAIN MOUNT	015008	1
16	BOLT, 3/8-16 X 1" HEX HEAD	F05007-7	2
17	NUT, 3/8-16 HEX NYLON LOCK	F05010-10	2
18	GROMMET, 6 1/2" LIGHT MOUNTING	006688	1
19	LIGHT, 8 DIODE LED TAIL	006391	1

## 7.4 Feed Chain/Stop

LT50HD

Rev. A1.01 - A2.02

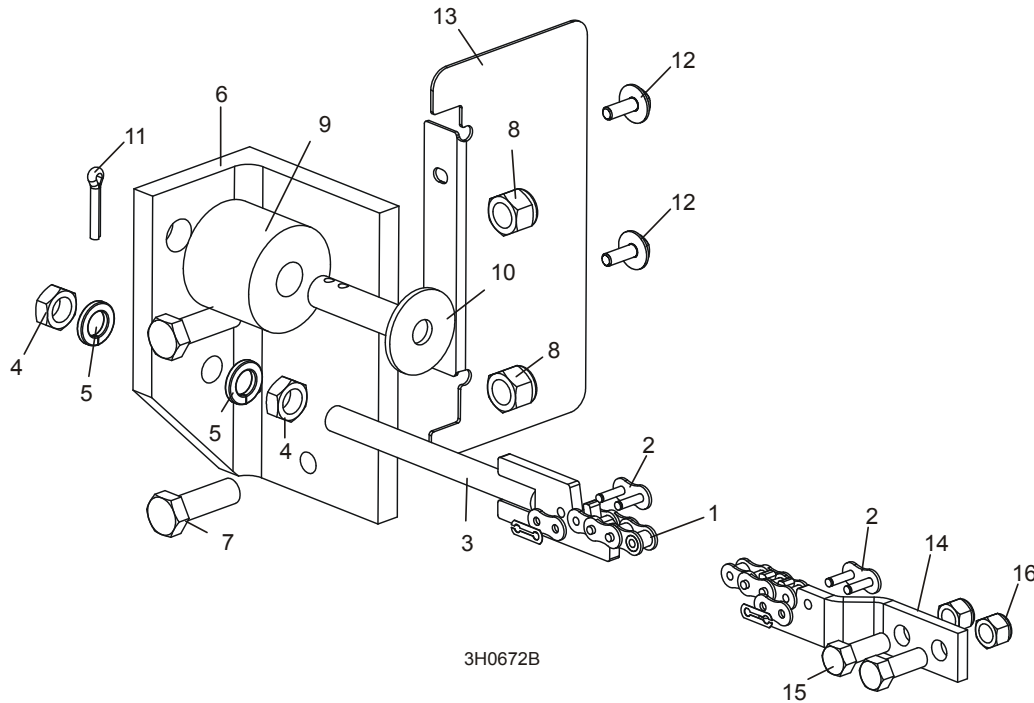

3H0672B

REF	DESCRIPTION (◆ Indicates Parts Available In Assemblies Only)	PART #	QTY.
1	CHAIN, #40 X 267.5" LT40 FEED	014745	1
2	LINK, #40 MASTER	P04200	2
3	TENSIONER WELDMENT, POWER FEED CHAIN	015721	1
4	NUT, 1/2-20 HEX JAM	F05010-16	2
5	WASHER, 1/2" SPLIT LOCK	F05011-9	2
6	BRACKET, 4 X 8 END CAP	016165	1
7	BOLT, 1/2-13 X 1 1/2" HEX HEAD GRADE 5	F05008-33	2
8	NUT, 1/2-13 HEX NYLON LOCK	F05010-8	2
	STOP KIT, RUBBER CARRIAGE	K09630	2
9	Stop, Rubber Carriage	P12165	1
10	Pin, Rubber Carriage Stop	W09293	1
11	Pin, 3/16" X 1" Cotter	F05012-21	1
12	BOLT, 1/4-20 X 3/4" WITH CONICAL WASHER	F05005-134	1
13	CAP, 4 X 8" REAR FORMED	016164	1
14	BRACKET, FRONT FEED CHAIN MOUNT	015008	1
15	BOLT, 3/8-16 X 1" HEX HEAD	F05007-7	2
16	NUT, 3/8-16 HEX NYLON LOCK	F05010-10	2

## 7.5 Lower Track Rollers

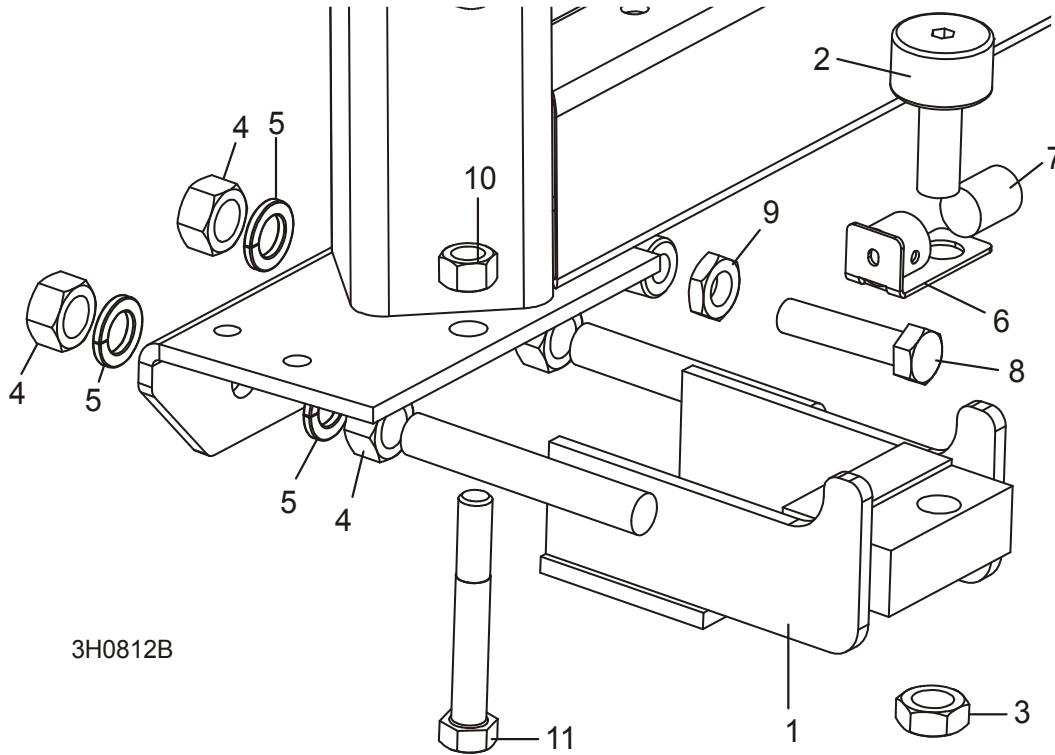

REF	DESCRIPTION (◆ Indicates Parts Available In Assemblies Only)	PART #	QTY.	
	<b>ROLLER ASSEMBLY, LOWER TRACK</b>	012995	2	
1	Bracket, Lower Track Roller Mounting	012982	1	◆
2	Roller, Track Cam Bearing	012797	1	
3	Nut, 5/8-18 Hex Jam	F05010-11	1	
4	Nut, 5/8-11 Hex	F05010-5	4	
5	Washer, 5/8" Split Lock Grade 8	F05011-118 <sup>1</sup>	4	
6	Bracket Weldment, Lower Track Roller Wiper	033374	1	
7	Wiper, Round Gray Felt	033375	1	
8	<b>BOLT, 1/2-13 X 2 1/4" HEX HEAD FULL THREAD</b>	F05008-2	2	
9	<b>NUT, 1/2-13 HEX JAM</b>	F05010-31	2	
10	<b>NUT, 1/2-13 HEX LOCK</b>	F05010-3	2	
11	<b>BOLT, 1/2-13 X 3 1/2" HEX HEAD GRADE 5</b>	F05008-61	2	

<sup>1</sup> Grade 8 washers replace F05011-27 originally supplied before 8/07 to improve durability.



## SECTION 8 BED FRAME ASSEMBLY

### 8.1 Bed Rail Assembly, Front And Rear

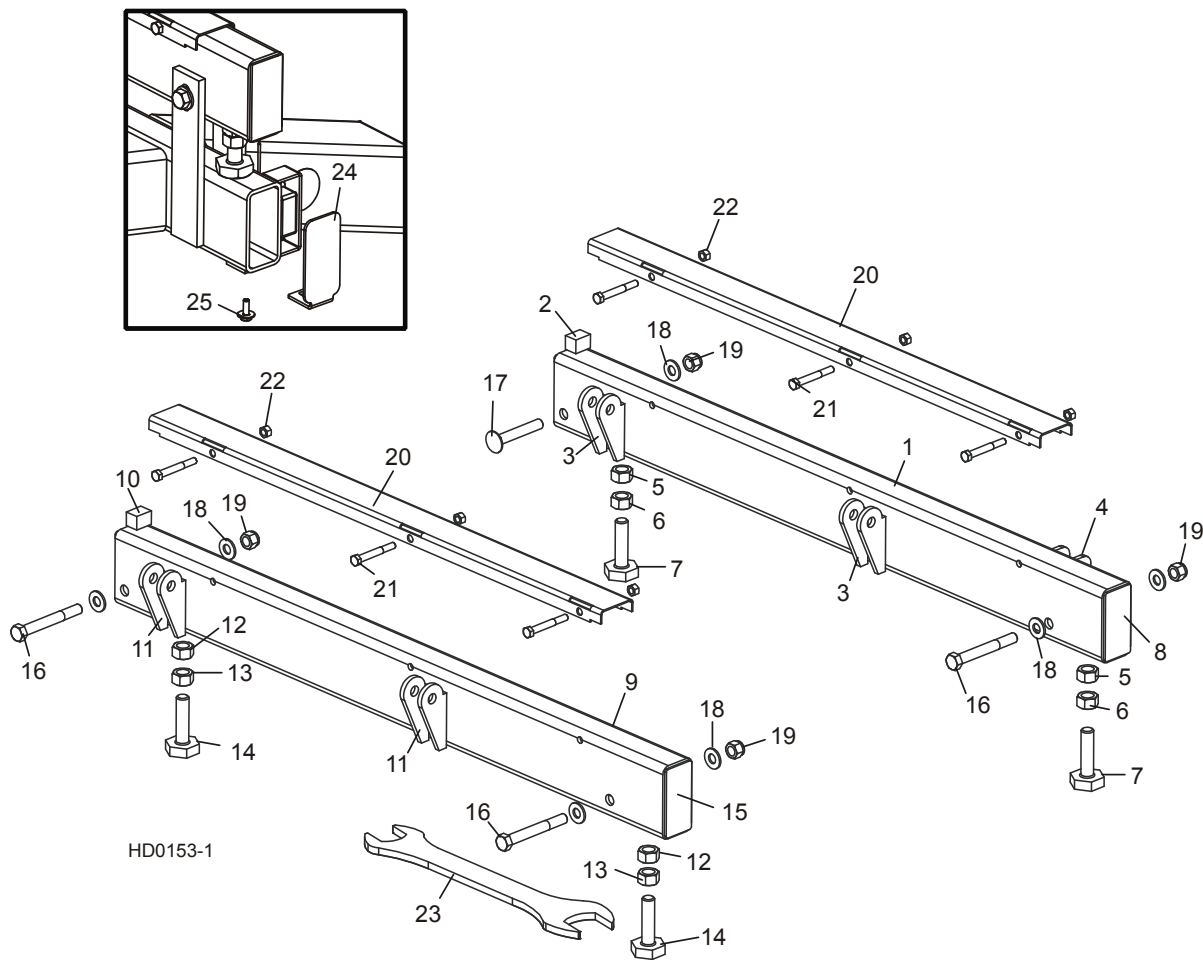

HD0153-1

REF	DESCRIPTION (◆ Indicates Parts Available In Assemblies Only)	PART #	QTY.	
	<b>BED RAIL ASSEMBLY, REAR PAINTED</b>	014467	1	
1	Bed Rail Tube, Long	015974	1	◆
2	Block, Log Stop	S09034	1	
3	Bracket, Roller Toe Board Mount	S13021	4	◆
4	Bracket, Saw Head Rest Pin Mount	014150	2	◆
5	Nut, 5/8-11 Pilot Weld	F05010-84	2	
6	Nut, 5/8-11 Hex	F05010-5	2	
7	Bolt, Bed Rail Adjustment	S13006	2	
8	Plate, Bed Rail End Cap	S04058	2	◆
	<b>BED RAIL ASSEMBLY, FRONT PAINTED</b>	014455	1	
9	Bed Rail Tube, Long	015974	1	◆

## 8

**Bed Frame Assembly***Bed Rail Assembly, Front And Rear*

10	Block, Log Stop	S09034	1	
11	Bracket, Roller Toe Board Mount	S13021	4	◆
12	Nut, 5/8-11 Pilot Weld	F05010-84	2	
13	Nut, 5/8-11 Hex	F05010-5	2	
14	Bolt, Bed Rail Adjustment	S13006	2	
15	Plate, Bed Rail End Cap	S04058	2	◆
16	<b>BOLT, 1/2-13 X 4" HEX HEAD</b>	F05008-78	3	
17	<b>BOLT, 1/2-13 X 3 1/2" CARRIAGE</b>	F05008-94 <sup>1</sup>	1	
18	<b>WASHER, 1/2" SAE FLAT</b>	F05011-2	7	
19	<b>NUT, 1/2-13 NYLON LOCK</b>	F05010-8	4	
20	<b>COVER, STAINLESS STEEL BED RAIL</b>	016898	2	
21	<b>BOLT, 5/16-18 X 2 1/2" HEX HEAD</b>	F05006-10	6	
22	<b>NUT, 5/16-18 HEX LOCK</b>	F05010-6	6	
23	<b>WRENCH, BED RAIL ADJUSTMENT</b>	015970	1	
24	<b>CAP, BED RAIL REMOVABLE END</b>	038843	2	
25	<b>BOLT, 1/4-20 X 3/4" W/CONICAL WASHER HEAD</b>	F05005-134	2	

<sup>1</sup> Used on rear bed rail to allow clearance for side support rollers.

## 8.2 Bed Rail Assembly, Middle Front

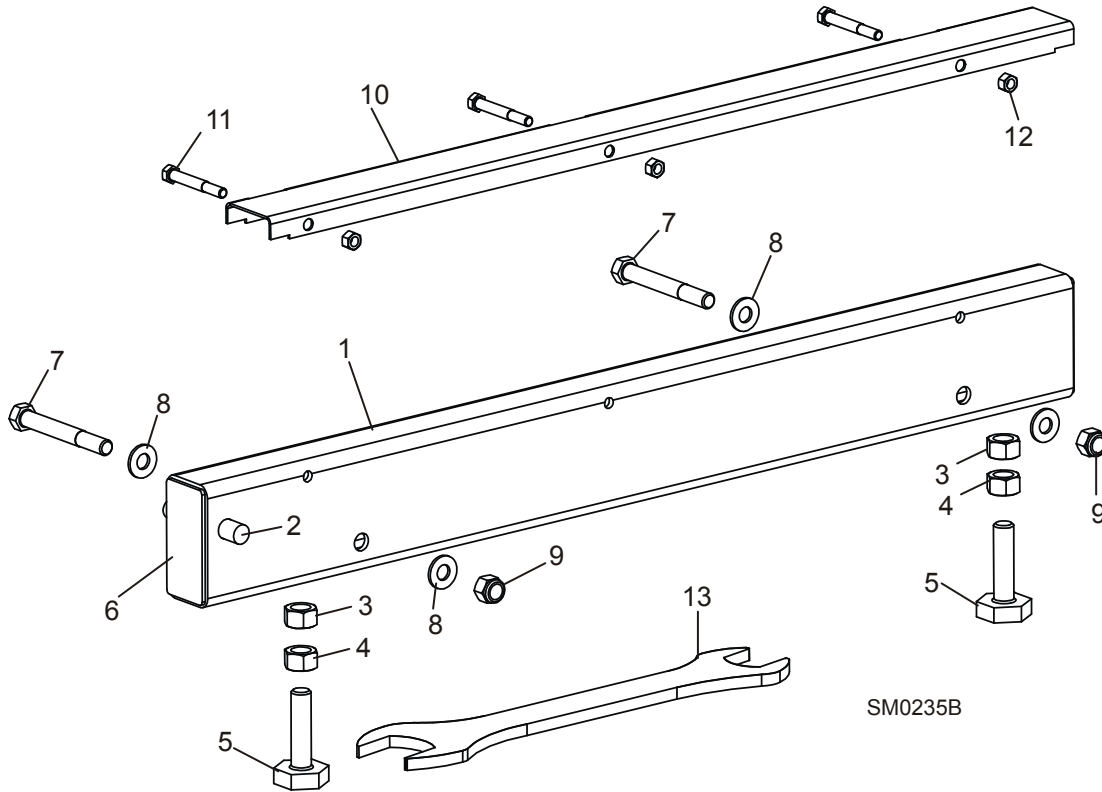

REF	DESCRIPTION (◆ Indicates Parts Available In Assemblies Only)	PART #	QTY.	
	<b>BED RAIL ASSEMBLY, FRONT MIDDLE</b>	A09566	1	
1	Bed Rail Tube, Short	S09103	1	◆
2	Pin, Ramp Mount	S04030	1	
3	Nut, 5/8-11 Pilot Weld	F05010-84	2	
4	Nut, 5/8-11 Hex	F05010-5	2	
5	Bolt, Bed Rail Adjustment	S13006	2	
6	Plate, Bed Rail End Cap	S04058	2	◆
7	<b>BOLT, 1/2-13 X 4" HEX HEAD GRADE 5</b>	F05008-78	2	
8	<b>WASHER, 1/2" SAE FLAT</b>	F05011-2	4	
9	<b>NUT, 1/2-13 NYLON LOCK</b>	F05010-8	2	
	<b>COVER ASSEMBLY, STAINLESS STEEL BED RAIL (LONG)</b>	A09956	1	
10	Cover, Stainless Steel Bed Rail	S09944	1	◆
11	Bolt, 5/16-18 X 2 1/2" Hex Head	F05006-10	3	
12	Nut, 5/16-18 Hex Lock	F05010-6	3	
13	<b>WRENCH, BED RAIL ADJUSTMENT</b>	015970	1	

# 8 Bed Frame Assembly

## Bed Rail Assembly, Middle Rear

### 8.3 Bed Rail Assembly, Middle Rear

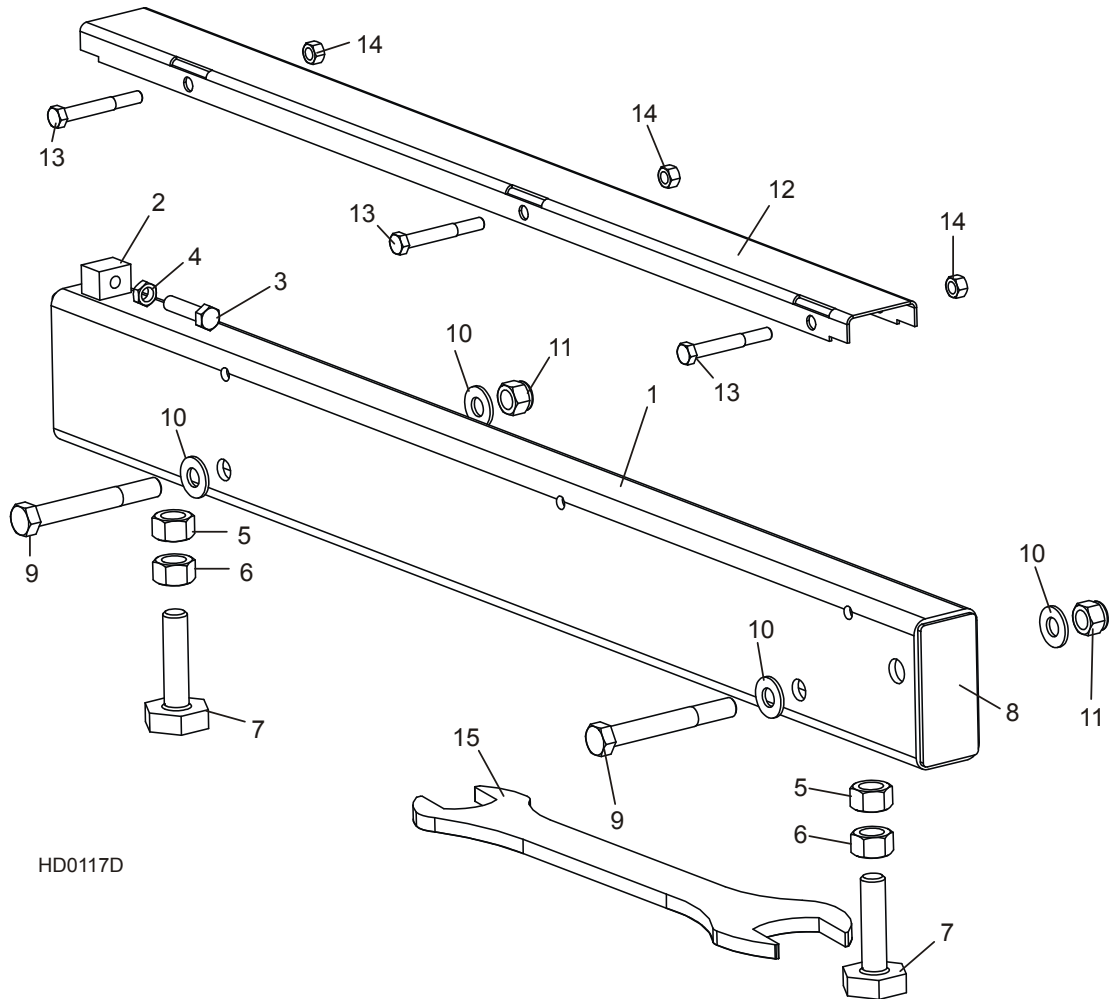

REF	DESCRIPTION (◆ Indicates Parts Available In Assemblies Only)	PART #	QTY.	
	<b>BED RAIL ASSEMBLY, REAR MIDDLE PAINTED</b>	015757	1	
1	Bed Rail Tube, Short	014640	1	◆
2	Block, Log Stop w/Threaded Hole	014639	1	◆
3	Bolt, 3/8-16 x 1 1/2 Full Thead Hex Head	F05007-17	1	
4	Nut, 3/8-16 Hex Jam	F05010-29	1	
5	Nut, 5/8-11 Square Pilot Weld	F05010-187	2	
6	Nut, 5/8-11 Hex	F05010-5	2	
7	Bolt, Bed Rail Adjustment	S13006	2	
8	Plate, Bed Rail End Cap	S04058	1	
9	<b>BOLT, 1/2-13 X 4" HEX HEAD GRADE 5</b>	F05008-78	2	
10	<b>WASHER, 1/2" SAE FLAT</b>	F05011-2	4	
11	<b>NUT, 1/2-13 NYLON LOCK</b>	F05010-8	2	

**Bed Frame Assembly**  
*Bed Rail Assembly, Middle Rear*

**8**

	<b>COVER ASSEMBLY, STAINLESS STEEL BED RAIL (LONG)</b>	A09956	1	
<b>12</b>	Cover, Stainless Steel Bed Rail	S09944	1	◆
<b>13</b>	Bolt, 5/16-18 X 2 1/2" Hex Head	F05006-10	3	
<b>14</b>	Nut, 5/16-18 Hex Lock	F05010-6	3	
<b>15</b>	<b>WRENCH, BED RAIL ADJUSTMENT</b>	015970	1	

# 8 Bed Frame Assembly

## Leg Assembly (Stationary)

### 8.4 Leg Assembly (Stationary)

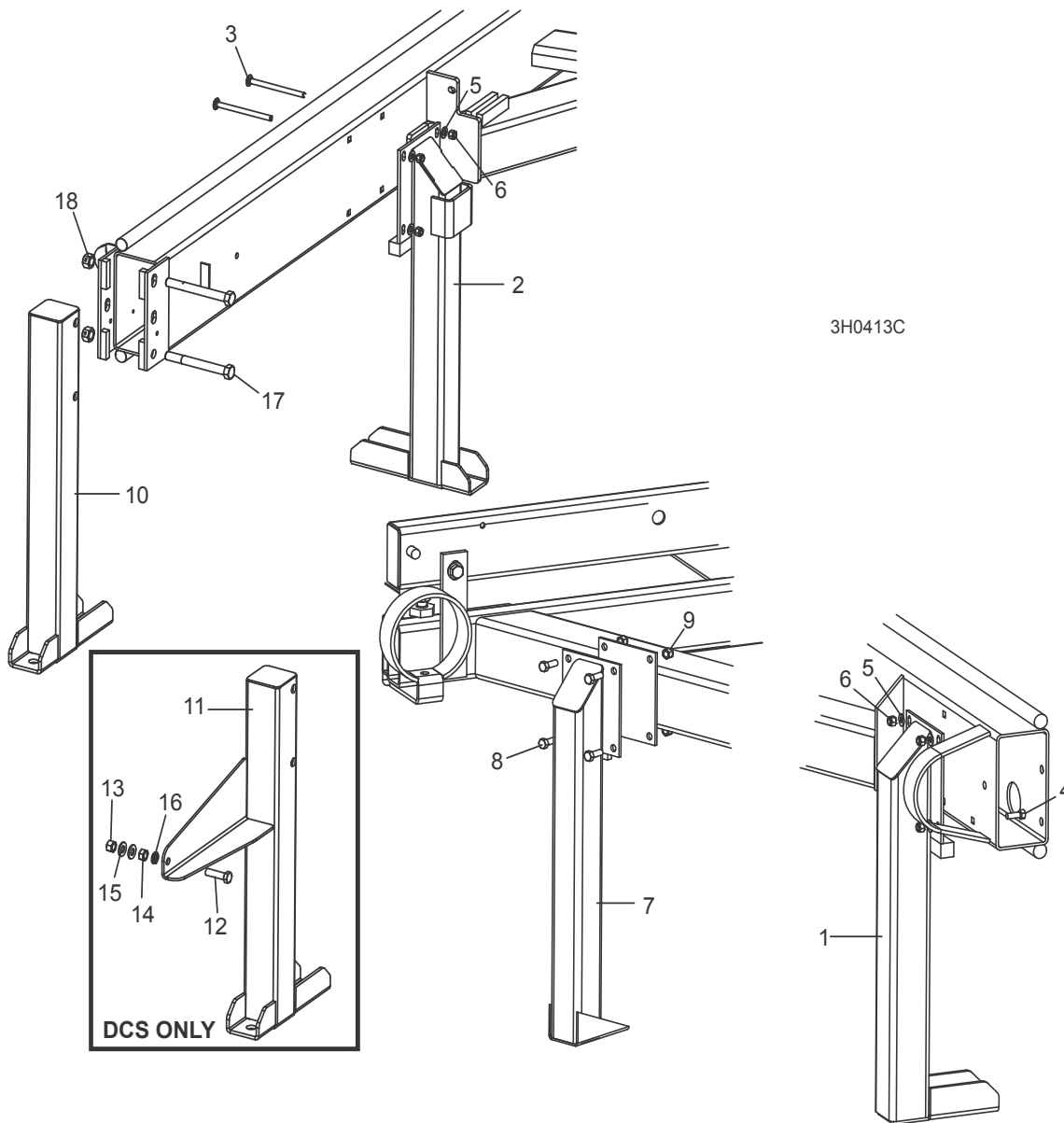

REF	DESCRIPTION (◆ Indicates Parts Available In Assemblies Only)	PART #	QTY.
1	LEG, LONG STATIONARY	W09513	3
2	LEG, LONG STATIONARY W/BOARD RETURN TABLE BRACKET	015091	1
3	BOLT, 3/8-16 X 5" CARRIAGE HEAD	F05007-113	12
4	BOLT, 3/8-16 X 1 1/4" HEX HEAD	F05007-2	4
5	WASHER, 3/8" SAE FLAT	F05011-3	16
6	NUT, 3/8-16 HEX NYLON LOCK	F05010-10	16

**Bed Frame Assembly**  
*Leg Assembly (Stationary)*

**8**

7	LEG, SHORT STATIONARY	W09515	2	
8	BOLT, 3/8-16 X 1 1/4" HEX HEAD	F05007-2	8	
9	NUT, 3/8-16 HEX NYLON LOCK	F05010-10	8	
10	LEG, FRONT STATIONARY	W09517	1	
11	BOLT, 5/8-11 X 5 1/2" HEX HEAD GRADE 5	F05009-11	2	
12	NUT, 5/8-11 HEX LOCK	F05010-4	2	

# 8 Bed Frame Assembly

## Board Return Table Assembly

### 8.5 Board Return Table Assembly

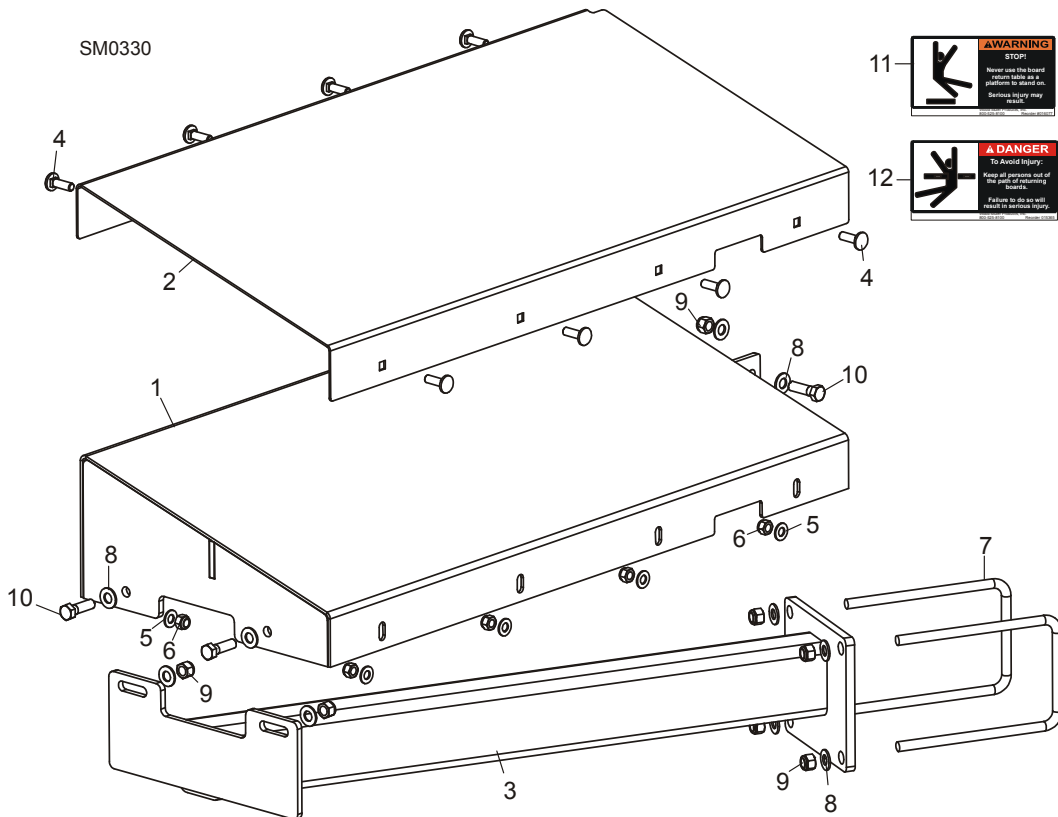

REF	DESCRIPTION (◆ Indicates Parts Available In Assemblies Only)	PART #	QTY.
	<b>TABLE ASSEMBLY, BOARD RETURN</b>	003264	1
1	Table Weldment, Board Return	055515	1
2	Cover, Board Return Table	003259	1
3	Mount Weldment, Board Return Table	055533	1
4	Bolt, 5/16-18 x 1" Carriage Head	F05006-9	8
5	Washer, 5/16" SAE Flat	F05011-17	8
6	Nut, 5/16-18 Nylon Lock	F05010-58	8
7	Bolt, 3/8-16 x 4" x 5" 'U'	003207	2
8	Washer, 3/8" SAE Flat	F05011-3	10
9	Nut, 3/8-16 Hex Nylon Lock	F05010-10	7
10	Bolt, 3/8-16 x 1 1/4" Hex Head Grade 5	F05007-123	3
11	Decal, Board Return Table Warning	016077	1
12	Decal, Board Return Danger	015365	1



### 8.6 Pivot Bed Rail Assembly

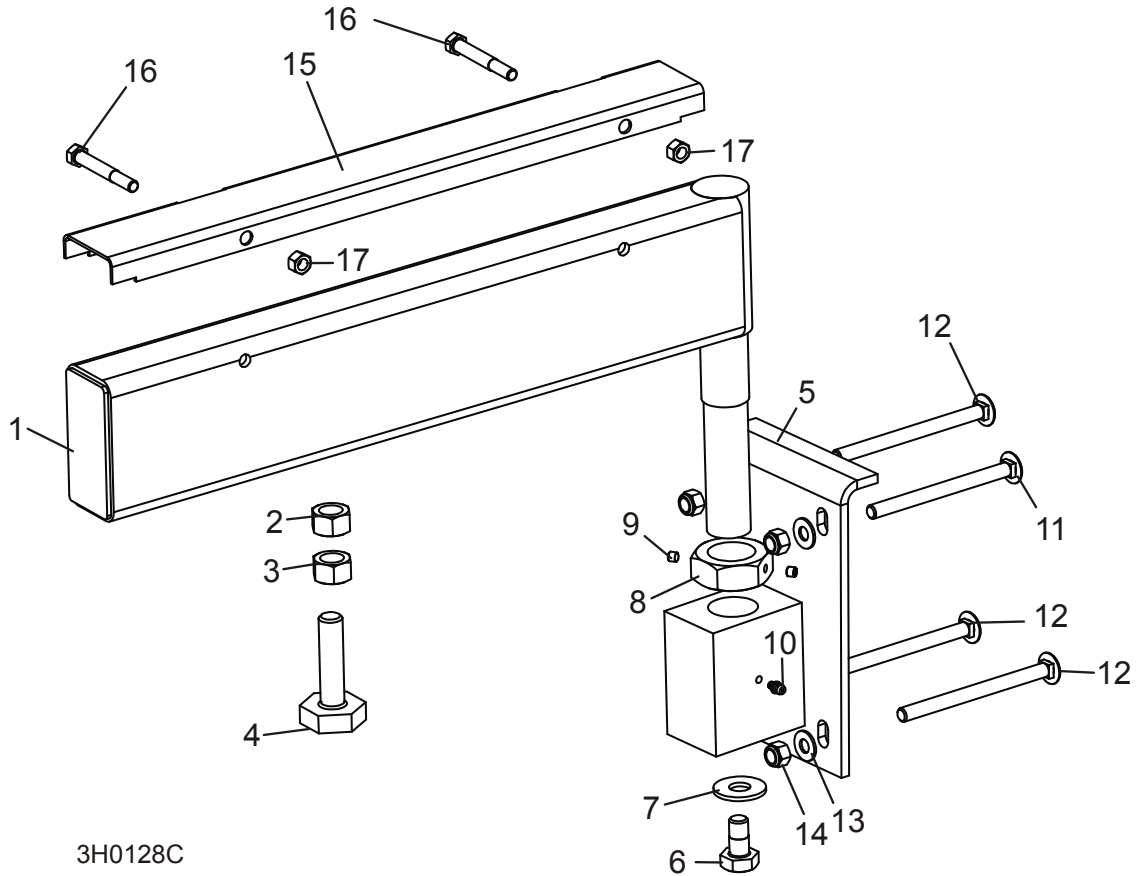

3H0128C

REF	DESCRIPTION (◆ Indicates Parts Available In Assemblies Only)	PART #	QTY.	
	<b>PIVOT BED RAIL ASSEMBLY</b>	A13015	2	
1	Pivot Bed Rail Weldment	W13014	1	◆
2	Nut, 5/8-11 Pilot Weld	F05010-84	2	
3	Nut, 5/8-11 Hex	F05010-5	2	
4	Bolt, Bed Rail Adjustment	S13006	2	
5	Bracket, Pivot Rail Mounting	W13090	1	
6	Bolt, 1/2-13 x 1" Hex Head Grade 2	F05008-50	1	
7	Washer, 9/16" SAE Flat	F05011-52	1	
8	Nut, Pivot Rail Adjustment	S13016	1	
9	Screw, 1/4-28 x 1/4" Brass Tip Set	F05005-42	2	
10	Fitting, 3/16" Grease	P04107	1	
11	<b>BOLT, 3/8-16 X 4 3/4" CARRIAGE HEAD</b>	F05007-114	2	
12	<b>BOLT, 3/8-16 X 5" CARRIAGE HEAD</b>	F05007-113	6	
13	<b>WASHER, 3/8" SAE FLAT</b>	F05011-3	8	

**8****Bed Frame Assembly***Pivot Bed Rail Assembly*

---

<b>14</b>	<b>NUT, 3/8-16 NYLON LOCK</b>	F05010-10	8	
	<b>COVER KIT, PIVOT RAIL STAINLESS STEEL ()</b>	017710	2	
<b>15</b>	Cover, Stainless Steel Pivot Bed Rail ()	S13012	1	
<b>16</b>	Bolt, 5/16-18 X 2 1/2" Hex Head	F05006-10	2	
<b>17</b>	Nut, 5/16-18 Hex Lock	F05010-6	2	
	<b>WRENCH, BED RAIL ADJUSTMENT (<a href="#">See Section 8.1</a>)</b>	015970	1	

## 8.7 Safety Chain Assembly

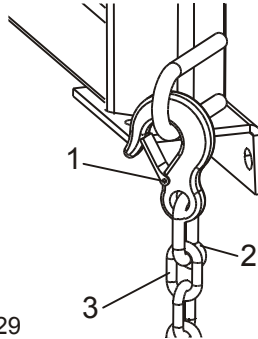

REF	DESCRIPTION (◆ Indicates Parts Available In Assemblies Only)	PART #	QTY.	
	<b>CHAIN ASSEMBLY, TIE DOWN</b>	A04376	1	
1	Hook, 5/8" Safety Chain	P12075	1	◆
2	Cold Shut, 3/8" Plain	P04772-2	1	◆
3	Chain, 5/16" Unplated	R02111	.938 ft.	◆

**8** **Bed Frame Assembly**  
*Saw Head Rest Pin Assembly*

**8.8 Saw Head Rest Pin Assembly**

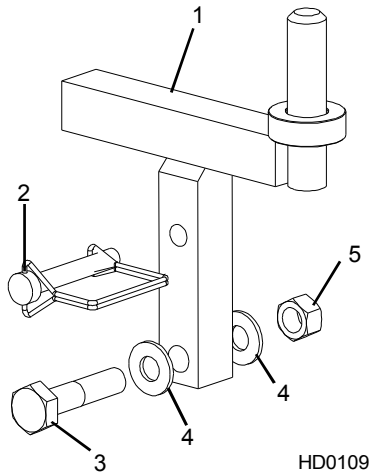

REF	DESCRIPTION (◆ Indicates Parts Available In Assemblies Only)	PART #	QTY.	
1	PIN, SAW HEAD REST	014102	1	
2	PIN, 3/8" X 2 1/4" SNAP RETAINER	014151	1	
3	BOLT, 1/2-13 X 2 1/4" HEX HEAD GRADE 5	F05008-10	1	
4	WASHER, 1/2" SAE FLAT	F05011-2	2	
5	NUT, 1/2-13 HEX LOCK	F05010-3	1	

## 8.9 Bed Frame Decals

LT50HD

Rev. A2.00 (1/08) - A5.02

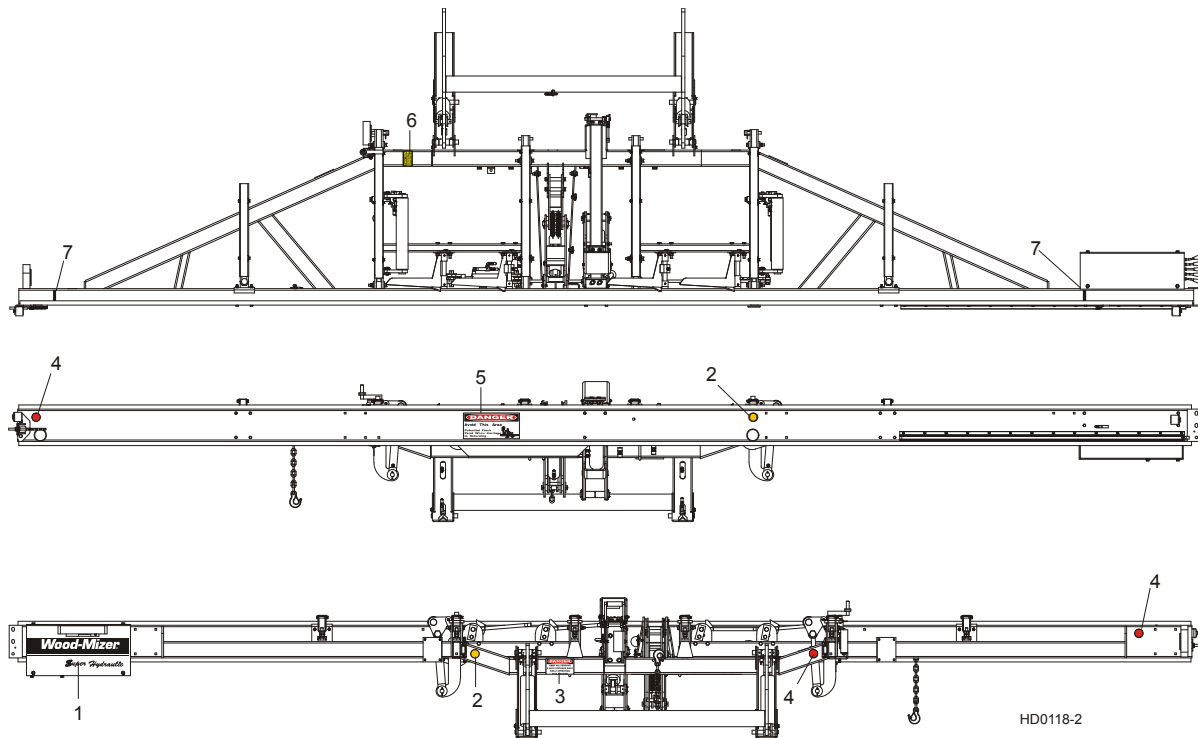

REF	DESCRIPTION (◆ Indicates Parts Available In Assemblies Only)	PART #	QTY.
1	DECAL, WOOD-MIZER LT50HD LOGO	003252	1
2	DECAL, AMBER REFLECTIVE 2" ROUND	P07453	2
3	DECAL, KEEP AWAY DANGER	S09851	1
4	DECAL, RED REFLECTIVE 2" ROUND	P07452	3
5	DECAL, PINCH POINT DANGER	P10287	1
6	DECAL, SAW HEAD REST CAUTION	S12581	1
7	DECAL, LOG LIMIT STRIPE	S12051	2

# 8 Bed Frame Assembly

## Bed Frame Decals

### 8.10 Bed Frame Decals

LT50HD

Rev. A1.01 - A2.00 (12/07)

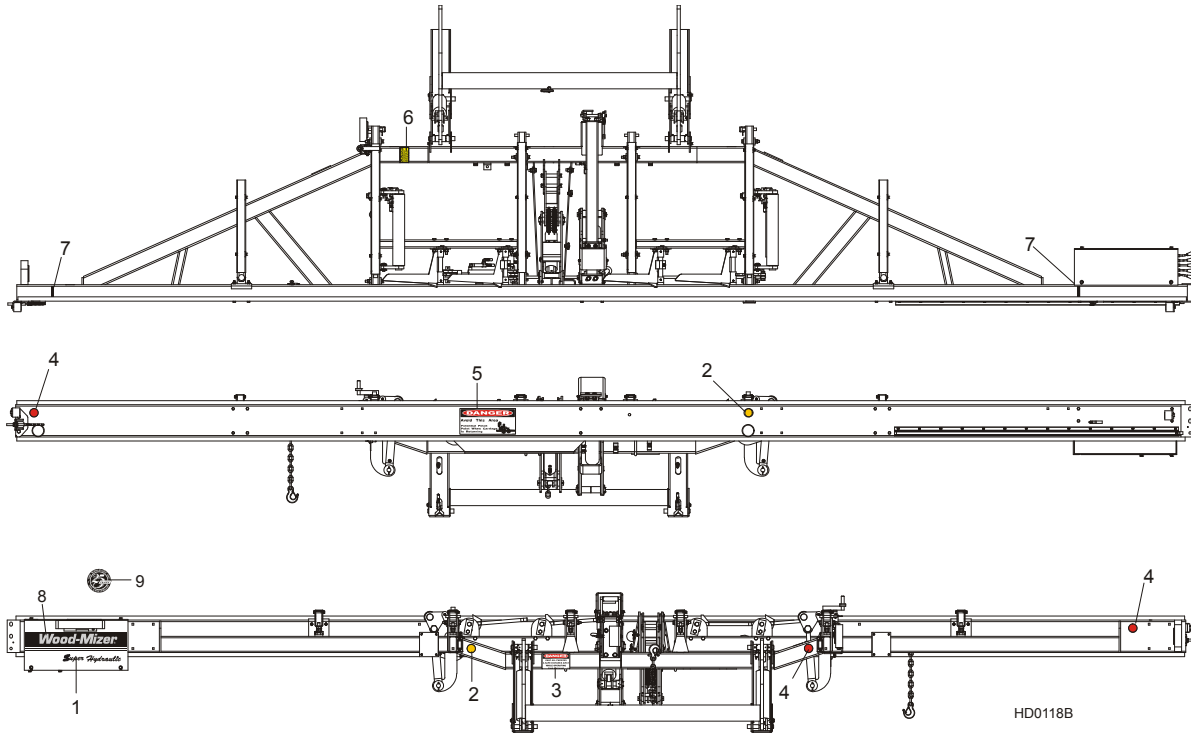

REF	DESCRIPTION (◆ Indicates Parts Available In Assemblies Only)	PART #	QTY.
1	DECAL, WOOD-MIZER LT50HD LOGO	003252	1
2	DECAL, AMBER REFLECTIVE 2" ROUND	P07453	2
3	DECAL, KEEP AWAY DANGER	S09851	1
4	DECAL, RED REFLECTIVE 2" ROUND	P07452	3
5	DECAL, PINCH POINT DANGER	P10287	1
6	DECAL, SAW HEAD REST CAUTION	S12581	1
7	DECAL, LOG LIMIT STRIPE	S12051	2
8	DECAL, SILVER WOOD-MIZER LOGO	003234	1
9	DECAL, ANNIVERSARY LOGO	003237	1

### 8.11 Board Outfeed Table (Optional)

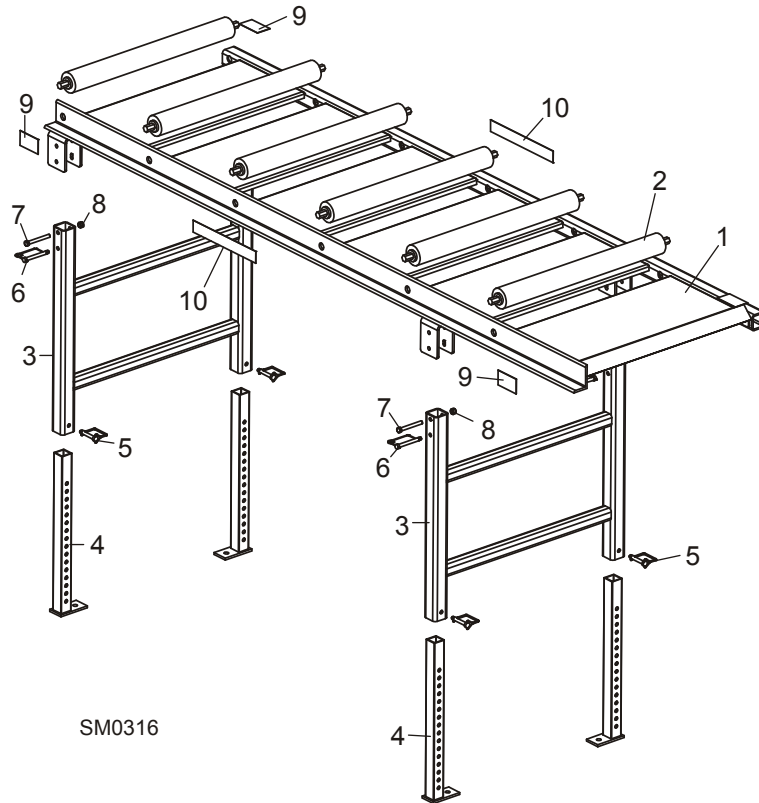

REF	DESCRIPTION (◆ Indicates Parts Available In Assemblies Only)	PART #	QTY.
	<b>TABLE ASSEMBLY, BOARD OUTFEED</b>	016652	1
1	Table Weldment, Board Outfeed	016606	1
2	Roller, 2 1/2" x 25"	038167	6
3	Mount Weldment, Outfeed Table Leg	016609	2
4	Leg Weldment, Outfeed Table	016651	4
5	Pin, 3/8" x 2 1/4" Square Wire Lock	014151	4
6	Pin, Snap - Coil Tension	016677	4
7	Bolt, 3/8-16 x 3 1/4" Hex Head	F05007-135	4
8	Nut, 3/8-16 Hex Nylon Lock	F05010-10	4
9	Decal, Hand Pinch Point Warning	S12641	4
10	Decal, 1 1/2" Wood-Mizer Logo	016991	2

## SECTION 9 MISCELLANEOUS

### 9.1 Replacement Manuals

REF	DESCRIPTION (◆ Indicates Parts Available In Assemblies Only)	PART #	QTY.
<b>Wood-Mizer Product Information</b>			
1	ALL-PRODUCTS CATALOG	PS750	1
<b>Basic Sawmill Manuals</b>			
2	TRU-SHARP BLADE HANDBOOK	M600	1
3	WOOD-MIZER GENERAL INFORMATION	M601	1
4	LT50HD OPERATOR'S MANUAL	M1298	1
5	LT50HD-WR WIRELESS OPERATOR'S MANUAL	M1546	1
6	LT50HD PARTS MANUAL	M1300	1
7	LT50HD-WR WIRELESS PARTS MANUAL	M1548	1
<b>Power Option Manuals</b>			
8	E25 MOTOR OPTION MANUAL	M772	1
9	G38 ENGINE OPTION MANUAL	M1305	1
10	D47 ENGINE OPTION MANUAL	M1584	1
11	D51 ENGINE OPTION MANUAL	M1163	1
<b>Trailer Option Manuals</b>			
12	ELECTRIC BRAKE TRAILER OPTION	M796	1
13	SURGE BRAKE TRAILER OPTION	M794	1
14	SUPER ELECTRIC BRAKE TRAILER OPTION	M797	1
15	SUPER SURGE BRAKE TRAILER OPTION	M795	1
<b>Miscellaneous Option Manuals</b>			
16	SHINGLE/LAPSIDER OPTION MANUAL	M621	1
17	OPERATOR'S SEAT OPTION MANUAL	M613	1
18	RESAW ATTACHMENT OPTION MANUAL	M263	1
19	BED EXTENSION OPTION MANUAL	M294	1
20	MKII DEBARKER ATTACHMENT OPTION MANUAL	M546	1
21	ACCUSET 2 OPTION MANUAL	M1517	1
22	ACCUSET OPTION MANUAL	M987	1
23	LASER SIGHT OPTION MANUAL	M679	1
24	AUTOCLUTCH OPTION MANUAL	M883	1
25	LUBE-MIZER OPTION MANUAL	M885	1
26	LATHE-MIZER OPTION MANUAL	M1337	1
<b>Electrical Diagrams</b>			
27	G38 SUPER ELECTRICAL INFORMATION	M1306	1
28	G38-WR WIRELESS ELECTRICAL INFORMATION	M1555	1
29	E25 ELECTRICAL INFORMATION	M863	1
30	E25-WR WIRELESS ELECTRICAL INFORMATION	M1554	1
31	D47 ELECTRICAL INFORMATION	M1585	1
32	D47-WR WIRELESS ELECTRICAL INFORMATION	M1587	1
33	D51 ELECTRICAL INFORMATION	M1164	1



34	D51-WR WIRELESS ELECTRICAL INFORMATION	M1553	1
----	--	-------	---

## SECTION 10 HYDRAULIC SYSTEM

### 10.1 Hydraulic Hoses

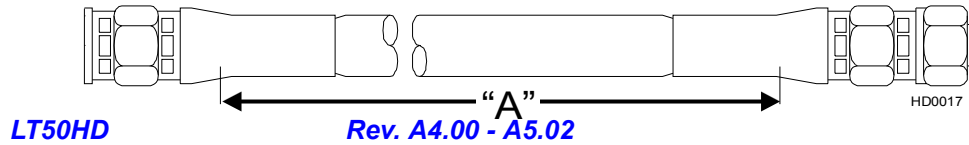

ID	Color Code	LENGTH "A"	Application	PART #
H1	Purple	219"	1/4" Rear Toe Board Top	018026
H2	Black	219"	1/4" Rear Toe Board Base	018026
H3	Yellow	117"	1/4" Front Toe Board Top	P12542
H4	Gray	117"	1/4" Front Toe Board Base	P12542
H5	Green	204"	1/4" Clamp Up/Down Top	014792
H6	Yellow	193"	1/4" Clamp Up/Down Base	015692
H7	Red	178"	3/8" Loading Arm Base	048291
H8	Blue	178"	3/8" Loading Arm Top	048291
H9	Orange	65"	3/8" Side Support Base	048292
H10	Plain	73"	3/8" Side Support Top	048293
H11	Orange	177"	3/8" Clamp In/Out Base	048295
H12	White	151"	3/8" Clamp In/Out Top	048297
H13	Green	38"	3/8" Loading Arm Branch Top	006875 <sup>1</sup>
H14	Green	77"	3/8" Loading Arm Branch Top	048298
H15	Yellow	81"	3/8" Loading Arm Branch Base	048299
H16	Yellow	43"	3/8" Loading Arm Branch Base	048300
H17	Plain	181"	3/8" Log Turner Base	048294
H18	Pink	181"	3/8" Log Turner Top	048294
H19	Purple	177"	3/8" Log Turner Motor (Nearest Frame)	006723
H20	Black	180"	3/8" Log Turner Motor (Furthest from Frame)	006724
H21	Plain	15"	1/4" Pump To Valve (two hoses)	057964
H22	Plain	6 1/2"	3/8" Gauge To Valve	036303

<sup>1</sup> Replaces 048292 supplied prior to 11/08. 048292 was modified to 65" for new log turner.

## 10.2 Hydraulic Hoses

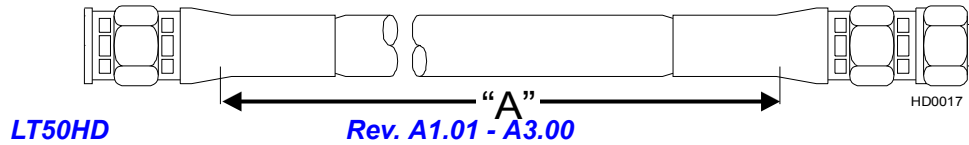

ID	Color Code	LENGTH "A"	Application	PART #
H1	Purple	219"	1/4" Rear Toe Board Top	018026
H2	Black	219"	1/4" Rear Toe Board Base	018026
H3	Yellow	117"	1/4" Front Toe Board Top	P12542
H4	Gray	117"	1/4" Front Toe Board Base	P12542
H5	Green	204"	1/4" Clamp Up/Down Top	014792
H6	Yellow	193"	1/4" Clamp Up/Down Base	015692
H7	Red	178"	3/8" Loading Arm Base	048291
H8	Blue	178"	3/8" Loading Arm Top	048291
H9	Orange	65"	3/8" Side Support Base	048292 <sup>1</sup>
H10	Plain	73"	3/8" Side Support Top	048293 <sup>1</sup>
H11	Orange	177"	3/8" Clamp In/Out Base	048295
H12	White	151"	3/8" Clamp In/Out Top	048297
H13	Green	38"	3/8" Loading Arm Branch Top	006875 <sup>2</sup>
H14	Green	77"	3/8" Loading Arm Branch Top	048298
H15	Yellow	81"	3/8" Loading Arm Branch Base	048299
H16	Yellow	43"	3/8" Loading Arm Branch Base	048300
H17	Plain	181"	3/8" Log Turner Base	048294
H18	Pink	181"	3/8" Log Turner Top	048294
H19	Purple	186"	3/8" Log Turner Motor Top	048303
H20	Black	185"	3/8" Log Turner Motor Base	048305
H21	Plain	15"	1/4" Pump To Valve (two hoses)	057964 <sup>3</sup>
H22	Plain	6 1/2"	3/8" Gauge To Valve	036303

<sup>1</sup> Hoses lengthened 7" to accommodate new log turner 11/08.

<sup>2</sup> Replaces 048292 supplied prior to 11/08. 048292 was modified to 65" for new log turner.

<sup>3</sup> Hose kit 057964 replaces individual hoses 036292 originally supplied prior to 6/08. Kit includes two hoses and instructions to reroute the hoses to avoid abrasion against pump motor terminal which can expose the steel braids and cause an electrical short ([See Form #1570](#)).

### 10.3 Hydraulic Control Box

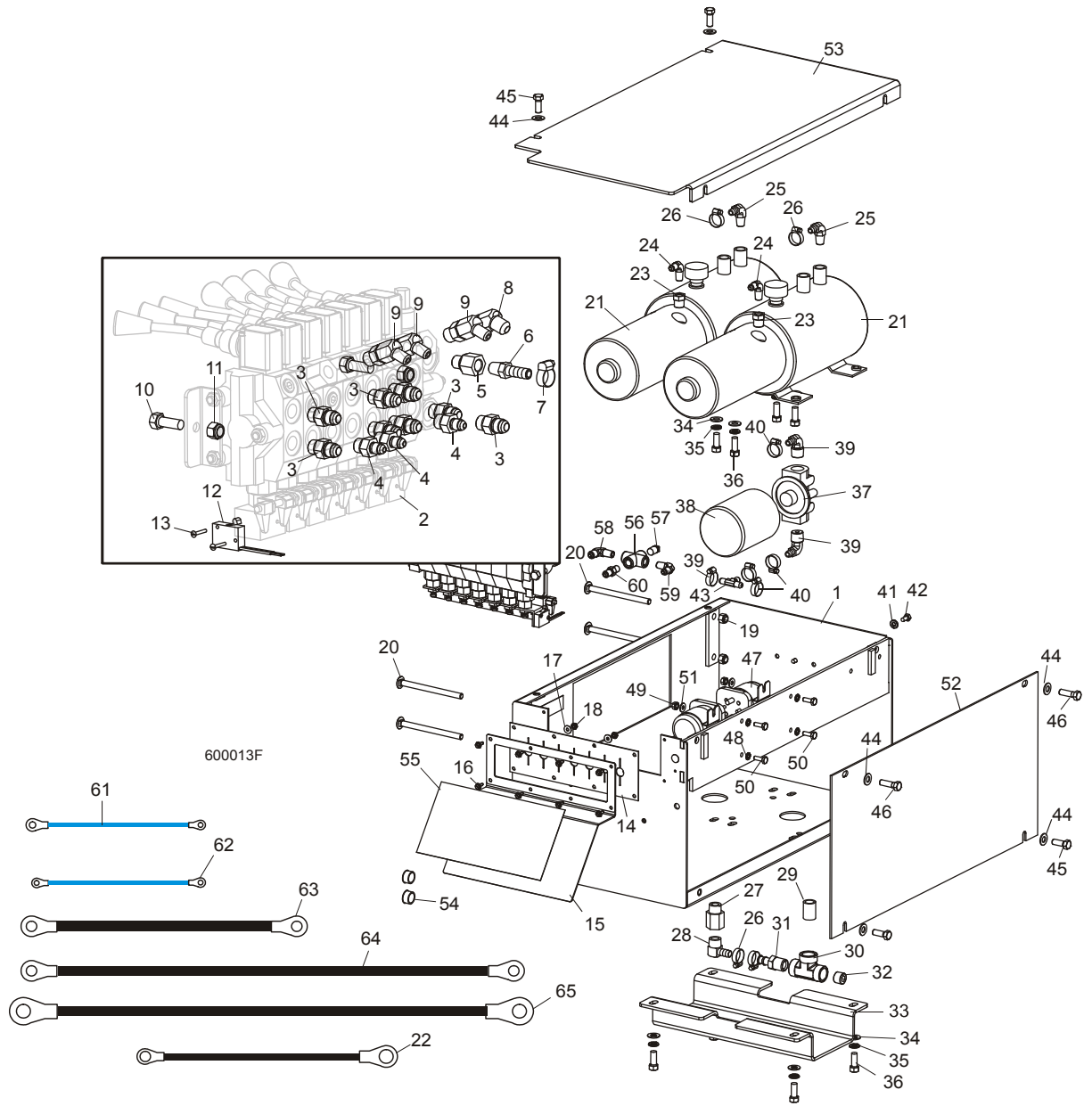

REF	DESCRIPTION (◆ Indicates Parts Available In Assemblies Only)	PART #	QTY.
	<b>BOX ASSEMBLY, HYDRAULIC CONTROL</b>	017649	1
1	Box Weldment, Hydraulic Control	034383	1
	Valve Assembly, 7-Section Hydraulic	034533	1
2	Valve, 7-Section Hydraulic	034451	1
3	Fitting, 3/8" O-Ring x 3/8" JIC	014687	8
4	Fitting, 1/4" JIC x 3/8" O-Ring	P26284	3

5	Fitting, #6 SAE x 1/4" NPT Female	014686	1	
6	Fitting, 1/4" NPT x 3/8" Hose Barb	014685	1	
7	Clamp, 11/16" Hose	P12739	1	
8	Fitting, #6 SAE 45° Elbow	015489	1	
9	Fitting, #4 SAE x #6 SAE 45° Elbow	015488	3	
10	Bolt, 3/8-16 x 1" Hex Head	F05007-7	2	
11	Nut, 3/8-16 Hex Nylon Lock	F05010-10	2	
12	Switch, Hydraulic Valve Lever	024198	1	
13	Screw, #4-40 x 3/4" Slotted Head	F05004-13	2	
14	Seal, 7-Handle Valve Rubber	034202	1	
15	Plate, 7-Handle Decal	033999	1	
16	Screw, #10-24 x 1/2" Self-Tapping	F05015-7	8	
17	Washer, #10 SAE Flat	F05011-18	2	
18	Nut, #10-24 Hex Self-Locking	F05010-14	2	
19	Nut, 3/8-16 Hex Nylon Lock	F05010-10	4	
20	Bolt, 3/8-16 x 5" Carriage Head	F05007-113	4	
	Pump Assembly, LT60/70 DC Hydraulic	034534	1	
21	Pump Kit, Hydraulic w/Motor	061764 <sup>1</sup>	2	
	Pump, Hydraulic Replacement Monarch Model #12070	016199	1	
	Motor Kit, Hydraulic Replacement	052807	1	
	Motor, 12 VDC Hydraulic Pump #08714 (Iskra)	038683	1	◆
	Brush Kit, 4-Valve Hydraulic Pump Motor #08658-I (Iskra)	038682	1	
	Bearing, Base Motor #02318	P12513	1	
22	Wire Assembly, Motor Brush Ground	052806	1	
	Cap, Hydraulic Pump Vented Fill #03171	P12817	1	
	O-Ring, Hydraulic Pump/Reservoir #02352	P10198	1	
	Seal, Hydraulic Pump/Motor #02330	P10315	1	
23	Fitting, 3/8" NPT x 1/4" NPT Reducer	015490	2	
24	Fitting, 1/4" NPT x 1/4" JIC Elbow	P09142	2	
25	Fitting, 3/8" NPT x 3/8" Hose Barb Elbow	P12708	2	
26	Clamp, 11/16" Hose	P12739	4	
27	Fitting, 1/2" NPT x 1/2" NPT Adapter	015995	1	
28	Fitting, 1/2" NPT x 1/2" Hose Barb Elbow	015997	1	
29	Fitting, 1/2" NPT Close Brass Nipple	016795	1	
30	Fitting, 1/2" NPT Female Tee	016793	1	
31	Fitting, 1/2" NPT Male x 1/2" Hose Barb	016794	1	
32	Fitting, 1/2" NPT Pipe Plug	P26258	1	
33	Guard, Crossover Hose	015992	1	
34	Washer, 3/8" SAE Flat	F05011-3	8	
35	Washer, 3/8" Split Lock	F05011-4	8	
36	Bolt, 3/8-16 x 1" Hex Head	F05007-7	8	
37	Manifold, Hydraulic Filter w/Cartridge	P22683	1	
38	Filter, S28 Hydraulic Cartridge	P20301	1	

# 10

## Hydraulic System Hydraulic Control Box

39	Fitting, 1/2" NPT x 3/8" Hose Barb Elbow	P12707	2	
40	Clamp, 11/16" Hose Clamp	P12739	2	
41	Washer, 1/4" Split Lock	F05011-14	2	
42	Bolt, 1/4-20 x 1/2" Hex Head	F05005-15	2	
43	Fitting, 3/8" Hose Barb Tee	015485	1	
44	Washer, 3/8" SAE Flat	F05011-3	6	
45	Bolt, 3/8-16 x 1" Hex Head Grade 5	F05007-87	4	
46	Bolt, 3/8-16 x 1 1/4" Hex Head	F05007-2	2	
47	Solenoid Kit, 200A 12V SPST Hydraulic Motor	016371	2	
	Solenoid, 200A 12V SPST Cont. Duty	015470	1	◆
	Diode Assembly, Solenoid Coil Chassis Gnd	015426	1	
48	Washer, 1/4" External Lock	F05011-37	4	
49	Nut, 1/4-20 Hex Self-Locking	F05010-9	4	
50	Bolt, 1/4-20 x 3/4" Hex Head Full Thread	F05005-1	4	
51	Washer, 1/4" SAE Flat	F05011-11	4	
52	Plate, Hydraulic Control Box Side	015227	1	
53	Plate, Hydraulic Control Box Top	015228	1	
54	Grommet, 5/8" Wire	P04137	2	
55	Decal, Hydraulic Control Lever	017669	1	
56	Fitting, 1/4" NPT Cross	P22311	1	
57	Gauge, 5000 PSI Hydraulic Pressure	P10052	1	
58	Fitting, 3/8" JIC x 1/4" NPT Elbow	015490	1	
59	Fitting, 1/4" NPT x 1/4" JIC Male Elbow	P09142	1	
60	Fitting, 1/4" NPT x 1/4" JIC Male	P09143	1	
	Hose, 3/8" x 6 1/2" Hydraulic w/Fittings	036303	1	
	Hose, 1/4" x 15" Hydraulic w/Fittings	036292	2	
61	<b>WIRE ASSEMBLY, 14 GA X 4" #10 &amp; 5/16" RING TERMINALS</b>	036315	2	
62	<b>WIRE ASSEMBLY, 14 GA X 4" #10 RING TERMINALS</b>	036314	1	
63	<b>CABLE ASSEMBLY, 1 GA X 6" HYDRAULIC PUMP TO SOLENOID</b>	036311	1	
64	<b>CABLE ASSEMBLY, 1 GA X 16" HYDRAULIC PUMP TO SOLENOID</b>	036310	1	
65	<b>CABLE ASSEMBLY, 1 GA X 16" HYDRAULIC PUMP GROUND</b>	036312	2	
	<b>WASHER, 3/8" STAR EXTERNAL</b>	F05011-36	3	

<sup>1</sup> Pump Kit 061764 replaces Pump P12701 1/09. Kit includes P12701 plus Brush Ground Wire Kit 052805 to insure adequate ground connection.

## 10.4 Hydraulic Power Supply Strip

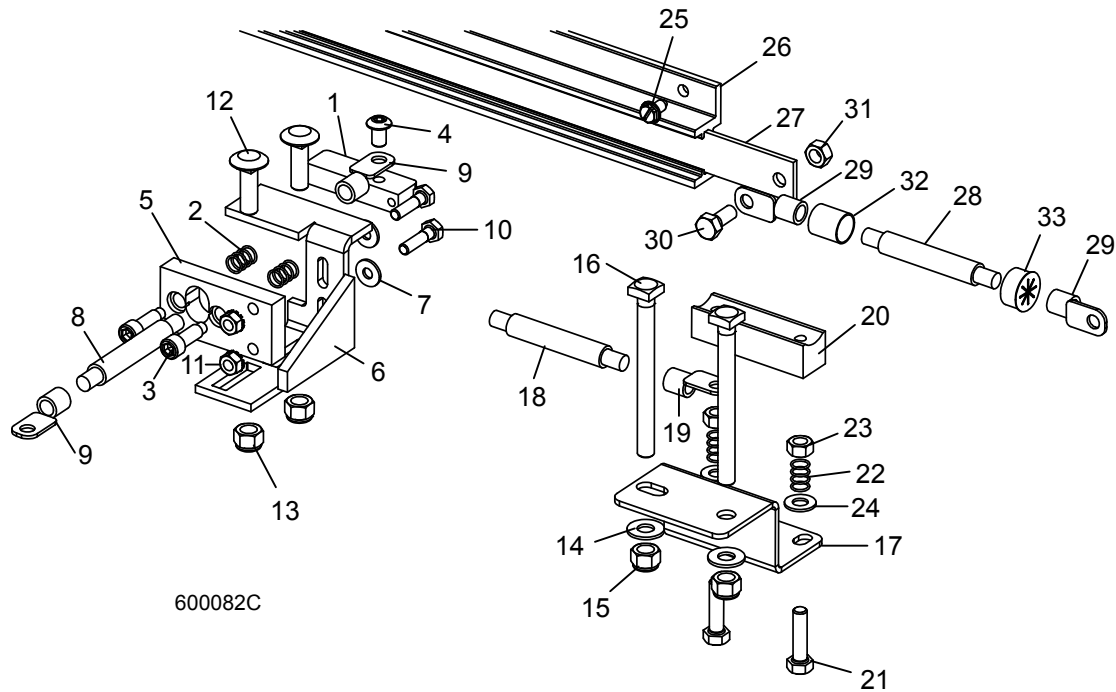

600082C

REF	DESCRIPTION (◆ Indicates Parts Available In Assemblies Only)	PART #	QTY.	
	<b>CONTACT ASSEMBLY, HYDRAULIC POWER SUPPLY (POSITIVE)</b>	010103	1	
	Contact Kit, 97+ Hydraulic Power Supply Positive	007716	1	
1	Contact, Hydraulic Power Supply (Positive)	015253	1	
2	Spring, Positive Contact	P10077	2	
3	Bolt, 5/16" X 3/4" Shoulder (1/4-20 Thread) Stainless	F05006-143 <sup>1</sup>	2	
4	Bolt, 5/16-18 x 1/2" Socket Button Head	F05006-20	1	
5	Insulator, Positive Contact	S10072	1	
6	Bracket, Positive Contact Mounting	015324	1	
7	Washer, 1/4" SAE Flat	F05011-11	2	
8	Cable, #1 Weld	R01971 <sup>2</sup>	1.17 Ft	◆
9	Terminal, 5/16" Ring #2 Gauge	F05092-16 <sup>2</sup>	2	
10	Bolt, 1/4-20 X 1" Hex Head Grade 2	F05005-38	2	
11	Nut, 1/4-20 Hex Self-Locking	F05010-9	2	
12	Bolt, 3/8-16 X 1 1/4" Carriage Head	F05007-11	2	
13	Nut, 3/8-16 Hex Nylon Lock	F05010-10	2	
	<b>CONTACT KIT, HYDRAULIC POWER SUPPLY (GROUND)</b>	010104	1	
14	Washer, 3/8" SAE Flat	F05011-3	2	
15	Nut, 3/8-16 Hex Nylon Lock	F05010-10	2	
16	Bolt, 3/8-16 X 4" Square Head	F05007-175	2	
17	Bracket, Ground Contact Mounting	016792	1	

# 10

## Hydraulic System

### Hydraulic Power Supply Strip

18	Cable Assy, Hydraulic Negative Contact (Ground) #1 Weld	036306	1	
	Cable, #1 Weld	R01971	2.2 Ft	◆
19	Terminal, 5/16" Ring #2 Gauge	F05092-16	2	
	Contact Kit, Hydraulic Power Supply Ground	007717	1	
20	Contact, Hydraulic Power Supply (Ground)	015264	1	
21	Bolt, 5/16-18 X 1 1/4" Hex Head Full Thread Grade 5	F05006-93	2	
22	Spring, Ground Contact	P10077	2	
23	Nut, 5/16-18 Hex	F05010-17	2	
24	Washer, 5/16" SAE Flat	F05011-17	2	
	<b>STRIP ASSEMBLY, 6' HYDRAULIC POWER SUPPLY W/2 3FT. CABLES</b>	015564	1	
25	Screw, 1/4-20 X 1/2" Slotted Hex Head	F05015-1	8	
26	Housing, 6' Contact Strip	P11976	1	
	Strip, 6' Contact With 2Cables	015886	1	
27	Strip, 6' Contact	S10075	1	◆
28	Cable Assembly, Hydraulic Contact Strip	052161	2	
	Cable, #1 Weld	R01971	3 Ft	◆
29	Terminal, 5/16" Ring #2 Gauge	F05092-16	2	
30	Bolt, 5/16-18 X 3/4" Hex Head Black Nylon	F05006-45	1	
31	Nut, 5/16-18 Hex Black Nylon	F05010-86	1	
32	Tube, 5/8" Heat Shrink	R01950-5	.33 Ft	◆
33	Grommet, 5/8" Wire	P04137	1	

<sup>1</sup> Stainless Steel Bolt F05006-143 replaces F05006-44 to prevent corrosion (Rev. A5.02).

<sup>2</sup> See [Section 5.9](#) for pre-assembled cable service assemblies.



### 10.5 Hydraulic Log Loader

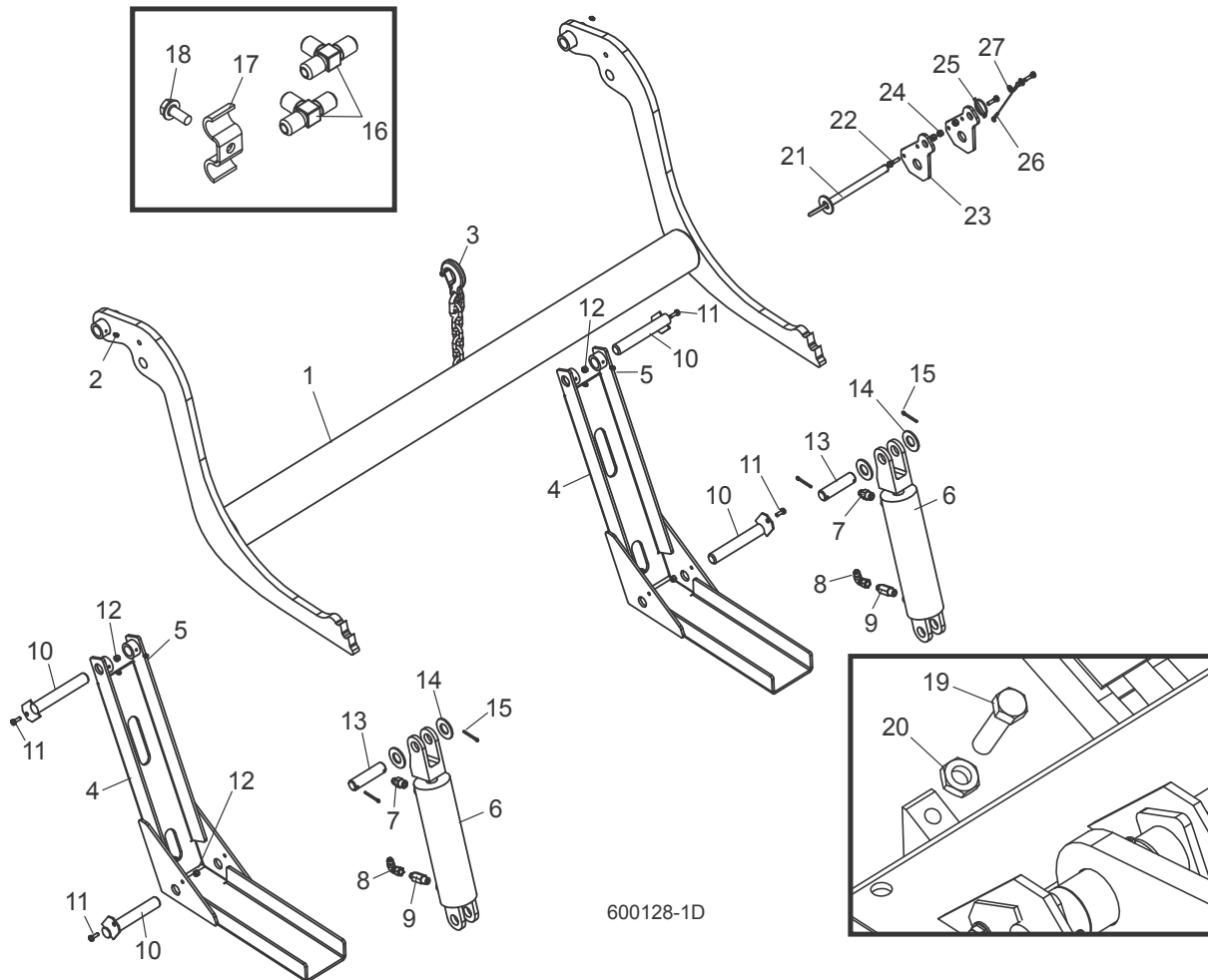

600128-1D

REF	DESCRIPTION (◆ Indicates Parts Available In Assemblies Only)	PART #	QTY.
	<b>LOADER ASSEMBLY, HYDRAULIC LOG</b>	034539	1
1	Arm, Hydraulic Log Loading	036416	1
2	Fitting, 3/16" Grease	P04107	2
3	Chain, Hydraulic Log Loader Safety	A04376	1
4	Channel, Hydraulic Log Loading Foot	W09444	2
5	Fitting, 3/16" Grease	P04107	4
6	Cylinder Assembly, Hydraulic Log Loader	038735	2
	Seal Kit, 8" x 3" Hydraulic Cylinder	P12956	1
7	Fitting, 3/8" NPT x 3/8" JIC Male Connector	016819	1
8	Fitting, 3/8" JIC 90° Swivel Elbow	042756	1

# 10

## Hydraulic System

### Hydraulic Log Loader

9	Fitting, 3/8NPT 6.5GPM Velocity Fuse	038734	1	
10	Pin, Loading Arm Mount	W09446	4	
11	Bolt, 1/4-20 x 3/4" Hex Head Full Thread	F05005-1	4	
12	Nut, 1/4-20 Hex Lock	F05010-69	4	
13	Pin, Loading Arm Cylinder Mount	S09251	2	
14	Washer, 1" SAE Flat	F05011-28	4	
15	Pin, 3/16" X 1 1/2" Cotter	F05012-23	4	
16	Fitting, 3/8" JIC Union 'T'	015487	1	
17	Clamp, 3/8" Hydraulic Hose	016041	6	
18	Bolt, 5/16-18 X 3/4" Hex Head Grade 5	F05006-102 <sup>1</sup>	6	
19	<b>BOLT, 1/2-13 X 3" HEX HEAD FULL THREAD GRADE 5</b>	F05008-7	2	
20	<b>NUT, 1/2-13 JAM</b>	F05010-31	2	

<sup>1</sup> Grade 5 Hex Head Bolt F05006-102 replaces self-tapping bolt F05006-30 to eliminate shearing of bolts head (4/08).

## 10.6 Hydraulic Log Turner

LT50HD

Rev. A4.00 - A5.02

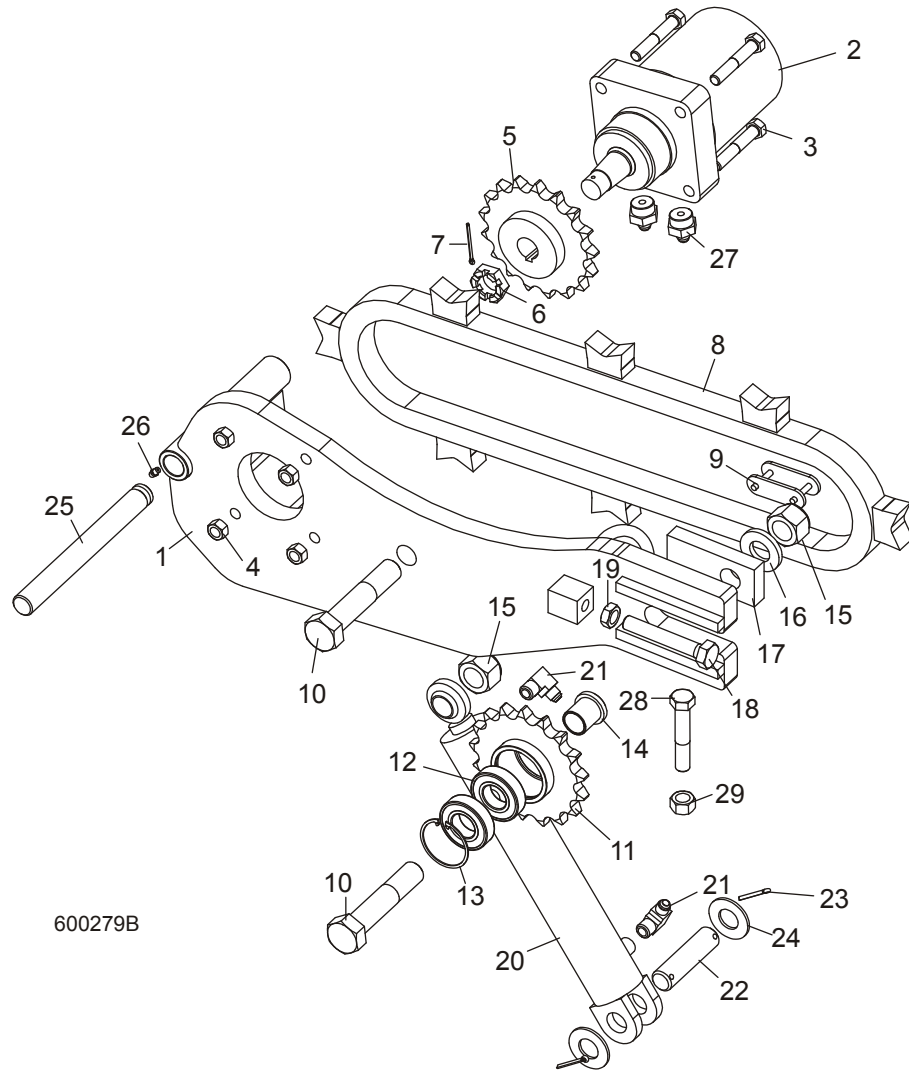

600279B

REF	DESCRIPTION (◆ Indicates Parts Available In Assemblies Only)	PART #	QTY.
	<b>ARM ASSEMBLY, HYDRAULIC LOG TURNER</b>	006095	1
1	Arm Weldment, Hydraulic Log Turner	006471	1
2	Motor, Hydraulic Log Turner	007331 <sup>1</sup>	1
3	Bolt, 1/2-13 x 3" Hex Head Grade 5	F05008-23	4
4	Nut, 1/2-13 Hex Lock	F05010-3	4
5	Sprocket Weldment, Log Turner Drive	042192	1
6	Nut, Hydraulic Motor Castle	018741-2	1
7	Pin, 1/8" x 1 3/4" Cotter	F05012-43	1
8	Chain Weldment, Log Turner	006097	1

# 10

## Hydraulic System Hydraulic Log Turner

9	Link, #2080H Master	016796	1	
10	Bolt, 1-8 x 5" Hex Head Grade 8	F05004-132	2	
	Sprocket Assembly, Idler	042193	1	
11	Sprocket Weldment, Idler	042191	1	
12	Bearing, 6206 25 Idler	P11035	2	
13	Ring, 62mm #472 DIN Inside Retaining	F04254-12	1	
14	Spacer, Idler Sprocket	042187	2	
15	Nut, 1-8 Hex Lock	F05010-109	2	
16	Washer, 1" ID x 2" OD x 1/4"	038749	1	
17	Plate, Log Turner Chain Tensioner	042188	1	
18	Bolt, 5/8-11 x 4" Hex Head Full Thread Grade 5	F05009-31	1	
19	Nut, 5/8-11 Hex Jam	F05010-82	1	
20	Cylinder, 2" x 10" Welded Rod End Hydraulic	034267	1	
	Seal Kit, 2x10 Hydraulic Cylinder	003814	1	
21	Fitting, 3/8" NPT x 3/8" JIC 90° Elbow	016820	2	
22	Pin, 1" x 3.88"	S09251	1	
23	Pin, 3/16" x 1 1/2" Cotter	F05012-23	2	
24	Washer, 1" SAE Flat	F05011-28	2	
25	Rod, Grooved Turner Mount	006722	1	
26	Fitting, 1/4-28 Grease	P05060	1	
27	Fitting, #10 SAE x 3/8" JIC Straight	017640	2	
28	<b>BOLT, 5/8-18 X 3 1/2" HEX HEAD BOLT FULL THREAD</b>	F05009-16	1	
29	<b>NUT, 5/8-18 HEX</b>	F05010-50	1	

<sup>1</sup> Hydraulic Motor 007331 replaces 018741 originally supplied prior to 6/09. 018741 was changed by the vendor and no longer fits the hole in the log turner arm.

## 10.7 Hydraulic Log Turner

LT50HD

Rev. A1.01 - A3.00

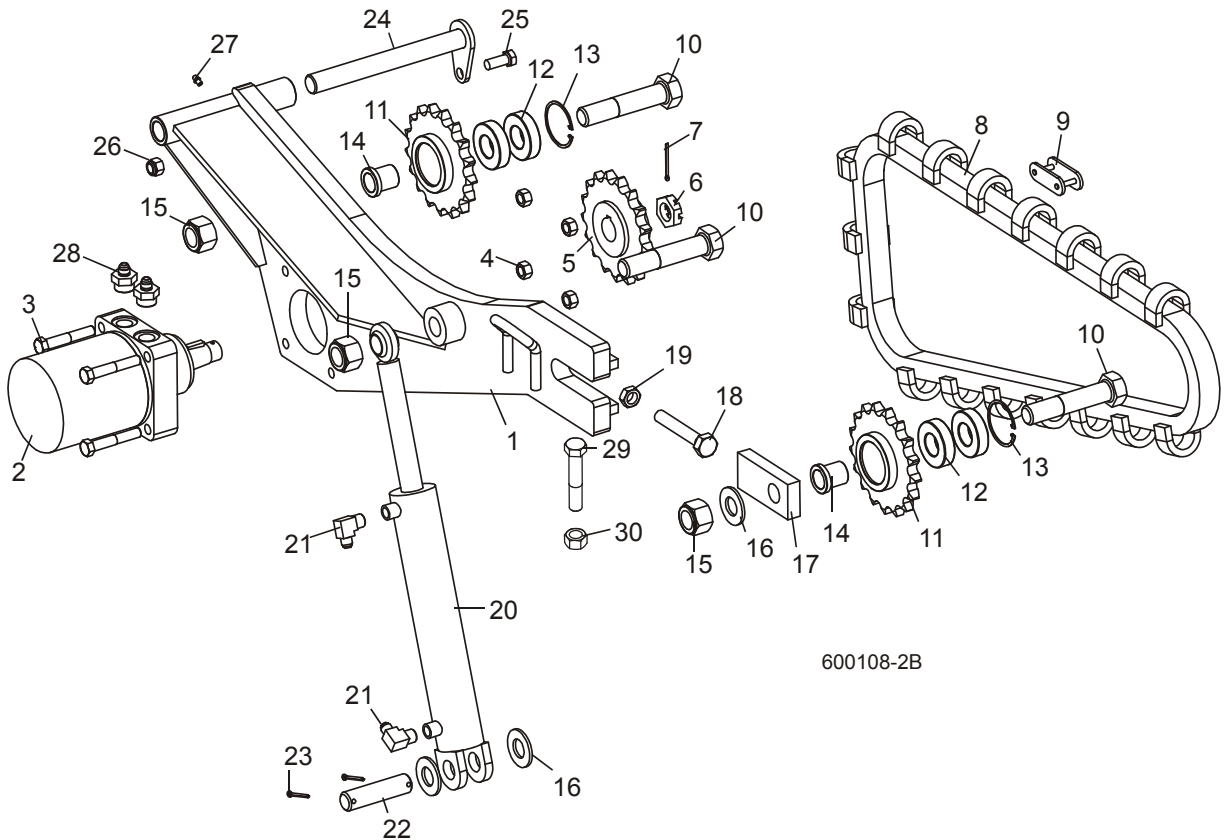

REF	DESCRIPTION (◆ Indicates Parts Available In Assemblies Only)	PART #	QTY.
	<b>ARM ASSEMBLY, HYDRAULIC LOG TURNER</b>	034537	1
1	Arm Weldment, Hydraulic Log Turner	016873	1
2	Motor, Hydraulic Log Turner	007331 <sup>1</sup>	1
3	Bolt, 1/2-13 x 3" Hex Head Grade 5	F05008-23	4
4	Nut, 1/2-13 Hex Lock	F05010-3	4
5	Sprocket Weldment, Log Turner Drive	042192	1
6	Nut, Hydraulic Motor Castle	018741-2	1
7	Pin, 1/8" x 1 3/4" Cotter	F05012-43	1
8	Chain Weldment, Log Turner	025655 <sup>2</sup>	1
	Cog, Log Turner	042194 <sup>3</sup>	17
	Chain, #2080 Log Turner	042195	1
9	Link, #2080H Master	016796	1
10	Bolt, 1-8 x 5" Hex Head Grade 8	F05004-132	3
	Sprocket Assembly, Idler	042193	2
11	Sprocket Weldment, Idler	042191	1

# 10

## Hydraulic System Hydraulic Log Turner

12	Bearing, 6206 25 Idler	P11035	2	
13	Ring, 62mm #472 DIN Inside Retaining	F04254-12	1	
14	Spacer, Idler Sprocket	042187	2	
15	Nut, 1-8 Hex Lock	F05010-109	3	
16	Washer, 1" SAE Flat	F05011-28	3	
17	Plate, Log Turner Chain Tensioner	042188	1	
18	Bolt, 5/8-11 x 4" Hex Head Full Thread Grade 5	F05009-31	1	
19	Nut, 5/8-11 Hex Jam	F05010-82	1	
20	Cylinder, 2" x 10" Welded Rod End Hydraulic	034267	1	
	Seal Kit, 2x10 Hydraulic Cylinder	003814	1	
21	Fitting, 3/8" NPT x 3/8" JIC 90° Elbow	016820	2	
22	Pin, 1" x 3.88"	S09251	1	
23	Pin, 3/16" x 1 1/2" Cotter	F05012-23	2	
24	Pin Weldment, Log Turner Mount	042331	1	
25	Bolt, 1/2-13 x 1 1/4" Hex Head Grade 5	F05008-37	1	
26	Nut, 1/2-13 Hex Nylon Lock	F05010-8	1	
27	Fitting, 1/4-28 Grease	P05060	1	
28	<b>FITTING, #10 SAE X 3/8" JIC STRAIGHT</b>	017640	2	
29	<b>BOLT, 5/8-18 X 3 1/2" HEX HEAD BOLT FULL THREAD</b>	F05009-16	1	
30	<b>NUT, 5/8-18 HEX</b>	F05010-50	1	

<sup>1</sup> Hydraulic Motor 007331 replaces 018741 originally supplied prior to 6/09. 018741 was changed by the vendor and no longer fits the hole in the log turner arm.

<sup>2</sup> Turner Chain 025655 replaces original chain 042196 supplied prior to 4/10. New chain provides more aggressive log turning.

<sup>3</sup> Applies to original Turner Chain 042196 only.

### 10.8 Hydraulic Log Side Supports (Front)

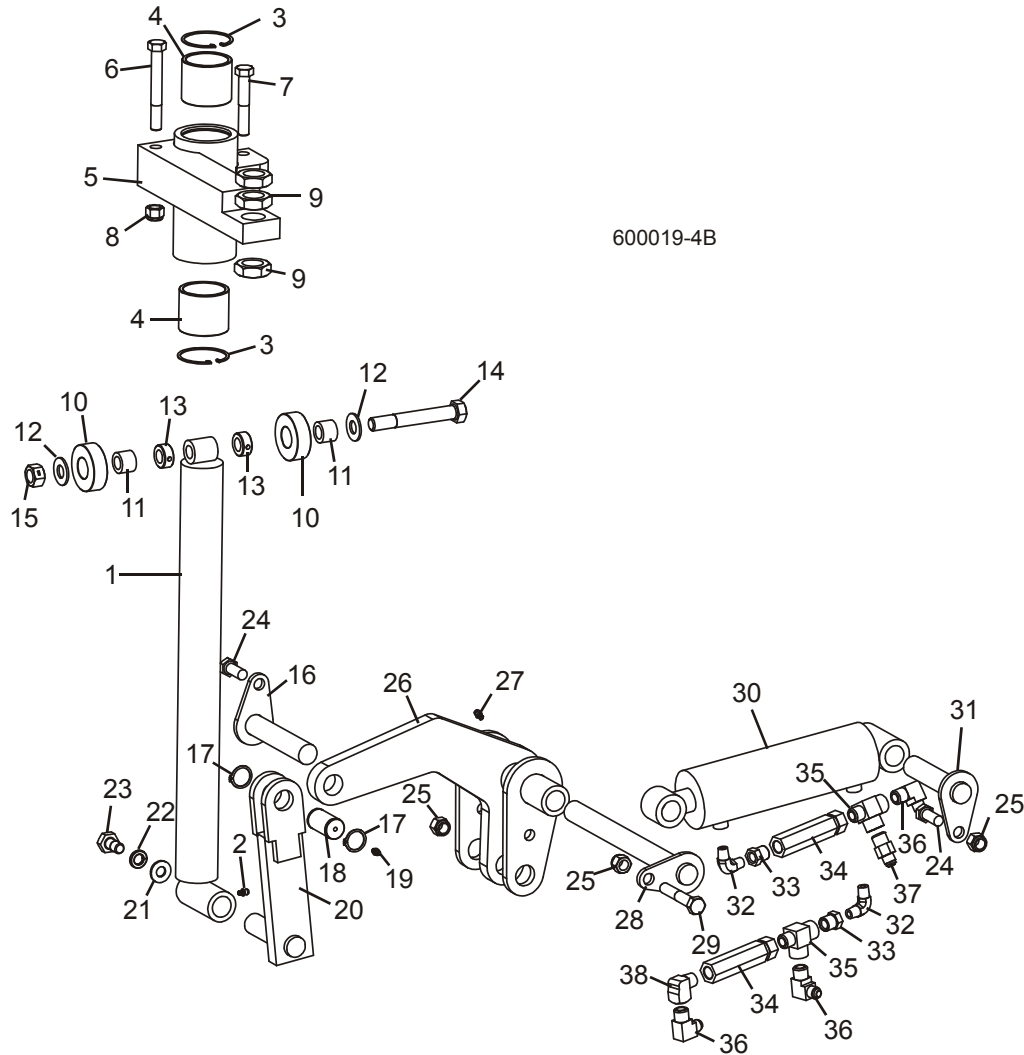

REF	DESCRIPTION (◆ Indicates Parts Available In Assemblies Only)	PART #	QTY.
	<b>SUPPORT ASSEMBLY, VERTICAL HYDRAULIC SIDE</b>	034732	1
1	Rod Weldment, Vertical Side Support	034704	1
2	Fitting, 3/16" Straight Grease	P04107	1
3	Ring, 62mm Din #472 Inside Retaining	F04254-12	2
4	Bushing, Side Support	042262	2
5	Mount Weldment, Vertical Side Support	034703	1
6	Bolt, 1/2-13 x 4" Hex Head Grade 5	F05008-78	1
7	Bolt, 1/2-13 x 3" Hex Head Grade 5	F05008-23	1
8	Nut, 1/2-13 Hex Nylon Lock	F05010-8	2
9	Nut, 1-14 Hex Jam	F05010-118	3
	Roller Kit, Side Support	034733	1

# 10

## Hydraulic System

### Hydraulic Log Side Supports (Front)

10	Roller, Side Support	016561	2	
11	Bushing, 5/8" x 1" x 3/4" Bronze	016560	2	
12	Washer, 5/8" SAE Flat	F05011-5	2	
13	Collar, 5/8" Lock	P05035	2	
14	Bolt, 5/8-11 x 4 1/2" Hex Head Grade 5	F05009-10	1	
15	Nut, 5/8-11 Hex Lock	F05010-4	1	
16	<b>PIN WELDMENT, 5 1/4" PIVOT</b>	034727	1	
	<b>PIN ASSEMBLY, SIDE SUPPORT PIVOT</b>	036053	1	
17	Pin, Grooved Pivot	034718	1	◆
18	Ring, 1" 3100-100 Outside Retaining	F04254-15	2	
19	Fitting, 3/16" Straight Grease	P04107	1	
20	<b>PUSHER WELDMENT, LOWER SIDE SUPPORT</b>	034711	1	
21	<b>WASHER, 9/16" SAE FLAT</b>	F05011-52	1	
22	<b>WASHER, 1/2" SPLIT LOCK</b>	F05011-9	1	
23	<b>BOLT, 1/2-13 X 1" HEX HEAD</b>	F05008-50	1	
24	<b>BOLT, 1/2"-13 X 1 1/4" HEX HEAD GRADE 5</b>	F05008-37	2	
25	<b>NUT, 1/2-13 HEX NYLON LOCK</b>	F05010-8	3	
26	<b>ARM WELDMENT, VERTICAL SIDE SUPPORT FRONT LIFT</b>	034715	1	
27	<b>FITTING, 3/16" STRAIGHT GREASE</b>	P04107	1	
28	<b>PIN WELDMENT, 10 7/8" PIVOT</b>	034728	1	
29	<b>BOLT, 1/2-13 X 3" HEX HEAD GRADE 5</b>	F05008-23	1	
30	<b>CYLINDER, 2 1/2" X 6" X 1/4" NPT PORT HYDRAULIC</b>	034736	1	
31	<b>PIN WELDMENT, 4 3/8" PIVOT</b>	034726	1	
32	<b>FITTING, 1/4" NPT MALE PIPE ELBOW</b>	P09140	2	
33	<b>FITTING, 3/8" NPT X 1/4" NPT REDUCER</b>	015490	2	
34	<b>VALVE, SIDE SUPPORT SEQUENCE</b>	015484	2	
35	<b>FITTING, 3/8" NPT MALE RUN TEE</b>	016822	2	
36	<b>FITTING, 3/8" NPT X 3/8" JIC ELBOW</b>	016820	3	
37	<b>FITTING, 3/8" NPT X 3/8" JIC CONNECTOR</b>	016819	1	
38	<b>FITTING, 3/8" NPT STREET ELBOW</b>	P05759	1	



## 10.9 Hydraulic Log Side Supports (Rear)

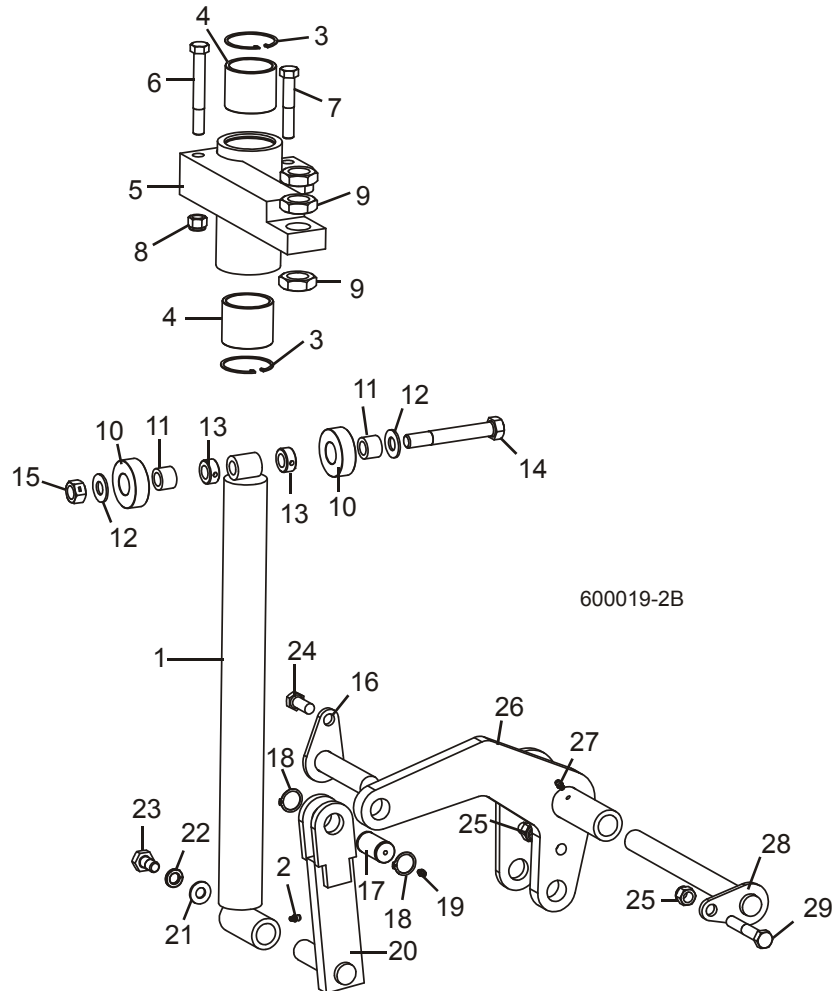

REF	DESCRIPTION (◆ Indicates Parts Available In Assemblies Only)	PART #	QTY.
	<b>SUPPORT ASSEMBLY, VERTICAL HYDRAULIC SIDE</b>	034732	1
1	Rod Weldment, Vertical Side Support	034704	1
2	Fitting, 3/16" Straight Grease	P04107	1
3	Ring, 62mm Din #472 Inside Retaining	F04254-12	2
4	Bushing, Side Support	042262	2
5	Mount Weldment, Vertical Side Support	034703	1
6	Bolt, 1/2-13 x 4" Hex Head Grade 5	F05008-78	1
7	Bolt, 1/2-13 x 3" Hex Head Grade 5	F05008-23	1
8	Nut, 1/2-13 Hex Nylon Lock	F05010-8	2
9	Nut, 1-14 Hex Jam	F05010-118	3
	Roller Kit, Side Support	034733	1
10	Roller, Side Support	016561	2
11	Bushing, 5/8" x 1" x 3/4" Bronze	016560	2

# 10

## Hydraulic System

### Hydraulic Log Side Supports (Rear)

12	Washer, 5/8" SAE Flat	F05011-5	2	
13	Collar, 5/8" Lock	P05035	2	
14	Bolt, 5/8-11 x 4 1/2" Hex Head Grade 5	F05009-10	1	
15	Nut, 5/8-11 Hex Lock	F05010-4	1	
16	<b>PIN WELDMENT, 4 3/8" PIVOT</b>	034726	1	
	<b>PIN ASSEMBLY, SIDE SUPPORT PIVOT</b>	036053	1	
17	Pin, Grooved Pivot	034718	1	◆
18	Ring, 1" 3100-100 Outside Retaining	F04254-15	2	
19	Fitting, 3/16" Straight Grease	P04107	1	
20	<b>PUSHER WELDMENT, LOWER SIDE SUPPORT</b>	034711	1	
21	<b>WASHER, 9/16" SAE FLAT</b>	F05011-52	1	
22	<b>WASHER, 1/2" SPLIT LOCK</b>	F05011-9	1	
23	<b>BOLT, 1/2-13 X 1" HEX HEAD</b>	F05008-50	1	
24	<b>BOLT, 1/2"-13 X 1 1/4" HEX HEAD GRADE 5</b>	F05008-37	2	
25	<b>NUT, 1/2-13 HEX NYLON LOCK</b>	F05010-8	2	
26	<b>ARM WELDMENT, VERTICAL SIDE SUPPORT REAR LIFT</b>	034716	1	
27	<b>FITTING, 3/16" STRAIGHT GREASE</b>	P04107	1	
28	<b>PIN WELDMENT, 10 7/8" PIVOT</b>	034728	1	
29	<b>BOLT, 1/2-13 X 3" HEX HEAD GRADE 5</b>	F05008-23	1	

### 10.10 Hydraulic Log Side Supports (Link)

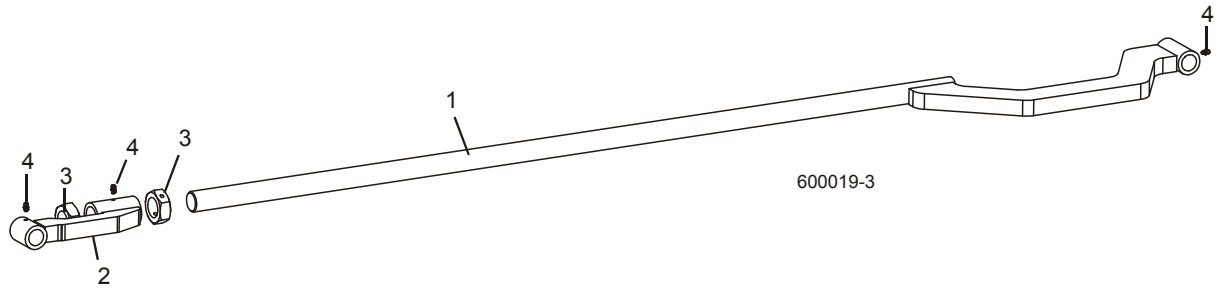

REF	DESCRIPTION (◆ Indicates Parts Available In Assemblies Only)	PART #	QTY.	
1	ROD WELDMENT, SIDE SUPPORT LINK	034725	1	
2	ARM WELDMENT, SIDE SUPPORT LINK	034724	1	
3	NUT, 1 1/4"-12 HEX JAM	F05010-100	2	
4	FITTING, 3/16" STRAIGHT GREASE	P04107	3	

10.11 Hydraulic Log Clamp

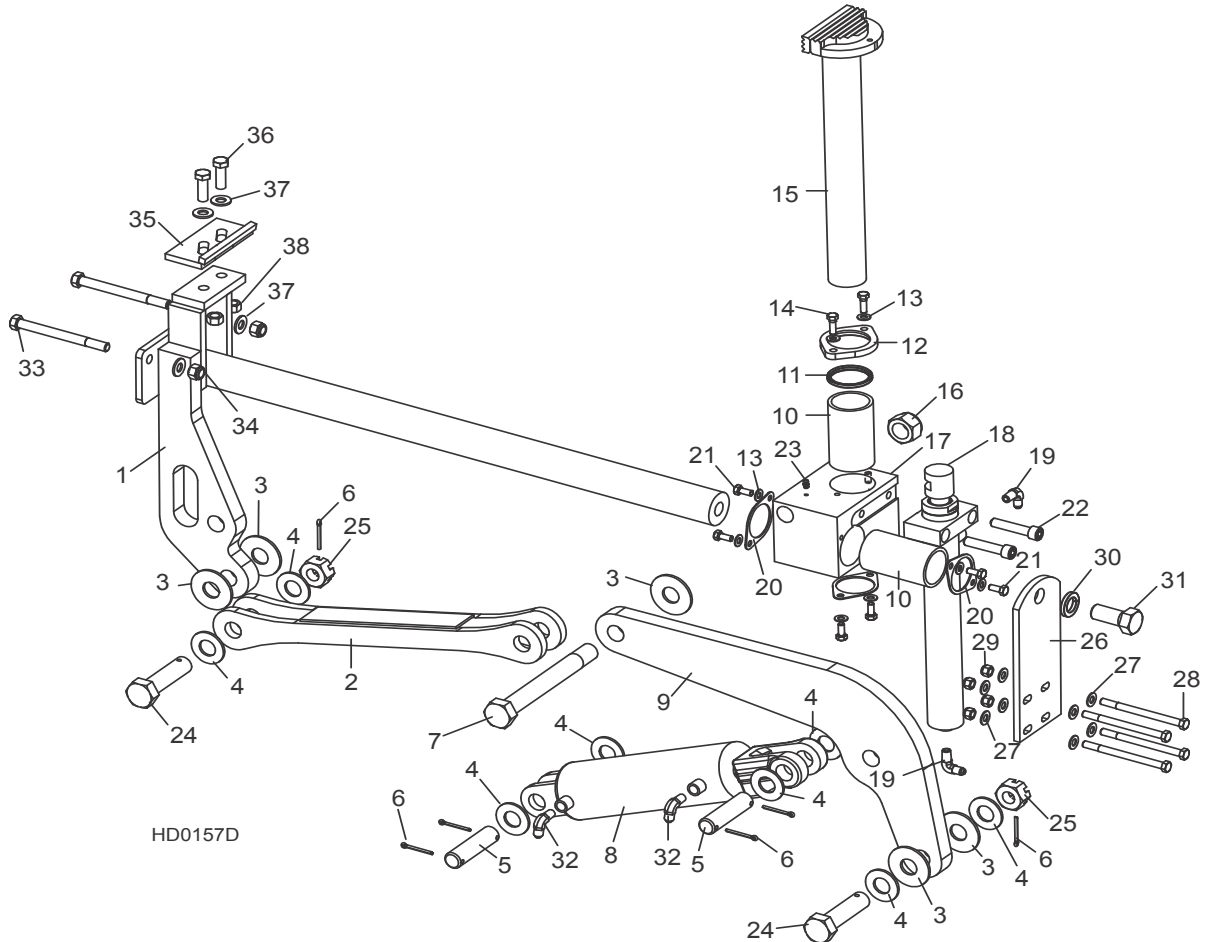

REF	DESCRIPTION (◆ Indicates Parts Available In Assemblies Only)	PART #	QTY.
	<b>CLAMP ASSEMBLY, HYDRAULIC 2-PLANE</b>	017264	1
1	Mount Weldment, Hydraulic Clamp Slide	017265	1
2	Link Weldment, Hydraulic Clamp	017267	1
3	Washer, 1/8" x 2 1/2" Hardened	015057	5
4	Washer, 1" SAE Flat	F05011-28	8
5	Pin, 1" x 3.88"	S09251	2
6	Pin, 3/16" x 1 1/2" Cotter	F05012-23	6
7	Bolt, 1-14 x 8 1/2" Hex Head Grade 8	015049	1
8	Cylinder, 3" x 7" Hydraulic	017275	1
	Seal Kit, Hydraulic Cylinder	P12956	1
9	Arm, Clamp Pivot	017274	1
10	Bushing, Clamp Slide	015088	2
	Wiper Assembly, Vertical Clamp Rod	017271	1
11	Wiper, Vertical Clamp Rod	017273	1

12	Flange, Vertical Clamp Rod Wiper	017272	1	
13	Washer, 5/16" SAE Flat	F05011-17	8	
14	Bolt, 5/16-18 x 1" Hex Head	F05006-1	2	
15	Clamp Weldment, Vertical	015043	1	
16	Nut, 1-14 Hex Jam	F05010-118	2	
17	Block, Hydraulic Clamp Slide	017270	1	
18	Cylinder Weldment, Vertical Clamp Hydraulic	015050	1	
	Seal Kit, Hydraulic Cylinder	016204	1	
	Instruction Sheet, Vertical Clamp Seal Replacement	016204-1009	1	
19	Fitting, 1/4" NPT x 1/4" JIC Elbow	P09142	2	
20	Retainer, Clamp Bushing	017242	3	
21	Bolt, 5/16-18 x 3/4" Hex Head	F05006-5	6	
22	Bolt, 1/2-13 x 2 1/2" Socket Head	F05008-39	2	
23	Fitting, 3/16" Straight Grease	P04107	1	
24	Bolt, 1-14 x 3 3/4" Hex Head Grade 8 w/Hole	015072	2	
25	Nut, 1-14 Slotted Hex	F05010-163	2	
26	Plate, Log Clamp Mount	015068	1	
27	Washer, 3/8" SAE Flat	F05011-3	8	
28	Bolt, 3/8-16 x 5" Hex Head	F05007-5	4	
29	Nut, 3/8-16 Hex Nylon Lock	F05010-10	4	
30	Washer, 7/8" Split Lock	F05011-46	1	
31	Bolt, 7/8-14 x 2" Hex Head Grade 5	F05014-2	1	
32	Fitting, 1/4" NPT - 3/8" JIC Elbow	015491	2	
33	Bolt, 1/2-13 x 5 1/2" Hex Head Grade 5	F05008-28	2	
34	Nut, 1/2-13 Hex Nylon Lock	F05010-8	2	
	Clamp Stop Kit, Hydraulic Log	K09485	1	
35	Plate, Clamp Stop	W09404	1	
36	Bolt, 1/2-13 X 1 1/2" Hex Head Grade 5	F05008-33	2	
37	Washer, 1/2" SAE Flat	F05011-2	2	
38	Nut, 1/2-13 Hex Lock	F05010-3	2	

**10.12 Hydraulic Toe Board**

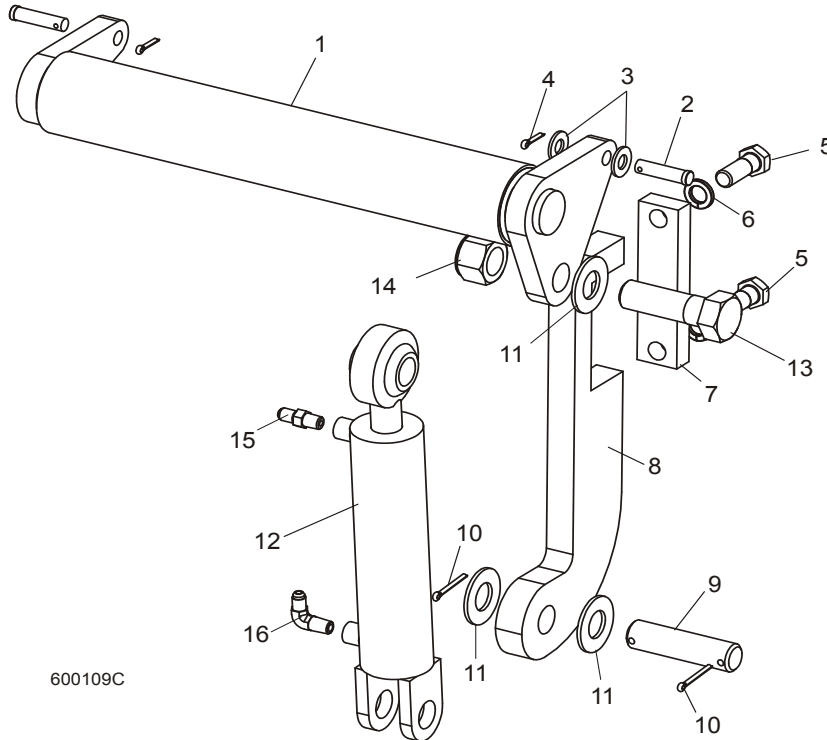

600109C

REF	DESCRIPTION (◆ Indicates Parts Available In Assemblies Only)	PART #	QTY.
1	TOE BOARD WELDMENT, HYDRAULIC	W13025	2
2	PIN, 1/2-1 3/4 CLEVIS	F05012-82	4
3	WASHER, 1/2" SAE FLAT	F05011-2	4
4	PIN, 1/8 X 3/4" COTTER	F05012-3	4
5	BOLT, 5/8-11 X 1 3/4" HEX HEAD	F05009-33	4
6	WASHER, 5/8" SPLIT LOCK	F05011-27	4
7	PLATE, HYDRAULIC TOEBOARD MOUNT	S13023	2
8	BRACKET, HYDRAULIC TOEBOARD MOUNT	S13022	2
9	PIN, CYLINDER MOUNT	S09251	2
10	PIN, 3/16" X 1 1/2" COTTER	F05012-23	4
11	WASHER, 1" SAE FLAT	F05011-28	6
12	CYLINDER, 1 1/2" X 6" HYDRAULIC TOE BOARD	014482	2
	Seal Kit, 1 1/2" x 6" Hydraulic Cylinder	014547	1
13	BOLT, 1-8 X 3 1/4" HEX HEAD GRADE 5	F05009-51	2
14	NUT, 1-8 HEX NYLON LOCK	F05010-109	2
15	FITTING, 1/4" NPT X 1/4" JIC MALE	P09143	2
16	FITTING, 1/4" NPT X 1/4" JIC MALE ELBOW	P09142	2

# INDEX

---

## B

battery box 5-10, 5-12

bed rails

- front/rear 8-1
- middle front 8-3
- middle rear 8-4
- pivot 8-9

blade guide arm 2-15, 2-16

drive 2-13

blade guides

- drive side roller 2-7, 2-10
- idle side roller 2-1, 2-4
- throat screw 4-1

blade tensioner 3-4

blade wheels

- drive side 3-1
- idle side 3-3

board return 4-5

board return table 8-8

brake assembly 4-4

---

## C

clutch mount 4-3

control box 5-1

- circuit breakers 5-7
- cover assembly 5-4
- drum switches 5-6

covers

- blade housing 4-10
- drive belt 4-12

---

## D

decals

- frame 8-13, 8-14
  - saw head 4-9
- 

## F

feed chain 7-5, 7-6

fuse box 5-14, 5-16

---

## H

hydraulic

- hoses 10-1, 10-2
  - log clamp 10-19
  - log loader 10-8
  - log turner 10-10, 10-12
  - power strip 10-6
  - side supports 10-14
  - side supports (link) 10-18
  - side supports (rear) 10-16
  - toe board 10-21
- 

## M

manuals 9-1

---

## O

outfeed table option 8-15

---

## P

parts list

- how to use 1-1

power feed 7-3

---

---

## R

rest pin 8-12

---

## S

sawdust chute 4-13

---

## T

track rollers  
    lower 7-7  
    upper 7-1

---

## U

up/down  
    blade scales 6-2  
    chain & sprockets 6-4  
    drive 6-7  
    motor 6-6  
    saw head mount 6-1

---

## W

water lube  
    bottle/tray 4-7  
    valve 4-2

---