



Wood-Mizer[®] Sawmill

Parts Manual

LT70HD Remote rev. A1.00 - A3.00



Safety is our #1 concern! Read and understand all safety information and instructions before operating, setting up or maintaining this machine.

January 1999

Form #1056

Table of Contents

Section-Page

SECTION 1	GENERAL INFORMATION	1-1
1.1	How To Use The Parts List	1-1
1.2	Sample Assembly	1-1
SECTION 2	BLADE GUIDE ROLLERS & ARM	2-1
2.1	Blade Guide Assembly, Idle Side..... <i>LT70HD Remote Retrofit</i>	2-1
2.2	Blade Guide Assembly, Idle Side..... <i>LT70HD Remote Rev. A1.07 - A3.00</i>	2-4
2.3	Blade Guide Assembly, Idle Side..... <i>LT60HD Rev. A1.00 - A1.06</i> <i>LT70HD Remote Rev. A1.00 - A1.06</i>	2-7
2.4	Blade Guide Assembly, Drive Side..... <i>LT70HD Remote Retrofit</i>	2-10
2.5	Blade Guide Assembly, Drive Side..... <i>LT70HD Remote Rev. A1.07 - A3.00</i>	2-13
2.6	Blade Guide Assembly, Drive Side..... <i>LT70HD Remote Rev. A1.00 - A1.06</i>	2-16
2.7	Blade Guide Arm Drive Assembly.....	2-19
SECTION 3	BLADE WHEELS & TENSIONER	3-1
3.1	Blade Drive Assembly.....	3-1
3.2	Idle Blade Wheel Assembly	3-3
3.3	Hydraulic Blade Tensioner Assembly..... <i>LT70HD Remote Retrofit</i>	3-5
3.4	Blade Tensioner Assembly..... <i>LT70HD Remote Rev. A1.00 - A3.00</i>	3-8
SECTION 4	SAW HEAD	4-1
4.1	Middle Throat Screw	4-1
4.2	Belt Tensioner	4-2
4.3	Brake Assembly (DC Only)	4-4
4.4	Autoclutch Assembly (DC Only)	4-5
4.5	Board Return Assembly	4-7
	<i>LT60HD/70HD Rev. A2.02 - A3.00</i>	
4.6	Board Return Assembly	4-8
	<i>LT60HD/70HD Rev. A2.00 - A2.01</i>	
4.7	Board Return Assembly	4-9
	<i>LT60HD/70HD Rev. A1.00 - A1.09</i>	
4.8	Board Dragback.....	4-10
	<i>LT60HD/70HD Retrofit</i>	
4.9	Board Dragback.....	4-11
	<i>LT60HD/70HD Rev. A1.00 - A3.00</i>	
4.10	Water Lube Assembly	4-1
4.11	Saw Head Decals.....	4-3

Table of Contents

Section-Page

4.12	Blade Housing Covers.....	4-4
	<i>LT60HD/70HD Rev. A2.00 - A3.00</i>	
4.13	Blade Housing Covers.....	4-6
	<i>LT60HD/70HD Rev. A1.00 - A1.09</i>	
4.14	Sawdust Chute.....	4-8
4.15	Debarker Wire Box/Grommet.....	4-9
SECTION 5	CONTROL & BATTERY BOXES	5-1
5.1	Control Assembly (DC).....	5-1
	<i>LT70HD Remote Rev. A2.02 - A3.00</i>	
5.2	Control Assembly (DC).....	5-4
	<i>LT70HD Remote Rev. A1.09 - A2.01</i>	
5.3	Control Assembly (DC).....	5-7
	<i>LT70HD Remote Rev. A1.00 - A1.08</i>	
5.4	Control Assembly (AC).....	5-10
	<i>LT70HD Remote Rev. A2.02 - A3.00</i>	
5.5	Control Assembly (AC).....	5-13
	<i>LT70HD Remote Rev. A1.09 - A2.01</i>	
5.6	Control Assembly (AC).....	5-16
	<i>LT70HD Remote Rev. A1.00 - A1.08</i>	
5.7	Drum Switches.....	5-19
5.8	Front Panel Assembly.....	5-20
5.9	Battery Box Assembly (DC Only).....	5-22
5.10	Fuse Box Assembly (DC Only).....	5-24
5.11	Remote Power Box Assembly (DC).....	5-26
5.12	Remote Junction Box (AC).....	5-28
5.13	Remote Power Box Door Assembly (DC Only).....	5-30
SECTION 6	UP/DOWN SYSTEM	6-1
6.1	Up/Down Rollers & Covers.....	6-1
	<i>LT60HD/70HD Remote Rev. A2.00 - A3.00</i>	
6.2	Up/Down Rollers & Covers.....	6-3
	<i>LT60HD/70HD Remote Rev. A1.00 - A1.09</i>	
6.3	Blade Height & Quarter Scales.....	6-5
6.4	Up/Down Chain & Sprockets.....	6-6
6.5	Up/Down Drive Assembly.....	6-8
	<i>LT70HD Remote Rev. A2.00 - A3.00</i>	
6.6	Up/Down Drive Assembly.....	6-10
	<i>LT70HD Remote Rev. A1.09</i>	
6.7	Up/Down Drive Assembly.....	6-12
	<i>LT70HD Remote Rev. A1.00 - A1.08</i>	
SECTION 7	FEED SYSTEM & TRACK ROLLERS	7-1
7.1	Upper Track Rollers And Wipers.....	7-1

Table of Contents

Section-Page

7.2	Power Feed Assembly	7-3	
7.3	Feed Chain/Stop	7-5	
7.4	Lower Track Rollers.....	7-6	
	<i>LT70HD Remote Rev. A3.00</i>		
7.5	Lower Track Rollers.....	7-8	
	<i>LT70HD Remote Rev. A1.00 - A2.04</i>		
SECTION 8	BED FRAME ASSEMBLY		8-1
8.1	Bed Rail Assembly, Front And Rear	8-1	
8.2	Bed Rail Assembly, Middle Front.....	8-3	
8.3	Bed Rail Assembly, Middle Rear	8-4	
8.4	Leg Assembly (Stationary).....	8-6	
	<i>LT15BS Rev. E.00+</i>		
8.5	Board Return Table Assembly	8-8	
	<i>LT70HD Remote Rev. A2.02 - A3.00</i>		
8.6	Board Return Table Assembly	8-10	
	<i>LT70HD Remote Rev. A1.00 - A2.01</i>		
8.7	Pivot Bed Rail Assembly.....	8-11	
8.8	Log Side Support Assembly (Manual).....	8-13	
8.9	Safety Chain Assembly	8-15	
8.10	Saw Head Rest Pin Assembly	8-16	
8.11	Bed Frame Decals.....	8-17	
8.12	Cable Chain Assembly	8-18	
	<i>LT70HD Remote Rev. A1.09 - A3.00</i>		
8.13	Cable Chain Assembly	8-19	
	<i>LT70HD Remote Rev. A1.00 - A1.08</i>		
8.14	Bottom Chain Mount Assembly	8-20	
8.15	Top Chain Mount Assembly	8-21	
8.16	Front Tray Mount Assembly	8-22	
8.17	Cable Chain Support Bracket	8-23	
8.18	Remote Cable Box.....	8-24	
SECTION 9	MISCELLANEOUS		9-1
9.1	Replacement Manuals	9-1	
SECTION 10	HYDRAULIC SYSTEM		10-1
10.1	Hydraulic Hoses	10-1	

Table of Contents

Section-Page

10.2	Command Control	10-2
	<i>LT70HD Remote Rev. A1.09 - A3.00</i>	
10.3	Command Control	10-4
	<i>LT70HD Remote Rev. A1.00 - A1.08</i>	
10.4	Hydraulic Pump Box (DC).....	10-6
10.5	Hydraulic Pump Box (AC).....	10-9
10.6	Hydraulic Control Box (230/460V AC).....	10-11
10.7	Hydraulic Control Box (575V AC).....	10-13
10.8	Hydraulic Valve (DC)	10-15
10.9	Hydraulic Valve (AC)	10-17
10.10	Hydraulic Power Supply Strip (DC Only).....	10-19
10.11	Hydraulic Power Supply Strip (AC Only).....	10-21
	<i>Rev. A1.00 - A1.05</i>	
10.12	Hydraulic Log Loader	10-23
	<i>LT70HD Remote Rev. A2.03+</i>	
10.13	Hydraulic Log Loader	10-25
	<i>LT70HD Remote Rev. A1.00 - A2.02</i>	
10.14	Hydraulic Log Turner.....	10-27
	<i>LT60HD/LT70HD Rev. A1.04 - A3.00</i>	
10.15	Hydraulic Log Turner.....	10-29
	<i>LT60HD/LT70HD Rev. A1.00 - A1.03</i>	
10.16	Hydraulic Log Side Supports (Front).....	10-31
	<i>LT60HD/LT70HD Rev. A1.04 - A3.00</i>	
10.17	Hydraulic Log Side Supports (Front).....	10-33
	<i>LT60HD/LT70HD Rev. A1.00 - A1.03</i>	
10.18	Hydraulic Log Side Supports (Rear).....	10-35
10.19	Hydraulic Log Side Supports (Link).....	10-37
10.20	Hydraulic Log Clamp	10-38
10.21	Hydraulic Toe Board	10-40

INDEX

I

SECTION 1 GENERAL INFORMATION

1.1 How To Use The Parts List

- Use the table of contents or index to locate the assembly that contains the part you need.
- Go to the appropriate section and locate the part in the illustration.
- Use the number pointing to the part to locate the correct part number and description in the table.
- Parts shown indented under another part are included with that part.
- Parts marked with a diamond (◆) are only available in the assembly listed above the part.

See the sample table below. Sample Part #A01111 includes part F02222-2 and subassembly A03333. Subassembly A03333 includes part S04444-4 and subassembly K05555. The diamond (◆) indicates that S04444-4 is not available except in subassembly A03333. Subassembly K05555 includes parts M06666 and F07777-77. The diamond (◆) indicates M06666 is not available except in subassembly K05555.

1.2 Sample Assembly				
REF	DESCRIPTION (◆ Indicates Parts Available In Assemblies Only)	PART #	QTY.	
	SAMPLE ASSEMBLY, COMPLETE (INCLUDES ALL INDENTED PARTS BELOW)	A01111	1	
1	Sample Part	F02222-22	1	
	Sample Subassembly (Includes All Indented Parts Below)	A03333	1	
2	Sample Part (◆ Indicates Part Is Only Available With A03333)	S04444-4	1	◆
	Sample Subassembly (Includes All Indented Parts Below)	K05555	1	
3	Sample Part (◆ Indicates Part Is Only Available With K05555)	M06666	2	◆
4	Sample Part	F07777-77	1	

To Order Parts:

- From the continental U.S., call **1-800-525-8100** to order parts. Have your customer number, vehicle identification number, and part numbers ready when you call.
- From other international locations, contact the Wood-Mizer distributor in your area for parts.

SECTION 2 BLADE GUIDE ROLLERS & ARM

2.1 Blade Guide Assembly, Idle Side

LT70HD Remote

Retrofit

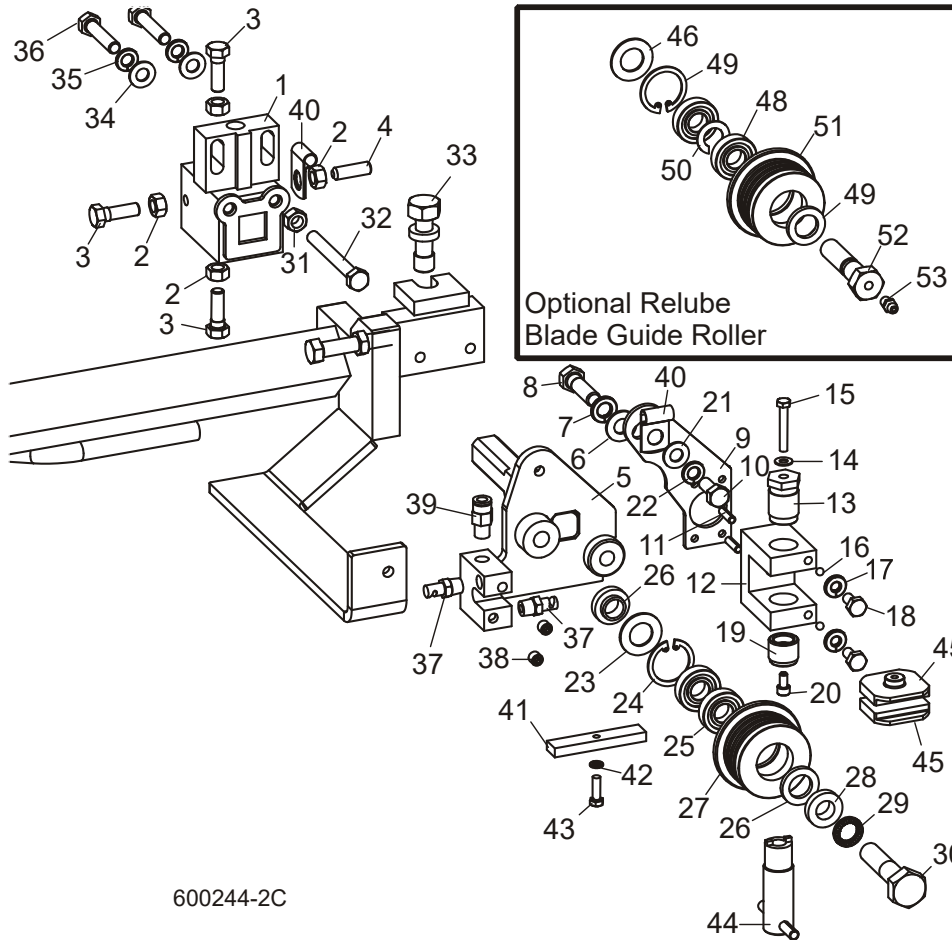

600244-2C

REF	DESCRIPTION (◆ Indicates Parts Available In Assemblies Only)	PART #	QTY.	
	ROLLER/BLOCK ASSEMBLY, IDLE SIDE (OUTER)	003926 ¹	1	
	Block Assembly, Blade Guide Mount	065677	1	
1	Block Weldment, Blade Guide Mount	003911	1	◆
2	Nut, 5/16-18 Hex	F05010-17	4	
3	Bolt, 5/16-18 x 1" Hex Head Stainless Steel	F05006-88	3	
4	Screw, 5/16-18 x 1" Socket Head Flat Point Stainless Steel Set	F05006-122	1	
5	Shaft Weldment, Idle Side Guide	003924 ²	1	
	Mount Assembly, Blade Guide Block Idle	003928	1	
6	Washer, 3/8" SAE Flat	F05011-3	1	
7	Washer, 3/8" Split Lock	F05011-4	1	

2

Blade Guide Rollers & Arm

Blade Guide Assembly, Idle Side

8	Bolt, 3/8-16 x 1 1/4" Hex Head Grade 5	F05007-123	1	
9	Plate, Block Tilt Adjustment	003915	1	
10	Bolt, 5/16-18 x 3/4" Hex Head	F05006-102	1	
11	Pin, 3/16" x 5/8" Roll	F05012-22	2	
12	Block, Guide Block Mount	003909	1	
13	Bolt, Blade Guide Block Mount	003994	1	
14	Washer, #10 Brass	042867	1	
15	Bolt, #10-32 x 1 1/4" Hex Head Stainless Steel	F05004-240	1	
16	Ball, 3/16" Dia. Nylon	003914	2	
17	Washer, 1/4" Split Lock	F05011-14	2	
18	Bolt, 1/4-20 x 1/2" Hex Head	F05005-15	2	
19	Screw, Lower Block Adjustment	044057	1	
20	Screw, #10-32 x 3/8" Socket Head Stainless Steel	F05004-200	1	
21	Washer, 5/16" SAE Flat	F05011-17	1	
22	Washer, 5/16" Split Lock	F05011-13	1	
	Roller Assembly, Blade Guide (standard for use with 1 1/4" & 1 1/2" blades)	A04925 ³	1	
	Roller Assembly, Extended Blade Guide (optional for use with 1 1/2" blades)	014299 ³	1	
	Bearing Kit, Blade Guide Rebuild	K07079	1	
23	Washer, 5/8" White Felt	P04252	1	
24	Ring, 1 1/8" Interior Retaining	F04254-1	1	
25	Bearing, R8-2RS Blade Guide	015975	2	◆
26	Washer, 5/8" Gray Felt	P06455	1	
	Screw, 1/4-28 x 1/4" Socket Head Cup Point Set Black Oxide	F05005-105	1	
	Instruction Sheet, Blade Guide Rebuild	057407-1507	1	
27	Roller, Flanged Blade Guide (1 1/4" & 1 1/2" blade)	S04250	1	◆
	Roller, Flanged Blade Guide (1 1/2" blade)	014243	1	◆
	Instruction Sheet, Blade Guide Roller Replacement	A04925-364	1	
28	Spacer, Blade Guide	S04253	2	
29	Washer, 1/2" Nord-Lock	F05011-125 ⁴	1	
30	Bolt, 1/2-13 x 2 1/4" Hex Head Grade 5	F05008-10	1	
31	Nut, 5/16-18 Hex	F05010-17	1	
32	Bolt, 5/16-18 x 2 3/4" Hex Head Full Thread	F05006-136	1	
33	Bolt, Blade Guide Vertical Adjustment	035656	1	
34	Washer, 5/16" SAE Flat	F05011-17	2	
35	Washer, 5/16" Split Lock	F05011-13	2	
36	Bolt, 5/16-18 x 1 1/2" Hex Head Grade 5 Full Thread	F05006-76	2	
37	Fitting, Blade Lube Spray Nozzle	033479	2	
38	Fitting, 1/16" NPT Socket Pipe Plug	007734 ²	2	
39	Fitting, 1/8" NPT x 1/4" Tube	P03078 ⁵	1	
40	Clamp, 1/4" Wire 13/32" Mounting Hole	024155 ⁵	2	
41	BLOCK, BLADE GUIDE ALIGNMENT	035799	1	
42	SCREW, #10-32 X 5/8" HEX HEAD	F05004-152	1	

43	WASHER, #10 SPLIT LOCK	F05011-20	1	
44	TOOL, LOWER BLOCK ADJUSTMENT	044064	1	
45	BLOCK, BLADE GUIDE WEAR (STANDARD FOR 1 1/2" BLADES)	052309 ⁶	2	
	BLOCK, BLADE GUIDE WEAR (OPTIONAL FOR 1 1/4" BLADES)	052355 ⁶	2	
	BLOCK ASSEMBLY, 1" SQ. EZ-GLIDE WEAR	036347 ⁶	2	
	SHIM, .008" BLADE GUIDE BLOCK SPACER	035248	1	
	ROLLER ASSEMBLY, BLADE GUIDE RELUBE (OPTIONAL FOR USE WITH 1 1/4" & 1 1/2" BLADES)	016568 ³	1	
	ROLLER ASSEMBLY, EXTENDED BLADE GUIDE RELUBE (OPTIONAL FOR USE WITH 1 1/2" BLADES)	057405 ³	1	
	Bearing Kit, Relube Blade Guide Rebuild	057407	1	
46	Washer, 5/8" White Felt	P04252	1	
47	Ring, 1 1/8" Interior Retaining	F04254-1	1	
48	Bearing, R8-2RS Blade Guide (modified)	015975 ⁷	2	◆
49	Washer, 5/8" Gray Felt	P06455	1	
50	Spacer, Blade Guide Bearing	035411	1	
	Instruction Sheet, Blade Guide Rebuild	057407-1507	1	
51	Roller, Flanged Blade Guide (Relube 1 1/4" & 1 1/2" blade)	035426	1	◆
	Roller, Flanged Blade Guide (Relube 1 1/2" blade)	057402	1	◆
	Instruction Sheet, Blade Guide Roller Replacement	A04925-364	1	
52	BOLT, BLADE GUIDE ROLLER (RELUBE ONLY)	036161	1	
53	FITTING, 1/4-28 GREASE (RELUBE ONLY)	P05060	1	

¹ Roller/Block Assembly 003926 is no longer available. Use component parts to service or order Roller/Block Assembly 036818 for 1-1/4" blades or 065934 for 1-1/2 blades.

² Shaft Weldment 003924 modified to provide more clearance for adjustment bolts and to prevent water leaks (Rev. B3.01). New shaft requires two 1/16" NPT Pipe Plugs 007734.

³ The sawmill is equipped standard with non-greasable blade guide rollers that can be used with the standard 1 1/2" blade. The roller can also be used with 1 1/4" blades. Optional extended blade guide rollers are available for use with 1 1/2" blades. The extended rollers may provide more stability during difficult sawing, but will reduce the total amount of times the blade can be reused after sharpening. Optional relube versions of each roller configuration are also available.

⁴ Nord-Lock Washer F05011-125 replaced Split Lock Washer F05011-9 to prevent loosening due to vibration (Rev. B3.01).

⁵ Straight Tube Fitting P03078 replaced Swivel Hose Fitting P09736 and Clamps 024155 added to improve lube hose routing (Rev. B3.01).

⁶ 052309 blocks for use with 1 1/2" blade provided as standard equipment. 052355 blocks available for optional use with 1 1/4" blades. EZ-Glide blocks 036347 are available for customers who prefer this block

⁷ Bearing must be modified for use with relube roller assemblies. Remove one seal from each bearing, place open sides facing each other and place spacer 035411 between bearings.

2 Blade Guide Rollers & Arm

Blade Guide Assembly, Idle Side

2.2 Blade Guide Assembly, Idle Side

LT70HD Remote

Rev. A1.07 - A3.00

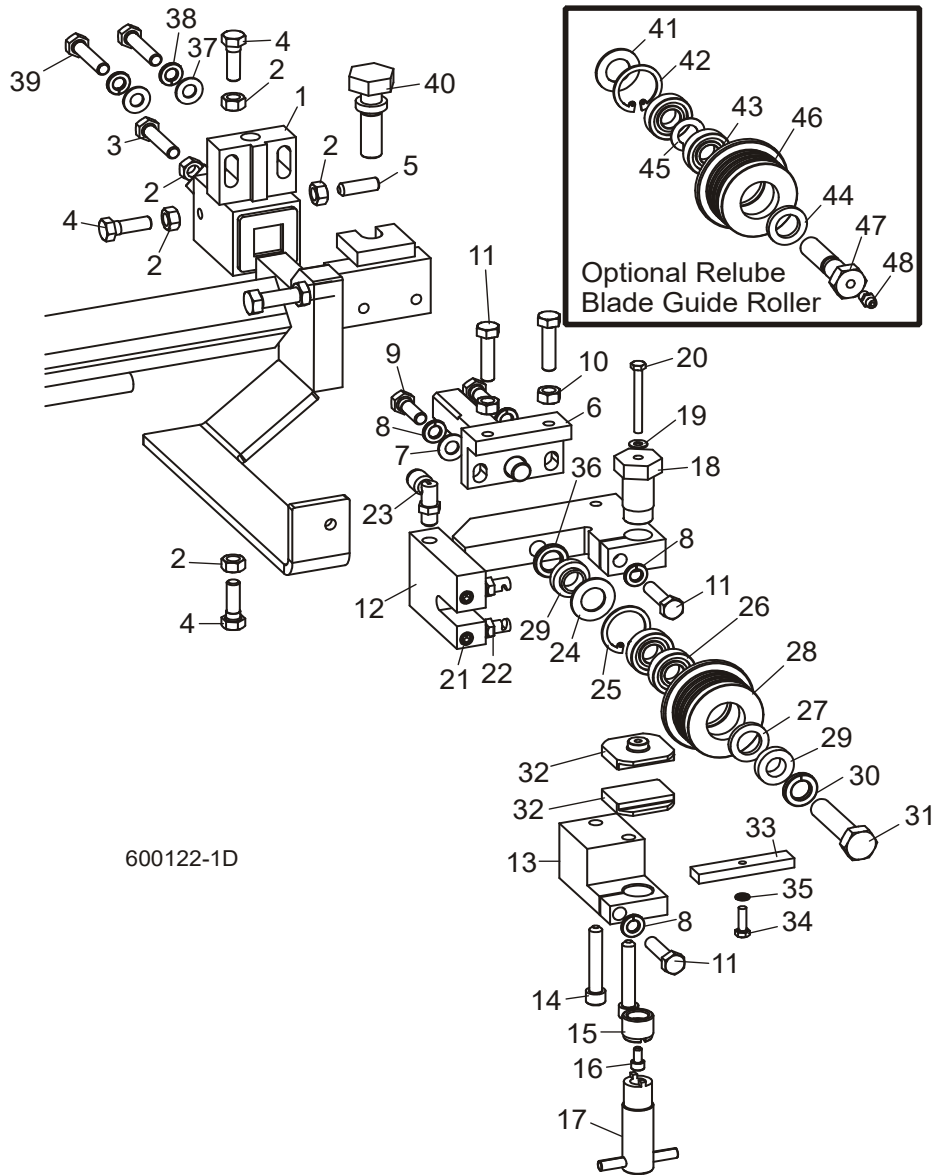

REF	DESCRIPTION (◆ Indicates Parts Available In Assemblies Only)	PART #	QTY.	
	GUIDE ASSEMBLY, IDLE SIDE BLOCK/ROLLER	044055	1	◆
	Block Assembly, Idle Side Blade Guide	036099	1	
1	Block Weldment, Blade Guide Mount	035219	1	◆
2	Nut, 5/16-18 Hex	F05010-17	5	
3	Bolt, 5/16-18 x 1 1/2" Hex Head Full Thread Stainless Steel	F05006-119	1	

Blade Guide Rollers & Arm

Blade Guide Assembly, Idle Side

2

4	Bolt, 5/16-18 x 1" Hex Head Stainless Steel	F05006-88	3	
5	Screw, 5/16-18 x 1" Socket Head Flat Point Stainless Steel	F05006-122	1	
6	Shaft Weldment, Block Guide Pivot	035209	1	
7	Washer, 5/16" SAE Flat	F05011-17	2	
8	Washer, 5/16" Split Lock	F05011-13	4	
9	Bolt, 5/16-18 x 1" Hex Head Stainless Steel	F05006-88	2	
10	Nut, 5/16-18 Hex	F05010-17	2	
11	Bolt, 5/16-18 x 1 1/4" Hex Head Stainless Steel	F05006-118	4	
12	Block Weldment, Upper Blade Guide	044054	1	
13	Block, Lower Blade Guide	044053	1	
14	Screw, 5/16-18 x 1 3/4" Socket Head	F05006-65	2	
15	Screw, Lower Block Adjustment	044057	1	
16	Screw, #10-32 x 3/8" Socket Head Stainless Steel	F05004-200	1	
17	Tool, Lower Block Adjustment	044064	1	
18	Bolt, Blade Guide Block Mount	035216	1	
19	Washer, #10 Brass	042867	1	
20	Bolt, #10-32 x 1 3/4" Hex Head Stainless Steel	F05004-178	1	
21	Fitting, 1/8" NPT Socket Pipe Plug	P30127	2	
22	Fitting, Blade Lube Spray Nozzle	033479	2	
23	Fitting, 1/8" MPT x 1/4" Tube Swivel Elbow	P09736	1	
	Roller Assembly, Blade Guide (standard for use with 1 1/4" & 1 1/2" blades)	A04925 ²	1	
	Roller Assembly, Extended Blade Guide (optional for use with 1 1/2" blades)	014299 ²	1	
	Bearing Kit, Blade Guide Rebuild	K07079	1	
24	Washer, 5/8" White Felt	P04252	1	
25	Ring, 1 1/8" Interior Retaining	F04254-1	1	
26	Bearing, R8-2RS Blade Guide	015975	2	◆
27	Washer, 5/8" Gray Felt	P06455	1	
	Screw, 1/4-28 x 1/4" Socket Head Cup Point Set Black Oxide	F05005-105	1	
	Instruction Sheet, Blade Guide Rebuild	057407-1507	1	
28	Roller, Flanged Blade Guide (1 1/4" & 1 1/2" blade)	S04250	1	◆
	Roller, Flanged Blade Guide (1 1/2" blade)	014298	1	◆
	Instruction Sheet, Blade Guide Roller Replacement	A04925-364	1	
29	Spacer, Blade Guide	S04253	2	
30	Washer, 1/2" Split Lock	F05011-9 ³	1	
31	Bolt, Blade Guide Roller	036399	1	
32	Block, Blade Guide Wear (Standard for 1 1/2" Blades)	052309 ⁴	2	
	Block, Blade Guide Wear (Optional for 1 1/4" Blades)	052355 ³	2	
	Block Assembly, 1" Sq. EZ-Glide Wear	036347 ³	2	
33	Block, Blade Guide Alignment	035799	1	
34	Screw, #10-32 x 5/8" Hex Head	F05004-152	1	
35	Washer, #10 Split Lock	F05011-20	1	
36	Spacer, 1/2" ID x 7/8" OD x 1/8" Thick (For use with 1 1/4" Blades Only)	052364 ⁵	1	

2

Blade Guide Rollers & Arm*Blade Guide Assembly, Idle Side*

	SHIM, .008" CERAMIC INSERT SPACER	035248	1	
37	WASHER, 5/16" SAE FLAT	F05011-17	2	
38	WASHER, 5/16" SPLIT LOCK	F05011-13	2	
39	BOLT, 5/16-18 X 1 1/2" HEX HEAD GRADE 5 FULL THREAD	F05006-76	2	
40	BOLT, BLADE GUIDE VERTICAL ADJUSTMENT	035656	1	
	ROLLER ASSEMBLY, BLADE GUIDE RELUBE (OPTIONAL FOR USE WITH 1 1/4" & 1 1/2" BLADES)	016568 ²	1	
	ROLLER ASSEMBLY, EXTENDED BLADE GUIDE RELUBE (OPTIONAL FOR USE WITH 1 1/2" BLADES)	057405 ²	1	
	Bearing Kit, Relube Blade Guide Rebuild	057407	1	
41	Washer, 5/8" White Felt	P04252	1	
42	Ring, 1 1/8" Interior Retaining	F04254-1	1	
43	Bearing, R8-2RS Blade Guide	015975 ⁶	2	◆
44	Washer, 5/8" Gray Felt	P06455	1	
45	Spacer, Blade Guide Bearing	035411	1	
	Instruction Sheet, Blade Guide Rebuild	057407-1507	1	
46	Roller, Flanged Blade Guide (Relube 1 1/4" & 1 1/2" blade)	035426	1	◆
	Roller, Flanged Blade Guide (Relube 1 1/2" blade)	057402	1	◆
	Instruction Sheet, Blade Guide Roller Replacement	A04925-364	1	
47	BOLT, BLADE GUIDE ROLLER (RELUBE ONLY)	036161	1	
48	FITTING, 1/4-28 GREASE (RELUBE ONLY)	P05060	1	

² The sawmill is equipped standard with non-greasable blade guide rollers that can be used with the standard 1 1/2" blade. The roller can also be used with 1 1/4" blades (requires spacer 052364). Optional extended blade guide rollers are available for use with 1 1/2" blades. The extended rollers may provide more stability during difficult sawing, but will reduce the total amount of times the blade can be reused after sharpening. Optional relube versions of each roller configuration are also available.

³ Nord-Lock Washer F05011-125 available to replace Split Lock Washer F05011-9 to prevent loosening due to vibration (12/09).

⁴ Blade guide wear blocks 052309 & 052355 replace EZ-Glide block 036347 originally supplied to improve wear life. 052309 blocks for use with 1 1/2" blade provided as standard equipment. 052355 blocks available for optional use with 1 1/4" blades. EZ-Glide blocks 036347 are available for customers who prefer this block. EZ-Glide pad assembly 036347 replaced Wear Pad assembly 042860 supplied prior to Rev. A3.00. New pad is cost effective and contributes to longer blade life.

⁵ 1/8" thick spacer 052364 replaces 1/4" spacer 041626 to provide proper spacing of blade guide block when using 1 1/4" blades.

⁶ Bearing must be modified for use with relube roller assemblies. Remove one seal from each bearing, place open sides facing each other and place spacer 035411 between bearings.

2.3 Blade Guide Assembly, Idle Side

LT60HD

LT70HD Remote

Rev. A1.00 - A1.06

Rev. A1.00 - A1.06

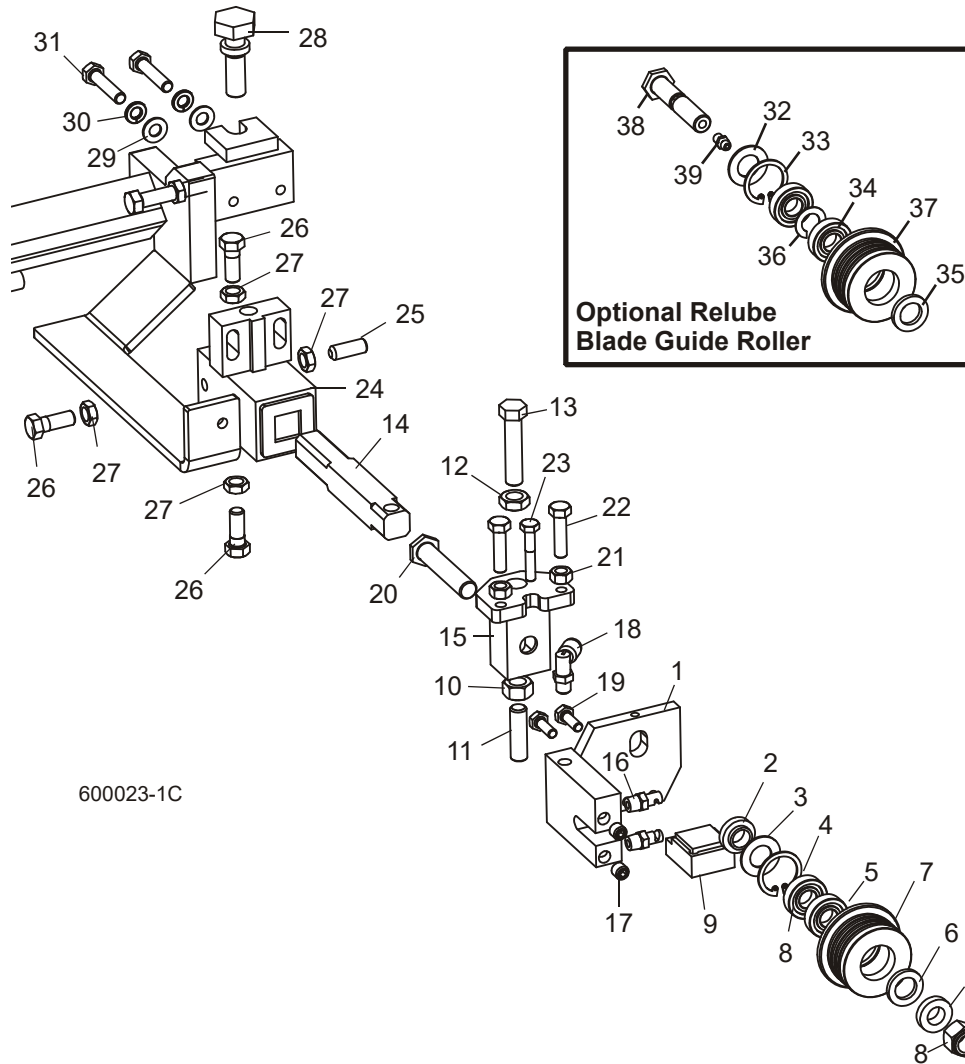

600023-1C

REF	DESCRIPTION (◆ Indicates Parts Available In Assemblies Only)	PART #	QTY.	
	ROLLER/BLOCK ASSEMBLY, IDLE SIDE (OUTER)	017807 ¹	1	◆
1	Nozzle Block Weldment, Idle Side	035404	1	
2	Spacer, .510 x .937 x .34	S04253	2	
	Roller Assembly, Blade Guide (standard for use with 1 1/4" or 1 1/2" blades)	A04925 ²	1	
	Roller Assembly, Blade Guide (optional for use with 1 1/2" blades)	014299 ²	1	
	Bearing Kit, Blade Guide Rebuild	K07079	1	
3	Washer, 5/8" White Felt	P04252	1	
4	Ring, 1 1/8" Interior Retaining	F04254-1	1	

2

Blade Guide Rollers & Arm*Blade Guide Assembly, Idle Side*

5	Bearing, R8-2RS Blade Guide	015975	2	◆
6	Washer, 5/8" Gray Felt	P06455	1	
	Screw, 1/4-28 x 1/4" Socket Head Cup Point Set Black Oxide	F05005-105	1	
	Instruction Sheet, Blade Guide Rebuild	057407-1507	1	
7	Roller, Flanged Blade Guide (1 1/4" & 1 1/2" blade)	S04250	1	◆
	Roller, Flanged Blade Guide (1 1/2" blade)	014298	1	◆
	Instruction Sheet, Blade Guide Roller Replacement	A04925-364	1	
8	Nut, 1/2-20 Nylon Hex Lock	F05010-15	1	
9	Block Assembly, 1 1/4" Blade EZ-Glide Wear	036247 ³	1	
	Block, 1 1/4" Blade Guide Wear	052367 ³	1	
	Block, 1 1/2" Blade Guide Wear	052366 ³	1	
	Shaft Kit, Blade Guide Adjust Retrofit	038972 ⁴	1	
10	Nut, 7/16-20 Hex	F05010-202 ⁵	1	
11	Screw, 7/16-20 x 1 1/2" Socket Head Cup Point Stainless Steel	F05007-217 ⁶	1	
12	Nut, 7-16-20 Hex Jam	F05010-38	1	
13	Bolt, 7/16-20 x 2" Hex Head Full Thread Grade 8	F05007-215	1	
14	Shaft, Blade Guide Mount	038970	1	
15	Block Weldment, Roller Guide Adjuster	054969	1	
16	Nozzle, Blade Lube Spray	033479	2	
17	Fitting, 1/8" NPT Socket Pipe Plug	P30127	2	
18	Fitting, 1/8" MPT x 1/4" Tube 90° Elbow Swivel	P09736	1	
19	Bolt, 1/4-20 x 3/4" Hex Head Grade 5	F05005-123	2	
20	Bolt, Blade Guide Roller	036374	1	
21	Nut, 5/16-24 Hex	F05010-28	2	
22	Bolt, 5/16-24 x 1 1/4" Hex Head Full Thread Grade 5	F05006-107	2	
23	Bolt, 1/4-28 x 1 1/2" Hex Head Grade 5	F05005-143	1	
24	Block Weldment, Guide Mounting 60/70	044044	1	
25	Screw, 3/8-24 x 1" Socket Head Flat Point Stainless Steel Set	F05007-184 ⁷	1	
26	Bolt, 3/8-24 x 1" Hex Head Stainless Steel	F05007-99 ⁷	3	
27	Nut, 3/8-24 UNC Hex Jam	F05010-22	4	
	SHIM, .008" CERAMIC INSERT SPACER	035248	1	
28	BOLT, BLADE GUIDE VERTICAL ADJUSTMENT	035656	1	
29	WASHER, 5/16" SAE FLAT	F05011-17	2	
30	WASHER, 5/16" SPLIT LOCK	F05011-13	2	
31	BOLT, 5/16-18 X 1 1/2" FULL THREAD HEX HEAD GRADE 5	F05006-76	2	
	ROLLER ASSEMBLY, BLADE GUIDE RELUBE (OPTIONAL FOR USE WITH 1 1/4" & 1 1/2" BLADES)	016568 ¹	1	
	ROLLER ASSEMBLY, EXTENDED BLADE GUIDE RELUBE (OPTIONAL FOR USE WITH 1 1/2" BLADES)	057405 ¹	1	
	Bearing Kit, Relube Blade Guide Rebuild	057407	1	
32	Washer, 5/8" White Felt	P04252	1	
33	Ring, 1 1/8" Interior Retaining	F04254-1	1	

Blade Guide Rollers & Arm

Blade Guide Assembly, Idle Side

2

34	Bearing, R8-2RS Blade Guide	015975 ⁸	2	◆
35	Washer, 5/8" Gray Felt	P06455	1	
36	Spacer, Blade Guide Bearing	035411	1	
	Instruction Sheet, Blade Guide Rebuild	057407-1507	1	
37	Roller, Flanged Blade Guide (Relube 1 1/4" & 1 1/2" blade)	035426	1	◆
	Roller, Flanged Blade Guide (Relube 1 1/2" blade)	057402	1	◆
	Instruction Sheet, Blade Guide Roller Replacement	A04925-364	1	
38	BOLT, BLADE GUIDE ROLLER (RELUBE ONLY)	035412	1	
39	FITTING, 1/4-28 GREASE (RELUBE ONLY)	P05060	1	

¹ 017807 Blade Guide Assembly replaced with 036818 12/05 then 003926 1/08 and no longer available. Use component parts to service or replace entire assembly with 003926. New assembly provides easier adjustment ([See Section 2.1](#)). Blade Guide Assembly 017807 upgraded with new Block Weldment and Shaft to accommodate 7/16" adjustment hardware to improve durability (12/06). Use kit 038972 to retrofit previous revisions.

² The sawmill is equipped standard with non-greasable blade guide rollers that can be used with the standard 1 1/2" blade. The roller can also be used with 1 1/4" blades (requires spacer 052364). Optional extended blade guide rollers are available for use with 1 1/2" blades. The extended rollers may provide more stability during difficult sawing, but will reduce the total amount of times the blade can be reused after sharpening. Optional relube versions of each roller configuration are also available.

³ Wear Block 052367 available 10/07 and provided as standard 4/09. Use to replace ceramic guide block 035222, screw F05004-71 & mount block 035235 originally supplied. EZ-Glide Block 036247 available for customers who prefer this block. Wear Block 052366 available for optional use with 1 1/2" blades.

⁴ Mount Shaft 044047, Adjuster Block 035408, 3/8" Set Screws F05007-162 & 3/8" Jam Nuts F05010-22 replaced with 7/16" adjustment hardware. Mount Shaft 044047 & Adjuster Block 035408 no longer available. Use kit 038972 to retrofit original parts.

⁵ Lower jam nut F05010-38 replaced with hex nut F05010-202 (3/07).

⁶ Stainless Set Screw replaces Zinc plated screw F05007-213 used prior to 6/07 to eliminate screw shearing.

⁷ Replaces four F05007-96 originally supplied prior to Rev. A1.02.

⁸ Bearing must be modified for use with relube roller assemblies. Remove one seal from each bearing, place open sides facing each other and place spacer 035411 between bearings.

2 Blade Guide Rollers & Arm

Blade Guide Assembly, Drive Side

2.4 Blade Guide Assembly, Drive Side

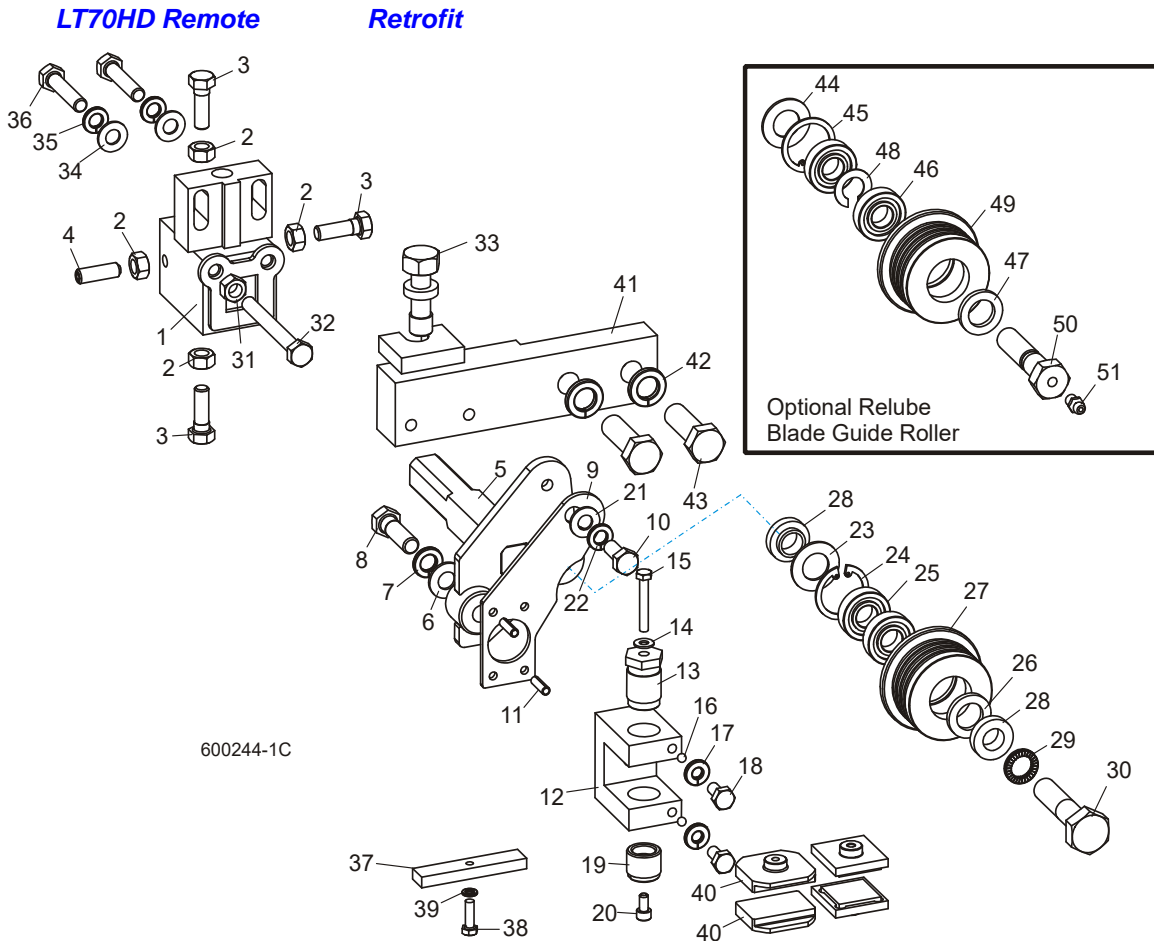

REF	DESCRIPTION (◆ Indicates Parts Available In Assemblies Only)	PART #	QTY.
	ROLLER/BLOCK ASSEMBLY, DRIVE SIDE (INNER)	003925 ¹	1
	Block Assembly, Blade Guide Mount	003910	1
1	Block Weldment, Blade Guide Mount	003911	1
2	Nut, 5/16-18 Hex	F05010-17	4
3	Bolt, 5/16-18 x 1" Hex Head Stainless Steel	F05006-88	3
4	Screw, 5/16-18 x 1" Socket Head Flat Point Stainless Steel Set	F05006-122	1
5	Shaft Weldment, Drive Side Guide	003913	1
	Mount Assembly, Blade Guide Block Drive	003927	1
6	Washer, 3/8" SAE Flat	F05011-3	1
7	Washer, 3/8" Split Lock	F05011-4	1
8	Bolt, 3/8-16 x 1 1/4" Hex Head Grade 5	F05007-123	1
9	Plate, Block Tilt Adjustment	003915	1
10	Bolt, 5/16-18 x 3/4" Hex Head	F05006-102	1
11	Pin, 3/16" x 5/8" Roll	F05012-22	2

Blade Guide Rollers & Arm

Blade Guide Assembly, Drive Side

2

12	Block, Guide Block Mount	003909	1	
13	Bolt, Blade Guide Block Mount	003994	1	
14	Washer, #10 Brass	042867	1	
15	Bolt, #10-32 x 1 1/4" Hex Head Stainless Steel	F05004-240	1	
16	Ball, 3/16" Dia. Nylon	003914	2	
17	Washer, 1/4" Split Lock	F05011-14	2	
18	Bolt, 1/4-20 x 1/2" Hex Head	F05005-15	2	
19	Screw, Lower Block Adjustment	044057	1	
20	Screw, #10-32 x 3/8" Socket Head Stainless Steel	F05004-200	1	
21	Washer, 5/16" SAE Flat	F05011-17	1	
22	Washer, 5/16" Split Lock	F05011-13	1	
	Roller Assembly, Blade Guide (standard for use with 1 1/4" & 1 1/2" blades)	A04925 ²	1	
	Roller Assembly, Extended Blade Guide (optional for use with 1 1/2" blades)	014299 ²	1	
	Bearing Kit, Blade Guide Rebuild	K07079	1	
23	Washer, 5/8" White Felt	P04252	1	
24	Ring, 1 1/8" Interior Retaining	F04254-1	1	
25	Bearing, R8-2RS Blade Guide	015975	2	◆
26	Washer, 5/8" Gray Felt	P06455	1	
	Screw, 1/4-28 x 1/4" Socket Head Cup Point Set Black Oxide	F05005-105	1	
	Instruction Sheet, Blade Guide Rebuild	057407-1507	1	
27	Roller, Flanged Blade Guide (1 1/4" & 1 1/2" blade)	S04250	1	◆
	Roller, Flanged Blade Guide (1 1/2" blade)	014243	1	◆
	Instruction Sheet, Blade Guide Roller Replacement	A04925-364	1	
28	Spacer, Blade Guide	S04253	2	
29	Washer, 1/2" Nord-Lock	F05011-125 ³	1	
30	Bolt, 1/2-13 x 2 1/4" Hex Head Grade 5	F05008-10	1	
31	Nut, 5/16-18 Hex	F05010-17	1	
32	Bolt, 5/16-18 x 2 3/4" Hex Head Full Thread	F05006-136	1	
33	Bolt, Blade Guide Vertical Adjustment	035656	1	
34	Washer, 5/16" SAE Flat	F05011-17	2	
35	Washer, 5/16" Split Lock	F05011-13	2	
36	Bolt, 5/16-18 x 1 1/2" Hex Head	F05006-76	2	
37	BLOCK, BLADE GUIDE ALIGNMENT	035799	1	
38	SCREW, #10-32 X 5/8" HEX HEAD	F05004-152	1	
39	WASHER, #10 SPLIT LOCK	F05011-20	1	
40	BLOCK, BLADE GUIDE WEAR (STANDARD FOR 1 1/2" BLADES)	052309 ⁴	2	
	BLOCK, BLADE GUIDE WEAR (OPTIONAL FOR 1 1/4" BLADES)	052355 ⁴	2	
	BLOCK ASSEMBLY, 1" SQ. EZ-GLIDE WEAR	036347 ⁴	2	
41	ARM WELDMENT, DRIVE SIDE BLADE GUIDE	034292	1	
42	WASHER, 1/2" SPLIT LOCK	F05011-9	2	
43	BOLT, 1/2-13 X 1 1/2" HEX HEAD GRADE 5	F05008-33	2	
	SHIM, .008" BLADE GUIDE BLOCK SPACER	035248	1	

2 Blade Guide Rollers & Arm

Blade Guide Assembly, Drive Side

	ROLLER ASSEMBLY, BLADE GUIDE RELUBE (OPTIONAL FOR USE WITH 1 1/4" & 1 1/2" BLADES)	016568 ²	1	
	ROLLER ASSEMBLY, EXTENDED BLADE GUIDE RELUBE (OPTIONAL FOR USE WITH 1 1/2" BLADES)	057405 ²	1	
	Bearing Kit, Relube Blade Guide Rebuild	057407	1	
44	Washer, 5/8" White Felt	P04252	1	
45	Ring, 1 1/8" Interior Retaining	F04254-1	1	
46	Bearing, R8-2RS Blade Guide	015975 ⁵	2	◆
47	Washer, 5/8" Gray Felt	P06455	1	
48	Spacer, Blade Guide Bearing	035411	1	
	Instruction Sheet, Blade Guide Rebuild	057407-1507	1	
49	Roller, Flanged Blade Guide (Relube 1 1/4" & 1 1/2" blade)	035426	1	◆
	Roller, Flanged Blade Guide (Relube 1 1/2" blade)	057402	1	◆
	Instruction Sheet, Blade Guide Roller Replacement	A04925-364	1	
50	BOLT, BLADE GUIDE ROLLER (RELUBE ONLY)	036161	1	
51	FITTING, 1/4-28 GREASE (RELUBE ONLY)	P05060	1	

¹ Roller/Block Assembly 003925 is no longer available. Use component parts to service or order Roller/Block Assembly 036812 for 1-1/4" blades or 065933 for 1-1/2" blades.

² The sawmill is equipped standard with non-greasable blade guide rollers that can be used with the standard 1 1/2" blade. The roller can also be used with 1 1/4" blades. Optional extended blade guide rollers are available for use with 1 1/2" blades. The extended rollers may provide more stability during difficult sawing, but will reduce the total amount of times the blade can be reused after sharpening. Optional relube versions of each roller configuration are also available.

³ Nord-Lock Washer F05011-125 replaced Split Lock Washer F05011-9 to prevent loosening due to vibration (Rev. B3.01).

⁴ 052309 blocks for use with 1 1/2" blade provided as standard equipment. 052355 blocks available for optional use with 1 1/4" blades. EZ-Glide blocks 036347 are available for customers who prefer this block.

⁵ Bearing must be modified for use with relube roller assemblies. Remove one seal from each bearing, place open sides facing each other and place spacer 035411 between bearings.

2.5 Blade Guide Assembly, Drive Side

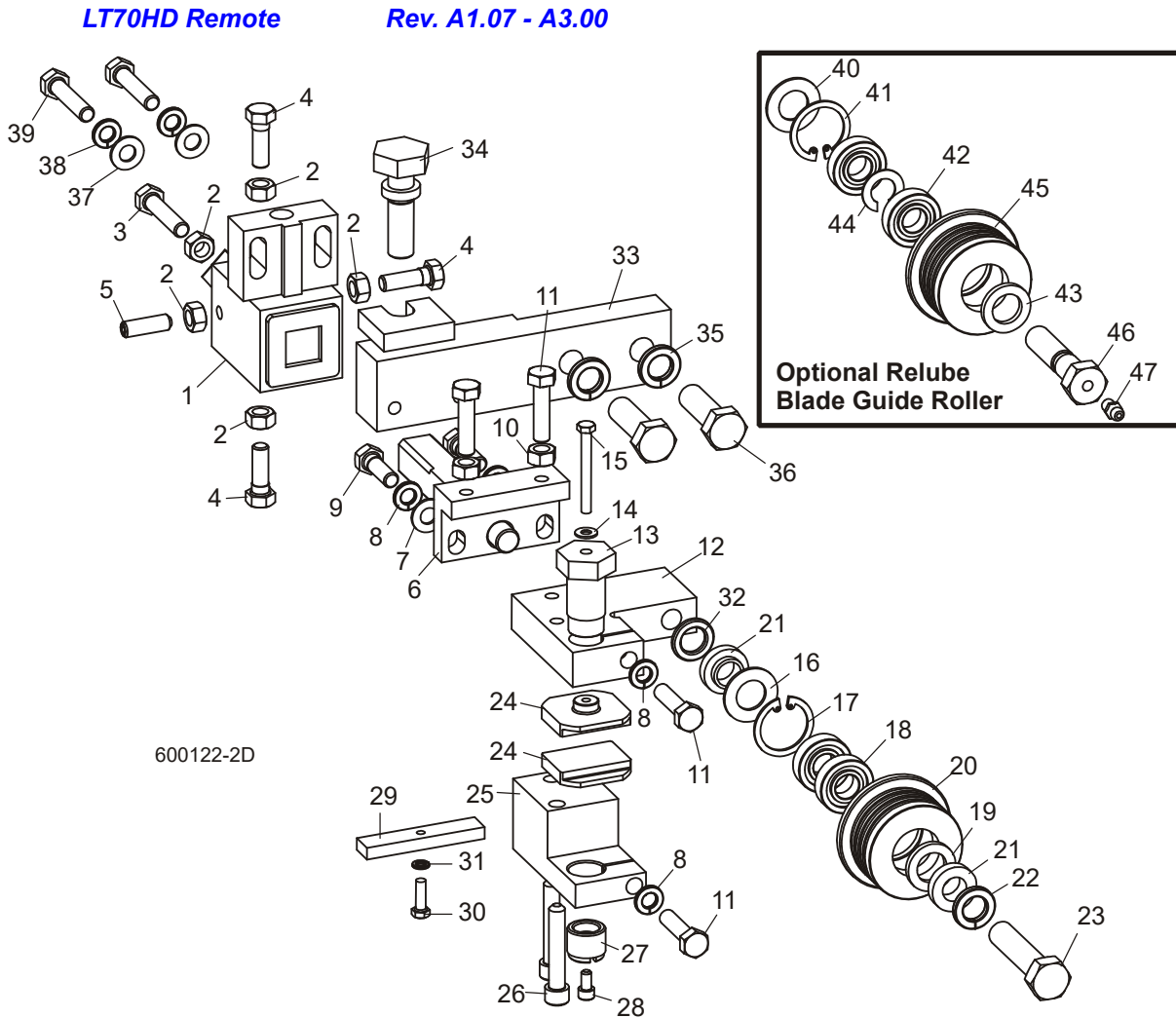

REF	DESCRIPTION (◆ Indicates Parts Available In Assemblies Only)	PART #	QTY.	
	ROLLER/BLOCK ASSEMBLY, DRIVE SIDE (INNER)	044050	1	◆
	Block Assembly, Blade Guide Mount	036100	1	
1	Block Weldment, Blade Guide Mount	035219	1	◆
2	Nut, 5/16-18 Hex	F05010-17	5	
3	Bolt, 5/16-18 x 1 1/2" Hex Head Full Thread Stainless Steel	F05006-119	1	
4	Bolt, 5/16-18 x 1" Hex Head Stainless Steel	F05006-88	3	
5	Screw, 5/16-18 x 1" Socket Head Flat Point Stainless Steel Set	F05006-122	1	
6	Shaft Weldment, Block Guide Pivot	035209	1	
7	Washer, 5/16" SAE Flat	F05011-17	2	
8	Washer, 5/16" Split Lock	F05011-13	4	
9	Bolt, 5/16-18 x 1" Hex Head Stainless Steel	F05006-88	2	

2

Blade Guide Rollers & Arm*Blade Guide Assembly, Drive Side*

10	Nut, 5/16-18 Hex	F05010-17	2	
11	Bolt, 5/16-18 x 1 1/4" Hex Head Stainless Steel	F05006-118	4	
12	Block, Upper Blade Guide	044051	1	
13	Bolt, Blade Guide Block Mount	035216	1	
14	Washer, #10 Brass	042867	1	
15	Bolt, #10-32 x 1 3/4" Hex Head Stainless Steel	F05004-178	1	
	Roller Assembly, Blade Guide (standard for use with 1 1/4" & 1 1/2" blades)	A04925 ²	1	
	Roller Assembly, Extended Blade Guide (optional for use with 1 1/2" blades)	014299 ²	1	
	Bearing Kit, Blade Guide Rebuild	K07079	1	
16	Washer, 5/8" White Felt	P04252	1	
17	Ring, 1 1/8" Interior Retaining	F04254-1	1	
18	Bearing, R8-2RS Blade Guide	015975	2	◆
19	Washer, 5/8" Gray Felt	P06455	1	
	Screw, 1/4-28 x 1/4" Socket Head Cup Point Set Black Oxide	F05005-105	1	
	Instruction Sheet, Blade Guide Rebuild	057407-1507	1	
20	Roller, Flanged Blade Guide (1 1/4" & 1 1/2" blade)	S04250	1	◆
	Roller, Flanged Blade Guide (1 1/2" blade)	014298	1	◆
	Instruction Sheet, Blade Guide Roller Replacement	A04925-364	1	
21	Spacer, Blade Guide	S04253	2	
22	Washer, 1/2" Split Lock	F05011-9 ³	1	
23	Bolt, Blade Guide Roller	036399	1	
24	Block, Blade Guide Wear (Standard for 1 1/2" Blades)	052309 ⁴	2	
	Block, Blade Guide Wear (Optional for 1 1/4" Blades)	052355 ³	2	
	Block Assembly, 1" Sq. EZ-Glide Wear	036347 ³	2	
25	Block, Lower Blade Guide	044052	1	
26	Screw, 5/16-18 x 1 3/4" Socket Head	F05006-65	2	
27	Screw, Lower Block Adjustment	044057	1	
28	Screw, #10-32 x 3/8" Socket Head Stainless Steel	F05004-200	1	
29	Block, Blade Guide Alignment	035799	1	
30	Screw, #10-32 x 5/8" Hex Head	F05004-152	1	
31	Washer, #10 Split Lock	F05011-20	1	
32	Spacer, 1/2" ID x 7/8" OD x 1/8" Thick (For use with 1 1/4" Blades Only)	052364 ⁵	1	
33	ARM WELDMENT, DRIVE SIDE BLADE GUIDE	034292	1	
34	BOLT, BLADE GUIDE VERTICAL ADJUSTMENT	035656	1	
35	WASHER, 1/2" SPLIT LOCK	F05011-9	2	
36	BOLT, 1/2-13 X 1 1/2" HEX HEAD GRADE 5	F05008-33	2	
	SHIM, .008" BLADE GUIDE BLOCK SPACER	035248	1	
37	WASHER, 5/16" SAE FLAT	F05011-17	2	
38	WASHER, 5/16" SPLIT LOCK	F05011-13	2	
39	BOLT, 5/16-18 X 1 1/2" HEX HEAD STAINLESS STEEL	F05006-119	2	

	ROLLER ASSEMBLY, BLADE GUIDE RELUBE (OPTIONAL FOR USE WITH 1 1/4" & 1 1/2" BLADES)	016568 ²	1	
	ROLLER ASSEMBLY, EXTENDED BLADE GUIDE RELUBE (OPTIONAL FOR USE WITH 1 1/2" BLADES)	057405 ²	1	
	Bearing Kit, Relube Blade Guide Rebuild	057407	1	
40	Washer, 5/8" White Felt	P04252	1	
41	Ring, 1 1/8" Interior Retaining	F04254-1	1	
42	Bearing, R8-2RS Blade Guide	015975 ⁶	2	◆
43	Washer, 5/8" Gray Felt	P06455	1	
44	Spacer, Blade Guide Bearing	035411	1	
	Instruction Sheet, Blade Guide Rebuild	057407-1507	1	
45	Roller, Flanged Blade Guide (Relube 1 1/4" & 1 1/2" blade)	035426	1	◆
	Roller, Flanged Blade Guide (Relube 1 1/2" blade)	057402	1	◆
	Instruction Sheet, Blade Guide Roller Replacement	A04925-364	1	
46	BOLT, BLADE GUIDE ROLLER (RELUBE ONLY)	036161	1	
47	FITTING, 1/4-28 GREASE (RELUBE ONLY)	P05060	1	

² The sawmill is equipped standard with non-greasable blade guide rollers that can be used with the standard 1 1/2" blade. The roller can also be used with 1 1/4" blades (requires spacer 052364). Optional extended blade guide rollers are available for use with 1 1/2" blades. The extended rollers may provide more stability during difficult sawing, but will reduce the total amount of times the blade can be reused after sharpening. Optional relube versions of each roller configuration are also available.

³ Nord-Lock Washer F05011-125 available to replace Split Lock Washer F05011-9 to prevent loosening due to vibration (12/09).

⁴ Blade guide wear blocks 052309 & 052355 replace EZ-Glide block 036347 originally supplied to improve wear life. 052309 blocks for use with 1 1/2" blade provided as standard equipment. 052355 blocks available for optional use with 1 1/4" blades. EZ-Glide blocks 036347 are available for customers who prefer this block. EZ-Glide pad assembly 036347 replaced Wear Pad assembly 042860 supplied prior to Rev. A3.00. New pad is cost effective and contributes to longer blade life.

⁵ 1/8" thick spacer 052364 replaces 1/4" spacer 041626 to provide proper spacing of blade guide block when using 1 1/4" blades.

⁶ Bearing must be modified for use with relube roller assemblies. Remove one seal from each bearing, place open sides facing each other and place spacer 035411 between bearings.

2 Blade Guide Rollers & Arm

Blade Guide Assembly, Drive Side

2.6 Blade Guide Assembly, Drive Side

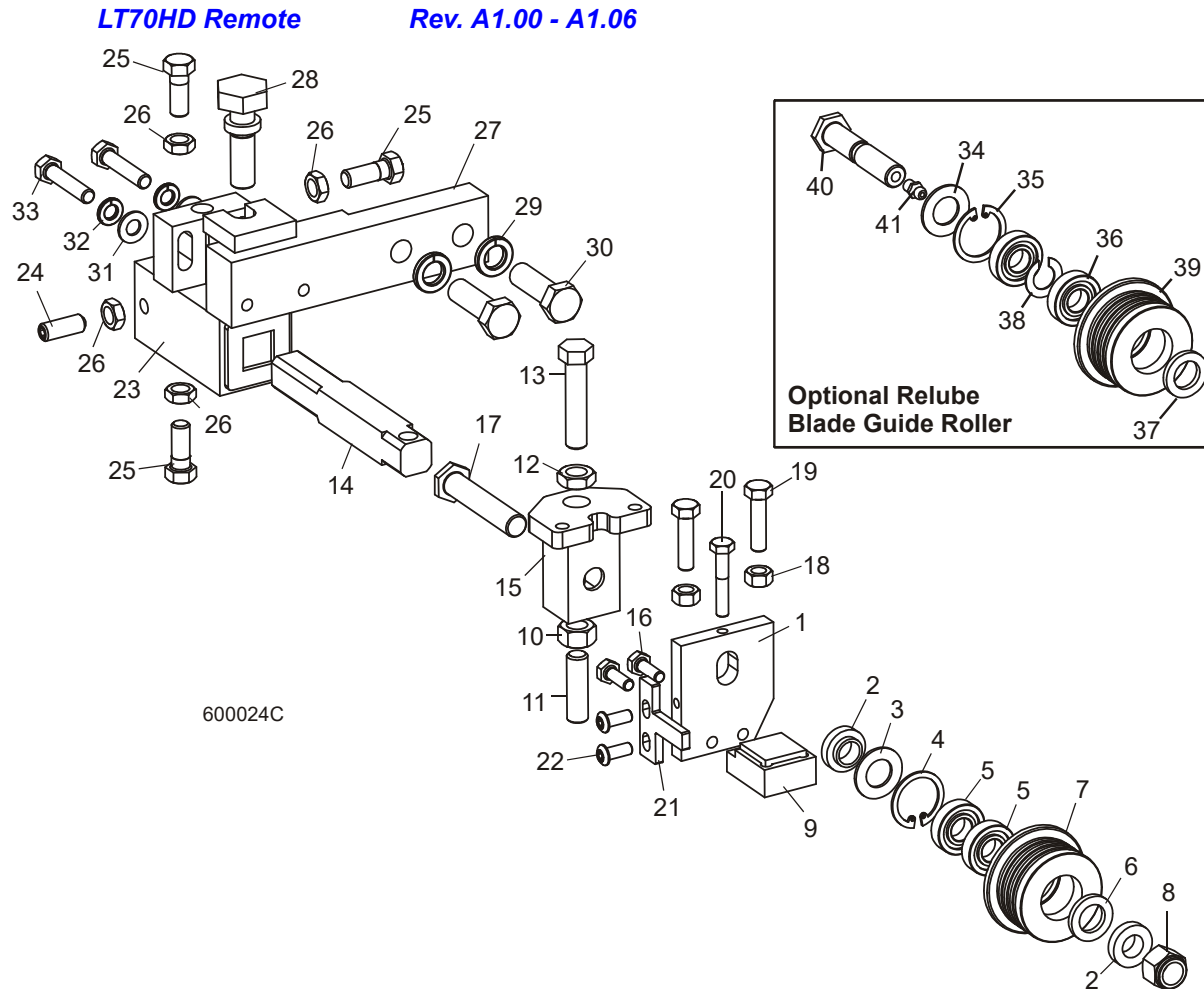

REF	DESCRIPTION (◆ Indicates Parts Available In Assemblies Only)	PART #	QTY.	
	ROLLER/BLOCK ASSEMBLY, DRIVE SIDE (INNER)	044046 ¹	1	◆
1	Plate, Blade Guide Back Mounting	035409	1	
2	Spacer, .510 x .937 x .34	S04253	2	
	Roller Assembly, Blade Guide (standard for use with 1 1/4" or 1 1/2" blades)	A04925 ²	1	
	Roller Assembly, Blade Guide (optional for use with 1 1/2" blades)	014299 ²	1	
	Bearing Kit, Blade Guide Rebuild	K07079	1	
3	Washer, 5/8" White Felt	P04252	1	
4	Ring, 1 1/8" Interior Retaining	F04254-1	1	
5	Bearing, R8-2RS Blade Guide	015975	2	◆
6	Washer, 5/8" Gray Felt	P06455	1	
	Screw, 1/4-28 x 1/4" Socket Head Cup Point Set Black Oxide	F05005-105	1	
	Instruction Sheet, Blade Guide Rebuild	057407-1507	1	

Blade Guide Rollers & Arm

Blade Guide Assembly, Drive Side

2

7	Roller, Flanged Blade Guide (1 1/4" & 1 1/2" blade)	S04250	1	◆
	Roller, Flanged Blade Guide (1 1/2" blade)	014298	1	◆
	Instruction Sheet, Blade Guide Roller Replacement	A04925-364	1	
8	Nut, 1/2-20 Nylon Hex Lock	F05010-15	1	
9	Block Assembly, 1 1/4" Blade EZ-Glide Wear	036247 ³	1	
	Block, 1 1/4" Blade Guide Wear	052367 ³	1	
	Block, 1 1/2" Blade Guide Wear	052366 ³	1	
	Shaft Kit, Blade Guide Adjust Retrofit	038972 ⁴	1	
10	Nut, 7/16-20 Hex	F05010-202 ⁵	1	
11	Screw, 7/16-20 x 1 1/2" Socket Head Cup Point Stainless Steel	F05007-217 ⁶	1	
12	Nut, 7-16-20 Hex Jam	F05010-38	1	
13	Bolt, 7/16-20 x 2" Hex Head Full Thread Grade 8	F05007-215	1	
14	Shaft, Blade Guide Mount	038970	1	
15	Block Weldment, Roller Guide Adjuster	054969	1	
16	Bolt, 1/4-20 x 3/4" Hex Head Grade 5	F05005-123	2	
17	Bolt, Blade Guide Roller	036374	1	
18	Nut, 5/16-24 Hex	F05010-28	2	
19	Bolt, 5/16-24 x 1 1/4" Hex Head Full Thread Stainless	F05006-107	2	
20	Bolt, 1/4-28 x 1 1/2" Hex Head Stainless	F05005-143	1	
21	Guard, Drive Roller	035490	1	
22	Screw, 1/4-20 x 55/8" Button Head Socket Cap Grade 2	F05005-128	2	
23	Block Weldment, Blade Guide Mount	044044	1	
24	Screw, 3/8-24 x 1" Socket Head Flat Point Stainless Steel Set	F05007-184 ⁷	1	
25	Bolt, 3/8-24 x 1" Hex Head Stainless Steel	F05007-99 ⁷	3	
26	Nut, 3/8-24 UNC Hex Jam	F05010-22	4	
	SHIM, .008" BLADE GUIDE BLOCK SPACER	035248	1	
27	ARM WELDMENT, DRIVE SIDE BLADE GUIDE	034292	1	
28	BOLT, BLADE GUIDE VERTICAL ADJUSTMENT	035656	1	
29	WASHER, 1/2" SPLIT LOCK	F05011-9	2	
30	BOLT, 1/2-13 X 1 1/2" HEX HEAD GRADE 5	F05008-33	2	
31	WASHER, 5/16" SAE FLAT	F05011-17	2	
32	WASHER, 5/16" SPLIT LOCK	F05011-13	2	
33	BOLT, 5/16-18 X 1 1/2" HEX HEAD FULL THREAD GRADE 5	F05006-76 ⁸	2	
	ROLLER ASSEMBLY, BLADE GUIDE RELUBE (OPTIONAL FOR USE WITH 1 1/4" & 1 1/2" BLADES)	016568 ²	1	
	ROLLER ASSEMBLY, EXTENDED BLADE GUIDE RELUBE (OPTIONAL FOR USE WITH 1 1/2" BLADES)	057405 ²	1	
	Bearing Kit, Relube Blade Guide Rebuild	057407	1	
34	Washer, 5/8" White Felt	P04252	1	
35	Ring, 1 1/8" Interior Retaining	F04254-1	1	
36	Bearing, R8-2RS Blade Guide	015975 ⁹	2	◆
37	Washer, 5/8" Gray Felt	P06455	1	

2

Blade Guide Rollers & Arm

Blade Guide Assembly, Drive Side

38	Spacer, Blade Guide Bearing	035411	1	
	Instruction Sheet, Blade Guide Rebuild	057407-1507	1	
39	Roller, Flanged Blade Guide (Relube 1 1/4" & 1 1/2" blade)	035426	1	◆
	Roller, Flanged Blade Guide (Relube 1 1/2" blade)	057402	1	◆
	Instruction Sheet, Blade Guide Roller Replacement	A04925-364	1	
40	BOLT, BLADE GUIDE ROLLER (RELUBE ONLY)	035412	1	
41	FITTING, 1/4-28 GREASE (RELUBE ONLY)	P05060	1	

¹ 044046 Blade Guide Assembly replaced with 036812 12/05 then 003925 1/08 and no longer available. Use component parts to service or replace entire assembly with 003925. New assembly provides easier adjustment ([See Section 2.4](#)). Blade Guide Assembly 044046 upgraded with new Block Weldment and Shaft to accommodate 7/16" adjustment hardware to improve durability (12/06). Use kit 038972 to retrofit previous revisions.

² The sawmill is equipped standard with non-greasable blade guide rollers that can be used with the standard 1 1/2" blade. The roller can also be used with 1 1/4" blades (requires spacer 052364). Optional extended blade guide rollers are available for use with 1 1/2" blades. The extended rollers may provide more stability during difficult sawing, but will reduce the total amount of times the blade can be reused after sharpening. Optional relube versions of each roller configuration are also available.

³ Wear Block 052367 available 10/07 and provided as standard 4/09. Use to replace ceramic guide block 035222, screw F05004-71 & mount block 035235 originally supplied. EZ-Glide Block 036247 available for customers who prefer this block. Wear Block 052366 available for optional use with 1 1/2" blades.

⁴ Mount Shaft 044047, Adjuster Block 035408, 3/8" Set Screws F05007-162 & 3/8" Jam Nuts F05010-22 replaced with 7/16" adjustment hardware. Mount Shaft 044047 & Adjuster Block 035408 no longer available. Use kit 038972 to retrofit original parts.

⁵ Lower jam nut F05010-38 replaced with hex nut F05010-202 (3/07).

⁶ Stainless Set Screw replaces Zinc plated screw F05007-213 used prior to 6/07 to eliminate screw shearing.

⁷ Replaces four F05007-96 originally supplied prior to Rev. A1.02.

⁸ Replaces two F05006-119 originally supplied prior to Rev. A1.02.

⁹ Bearing must be modified for use with relube roller assemblies. Remove one seal from each bearing, place open sides facing each other and place spacer 035411 between bearings.

2.7 Blade Guide Arm Drive Assembly

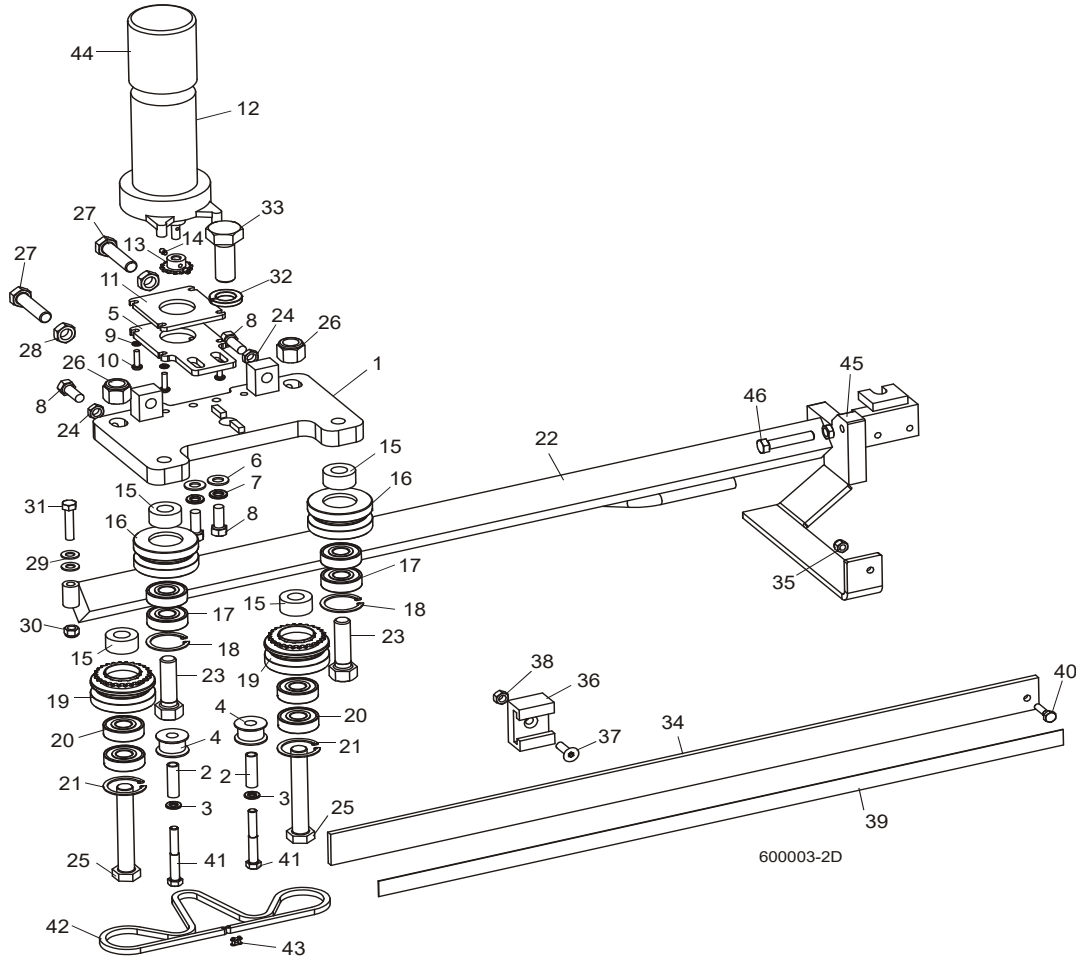

REF	DESCRIPTION (◆ Indicates Parts Available In Assemblies Only)	PART #	QTY.
	ARM ASSEMBLY, IDLE SIDE BLADE GUIDE	034290	1
1	Plate Weldment, Blade Guide Arm	034286	1
2	Spacer, .322" x .44" x 1 1/2"	S09996	2
3	Washer, 5/16" Split Lock	F05011-13	2
4	Roller, Blade Guide Drive	S09999	2
5	Plate, Blade Guide Motor Mount	033803	1
6	Washer, 3/8" SAE Flat	F05011-3	2
7	Washer, 3/8" Split Lock	F05011-4	2
8	Bolt, 3/8-16 x 1" Hex Head	F05007-7	4
9	Washer, #10 Split Lock	F05011-20	4
10	Screw, #10-32 x 3/4" Phillips Head Machine	F05004-38	4
11	Plate, Blade Guide Motor Mount Spacer	033805	1
12	Motor, 1/30 HP 62RPM 12VDC 53:1 Gear	P09698-1	1
	Housing, Klauber Motor End	P12756	1

2

Blade Guide Rollers & Arm Blade Guide Arm Drive Assembly

	Gear Kit, Klauber Motor Replacement	P12569	1	
	Brush Kit, Gear Motor Replacement	P12800	1	
	Shaft Kit, Klauber Gear Motor Replacement	009695	1	
13	Sprocket Assembly, 25B14 x .3130	036664 ¹	1	
14	Screw, #10-24 x 1/4" Full Dog Point Socket Set	F05004-274	2	
15	Spacer, Blade Guide Arm V-Roller	033913	4	
	Roller Assembly, Blade Guide Arm V Idle	042543	2	
16	Housing, 2 1/2" V-Groove	042536	1	
17	Bearing, 5/8" x 1.7548" x .4724"	P06030-1	2	
18	Ring, 1.575" ID Beveled 5002-156 Retaining	F04254-8	1	
	Roller Assembly, Blade Guide Arm V Drive	042542	2	
19	Housing, 2 1/2" V-Groove w/Sprocket	042541	1	
20	Bearing, 5/8" x 1.7548" x .4724"	P06030-1	2	
21	Ring, 1.575" ID Beveled 5002-156 Retaining	F04254-8	1	
22	Arm Weldment, Blade Guide	034289	1	
23	Bolt, 5/8-18 x 2 1/4" Hex Head Grade 5	F05009-80	2	
24	Nut, 3/8-16 Hex Jam	F05010-29	2	
25	Bolt, 5/8-18 x 3 1/4" Hex Head Grade 5	F05009-98	2	
26	Nut, 5/8-18 Hex Nylon Lock	F05010-71	2	
27	Bolt, 1/2-20 x 2" Hex Head Full Thread	F05008-126	2	
28	Nut, 1/2-20 Hex Jam	F05010-16	2	
29	Washer, 5/16" SAE Flat	F05011-17	2	
30	Nut, 5/16-18 Hex Nylon Lock	F05010-58	1	
31	Bolt, 5/16-18 x 1 1/2" Hex Head Grade 5	F05008-96	1	
32	Washer, 3/4" Split Lock	F05011-6	1	
33	Bolt, 3/4-16 x 2" Full Thread Hex Head	F05013-1	1	
34	Guard, Blade Guide Arm	014955	1	
35	Nut, 1/4-20 Hex Nylon Lock	F05010-69	1	
36	Bracket, Blade Guide Arm Guide	014882	1	
37	Bolt, 5/16-18 x 3/4" Flat Head Socket	F05006-95	1	
38	Nut, 5/16-18 Hex Lock	F05010-6	1	
39	Decal, Blade Guide Arm Warning Stripe	015849	1	
40	Screw, 1/4-20 x 1" Hex Head	F05005-38	1	
41	Bolt, 5/16-18 x 2 1/2" Hex Head Grade 5	F05006-80	2	
42	Chain, #25 x 27 3/4"	036194 ²	1	
43	Link, #25 Master	P09983	2	
44	Cap, 2.5" ID x 3" Rubber	023720 ³	1	
45	Nut, 3/8-16 Hex Jam	F05010-29	1	
46	Bolt, 3/8-16 x 2" Hex Head Full Thread	F05007-16	1	

¹ Sprocket modified 6/11 with threaded holes to accept included set screws (replace 1/8" x 3/4" roll pin F05012-6). 14 Tooth Sprocket 036664 replaces 13 Tooth Sprocket P09970 to improve speed of blade guide arm operation (11/04).

² Purchased chain 036194 replaces manufactured chain 042443 supplied prior to Rev. A2.00

³ 023720 Rubber Cap added Rev. A1.02

SECTION 3 BLADE WHEELS & TENSIONER

3.1 Blade Drive Assembly

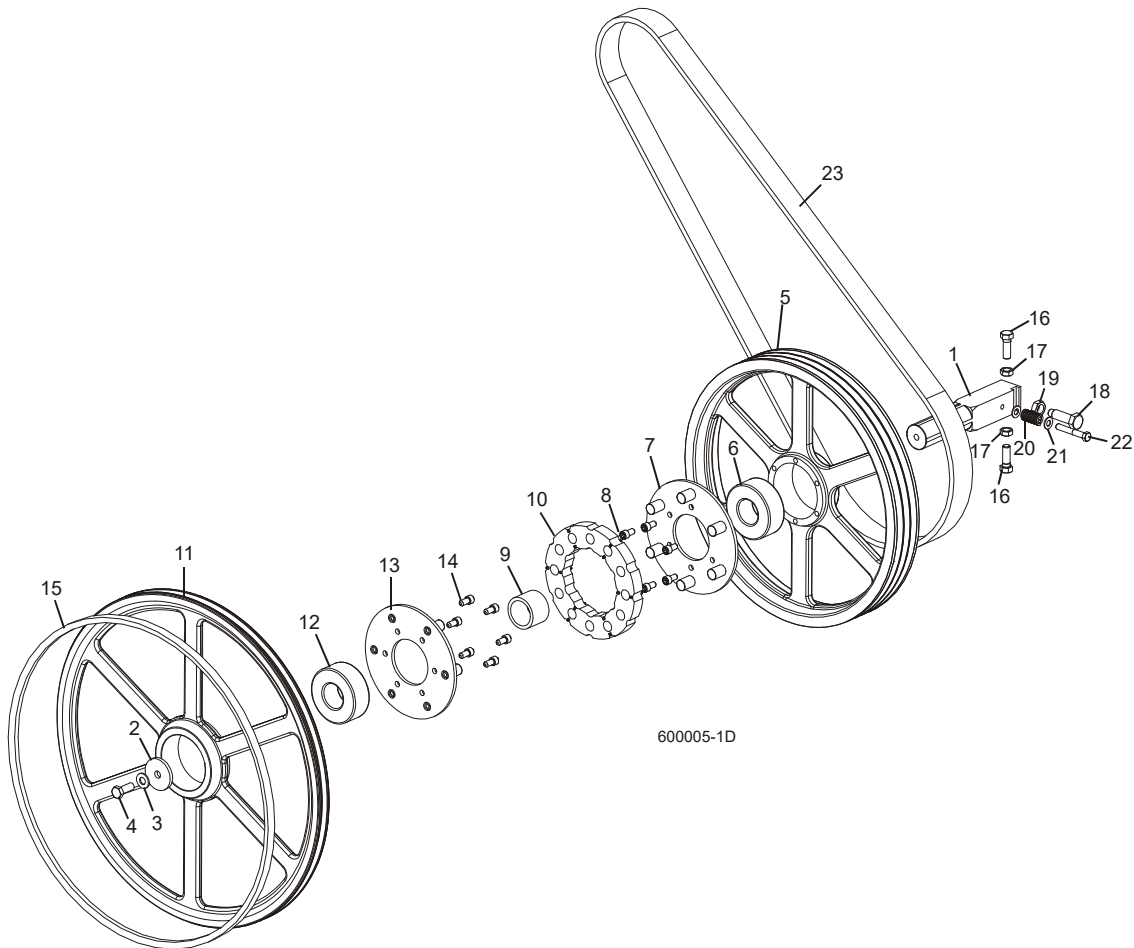

REF	DESCRIPTION (◆ Indicates Parts Available In Assemblies Only)	PART #	QTY.
	WHEEL ASSEMBLY, BLADE DRIVE	034359	1
1	Shaft, Blade Drive Wheel	033920	1
2	Washer, Blade Drive Wheel	033909	1
3	Washer, 1/2" SAE Flat	F05011-2 ¹	1
4	Bolt, 1/2-13 x 1 1/4" Hex Head Grade 5	F05008-37	1
	Pulley Assembly, 19" Blade Drive	034426	1
5	Pulley, Blade Drive	033809	1
6	Bearing, 5309-2RS	016014	1
7	Plate Assembly, Coupling	034424	1
8	Bolt, 3/8-24 x 3/4" Socket Head	F05007-154	6
9	Spacer, Drive Bearing	033921	1

3

Blade Wheel & Tensioner

Blade Drive Assembly

10	Ring, Drive Coupling	034418	1	
	Wheel Assembly, 24" Blade	017834	1	
11	Wheel, 24" Blade	034872	1	
12	Bearing, 5309-2RS	016014	1	
13	Plate Assembly, Coupling	034424	1	
14	Bolt, 3/8-24 x 3/4" Socket Head	F05007-154	6	
15	BELT, B72.5 BLADE WHEEL	017922-1 ²	1	
16	BOLT, 1/2-20 X 1 1/2" HEX HEAD GRADE 5	F05008-53	2	
17	NUT, 1/2-20 HEX JAM	F05010-16	2	
18	BOLT, DRIVE WHEEL RETAINING	034360	1	
19	NUT, 5/8-18 HEX JAM	F05010-11	1	
20	SPRING, 3/4" OD X 1 1/2" LONG DIE	034430	1	
21	WASHER, 3/8" SAE FLAT	F05011-3	2	
22	BOLT, 3/8-16 X 2 1/2" HEX HEAD GRADE 5	F05007-125	1	
23	BELT, 3/5VFX950 DRIVE	045190	1	

¹ Replaces 1/2" Split Lock Washer F05011-9 (Rev. A1.06). Lock washer deformed with proper torque. Use Loc-Tite to secure bolt.

² 017922-1 B72.5 Belt replaces 017922 supplied prior to 7/10. New belt provides longer service life.

3.2 Idle Blade Wheel Assembly

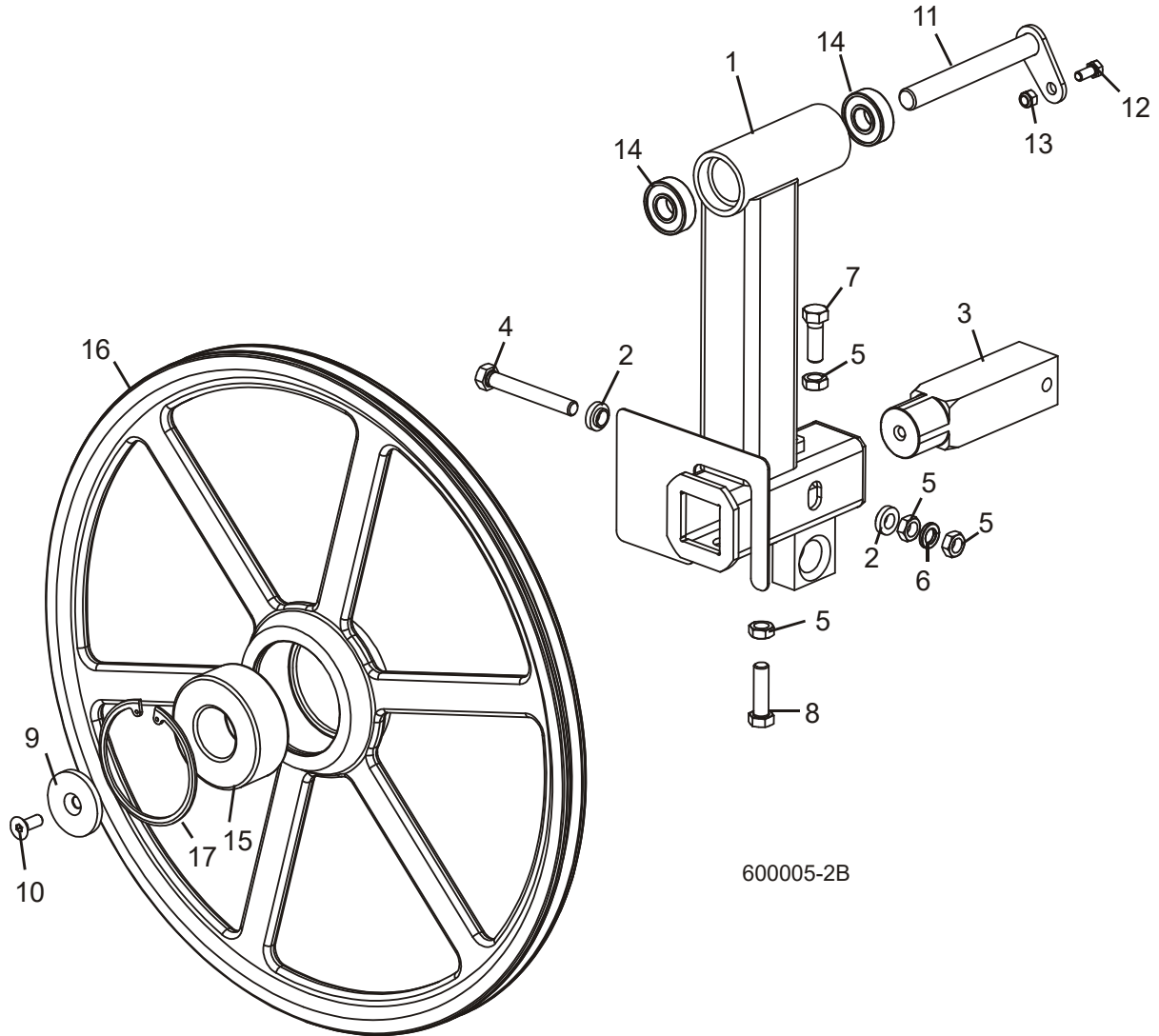

REF	DESCRIPTION (◆ Indicates Parts Available In Assemblies Only)	PART #	QTY.
	SHAFT ASSEMBLY, IDLE BLADE WHEEL	034356	1
1	Tube Weldment, Idle Side Blade Wheel	034296	1
2	Spacer, .510" x .937" x .34"	S04253	2
3	Shaft, Idle Side Blade Wheel	017706	1
4	Bolt, 1/2-20 x 3 3/4" Hex Head Full Thread Grade 5	F05008-111	1
5	Nut, 1/2-20 Hex Jam	F05010-16	4
6	Washer, 1/2" Split Lock	F05011-9	1
7	Bolt, 1/2-20 x 1 1/2" Hex Head Grade 5	F05008-53	1
8	Bolt, 1/2-20 x 1 3/4" Hex Head Full Thread	F05008-127	1
9	Washer, 3/32" ID x 2 1/4" OD x 1/4" Thick	016397	1

3

Blade Wheels & Tensioner

Idle Blade Wheel Assembly

10	Bolt, 3/8-16 x 1" Flat Socket Head	F05007-64	1	
11	Pin Weldment, Idle Wheel Pivot	034358	1	
12	Bolt, 5/16-18 x 3/4" Hex Head	F05006-102	1	
13	Nut, 5/16-18 Hex Nylon Lock	F05010-58	1	
14	Bearing, #465966	034470	2	
	WHEEL ASSEMBLY, 24" IDLE BLADE	017835	1	
15	Bearing, 5309-2RS	016014	1	
16	Wheel, 24" Blade	034871	1	
17	Ring, 100 mm Beveled Inside Retaining	F04254-28	1	
	BELT, B72.5 BLADE WHEEL (NOT SHOWN)	017922-1 ¹	1	

¹ 017922-1 B72.5 Belt replaces 017922 supplied prior to 7/10. New belt provides longer service life.

3.3 Hydraulic Blade Tensioner Assembly

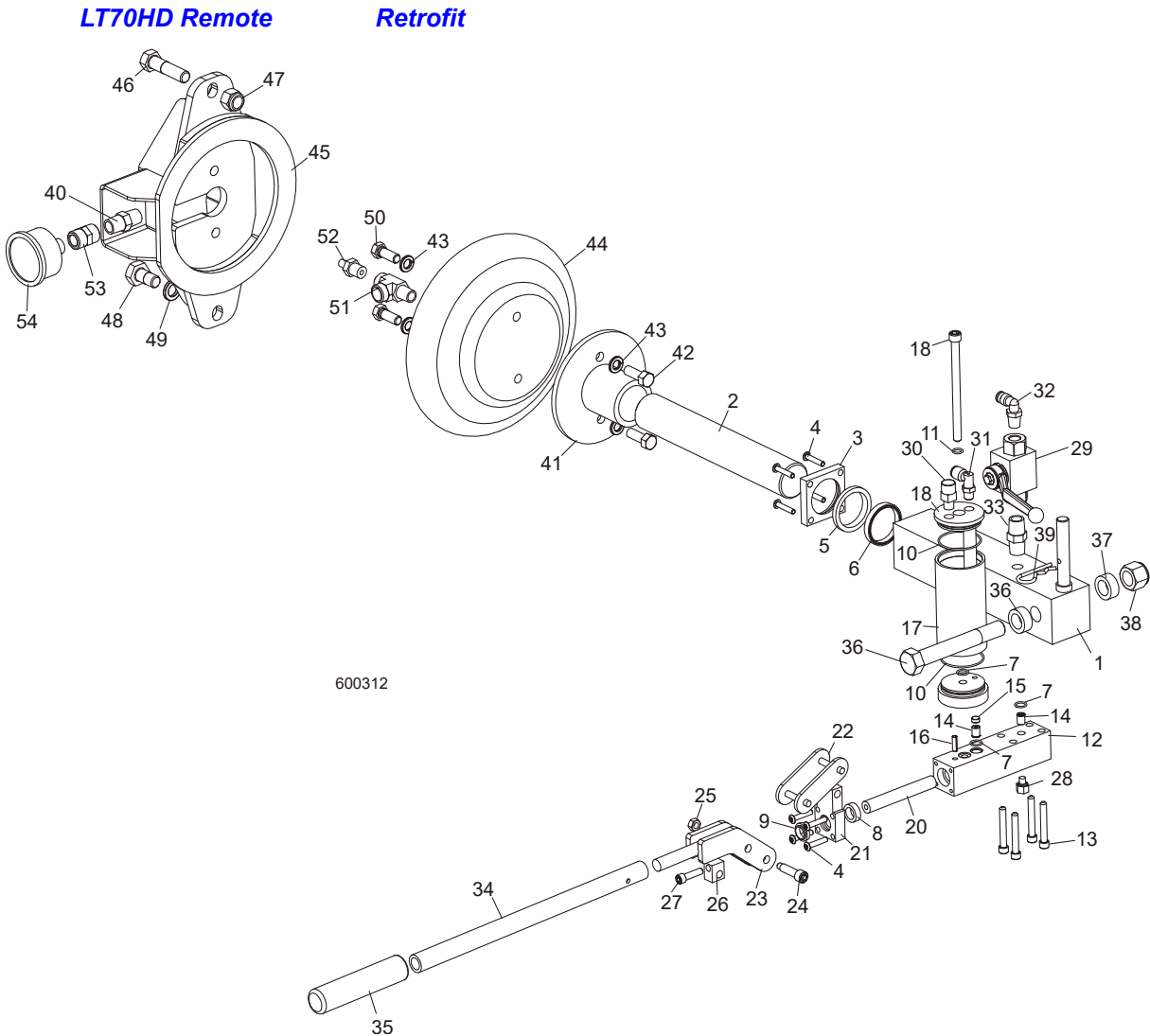

REF	DESCRIPTION (◆ Indicates Parts Available In Assemblies Only)	PART #	QTY.	
1-54	TENSIONER ASSEMBLY, LT70 HYDRAULIC BLADE	054844 ¹	1	◆
1-33	Block Kit, Hydraulic Tensioner Service	006529 ¹	1	
1-28	Block Assembly, Hydraulic Blade Tensioner	055315	1	◆
1	Block Weldment, Tensioner Cylinder	056809	1	
2	Rod, Tensioner Push	054848	1	
3	Block, Tensioner Push Rod Wiper	054846	1	
4	Screw, #10-24 x 1" Socket Button Head	F05004-43	8	
5-11	Seal Kit, Hydraulic Tensioner Service	006528	1	
5	Wiper, 1 1/2" Rod	056884	1	◆

3

Blade Wheels & Tensioner Hydraulic Blade Tensioner Assembly

6	Seal, 1 1/2" Loaded Lip	056887	1	◆
7	O-Ring, 1/16" x 3/8" ID x 1/2" OD	056888	3	◆
8	Seal, 1/2" Loaded Lip	056886	1	◆
9	Wiper, 1/2" Rod	056885	1	◆
10	O-Ring, 1/16" x 1 5/8" ID x 1 3/4" OD	056889	2	◆
11	O-Ring, 5/16" ID x 7/16" OD #011	033477	1	◆
	Inst. Sheet, LT70 Hydraulic Blade Tensioner Seal Replacement	006825-1601	1	
12	Block, Tensioner Piston	054845	1	
13	Screw, 1/4-20 x 1 3/4" Socket Head	F05005-156	4	
14	Valve, 8mm Check	056883	2	
15	Screen, Hydraulic Cartridge	006274	1	
16	Pin, 3/16" x 5/8" Roll	F05012-22	1	
17	Tube, Hydraulic Fluid Tank	054837	1	
18	Cap Weldment, Hydraulic Reservoir	006366	1	
19	Screw, 5/16-18 x 4 1/2" Socket Head	F05006-135	1	
20	Rod, Tensioner Piston	054842	1	
21	Block, Tensioner Pivot Link	054843	1	
22	Link, C2080H Master	016796	1	
23	Link Weldment, Tensioner Pivot	055316	1	
24	Screw, 5/16" x 1" (1/4-20 Thread) Socket Head Shoulder	F05006-41	1	
25	Nut, 1/4-20 Hex Lock	F05010-21	1	
26	Block, Piston Link	054840	1	
27	Screw, 1/4-20 x 1" Socket Head	F05005-89	1	
28	Plug, 5/16-24 x 5/8" O-Ring	P10065	1	
29	Valve, 7250 PSI Hydraulic	056806	1	
30	Fitting, 1/8" NPT Protected Vent	056890	1	
31	Fitting, 1/4" NPT x 1/4" Tube 90° Elbow	P21519	1	
32	Fitting, 1/8" MPT x 1/4" Tube Swivel Elbow	P09736	1	
33	Fitting, 1/4" NPT Hex Nipple	P21524	1	
34	Tube, Tensioner Handle	055318	1	
35	Grip, 3/4" ID x 4 1/2" Handle	049031	1	
36	Bolt, 5/8-11 x 4 1/2" Hex Head Grade 5	F05009-10	1	
37	Spacer, 5/8" ID x 1" OD x 13/32"	056900	2	
38	Nut, 5/8-11 Hex Nylon Lock	F05010-34	1	
39	Pin, 1/8" x 1 13/16" Safety	P05059	1	
40	Fitting, 1/4" NPT Hex Nipple	P21524	1	
41	Tube Weldment, Tensioner	055317	1	
42	Bolt, 3/8-16 x 1" Hex Head	F05007-7	2	
43	Washer, 3/8" Split Lock	F05011-4	4	
44	Bag, Blade Tensioner Air	033984	1	
45	Plate Weldment, Air Bag Mount	034276	1	
46	Bolt, 1/2-13 x 2" Hex Head	F05008-76	1	
47	Nut, 1/2-13 Hex Nylon Lock	F05010-8	1	

Blade Wheels & Tensioner
Hydraulic Blade Tensioner Assembly

3

48	Bolt, 1/2-13 x 1" Hex Head	F05008-50	1	
49	Washer, 1/2" Split Lock	F05011-9	1	
50	Bolt, 3/8-16 x 1" Hex Head Grade 5	F05007-87	2	
51	Fitting, 1/4" NPT x 1/4" JIC Male Run Tee	P09141	1	
52	Fitting, 1/4" NPT Air Valve	034285	1	
53	Fitting, 1/4" NPT Coupling	P03420	1	
54	Gauge, Liquid-Filled Air	034278	1	

¹ Tensioner Assembly 054844 modified Rev. B4.08. 006529 Hydraulic Tensioner Service Block Kit no longer available. Use 065538 Blade Tensioner Retrofit Kit including hydraulic pump, pump mount, hydraulic cylinder and additional hardware to retrofit blade tensioner.

3 Blade Wheels & Tensioner

Blade Tensioner Assembly

3.4 Blade Tensioner Assembly

LT70HD Remote

Rev. A1.00 - A3.00

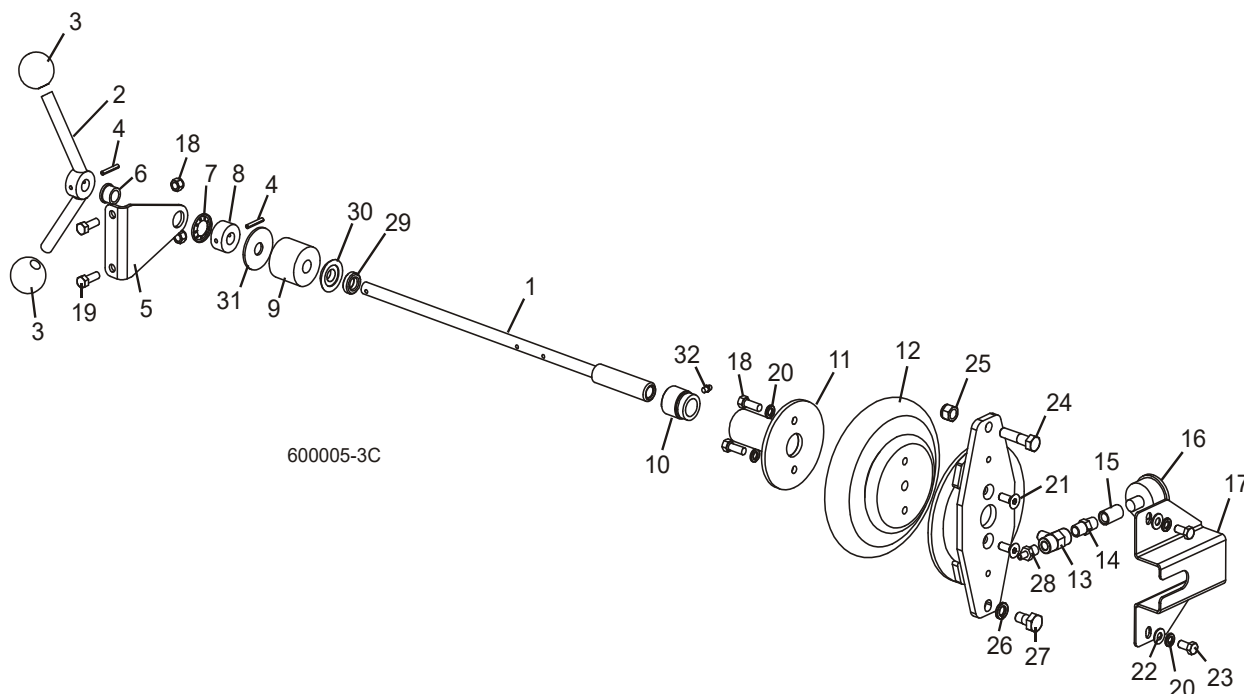

REF	DESCRIPTION (◆ Indicates Parts Available In Assemblies Only)	PART #	QTY.
	TENSIONER ASSEMBLY, LT70 BLADE	034272 ¹	1
1	Shaft Weldment, Blade Tensioner	014846 ¹	1
2	Handle Weldment, Blade Tensioner	034271	1
3	Knob, 5/8-11 Ball	P04211	2
4	Pin, 3/16" x 1 1/4" Roll	F05012-16	2
5	Plate, Tensioner Handle Support	033810	1
6	Bushing, 5/8" ID x 7/8" OD x 1/2" Long Bronze	P05135	1
7	Washer, 7/8" Push Nut 5115-87	F04254-31	1
8	Hub, Tensioner Handle	014921	1
9	Bushing, 11/16" x 2 1/8" x 1 3/4" Rubber	P12165	1
10	Nut, 1-10 LH Stepped Acme	017707 ¹	1
11	Tube Weldment, Tensioner Nut	034275	1
12	Bag, W01-358-7564 Air	033984	1
13	Fitting, 1/4" NPT Tee	015486 ¹	1
14	Nipple, 1/4" NPT Hex	P21524	1
15	Coupling, 1/4" NPT Steel	P03420 ²	1
16	Gauge, Liquid Filled Air	034278	1
17	Guard, Air Gauge	034245	1
18	Nut, 3/8-16 Hex Nylon Lock	F05010-10	2

Blade Wheels & Tensioner

Blade Tensioner Assembly

3

19	Bolt, 3/8-16 x 1" Hex Head	F05007-7	4	
20	Washer, 3/8" Split Lock	F05011-4	4	
21	Bolt, 3/8-16 x 1" Flat Socket Head	F05007-64	2	
22	Washer, 3/8" SAE Flat	F05011-3	2	
23	Bolt, 3/8-16 x 3/4" Hex Head	F05007-27	2	
24	Bolt, 1/2-13 x 2" Hex Head	F05008-76	1	
25	Nut, 1/2-13 Hex Nylon Lock	F05010-8	1	
26	Washer, 1/2" Split Lock	F05011-9	1	
27	Bolt, 1/2-13 x 1" Hex Head	F05008-50	1	
28	Fitting, 1/4" NPT Air Tank Valve	034285	1	
29	Bearing, 5/8" Thrust	P04214	1	
30	Pivot, Tension Thrust Bearing	034502	1	
31	Washer, .66 x 2.25 x 11Ga	017711	1	
32	Fitting, 1/4-28 Grease	P05060 ¹	1	

¹ Blade Tensioner 034272 no longer available. Use kit 065696 to upgrade to Hydraulic Blade Tensioner ([See Section 3.3](#)). Tensioner Assembly 034272 modified Rev. A1.02. 014846 Shaft Weldment replaced 033937. 017707 Threaded Nut replaced 034273 and Grease Fitting P05060 added. 015486 1/4" NPT Tee Fitting replaced 034284.

² Replaces 042254 originally supplied prior to 2/03 (duplicate parts).

4 Saw Head
Middle Throat Screw

SECTION 4 SAW HEAD

4.1 Middle Throat Screw

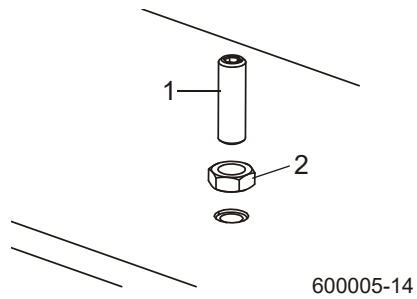

REF	DESCRIPTION (◆ Indicates Parts Available In Assemblies Only)	PART #	QTY.	
1	SCREW, 3/8-16 X 1 1/2" OVAL POINT SOCKET SET	F05007-190 ¹	1	
2	NUT, 3/8-16 HEX JAM	F05010-29	1	

¹ Replaces 1 1/4" Screw F05007-18 supplied prior to Rev. A2.00. Longer screw provides more adjustment.

4.2 Belt Tensioner

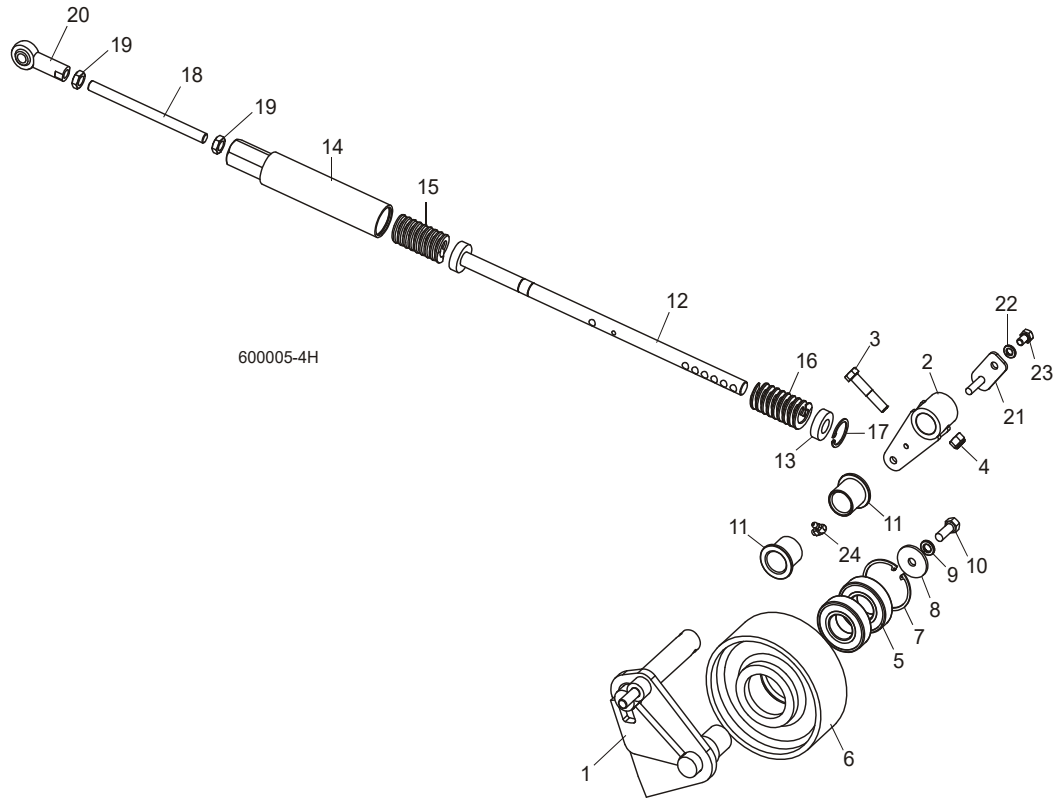

REF	DESCRIPTION (◆ Indicates Parts Available In Assemblies Only)	PART #	QTY.
	TENSIONER ASSEMBLY, DRIVE BELT	034894	1
	Pivot Kit, Drive Belt Tensioner Retrofit	038934 ¹	1
1	Arm Weldment, Drive Belt Tensioner	034893 ²	1
2	Pivot Weldment, Drive Belt Tensioner	034593	1
	Instruction Sheet, Tensioner Pivot Retrofit	038934-1265	1
3	Bolt, 3/8-16 x 2" Hex Head Grade 5	F05007-124	1
4	Nut, 3/8-16 Hex Nylon Lock	F05010-10	1
5	Bearing, 6206 25" Idler	P11035	2
6	Idler, Drive Belt	033941	1
7	Ring, 62mm Inside Retaining	F04254-12	1
8	Washer, 3/8" x 1 1/2" x 1/8"	F05011-104 ³	1
9	Washer, 3/8" Split Lock	F05011-4	1
10	Bolt, 3/8-16 x 1" Hex Head	F05007-7	1
11	Bushing, 1" ID x 1 1/4" OD Flanged	P109	2
	Rod Kit, Drive Belt Tensioner	003193 ⁴	1
12	Rod Weldment, Drive Belt Tensioner	017923 ⁵	1
13	Washer, Tensioner	034674	1

4

Saw Head

Belt Tensioner

14	Tube Weldment, Drive Belt Tensioner	034689	1	
	Spring Kit, Belt Tensioner Retrofit	036501 ⁶	1	
15	Spring, 1 1/4" OD x 2 1/2" Die, Heavy	036136 ⁶	2	
	Instruction Sheet, Belt Tensioner Spring Retro	036501-1148	1	
16	Ring, 1 15/16" Inside Retaining	F04254-44	1	
17	Rod, 7/16-20 x 6" Threaded	017924	1	
18	Nut, 7/16-20 Hex Jam	F05010-38	2	
19	Rod End, 7/16-20 Right Hand Female	017925	1	
20	Pin Weldment, Drive Belt Tensioner	034673	1	
21	Washer, 5/16" Split Lock	F05011-13	1	
22	Bolt, 5/16-18 x 1/2" Hex Head Grade 5	F05006-15	1	

¹ Retrofit 038934 for Revs. prior to 9/06. Arm Weldment 034893 and Pivot Weldment 034593 modified to increase range of motion to reduce strain on gearbox.

² Gussets added to arm to improve durability (Rev. 8/04).

³ Washer F05011-104 replaces 021276 (Rev. A1.06).

⁴ Pre-Assembled Kit 003193 available 11/06 to provide easier customer replacement.

⁵ 017923 Rod Weldment replaces Rod 034355, two Retaining Rings F04254-2 and one Washer 034674 supplied prior to Rev. A1.03.

⁶ Heavy springs 036136 replace 034690 springs originally supplied prior to Rev. A1.06 to allow required belt tension. Use kit 036501 to retrofit previous revisions.

4.3 Brake Assembly (DC Only)

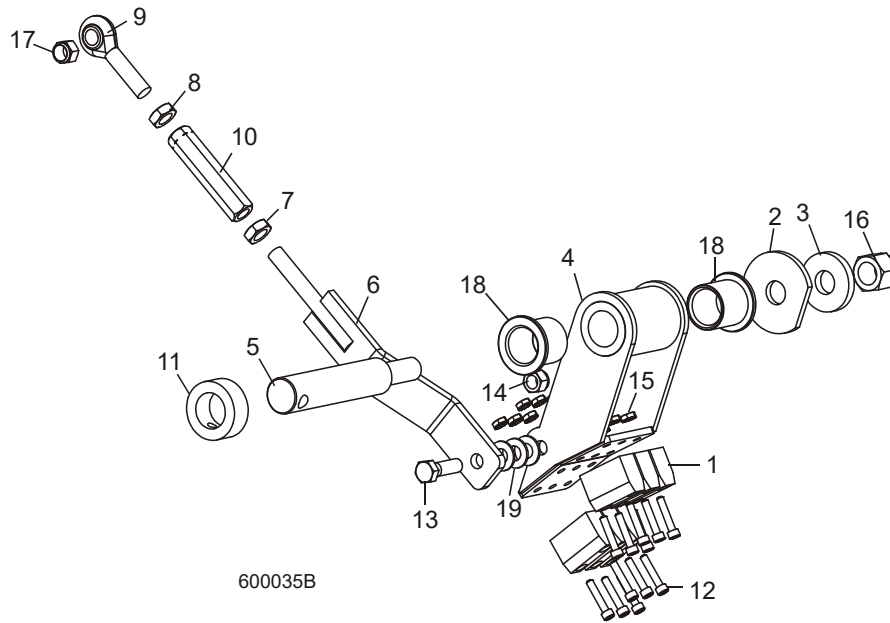

REF	DESCRIPTION (◆ Indicates Parts Available In Assemblies Only)	PART #	QTY.
	BRAKE ASSEMBLY, LT60/70	034886 ¹	1
1	Block, Blade Wheel Brake	016488	6
2	Washer, 21/32" x 2 1/4" x 3/16"	017838 ²	1
3	Washer, 21/32" x 1 5/8" x 1/4"	034685	1
4	Arm Weldment, Pivot Brake	034883	1
5	Shaft, Pivot Brake	034885	1
	Linkage Assembly, Pivot Brake	034892	1
6	Arm Weldment, Pivot Brake Lik	034891	1
7	Nut, 7/16-20 Jam	F05010-38	1
8	Nut, 7/16-20 Left Hand Jam	F05010-87	1
9	Rod End, 7/16-20 Left Hand Male	P11578	1
10	Turnbuckle, 3" Adjustment	S11577	1
11	Collar, 1" Lock	038090	1
12	Bolt, #10-24 x 1" Socket Head	F05004-2 ³	12
13	Bolt, 3/8-16 x 1" Hex Head Grade 5	F05007-87	1
14	Nut, 3/8-16 Hex Nylon Lock	F05010-10	1
15	Nut, #10-24 Self-Locking Hex	F05010-14	12
16	Nut, 5/8-18 Hex Nylon Lock	F05010-71	1
17	Nut, 7/16-20 Hex Nylon Lock	F05010-83	1
18	Bushing, 1" ID x 1 1/4" OD Flanged	P109	2

¹ Brake Assembly 034886 replaces 034691 supplied on early revisions. Old assembly and components no longer available. Use 034886 to service.

² 3/8" Thick washer 034679 replaced with 3/16" thick washer 017838 to provide more brake adjustment (Rev. A1.04)

³ Replaces F05004-50 originally supplied before 4/03 (duplicate part numbers).

4 Saw Head

Autoclutch Assembly (DC Only)

4.4 Autoclutch Assembly (DC Only)

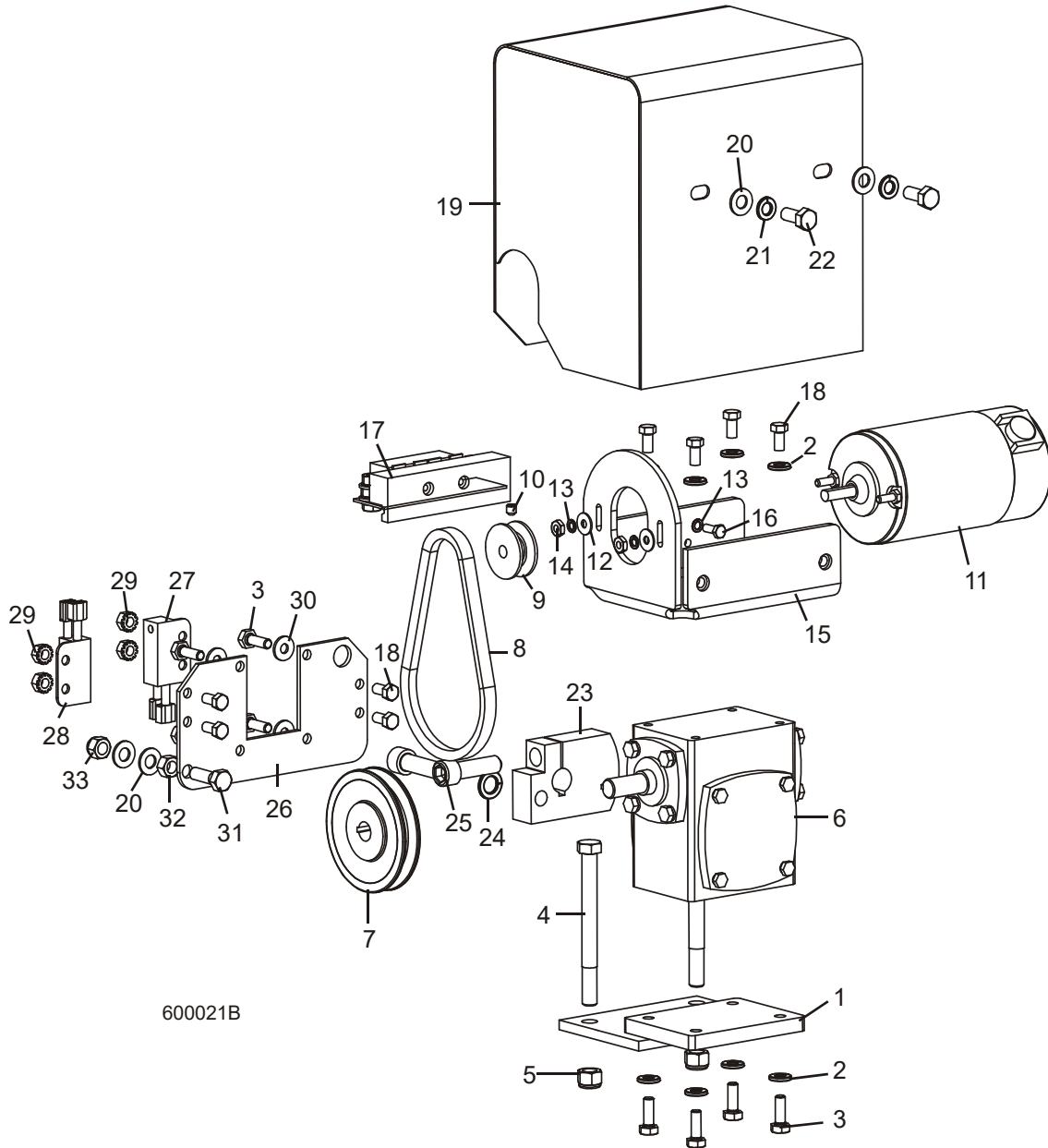

REF	DESCRIPTION (◆ Indicates Parts Available In Assemblies Only)	PART #	QTY.
	AUTOCLUTCH ASSEMBLY, LT60/70	034692 ¹	1
1	Plate Weldment, Autoclutch Mount	034678	1
2	Washer, 1/4" Split Lock	F05011-14	8
3	Bolt, 1/4-20 x 3/4" Hex Head Full Thread	F05005-1	8
4	Bolt, 3/8-16 x 4" Hex Head	F05007-4	2

5	Nut, 3/8-16 Hex Nylon Lock	F05010-10	2	
6	Gearbox, 60:1 I034	015067 ²	1	◆
7	Pulley, OK30 x 1/2" Special	015075	1	
8	Belt, 3L140	016219	1	
9	Pulley, 1.42" x .32" Motor	015074	1	
10	Screw, 1/4-28 x 1/4" Socket Head Cup Point Set	F05005-105	1	
	Brush Kit, Leeson Motor External	034002	1	
11	Motor Assembly, Autoclutch Replacement	016021	1	
12	Washer, #10 SAE Flat	F05011-18	2	
13	Washer, #10 Split Lock	F05011-20	4	
14	Nut, #10-32 Hex	F05010-27	2	
15	Bracket Weldment, Autoclutch Motor Mount	034670	1	
16	Bolt, #10-24 x 1/2" Hex Head	F05004-27	2	
	Module Kit, Autoclutch Upgrade	052791 ³	1	
17	Module Assembly, Mosfet 4X Autoclutch	024618 ³	1	◆
	Capacitor Assembly, 1000uF with 1/4" Ring Terminals	024163 ³	1	
	Diode Assembly, Autoclutch Gate	061052	1	
	Tie Wrap, 3/16" x 6" Black UV	F05089-3	1	
	Instruction Sheet, Autoclutch Mosfet Installation	052791-1260	1	
18	Bolt, 1/4-20 x 1/2" Hex Head	F05005-15	8	
19	Guard Weldment, Autoclutch	034667	1	
20	Washer, 5/16" SAE Flat	F05011-17	4	
21	Washer, 5/16" Split Lock	F05011-13	2	
22	Bolt, 5/16-18 x 3/4" Hex Head	F05006-5	2	
23	Cam, Autoclutch	034675	1	
24	Washer, 7/16" Split Lock	F05011-48	1	
25	Bolt, 7/16-20 x 1 1/2" Socket Head	F05007-55	2	
26	Plate, Sensor Mounting	016324	1	
27	Sensor Assembly, AutoClutch Engage (D51/D62)	051337 ¹	1	
	Sensor Assembly, Proximity Magnetic (D42)	024627 ¹	1	
28	Sensor Assembly, Proximity Magnetic	024627	1	
29	Nut, 1/4-20 Hex Self-Locking	F05010-9	4	
30	Washer, 1/4" SAE Flat	F05011-11	4	
31	Bolt, 5/16-18 x 1" Hex Head	F05006-1	1	
32	Nut, 5/16-18 Hex	F05010-17	1	
33	Nut, 5/16-18 Hex Nylon Lock	F05010-58	1	

¹ Autoclutch Assembly 034692 modified for use with Caterpillar engine options (Rev. A2.02). If assembly to be used on sawmill with D42 Kubota engine, leave white wire from Engage Sensor 051337 unused. If replacing Engage Sensor, use 024627 for D42 and use 051337 for D51/D62.

² Gearbox 015067 replaced 3/05 to improve durability. Use Gearbox Assembly 036787 to retrofit previous revisions.

³ Use Mosfet Module Upgrade Kit 052791 to replace original Mosfet Module 024618. Upgrade includes Capacitor Assembly 024163 and Mosfet Assembly with added diode supplied 5/06 and later. This upgrade protects against inductive voltage spikes.

4 Saw Head

Board Return Assembly

4.5 Board Return Assembly

LT60HD/70HD

Rev. A2.02 - A3.00

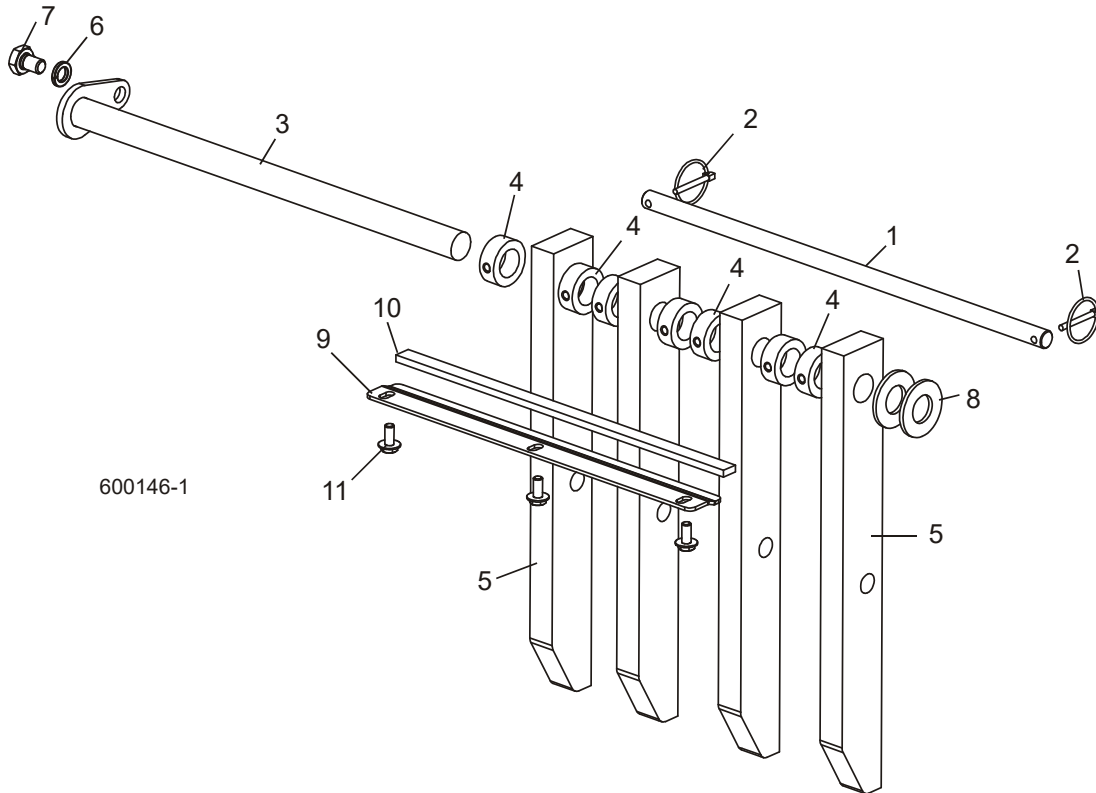

REF	DESCRIPTION (◆ Indicates Parts Available In Assemblies Only)	PART #	QTY.
1	PIN, BOARD RETURN LOCK	034565	1
2	PIN, 3/16" W/CHAIN	017604	2
3	PIN WELDMENT, BOARD RETURN MOUNT	034567	1
4	COLLAR, 1" LOCK	038090	7
5	ARM, BOARD RETURN W/STOP	034561 ¹	4
6	WASHER, 1/2" SPLIT LOCK	F05011-9	1
7	BOLT, 1/2-13 X 3/4" HEX HEAD GRADE 5	F05008-101	1
8	WASHER, 1" SAE	F05011-28	2
9	BRACKET, BOARD RETURN BUMPER	017856	1
10	BUMPER, BOARD RETURN	017857	1
11	BOLT, 5/16-18 X 3/4" HEX WASHER HEAD	F05006-101	3

¹ Board Return Arm 034561 replaces arm 036172 originally supplied prior to Rev. A2.02. New arm prevents possible overloading of power feed during return.

4.6 Board Return Assembly

LT60HD/70HD

Rev. A2.00 - A2.01

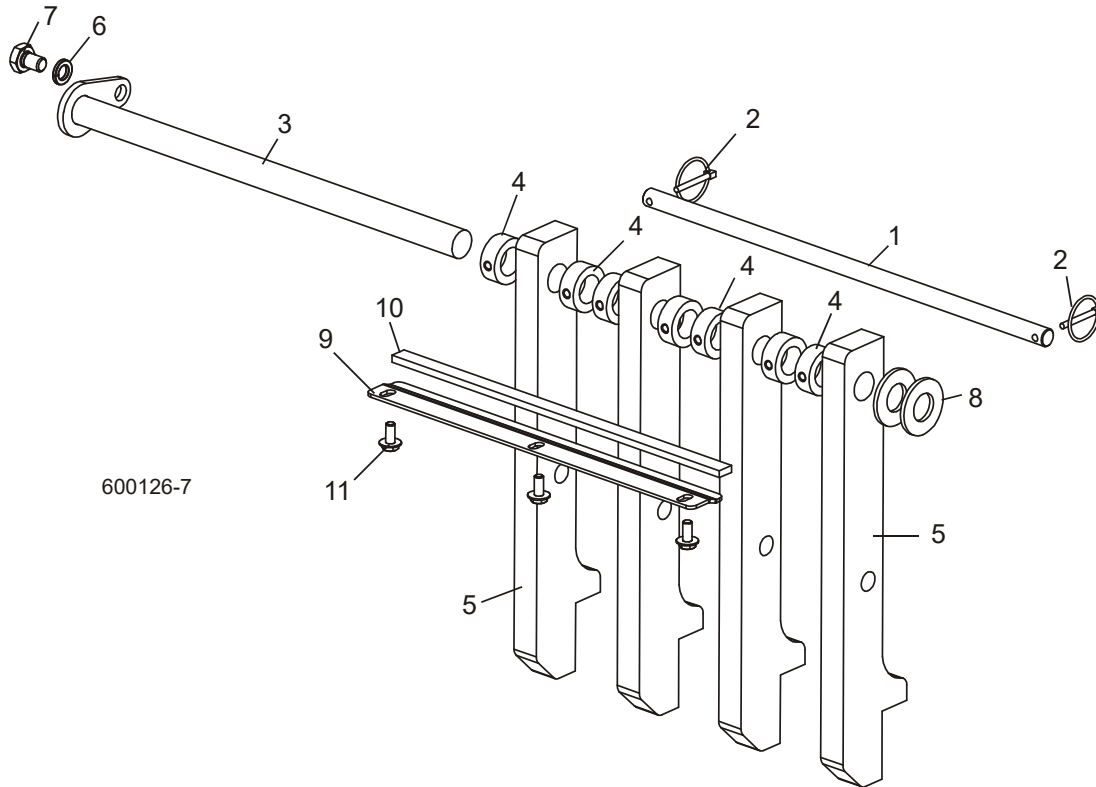

REF	DESCRIPTION (◆ Indicates Parts Available In Assemblies Only)	PART #	QTY.
1	PIN, BOARD RETURN LOCK	034565	1
2	PIN, 3/16" W/CHAIN	017604	2
3	PIN WELDMENT, BOARD RETURN MOUNT	034567	1
4	COLLAR, 1" LOCK	038090	7
5	ARM, BOARD RETURN W/STOP	036172 ¹	4
6	WASHER, 1/2" SPLIT LOCK	F05011-9	1
7	BOLT, 1/2-13 X 3/4" HEX HEAD GRADE 5	F05008-101	1
8	WASHER, 1" SAE	F05011-28	2
9	BRACKET, BOARD RETURN BUMPER	017856	1
10	BUMPER, BOARD RETURN	017857	1
11	BOLT, 5/16-18 X 3/4" HEX WASHER HEAD	F05006-101	3

¹ Board Return Arm w/Stop 036172 replaces arm 034561 originally supplied prior to Rev. A2.00. New arm prevents board from lifting during return.

4 Saw Head

Board Return Assembly

4.7 Board Return Assembly

LT60HD/70HD

Rev. A1.00 - A1.09

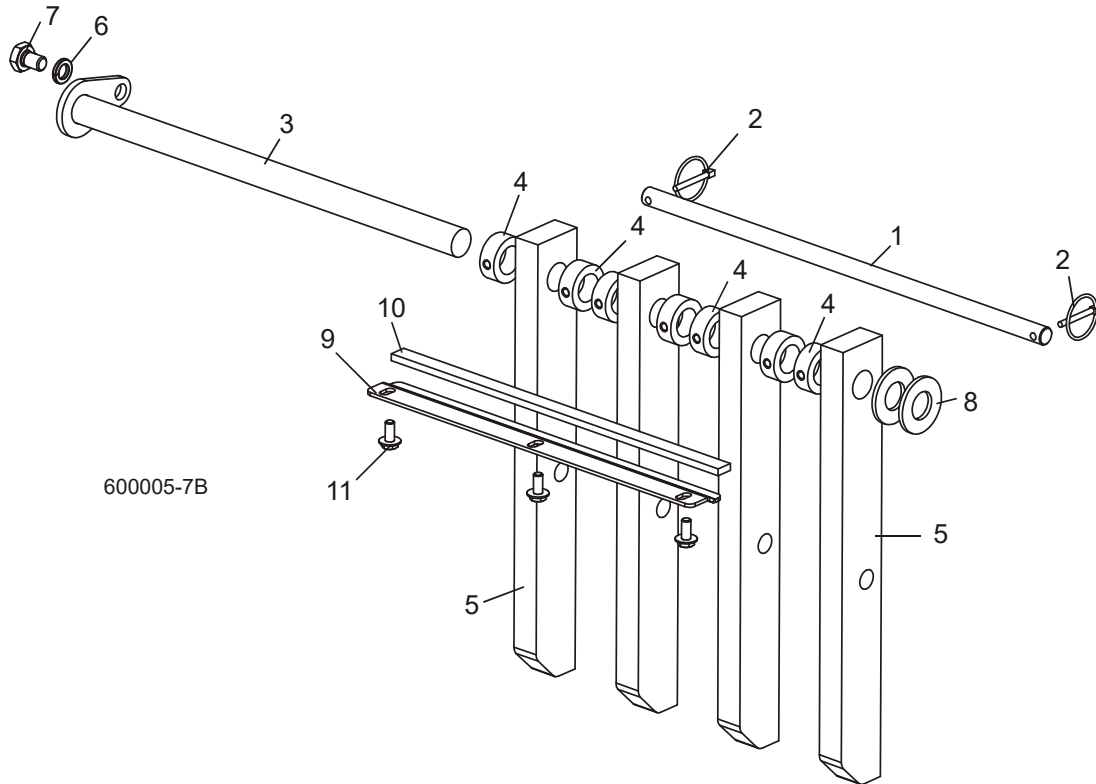

REF	DESCRIPTION (◆ Indicates Parts Available In Assemblies Only)	PART #	QTY.
1	PIN, BOARD RETURN LOCK	034565	1
2	PIN, 3/16" W/CHAIN	017604	2
3	PIN WELDMENT, BOARD RETURN MOUNT	034567	1
4	COLLAR, 1" LOCK	038090	7
5	ARM, BOARD RETURN	034561 ¹	4
6	WASHER, 1/2" SPLIT LOCK	F05011-9	1
7	BOLT, 1/2-13 X 3/4" HEX HEAD GRADE 5	F05008-101	1
8	WASHER, 1" SAE	F05011-28	2
9	BRACKET, BOARD RETURN BUMPER	017856 ²	1
10	BUMPER, BOARD RETURN	017857 ²	1
11	BOLT, 5/16-18 X 3/4" HEX WASHER HEAD	F05006-101 ²	3

¹ Board Return Arm 034561 replaced with new arm with stop 036172 (Rev. A2.00 - [See Section 4.6](#)).

² Bumper parts added Rev. A1.02.

4.8 Board Dragback

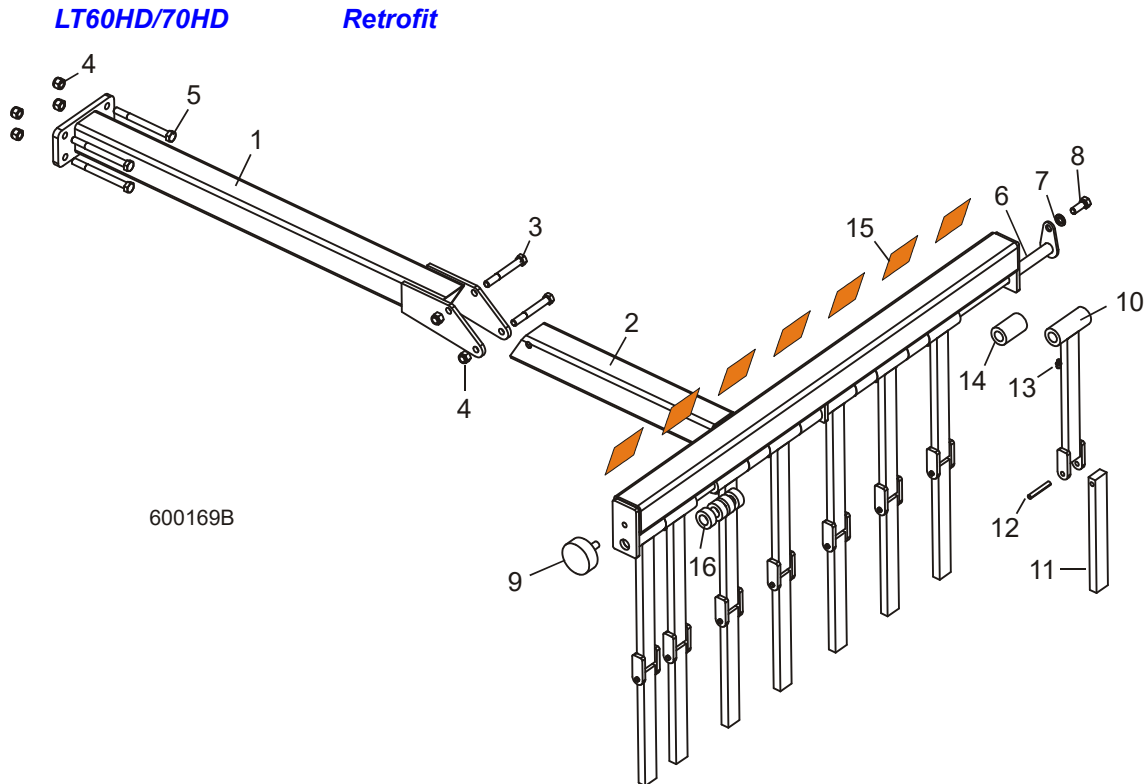

REF	DESCRIPTION (◆ Indicates Parts Available In Assemblies Only)	PART #	QTY.
	DRAGBACK ASSEMBLY, BOARD	034413 ¹	1
1	Tube Weldment, Board Dragback Mount	034411	1
2	Tube Weldment, Board Dragback	034331	1
3	Bolt, 3/8-16 x 3" Hex Head Grade 5	F05007-73	2
4	Nut, 3/8-16 Hex Nylon Lock	F05010-10	6
5	Bolt, 3/8-16 x 4" Hex Head Grade 5	F05007-126	4
6	Rod Weldment, Board Dragback	034408	1
7	Washer, 3/8" Split Lock	F05011-4	1
8	Bolt, 3/8-16 x 1" Hex Head Grade 5	F05007-87	1
9	Bumper, Table	034175	1
10	Bracket Weldment, Dragback Bar Mount	017823 ¹	8
11	Bar, Lower Board Dragback	036651 ¹	8
12	Pin, 1/4" x 1 3/4" Roll	F05012-53	8
13	Fitting, 1/4-28 Grease	P05060	8
14	Tube, .63" ID x 1.12" OD x 1.84" Long Spacer	017820	6
15	Decal, Warning Stripe	015849	1

¹ Dragback Bar Mount Weldment 017823 and Lower Dragback Bar 036651 replace 034329 and 034328 originally supplied to utilize common parts from other models. Dragback bars and spacers rearranged to provide more efficient dragging of boards. [See Section 4.9](#) for replacement parts for original assembly.

4 Saw Head

Board Dragback

4.9 Board Dragback

LT60HD/70HD

Rev. A1.00 - A3.00

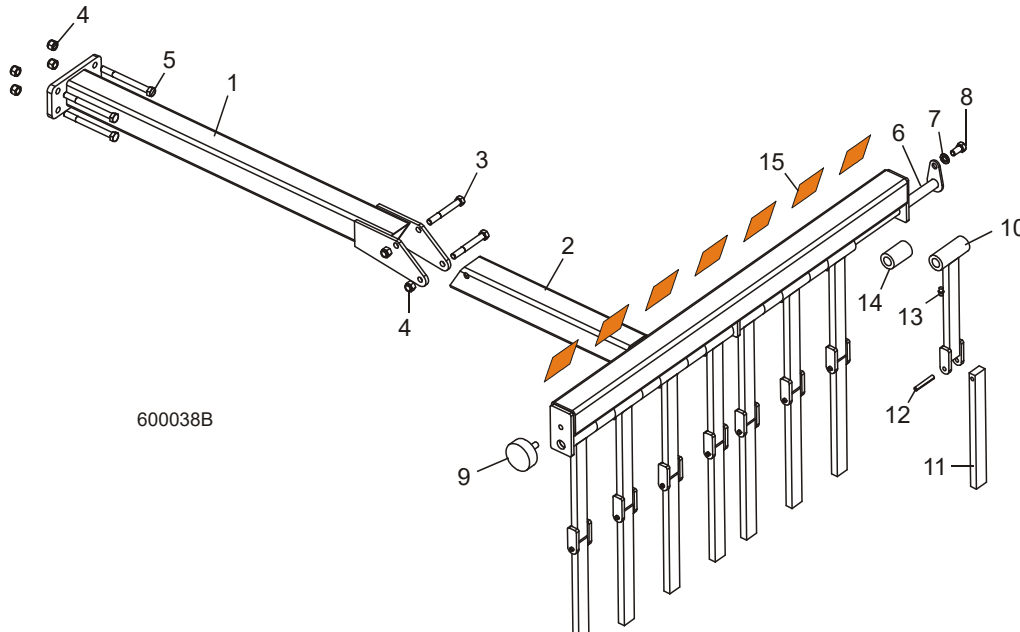

REF	DESCRIPTION (◆ Indicates Parts Available In Assemblies Only)	PART #	QTY.
	DRAGBACK ASSEMBLY, BOARD	034413 ¹	1
1	Tube Weldment, Board Dragback Mount	034411	1
2	Tube Weldment, Board Dragback	034331	1
3	Bolt, 3/8-16 x 3" Hex Head Grade 5	F05007-73	2
4	Nut, 3/8-16 Hex Nylon Lock	F05010-10	6
5	Bolt, 3/8-16 x 4" Hex Head Grade 5	F05007-126	4
6	Rod Weldment, Board Dragback	034408	1
7	Washer, 3/8" Split Lock	F05011-4	1
8	Bolt, 3/8-16 x 1" Hex Head Grade 5	F05007-87 ²	1
9	Bumper, Table	034175	1
10	Bracket Weldment, Dragback Bar Mount	034329 ³	8
11	Bar, Board Dragback	034328 ³	8
12	Pin, 1/4" x 1 3/4" Roll	F05012-53	8
13	Fitting, 1/4-28 Grease	P05060	8
14	Tube, .63" ID x 1.12" OD x 1.84" Long Spacer	017820	6
15	Decal, Warning Stripe	015849 ²	1

¹ Dragback Assembly 034413 revised 10/02 to make assembly consistent with other models. Quantity of bars reduced from 12 to 8, added spacers 017820, grease fittings P05060 and warning stripe decal 016834.

² Bolt F05007-87 replaces F05007-118 and Decal 015849 replaces 016834 originally supplied prior to 12/02. Parts are interchangeable.

³ Dragback Bar Mount Weldment 017823 and Lower Dragback Bar 036651 replace 034329 and 034328 originally supplied to utilize common parts from other models. [See Section 4.8](#) for replacement parts for new assembly.

4.10 Water Lube Assembly

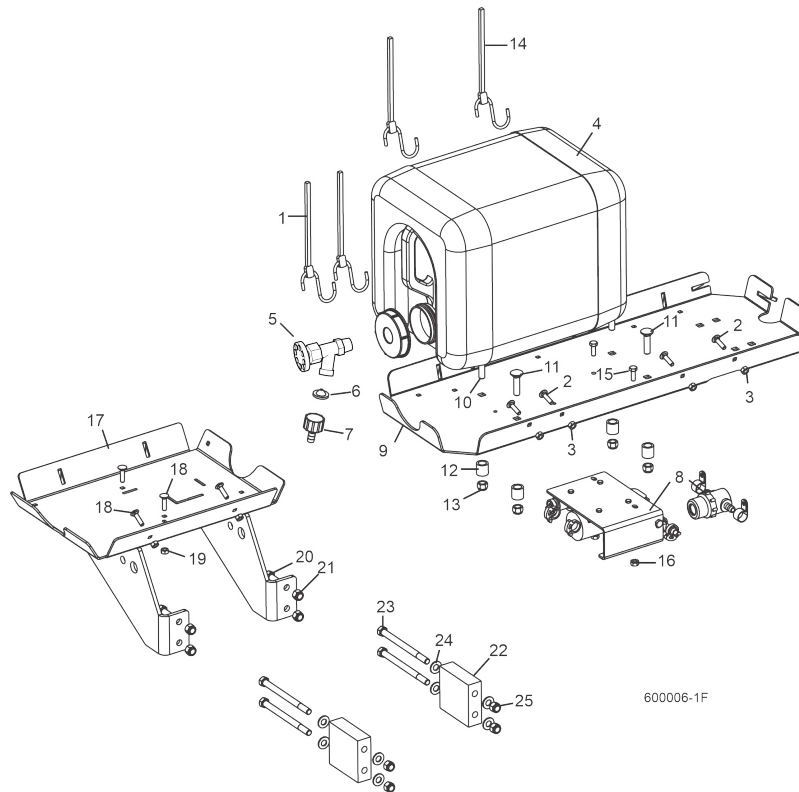

600006-1F

REF	PART #	DESCRIPTION	COMMENTS	QTY.
1	P11668	STRAP, 20" RUBBER		2
2	F05005-34	BOLT, 1/4-20 X 1" CARRIAGE HEAD		4
3	F05010-21	NUT, 1/4-20 HEX LOCK		4
4	014642	BOTTLE ASSEMBLY, WATER LUBE W/CAP		1
	061372 ¹	O-ring, Water Bottle Cap	If the water bottle cap keeps leaking, add this o-ring to the cap. Leave the existing o-ring installed.	1
	014636	FITTING, 3/4FPT X 3/4MPT	Removed after 9/19/2024 per ECN 38718.	1
5	133320	VALVE, 3/4 NPT ELBOW 3/4 MALE GHT OUTLET	Replaced 014100 after 9/19/2024 per ECN 38718.	1
	014100	FITTING, WATER LUBE SHUTOFF VALVE		1
6	016086	FILTER, WATER LUBE		1
7	014113	FITTING, 5/8" NPT TO 3/8" HOSE BARB		1
8		LUBEMIZER PARTS/HOSES (SEE LUBEMIZER OPTION MANUAL)		
9	S11684 ²	TRAY, WATER LUBE/FUEL TANK MOUNT (GAS/DIESEL ONLY)	See Engine Option manual for fuel tank parts.	1
10	F05007-22	BOLT, 3/8-16 X 2" CARRIAGE HEAD FULL THREAD		1
11	F05007-85	BOLT, 3/8-16 X 1 1/2" CARRIAGE HEAD GRADE 5		3

4**Saw Head***Water Lube Assembly*

REF	PART #	DESCRIPTION	COMMENTS	QTY.
12	033911	SPACER, TANK TRAY		4
13	F05010-10	NUT, 3/8-16 HEX NYLON LOCK		4
14	P11258	STRAP, 24" RUBBER (GAS/DIESEL ONLY)		2
15	F05005-1	BOLT, 1/4-20 X 3/4" HEX HEAD FULL THREAD		2
16	F05010-9	NUT, 1/4-20 HEX SELF-LOCKING		2
17	034491	TRAY WELDMENT, WATER LUBE MOUNT (E25/E30 ONLY)		1
18	F05005-34	BOLT, 1/4-20 X 1" CARRIAGE HEAD		4
19	F05010-21	NUT, 1/4-20 HEX LOCK		4
20	F05007-7	BOLT, 3/8-16 X 1" HEX HEAD		4
21	F05010-10	NUT, 3/8-16 HEX NYLON LOCK		4
22	007660	SPACER, E30 WATERLUBE (E30 ONLY)		2
23	F05007-5	BOLT, 3/8-16 X 5" HEX HEAD		4
24	F05011-3	WASHER, 3/8" SAE FLAT		8
25	F05010-10	NUT, 3/8-16 HEX NYLON LOCK		4
	CBOTTLE	COVER, 5 GAL. WATER BOTTLE OPTIONAL (NOT SHOWN)		1

¹ Use Water Bottle Assembly w/Cap 014642 to service all bottle/cap combinations previously supplied. Bottle 014367, 61mm Cap 014773 and 70mm Cap 036744 no longer available separately.

² See Engine Option manual for fuel tank parts.

4.11 Saw Head Decals

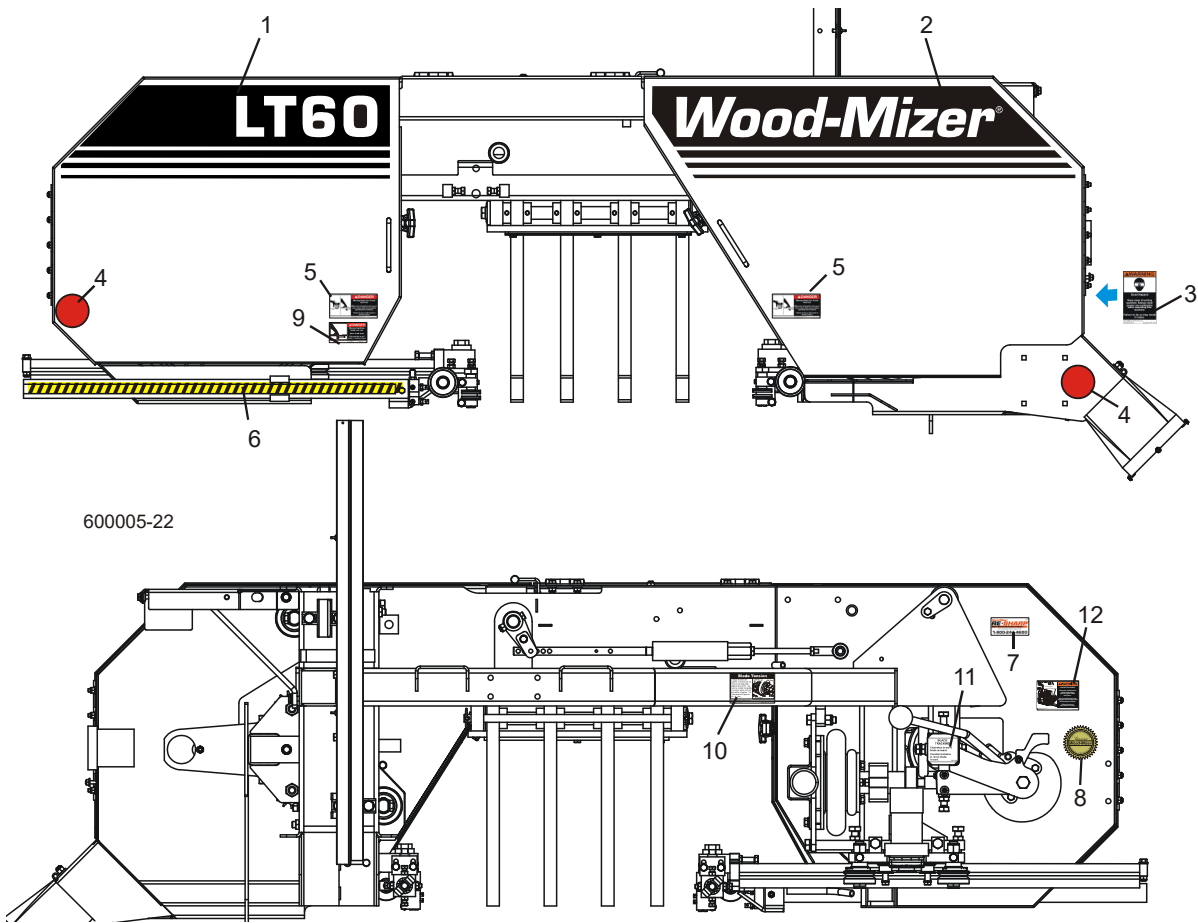

600005-22

REF	DESCRIPTION (◆ Indicates Parts Available In Assemblies Only)	PART #	QTY.
1	DECAL, LT70 LOGO	017667	1
2	DECAL, WOOD-MIZER LOGO	017668	1
3	DECAL, SAWDUST CHUTE WARNING	P11754	1
4	DECAL, RED REFLECTIVE 2" ROUND	P07452	2
5	DECAL, BLADE COVERS DANGER	033254	2
6	DECAL, BLADE GUIDE ARM STRIPE	015849	1
7	DECAL, BLADE RESHARP INFO	P12879	1
8	DECAL, WOOD-MIZER QUALITY	015930	1
9	DECAL, BLADE DANGER	S11752	1
10	DECAL, LT60/70 BLADE TENSION INFO	014125	1
11	DECAL, BLADE ALIGNMENT	P11789	1
12	DECAL, TENSION HANDLE WARNING	049366 ¹	1

¹ Decal 049366 added to warn user to use both hands when operating tensioner and be sure lock plates engage when blade is tensioned (8/05).

4 Saw Head

Blade Housing Covers

4.12 Blade Housing Covers

LT60HD/70HD

Rev. A2.00 - A3.00

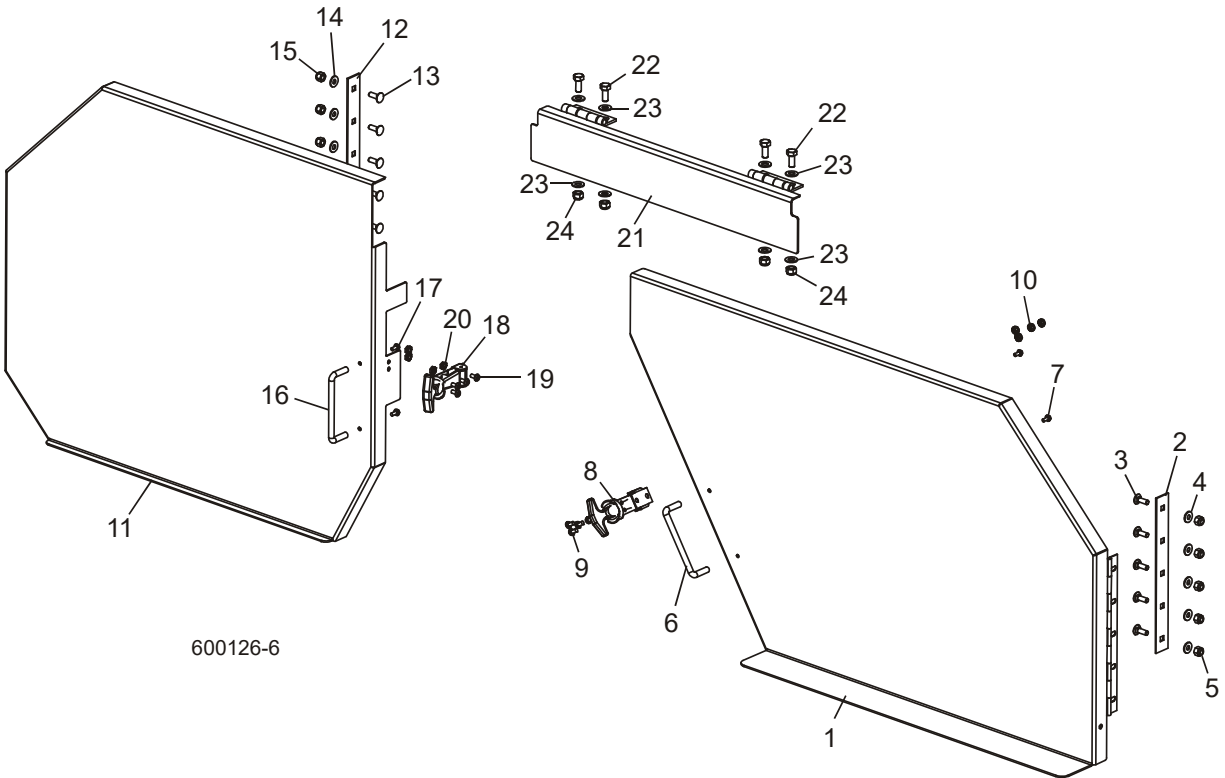

REF	DESCRIPTION (◆ Indicates Parts Available In Assemblies Only)	PART #	QTY.
	COVER ASSEMBLY, DRIVE SIDE BLADE HOUSING	036177	1
1	Cover Weldment, Drive Side Blade Housing	036175	1
2	Plate, Hinge Backing	034251	1
3	Bolt, 1/4-20 x 3/4" Carriage Head	F05005-113	5
4	Washer, 1/4" SAE Flat	F05011-11	5
5	Nut, 1/4-20 Hex Nylon Lock	F05010-69	5
6	Handle, Blade Housing Cover	P08065	1
7	Screw, #8-32 x 3/8" Self-Tapping	F05015-8	2
8	Latch, Flexible Draw	014829	1
9	Screw, #10-24 x 3/8" Cross Slotted Pan Head	F05004-3	4
10	Nut, #10-24 Hex Self-Locking	F05010-14	4
	COVER ASSEMBLY, IDLE SIDE BLADE HOUSING	036178	1
11	Cover Weldment, Idle Side Blade Housing	036176	1
12	Plate, Hinge Backing	034251	1
13	Bolt, 1/4-20 x 3/4" Carriage Head	F05005-113	5
14	Washer, 1/4" SAE Flat	F05011-11	5
15	Nut, 1/4-20 Hex Nylon Lock	F05010-69	5

16	Handle, Blade Housing Cover	P08065	1	
17	Screw, #8-32 x 3/8" Self-Tapping	F05015-8	2	
18	Latch, Flexible Draw	014829	1	
19	Screw, #10-24 x 3/8" Cross Slotted Pan Head	F05004-3	4	
20	Nut, #10-24 Hex Self-Locking	F05010-14	4	
21	COVER WELDMENT, MIDDLE BLADE HOUSING	034454	1	
22	BOLT, 5/16-18 X 3/4" HEX HEAD	F05006-102	4	
23	WASHER, 5/16" SAE FLAT	F05011-17	8	
24	NUT, 5/16-18 HEX NYLON LOCK	F05010-58	4	

4 Saw Head

Blade Housing Covers

4.13 Blade Housing Covers

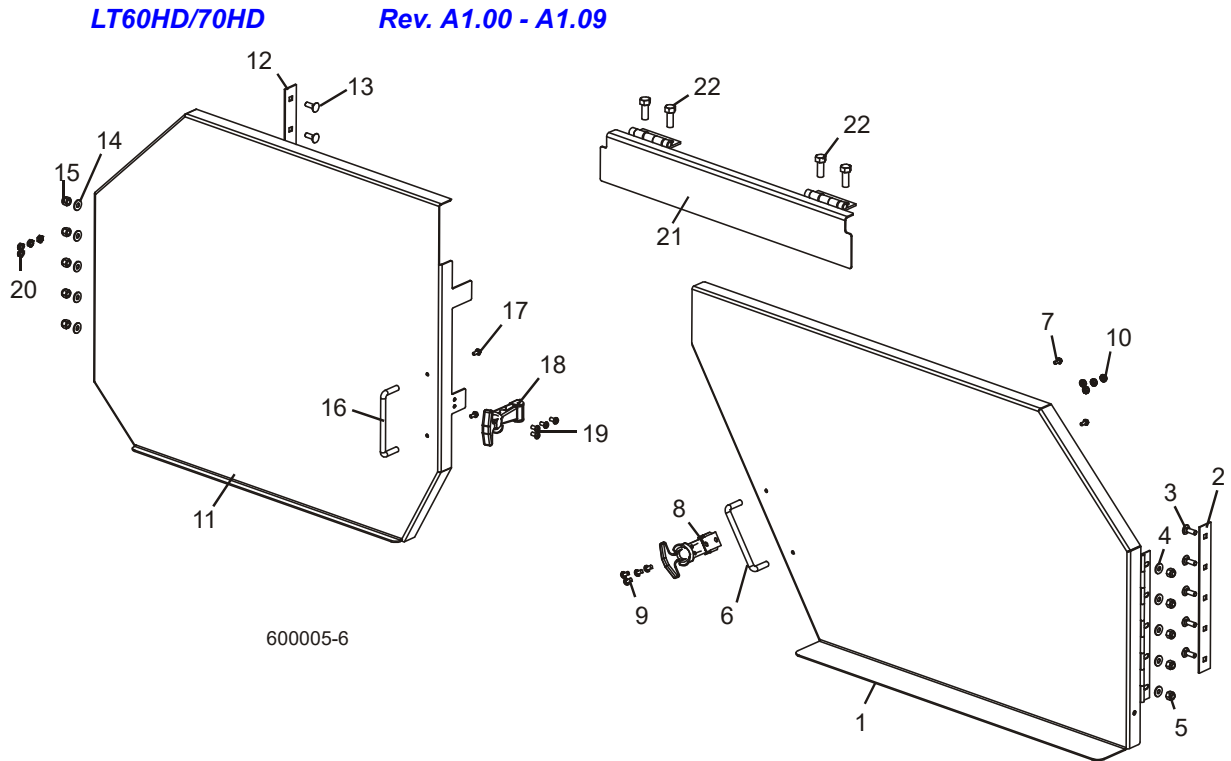

REF	DESCRIPTION (◆ Indicates Parts Available In Assemblies Only)	PART #	QTY.	
	COVER ASSEMBLY, DRIVE SIDE BLADE HOUSING	034374	1	
1	Cover Weldment, Drive Side Blade Housing	034317	1	◆
2	Plate, Hinge Backing	034251	1	
3	Bolt, 1/4-20 x 3/4" Carriage Head	F05005-113	5	
4	Washer, 1/4" SAE Flat	F05011-11	5	
5	Nut, 1/4-20 Hex Nylon Lock	F05010-69	5	
6	Handle, Blade Housing Cover	P08065	1	
7	Screw, #8-32 x 3/8" Self-tapping	F05015-8	2	
8	Latch, Flexible Draw	014829	1	
9	Screw, #10-24 x 3/8" Cross Slotted Pan Head	F05004-3	4	
10	Nut, #10-24 Hex Self-Locking	F05010-14	4	
	COVER ASSEMBLY, IDLE SIDE BLADE HOUSING	034375	1	
11	Cover Weldment, Idle Side Blade Housing	034318	1	◆
12	Plate, Hinge Backing	034251	1	
13	Bolt, 1/4-20 x 3/4" Carriage Head	F05005-113	5	
14	Washer, 1/4" SAE Flat	F05011-11	5	
15	Nut, 1/4-20 Hex Nylon Lock	F05010-69	5	
16	Handle, Blade Housing Cover	P08065	1	
17	Screw, #8-32 x 3/8" Self-tapping	F05015-8	2	

18	Latch, Flexible Draw	014829	1	
19	Screw, #10-24 x 3/8" Cross Slotted Pan Head	F05004-3	4	
20	Nut, #10-24 Hex Self-Locking	F05010-14	4	
21	COVER WELDMENT, MIDDLE BLADE HOUSING	034454	1	
22	BOLT, 3/8-16 X 1" HEX HEAD	F05007-7	4	

4.14 Sawdust Chute

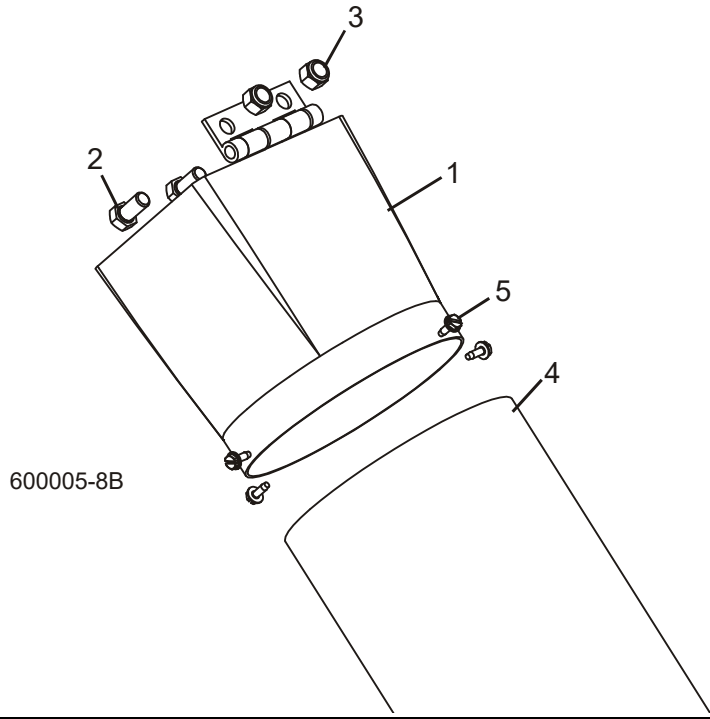

REF	DESCRIPTION (◆ Indicates Parts Available In Assemblies Only)	PART #	QTY.	
1	CHUTE WELDMENT, SAWDUST	034396	1	
2	BOLT, 3/8-16 X 3/4" HEX HEAD GRADE 5	F05007-118	2	
3	NUT, 3/8-16 HEX NYLON LOCK	F05010-10	2	
4	TUBE, SAWDUST CHUTE	017829 ¹	1	
5	BOLT, #10-24 X 1/2" SELF-TAPPING	F05015-7	4	

¹ Sawdust Chute Tube 017829 and mounting screws F05015-7 added Rev. A1.02.

4.15 Debarker Wire Box/Grommet

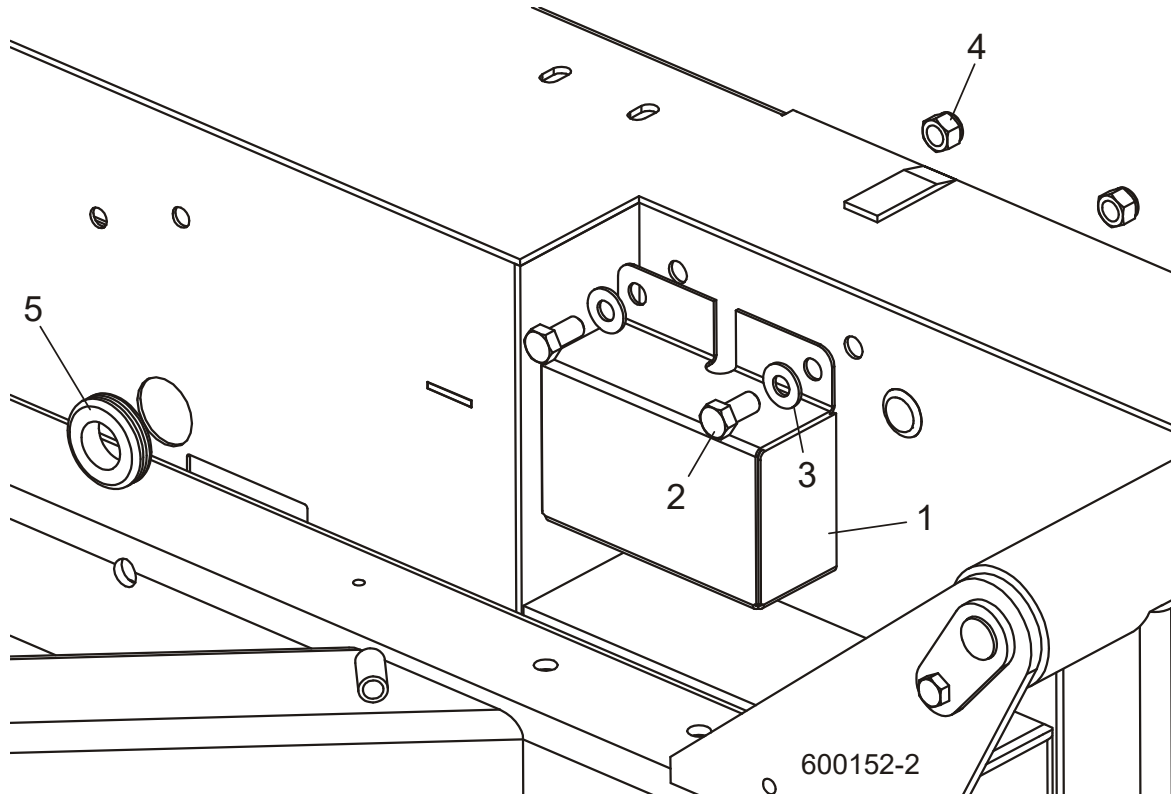

REF	DESCRIPTION (◆ Indicates Parts Available In Assemblies Only)	PART #	QTY.
1	BOX, DEBARKER WIRE STORAGE	023616	1
2	BOLT, 3/8-16 X 3/4" HEX HEAD	F05007-7	2
3	WASHER, 3/8" SAE FLAT	F05011-3	2
4	NUT, 3/8-16 HEX NYLON LOCK	F05010-10	2
5	GROMMET, 7/8" ID X 1 1/4" GROOVED OD	P702	1

SECTION 5 CONTROL & BATTERY BOXES

5.1 Control Assembly (DC)

LT70HD Remote

Rev. A2.02 - A3.00

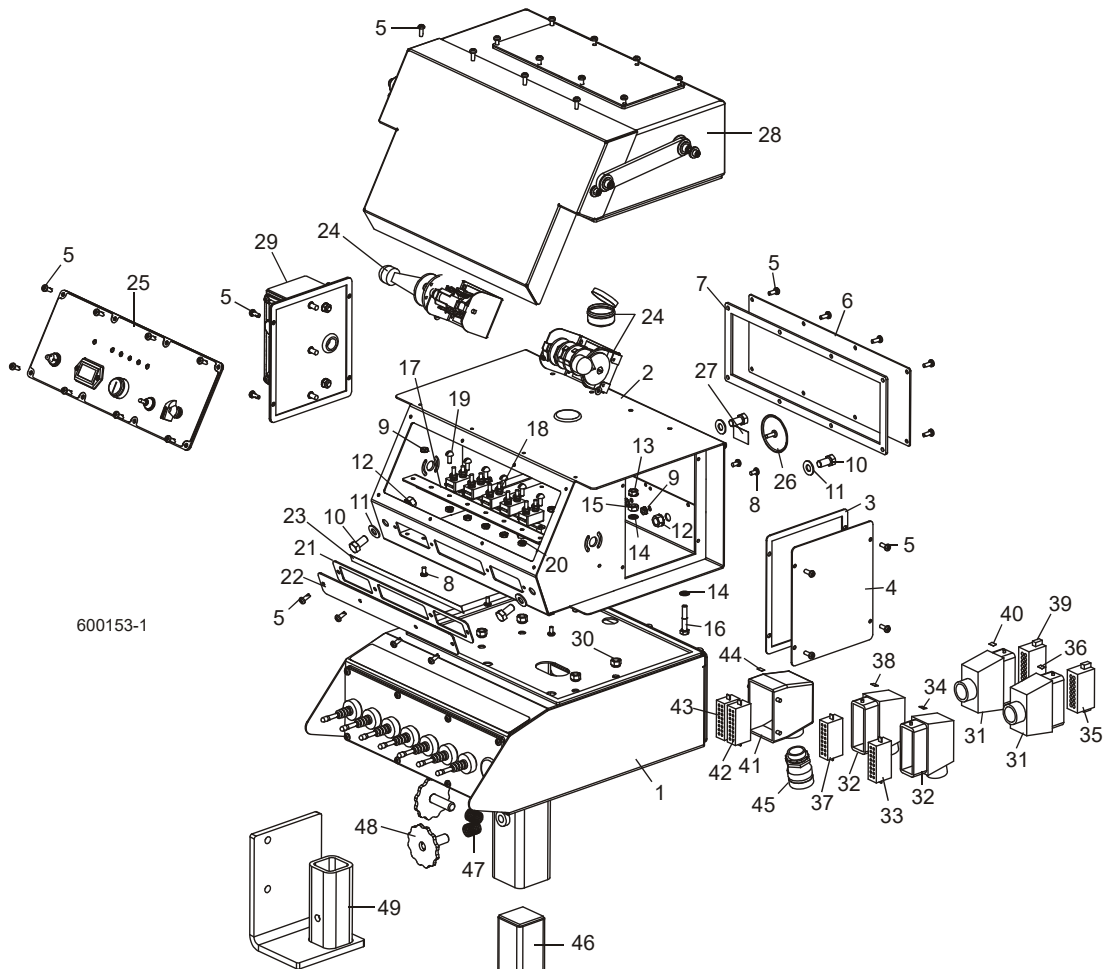

REF	DESCRIPTION (◆ Indicates Parts Available In Assemblies Only)	PART #	QTY.	
	COVER, LT70HD REMOTE CONTROL COVER	036352	1	
	CONTROL BOX ASSEMBLY, LT70HD DIESEL REMOTE	050960	1	
1	Remote Hydraulic Control Parts (See Section 10.2)			
2	Box Weldment, Control	016135	1	◆
3	Gasket, Side Panel Control 97	015274	1	
4	Panel Weldment, Side	015307	1	
5	Screw, #10-24 x 1/2" Pan Head	F05015-17	32	
6	Panel, Rear Mill Control 97	016230	1	
7	Gasket, Rear Panel 97	015278	1	
8	Screw, 10-24 x 3/8" Phillips Pan Head Machine	F05004-3	5	

9	Nut, #10-24 Self-Locking	F05010-14	5	
10	Bolt, 3/8-16 x 3/4" Hex Head	F05007-27	4	
11	Washer, 3/8" Flat	F05011-3	4	
12	Nut, 3/8-16 Self-Locking	F05010-19	4	
13	Nut, 1/4-20 Self-Locking	F05010-9	1	
14	Washer, 1/4" Interior Star Lock (Heavy Duty)	F05011-69	2	
15	Nut, 1/4-20 Hex Jam (Heavy Duty)	F05010-129	1	
16	Bolt, 1/4-20 x 1 1/2" Hex Head Full Thread	F05005-31	1	
	Breaker Assembly, Remote Control Front	015621	1	
17	Rail, Circuit Breaker	015310	1	
18	Breaker, 15Amp Auto Reset	E20430	5	
19	Screw, #8-32 x 1/2" Slotted Head	F05004-12	10	
20	Nut, #8-32 Hex Self-Locking	F05010-41	10	
21	Gasket, Circuit Breaker Cover	015266	1	
22	Panel, Circuit Breaker Cover	015376	1	
23	Decal, Circuit Breaker Remote Control 97	024363	1	
24	Drum Switch Parts (See Section 5.7)			
25	Control Panel Parts (See Section 5.8)			
26	Plug, AS125 Oil Tight Painted	015673	1	
27	Decal, Circuit Breaker ID (Debarker In/Out)	024364	1	
28	Accuset Parts (See Accuset Manual)			
29	LubeMizer Parts (See LubeMizer Manual)			
30	Nut, 5/16-18 Nylon Lock	F05010-58	4	
	HARNES ASSEMBLY, LT70HD DIESEL REMOTE	050742 ¹	1	
31	Connector, 16 Pin Hood Single Lever	015658	2	
32	Connector, 16 Pin Hood Single Lever 90°	051499 ¹	2	
33	Insert, Female 10A 16 Pin Screw Terminal 1-16	E23106	1	
34	Decal, Connector ID P1A	038412	1	
35	Insert, Male 10A 16 Pin Screw Terminal 1-16	E23105	1	
36	Decal, Connector ID P1B	038417	1	
37	Insert, Female 10A 16 Pin Screw Terminal 17-32	015671	1	
38	Decal, Connector ID P2A	038413	1	
39	Insert, Male 10A 16 Pin Screw Terminal 17-32	015670	1	
40	Decal, Connector ID P2B	038418	1	
	HARNES ASSEMBLY, LT70 REMOTE HYDRAULIC JOYSTICK	050965 ¹	1	
41	Connector, 32 Pin Hood Dual Lever 90°	051500 ¹	1	
42	Insert, Female 10A 16 Pin Screw Terminal 1-16	E23106	1	
43	Insert, Female 10A 16 Pin Screw Terminal 17-32	015671	1	
44	Decal, Connector ID P3A	038414	1	
45	Connector, Flex Strain .53 - .75 Cord 3/4" Hub	025186	1	
46	STAND WELDMENT, REMOTE CONTROL	034652	1	
47	SPRING, .72" X 1.5" X .067" STAINLESS STEEL COMPRESSION	P04282	2	
48	KNOB WELDMENT, LOCK	034658	2	

5 Control & Battery Boxes

Control Assembly (DC)

49	MOUNT WELDMENT, LT70 REMOTE CONTROL BOX STORAGE	046443 ²	1	
----	---	---------------------	---	--

¹ 16-Pin Harness Connector Housing 015658 and 32-Pin Connector Housing 050819 replaced with 90° connectors (Rev. A3.00).

² New storage bracket 046443 replaces storage bracket assembly 036167 to accommodate new board return table (Rev. A2.02).

5.2 Control Assembly (DC)

LT70HD Remote

Rev. A1.09 - A2.01

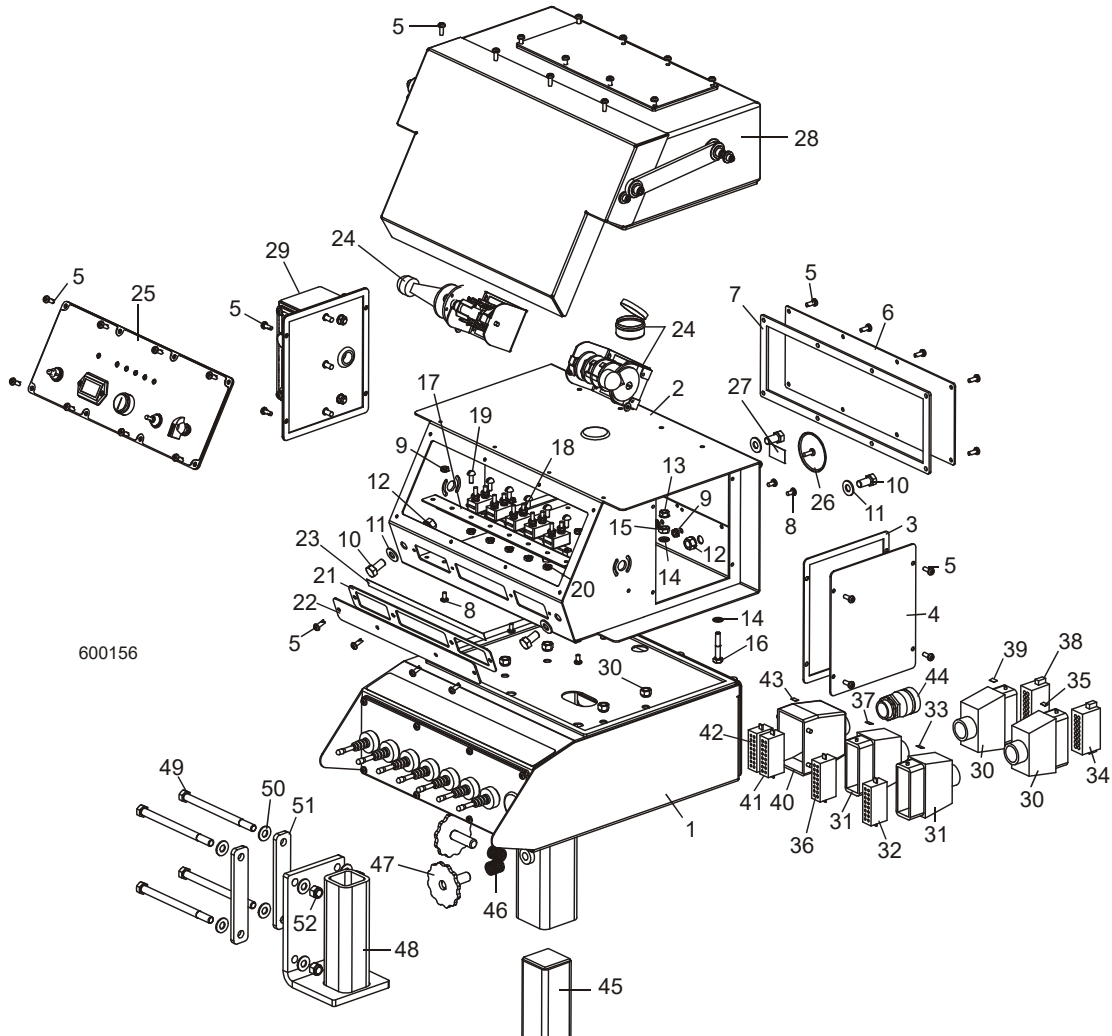

REF	DESCRIPTION (◆ Indicates Parts Available In Assemblies Only)	PART #	QTY.	
	COVER, LT70HD REMOTE CONTROL COVER	036352	1	
	CONTROL BOX ASSEMBLY, LT70HD DIESEL REMOTE	050960	1	
1	Remote Hydraulic Control Parts (See Section 10.2)			
2	Box Weldment, Control	016135	1	◆
3	Gasket, Side Panel Control 97	015274	1	
4	Panel Weldment, Side	015307	1	
5	Screw, #10-24 x 1/2" Pan Head	F05015-17	32	
6	Panel, Rear Mill Control 97	016230	1	
7	Gasket, Rear Panel 97	015278	1	
8	Screw, 10-24 x 3/8" Phillips Pan Head Machine	F05004-3	5	

5 Control & Battery Boxes

Control Assembly (DC)

9	Nut, #10-24 Self-Locking	F05010-14	5	
10	Bolt, 3/8-16 x 3/4" Hex Head	F05007-27	4	
11	Washer, 3/8" Flat	F05011-3	4	
12	Nut, 3/8-16 Self-Locking	F05010-19	4	
13	Nut, 1/4-20 Self-Locking	F05010-9	1	
14	Washer, 1/4" Interior Star Lock (Heavy Duty)	F05011-69	2	
15	Nut, 1/4-20 Hex Jam (Heavy Duty)	F05010-129	1	
16	Bolt, 1/4-20 x 1 1/2" Hex Head Full Thread	F05005-31	1	
	Breaker Assembly, Remote Control Front	015621	1	
17	Rail, Circuit Breaker	015310	1	
18	Breaker, 15Amp Auto Reset	E20430	5	
19	Screw, #8-32 x 1/2" Slotted Head	F05004-12	10	
20	Nut, #8-32 Hex Self-Locking	F05010-41	10	
21	Gasket, Circuit Breaker Cover	015266	1	
22	Panel, Circuit Breaker Cover	015376	1	
23	Decal, Circuit Breaker Remote Control 97	024363	1	
24	Drum Switch Parts (See Section 5.7)			
25	Control Panel Parts (See Section 5.8)			
26	Plug, AS125 Oil Tight Painted	015673	1	
27	Decal, Circuit Breaker ID (Debarker In/Out)	024364	1	
28	Accuset Parts (See Accuset Manual)			
29	LubeMizer Parts (See LubeMizer Manual)			
30	Nut, 5/16-18 Nylon Lock	F05010-58	4	
	HARNESS ASSEMBLY, LT70D42-R/D62-R CONTROL	050742 ¹	1	
31	Connector, 16 Pin Hood Single Lever	015658	4	
32	Insert, Female 10A 16 Pin Screw Terminal 1-16	E23106	1	
33	Decal, Connector ID P1A	038412	1	
34	Insert, Male 10A 16 Pin Screw Terminal 1-16	E23105	1	
35	Decal, Connector ID P1B	038417	1	
36	Insert, Female 10A 16 Pin Screw Terminal 17-32	015671	1	
37	Decal, Connector ID P2A	038413	1	
38	Insert, Male 10A 16 Pin Screw Terminal 17-32	015670	1	
39	Decal, Connector ID P2B	038418	1	
	HARNESS ASSEMBLY, LT70 REMOTE HYDRAULIC JOYSTICK	050965 ¹	1	
40	Connector, 32 Pin Hood Dual Lever	050819	1	
41	Insert, Female 10A 16 Pin Screw Terminal 1-16	E23106	1	
42	Insert, Female 10A 16 Pin Screw Terminal 17-32	015671	1	
43	Decal, Connector ID P3A	038414	1	
44	Connector, Flex Strain .53 - .75 Cord 3/4" Hub	025186	1	
45	STAND WELDMENT, REMOTE CONTROL	034652	1	
46	SPRING, .72" X 1.5" X .067" STAINLESS STEEL COMPRESSION	P04282	2	
47	KNOB WELDMENT, LOCK	034658	2	
	MOUNT ASSEMBLY, LT70 REMOTE CONTROL BOX STORAGE	036167 ²	1	

Control & Battery Boxes

Control Assembly (DC)

5

48	Bracket Weldment, Remote Box Storage	017862	1	
49	Bolt, 3/8-16 x 5 1/2" Hex Head Full Thread	F05007-34	4	
50	Washer, 3/8" SAE Flat	F05011-3	8	
51	Plate, Mount Strap	017818	2	
52	Nut, 3/8-16 Hex Nylon Lock	F05010-10	4	

¹ 16-Pin Harness Connector Housing 015658 and 32-Pin Connector Housing 050819 replaced with 90° connectors ([See Section 5.1](#)).

² Mount Assembly 036167 includes modified Bracket Weldment 017862 and hardware to mount bracket on 4x4 frame tube rather than previous location on main frame tube. Old location interfered with pivot rail (Rev. A1.07).

5.3 Control Assembly (DC)

LT70HD Remote

Rev. A1.00 - A1.08

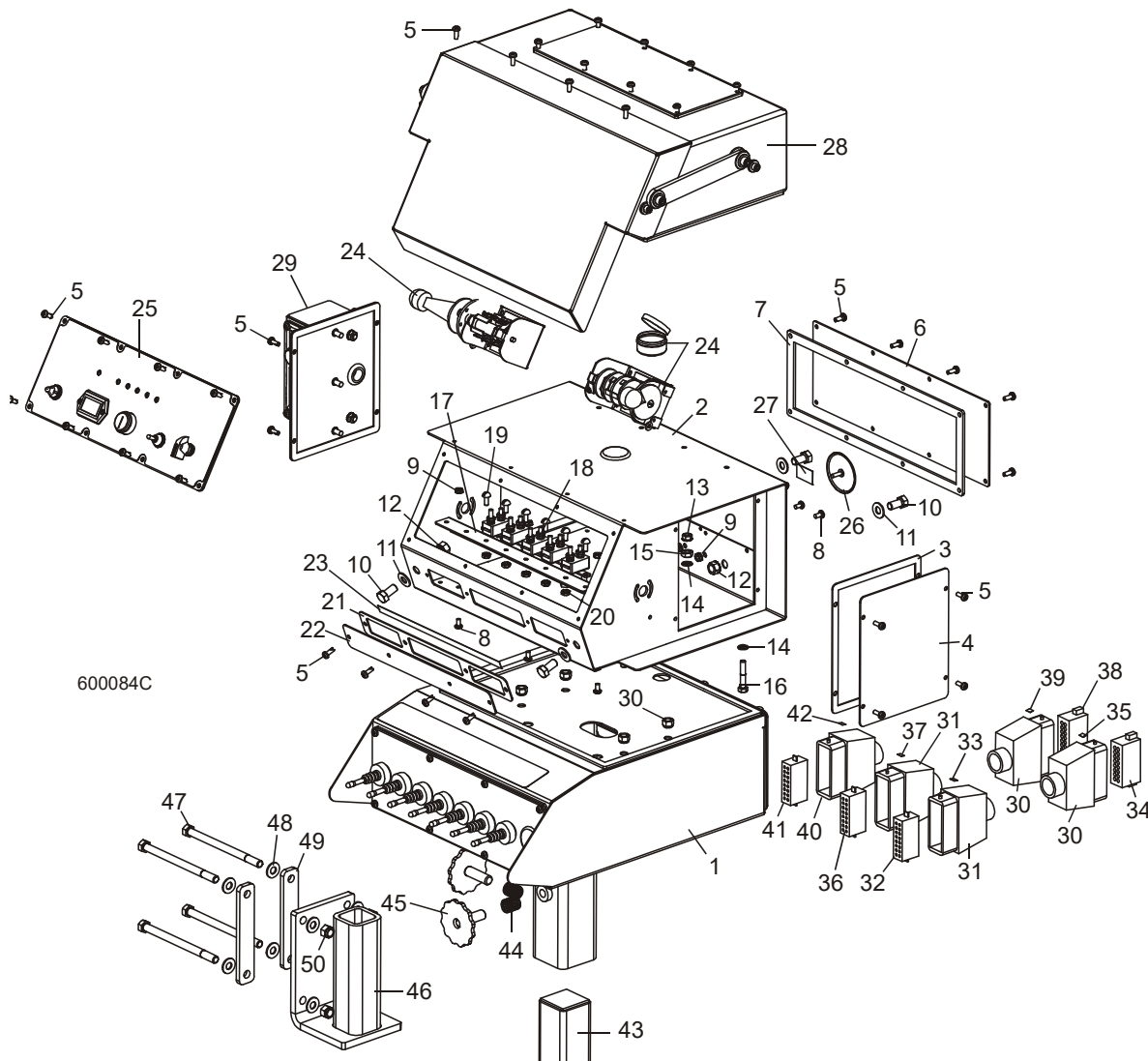

REF	DESCRIPTION (◆ Indicates Parts Available In Assemblies Only)	PART #	QTY.	
	COVER, LT70HD REMOTE CONTROL COVER	036352	1	
	CONTROL BOX ASSEMBLY, LT70HD D42-R	050263 ¹	1	
1	Remote Hydraulic Control Parts (See Section 10.3)			
2	Box Weldment, Control	016135	1	◆
3	Gasket, Side Panel Control 97	015274	1	
4	Panel Weldment, Side	015307	1	
5	Screw, #10-24 x 1/2" Pan Head	F05015-17	32	
6	Panel, Rear Mill Control 97	016230	1	

7	Gasket, Rear Panel 97	015278	1	
8	Screw, 10-24 x 3/8" Phillips Pan Head Machine	F05004-3	5	
9	Nut, #10-24 Self-Locking	F05010-14	5	
10	Bolt, 3/8-16 x 3/4" Hex Head	F05007-27	4	
11	Washer, 3/8" Flat	F05011-3	4	
12	Nut, 3/8-16 Self-Locking	F05010-19	4	
13	Nut, 1/4-20 Self-Locking	F05010-9	1	
14	Washer, 1/4" Interior Star Lock (Heavy Duty)	F05011-69	2	
15	Nut, 1/4-20 Hex Jam (Heavy Duty)	F05010-129	1	
16	Bolt, 1/4-20 x 1 1/2" Hex Head Full Thread	F05005-31	1	
	Breaker Assembly, Remote Control Front	015621	1	
17	Rail, Circuit Breaker	015310	1	
18	Breaker, 15Amp Auto Reset	E20430	5	
19	Screw, #8-32 x 1/2" Slotted Head	F05004-12	10	
20	Nut, #8-32 Hex Self-Locking	F05010-41	10	
21	Gasket, Circuit Breaker Cover	015266	1	
22	Panel, Circuit Breaker Cover	015376	1	
23	Decal, Circuit Breaker Remote Control 97	024363	1	
24	Drum Switch Parts (See Section 5.7)			
25	Control Panel Parts (See Section 5.8)			
26	Plug, AS125 Oil Tight Painted	015673	1	
27	Decal, Circuit Breaker ID (Debarker In/Out)	024364	1	
28	Accuset Parts (See Accuset Manual)			
29	LubeMizer Parts (See LubeMizer Manual)			
30	Nut, 5/16-18 Nylon Lock	F05010-58	4	
	HARNES ASSEMBLY, LT70D42-R/D62-R CONTROL	050742 ²	1	
31	Connector, 16 Pin Hood Single Lever	015658	4	
32	Insert, Female 10A 16 Pin Screw Terminal 1-16	E23106	1	
33	Decal, Connector ID P1A	038412	1	
34	Insert, Male 10A 16 Pin Screw Terminal 1-16	E23105	1	
35	Decal, Connector ID P1B	038417	1	
36	Insert, Female 10A 16 Pin Screw Terminal 17-32	015671	1	
37	Decal, Connector ID P2A	038413	1	
38	Insert, Male 10A 16 Pin Screw Terminal 17-32	015670	1	
39	Decal, Connector ID P2B	038418	1	
	HARNES ASSEMBLY, LT70 REMOTE HYDRAULIC JOYSTICK	050777 ¹	1	
40	Connector, 16 Pin Hood Single Lever	015658	1	
41	Insert, Female 10A 16 Pin Screw Terminal 1-16	E23106	1	
42	Decal, Connector ID P3A	038414	1	
43	STAND WELDMENT, REMOTE CONTROL	034652	1	
44	SPRING, .72" X 1.5" X .067" STAINLESS STEEL COMPRESSION	P04282	2	
45	KNOB WELDMENT, LOCK	034658	2	
	MOUNT ASSEMBLY, LT70 REMOTE CONTROL BOX STORAGE	036167 ³	1	

5 Control & Battery Boxes

Control Assembly (DC)

46	Bracket Weldment, Remote Box Storage	017862	1	
47	Bolt, 3/8-16 x 5 1/2" Hex Head Full Thread	F05007-34	4	
48	Washer, 3/8" SAE Flat	F05011-3	8	
49	Plate, Mount Strap	017818	2	
50	Nut, 3/8-16 Hex Nylon Lock	F05010-10	4	

¹ Control Box 050263 replaced with 050960. Joystick Harness 050777 replaced with dual-connector harness 050965 to accommodate Log Deck option (Rev. A1.09 - [See Section 5.2](#)).

² 16-Pin Harness Connector Housing 015658 with 90° connectors ([See Section 5.1](#)).

³ Mount Assembly 036167 includes modified Bracket Weldment 017862 and hardware to mount bracket on 4x4 frame tube rather than previous location on main frame tube. Old location interfered with pivot rail (Rev. A1.07).

5.4 Control Assembly (AC)

LT70HD Remote

Rev. A2.02 - A3.00

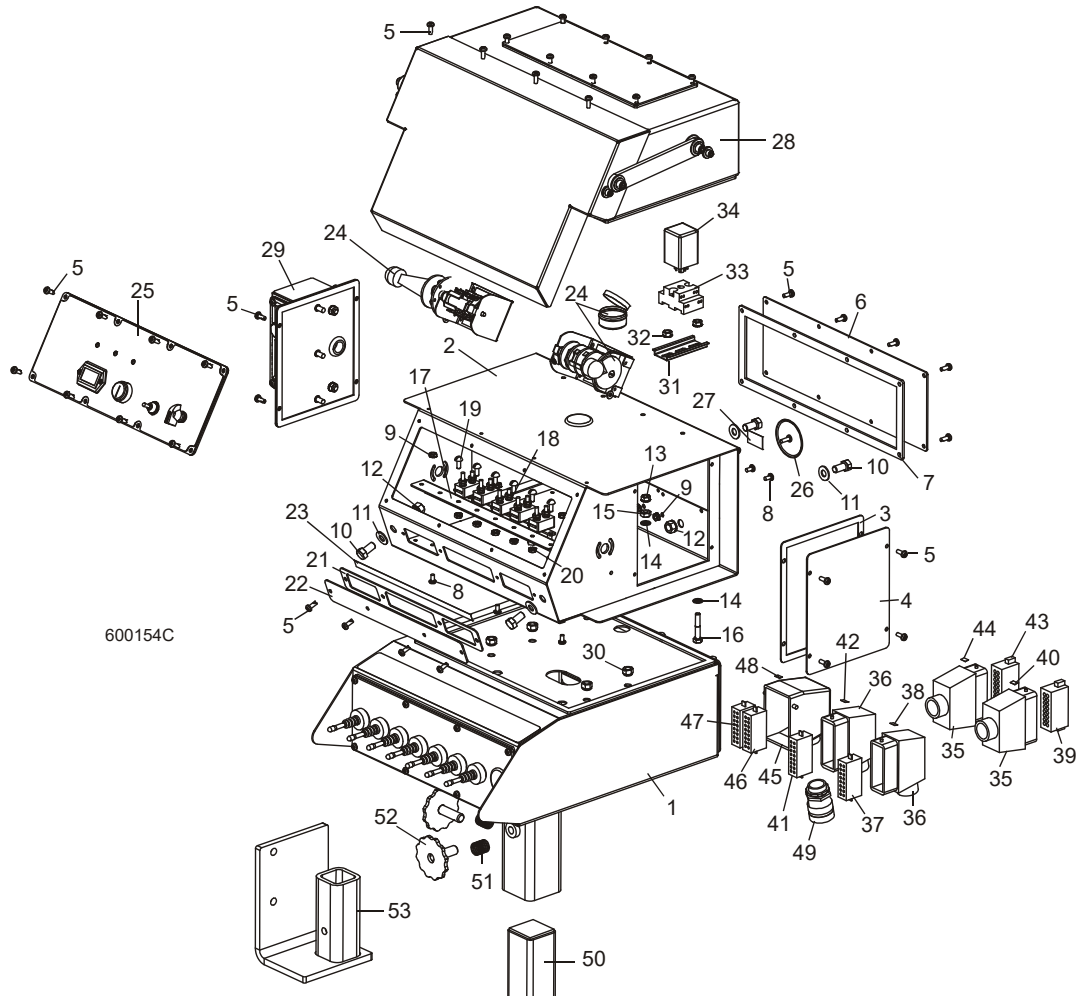

REF	DESCRIPTION (◆ Indicates Parts Available In Assemblies Only)	PART #	QTY.	
	COVER, LT70HD REMOTE CONTROL COVER	036352	1	
	CONTROL BOX ASSEMBLY, LT70HD E25-R	050961	1	
1	Remote Hydraulic Control Parts (See Section 10.2)			
2	Box Weldment, Control	016135	1	◆
3	Gasket, Side Panel Control 97	015274	1	
4	Panel Weldment, Side	015307	1	
5	Screw, #10-24 x 1/2" Pan Head	F05015-17	32	
6	Panel, Rear Mill Control 97	016230	1	
7	Gasket, Rear Panel 97	015278	1	
8	Screw, 10-24 x 3/8" Phillips Pan Head Machine	F05004-3	5	
9	Nut, #10-24 Self-Locking	F05010-14	5	
10	Bolt, 3/8-16 x 3/4" Hex Head	F05007-27	4	

5 Control & Battery Boxes

Control Assembly (AC)

11	Washer, 3/8" Flat	F05011-3	4	
12	Nut, 3/8-16 Self-Locking	F05010-19	4	
13	Nut, 1/4-20 Self-Locking	F05010-9	1	
14	Washer, 1/4" Interior Star Lock (Heavy Duty)	F05011-69	2	
15	Nut, 1/4-20 Hex Jam (Heavy Duty)	F05010-129	1	
16	Bolt, 1/4-20 x 1 1/2" Hex Head Full Thread	F05005-31	1	
	Breaker Assembly, Remote AC Control Front	050916	1	
17	Rail, Circuit Breaker	015310	1	
18	Breaker, 15Amp Auto Reset	E20430	5	
19	Screw, #8-32 x 1/2" Slotted Head	F05004-12	6	
20	Nut, #8-32 Hex Self-Locking	F05010-41	6	
21	Gasket, Circuit Breaker Cover	015266	1	
22	Panel, Circuit Breaker Cover	015376	1	
23	Decal, Circuit Breaker LT60/70 AC	050917	1	
24	Drum Switch Parts (See Section 5.7)			
25	Control Panel Parts (See Section 5.8)			
26	Plug, AS125 Oil Tight Painted	015673	1	
27	Decal, Circuit Breaker ID (Debarker In/Out)	050918	1	
28	Accuset Parts (See Remote Accuset Manual)			
29	LubeMizer Parts (See LubeMizer Manual)			
30	Nut, 5/16-18 Nylon Lock	F05010-58	4	
31	Rail, 35mm x 7.5mm x 3" Steel DIN	024474-3	1	
32	Nut, 1/4-20 Self-Locking	F05010-9	2	
33	Socket, 8 Pin Relay	E10216	1	
34	Relay, DPDT 10A GP Tube Terminals	050300	1	
	HARNES ASSEMBLY, LT70E25-R CONTROL	050743 ¹	1	
35	Connector, 16 Pin Hood Single Lever	015658	2	
36	Connector, 16 Pin Hood Single Lever 90°	051499 ¹	2	
37	Insert, Female 10A 16 Pin Screw Terminal 1-16	E23106	1	
38	Decal, Connector ID P1A	038412	1	
39	Insert, Male 10A 16 Pin Screw Terminal 1-16	E23105	1	
40	Decal, Connector ID P1B	038417	1	
41	Insert, Female 10A 16 Pin Screw Terminal 17-32	015671	1	
42	Decal, Connector ID P2A	038413	1	
43	Insert, Male 10A 16 Pin Screw Terminal 17-32	015670	1	
44	Decal, Connector ID P2B	038418	1	
	HARNES ASSEMBLY, LT70 REMOTE HYDRAULIC JOYSTICK	050965 ¹	1	
45	Connector, 32 Pin Hood Dual Lever 90°	051500 ¹	1	
46	Insert, Female 10A 16 Pin Screw Terminal 1-16	E23106	1	
47	Insert, Female 10A 16 Pin Screw Terminal 17-32	015671	1	
48	Decal, Connector ID P3A	038414	1	
49	Connector, Flex Strain .53 - .75 Cord 3/4" Hub	025186	1	
50	STAND WELDMENT, REMOTE CONTROL	034652	1	

Control & Battery Boxes

Control Assembly (AC)

5

51	SPRING, .72" X 1.5" X .067" STAINLESS STEEL COMPRESSION	P04282	2	
52	KNOB WELDMENT, LOCK	034658	2	
53	MOUNT WELDMENT, LT70 REMOTE CONTROL BOX STORAGE	046443 ²	1	

¹ 16-Pin Harness Connector Housing 015658 and 32-Pin Connector Housing 050819 replaced with 90° connectors (Rev A3.00).

² New storage bracket 046443 replaces storage bracket assembly 036167 to accommodate new board return table (Rev. A2.02).

5.5 Control Assembly (AC)

LT70HD Remote

Rev. A1.09 - A2.01

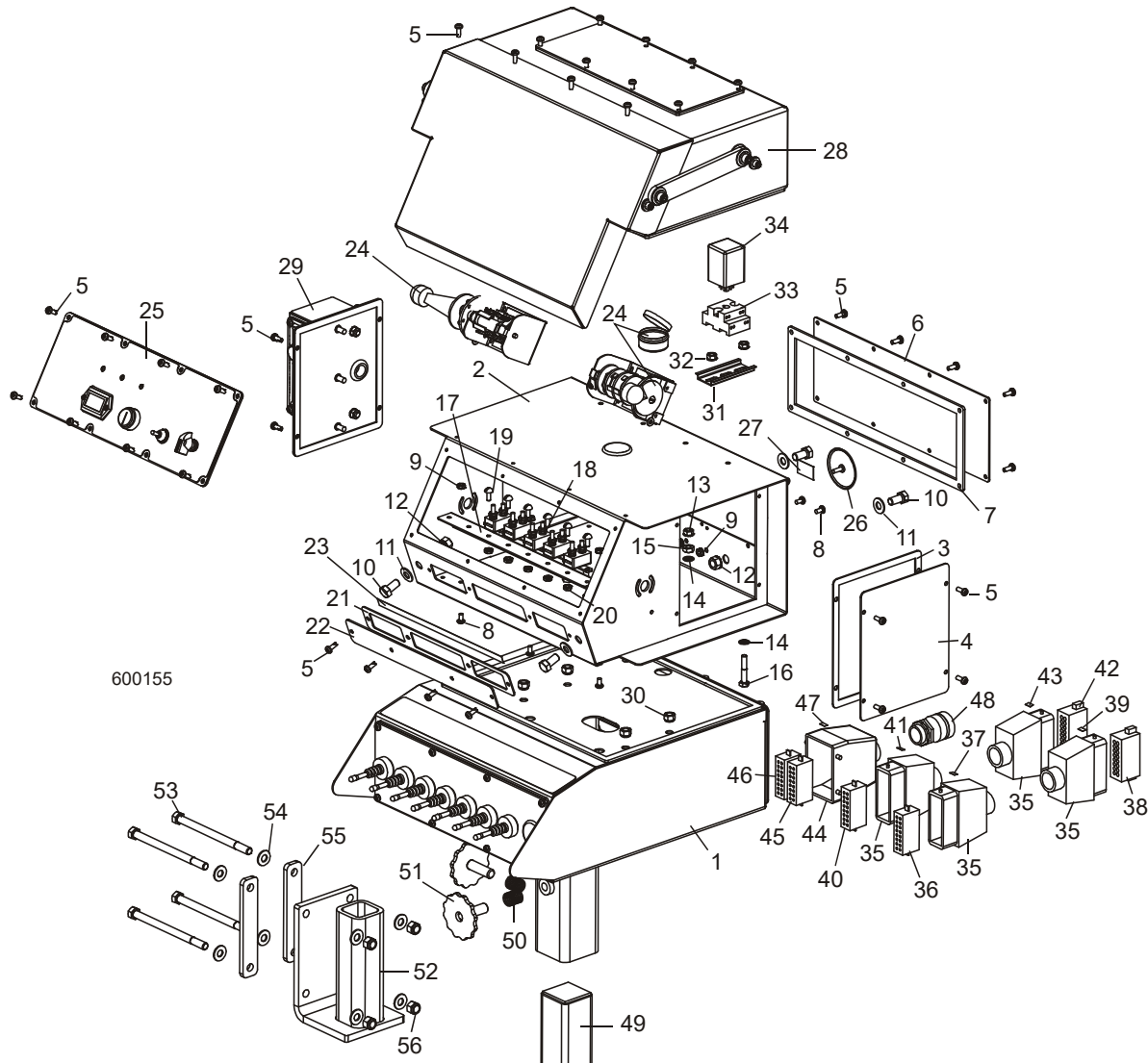

REF	DESCRIPTION (◆ Indicates Parts Available In Assemblies Only)	PART #	QTY.	
	COVER, LT70HD REMOTE CONTROL COVER	036352	1	
	CONTROL BOX ASSEMBLY, LT70HD E25-R	050961	1	
1	Remote Hydraulic Control Parts (See Section 10.2)			
2	Box Weldment, Control	016135	1	◆
3	Gasket, Side Panel Control 97	015274	1	
4	Panel Weldment, Side	015307	1	
5	Screw, #10-24 x 1/2" Pan Head	F05015-17	32	
6	Panel, Rear Mill Control 97	016230	1	
7	Gasket, Rear Panel 97	015278	1	

8	Screw, 10-24 x 3/8" Phillips Pan Head Machine	F05004-3	5	
9	Nut, #10-24 Self-Locking	F05010-14	5	
10	Bolt, 3/8-16 x 3/4" Hex Head	F05007-27	4	
11	Washer, 3/8" Flat	F05011-3	4	
12	Nut, 3/8-16 Self-Locking	F05010-19	4	
13	Nut, 1/4-20 Self-Locking	F05010-9	1	
14	Washer, 1/4" Interior Star Lock (Heavy Duty)	F05011-69	2	
15	Nut, 1/4-20 Hex Jam (Heavy Duty)	F05010-129	1	
16	Bolt, 1/4-20 x 1 1/2" Hex Head Full Thread	F05005-31	1	
	Breaker Assembly, Remote AC Control Front	050916	1	
17	Rail, Circuit Breaker	015310	1	
18	Breaker, 15Amp Auto Reset	E20430	5	
19	Screw, #8-32 x 1/2" Slotted Head	F05004-12	6	
20	Nut, #8-32 Hex Self-Locking	F05010-41	6	
21	Gasket, Circuit Breaker Cover	015266	1	
22	Panel, Circuit Breaker Cover	015376	1	
23	Decal, Circuit Breaker LT60/70 AC	050917	1	
24	Drum Switch Parts (See Section 5.7)			
25	Control Panel Parts (See Section 5.8)			
26	Plug, AS125 Oil Tight Painted	015673	1	
27	Decal, Circuit Breaker ID (Debarker In/Out)	050918	1	
28	Accuset Parts (See Remote Accuset Manual)			
29	LubeMizer Parts (See LubeMizer Manual)			
30	Nut, 5/16-18 Nylon Lock	F05010-58	4	
31	Rail, 35mm x 7.5mm x 3" Steel DIN	024474-3	1	
32	Nut, 1/4-20 Self-Locking	F05010-9	2	
33	Socket, 8 Pin Relay	E10216	1	
34	Relay, DPDT 10A GP Tube Terminals	050300	1	
	HARNES ASSEMBLY, LT70E25-R CONTROL	050743 ¹	1	
35	Connector, 16 Pin Hood Single Lever	015658	4	
36	Insert, Female 10A 16 Pin Screw Terminal 1-16	E23106	1	
37	Decal, Connector ID P1A	038412	1	
38	Insert, Male 10A 16 Pin Screw Terminal 1-16	E23105	1	
39	Decal, Connector ID P1B	038417	1	
40	Insert, Female 10A 16 Pin Screw Terminal 17-32	015671	1	
41	Decal, Connector ID P2A	038413	1	
42	Insert, Male 10A 16 Pin Screw Terminal 17-32	015670	1	
43	Decal, Connector ID P2B	038418	1	
	HARNES ASSEMBLY, LT70 REMOTE HYDRAULIC JOYSTICK	050965 ¹	1	
44	Connector, 32 Pin Hood Dual Lever	050819	1	
45	Insert, Female 10A 16 Pin Screw Terminal 1-16	E23106	1	
46	Insert, Female 10A 16 Pin Screw Terminal 17-32	015671	1	
47	Decal, Connector ID P3A	038414	1	

5 Control & Battery Boxes

Control Assembly (AC)

48	Connector, Flex Strain .53 - .75 Cord 3/4" Hub	025186	1	
49	STAND WELDMENT, REMOTE CONTROL	034652	1	
50	SPRING, .72" X 1.5" X .067" STAINLESS STEEL COMPRESSION	P04282	2	
51	KNOB WELDMENT, LOCK	034658	2	
	MOUNT ASSEMBLY, LT70 REMOTE CONTROL BOX STORAGE	036167	1	
52	Bracket Weldment, Remote Box Storage	017862	1	
53	Bolt, 3/8-16 x 5 1/2" Hex Head Full Thread	F05007-34	4	
54	Washer, 3/8" SAE Flat	F05011-3	8	
55	Plate, Mount Strap	017818	2	
56	Nut, 3/8-16 Hex Nylon Lock	F05010-10	4	

¹ 16-Pin Harness Connector Housing 015658 and 32-Pin Connector Housing 050819 replaced with 90° connectors ([See Section 5.4](#)).

5.6 Control Assembly (AC)

LT70HD Remote

Rev. A1.00 - A1.08

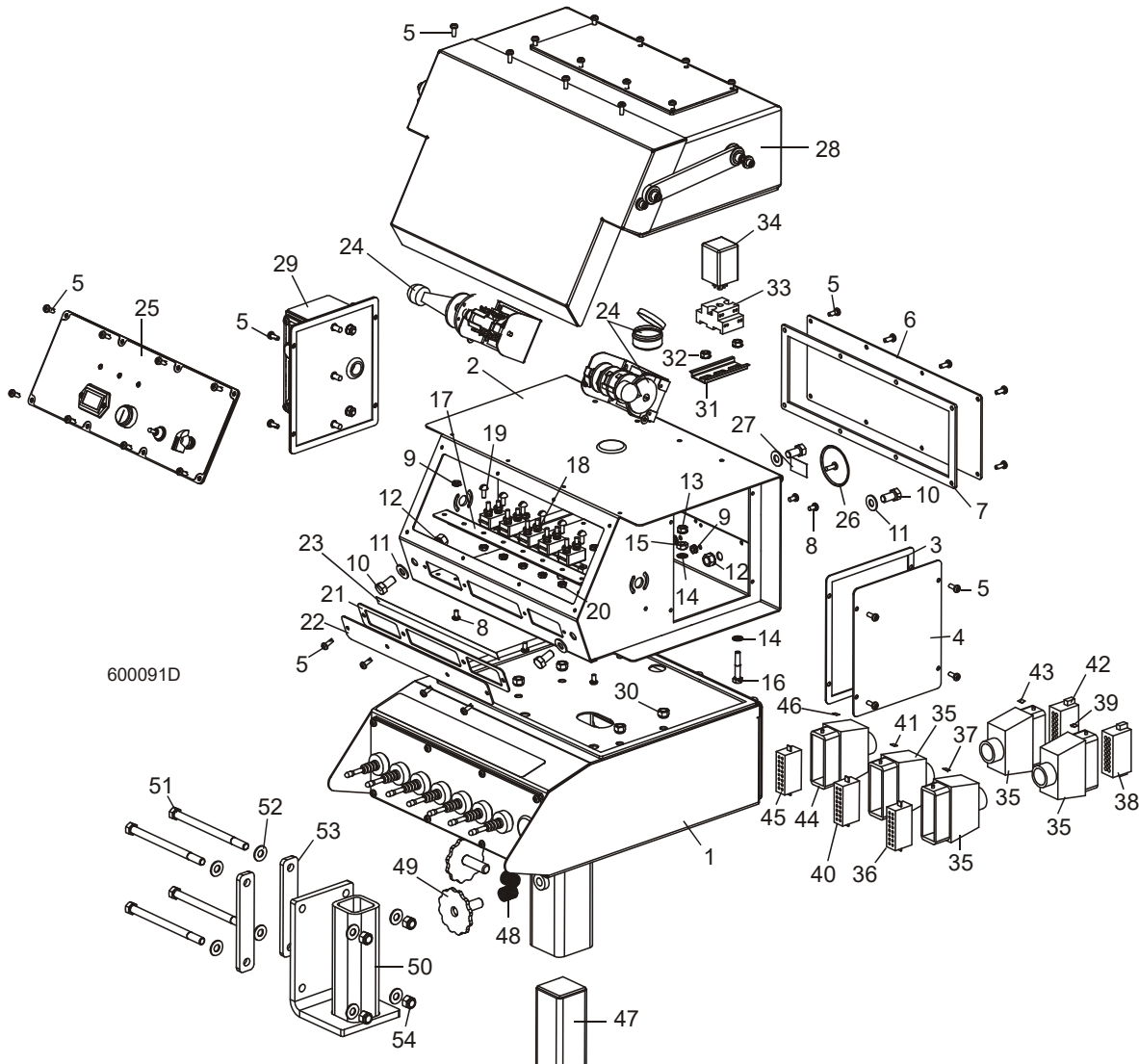

REF	DESCRIPTION (◆ Indicates Parts Available In Assemblies Only)	PART #	QTY.	
	COVER, LT70HD REMOTE CONTROL COVER	036352	1	
	CONTROL BOX ASSEMBLY, LT70HD E25-R	050264 ¹	1	
1	Remote Hydraulic Control Parts (See Section 10.3)			
2	Box Weldment, Control	016135	1	◆
3	Gasket, Side Panel Control 97	015274	1	
4	Panel Weldment, Side	015307	1	
5	Screw, #10-24 x 1/2" Pan Head	F05015-17	32	
6	Panel, Rear Mill Control 97	016230	1	

5 Control & Battery Boxes

Control Assembly (AC)

7	Gasket, Rear Panel 97	015278	1	
8	Screw, 10-24 x 3/8" Phillips Pan Head Machine	F05004-3	5	
9	Nut, #10-24 Self-Locking	F05010-14	5	
10	Bolt, 3/8-16 x 3/4" Hex Head	F05007-27	4	
11	Washer, 3/8" Flat	F05011-3	4	
12	Nut, 3/8-16 Self-Locking	F05010-19	4	
13	Nut, 1/4-20 Self-Locking	F05010-9	1	
14	Washer, 1/4" Interior Star Lock (Heavy Duty)	F05011-69	2	
15	Nut, 1/4-20 Hex Jam (Heavy Duty)	F05010-129	1	
16	Bolt, 1/4-20 x 1 1/2" Hex Head Full Thread	F05005-31	1	
	Breaker Assembly, Remote AC Control Front	050916	1	
17	Rail, Circuit Breaker	015310	1	
18	Breaker, 15Amp Auto Reset	E20430	5	
19	Screw, #8-32 x 1/2" Slotted Head	F05004-12	6	
20	Nut, #8-32 Hex Self-Locking	F05010-41	6	
21	Gasket, Circuit Breaker Cover	015266	1	
22	Panel, Circuit Breaker Cover	015376	1	
23	Decal, Circuit Breaker LT60/70 AC	050917	1	
24	Drum Switch Parts (See Section 5.7)			
25	Control Panel Parts (See Section 5.8)			
26	Plug, AS125 Oil Tight Painted	015673	1	
27	Decal, Circuit Breaker ID (Debarker In/Out)	050918	1	
28	Accuset Parts (See Remote Accuset Manual)			
29	LubeMizer Parts (See LubeMizer Manual)			
30	Nut, 5/16-18 Nylon Lock	F05010-58	4	
31	Rail, 35mm x 7.5mm x 3" Steel DIN	024474-3	1	
32	Nut, 1/4-20 Self-Locking	F05010-9	2	
33	Socket, 8 Pin Relay	E10216	1	
34	Relay, DPDT 10A GP Tube Terminals	050300	1	
	HARNESS ASSEMBLY, LT70E25-R CONTROL	050743 ²	1	
35	Connector, 16 Pin Hood Single Lever	015658	4	
36	Insert, Female 10A 16 Pin Screw Terminal 1-16	E23106	1	
37	Decal, Connector ID P1A	038412	1	
38	Insert, Male 10A 16 Pin Screw Terminal 1-16	E23105	1	
39	Decal, Connector ID P1B	038417	1	
40	Insert, Female 10A 16 Pin Screw Terminal 17-32	015671	1	
41	Decal, Connector ID P2A	038413	1	
42	Insert, Male 10A 16 Pin Screw Terminal 17-32	015670	1	
43	Decal, Connector ID P2B	038418	1	
	HARNESS ASSEMBLY, LT70 REMOTE HYDRAULIC JOYSTICK	050777 ¹	1	
44	Connector, 16 Pin Hood Single Lever	015658	1	
45	Insert, Female 10A 16 Pin Screw Terminal 1-16	E23106	1	
46	Decal, Connector ID P3A	038414	1	

47	STAND WELDMENT, REMOTE CONTROL	034652	1	
48	SPRING, .72" X 1.5" X .067" STAINLESS STEEL COMPRESSION	P04282	2	
49	KNOB WELDMENT, LOCK	034658	2	
	MOUNT ASSEMBLY, LT70 REMOTE CONTROL BOX STORAGE	036167 ³	1	
50	Bracket Weldment, Remote Box Storage	017862	1	
51	Bolt, 3/8-16 x 5 1/2" Hex Head Full Thread	F05007-34	4	
52	Washer, 3/8" SAE Flat	F05011-3	8	
53	Plate, Mount Strap	017818	2	
54	Nut, 3/8-16 Hex Nylon Lock	F05010-10	4	

¹ Control Box 050264 replaced with 050961. Joystick Harness 050777 replaced with dual-connector harness 050965 to accommodate Log Deck option (Rev. A1.09 - [See Section 5.5](#)).

² 16-Pin Harness Connector Housing 015658 and 32-Pin Connector Housing 050819 replaced with 90° connectors ([See Section 5.4](#)).

³ Mount Assembly 036167 includes modified Bracket Weldment 017862 and hardware to mount bracket on 4x4 frame tube rather than previous location on main frame tube. Old location interfered with pivot rail (Rev. A1.07).

5.7 Drum Switches

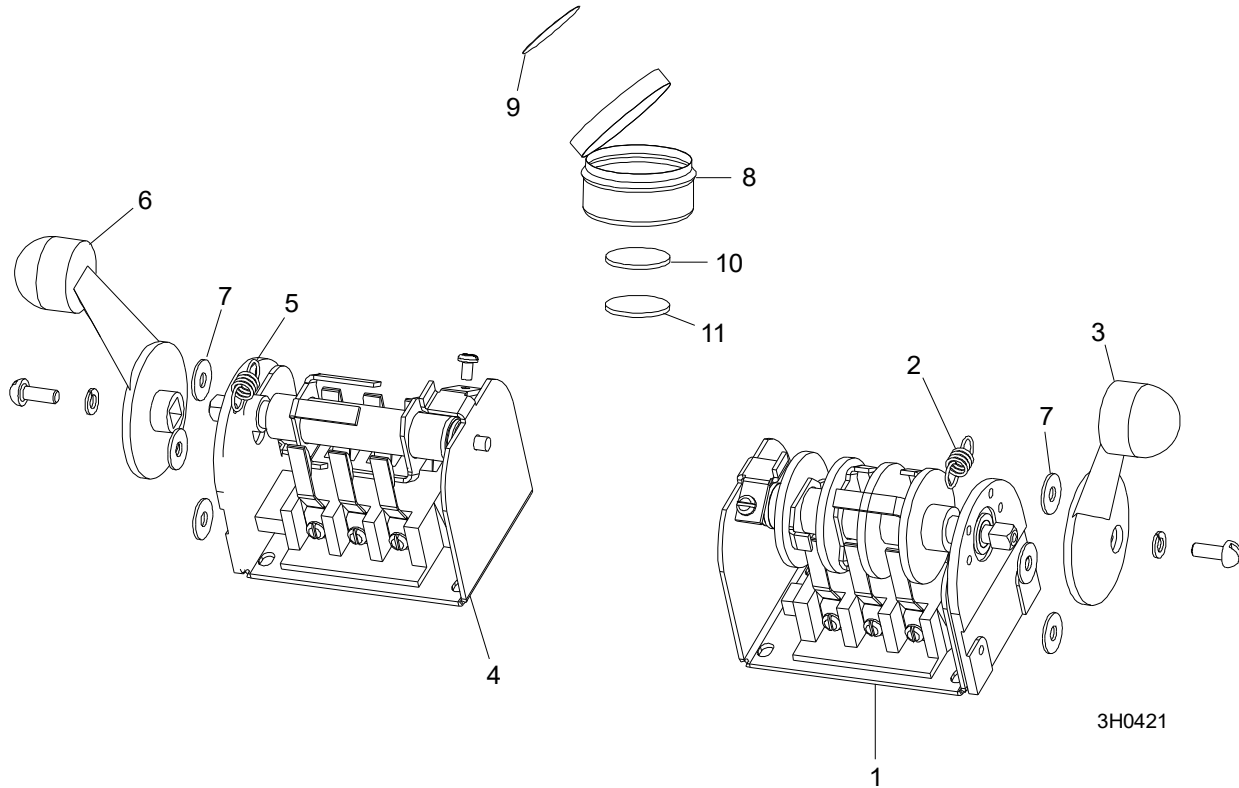

REF	DESCRIPTION (◆ Indicates Parts Available In Assemblies Only)	PART #	QTY.	
	SWITCH ASSEMBLY, UP/DOWN DRUM	E20440	1	
1	Switch, S12 Bulk Drum	E20440-B	1	◆
2	Spring, Drum Switch	P12570	1	
3	Handle, Drum Switch Replacement	P12500	1	
	SWITCH ASSEMBLY, POWER FEED DRUM	E20439	1	
4	Switch, S11 Bulk Drum	E20439-B	1	◆
5	Spring, Drum Switch	P12570	1	
6	Handle, Drum Switch Replacement	P12500	1	
7	WASHER, #8 SAE FLAT	F05011-41	6	
	CUP ASSEMBLY, DRUM SWITCH GREASE	A20463	1	
8	Cup, Plastic Container	P20464	1	◆
9	Decal, Grease Cup Label	P20467	1	
10	Pad, Velcro Loop	P20466	1	◆
11	Pad, Velcro Hook	P20465	1	◆
	Grease, High Temp Drum Switch	P20468	.025 Lb	◆

5.8 Front Panel Assembly

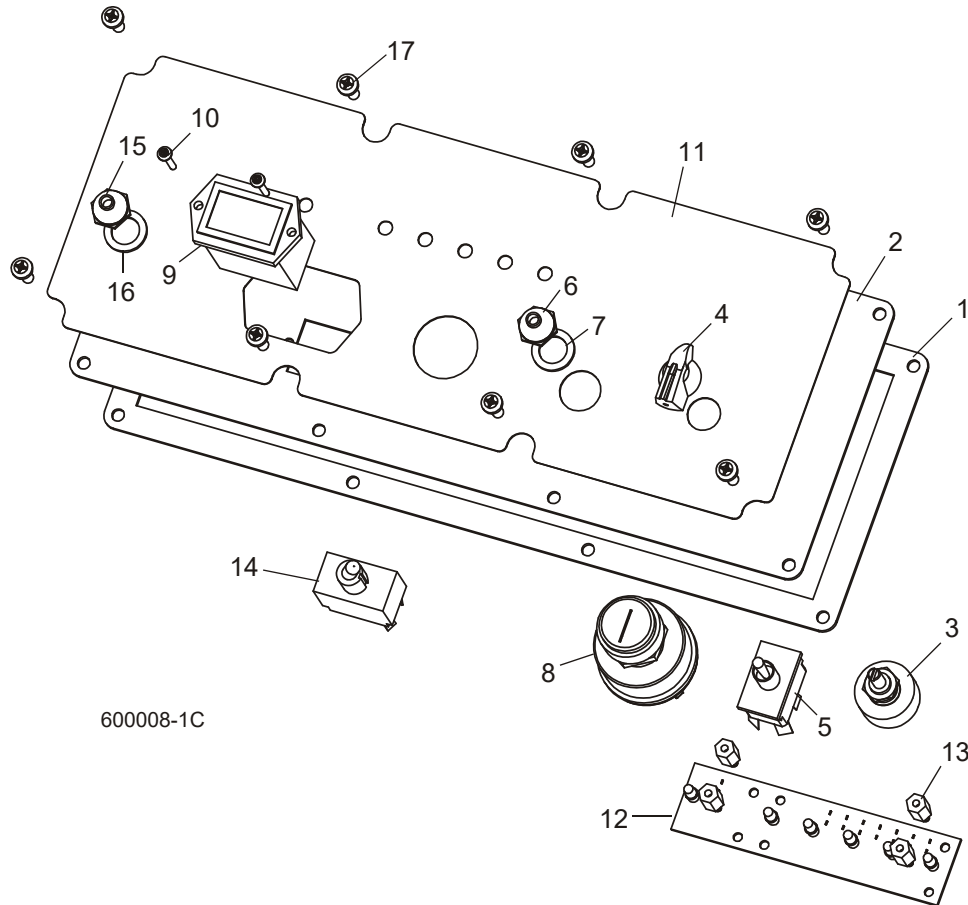

600008-1C

REF	DESCRIPTION (◆ Indicates Parts Available In Assemblies Only)	PART #	QTY.
	PANEL ASSEMBLY, CONTROL FRONT D42/D51/D62 REMOTE	024671	1
	PANEL ASSEMBLY, CONTROL FRONT E25	050299	1
1	Gasket, Front Panel	015270	1
2	Panel Weldment, Control	015302	1
3	Switch Assembly, Feed Rate	024450-1	1
4	Knob, Feed Rate With Set Screw	P06257	1
5	Switch, Toggle	024200	1
6	Boot, Toggle Switch Rubber	P02575	1
7	Washer, 1/2 x 3/4 x 1/16" Nylon	P05251-1	1
8	Switch, Key	P04350	1
9	Meter, Hour	015401	1
10	Screw, 6-42 x 3/4" Socket Button Head Cap Stainless Steel	F05004-93	2
11	Nut, #6-32 Self Locking	F05010-59	2
12	Decal, Control Panel (E25)	015271	1
	Decal, Control Panel (D42/D51/D62)	015269	1

5

Control & Battery Boxes

Front Panel Assembly

13	Board, LED Circuit (E25)	015416	1	
	Board, LED Circuit (D42/D51/D62)	015409	1	
14	Spacer, 1/2"-#6 Threaded	023147	4	
15	Switch, Blade Start/Stop (Diesel Only)	051346 ¹	1	
16	Boot, Toggle Switch Rubber (Diesel Only)	P02575	1	
17	Washer, 1/2 x 3/4 x 1/16" Nylon (Diesel Only)	P05251-1	1	
	Conduit, 1 1/4" x 58" Flex	050399	1	
	Connector, 1 1/4" Straight Male Metal Conduit	024402	1	
	Cable Assembly, AC LT70 Power Feed Service (E25 Only)	052859	1	
18	SCREW, #10-24 X 1/2" PAN HEAD	F05015-17	8	
	CONDUIT, 1 1/4" X 58" FLEX	050399	1	
	CONNECTOR, 1 1/4" STRAIGHT MALE METAL CONDUIT	024402	1	
	CONDUIT, 1/2" EXPANDABLE BLACK	R02374	41 in.	
	CONDUIT, 1/2" EXPANDABLE BLACK	R02374	42 in.	

¹ 051346 On/On Toggle Switch replaces 015665 On/Off/On Toggle Switch supplied before 8/03. Center OFF position not required for Autoclutch operation.

5.9 Battery Box Assembly (DC Only)

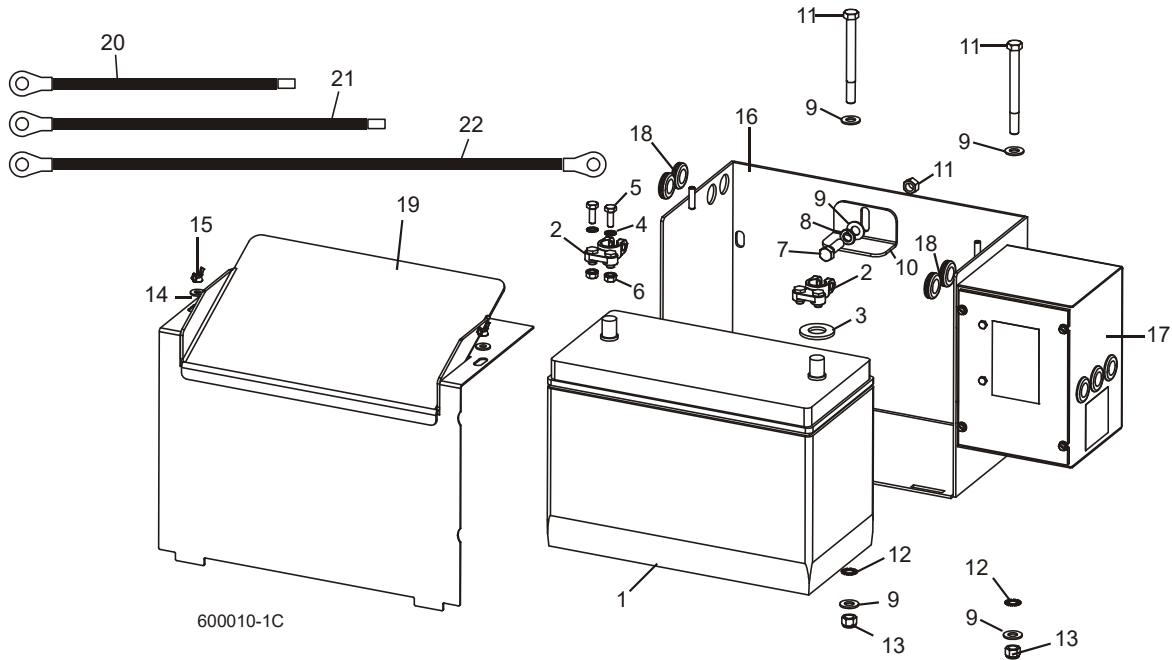

REF	DESCRIPTION (◆ Indicates Parts Available In Assemblies Only)	PART #	QTY.	
1	BATTERY, 12 VOLT C31-1000 ¹	015475	1	◆
	BOX ASSEMBLY, LT70 BATTERY	017674 ²	1	
2	Terminal, Battery	P05085	2	
3	Washer, Battery Terminal	P12161	1	
4	Washer, 1/4" Exterior Star Lock	F05011-37	2	
5	Bolt, 1/4-20 x 3/4" Hex Head Full Thread	F05005-1	2	
6	Nut, 1/4-20 Self-Locking Hex	F05010-9	2	
7	Bolt, 3/8-16 x 1 1/4" Hex Head	F05007-2	1	
8	Washer, 3/8" Split Lock	F05011-4	1	
9	Washer, 3/8" SAE Flat	F05011-3	5	
10	Bracket, Battery Hold-Down	017725	1	
11	Nut, 3/8-16 Hex Lock	F05010-25		
12	Washer, 3/8" External Star	F05011-36	2	
13	Nut, 3/8" Hex Nylon Lock	F05010-10	2	
14	Washer, 1/4" SAE Flat	F05011-11	2	
15	Nut, 1/4-20 Wing	F05010-13	2	
16	Box Weldment, Battery	015191	1	
17	Fuse Box Parts (See Section 5.10)			
18	Grommet, 5/8" Rubber Wire	P11764	4	

5 Control & Battery Boxes

Battery Box Assembly (DC Only)

19	LID WELDMENT, BATTERY BOX	033976	1	
20	CABLE ASSEMBLY, 1 GA X 12" 150A FUSE TO BATTERY POSITIVE	036308	1	
21	CABLE ASSEMBLY, 1 GA X 16" 225A FUSE TO BATTERY POSITIVE	036309	1	
22	CABLE ASSEMBLY, 1 GA X 26" BATTERY NEGATIVE TO NEG. CONTACT	036306 ³	1	

¹ Replaces Deka 1231PMF supplied prior to 1/05

² Battery Box Assembly 017674 modified to include new fuse block and mega fuses 1/09 ([See Section 5.10](#)).

³ Replaces 024676 originally supplied (duplicate parts).

5.10 Fuse Box Assembly (DC Only)

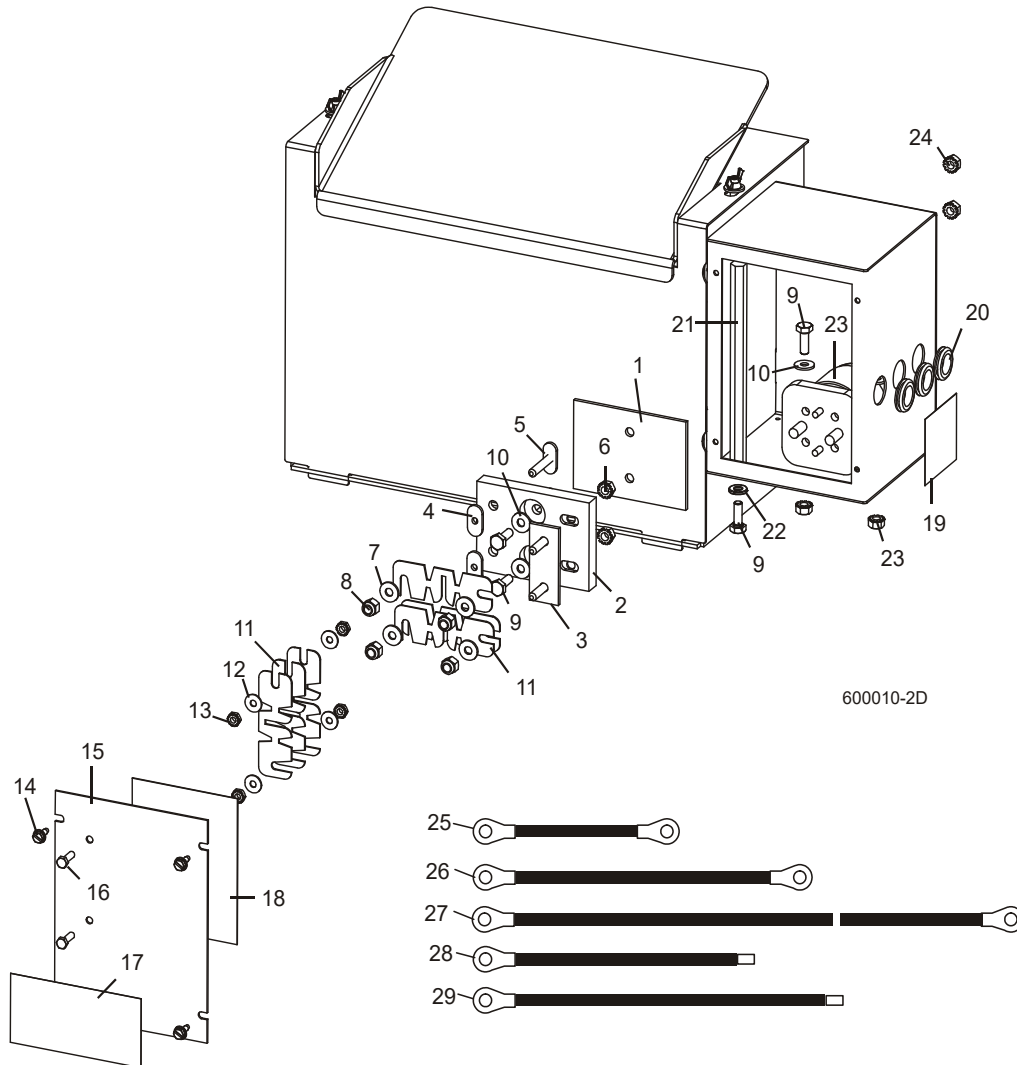

REF	DESCRIPTION (◆ Indicates Parts Available In Assemblies Only)	PART #	QTY.	
1	PAD, FUSE BOX INSULATOR	015287	1	
	FUSE BLOCK ASSEMBLY	017665 ¹	1	
2	Block, Fuse Mount	017664	1	◆
3	Post Weldment, Fuse Mount	017663	1	
4	Nut, 1/4-20 Cadmium Plated Weld	S12392	2	
5	Stud Weldment, 1/4-20 Fuse	W12389	2	
6	Nut, 1/4-20 Self-Locking Hex	F05010-9	2	
7	Washer, 1/4" SAE Flat	F05011-11	4	
8	Nut, 1/4-20 Hex Lock	F05010-21 ²	4	
9	BOLT, 1/4-20 X 3/4" HEX HEAD FULL THREAD	F05005-1	5	

5

Control & Battery Boxes

Fuse Box Assembly (DC Only)

10	WASHER, 1/4" SAE FLAT	F05011-11	4	
11	FUSE LINK, 12 VOLT 225 AMP	P11550	6	
12	WASHER, #10 SAE FLAT	F05011-18	4	
13	NUT, #10-24 HEX SELF-LOCKING	F05010-14	4	
14	SCREW, #10-24 X 1/2" SELF-TAPPING	F05015-7	4	
15	COVER, FUSE BOX	015282	1	
16	SCREW, #10-24 X 5/8" HEX HEAD	F05004-18	2	
17	DECAL, 12 VOLT WARNING	P10364	1	
18	DECAL, FUSE LINK I.D. LT70	017681	1	
19	DECAL, HYDRAULIC CONTACT CAUTION	P12960	1	
20	GROMMET, 5/8" RUBBER WIRE	P11764	3	
21	TERMINAL, EXTENDED HEX STUD	015517	1	
22	WASHER, 1/4" SPLIT LOCK	F05011-14	1	
23	SOLENOID, 200A 12V SPST CONT. DUTY	016371	1	
	Solenoid, 200A 12V SPST Cont. Duty	015470	1	◆
	Diode Assembly, Solenoid Coil Chassis Gnd	015426 ³	1	
	WIRE ASSEMBLY, HYDRAULIC SOLENOID VOLTAGE DROP	024451	1	
24	NUT, 1/4-20 SELF-LOCKING HEX	F05010-9	4	
25	CABLE ASSEMBLY, 1 GA X 6 1/2" FUSE TO SOLENOID	036305	1	
26	CABLE ASSEMBLY, 1 GA X 14" SOLENOID TO POSITIVE CONTACT	036307	1	
27	CABLE ASSEMBLY, 1 GA X 26" BATT. NEGATIVE TO GROUND CONTACT	036306	1	
28	CABLE ASSEMBLY, 1 GA X 12" 150A FUSE TO BATTERY POSITIVE	036308	1	
29	CABLE ASSEMBLY, 1 GA X 16" 225A FUSE TO BATTERY POSITIVE	036309	1	

¹ Battery Box Assembly modified to include new fuse block and mega fuse 1/09. Use kit 006906 to retrofit (requires one 225A Mega-Fuse 053339 and one 450A Mega-Fuse 053340 sold separately).

² Swaged lock nut F05010-21 replaces Nylon Lock Nut F05010-69 originally supplied prior to 7/08. Heat from the fuses can cause the nylon to melt and the nut to come loose. Nuts and washers added to fuse block kit 017665 11/08.

³ Diode Assembly 015426 added to prevent damage to hydraulic microswitch (8/04).

5.11 Remote Power Box Assembly (DC)

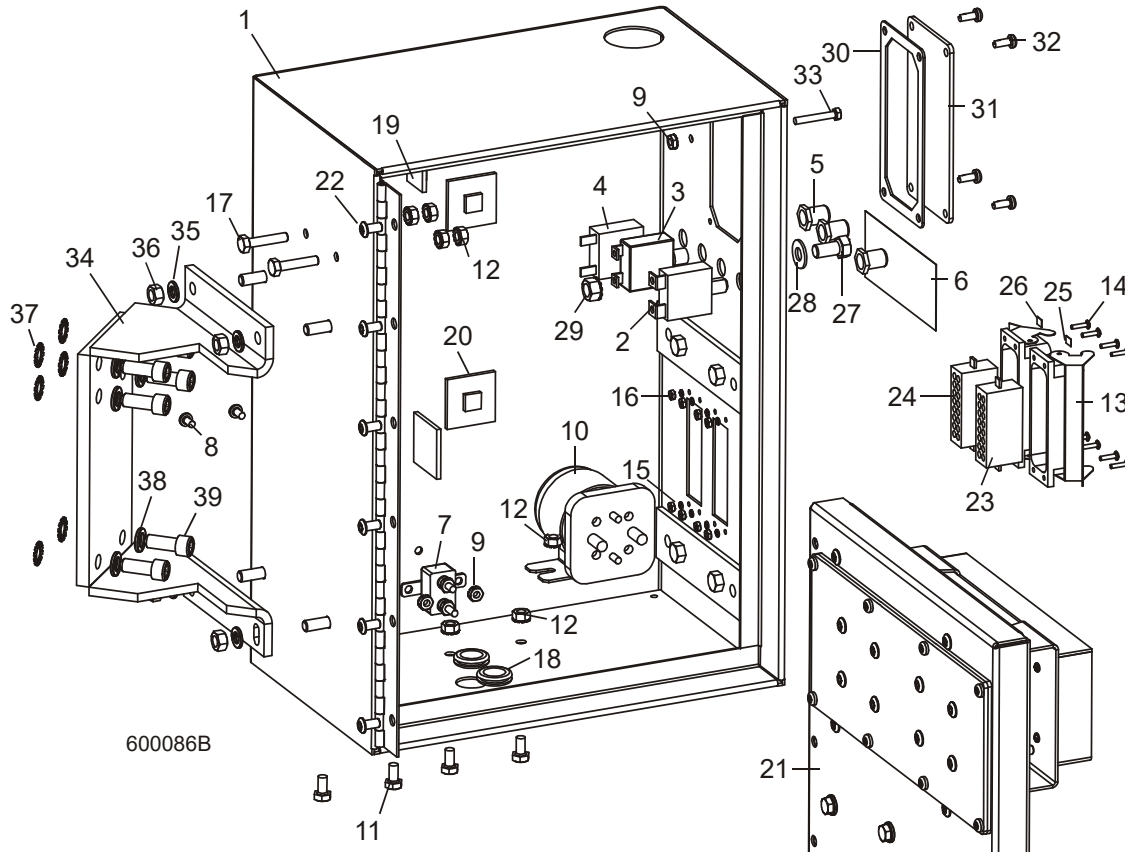

REF	DESCRIPTION (◆ Indicates Parts Available In Assemblies Only)	PART #	QTY.
	BOX ASSEMBLY, D42 REMOTE POWER W/ACCUSSET	050265	1
	BOX ASSEMBLY, D62 REMOTE POWER W/ACCUSSET	051276	1
1	Box Weldment, Remote Power	050278	1
2	Breaker, 30A Manual Reset Panel Mount	024246	1
3	Breaker, 70A Manual Reset Panel Mount	015527 ¹	1
4	Breaker, 70A Manual Reset Panel Mount	015527	1
5	Boot, Circuit Breaker	021253	3
6	Decal, Super Remote Circuit Breaker ID	024430	1
7	Breaker, 30A Manual Reset	E20431	1
8	Screw, #10-24 x 3/8" Cross-Slotted Pan Head	F05004-3	2
9	Nut, #10-24 Self-Locking Hex	F05010-14	3
10	Solenoid Kit, 200A Accessory Upgrade	052387 ²	1
	Solenoid Kit, 200A Replacement	016371	1
	Solenoid, 200A 12V SPST Cont. Duty	015470	1
	Diode Assembly, Solenoid Coil Chassis Gnd	015426	1
11	Bolt, 1/4-20 x 1/2" Hex Head	F05005-15	4

5

Control & Battery Boxes

Remote Power Box Assembly (DC)

12	Nut, 1/4-20 Self-Locking Hex	F05010-9	8	
13	Connector, 16-Pin Panel Mount Single Lever	E23103	2	
14	Screw, #4-40 x 1/2" Slotted Round Head	F05004-14	8	
15	Washer, #4 Split Lock	F05011-21	8	
16	Nut, #4-40 Hex	F05010-43	8	
17	Bolt, 1/4-20 x 1 1/4" Hex Head	F05005-3	2	
18	Grommet, 5/8" I.D. Rubber	P11764	2	
19	Clip, Adhesive-Backed Wire Anchor	F05089-4	1	
20	Clip, Adhesive-Backed Wire Anchor	F05089-7	3	
21	Door Parts (See Section 5.13)			
22	Bolt, 1/4-20 x 1/2" Button Socket Head	F05005-112	6	
	Harness Assembly, Remote Power Box 1-16	050781	1	
23	Insert, Female 10A 16P Scr. Term. 1-16	E23106	1	
	Harness Assembly, Remote Power Box 17-32	050782	1	
24	Insert, Female 10A 16P Scr. Term. 17-32	015671	1	
	Harness Assembly, Super Remote Lower	050681	1	
25	Decal, Connector ID (J1B)	038415	1	
26	Decal, Connector ID (J2B)	038416	1	
27	Bolt, 3/8-16 x 3/4" Hex Head	F05007-27	1	
28	Washer, 3/8" SAE Flat	F05011-3	1	
29	Nut, 3/8-16 Self-Locking Hex	F05010-19	1	
	Harness Assembly, D42 Remote Upper	050739	1	
	Harness Assembly, D62 Remote Upper	051274	1	
30	Gasket, Pressure Lube Panel	033488	1	
31	Plate, Pressure Lube Panel	033489	1	
32	Bolt, #10-24 x 1/2" Pan Head	F05015-17	4	
33	Bolt, #10-24 x 1 1/4" Hex Head	F05004-19	1	
	SLEEVE, 2.5" X 29' VCN W/VELCRO CLOSURE HARNESS	050993 ³	1	
34	BRACKET WELDMENT, REMOTE POWER BOX MOUNTING	015184	1	
35	WASHER, 5/16" SPLIT LOCK	F05011-13	4	
36	NUT, 5/16-18 HEX	F05010-17	4	
37	WASHER, 3/8" EXTERIOR STAR LOCK	F05011-36	6	
38	WASHER, 3/8" SPLIT LOCK	F05011-4	6	
39	BOLT, 3/8-16 X 1" SOCKET HEAD	F05007-52	6	

¹ 70A Breaker 015527 replaces 50A Breaker 021256 for Up/Down Circuit to reduce nuisance tripping (12/06).

² 200 Amp Solenoid Kit 052387 replaces 100 Amp Kit 016372 with 100A Solenoid P10449 supplied prior to Rev. A2.01 to improve current capacity. Kit includes solenoid and replacement instructions. Diode Assembly 015426 added to prevent damage to hydraulic microswitch (8/04).

³ Added 3/03.

5.12 Remote Junction Box (AC)

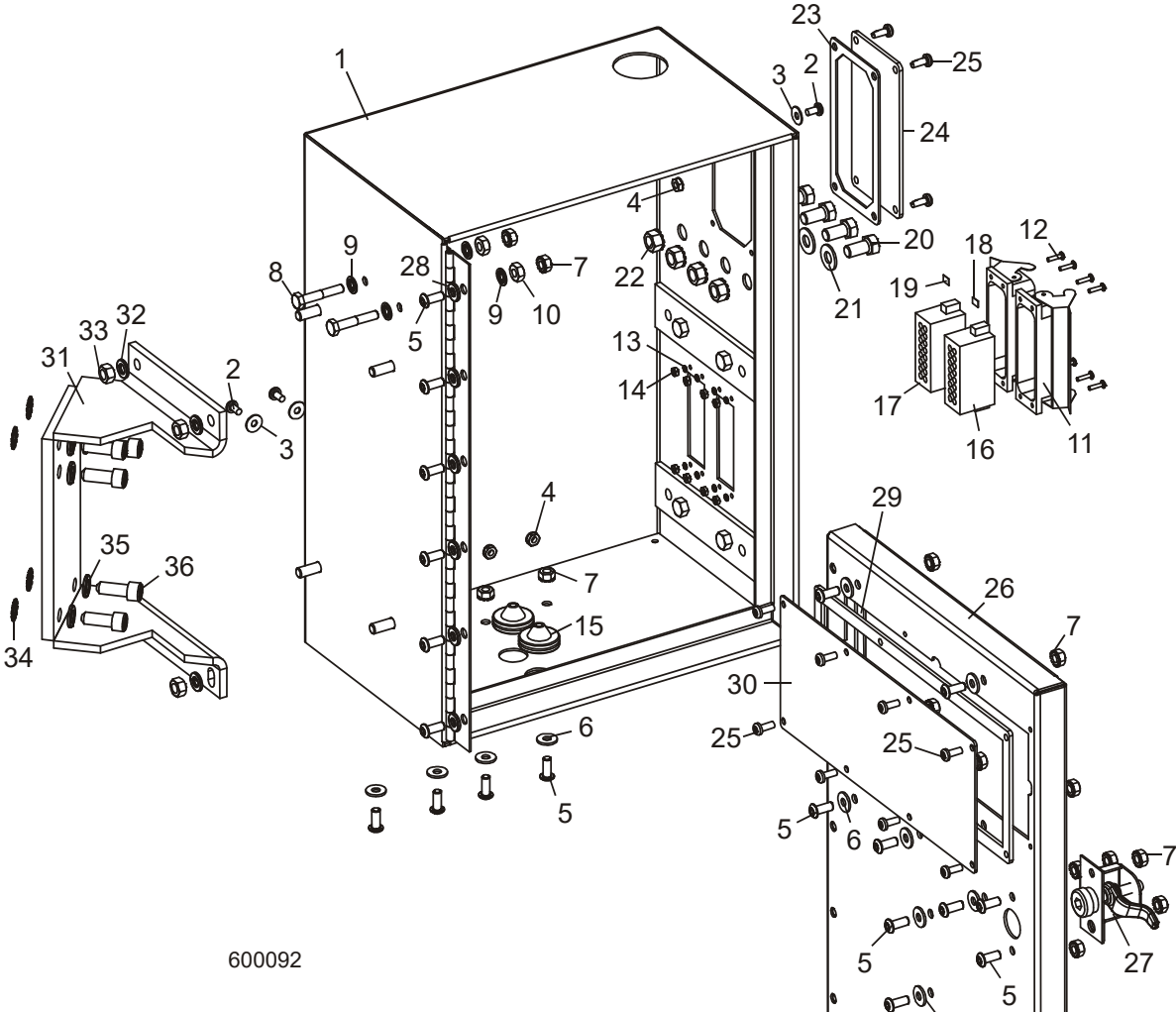

600092

REF	DESCRIPTION (◆ Indicates Parts Available In Assemblies Only)	PART #	QTY.
	BOX ASSEMBLY, E25 REMOTE JUNCTION	050801	1
1	Box Weldment, Remote Power	050278	1
2	Screw, #10-24 x 3/8" Cross-Slotted Pan Head	F05004-3	3
3	Washer, #10 SAE Flat	F05011-18	3
4	Nut, #10-24 Self-Locking Hex	F05010-14	3
5	Bolt, 1/4-20 x 5/8" Button Socket Head	F05005-128	22
6	Washer, 1/4" SAE Flat	F05011-11	14
7	Nut, 1/4-20 Self-Locking Hex	F05010-9	18
8	Bolt, 1/4-20 x 1 1/2" Hex Head Full Thread	F05005-31	2
9	Washer, 1/4" Exterior Star Lock	F05011-69	4
10	Nut, 1/4-20 Heavy-Duty Hex Jam	F05010-129	2
11	Connector, 16-Pin Panel Mount Single Lever	E23103	2

5

Control & Battery Boxes*Remote Junction Box (AC)*

12	Screw, #4-40 x 1/2" Slotted Round Head	F05004-14	8	
13	Washer, #4 Split Lock	F05011-21	8	
14	Nut, #4-40 Hex	F05010-43	8	
15	Grommet, Rubber Nipple Sealed	P11945	2	
16	Insert, Female 10A 16P Scr. Term. 1-16	E23106	1	
17	Insert, Female 10A 16P Scr. Term. 17-32	015671	1	
18	Decal, Connector ID (J1B)	038415	1	
19	Decal, Connector ID (J2B)	038416	1	
20	Bolt, 3/8-16 x 3/4" Hex Head	F05007-27	4	
21	Washer, 3/8" SAE Flat	F05011-3	4	
22	Nut, 3/8-16 Self-Locking Hex	F05010-19	4	
	Harness Assembly, E25 Remote Upper	050740	1	
	Cable Assembly, AC LT70-R Power Feed Service	052858	1	
23	Gasket, Pressure Lube Panel	033488	1	
24	Plate, Pressure Lube Panel	033489	1	
25	Bolt, #10-24 x 1/2" Pan Head	F05015-17	12	
26	Door Weldment, Remote Junction Box	035430	1	
27	Latch, Box Door	P20048	1	
28	Washer, 1/4" Split Lock	F05011-14	6	
29	Gasket, Remote Accuset Panel	024869	1	
30	Panel, Remote Accuset	024879	1	
	SLEEVE, 2.5" X 29' VCN W/VELCRO CLOSURE HARNESS	050993 ¹	1	
31	BRACKET WELDMENT, REMOTE POWER BOX MOUNTING	015184	1	
32	WASHER, 5/16" SPLIT LOCK	F05011-13	4	
33	NUT, 5/16-18 HEX	F05010-17	4	
34	WASHER, 3/8" EXTERIOR STAR LOCK	F05011-36	6	
35	WASHER, 3/8" SPLIT LOCK	F05011-4	6	
36	BOLT, 3/8-16 X 1" SOCKET HEAD	F05007-52	6	

¹ Added 3/03.

5.13 Remote Power Box Door Assembly (DC Only)

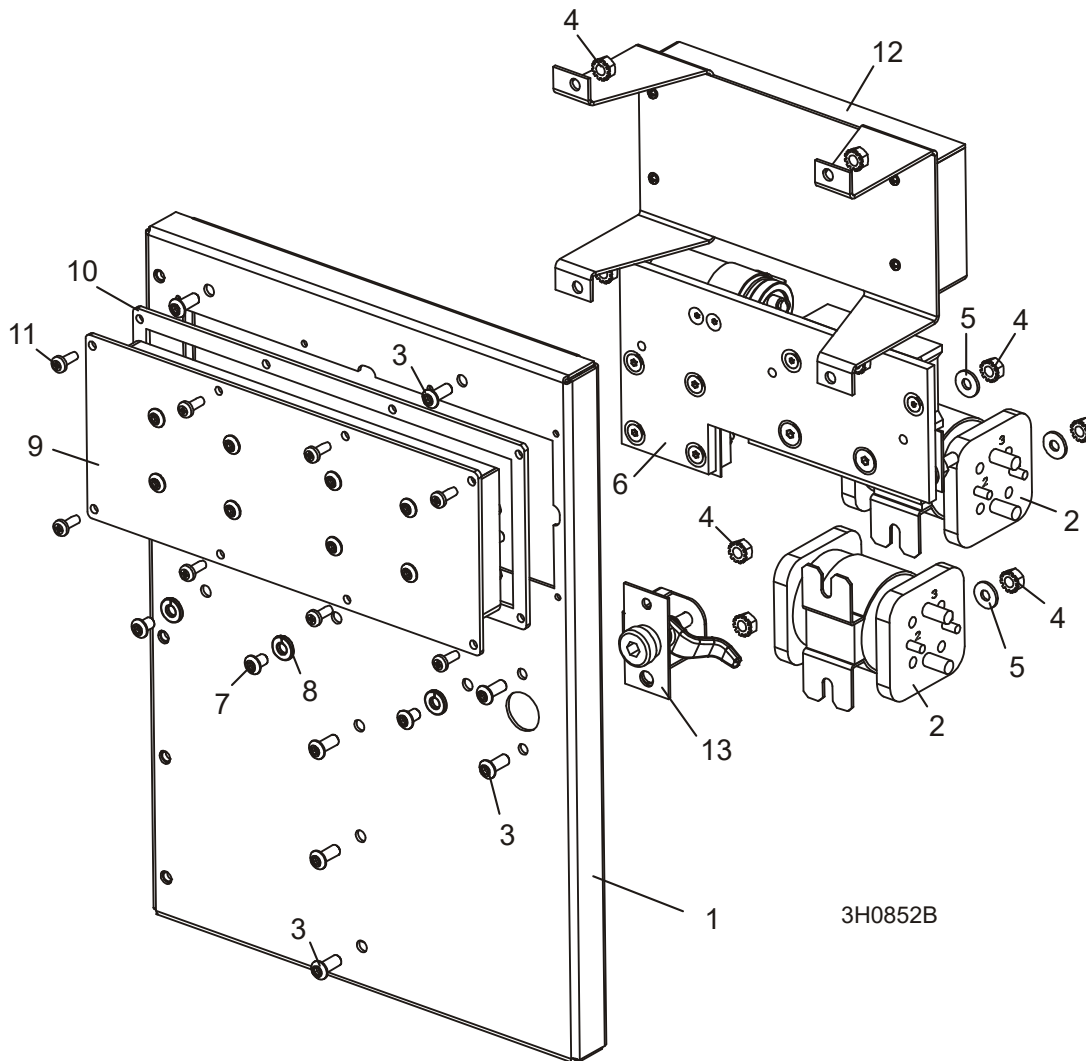

REF	DESCRIPTION (◆ Indicates Parts Available In Assemblies Only)	PART #	QTY.
	DOOR ASSEMBLY, REMOTE POWER BOX W/ACCUSET	035571	1
1	Door Weldment, Remote Power Box	035430	1
2	Solenoid Kit, 200A 12V DPST	016370 ¹	2
	Solenoid, 200A 12 DPST	015417	1 ◆
	Diode Assembly, Solenoid Coil Chassis GND	015426	1
3	Bolt, 1/4-20 x 5/8" Button Socket Head	F05005-128	9
4	Nut, 1/4-20 Self-Locking Hex	F05010-9	9
5	Washer, 1/4" SAE Flat	F05011-11	3
6	Circuit Board Assembly, Remote Power Feed	024457	1
	Control Module, Power Feed SMT	024396-1	1

5

Control & Battery Boxes

Remote Power Box Door Assembly (DC Only)

	Mosfet Module, Power Feed SMT	024387	1	
	Suppressor Assembly, Power Feed	052294 ²	1	
	Capacitor Assembly, Power Feed Filter	051571	1	
	Diode Assembly, Power Feed Replacement	052363	1	
7	Bolt, 1/4-20 x 3/8" Socket Button Head	F05005-62	3	
8	Washer, 1/4" Split Lock	F05011-14	3	
9	Panel Assembly, Remote Accuset Mosfet	024768	1	◆
10	Gasket, Remote Accuset Mosfet Panel	024869	1	
11	Screw, #10-24 x 1/2" Phillips Head	F05015-17	8	
	Harness, Remote Accuset Power	025058	1	
12	Circuit Board Assembly, Remote Accuset	052884	1	◆
	Filter Assembly, Accuset Power	051260 ³	1	
13	Latch, Power Box Door	P20048	1	

¹ Diode Wire Assembly 015426 added to Solenoid Kit 016370 (8/04).

² Suppressor Assembly 052294 added 6/05 to protect feed circuit.

³ Filter Assembly added Rev. A2.01 to improve Accuset functionality and durability. Use kit 051262 to retrofit previous revisions.

SECTION 6 UP/DOWN SYSTEM

6.1 Up/Down Rollers & Covers

LT60HD/70HD Remote Rev. A2.00 - A3.00

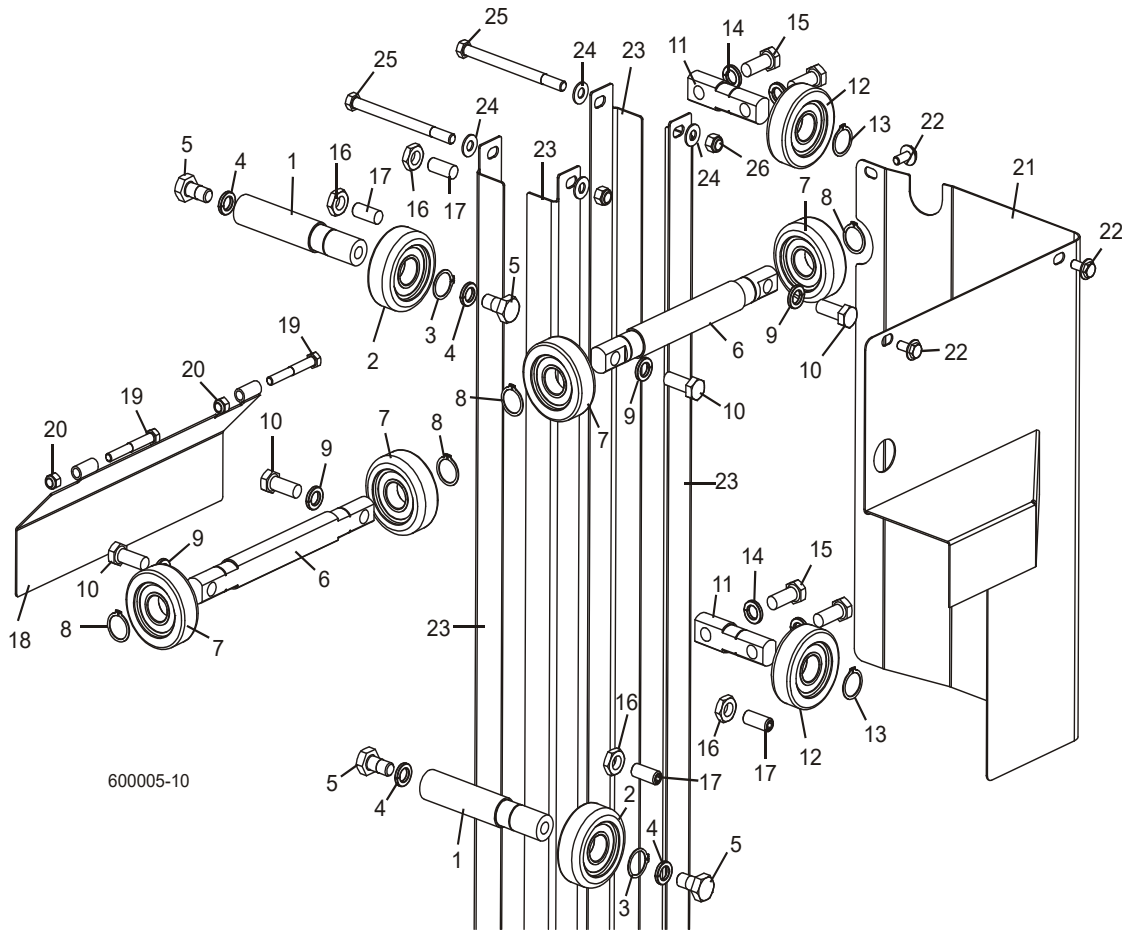

600005-10

REF	DESCRIPTION (◆ Indicates Parts Available In Assemblies Only)	PART #	QTY.
	ROLLER ASSEMBLY, INSIDE UP/DOWN	034339	2
1	Shaft, Inside Up/Down Roller	033855	1
2	Bearing, MG305DDA	023857	1
3	Ring, 1" Outside Retaining	F04254-15	1
4	Washer, 1/2" Split Lock	F05011-9	2
5	Bolt, 1/2-13 x 1" Hex Head Grade 2	F05008-50	2
	ROLLER ASSEMBLY, LONG UP/DOWN	034337	2
6	Shaft, Long Up/Down Roller	033853	1
7	Bearing, MG305DDA	023857	2
8	Ring, 1" Outside Retaining	F04254-15	2
9	Washer, 1/2" Split Lock	F05011-9	2

6

Up/Down System*Up/Down Rollers & Covers*

10	Bolt, 1/2-13 x 1 1/4" Hex Head Grade 5	F05008-37	2	
	ROLLER ASSEMBLY, SHORT UP/DOWN	034338	2	
11	Shaft, Short Up/Down Roller	033854	1	
12	Bearing, MG305DDA	023857	1	
13	Ring, 1" Outside Retaining	F04254-15	1	
14	Washer, 1/2" Split Lock	F05011-9	2	
15	Bolt, 1/2-13 x 1 1/2" Hex Head Grade 5	F05008-33	2	
16	NUT, 1/2-13 HEX JAM	F05010-31	4	
17	SCREW, 1/2-13 X 1 1/4" BRASS TIP SET	F05008-18	4	
18	COVER WELDMENT, LOWER UP/DOWN ROLLER	034277	1	
19	BOLT, 5/16-18 X 2 1/2" HEX HEAD GRADE 5	F05006-80	2	
20	NUT, 5/16-18 NYLON LOCK	F05010-58	2	
21	COVER WELDMENT, UP/DOWN DRIVE (D42)	036182	1	
	COVER WELDMENT, UP/DOWN DRIVE (E25)	036184	1	
22	BOLT, 5/16-18 X 3/4" HEX WASHER HEAD	F05006-101	4	
23	ANGLE, MAST TUBE STAINLESS	033827	4	
24	WASHER, 3/8" SAE FLAT	F05011-3	8	
25	BOLT, 3/8-16 X 5" HEX HEAD	F05007-5	4	
26	NUT, 3/8-16 NYLON LOCK	F05010-10	4	

6.2 Up/Down Rollers & Covers

LT60HD/70HD Remote *Rev. A1.00 - A1.09*

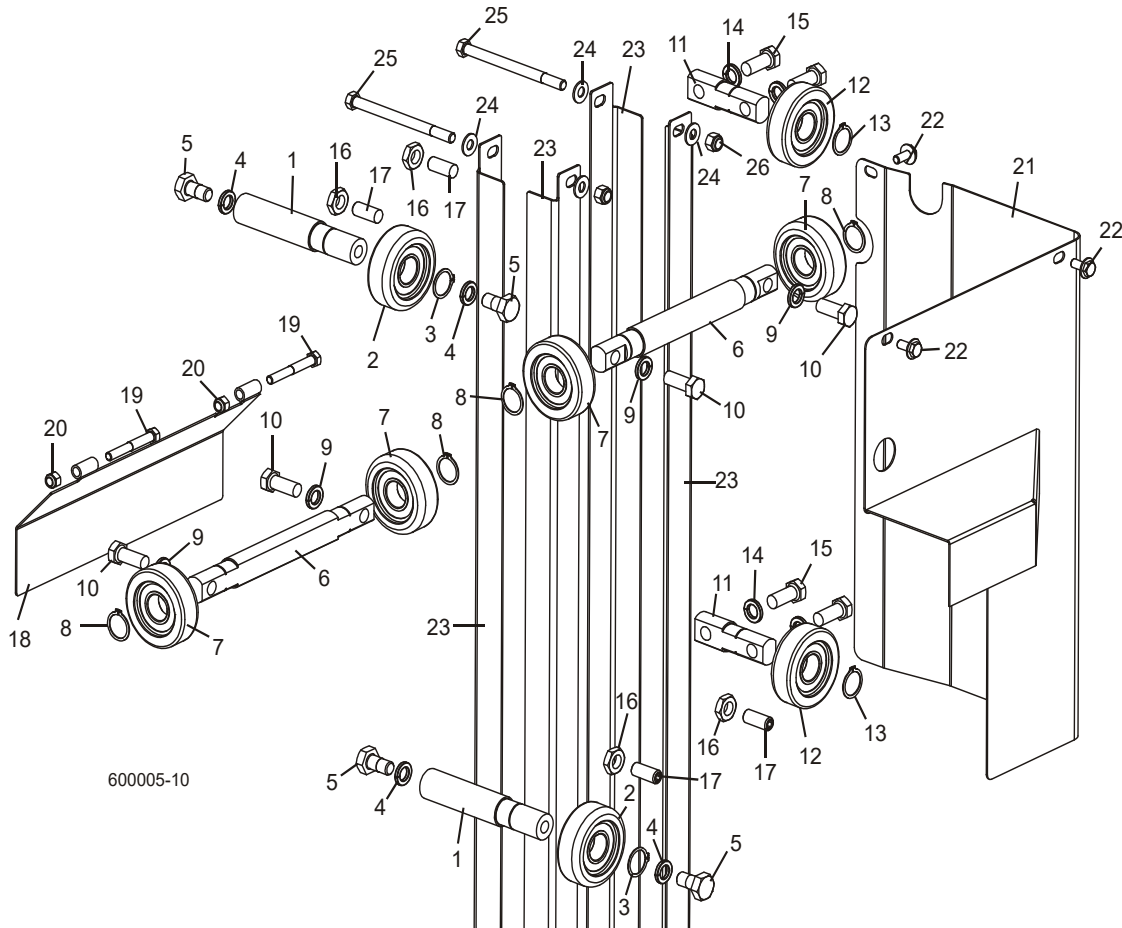

REF	DESCRIPTION (◆ Indicates Parts Available In Assemblies Only)	PART #	QTY.
	ROLLER ASSEMBLY, INSIDE UP/DOWN	034339	2
1	Shaft, Inside Up/Down Roller	033855	1
2	Bearing, MG305DDA	023857	1
3	Ring, 1" Outside Retaining	F04254-15	1
4	Washer, 1/2" Split Lock	F05011-9	2
5	Bolt, 1/2-13 x 1" Hex Head Grade 2	F05008-50	2
	ROLLER ASSEMBLY, LONG UP/DOWN	034337	2
6	Shaft, Long Up/Down Roller	033853	1
7	Bearing, MG305DDA	023857	2
8	Ring, 1" Outside Retaining	F04254-15	2
9	Washer, 1/2" Split Lock	F05011-9	2
10	Bolt, 1/2-13 x 1 1/4" Hex Head Grade 5	F05008-37	2
	ROLLER ASSEMBLY, SHORT UP/DOWN	034338	2
11	Shaft, Short Up/Down Roller	033854	1

6

Up/Down System*Up/Down Rollers & Covers*

12	Bearing, MG305DDA	023857	1	
13	Ring, 1" Outside Retaining	F04254-15	1	
14	Washer, 1/2" Split Lock	F05011-9	2	
15	Bolt, 1/2-13 x 1 1/2" Hex Head Grade 5	F05008-33 ¹	2	
16	NUT, 1/2-13 HEX JAM	F05010-31	4	
17	SCREW, 1/2-13 X 1 1/4" BRASS TIP SET	F05008-18	4	
18	COVER WELDMENT, LOWER UP/DOWN ROLLER	034277	1	
19	BOLT, 5/16-18 X 2 1/2" HEX HEAD GRADE 5	F05006-80	2	
20	NUT, 5/16-18 NYLON LOCK	F05010-58	2	
21	COVER WELDMENT, UP/DOWN DRIVE (D42)	034381 ²	1	
	COVER WELDMENT, UP/DOWN DRIVE (E25)	017755 ²	1	
22	BOLT, 5/16-18 X 3/4" HEX WASHER HEAD	F05006-101	4	
23	ANGLE, MAST TUBE STAINLESS	033827	4	
24	WASHER, 3/8" SAE FLAT	F05011-3	8	
25	BOLT, 3/8-16 X 5" HEX HEAD	F05007-5	4	
26	NUT, 3/8-16 NYLON LOCK	F05010-10	4	

¹ Replaces 1 1/4" Bolt F05008-37 originally supplied prior to Rev. A2.00. Longer bolt provides easier adjustment.

² Covers replaced for use with larger up/down gear box after Rev. A2.00 ([See Section 6.1](#)).

6.3 Blade Height & Quarter Scales

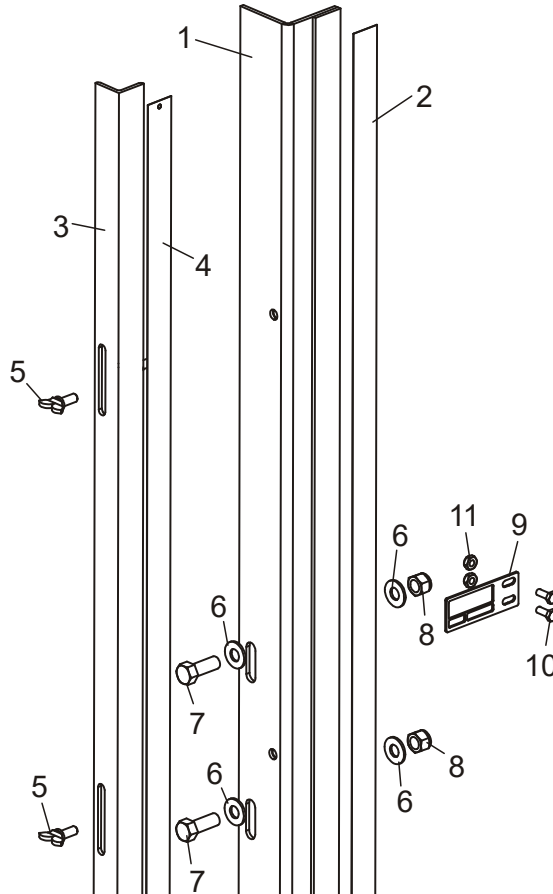

600123-2

REF	DESCRIPTION (◆ Indicates Parts Available In Assemblies Only)	PART #	QTY.
	SCALE ASSEMBLY, LT70	034372	1
1	Angle Weldment, Scale Mount	034370	1
2	Decal, Movable Inch Scale	S11773	1
	Scale Assembly, LT60/70 Quarter	034371	1
3	Angle, Quarter Scale Mount	034369	1
4	Decal, Movable Grade Quarter Scale	P12819 ¹	1
5	Screw, 1/4-20 x 5/8" Wing	F05005-64	2
6	Washer, 3/8" SAE Flat	F05011-3	4
7	Bolt, 3/8-16 x 1" Hex Head	F05007-7	2
8	Nut, 3/8-16 Hex Nylon Lock	F05010-10	2
9	INDICATOR, BLADE HEIGHT	017778	1
10	SCREW, #10-24 X 1/2" HEX HEAD STAINLESS STEEL	F05004-27	2
11	NUT, #10-24 SELF-LOCKING HEX	F05010-160	2

¹ Grade Quarter Scale Decal P12819 provided with sawmill beginning with Rev. A1.02. Standard Quarter Scale Decal S11774 available separately. Order Angle Mount 034369 and Standard Quarter Scale Decal S11774.

6.4 Up/Down Chain & Sprockets

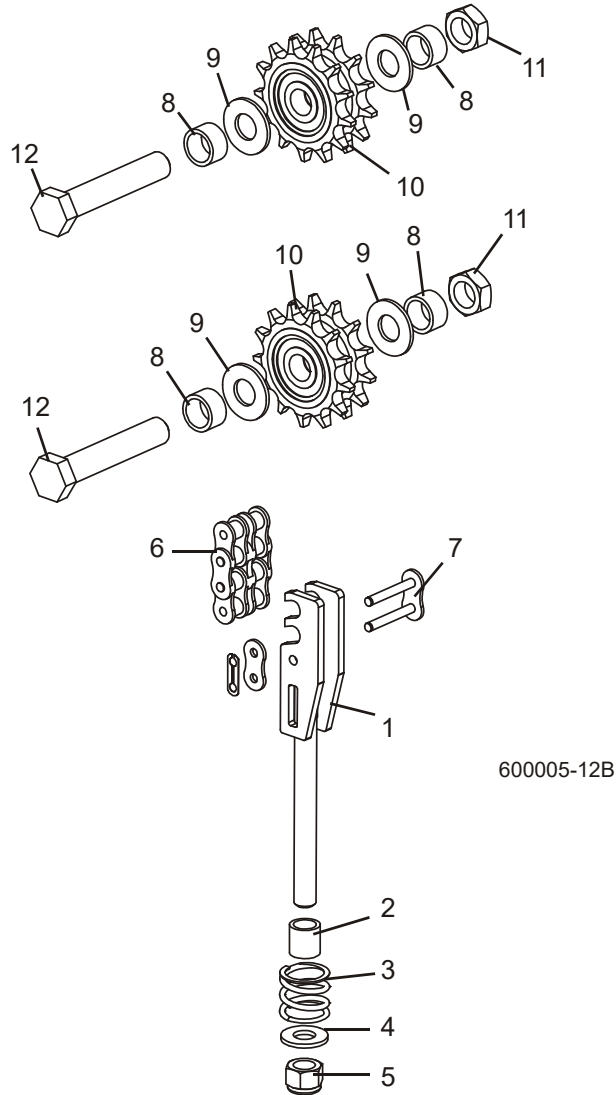

REF	DESCRIPTION (◆ Indicates Parts Available In Assemblies Only)	PART #	QTY.
	TENSIONER ASSEMBLY, LT70 UP/DOWN CHAIN	034238	1
1	Tensioner Weldment, Up/Down Chain	034236	1
2	Spacer, Up/Down Chain Tensioner	016515	1
3	Spring, 1" OD x 1" Long x .125 Wire Compression	016516	1
4	Washer, 1/2" SAE Flat	F05011-2	1
5	Nut, 1/2-13 Nylon Lock	F05010-8	1
6	CHAIN, LT70 UP/DOWN #50-2 X 73 1/8"	036197 ¹	1
7	LINK, #50-2 MASTER	015258	2

8	SPACER, #50-2 IDLER	016018	4	
9	WASHER, 5/8" SAE FLAT	F05011-5	4	
10	SPROCKET ASSEMBLY, #50-2 UP/DOWN IDLER	016019	2	
11	NUT, 5/8-11 HEX NYLON LOCK JAM	F05010-96	2	
12	BOLT, 5/8-11 X 3 1/2" HEX HEAD GRADE 5	F05009-93	2	

¹ Purchased chain 036197 replaces manufactured chain 015259 supplied prior to Rev. A2.00

6.5 Up/Down Drive Assembly

LT70HD Remote

Rev. A2.00 - A3.00

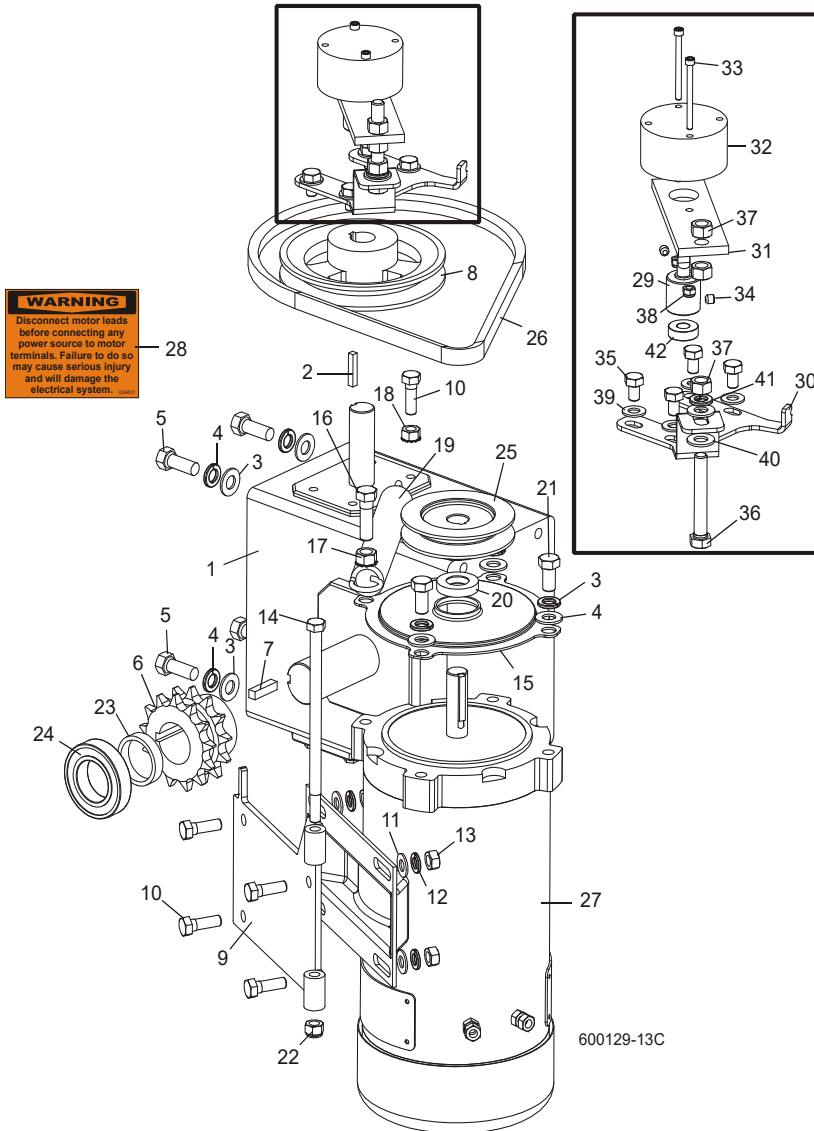

REF	DESCRIPTION (◆ Indicates Parts Available In Assemblies Only)	PART #	QTY.
1	GEAR BOX, B226-60-2-1L	034908	1
2	KEY, 3/16" SQUARE X 1" LONG	S31027	1
3	WASHER, 3/8" SAE FLAT	F05011-3	7
4	WASHER, 3/8" SPLIT LOCK	F05011-4	7
5	BOLT, 3/8-16 X 1" HEX HEAD	F05007-7	4
6	SPROCKET, DOUBLE 50-13 X 1 1/4"	036008	1
7	KEY, 1/4" SQUARE X 1" LONG	S21486	1
8	PULLEY, AK20 X 5/8" BORE	036179	1

9	BRACKET WELDMENT, UP/DOWN MOTOR MOUNT	015198	1	
10	BOLT, 5/16-18 X 1" HEX HEAD	F05006-1	5	
11	WASHER, 5/16" SAE FLAT	F05011-17	4	
12	WASHER, 5/16" SPLIT LOCK	F05011-13	4	
13	NUT, 5/16-18 HEX	F05010-17	4	
14	BOLT, 5/16-18 X 6" HEX HEAD GRADE 5	F05006-73	1	
15	COVER, UP/DOWN MOTOR	034475	1	
16	BOLT, 3/8-16 X 1 1/4" HEX HEAD GRADE 5	F05007-123	1	
17	NUT, 3/8-16 HEX SELF-LOCKING	F05010-19	1	
18	NUT, 5/16-18 HEX SELF-LOCKING	F05010-20	1	
19	SPRING, 1" OD X 7" LONG X .148 WIRE EXTENSION	019303	1	
20	SEAL, CR6315	034501	1	
21	BOLT, 3/8-16 X 3/4" HEX HEAD	F05007-27	3	
22	NUT, 5/16-18 NYLON LOCK	F05010-58	1	
23	SPACER, UP/DOWN SPROCKET	036016	1	
24	BEARING, R20-2RS	036007	1	
25	PULLEY, AK51 X 3/4" BORE	015256	1	
26	BELT, 4L300	021183	1	
27	MOTOR, 3/4HP 12VDC (DC ONLY)	015174	1	
	Brush Kit, Power Feed Motor (Includes 2 Brushes and 2 Springs)	024167	1	
	Fan, 3/4 HP Leeson Motor Replacement	016087	1	
	Guard, Motor Fan	047998	1	
	MOTOR, 1HP 230/460VAC 3P 1725RPM (AC ONLY)	050290	1	
28	DECAL, DISCONNECT MOTOR LEADS WARNING	024431	1	
	OIL, 8 OZ. MOBIL SHC634 BOTTLED SYNTHETIC GEAR	L04869-4 ¹	1	
	BRAKE ASSEMBLY, LT70 UP/DOWN	065188 ²	1	
29	Shaft, Up/Down Brake	062511	1	
30	Plate, LT70 Up/Dn Brake Mount	062512	1	
31	Plate, Brake Mount	062513	1	
32	Brake, Up/Down	069519	1	
33	Bolt, #8-32 x 2" Socket Head Stainless Steel	F05004-273	2	
34	Screw, 1/4-20 x 1/4" Cup Point Socket Set	F05005-131	2	
35	Bolt, 5/16-18 x 1/2" Hex Head Grade 5	F05006-15	2	
36	Bolt, 3/8-16 x 2 1/2" Hex Head Full Thread	F05007-157	1	
37	Nut, 3/8-16 Hex	F05010-1	3	
38	Nut, #8-32 Hex Nylon Lock	F05010-169	2	
39	Washer, 5/16" SAE Flat	F05011-17	4	
40	Washer, 3/8" SAE Flat	F05011-3	2	
41	Washer, 3/8" Split Lock	F05011-4	1	
42	Bearing, R6-2NSL SRI-2 ABEC-1	P10688	1	

¹ 40 oz. required for complete oil replacement.

² Brake added 2/11 to prevent saw head from drifting during sawing. Use retrofit kit 062566 to retrofit previous revisions.

6.6 Up/Down Drive Assembly

LT70HD Remote

Rev. A1.09

WARNING
Disconnect motor leads before connecting any power source to motor terminals. Failure to do so may cause serious injury and will damage the electrical system. 02451

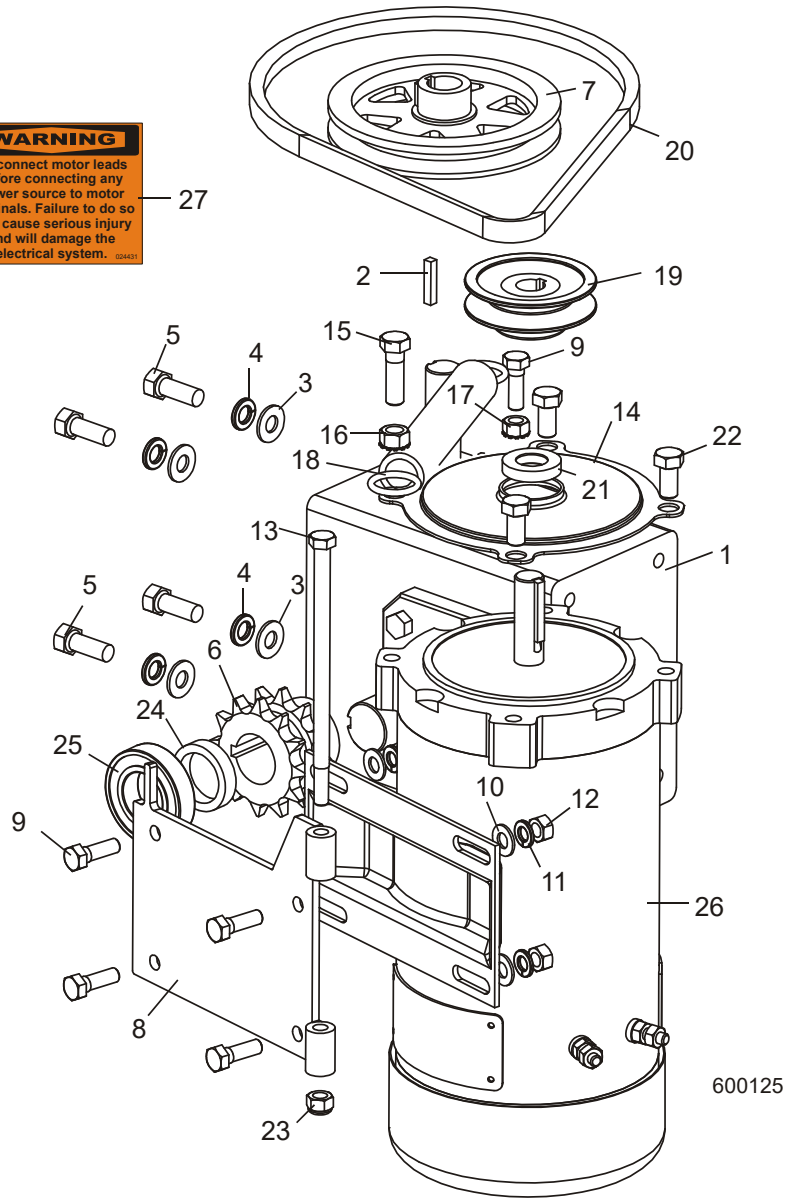

REF	DESCRIPTION (◆ Indicates Parts Available In Assemblies Only)	PART #	QTY.
1	GEAR BOX, GROVE UP/DOWN	014074 ¹	1
2	KEY, 3/16" SQUARE X 1" LONG	S31027	1
3	WASHER, 3/8" SAE FLAT	F05011-3	4
4	WASHER, 3/8" SPLIT LOCK	F05011-4	4
5	BOLT, 3/8-16 X 1" HEX HEAD	F05007-7	4

6	SPROCKET, DOUBLE 50-12 X 1 1/8"	033858	1	
	KEY, 1/4" SQUARE X 1 11/16" LONG	S04124	1	
7	PULLEY, AK51 X 3/4" BORE	015256	1	
8	BRACKET WELDMENT, UP/DOWN MOTOR MOUNT	015198	1	
9	BOLT, 5/16-18 X 1" HEX HEAD	F05006-1	5	
10	WASHER, 5/16" SAE FLAT	F05011-17	4	
11	WASHER, 5/16" SPLIT LOCK	F05011-13	4	
12	NUT, 5/16-18 HEX	F05010-17	4	
13	BOLT, 5/16-18 X 6" HEX HEAD GRADE 5	F05006-73	1	
14	COVER, UP/DOWN MOTOR	034475	1	
15	BOLT, 3/8-16 X 1 1/4" HEX HEAD GRADE 5	F05007-123	1	
16	NUT, 3/8-16 HEX SELF-LOCKING	F05010-19	1	
17	NUT, 5/16-18 HEX SELF-LOCKING	F05010-20	1	
18	SPRING, 1" OD X 7" LONG X .148 WIRE EXTENSION	019303	1	
	BELT/PULLEY KIT, LT60HD/70HD UP/DOWN	036211	1	
19	Pulley, AK20 x 5/8" Bore	036179	1	
20	Belt, 4L290 Notched	036206	1	
21	SEAL, CR6315	034501	1	
22	BOLT, 3/8-16 X 3/4" HEX HEAD	F05007-27	3	
23	NUT, 5/16-18 NYLON LOCK	F05010-58	1	
24	SPACER, UP/DOWN SPROCKET	033868	1	
25	BEARING, R18	034380	1	
26	MOTOR, 3/4HP 12VDC (D42 ONLY)	015174	1	
	Brush Kit, Power Feed Motor (Includes 2 Brushes and 2 Springs)	024167	1	
	Fan, 3/4 HP Leeson Motor Replacement	016087	1	
	Guard, Motor Fan	047998	1	
	MOTOR, 1HP 230/460VAC 3P 1725RPM (E25 ONLY)	050290	1	
27	DECAL, DISCONNECT MOTOR LEADS WARNING	024431	1	
	OIL, 8 OZ. MOBIL SHC634 BOTTLED SYNTHETIC GEAR	L04869-4 ²	1	

¹ Up/Down brake retrofit 062566 available to prevent drifting during sawing ([See Section 6.5](#)).

² 24 oz. required for complete oil replacement.

6.7 Up/Down Drive Assembly

LT70HD Remote

Rev. A1.00 - A1.08

WARNING
Disconnect motor leads before connecting any power source to motor terminals. Failure to do so may cause serious injury and will damage the electrical system. 02451

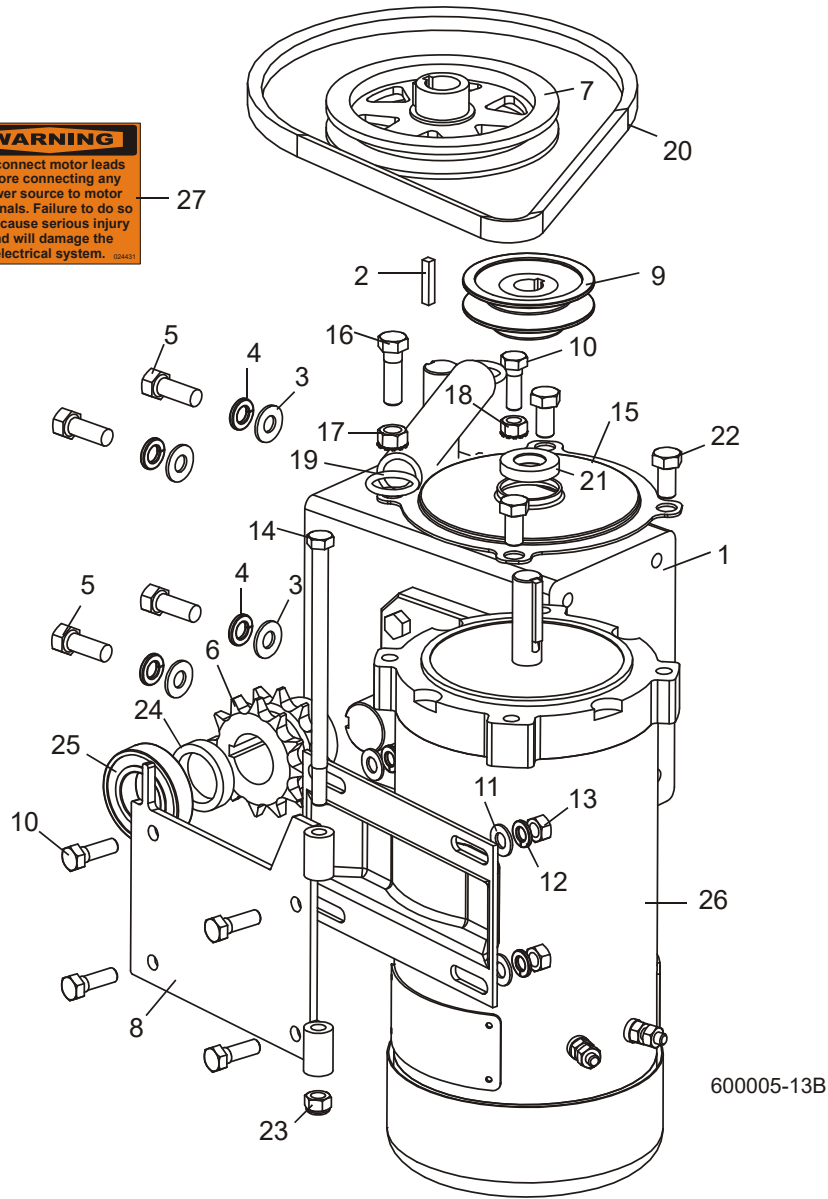

REF	DESCRIPTION (◆ Indicates Parts Available In Assemblies Only)	PART #	QTY.
1	GEAR BOX, GROVE UP/DOWN	014074 ¹	1
2	KEY, 3/16" SQUARE X 1" LONG	S31027	1
3	WASHER, 3/8" SAE FLAT	F05011-3	4
4	WASHER, 3/8" SPLIT LOCK	F05011-4	4
5	BOLT, 3/8-16 X 1" HEX HEAD	F05007-7	4
6	SPROCKET, DOUBLE 50-12 X 1 1/8"	033858	1

7	PULLEY, AK51 X 3/4" BORE	015256	1	
8	BRACKET WELDMENT, UP/DOWN MOTOR MOUNT	015198	1	
9	PULLEY, AK28 X 5/8" BORE	033852 ²	1	
10	BOLT, 5/16-18 X 1" HEX HEAD	F05006-1	5	
11	WASHER, 5/16" SAE FLAT	F05011-17	4	
12	WASHER, 5/16" SPLIT LOCK	F05011-13	4	
13	NUT, 5/16-18 HEX	F05010-17	4	
14	BOLT, 5/16-18 X 6" HEX HEAD GRADE 5	F05006-73	1	
15	COVER, UP/DOWN MOTOR	034475	1	
16	BOLT, 3/8-16 X 1 1/4" HEX HEAD GRADE 5	F05007-123	1	
17	NUT, 3/8-16 HEX SELF-LOCKING	F05010-19	1	
18	NUT, 5/16-18 HEX SELF-LOCKING	F05010-20	1	
19	SPRING, 1" OD X 7" LONG EXTENSION	P410	1	
20	BELT, 4L300	021183 ²	1	
21	SEAL, CR6315	034501	1	
22	BOLT, 3/8-16 X 3/4" HEX HEAD	F05007-27	3	
23	NUT, 5/16-18 NYLON LOCK	F05010-58	1	
24	SPACER, UP/DOWN SPROCKET	033868	1	
25	BEARING, R18	034380	1	
26	MOTOR, 3/4HP 12VDC (D42 ONLY)	015174	1	
	Brush Kit, Power Feed Motor (Includes 2 Brushes and 2 Springs)	024167	1	
	Fan, 3/4 HP Leeson Motor Replacement	016087	1	
	Guard, Motor Fan	047998	1	
	MOTOR, 1HP 230/460VAC 3P 1725RPM (E25 ONLY)	050290	1	
27	DECAL, DISCONNECT MOTOR LEADS WARNING	024431	1	
	OIL, 8 OZ. MOBIL SHC634 BOTTLED SYNTHETIC GEAR	L04869-4 ³	1	

¹ Up/Down brake retrofit 062566 available to prevent drifting during sawing ([See Section 6.5](#)).

² Motor Pulley and Belt replaced to accommodate Rev. B.00 Accuset. Use kit 036211 to retrofit revisions prior to Rev. A1.09 ([See Section 6.5](#)).

³ 24 oz. required for complete oil replacement.

SECTION 7 FEED SYSTEM & TRACK ROLLERS

7.1 Upper Track Rollers And Wipers

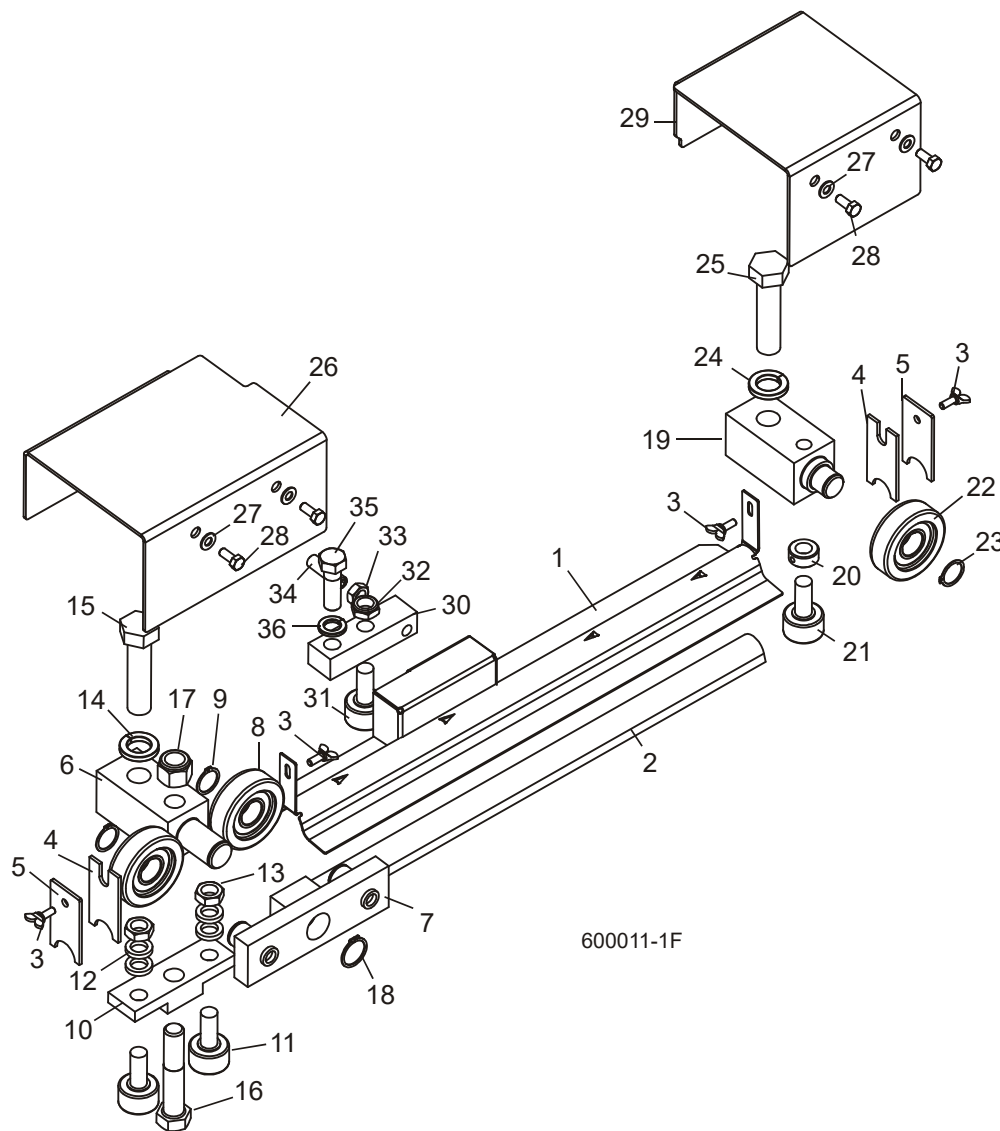

REF	DESCRIPTION (◆ Indicates Parts Available In Assemblies Only)	PART #	QTY.	
	WIPER ASSEMBLY, MIDDLE TRACK	017928 ¹	1	
1	Wiper Housing, Middle Track	017920	1	◆
2	Wiper, 3/16" x 2" x 23" Felt	S09915	1	
3	BOLT, 1/4-20 X 5/8" WING	F05005-64	4	
4	WIPER, TOP RAIL	M04113	2	
5	PLATE, TRACK WIPER	034229	2	
	ROLLER ASSEMBLY, FRONT UPPER TRACK	042506	1	

Feed System & Track Rollers

Upper Track Rollers And Wipers

7

6	Block, Upper Roller Mount	042505	1	
7	Block Assembly, Upper Roller	042507	1	
8	Bearing, MG305DDA	023857	2	
9	Ring, 1" Outer Retaining	F04254-15	2	
10	Block, Track Bearing Mount	042500	1	
11	Bearing, 1 1/2" Track	012797	2	
12	Spacer, 41/64" x 1" x 3/16"	S12480	4	
13	Nut, 5/8-18 Hex Jam	F05010-11	2	
14	Washer, 7/8" Split Lock	F05011-46	1	
15	Bolt, 7/8-14 x 3 1/2" Hex Head Grade 5	F05014-1	1	
16	Bolt, 3/4-10 x 4" Hex Head Grade 5	F05013-3 ²	1	
17	Nut, 3/4-10 Hex Nylon Lock	F05010-103	1	
18	Ring, 1 1/8" Outer Retaining	F04254-36	1	
	ROLLER ASSEMBLY, REAR UPPER TRACK	034231	1	
19	Block, Upper Roller Mount	034230	1	
20	Collar, 5/8" ID Lock	P05035	1	
21	Bearing, 1 1/2" Track	012797	1	
22	Bearing, MG305DDA	023857	1	
23	Ring, 1" Outer Retaining	F04254-15	1	
24	Washer, 7/8" Split Lock	F05011-46	1	
25	Bolt, 7/8-14 x 3 1/2" Hex Head Grade 5	F05014-1	1	
26	COVER, FRONT UPPER TRACK ROLLER	033942	1	
27	WASHER, 5/16" SPLIT LOCK	F05011-17	4	
28	BOLT, 5/16-18 X 3/4" HEX HEAD	F05006-102	4	
29	COVER, REAR UPPER TRACK ROLLER	033939 ³	1	
30	BLOCK, MIDDLE UPPER TRACK ROLLER MOUNT	017884	1	
31	BEARING, 1 1/2" TRACK	012797	1	
32	NUT, 5/8-18 NYLON HEX JAM	F05010-101	1	
33	NUT, 1/2-20 HEX JAM	F05010-16	1	
34	SCREW, 1/2-20 X 1 3/4" FLAT POINT SET	F05008-112	1	
35	BOLT, 5/8-11 X 2" HEX HEAD	F05009-2	1	
36	WASHER, 5/8" SPLIT LOCK GRADE 8	F05011-118 ⁴	1	

¹ Middle Track Wiper Assembly 017928 replaces A09918 originally supplied prior to Rev. A1.02.

² Bolt reoriented so head is at bottom of assembly to eliminate interference with 2002 bedX connection hardware (1/02).

³ Optional Feed Motor Guard available 12/06 ([See Section 7.2](#)).

⁴ Grade 8 washer replaces F05011-27 originally supplied to improve durability.

7.2 Power Feed Assembly

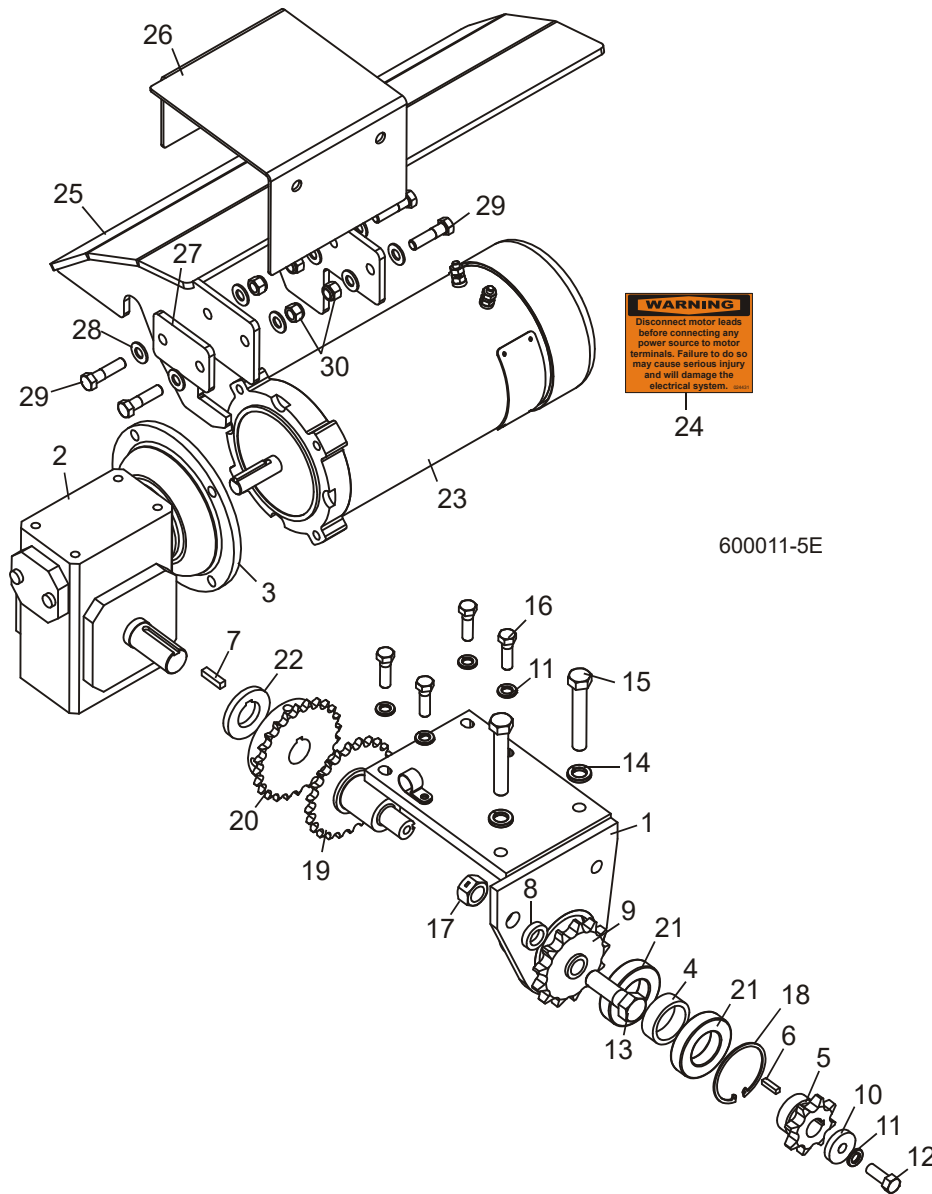

REF	DESCRIPTION (◆ Indicates Parts Available In Assemblies Only)	PART #	QTY.
	POWER FEED ASSEMBLY	034860	1
1	Bracket Weldment, Power Feed Mount	034850	1
2	Gearbox, Power Feed	034843	1
3	Plate, Gearbox Adaptor	057444	1
4	Spacer, 1.185 x 1.5 x .428	034856	1
5	Sprocket, 60B8 x 3/4" Modified	017723	1
6	Key, 3/16" Square x 3/4" Long	S03060	2

7	Key, 1/4" Square x 1" Long	S21486	1	
8	Spacer, .63 x 1.00 x .226	017719	1	
9	Sprocket, 60BB13H x 5/8" Idler	034224	1	
10	Washer, 3/8" ID x 1 1/4" OD	S02779	1	
11	Washer, 3/8" Split Lock	F05011-4	5	
12	Bolt, 3/8-16 x 1" Hex Head	F05007-7	1	
13	Bolt, 5/8-11 x 2" Hex Head Gr2	F05009-2	1	
14	Washer, 1/2" Split Lock	F05011-9	2	
15	Bolt, 1/2-20 x 3" Hex Head Full Thread	F05008-62	2	
16	Bolt, 3/8-16 x 1 1/4" Hex Head Full Thread Grade 5	F05007-123	4	
17	Nut, 5/8-11 Swaged Hex	F05010-4	1	
18	Ring, 62mm IR	F04254-12	1	
19	Shaft Weldment, LT60/70 Power Feed	034855	1	
20	Sprocket, 40B24 x1	034851	1	
21	Bearing, 6007-2RS 35x62x14	034852	2	
22	Spacer, 1.03" ID x 2" OD x 3/8" Keyed	034857	1	
	Chain, Double #40 x 11 1/2"	036196 ¹	1	
	Link, #40 x 2 Connecting	017724	1	
	Oil, 8 Oz. Mobil SHC634 Bottled Synthetic Gear	L04869-4 ²	1	
23	MOTOR, 3/4HP 12VDC POWER FEED (D42 ONLY)	024169	1	
	Brush Kit, Leeson 3/4HP Motor (Includes 2 Brushes and 2 Springs)	024167	1	
	Fan, 3/4 HP Leeson Motor Replacement	016087	1	
	Guard, Motor Fan	047998	1	
	Hub, Motor Fan Extension	047999	1	
	Key, 3/16" Square x 1" Long	S31027	1	
	MOTOR, 1.5HP 230/460VAC 3P 1725RPM POWER FEED (E25 ONLY)	050291	1	
24	DECAL, DISCONNECT MOTOR LEADS WARNING	024431	1	
	GUARD ASSEMBLY, LT70 FEED MOTOR (OPTIONAL)	038878-A ³	1	
25	Guard Weldment, LT70 Feed Motor	038877	1	
26	Guard, Top Track Roller	038876	1	
27	Plate, LT70 Power Feed Guard Spacer	038874	1	
28	Washer, 3/8" SAE Flat	F05011-3	8	
29	Bolt, 3/8-16 x 1 1/2" Hex Head Grade 5	F05007-78	4	
30	Nut, 3/8-16 Hex Nylon Lock	F05010-10	4	

¹ Purchased chain 036196 replaces manufactured chain R02125 supplied prior to Rev. A2.00

² 12 - 15 oz. required for complete oil replacement.

³ Optional feed motor guard available 12/06 to protect motor & gearbox from falling logs. Drilling of mounting holes required.

7 Power Feed System

Feed Chain/Stop

7.3 Feed Chain/Stop

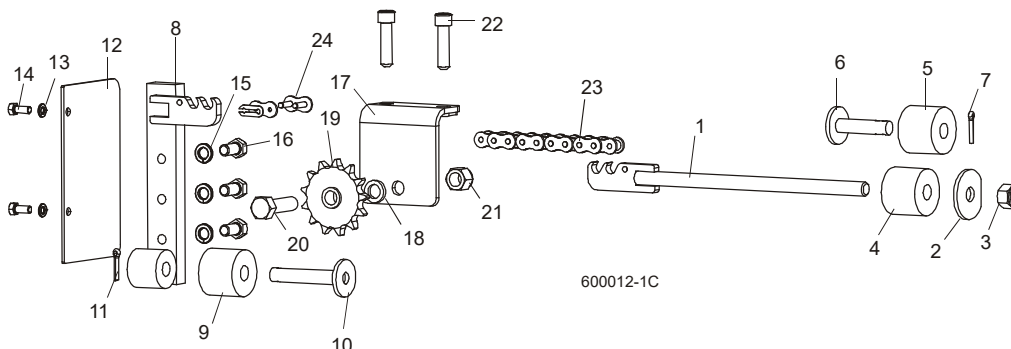

REF	DESCRIPTION (◆ Indicates Parts Available In Assemblies Only)	PART #	QTY.
	STOP ASSEMBLY, FRONT POWER FEED	034556	1
1	Tensioner Weldment, Power Feed Chain	034421	1
2	Washer, 21/32" x 2 1/4" x 3/16" D	017838	1
3	Nut, 5/8-11 Nylon Lock	F05010-34	1
4	Stop, Rubber Carriage	P12165	1
	Stop Kit, Rubber Carriage	K09630	1
5	Stop, Rubber Carriage	P12165	1
6	Pin, Rubber Carriage Stop	W09293	1
7	Pin, 3/16" X 1" Cotter	F05012-21	1
	STOP ASSEMBLY, REAR POWER FEED	034557	1
8	Stop Weldment, Rear Power Feed	034433	1
9	Stop, Rubber Carriage	P12165	1
10	Pin, Rear Carriage Stop	034423	1
11	Pin, 3/16" X 1" Cotter	F05012-21	1
12	Plate, Bed Tube End	034455	1
13	Washer, 5/16" Split Lock	F05011-13	2
14	Bolt, 5/16-18 x 3/4" Hex Head	F05006-5	2
15	Washer, 1/2" Split Lock	F05011-9	3
16	Bolt, 1/2-13 x 1" Hex Head Grade 8	F05008-128	3
	IDLER ASSEMBLY, #60 POWER FEED CHAIN	034228	1
17	Plate Weldment, Power Feed Idler	034227	1
18	Spacer, 41/64" x 1" x 3/16"	S12480	1
19	Sprocket, 60BB13H x 5/8" Idler	034224	1
20	Bolt, 5/8-18 x 2 1/4" Hex Head Grade 5	F05009-80	1
21	Nut, 5/8-18 Nylon Lock	F05010-71	1
22	Bolt, 1/2-13 x 2" Socket Head	F05008-133	2
23	CHAIN, #60 X 278 1/4' POWER FEED	036195 ¹	1
24	LINK, #60 MASTER	042398	2

¹ Purchased chain 036195 replaces manufactured chain 042397 supplied prior to Rev. A2.00

7.4 Lower Track Rollers

LT70HD Remote

Rev. A3.00

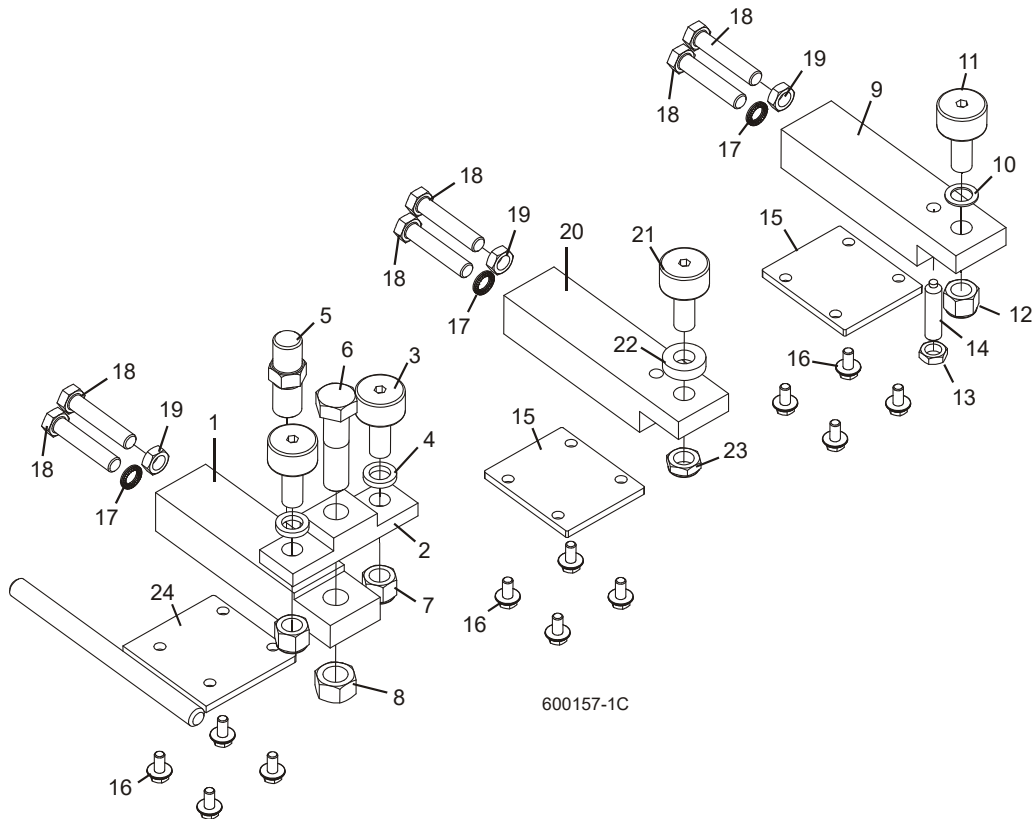

REF	DESCRIPTION (◆ Indicates Parts Available In Assemblies Only)	PART #	QTY.
	ROLLER ASSEMBLY, FRONT LOWER TRACK	036344	1
1	Block, Front Lower Track Roller Mount	036325	1
2	Block, Track Bearing Mount	042500	1
3	Bearing, 1 1/2" Track Roller	012797	2
4	Spacer, 41/64" x 1" x 3/16"	S12480	2
5	Pin, Safety Lock (Threaded)	036324	1
6	Bolt, 3/4-10 x 3" Hex Head Grade 5	F05013-5	1
7	Nut, 5/8-18 Hex Nylon Lock	F05010-101	2
8	Nut, 3/4-10 Hex Lock	F05010-80	1
	ROLLER ASSEMBLY, REAR LOWER TRACK	034232	1
9	Block, Rear Lower Track Roller Mount	034234	1
10	Shim, 5/8" x 1" x 1/16"	016510	1
11	Bearing, 1 1/2" Track Roller	012797	1
12	Nut, 5/8-18 Hex Jam	F05010-11	1
13	Nut, 1/2-13 Hex Jam	F05010-31	1
14	Screw, 1/2-13 x 2" Brass Tip Set	F05008-137	1

7

Power Feed System*Lower Track Rollers*

15	PLATE, LOWER TRACK ROLLER RETAINER	033880 ¹	2	
16	BOLT, 5/16-18 X 3/4" HEX HEAD W/FLAT & LOCK WASHER	F05006-101 ²	12	
17	WASHER, 1/2" NORD-LOCK	F05011-125 ²	3	
18	BOLT, 1/2-20 X 2 1/2" HEX HEAD FULL THREAD GRADE 5	F05008-135	6	
19	NUT, 1/2-20 HEX JAM	F05010-16	3	
	ROLLER ASSEMBLY, MIDDLE LOWER TRACK	017887	1	
20	Block, Lower Track Roller Mount	034234	1	
21	Bearing, 1 1/2" Track Roller	012797	1	
22	Spacer	034674	1	
23	Nut, 5/8-18 Nylon Lock Jam	F05010-101	1	
24	PLATE WELDMENT, FRONT LOWER TRACK ROLLER W/DEFLECTOR	036473 ¹	1	

¹ One Retainer Plate 033880 replaced with Deflector Weldment 036473 at front track roller to prevent assembly from catching on remote cable chain (Rev. A3.02).

² Bolt with lock and flat washer F05006-101 replaces 5/16" Split Lock Washer F05011-13 and Hex Head Bolt F05006-102, Nord-Lock Washer F05011-125 replaces F05011-9 1/2" Split Lock Washer supplied prior to 4/10. Hardware changes with mast side plate revision provides increased fastener durability.

7.5 Lower Track Rollers

LT70HD Remote

Rev. A1.00 - A2.04

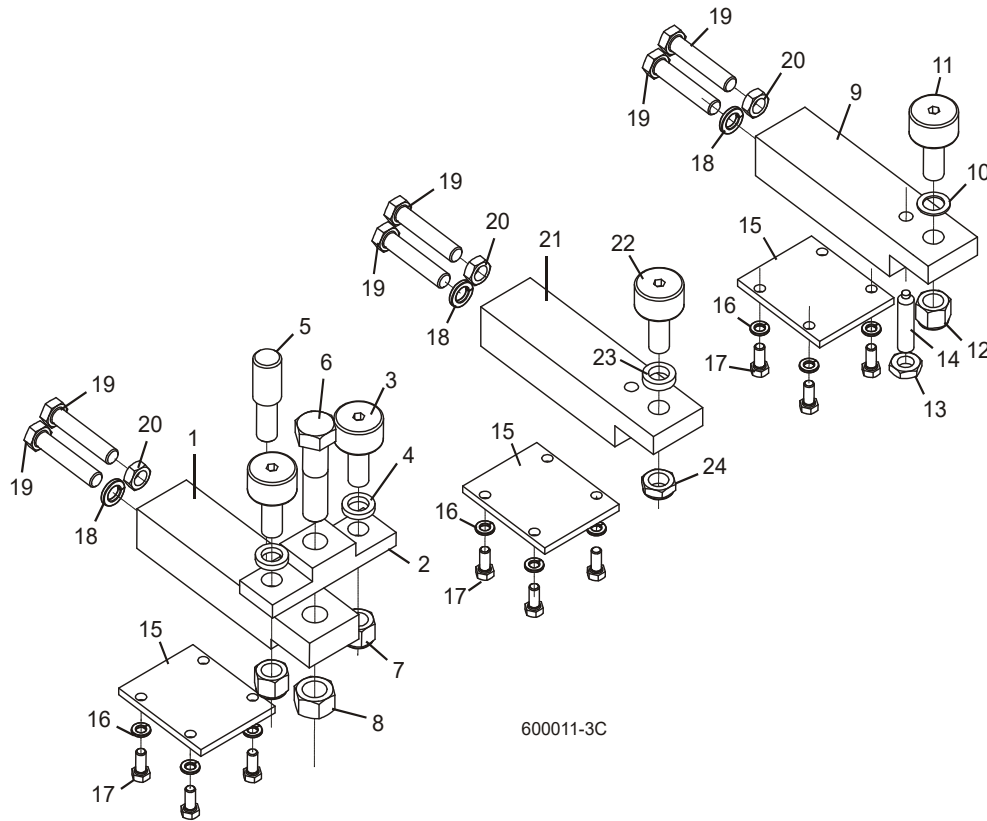

REF	DESCRIPTION (◆ Indicates Parts Available In Assemblies Only)	PART #	QTY.	
	ROLLER ASSEMBLY, FRONT LOWER TRACK	034233 ¹	1	◆
1	Block, Front Lower Track Roller Mount	034235	1	
2	Block, Track Bearing Mount	042500	1	
3	Bearing, 1 1/2" Track Roller	012797	2	
4	Spacer, 41/64" x 1" x 3/16"	S12480	2	
5	Pin, Safety Lock	042516	1	
6	Bolt, 3/4-10 x 3" Hex Head Grade 5	F05013-5	1	
7	Nut, 5/8-18 Hex Nylon Lock	F05010-101	2	
8	Nut, 3/4-10 Hex Lock	F05010-80	1	
	ROLLER ASSEMBLY, REAR LOWER TRACK	034232 ²	1	
9	Block, Rear Lower Track Roller Mount	034234	1	
10	Shim, 5/8" x 1" x 1/16"	016510	1	
11	Bearing, 1 1/2" Track Roller	012797	1	
12	Nut, 5/8-18 Hex Jam	F05010-11	1	
13	Nut, 1/2-13 Hex Jam	F05010-31 ²	1	
14	Screw, 1/2-13 x 2" Brass Tip Set	F05008-137 ²	1	

7

Power Feed System*Lower Track Rollers*

15	PLATE, LOWER TRACK ROLLER RETAINER	033880 ³	3	
16	WASHER, 5/16" SPLIT LOCK	F05011-13	12	
17	BOLT, 5/16-18 X 3/4" HEX HEAD	F05006-102	12	
18	WASHER, 1/2" SPLIT LOCK	F05011-9	3	
19	BOLT, 1/2-20 X 2 1/2" HEX HEAD FULL THREAD GRADE 5	F05008-135	6	
20	NUT, 1/2-20 HEX JAM	F05010-16	3	
	ROLLER ASSEMBLY, MIDDLE LOWER TRACK	017887 ⁴	1	
21	Block, Lower Track Roller Mount	034234	1	
22	Bearing, 1 1/2" Track Roller	012797	1	
23	Spacer	034674	1	
24	Nut, 5/8-18 Nylon Lock Jam	F05010-101	1	

¹ Roller Assembly 034233 obsolete. Service with component parts or replace with Roller Assembly 036344 with threaded safety lock pins ([See Section 7.4](#)).

² Set Screw F05008-137 and Jam Nut F05010-31 added to Rear Lower Roller Assembly 034232 Rev. A1.02.

³ One Retainer Plate 033880 replaced with Deflector Weldment 036473 at front track roller to prevent assembly from catching on remote cable chain ([See Section 7.4](#)).

⁴ Middle Track Roller Assembly 017887 added Rev. A1.02.

SECTION 8 BED FRAME ASSEMBLY

8.1 Bed Rail Assembly, Front And Rear

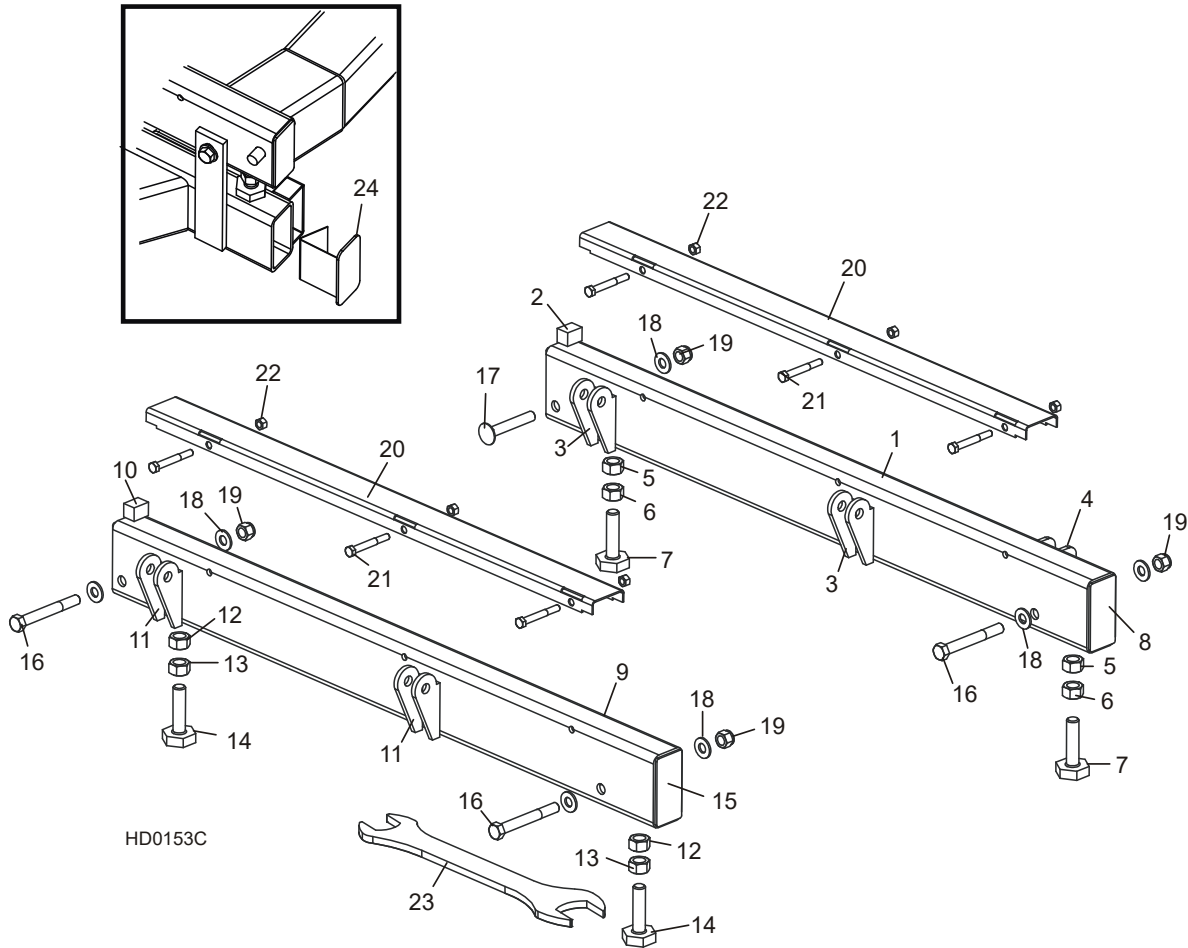

REF	DESCRIPTION (◆ Indicates Parts Available In Assemblies Only)	PART #	QTY.	
	BED RAIL ASSEMBLY, REAR PAINTED	014467	1	
1	Bed Rail Tube, Long	015974	1	◆
2	Block, Log Stop	S09034	1	
3	Bracket, Roller Toe Board Mount	S13021	4	◆
4	Bracket, Saw Head Rest Pin Mount	014150	2	◆
5	Nut, 5/8-11 Pilot Weld	F05010-84	2	
6	Nut, 5/8-11 Hex	F05010-5	2	
7	Bolt, Bed Rail Adjustment	S13006	2	
8	Plate, Bed Rail End Cap	S04058	2	◆
	BED RAIL ASSEMBLY, FRONT PAINTED	014455	1	
9	Bed Rail Tube, Long	015974	1	◆

8

Bed Frame Assembly*Bed Rail Assembly, Front And Rear*

10	Block, Log Stop	S09034	1	
11	Bracket, Roller Toe Board Mount	S13021	4	◆
12	Nut, 5/8-11 Pilot Weld	F05010-84	2	
13	Nut, 5/8-11 Hex	F05010-5	2	
14	Bolt, Bed Rail Adjustment	S13006	2	
15	Plate, Bed Rail End Cap	S04058	2	◆
16	BOLT, 1/2-13 X 4" HEX HEAD	F05008-78 ¹	3	
17	BOLT, 1/2-13 X 3 1/2" CARRIAGE	F05008-94 ²	1	
18	WASHER, 1/2" SAE FLAT	F05011-2	7	
19	NUT, 1/2-13 NYLON LOCK	F05010-8	4	
20	COVER, STAINLESS STEEL BED RAIL	016898	2	
21	BOLT, 5/16-18 X 2 1/2" HEX HEAD	F05006-10	6	
22	NUT, 5/16-18 HEX LOCK	F05010-6	6	
23	WRENCH, BED RAIL ADJUSTMENT	015970	1	
24	CAP WELDMENT, BED RAIL REMOVABLE END	014652	2	

¹ F05008-78 Grade 5 bolt replaces F05008-26 bolt originally supplied prior to 5/03.

² Used on rear bed rail to allow clearance for side support rollers.

8.2 Bed Rail Assembly, Middle Front

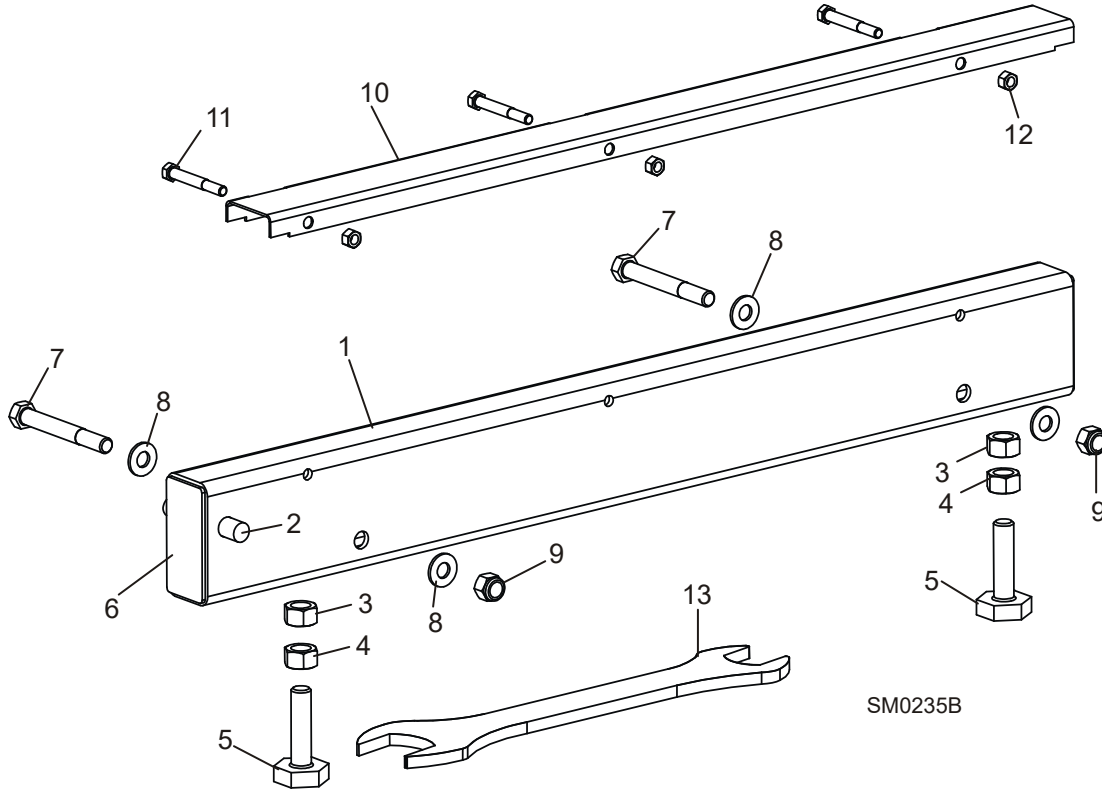

REF	DESCRIPTION (◆ Indicates Parts Available In Assemblies Only)	PART #	QTY.	
	BED RAIL ASSEMBLY, FRONT MIDDLE	A09566	1	
1	Bed Rail Tube, Short	S09103	1	◆
2	Pin, Ramp Mount	S04030	1	
3	Nut, 5/8-11 Pilot Weld	F05010-84	2	
4	Nut, 5/8-11 Hex	F05010-5	2	
5	Bolt, Bed Rail Adjustment	S13006	2	
6	Plate, Bed Rail End Cap	S04058	2	◆
7	BOLT, 1/2-13 X 4" HEX HEAD GRADE 5	F05008-78 ¹	2	
8	WASHER, 1/2" SAE FLAT	F05011-2	4	
9	NUT, 1/2-13 NYLON LOCK	F05010-8	2	
	COVER ASSEMBLY, STAINLESS STEEL BED RAIL (LONG)	A09956	1	
10	Cover, Stainless Steel Bed Rail	S09944	1	◆
11	Bolt, 5/16-18 X 2 1/2" Hex Head	F05006-10	3	
12	Nut, 5/16-18 Hex Lock	F05010-6	3	
13	WRENCH, BED RAIL ADJUSTMENT	015970	1	

¹ F05008-78 Grade 5 bolt replaces F05008-26 bolt originally supplied prior to 5/03.

8 Bed Frame Assembly

Bed Rail Assembly, Middle Rear

8.3 Bed Rail Assembly, Middle Rear

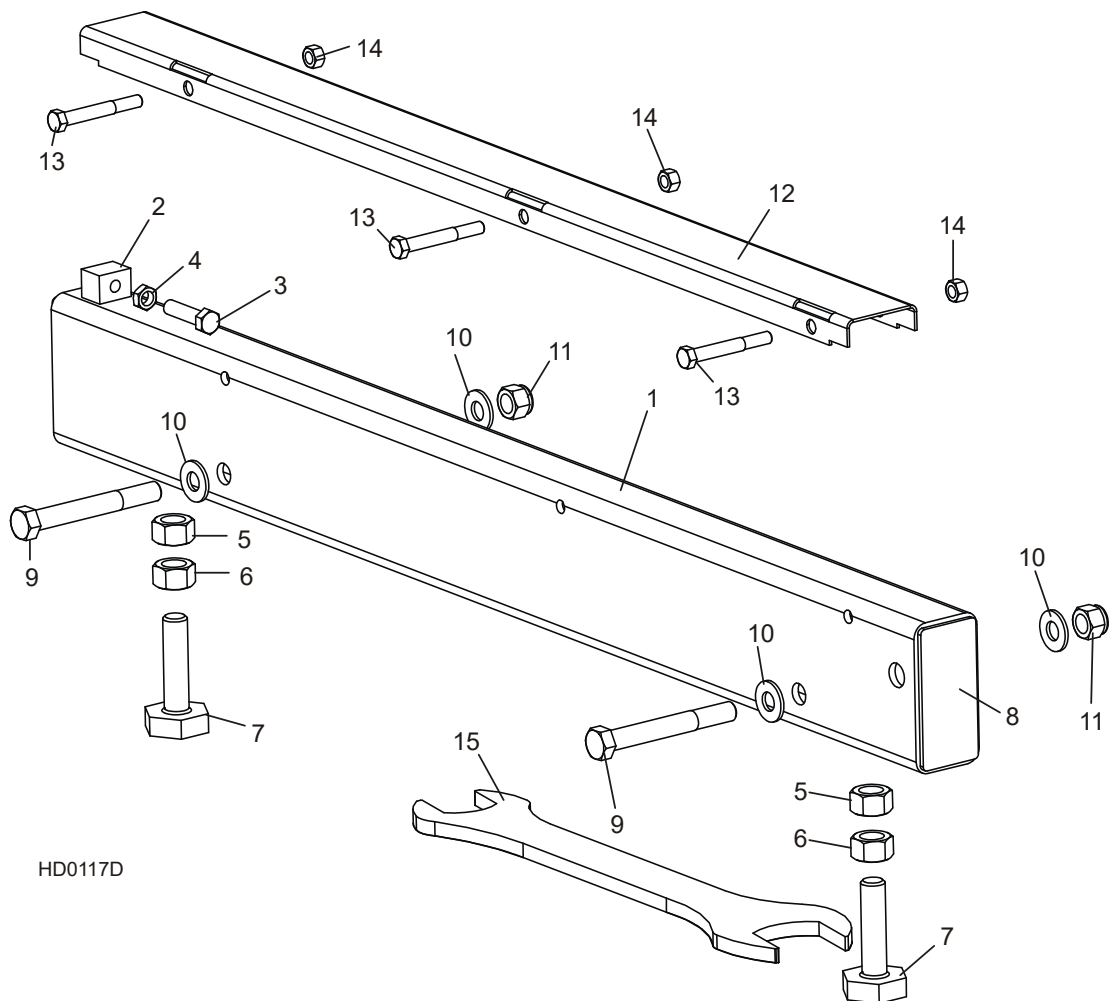

REF	DESCRIPTION (◆ Indicates Parts Available In Assemblies Only)	PART #	QTY.	
	BED RAIL ASSEMBLY, REAR MIDDLE PAINTED	015757	1	
1	Bed Rail Tube, Short	014640	1	◆
2	Block, Log Stop w/Threaded Hole	014639	1	◆
3	Bolt, 3/8-16 x 1 1/2 Full Thead Hex Head	F05007-17	1	
4	Nut, 3/8-16 Hex Jam	F05010-29	1	
5	Nut, 5/8-11 Pilot Weld	F05010-84	2	
6	Nut, 5/8-11 Hex	F05010-5	2	
7	Bolt, Bed Rail Adjustment	S13006	2	
8	Plate, Bed Rail End Cap	S04058	2	◆
9	BOLT, 1/2-13 X 4" HEX HEAD GRADE 5	F05008-78 ¹	2	
10	WASHER, 1/2" SAE FLAT	F05011-2	4	
11	NUT, 1/2-13 NYLON LOCK	F05010-8	2	

Bed Frame Assembly 8
Bed Rail Assembly, Middle Rear

	COVER ASSEMBLY, STAINLESS STEEL BED RAIL (LONG)	A09956	1	
12	Cover, Stainless Steel Bed Rail	S09944	1	◆
13	Bolt, 5/16-18 X 2 1/2" Hex Head	F05006-10	3	
14	Nut, 5/16-18 Hex Lock	F05010-6	3	
15	WRENCH, BED RAIL ADJUSTMENT	015970	1	

¹ F05008-78 Grade 5 bolt replaces F05008-26 bolt originally supplied prior to 5/03.

8 Bed Frame Assembly

Leg Assembly (Stationary)

8.4 Leg Assembly (Stationary)

LT15BS Rev. E.00+

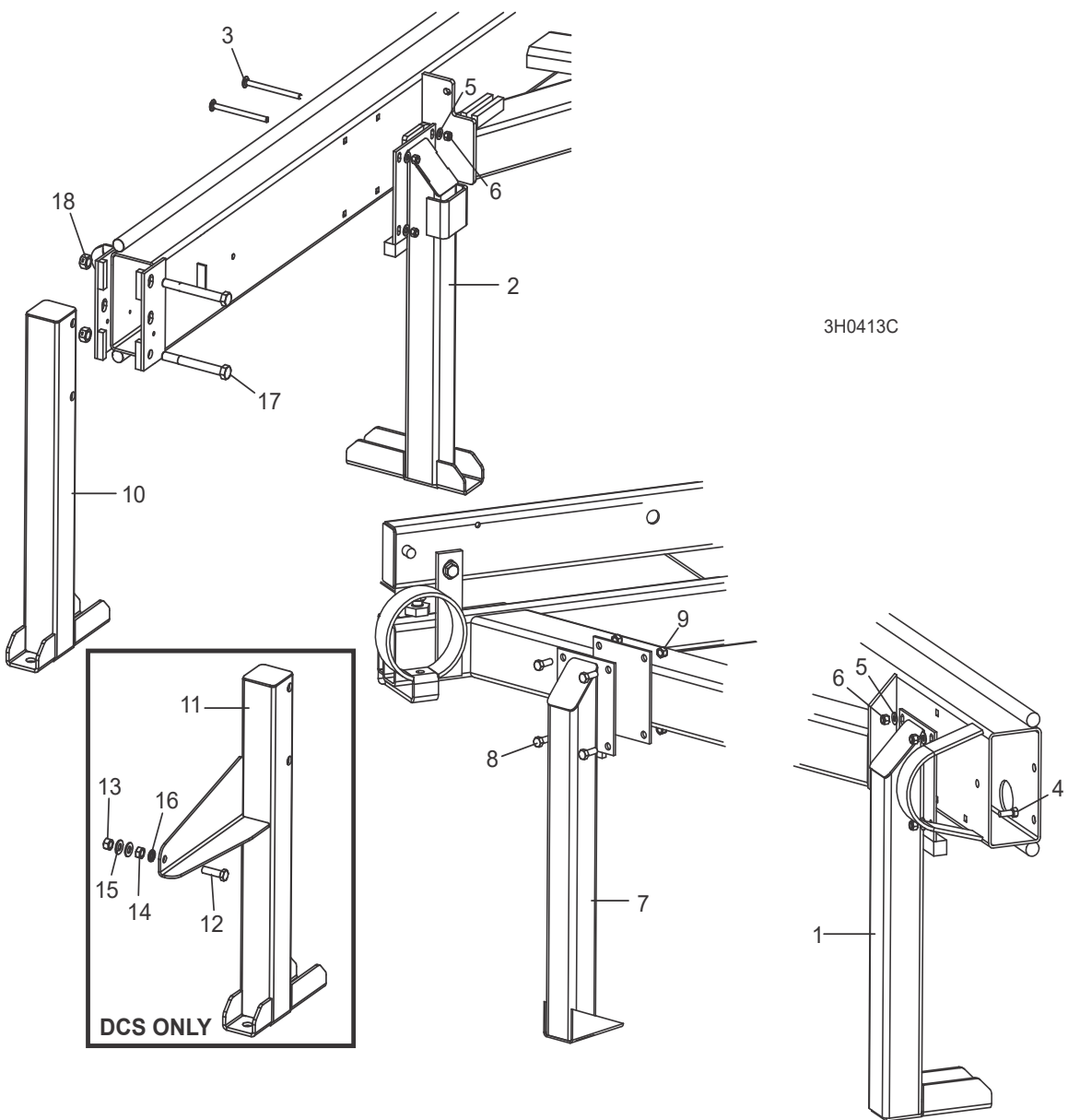

REF	DESCRIPTION (◆ Indicates Parts Available In Assemblies Only)	PART #	QTY.
1	LEG, LONG STATIONARY (1 REQ'D FOR LT60HD; 3 REQ'D FOR LT70HD)	W09513	1/3
2	LEG, LONG STATIONARY W/BOARD RETURN TABLE BRACKET	015091	1
3	BOLT, 3/8-16 X 5" CARRIAGE HEAD	F05007-113	8/12
4	BOLT, 3/8-16 X 1 1/4" HEX HEAD (REQ'D FOR REAR LT70HD ONLY)	F05007-2	4
5	WASHER, 3/8" SAE FLAT	F05011-3	8/16

Bed Frame Assembly
Leg Assembly (Stationary)

8

6	NUT, 3/8-16 HEX NYLON LOCK	F05010-10	8/16	
7	LEG, SHORT STATIONARY	W09515	2	
8	BOLT, 3/8-16 X 1 1/4" HEX HEAD	F05007-2	8	
9	NUT, 3/8-16 HEX NYLON LOCK	F05010-10	8	
10	LEG, FRONT STATIONARY	W09517	1	
11	BOLT, 5/8-11 X 5 1/2" HEX HEAD GRADE 5	F05009-11	2	
12	NUT, 5/8-11 HEX LOCK	F05010-4	2	

8 Bed Frame Assembly

Board Return Table Assembly

8.5 Board Return Table Assembly

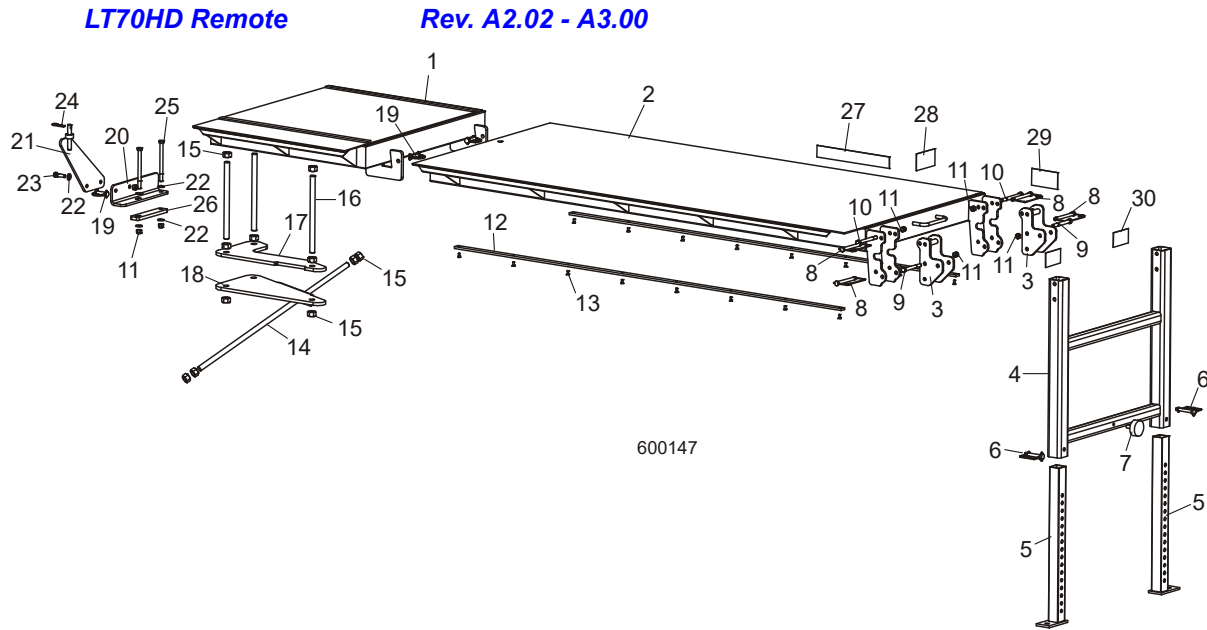

REF	DESCRIPTION (◆ Indicates Parts Available In Assemblies Only)	PART #	QTY.
	TABLE ASSEMBLY, BOARD	BT1 ¹	1
1	Table Weldment, Short Board	045826	1
2	Table Weldment, Long Board	045827	1
3	Plate Weldment, Table Pivot	046088	2
4	Mount Weldment, Table Leg	045839	1
5	Leg Weldment, Board Table	016651	2
6	Pin, 3/8" x 2 1/4" Wire Lock	014151	2
7	Bumper, Board Table	034175	1
8	Pin, 3/8" x 3 1/2" Wire Lock	046411	4
9	Bolt, 3/8-16 x 3 1/2" Hex Head Grade 5	F05004-123	2
10	Bolt, 3/8-16 x 4" Hex Head Full Thread Grade 5	F05007-92	2
11	Nut, 3/8-16 Hex Nylon Lock	F05010-10	7
12	Strip, 1/4" x 3/4" x 60"	046400	2
13	Screw, #10-24 x 1/2" Flat Socket Head	F05004-61	16
14	Rod, Board Table Support	046061	1
15	Nut, 5/8-11 Hex	F05010-5	13
16	Rod, 5/8-11 Threaded	045844	3
17	Plate, Upper Board Table Clamp	045832	1
18	Plate, Lower Board Table Clamp	045833	1
19	Pin, 3/8" x 1 3/8" Wire Lock	046412	3
20	Bracket, Board Table Mount	046091	1
21	Pin Weldment, Board Table Mount	046095	1

Bed Frame Assembly
Board Return Table Assembly **8**

22	Washer, 3/8" SAE Flat	F05011-3	5	
23	Bolt, 3/8-16 x 1 1/4" Hex Head Grade 5	F05007-123	1	
24	Pin, 1/8" x 1 13/16" Safety Retaining	P05059	1	
25	Bolt, 3/8-16 x 5 Hex Head Grade 5	F05007-86	2	
26	Bracket, Lower Table Mount Clamp	046099	1	
27	Decal, Wood-Mizer Logo 1 1/2"	016991	1	
28	Decal, Secure Table Warning	046410	1	
29	Decal, Board Return Danger	015365	1	
30	Decal, Hand Pinch Point Warning	S12641	2	

¹ BT1 replaces 045825 originally supplied (part number change only). BT1 modified to reduce parts and cost 11/04.

8 Bed Frame Assembly

Board Return Table Assembly

8.6 Board Return Table Assembly

LT70HD Remote

Rev. A1.00 - A2.01

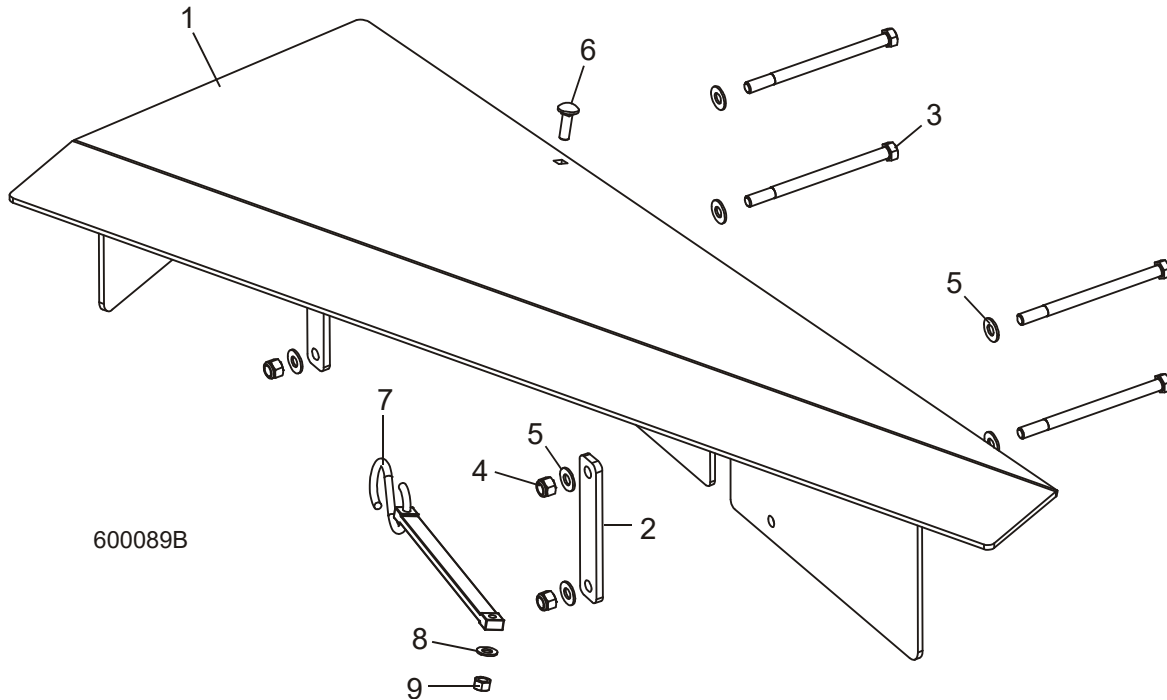

REF	DESCRIPTION (◆ Indicates Parts Available In Assemblies Only)	PART #	QTY.	
	TABLE ASSEMBLY, BED	017819	1	
1	Table Weldment, Bed	017817	1	◆
2	Plate, Bed Table Strap	017818	2	
3	Bolt, 3/8-16 x 5 1/2" Hex Head Grade 5	F05007-34	4	
4	Nut, 3/8-16 Hex Nylon Lock	F05010-10	4	
5	Washer, 3/8" SAE Flat	F05011-3	8	
6	Bolt, 5/16-18 x 1" Carriage Head	F05006-9	1	
7	Strap, 11 1/2" Rubber	012965 ¹	1	
8	Washer, 5/16" SAE Flat	F05011-17	1	
9	Nut, 5/16-18 Hex Lock	F05010-6	1	

¹ Strap and mounting hardware added to secure pivot bed rail to prevent rail from hitting control box during travel (Rev. A1.07).

8.7 Pivot Bed Rail Assembly

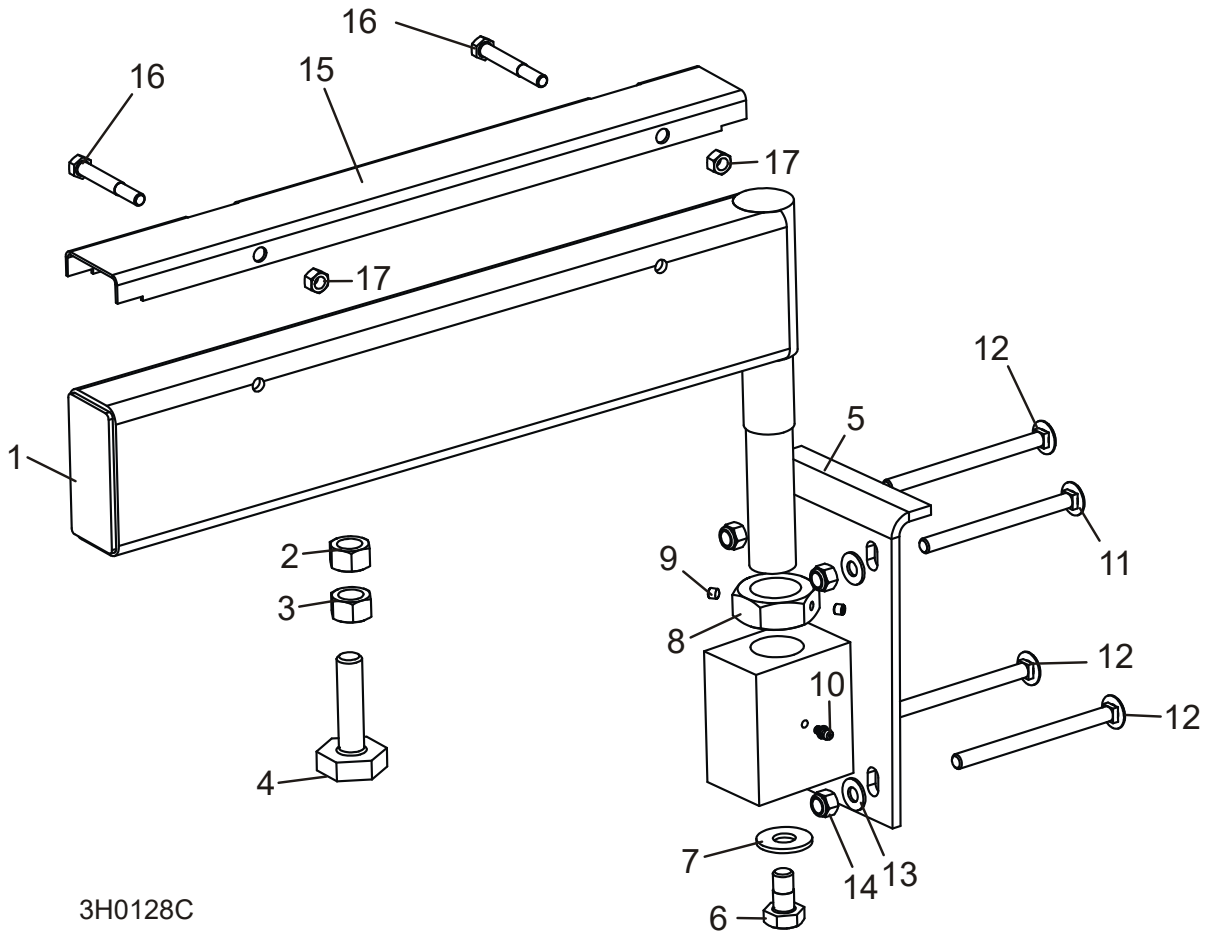

3H0128C

REF	DESCRIPTION (◆ Indicates Parts Available In Assemblies Only)	PART #	QTY.	
	PIVOT BED RAIL ASSEMBLY (LT70HD)	A13015	2	
1	Pivot Bed Rail Weldment (LT70HD)	W13014	1	◆
2	Nut, 5/8-11 Pilot Weld	F05010-84	2	
3	Nut, 5/8-11 Hex	F05010-5	2	
4	Bolt, Bed Rail Adjustment	S13006	2	
5	Bracket, Pivot Rail Mounting	W13090	1	
6	Bolt, 1/2-13 x 1" Hex Head Grade 2	F05008-50	1	
7	Washer, 9/16" SAE Flat	F05011-52	1	
8	Nut, Pivot Rail Adjustment	S13016	1	
9	Screw, 1/4-28 x 1/4" Brass Tip Set	F05005-42	2	
10	Fitting, 3/16" Grease	P04107	1	
11	BOLT, 3/8-16 X 4 3/4" CARRIAGE HEAD	F05007-114	2	
12	BOLT, 3/8-16 X 5" CARRIAGE HEAD	F05007-113	6	
13	WASHER, 3/8" SAE FLAT	F05011-3	8	

8**Bed Frame Assembly***Pivot Bed Rail Assembly*

14	NUT, 3/8-16 NYLON LOCK	F05010-10	8	
	COVER KIT, PIVOT RAIL STAINLESS STEEL (LT70HD)	017710	2	
15	Cover, Stainless Steel Pivot Bed Rail (LT70HD)	S13012	1	
16	Bolt, 5/16-18 X 2 1/2" Hex Head	F05006-10	2	
17	Nut, 5/16-18 Hex Lock	F05010-6	2	
	WRENCH, BED RAIL ADJUSTMENT (See Section 8.1)	015970	1	

8.8 Log Side Support Assembly (Manual)

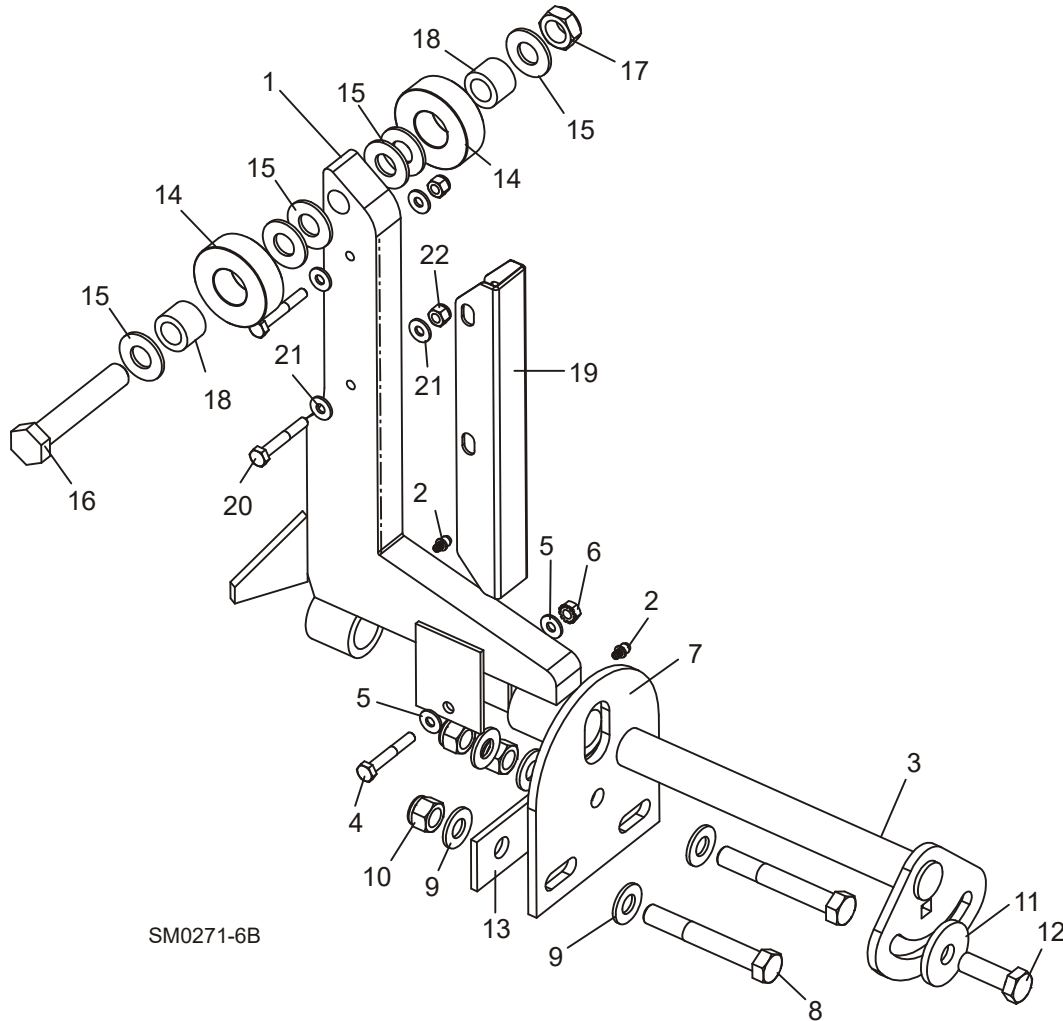

REF	DESCRIPTION (◆ Indicates Parts Available In Assemblies Only)	PART #	QTY.
1	SUPPORT, LOG SIDE	015235	2
2	Fitting, 3/16" Grease	P04107	2
	MOUNTING KIT, LOG SIDE SUPPORT	016559	2
3	Pin, Log Side Support Pivot	016544	1
4	Bolt, 1/4-20 X 1 1/2" Hex Head Grade 5	F05005-4	1
5	Washer, 1/4" SAE Flat	F05011-11	2
6	Nut, 1/4-20 Self Locking	F05010-9	1
7	Plate, Log Side Support End	016555	1
8	Bolt, 1/2-13 X 3 1/2" Hex Head Grade 5	F05008-61	2
9	Washer, 1/2" SAE Flat	F05011-2	5
10	Nut, 1/2-13 Hex Nylon Lock	F05010-8	3

8

Bed Frame Assembly*Log Side Support Assembly (Manual)*

11	Washer, .52" x 1.69"	014632 ¹	1	
12	Bolt, 1/2-13 X 1 1/2" Hex Head Grade 5	F05008-33	1	
13	Plate, Side Support Washer Clamp	016558	1	
	ROLLER KIT, SIDE SUPPORT (OPTIONAL)	016562	4	
14	Roller, Side Support	016561	2	
15	Washer, 5/8" SAE Flat	F05011-5 ²	6	
16	Bolt, 5/8-11 x 3 3/4" Hex Head Grade 5	F05009-118 ³	1	
17	Nut, 5/8-11 Hex Nylon Lock Jam	F05010-96 ⁴	1	
18	Bushing, Bronze 5/8" x 1" x 3/4"	016560	2	
	Bolt, 1/2-13 x 3 1/2" Carriage Head	F05008-94	1	
	Instruction Sheet, Side Support Roller	016562-526	1	
	GUARD KIT, STAINLESS STEEL SIDE SUPPORT	016798	1	
19	Guard, Stainless Steel Side Support	016722	4	
20	Bolt, 1/4-20 x 1 3/4" Hex Head	F05005-4	8	
21	Washer, 1/4" SAE Flat	F05011-11	16	
	Washer, 5/8" SAE Flat	F05011-5 ²	4	
22	Nut, 1/4-20 Hex Nylon Lock	F05010-69	8	
	Instruction Sheet, Stainless Steel Side Support Guard Retro	016798-1005	1	

¹ Oversized Washer 014632 replaces 1/2" SAE Flat Washer F05011-2 to provide larger clamping area during adjustment (12/09).

² Additional 5/8" SAE Flat Washer F05011-5 may be required on each side of side support to provide clearance for optional stainless steel side support guards. Extra washers are included in the stainless steel guard retrofit kit (016798).

³ Longer bolt replaces 3 1/2" F05009-93 used before 3/07.

⁴ Replaces F05010-4 Hex Lock Nut used prior to 9/06 for ease of assembly.

8.9 Safety Chain Assembly

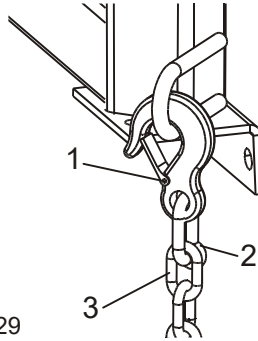

REF	DESCRIPTION (◆ Indicates Parts Available In Assemblies Only)	PART #	QTY.	
	CHAIN ASSEMBLY, TIE DOWN	A04376	1	
1	Hook, 5/8" Safety Chain	P12075	1	◆
2	Cold Shut, 3/8" Plain	P04772-2	1	◆
3	Chain, 5/16" Unplated	R02111	.938 ft.	◆

8 **Bed Frame Assembly**
Saw Head Rest Pin Assembly

8.10 Saw Head Rest Pin Assembly

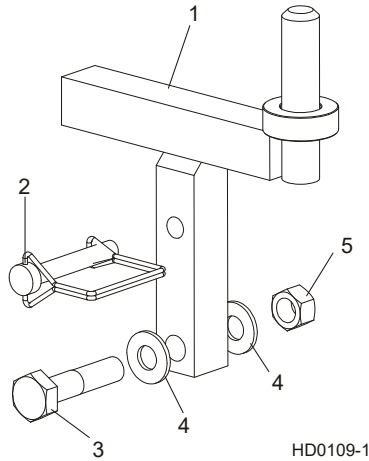

REF	DESCRIPTION (◆ Indicates Parts Available In Assemblies Only)	PART #	QTY.	
1	PIN, SAW HEAD REST	034442	1	
2	PIN, 3/8" X 2 1/4" SNAP RETAINER	014151	1	
3	BOLT, 1/2-13 X 2 1/4" HEX HEAD GRADE 5	F05008-10	1	
4	WASHER, 1/2" SAE FLAT	F05011-2	2	
5	NUT, 1/2-13 HEX LOCK	F05010-3	1	

8.11 Bed Frame Decals

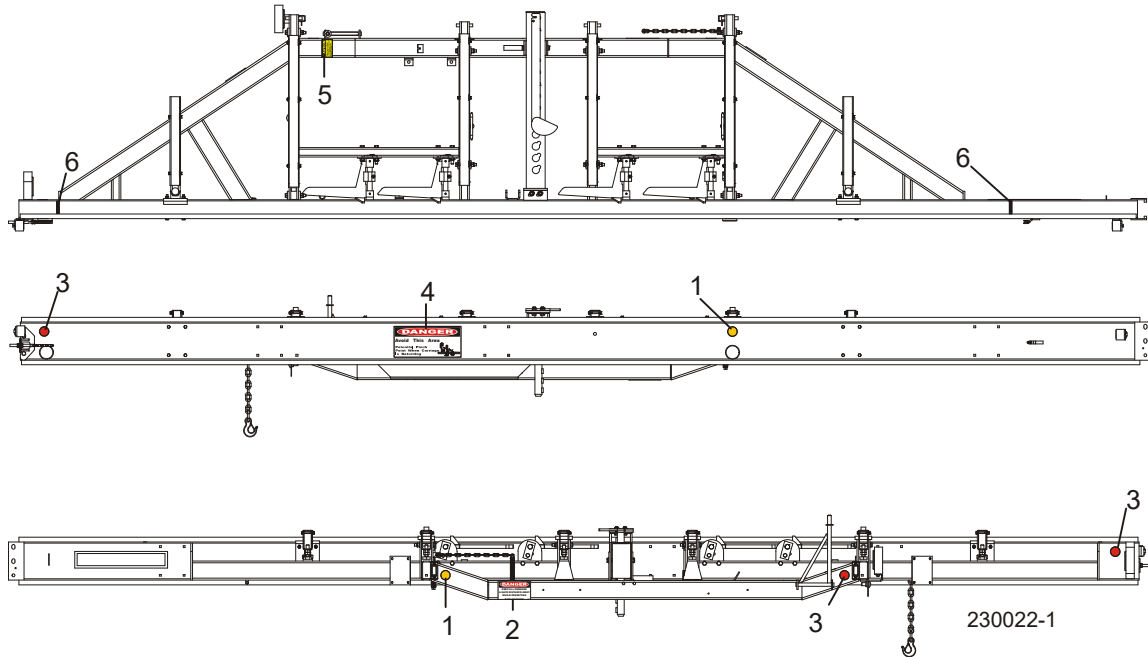

REF	DESCRIPTION (◆ Indicates Parts Available In Assemblies Only)	PART #	QTY.
1	DECAL, AMBER REFLECTIVE 2" ROUND	P07453	2
2	DECAL, KEEP AWAY DANGER	S09851	1
3	DECAL, RED REFLECTIVE 2" ROUND	P07452	3
4	DECAL, PINCH POINT DANGER	P10287	1
5	DECAL, SAW HEAD REST CAUTION	S12581	1
6	DECAL, LOG LIMIT STRIPE	S12051	2

8.12 Cable Chain Assembly

LT70HD Remote

Rev. A1.09 - A3.00

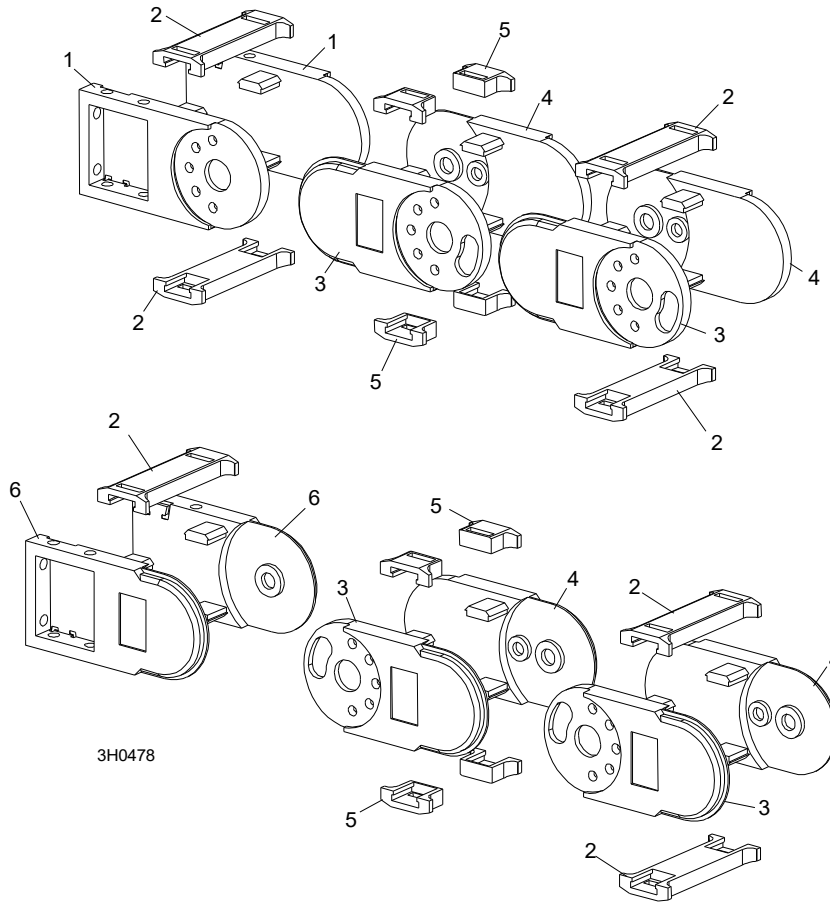

REF	DESCRIPTION (◆ Indicates Parts Available In Assemblies Only)	PART #	QTY.
	CHAIN ASSEMBLY, NYLON REMOTE 196" #4040C	042753	1
1	Link, Nylon Chain Top Mount	023612-3	2
2	Brace, Nylon Chain Long Cross	023612-4	55
3	Link, Nylon Chain Right Side #4040C	036217 ¹	52
4	Link, Nylon Chain Left Side #4040C	036218 ¹	52
5	Brace, Nylon Chain Short Cross	023612-5	104
6	Link, Nylon Chain Bottom Mount	023612-9	2

¹ Use 036217 and 036218 to service chain equipped with Rev. C side plates only (plate ID #4040C.01.150 & #4040C.02.150).
See [Section 8.13](#) for Rev. B service parts.

8.13 Cable Chain Assembly

LT70HD Remote

Rev. A1.00 - A1.08

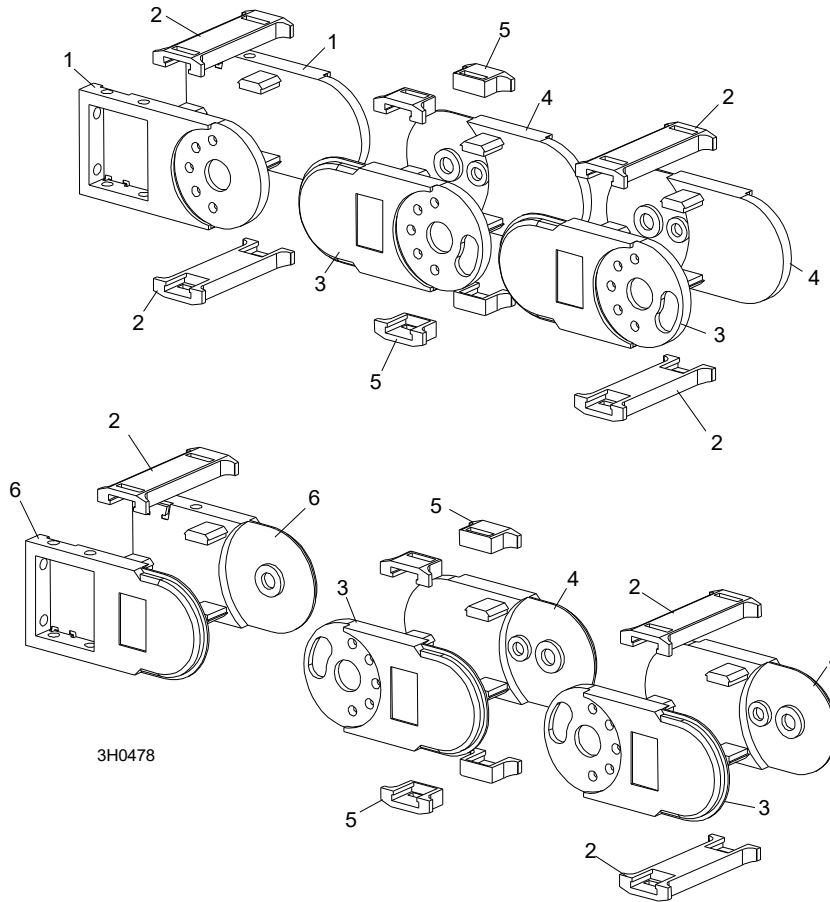

REF	DESCRIPTION (◆ Indicates Parts Available In Assemblies Only)	PART #	QTY.
	CHAIN ASSEMBLY, NYLON REMOTE 196" #4040C	042753 ¹	1
1	Link, Nylon Chain Top Mount	023612-3	2
2	Brace, Nylon Chain Long Cross	023612-4	55
3	Link, Nylon Chain Right Side #4040B	016865-1 ¹	52
4	Link, Nylon Chain Left Side #4040B	016865-2 ¹	52
5	Brace, Nylon Chain Short Cross	023612-5	104
6	Link, Nylon Chain Bottom Mount	023612-9	2

¹ Chain assembly 042753 side plates revised to Rev. C by vendor 3/03. Use 016865-1 and 016865-2 to service original chain side plates (plate ID #4040B.01.150 & #4040B.02.150). [See Section 8.12](#) to service chain equipped with Rev. C side plates (plate ID #4040C.01.150 & #4040C.02.150).

8 Bed Frame Assembly

Bottom Chain Mount Assembly

8.14 Bottom Chain Mount Assembly

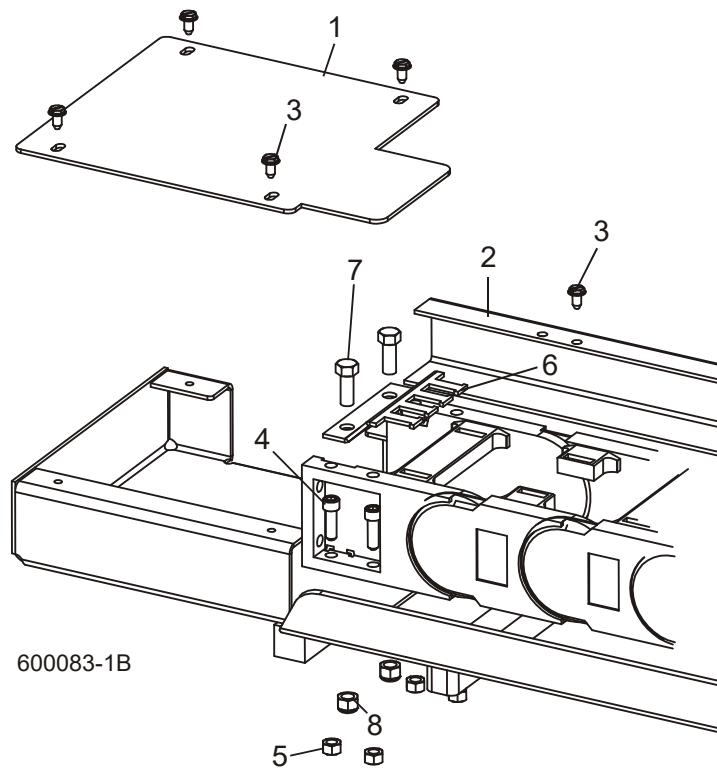

REF	DESCRIPTION (◆ Indicates Parts Available In Assemblies Only)	PART #	QTY.
1	PLATE, CHAIN BOX COVER	015578	1
2	WIREWAY, 32 1/16" CABLE	017747 ¹	1
3	SCREW, 1/4-20 X 1/2" SLOTTED HEX HEAD	F05015-1	7
4	BOLT, 5/16-18 X 1" SOCKET HEAD	F05006-19 ²	4
5	NUT, 5/16-18 HEX LOCK	F05010-6 ²	4
6	BRACKET, WIRE ROUTING	023604	1
7	BOLT, 3/8-16 X 1" HEX HEAD	F05007-7	2
8	NUT, 3/8-16 NYLON LOCK	F05010-10	2

¹ Replaces 017951 supplied prior to 4/03 (similar parts).

² Mounting hardware replaces F05006-82 5/16-18 x 4 1/2" Hex Head Bolt, F05011-16 Flat Washer and F05010-58 Nylon Lock Nut originally used prior to Rev. A3.02 to provide clearance for new track roller deflector ([See Section 7.4](#)).

8.15 Top Chain Mount Assembly

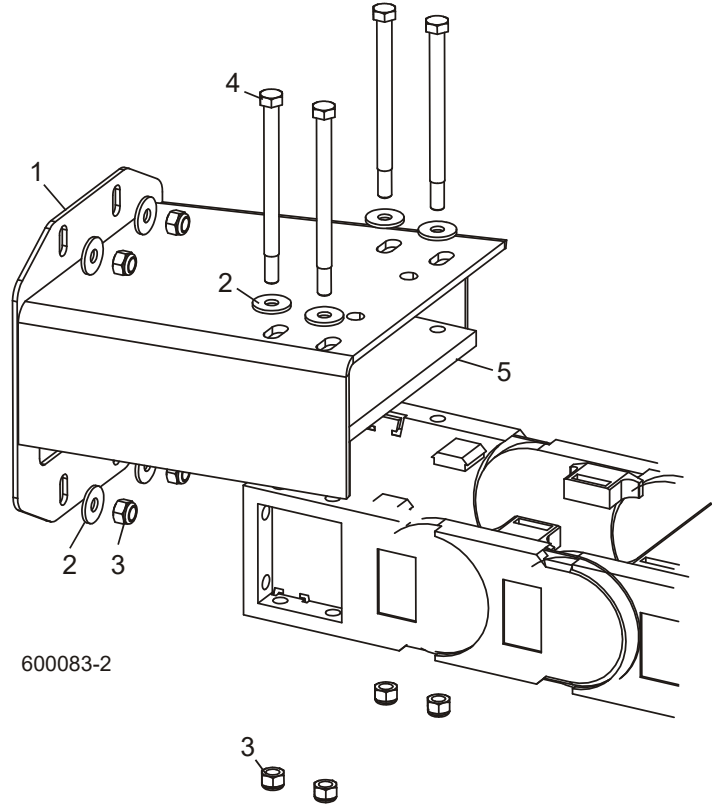

REF	DESCRIPTION (◆ Indicates Parts Available In Assemblies Only)	PART #	QTY.
1	BRACKET WELDMENT, TOP CABLE CHAIN MOUNTING	034387	1
2	WASHER, 5/16" STANDARD FLAT	f05011-16	8
3	NUT, 5/16-18 NYLON LOCK	f05010-58	8
4	BOLT, 5/16-18 X 4 1/2" HEX HEAD	F05006-82	4
5	PLATE, CABLE CHAIN SPACER	023606 ¹	1

¹ Spacer plate removed Rev. A2.04. Part not needed.

8 **Bed Frame Assembly**
Front Tray Mount Assembly

8.16 Front Tray Mount Assembly

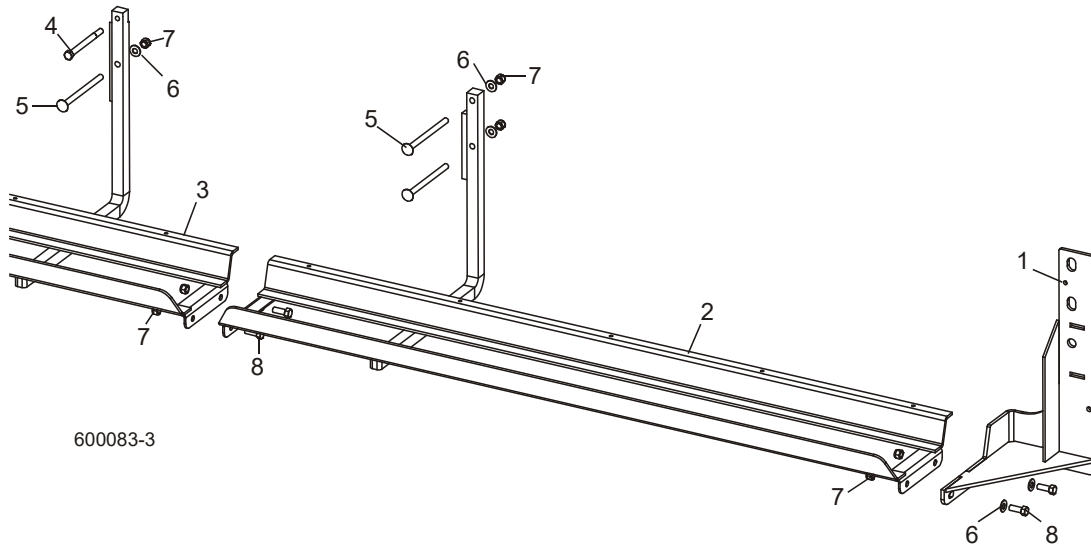

REF	DESCRIPTION (◆ Indicates Parts Available In Assemblies Only)	PART #	QTY.
1	BRACKET WELDMENT, LT70HD CABLE CHAIN	034875	1
2	TRAY WELDMENT, LT70HD 53 13/16" EXTENSION	042747	1
3	TRAY WELDMENT, LT70HD CABLE CHAIN	042746	1
4	BOLT, 3/8-16 X 4 1/2" HEX HEAD	F05007-35	1
5	BOLT, 3/8-16 X 5 1/2" CARRIAGE HEAD	F05007-31	9
6	WASHER, 3/8" SAE FLAT	F05011-3	11
7	NUT, 3/8-16 NYLON LOCK	F05010-10	13
8	BOLT, 3/8-16 X 1" HEX HEAD	F05007-7	4

8.17 Cable Chain Support Bracket

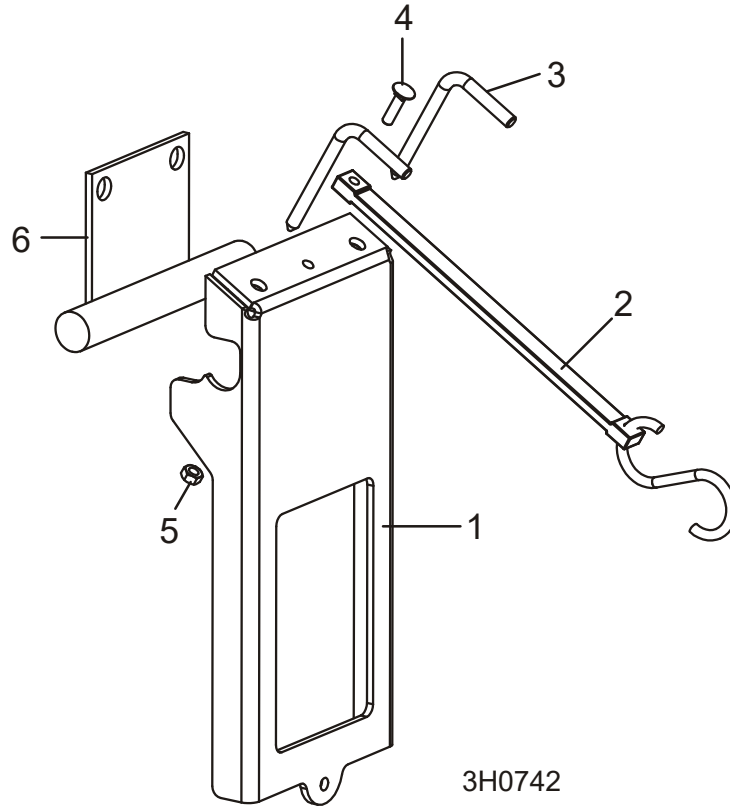

REF	DESCRIPTION (◆ Indicates Parts Available In Assemblies Only)	PART #	QTY.	
	BRACKET ASSEMBLY, REMOTE CABLE CHAIN SUPPORT	023586	1	
1	Bracket Weldment, Remote Cable Chain Support	023588	1	◆
2	Strap, 11 1/2" Rubber	012965	1	
3	Handle, Remote Cable Chain Support Lock	023602	2	
4	Bolt, 1/4-20 x 1" Carriage Head	F05005-34	1	
5	Nut, 1/4-20 Hex Lock	F05010-21	1	
6	BRACKET WELDMENT, CHAIN SUPPORT STORAGE	023589	1	

8.18 Remote Cable Box

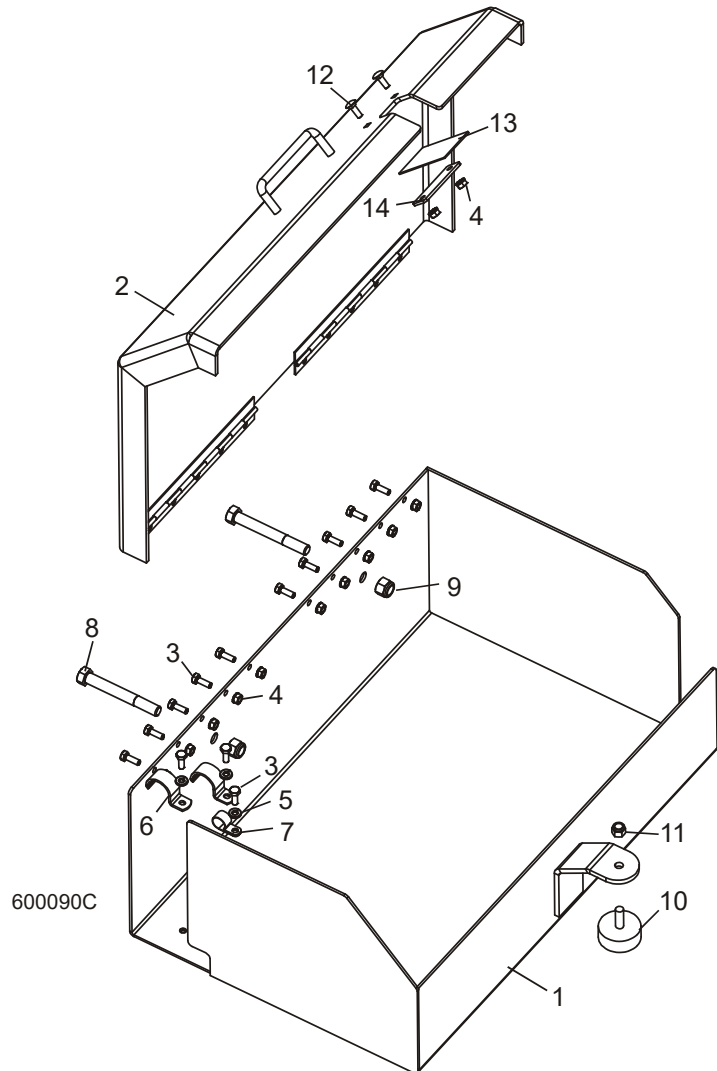

REF	DESCRIPTION (◆ Indicates Parts Available In Assemblies Only)	PART #	QTY.	
	BOX ASSEMBLY, REMOTE CABLE	034792	1	
1	Box Weldment, Remote Cable	034790	1	◆
2	Lid Weldment, Remote Cable Box	034791	1	
3	Bolt, 1/4-20 x 3/4" Hex Head	F05005-1	13	
4	Nut, 1/4-20 Self-Locking	F05010-9	12	
5	Washer, 1/4" Split Lock	F05011-14	3	
6	Clamp, 1" EMT	P05436 ¹	2	
7	Clamp, 5/8" EMT	010748 ²	1	
8	Bolt, 1/2-13 x 4" Hex Head Grade 5	F05008-78	2	
9	Nut, 1/2-13 Hex Nylon Lock	F05010-8	2	

Bed Frame Assembly 8

Remote Cable Box

10	Bumper, Table	034175	1	
11	Nut, 3/8-16 Hex Nylon Lock	F05010-10	1	
12	Bolt, 1/4-20 x 3/4" Carriage Head	F05005-113	2	
13	Flap, 2" x 3 5/8" Rubber	017958	1	
14	Plate, 1" x 3"	017959	1	

¹ 1" EMT Clamp P05436 replaces two 3/4" Clamps P04851 and one 1/2" Clamp P05088 (11/02).

² 5/8" EMT Clamp 010748 replaces one 1" EMT Clamp P05436 to match size of cable being secured (5/03).

SECTION 9 MISCELLANEOUS

9.1 Replacement Manuals

REF	DESCRIPTION (◆ Indicates Parts Available In Assemblies Only)	PART #	QTY.
Wood-Mizer Product Information			
1	ALL-PRODUCTS CATALOG	PS750	1
Basic Sawmill Manuals			
2	TRU-SHARP BLADE HANDBOOK	M600	1
3	WOOD-MIZER GENERAL INFORMATION	M601	1
4	LT70HD REMOTE OPERATOR'S MANUAL	M1054	1
5	LT70HD REMOTE PARTS MANUAL	M1056	1
Power Option Manuals			
6	E25 MOTOR OPTION MANUAL	M1082	1
7	D42 ENGINE OPTION MANUAL	M1067	1
8	D51 ENGINE OPTION MANUAL	M1146	1
9	D62 ENGINE OPTION MANUAL	M1138	1
10	KUBOTA OPERATOR'S MANUAL	028555	1
11	KUBOTA SERVICE MANUAL	028566	1
12	KUBOTA PARTS MANUAL (1505TE)	028565	1
Trailer Option Manuals			
13	CLASS IV ELECTRIC BRAKE TRAILER OPTION (DIESEL REMOTE ONLY)	M1114	1
14	SUPER ELECTRIC BRAKE TRAILER OPTION	M797	1
15	SUPER SURGE BRAKE TRAILER OPTION	M795	1
Miscellaneous Option Manuals			
16	SHINGLE/LAPSIDER OPTION MANUAL	M621	1
17	RESAW ATTACHMENT OPTION MANUAL	M263	1
18	BED EXTENSION OPTION MANUAL	M294	1
19	DEBARKER OPTION MANUAL (DC)	M1059	1
20	DEBARKER OPTION MANUAL (AC)	M1105	1
21	REMOTE ACCUSET OPTION MANUAL	M1112	1
22	LASER SIGHT OPTION MANUAL	M1081	1
23	LUBE-MIZER OPTION MANUAL	M885	1
Electrical Diagrams			
24	E25-H REMOTE ELECTRICAL INFORMATION	M1089	1
25	E25-L REMOTE ELECTRICAL INFORMATION	M1091	1
26	E25-C REMOTE ELECTRICAL INFORMATION	M1093	1
27	D51 ELECTRICAL INFORMATION	M1164	1
28	D42 REMOTE ELECTRICAL INFORMATION	M1103	1
29	D51/D62 REMOTE ELECTRICAL INFORMATION	M1140	1

SECTION 10 HYDRAULIC SYSTEM

10.1 Hydraulic Hoses

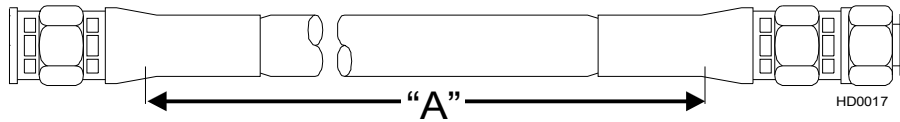

ID	Color Code	LENGTH "A"	Application	HOSE PART #
H1	Purple	81"	1/4" Rear Toe Board Top	048306
H2	Black	87"	1/4" Rear Toe Board Base	048307
H3	Yellow	52"	1/4" Front Toe Board Top	048308
H4	Gray	56"	1/4" Front Toe Board Base	048309
H5	Green	43"	1/4" Clamp Up/Down Top	048310
H6	Yellow	32"	1/4" Clamp Up/Down Base	048311 ¹
H7	Red	22"	3/8" Loading Arm Base	048312
H8	Blue	22"	3/8" Loading Arm Top	048312
H9	Red	14"	3/8" Side Support Base	048313
H10	Pink	12"	3/8" Side Support Top	048314
H11	Orange	18"	3/8" Clamp In/Out Base	048315
H12	White	21"	3/8" Clamp In/Out Top	048316
H13	Green	72"	3/8" Loading Arm Branch Top	048317
H14	Green	36"	3/8" Loading Arm Branch Top	048318
H15	Yellow	77"	3/8" Loading Arm Branch Base	048298 ¹
H16	Yellow	36"	3/8" Loading Arm Branch Base	048318
H17	Pink	58"	3/8" Log Turner Base	048319
H18	Plain	66"	3/8" Log Turner Top	048320
H19	Purple	67"	3/8" Log Turner Motor Top	048321
H20	Black	71"	3/8" Log Turner Motor Base	048322

¹ Hose extended 2" 2/07 to improve routing.

10.2 Command Control

LT70HD Remote

Rev. A1.09 - A3.00

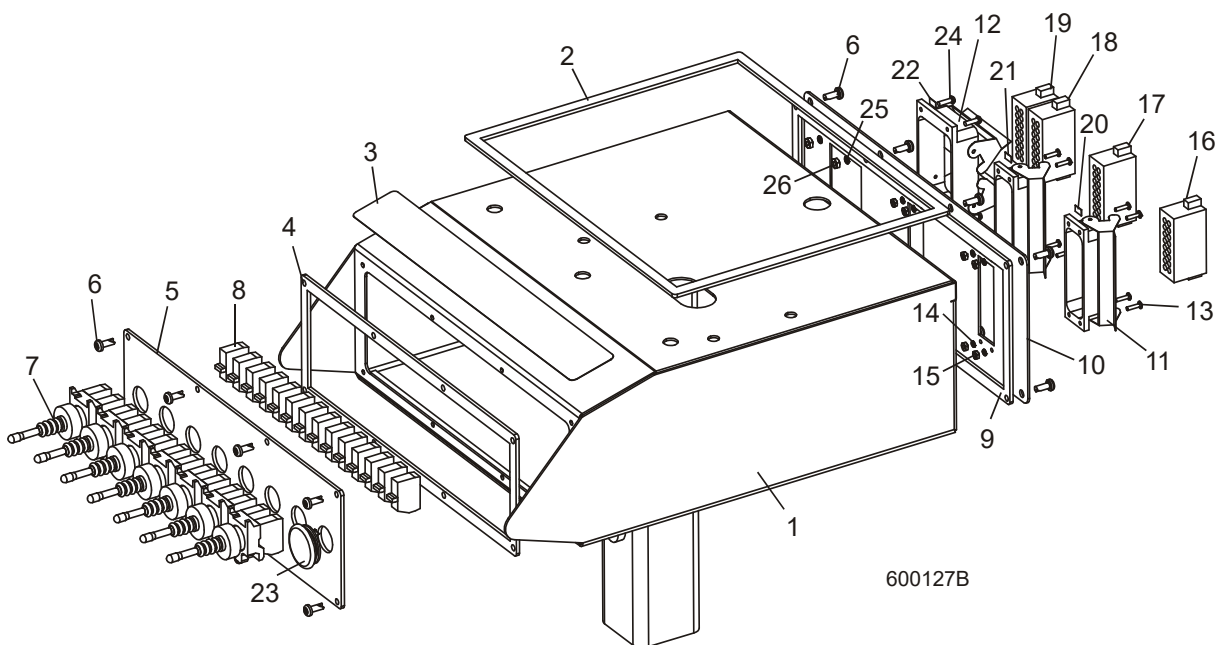

REF	DESCRIPTION (◆ Indicates Parts Available In Assemblies Only)	PART #	QTY.
	BOX ASSEMBLY, LT70 REMOTE DC HYDRAULIC CONTROL	050962 ¹	1
	BOX ASSEMBLY, LT70 REMOTE AC HYDRAULIC CONTROL	050963 ¹	1
1	Box Weldment, LT70 Remote Hydraulic Control	017891	1
2	Gasket, Top Hydraulic Control	045349	1
3	Decal, LT70 Remote Hydraulic Control	038407	1
4	Gasket, Front Hydraulic Control	045347	1
5	Panel, Front Hydraulic Control	034647	1
6	Screw, #10-24 x 1/2" Phillips Pan Head Type 23	F05015-17	16
7	Switch, Joystick w/2 NO Contacts	050766	7
8	Contact, NO ZD4 PA103	052075 ²	14
9	Gasket, Rear Hydraulic Control	045348	1
10	Panel, Rear Hydraulic Control	017927 ¹	1
11	Connector, 16 Pin Panel Mount Single Lever	E23103	2
12	Connector, 32 Pin Panel Mount Dual Lever	050828 ¹	1
13	Screw, #4-40 x 1/2" Slotted Round Head	F05004-14	12
14	Washer, #4 Split Lock	F05011-21	12
15	Nut, #4-40 Hex	F05010-43	12
	Connector Assembly, LT70D42-R 1-16 M	050779	1
	Connector Assembly, LT70E25-R 1-16 M	050798	1
16	Insert, Male 10A 16 Pin Screw Terminals 1-16	E23105	1

	Connector Assembly, LT70D42-R 17-32 M	050780	1	
	Connector Assembly, LT70E25-R 17-32 M	050799	1	
17	Insert, Male 10A 16 Pin Screw Terminals 17-32	015670	1	
	Connector Assembly, LT70 Remote Hydraulic	050964 ¹	1	
18	Insert, Male 10A 16 Pin Screw Terminals 17-32	015670	1	
19	Insert, Male 10A 16 Pin Screw Terminals 1-16	E23105	1	
20	Decal, Connector ID J1A	038409	1	
21	Decal, Connector ID J2A	038410	1	
22	Decal, Connector ID J3A	038411	1	
23	Plug, AS075 Oiltite Painted	024250	1	
24	Screw, #6-32 x 1/2" Slotted Round Head	F05015-24 ³	4	
25	Washer, #6 Split Lock	F05011-78	4	
26	Nut, #6-32 Hex	F05010-44	4	

¹ New control boxes include new rear panel, dual connector and harness to accommodate additional log deck option joystick.

² Contact 052075 replaces 050539 NO ZB4 BE101 originally supplied.

³ #6 screws, washers & nuts replace #4 hardware previously used to mount 32-pin connector prior to 2/04.

10.3 Command Control

LT70HD Remote

Rev. A1.00 - A1.08

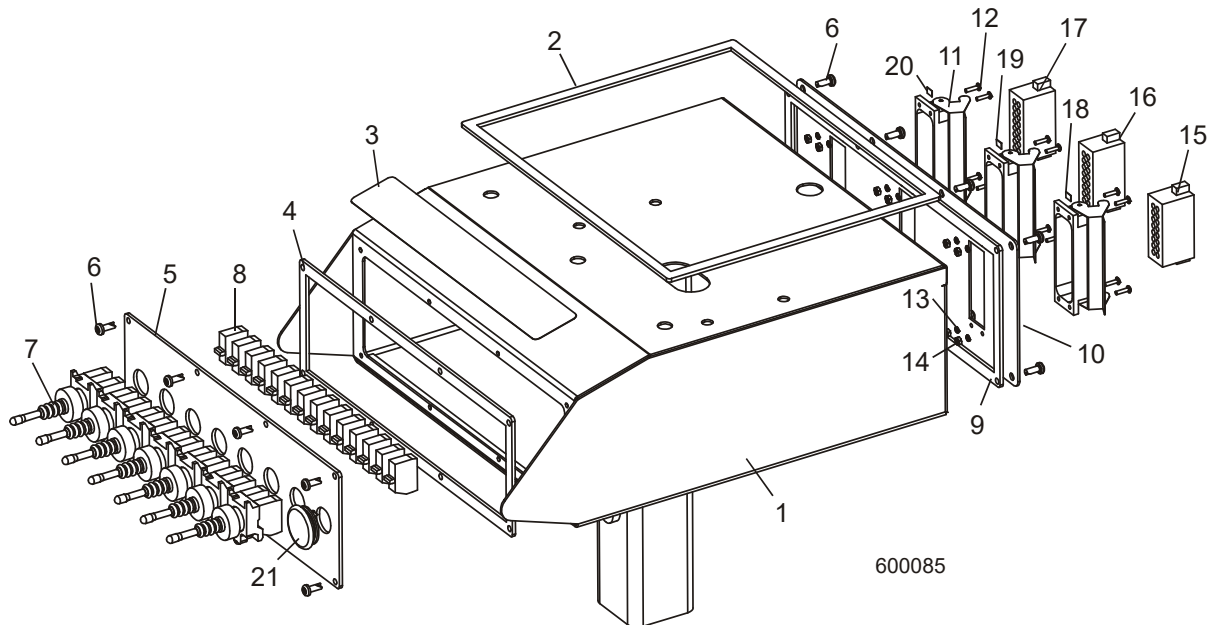

REF	DESCRIPTION (◆ Indicates Parts Available In Assemblies Only)	PART #	QTY.
	BOX ASSEMBLY, LT70 REMOTE DC HYDRAULIC CONTROL	050765 ¹	1
	BOX ASSEMBLY, LT70 REMOTE AC HYDRAULIC CONTROL	050800 ¹	1
1	Box Weldment, LT70 Remote Hydraulic Control	017891	1
2	Gasket, Top Hydraulic Control	045349	1
3	Decal, LT70 Remote Hydraulic Control	038407	1
4	Gasket, Front Hydraulic Control	045347	1
5	Panel, Front Hydraulic Control	034647	1
6	Screw, #10-24 x 1/2" Phillips Pan Head Type 23	F05015-17	16
7	Switch, Joystick w/2 NO Contacts	050766	7
8	Contact, NO ZD4 PA103	052075 ²	14
9	Gasket, Rear Hydraulic Control	045348	1
10	Panel, Rear Hydraulic Control	017893 ¹	1
11	Connector, 16 Pin Panel Mount Single Lever	E23103 ¹	3
12	Screw, #4-40 x 1/2" Slotted Round Head	F05004-14	12
13	Washer, #4 Split Lock	F05011-21	12
14	Nut, #4-40 Hex	F05010-43	12
	Connector Assembly, LT70D42-R 1-16 M	050779	1
	Connector Assembly, LT70E25-R 1-16 M	050798	1
15	Insert, Male 10A 16 Pin Screw Terminals 1-16	E23105	1

	Connector Assembly, LT70D42-R 17-32 M	050780	1	
	Connector Assembly, LT70E25-R 17-32 M	050799	1	
16	Insert, Male 10A 16 Pin Screw Terminals 17-32	015670	1	
	Connector Assembly, LT70 Remote Hydraulic	050778 ¹	1	
17	Insert, Male 10A 16 Pin Screw Terminals 1-16	E23105	1	
18	Decal, Connector ID J1A	038409	1	
19	Decal, Connector ID J2A	038410	1	
20	Decal, Connector ID J3A	038411	1	
21	Plug, AS075 Oiltite Painted	024250	1	

¹ Control boxes replaced with new assemblies that include new rear panel, dual connector and harness to accommodate additional log deck option joystick (Rev. A1.09 - [See Section 10.2](#)).

² Contact 052075 replaces 050539 NO ZB4 BE101 originally supplied.

10 Hydraulic System

Hydraulic Pump Box (DC)

10.4 Hydraulic Pump Box (DC)

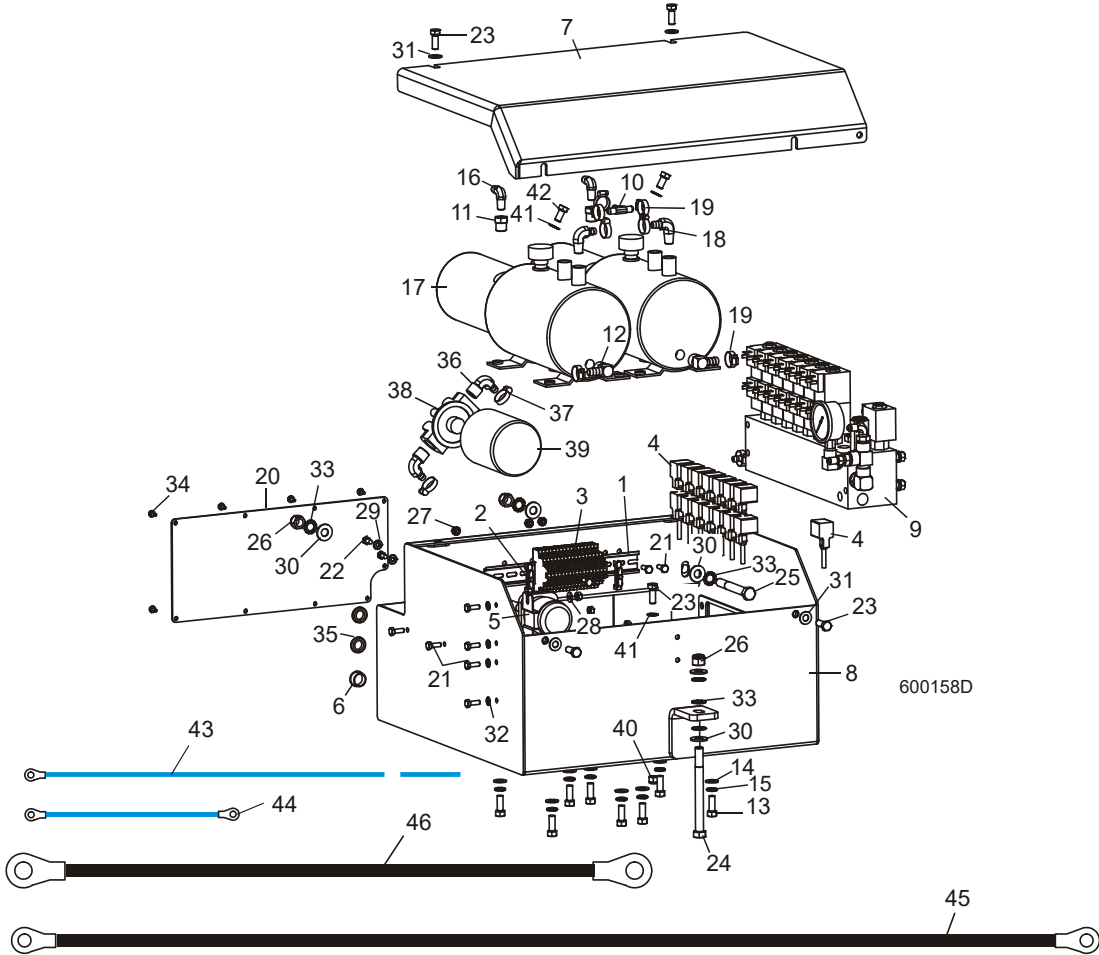

REF	DESCRIPTION (◆ Indicates Parts Available In Assemblies Only)	PART #	QTY.
	TERMINAL BLOCK ASSEMBLY, LT70 DC REMOTE HYDRAULIC	050794	1
1	Rail, 35mm x 7.5mm x 11" Steel DIN	024474-11	1
2	Clamp, Metal DIN Rail	E22707	2
3	Terminal Block, 3-Tier	024908	18
4	Plug Assembly, 2-Cond w/E GND DIN A 53950	050829	15
	BOX ASSEMBLY, LT60/70 DC REMOTE HYDRAULIC PUMP	034638	1
5	Solenoid Kit, 200A 12V SPST Hydraulic Motor	016371	2
	Solenoid, 200A 12V SPST Cont. Duty	015470	1 ◆
	Diode Assembly, Solenoid Coil Chassis Gnd	015426 ¹	1
6	Plug, 7/8" Dia. Plastic	016424	1
7	Plate, Hydraulic Pump Box Top	034636	1
8	Box Weldment, Hydraulic Pump	034637	1
9	Valve Parts (See Section 10.8)		

	Pump Assembly, LT60/70 DC Remote Hydraulic	034654	1	
10	Fitting, 3/8" Hose Barb Tee	015485	1	
11	Fitting, 3/8" NPT x 1/4" NPT Reducer	015490	2	
12	Fitting, 1/2" NPT x 1/2" Hose Barb Elbow	015997	2	
13	Bolt, 3/8-16 x 1" Hex Head	F05007-7	8	
14	Washer, 3/8" SAE Flat	F05011-3	8	
15	Washer, 3/8" Split Lock	F05011-4	8	
16	Fitting, 1/4" NPT x 1/4" JIC Elbow	P09142	2	
17	Pump Kit, Hydraulic w/Motor	061764 ²	2	
	Pump, Hydraulic Replacement Monarch Model #12070	016199	1	
	Motor Kit, Hydraulic Replacement	052807	1	
	Motor, 12 VDC Hydraulic Pump #08714 (Iskra)	038683 ³	1	◆
	Brush Kit, 4-Valve Hydraulic Pump Motor #08658-I (Iskra)	038682 ³	1	
	Brush Kit, 4-Valve Hydraulic Pump Motor #08658	P09585 ³	1	◆
	Bearing, Base Motor #02318	P12513	1	
	Wire Assembly, Motor Brush Ground	052806 ⁴	1	
	Cap, Hydraulic Pump Vented Fill #03171	P12817	1	
	O-Ring, Hydraulic Pump/Reservoir #02352	P10198	1	
	Seal, Hydraulic Pump/Motor #02330	P10315	1	
18	Fitting, 3/8" NPT x 3/8" Hose Barb Elbow	P12708	2	
19	Clamp, 11/16" Hose	P12739	7	
20	Plate, Hydraulic Pump Box Rear	034795	1	
21	Bolt, 1/4-20 x 3/4" Hex Head Full Thread	F05005-1	9	
22	Bolt, 1/4-20 x 1/2" Hex Head	F05005-15	2	
23	Bolt, 3/8-16 x 1" Hex Head Grade 5	F05007-87 ⁵	5	
24	Bolt, 1/2-13 x 5 1/2" Hex Head Grade 5	F05008-28 ⁶	1	
25	Bolt, 1/2-13 x 4" Hex Head Grade 5	F05008-78	2	
26	Nut, 1/2-13 Hex Nylon Lock	F05010-8	3	
27	Nut, 1/4-20 Hex Self-Locking	F05010-9	9	
28	Washer, 1/4" SAE Flat	F05011-11	4	
29	Washer, 1/4" Split Lock	F05011-14	2	
30	Washer, 1/2" SAE Flat	F05011-2	3	
31	Washer, 3/8" SAE Flat	F05011-3	4	
32	Washer, 1/4" Exterior Star Lock	F05011-37	4	
33	Washer, 1/2" Exterior Star Lock	F05011-39 ⁶	3	
34	Bolt, #10-24 x 1/2" Self-Tapping	F05015-7	9	
35	Grommet, 5/8" ID Rubber	P11764	2	
36	Fitting, 1/2" NPT x 3/8" Hose Barb Elbow	P12707	2	
37	Clamp, 11/16" Hose Clamp	P12739	2	
38	Manifold, Hydraulic Filter w/Cartridge	P22683	1	
39	Filter, S28 Hydraulic Cartridge	P20301	1	
40	Nut, 3/8-16 Hex Nylon Lock	F05010-10	1	

10

Hydraulic System

Hydraulic Pump Box (DC)

41	Washer, 3/8" External Star Lock	F05011-36 ⁶	3	
42	Bolt, 3/8-16 x 1" Hex Head	F05007-27 ⁶	2	
43	WIRE ASSEMBLY, 14 GA X 48" REMOTE SOLENOID	036316	2	
44	WIRE ASSEMBLY, 14 GA X 4" #10 RING TERMINALS	036314	1	
45	CABLE ASSEMBLY, 1 GA X 30" HYDRAULIC PUMP TO SOLENOID	036313	2	
46	CABLE ASSEMBLY, 1 GA X 16" HYDRAULIC PUMP GROUND	036312	2	

¹ Diode Assembly 015426 added to prevent damage to hydraulic microswitch (8/04).

² Pump Kit 061764 replaces Pump P12701 1/09. Kit includes P12701 plus Brush Ground Wire Kit 052805 to insure adequate ground connection.

³ Bosch motor P09955 replaced by vendor with Iskra motor 038683 1/06. Brush kit P09585 no longer available to service Bosch motor. Replace motor using kit 052807. Use Brush Kit 038682 to service Iskra motor.

⁴ Brush Ground Wire 052806 added 7/06 to improve ground connection. Kit 052805 to be supplied to all customers who purchased sawmills with Iskra pump motors after 1/06. Kit includes wire, hardware and instructions (One kit required per pump).

⁵ F05007-87 Grade 5 bolt replaces F05007-7 bolt supplied before 5/03.

⁶ Bolt and Star Lock Washers added/reoriented to improve electrical grounding of assembly (Rev. A1.07).

10.5 Hydraulic Pump Box (AC)

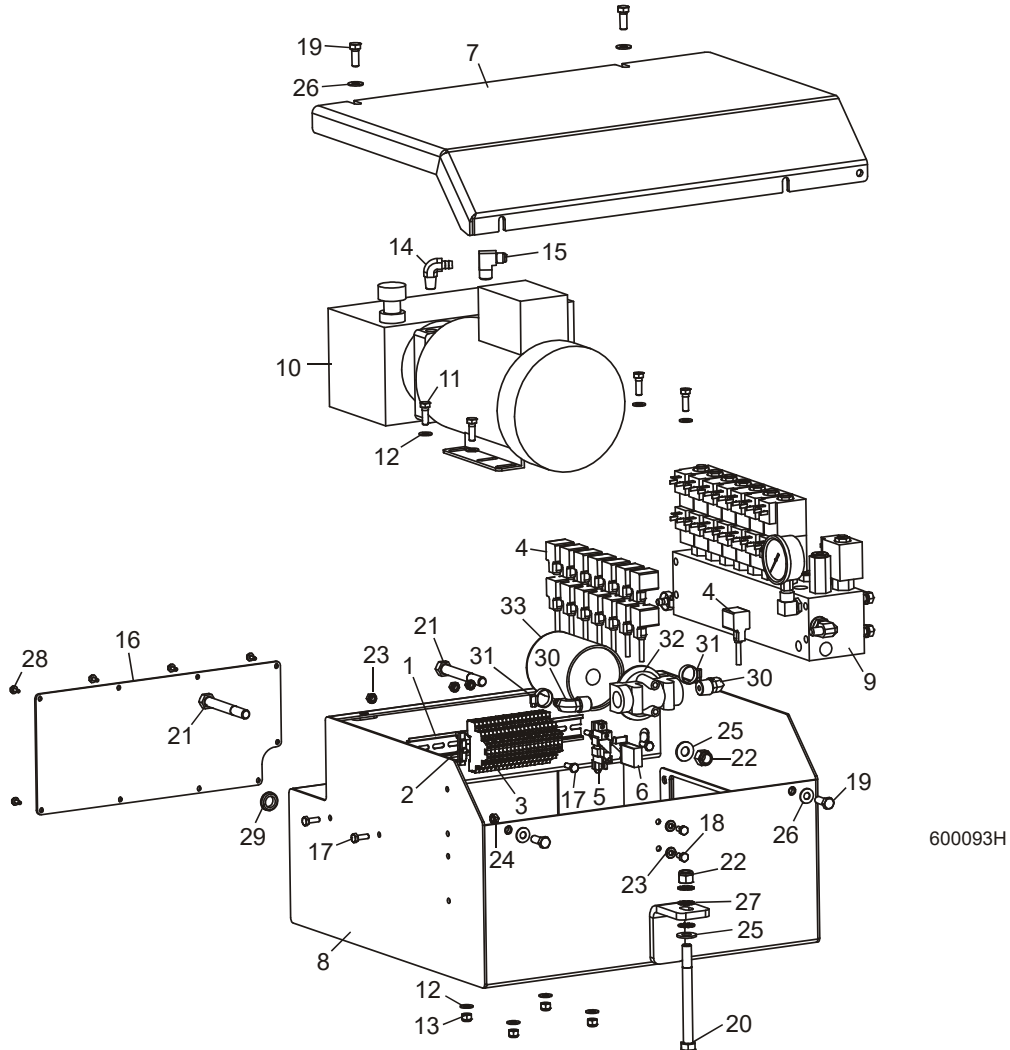

REF	DESCRIPTION (◆ Indicates Parts Available In Assemblies Only)	PART #	QTY.
	TERMINAL BLOCK ASSEMBLY, LT70 AC REMOTE HYDRAULIC	050808	1
1	Rail, 35mm x 7.5mm x 11" Steel DIN	024474-11	1
2	Clamp, Metal DIN Rail	E22707	2
3	Terminal Block, 3-Tier	024908	19
4	Plug Assembly, 2-Cond w/E GND DIN A 53950	050829	15
5	Relay Socket, DIN NR41	050897	1
6	Relay, SPDT Type R Miniature	050896	1
	BOX ASSEMBLY, LT60/70 AC REMOTE HYDRAULIC PUMP	017880	1
7	Plate, Hydraulic Pump Box Top	034636	1
8	Box Weldment, Hydraulic Pump	034637	1
9	Valve Parts (See Section 10.9)		

10

Hydraulic System

Hydraulic Pump Box (AC)

10	Pump, Hydraulic AC w/Tank	034457 ¹	1	◆
11	Bolt, 5/16-18 x 1" Hex Head	F05006-1	4	
12	Washer, 5/16" SAE Flat	F05011-17	8	
13	Nut, 5/16-18 Nylon Lock	F05010-58	4	
14	Fitting, 3/8" NPT x 3/8" Hose Barb Elbow	P12708	1	
15	Fitting, 3/8" NPT x 3/8" JIC Elbow	016820	1	
16	Plate, Hydraulic Pump Box Rear	034795	1	
17	Bolt, 1/4-20 x 3/4" Hex Head Full Thread	F05005-1	5	
18	Bolt, 1/4-20 x 1/2" Hex Head	F05005-15	2	
19	Bolt, 3/8-16 x 1" Hex Head Grade 5	F05007-87 ²	4	
20	Bolt, 1/2-13 x 5 1/2" Hex Head Grade 5	F05008-28 ³	1	
21	Bolt, 1/2-13 x 4" Hex Head Grade 5	F05008-78	2	
22	Nut, 1/2-13 Hex Nylon Lock	F05010-8	3	
23	Nut, 1/4-20 Hex Self-Locking	F05010-9	5	
24	Washer, 1/4" Split Lock	F05011-14	2	
25	Washer, 1/2" SAE Flat	F05011-2	3	
26	Washer, 3/8" SAE Flat	F05011-3	4	
27	Washer, 1/2" Exterior Star Lock	F05011-39 ³	3	
28	Bolt, #10-24 x 1/2" Self-Tapping	F05015-7	9	
29	Grommet, 5/8" ID Rubber	P11764	2	
30	Fitting, 1/2" NPT x 3/8" Hose Barb Elbow	P12707 ⁴	2	
31	Clamp, 11/16" Hose Clamp	P12739	2	
32	Manifold, Hydraulic Filter w/Cartridge	P22683	1	
33	Filter, S28 Hydraulic Cartridge	P20301	1	

¹ Motor/Pump/Tank Assembly 034457 discontinued by vendor. Use assembly 054824 for service. Replacement requires modification or replacement of pump box 036777 with appropriate mounting holes ([See Form #1501](#)).

² F05007-87 Grade 5 bolt replaces F05007-7 bolt supplied before 5/03.

³ Star Lock Washers relocated and Bolt reoriented (Rev. A1.07).

⁴ One P12707 replaces Hex Reducer Fitting 028073 and Straight Hose Barb Fitting P12724 to improve routing of return hoses (Rev. A1.06).

10.6 Hydraulic Control Box (230/460V AC)

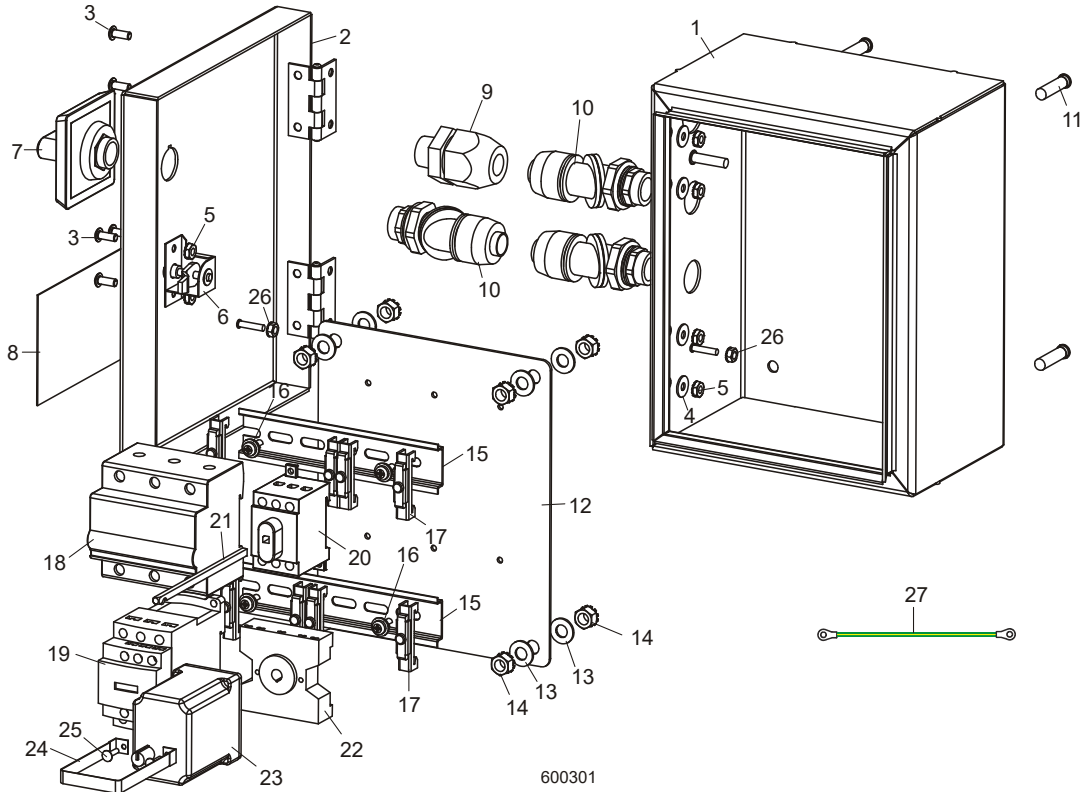

600301

REF	DESCRIPTION (◆ Indicates Parts Available In Assemblies Only)	PART #	QTY.
	CONTROL ASSEMBLY, LT70 E25-L REMOTE HYDRAULIC	050900	1
	CONTROL ASSEMBLY, LT70 E25-H REMOTE HYDRAULIC	050899	1
1	Box Weldment, Hydraulic AC Control	050302	1
2	Door Weldment, Hydraulic AC Control Box	050307	1
3	Screw, #10-24 x 1/2" Socket Button Head Stainless	F05004-196	6
4	Washer, #10 SAE Flat	F05011-18	4
5	Nut, #10-24 Self-Locking Hex	F05010-14	6
6	Latch, Door	051978 ¹	1
7	Switch, Red/Yellow Disconnect 6mm	050883-1 ²	1
8	Decal, Electrical Hazard 2 Places	051948 ³	1
9	Connector, 1/2" Liquid-Tite Straight	E22721	1
10	Connector, 1/2" Liquid-Tite Swivel	051750 ⁴	3
11	Stud, 5/16-18 x 1 1/4" Type CH Clinch	F05006-113	4
12	Plate, LT70 AC Hydraulic Control Insert	050306	1
13	Washer, 5/16" SAE Flat	F05011-17	8
14	Nut, 5/16-18 Self-Locking Hex	F05010-20	8
15	Rail, 35mm x 7.5mm x 6" Steel DIN	024474-6	2

10**Hydraulic System***Hydraulic Control Box (230/460V AC)*

16	Screw, #10-24 x 1/2" Phillips Head	F05004-186	4	
17	Clamp, Plastic DIN Rail	E22707	8	
18	Breaker, 16A 3P Curve D C60N (E25-L)	024904	1	
	Breaker, 8A 3P curve D C60N (E25-H)	050335	1	
19	Contactor, 18A 3P 12VDC Coil	050332	1	
20	Disconnect, 40A 3P Non-Fused 6mm	050903-1 ²	1	
21	Shaft, Disconnect Extension 6mm	050882-1 ²	1	
22	Socket, 11-Pin Relay	E22700	1	
23	Relay, .1-10s 12VDC Coil Timer Off Delay	050314	1	
24	Strap, Timer Relay Retaining	050967	1	
25	Rivet, 1/8" x 1/2" STI SS48D Pop	F04203-5	2	
26	Nut, #8-32 Self-Locking Hex	F05010-41	2	
27	Wire Assembly, 10" Ground	025187	1	

¹ Replaces Latch 050259 originally supplied.

² 5mm Disconnect Shaft OXS5X120 replaced by vendor with 6mm shaft OXS6X120 (2/10). Replacement of any disconnect component requires replacement of disconnect, shaft and operator handle (050903-1, 050883-1 & 050882-1).

³ Decal Added 1/05.

⁴ Swivel Connector 051750 replaces Elbow Fitting E22722 originally supplied.

10.7 Hydraulic Control Box (575V AC)

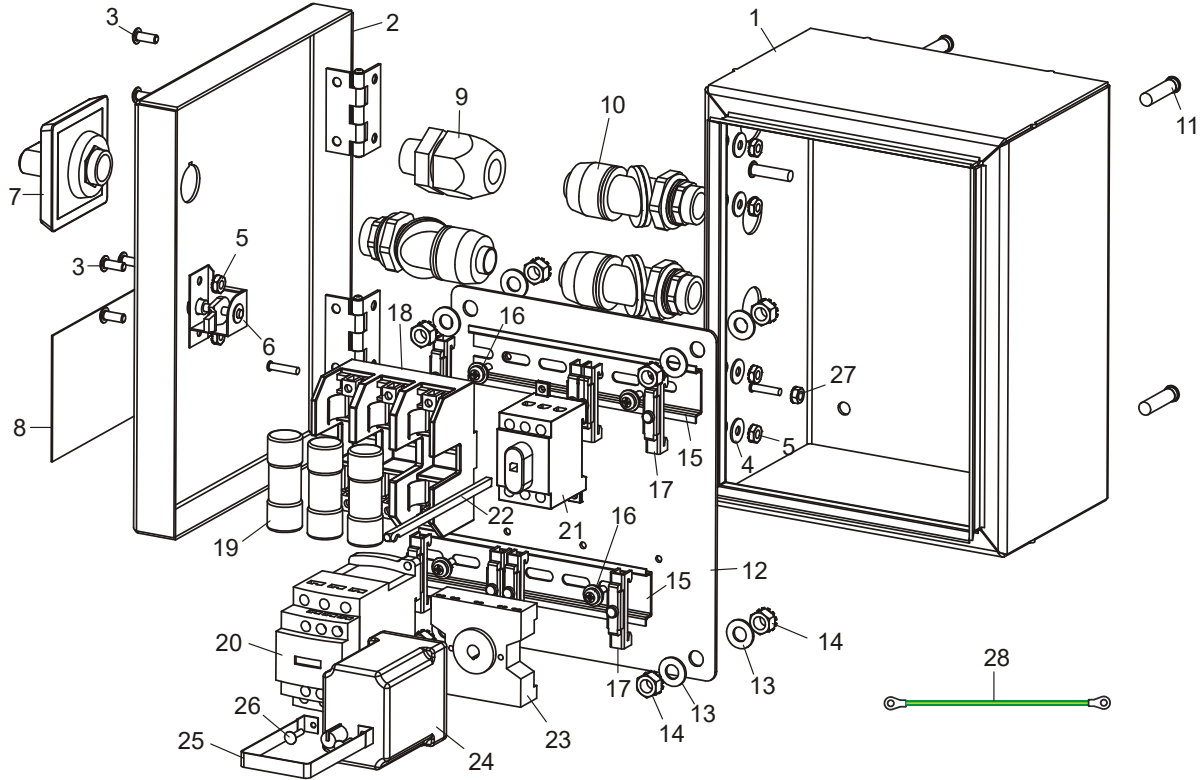

600302

REF	DESCRIPTION (◆ Indicates Parts Available In Assemblies Only)	PART #	QTY.
	CONTROL ASSEMBLY, LT70 E25-C REMOTE HYDRAULIC	050901	1
1	Box Weldment, Hydraulic AC Control	050302	1
2	Door Weldment, Hydraulic AC Control Box	050307	1
3	Screw, #10-24 x 1/2" Socket Button Head Stainless	F05004-196	6
4	Washer, #10 SAE Flat	F05011-18	4
5	Nut, #10-24 Self-Locking Hex	F05010-14	6
6	Latch, Door	051978 ¹	1
7	Switch, Red/Yellow Disconnect 6mm	050883-1 ²	1
8	Decal, Electrical Hazard 2 Places	051948 ³	1
9	Connector, 1/2" Liquid-Tite Straight	E22721	1
10	Connector, 1/2" Liquid-Tite Swivel	051750 ⁴	3
11	Stud, 5/16-18 x 1 1/4" Type CH Clinch	F05006-113	4
12	Plate, LT70 AC Hydraulic Control Insert	050306	1
13	Washer, 5/16" SAE Flat	F05011-17	8
14	Nut, 5/16-18 Self-Locking Hex	F05010-20	8
15	Rail, 35mm x 7.5mm x 6" Steel DIN	024474-6	2
16	Screw, #10-24 x 1/2" Phillips Head	F05004-186	4

10**Hydraulic System***Hydraulic Control Box (575V AC)*

17	Clamp, Plastic DIN Rail	E22707	8	
18	Fuse Block, 30A 600V 3P Class J	050345	1	
19	Fuse, 8A 600V Class J	E22715	3	
20	Contact, 18A 3P 12VDC Coil	050332	1	
21	Disconnect, 40A 3P Non-Fused 6mm	050903-1 ²	1	
22	Shaft, Disconnect Extension 6mm	050882-1 ²	1	
23	Socket, 11-Pin Relay	E22700	1	
24	Relay, .1-10s 12VDC Coil Timer Off Delay	050314	1	
25	Strap, Timer Relay Retaining	050967	1	
26	Rivet, 1/8" x 1/2" STI SS48D Pop	F04203-5	2	
27	Nut, #8-32 Self-Locking Hex	F05010-41	2	
28	Wire Assembly, 10" Ground	025187	1	

¹ Replaces Latch 050259 originally supplied.

² 5mm Disconnect Shaft OXS5X120 replaced by vendor with 6mm shaft OXS6X120 (2/10). Replacement of any disconnect component requires replacement of disconnect, shaft and operator handle (050903-1, 050883-1 & 050882-1).

³ Decal Added 1/05.

⁴ Swivel Connector 051750 replaces Elbow Fitting E22722 originally supplied.

10.8 Hydraulic Valve (DC)

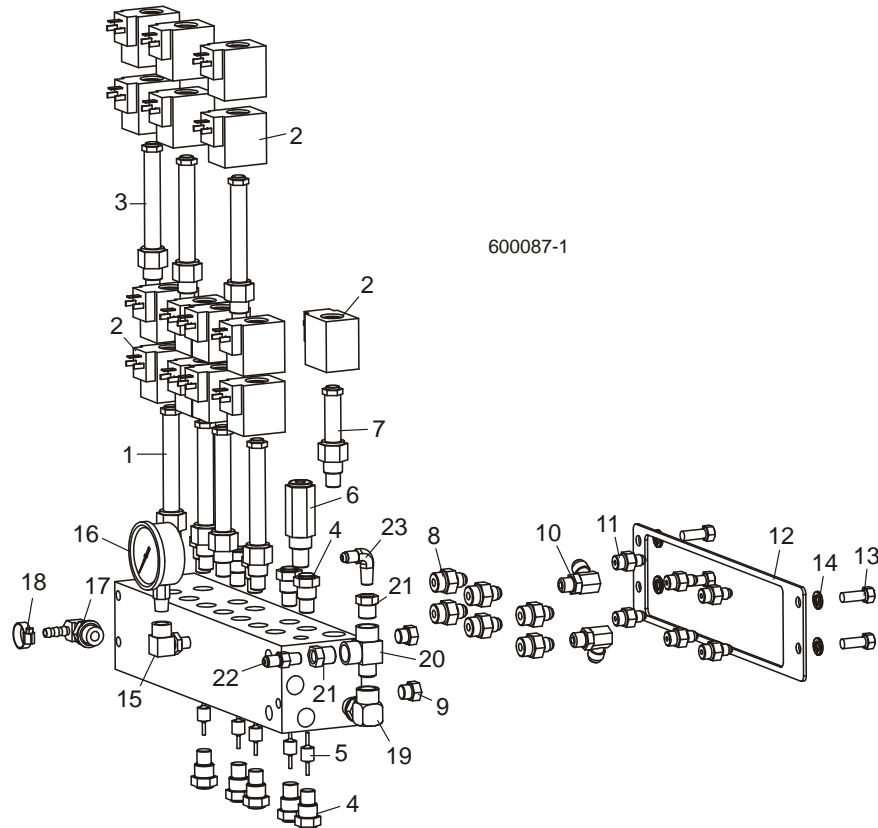

REF	DESCRIPTION (◆ Indicates Parts Available In Assemblies Only)	PART #	QTY.	
	VALVE ASSEMBLY, LT70 REMOTE HYDRAULIC	034640 ¹	1	◆
	Valve Assy, LT70 Remote Hydraulic	034639 ¹	1	◆
1	Valve, 4-Way Sterling #GS04-54-0-0-NC (Loader, Turner, Side Support)	045820	4	
2	Coil, 12V Sterling #CAP-012D	045819	15	
3	Valve, 4-Way Sterling #GS04-52-0-0-NC (Toe Boards, Clamp)	051556	3	
4	Valve, Check Sterling #D020B2-2.IN	051559	10	
5	Piston, Pilot Sterling #PP02DP	051560	5	
6	Valve, Relief Sterling #208-1-B-0-A-C-200	051554	1	
7	Valve, 2-Way Sterling #GS04-26-0-0-NC (Bypass)	051555	1	
8	Fitting, 1/4" JIC x 3/8" O-Ring	P26284	6	
9	Fitting, O-Ring Plug	P12741	2	
10	Fitting, #6 SAE - 3/8" JIC Elbow	P12704	2	
11	Fitting, #8 SAE x #6 JIC	P12703	6	
12	Plate, Hydraulic Valve	034655 ²	1	
13	Bolt, 3/8-16 x 1" Hex Head	F05007-7	4	
14	Washer, 3/8" Split Lock	F05011-4	4	
15	Fitting, 1/4" SAE x 1/4" NPT Elbow	017881	1	

10**Hydraulic System***Hydraulic Valve (DC)*

16	Gauge, 5000 PSI Hydraulic Pressure	P10052	1	
17	Fitting, #8 SAE x 3/8" Hose Barb Elbow	034635	1	
18	Clamp, 11/16" Hose	P12739	1	
19	FITTING, #8 SAE X 3/8" NPT 90° ELBOW	036164 ³	1	
20	FITTING, 3/8" NPT MALE RUN TEE	016822 ³	1	
21	FITTING, 3/8" NPT X 1/4" NPT REDUCER	015490 ³	2	
22	FITTING, 1/4" NPT X 1/4" JIC	P09143 ³	1	
23	FITTING, 1/4" NPT X 1/4" JIC ELBOW	P09142 ³	1	

¹ Valve and Valve Assembly obsolete. 7-Section valve used in production after 4/05. Use kit 036802 to retrofit to new 7-section valve. Use kit 036804 to retrofit valve with additional 8th valve for Log Deck option.

² Plate 034655 for Rev. A1.00 - A2.04 only. Plate welded to box with Rev. A3.00.

³ Fittings replace 015907 originally supplied prior to Rev. A1.07 to improve hose routing.

10.9 Hydraulic Valve (AC)

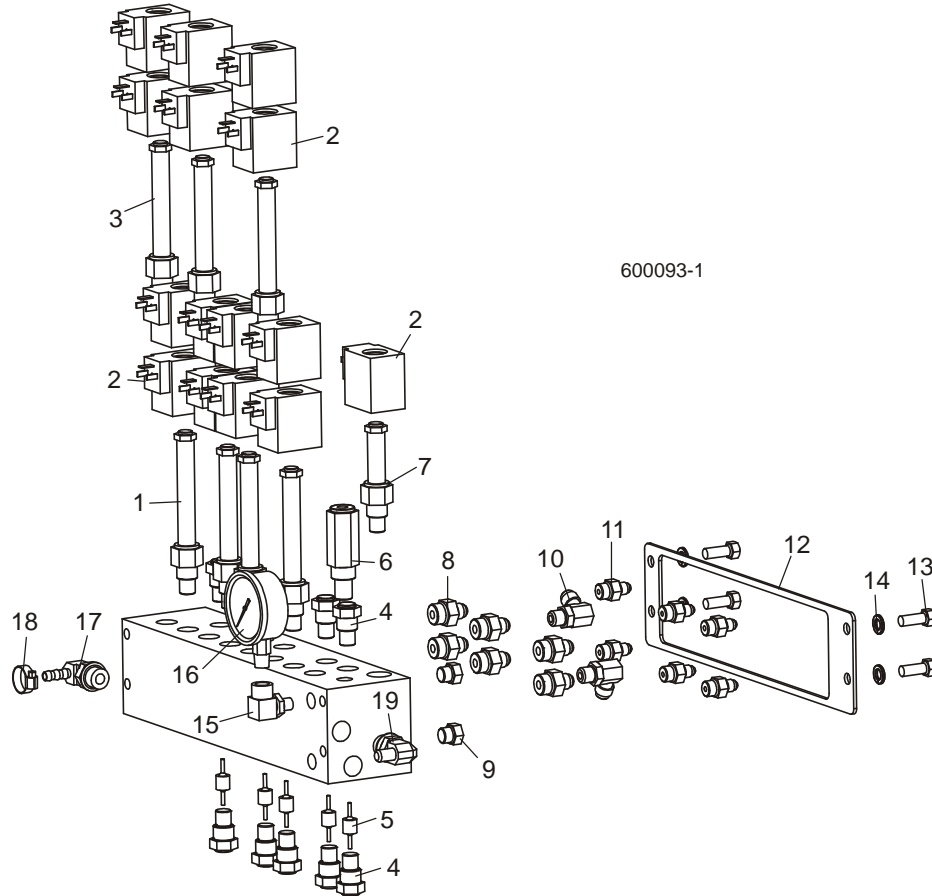

REF	DESCRIPTION (◆ Indicates Parts Available In Assemblies Only)	PART #	QTY.	
	VALVE ASSEMBLY, LT70 REMOTE HYDRAULIC	034640 ¹	1	◆
	Valve Assy, LT70 Remote Hydraulic	034639 ¹	1	◆
1	Valve, 4-Way Sterling #GS04-54-0-0-NC (Loader, Turner, Side Support)	045820	4	
2	Coil, 12V Sterling #CAP-012D	045819	15	
3	Valve, 4-Way Sterling #GS04-52-0-0-NC (Toe Boards, Clamp)	051556	3	
4	Valve, Check Sterling #D020B2-2.IN	051559	10	
5	Piston, Pilot Sterling #PP02DP	051560	5	
6	Valve, Relief Sterling #208-1-B-0-A-C-200	051554	1	
7	Valve, 2-Way Sterling #GS04-26-0-0-NC (Bypass)	051555	1	
8	Fitting, 1/4" JIC x 3/8" O-Ring	P26284	6	
9	Fitting, O-Ring Plug	P12741	2	
10	Fitting, #6 SAE - 3/8" JIC Elbow	P12704	2	
11	Fitting, #8 SAE x #6 JIC	P12703	6	
12	Plate, Hydraulic Valve	034655 ²	1	

10 Hydraulic System

Hydraulic Valve (AC)

13	Bolt, 3/8-16 x 1" Hex Head	F05007-7	4	
14	Washer, 3/8" Split Lock	F05011-4	4	
15	Fitting, 1/4" SAE x 1/4" NPT Elbow	017881	1	
16	Gauge, 5000 PSI Hydraulic Pressure	P10052	1	
17	Fitting, #8 SAE x 3/8" Hose Barb Elbow	034635	1	
18	Clamp, 11/16" Hose	P12739	1	
19	FITTING, #6 JIC - #8 SAE ELBOW	015907 ³	1	

¹ Valve and Valve Assembly obsolete. 7-Section valve used in production after 4/05. Use kit 036802 to retrofit to new 7-section valve. Use kit 036804 to retrofit valve with additional 8th valve for Log Deck option.

² Plate 034655 for Rev. A1.00 - A2.04 only. Plate welded to box with Rev. A3.00.

³ Fitting 015907 removed from valve assembly 034640 (Rev. A1.07).

10.10 Hydraulic Power Supply Strip (DC Only)

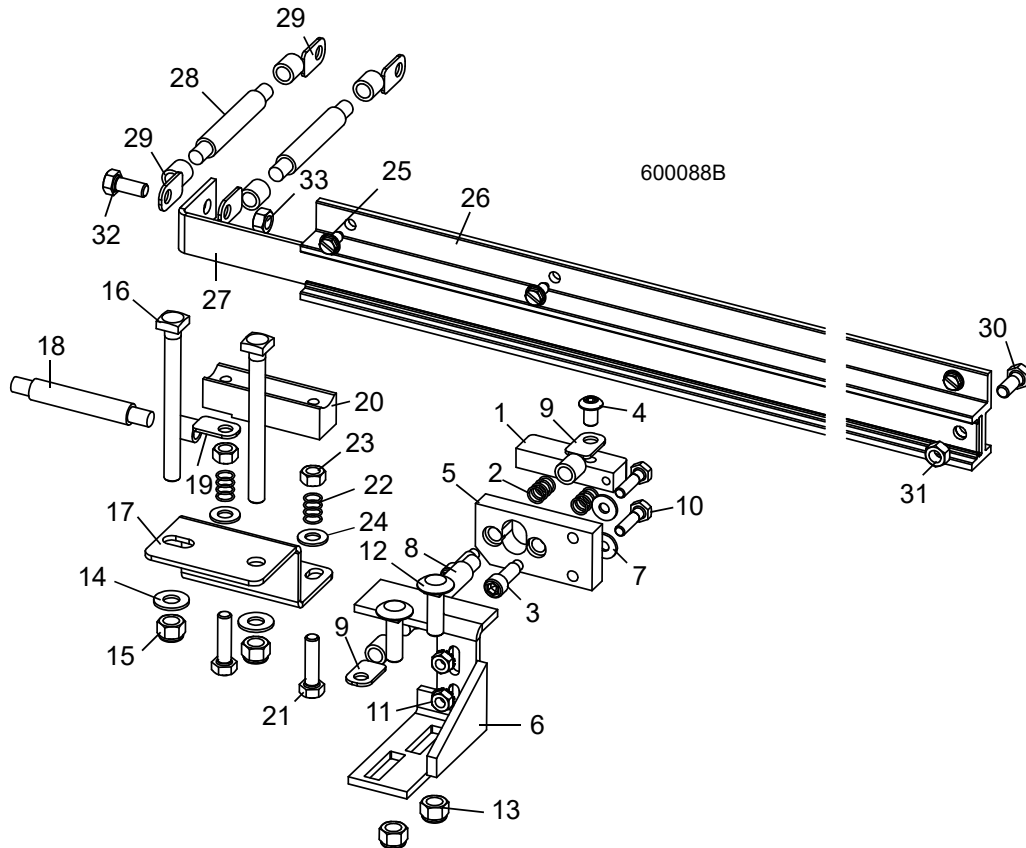

REF	DESCRIPTION (◆ Indicates Parts Available In Assemblies Only)	PART #	QTY.	
	CONTACT ASSEMBLY, HYDRAULIC POWER SUPPLY (POSITIVE)	010103	1	
	Contact Kit, Hydraulic Power Supply Positive	007716	1	
1	Contact, Hydraulic Power Supply (Positive)	015253	1	
2	Spring, Positive Contact	P10077	2	
3	Bolt, 5/16" X 3/4" Shoulder (1/4-20 Thread) Stainless	F05006-143 ¹	2	
4	Bolt, 5/16-18 x 1/2" Socket Button Head	F05006-20	1	
5	Insulator, Positive Contact	S10072	1	
6	Bracket, Positive Contact Mounting	015324	1	
7	Washer, 1/4" SAE Flat	F05011-11	2	
8	Cable, 1AWG SO Welding	R01971 ²	1.17	
9	Terminal, 5/16" 1-2GA Ring NI Loose	F05092-16 ²	2	
10	Bolt, 1/4-20 X 1" Hex Head Grade 2	F05005-38	2	
11	Nut, 1/4-20 Hex Self-Locking	F05010-9	2	
12	Bolt, 3/8-16 X 1 1/4" Carriage Head	F05007-11	2	
13	Nut, 3/8-16 Hex Nylon Lock	F05010-10	2	

10

Hydraulic System

Hydraulic Power Supply Strip (DC Only)

	CONTACT KIT, HYDRAULIC POWER SUPPLY (GROUND)	017948	1	
14	Washer, 3/8" SAE Flat	F05011-3	2	
15	Nut, 3/8-16 Hex Nylon Lock	F05010-10	2	
16	Bolt, 3/8-16 X 4" Square Head	F05007-175	2	
17	Bracket, Ground Contact Mounting	017949	1	
	Cable Assy, Hydraulic Negative Contact (Ground) #1 Weld	036306	1	
18	Cable, #1 Weld	R01971	2.17 Ft	◆
19	Terminal, 5/16" Ring #2 Gauge	F05092-16	2	
	Contact Kit, Hydraulic Power Supply Ground	007717	1	
20	Contact, Hydraulic Power Supply (Ground)	015264 ³	1	◆
21	Bolt, 5/16-18 X 1 1/4" Hex Head Full Thread Grade 5	F05006-93	2	
22	Spring, Ground Contact	P10077	2	
23	Nut, 5/16-18 Hex	F05010-17	2	
24	Washer, 5/16" SAE Flat	F05011-17	2	
	STRIP ASSEMBLY, LT70HD REMOTE DC	017860	1	
25	Screw, 1/4-20 X 1/2" Slotted Hex Head	F05015-1	8	
26	Housing, LT70HD Remote DC Contact Strip	017858	1	
	Strip, LT70HD Remote DC Contact w/Cables	N/A	1	
27	Strip, LT70HD Remote DC Contact	017859	1	
28	Cable, #1 Weld	R01971	11.67 Ft	◆
29	Terminal, 5/16" Ring #2 Gauge	F05092-16	4	
30	Bolt, 5/16-18 X 3/4" Hex Head Black Nylon	F05006-45	1	
31	Nut, 5/16-18 Hex Black Nylon	F05010-86	1	
32	Tube, 5/8" Heat Shrink	R01950-5	.33 Ft	◆
33	Bolt, 5/16-18 x 3/4" Hex Head	F05006-5	1	
34	Nut, 5/16-18 Hex	F05010-17	1	

¹ Stainless Steel Bolt F05006-143 replaces F05006-44 to prevent corrosion (12/09).

² See Section 5.10 for pre-assembled cable service assemblies.

³ 015264 not available for service. Use kit 007717.

10.11 Hydraulic Power Supply Strip (AC Only)

Rev. A1.00 - A1.05 ¹

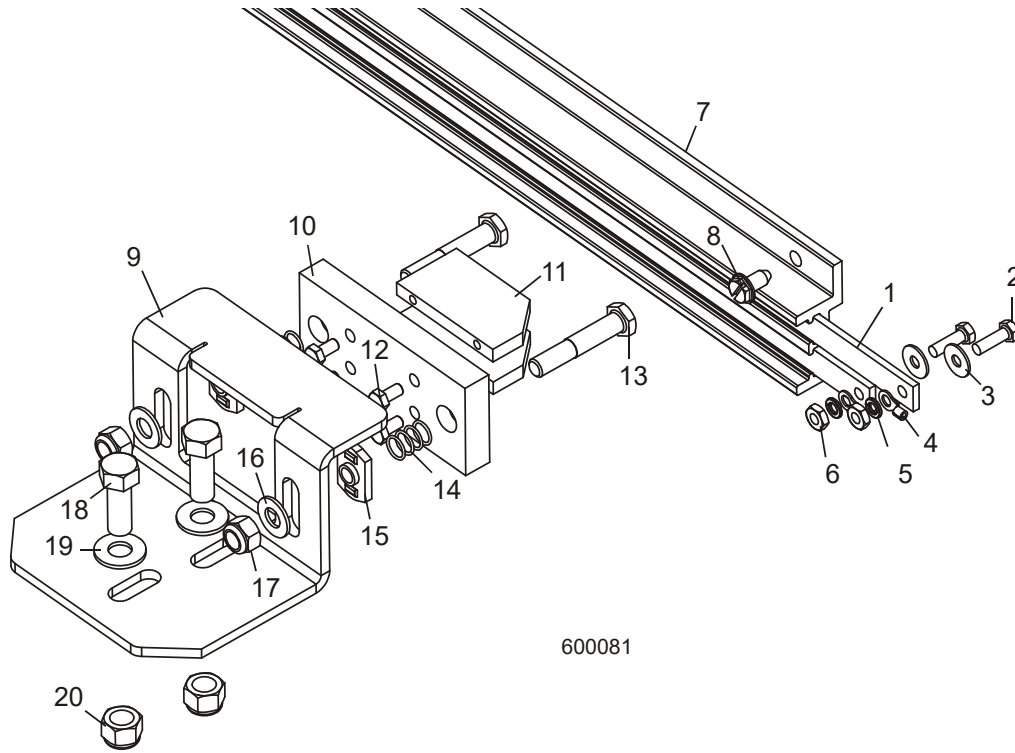

600081

REF	DESCRIPTION (◆ Indicates Parts Available In Assemblies Only)	PART #	QTY.
	STRIP ASSEMBLY, HYDRAULIC POWER SUPPLY (AC)	034867 ¹	1
1	Strip, AC Hydraulic Power Supply	034866	2
2	Bolt, #10-32 x 5/8" Hex Head	F05004-152	2
3	Washer, #10 Brass	042867 ²	2
4	Terminal, #10 14-16 Gauge Ring NI Loose	F05092-9	2
5	Washer, #10 Split Lock	F05011-20	1
6	Nut, #10-32 Hex	F05010-27	2
7	Housing, AC Hydraulic Power Supply	044015	1
8	Bolt, 1/4-20 x 1/2" Self-Tapping Hex Head	F05015-1	8
	CONTACT, HYDRAULIC POWER SUPPLY (AC)	034880 ¹	1
9	Bracket, Contact Mounting	034879	1
10	Block, AC Contact Insulating	034874	1
11	Block, AC Contact	034869	2
12	Bolt, #10-32 x 1/2" Hex Head	F05004-60	4
13	Bolt, 5/16-18 x 1 3/4" Hex Head	F05009-70 ³	2

¹ Contact strip assembly removed for AC Remotes Rev. A1.06. Hydraulics are now operational with key switch on unless feed is in forward motion.

10**Hydraulic System***Hydraulic Power Supply Strip (AC Only)*

14	Spring, .42" x .59" x .042" Compression	P10077	2	
15	Nut, 5/16-18 Stainless Steel Weld	F05010-179	2	
16	Washer, 5/16" SAE Flat	F05011-17	2	
17	Nut, 5/16-18 Hex Nylon Lock	F05010-58	2	
18	Bolt, 3/8-16 x 1" Hex Head	F05007-7	2	
19	Washer, 3/8" SAE Flat	F05011-3	2	
20	Nut, 3/8-16 Hex Nylon Lock	F05010-10	2	

¹ AC Contact Strip Assembly 034867 replaces 044014 and Contact Assembly 034880 replaces 044008 (Rev. A1.02).

² 042867 replaces #10 SAE Flat Washer F05011-18 (1/03).

³ F05009-70 replaces 034888 (9/02).

10.12 Hydraulic Log Loader

LT70HD Remote

Rev. A2.03+

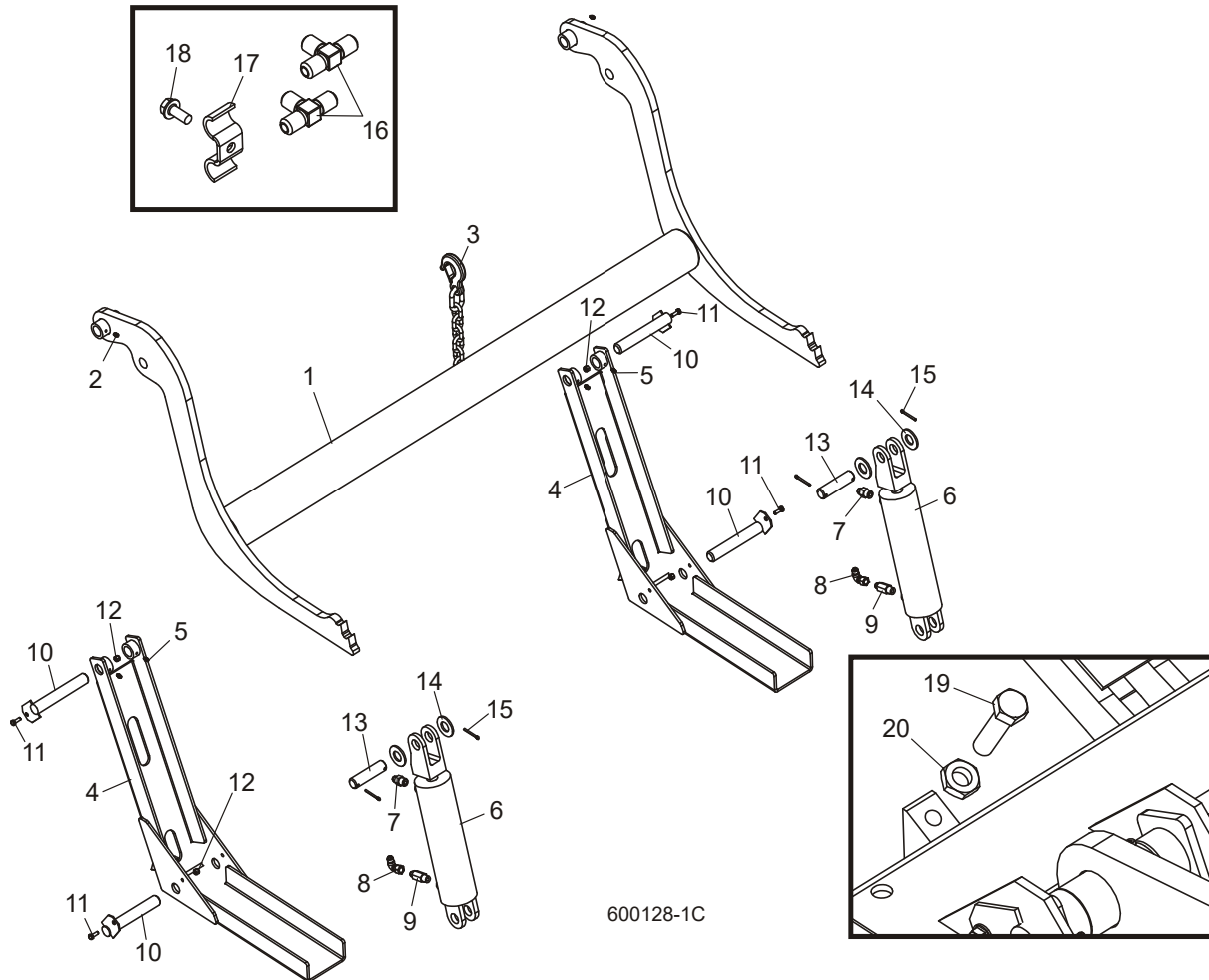

REF	DESCRIPTION (◆ Indicates Parts Available In Assemblies Only)	PART #	QTY.
	LOADER ASSEMBLY, HYDRAULIC LOG (LT60HD/70HD)	034539 ¹	1
1	Arm, Hydraulic Log Loading	W11805	1
2	Fitting, 3/16" Grease	P04107	2
3	Chain, Hydraulic Log Loader Safety	A04376	1
4	Channel, Hydraulic Log Loading Foot	W09444	2
5	Fitting, 3/16" Grease	P04107	4
	Cylinder Assembly, Hydraulic Log Loader	017645 ¹	2
6	Cylinder, 8" X 3" Hydraulic (3/8" NPT Ports)	042754 ¹	1
	Seal Kit, 8" x 3" Hydraulic Cylinder	P12956	1
7	Fitting, 3/8" NPT x 3/8" JIC Male Connector	016819 ¹	1
8	Fitting, 3/8" JIC 90° Swivel Elbow	042756 ¹	1

10

Hydraulic System Hydraulic Log Loader

9	Fitting, 3/8NPT 6.0GPM Velocity Fuse	042755 ¹	1	
10	Pin, Loading Arm Mount	W09446	4	
11	Bolt, 1/4-20 x 3/4" Hex Head Full Thread	F05005-1	4	
12	Nut, 1/4-20 Hex Lock	F05010-69	4	
13	Pin, Loading Arm Cylinder Mount	S09251	2	
14	Washer, 1" SAE Flat	F05011-28	4	
15	Pin, 3/16" X 1 1/2" Cotter	F05012-23	4	
16	Fitting, 3/8" JIC Union 'T'	015487	1	
17	Clamp, 3/8" Hydraulic Hose	016041	6	
18	Bolt, 5/16-18 X 3/4" Hex Head Grade 5	F05006-102 ²	6	
19	BOLT, 1/2-13 X 3" HEX HEAD FULL THREAD GRADE 5	F05008-7	2	
20	NUT, 1/2-13 JAM	F05010-31	2	

¹ Loader Arm Assembly 034539 updated with hydraulic cylinders with 3/8" NPT ports and 3/8" fittings. Cylinder Assembly 017645 replaces 015562 to accommodate 6 GPM velocity fuses (Rev. A2.03). 6 GPM velocity fuses match the flow of the LT60/70 hydraulic system and reduce the possibility of the loading arms locking up in the downward direction.

² Grade 5 Hex Head Bolt F05006-102 replaces self-tapping bolt F05006-30 to eliminate shearing of bolts head (4/08).

10.13 Hydraulic Log Loader

LT70HD Remote

Rev. A1.00 - A2.02

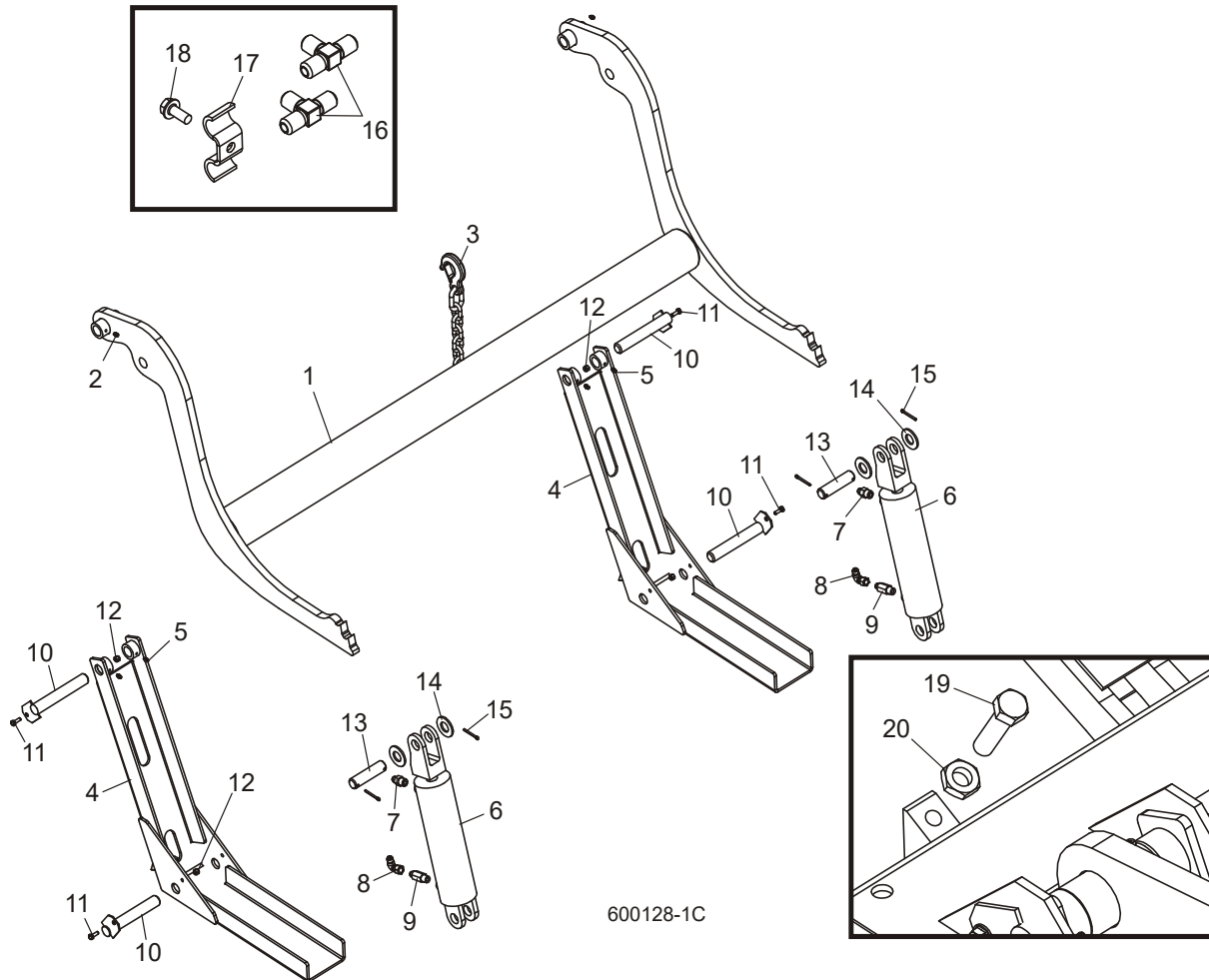

600128-1C

REF	DESCRIPTION (◆ Indicates Parts Available In Assemblies Only)	PART #	QTY.	
	LOADER ASSEMBLY, HYDRAULIC LOG (LT60HD/70HD)	034539 ¹	1	
1	Arm, Hydraulic Log Loading	W11805	1	
2	Fitting, 3/16" Grease	P04107	2	
3	Chain, Hydraulic Log Loader Safety	A04376	1	
4	Channel, Hydraulic Log Loading Foot	W09444	2	
5	Fitting, 3/16" Grease	P04107	4	
	Cylinder Assembly, Super Hydraulic Log Loading Arm	015562 ²	2	◆
6	Cylinder, 8" X 3" Hydraulic	P12847	1	
	Seal Kit, 8" x 3" Hydraulic Cylinder	P12956	1	
7	Fitting, 1/4 NPT - 3/8" JIC Straight	015560	2	
8	Fitting, 0455x4x4 90° Swivel Elbow	P12199	1	

10

Hydraulic System Hydraulic Log Loader

	Fitting Kit, 1/4NPT 5.0GPM Velocity Fuse	015832	1	
9	Fitting, 1/4NPT 5.0GPM Velocity Fuse	015750	2	◆
	Instruction Sheet, Velocity Fuse Replacement	015832-255	1	
10	Pin, Loading Arm Mount	W09446	4	
11	Bolt, 1/4-20 x 3/4" Hex Head Full Thread	F05005-1	4	
12	Nut, 1/4-20 Hex Lock	F05010-69	4	
13	Pin, Loading Arm Cylinder Mount	S09251	2	
14	Washer, 1" SAE Flat	F05011-28	4	
15	Pin, 3/16" X 1 1/2" Cotter	F05012-23	4	
16	Fitting, 3/8" JIC Union 'T'	015487	1	
17	Clamp, 3/8" Hydraulic Hose	016041	6	
18	Bolt, 5/16-18 X 3/4" Hex Head Grade 5	F05006-102 ³	6	
19	BOLT, 1/2-13 X 3" HEX HEAD FULL THREAD GRADE 5	F05008-7	2	
20	NUT, 1/2-13 JAM	F05010-31	2	

¹ Loader Arm Assembly 034539 updated with hydraulic cylinders with 3/8" NPT ports and 3/8" fittings to accommodate 6 GPM velocity fuses ([See Section 10.12](#)).

² Cylinder assembly no longer available for service. Sell cylinder w/o fittings P12847 to insure compatibility of velocity fuses.

³ Grade 5 Hex Head Bolt F05006-102 replaces self-tapping bolt F05006-30 to eliminate shearing of bolts head (4/08).

10.14 Hydraulic Log Turner

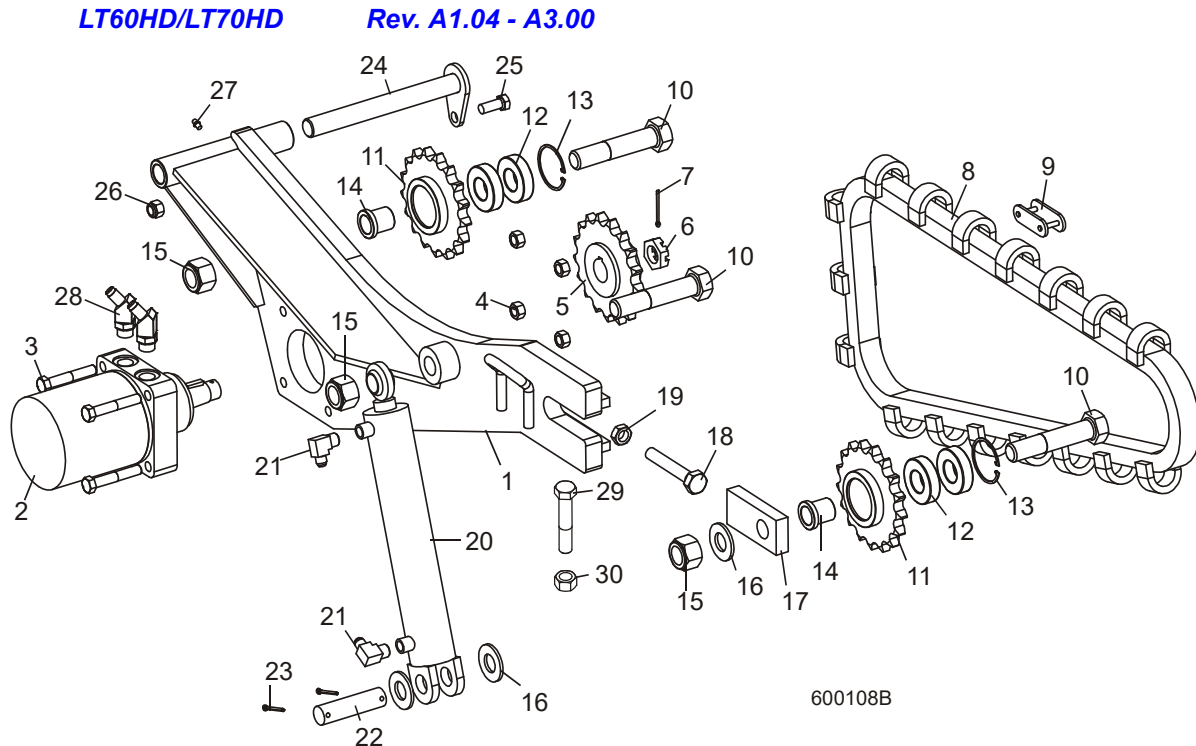

REF	DESCRIPTION (◆ Indicates Parts Available In Assemblies Only)	PART #	QTY.
	ARM ASSEMBLY, HYDRAULIC LOG TURNER	034537	1
1	Arm Weldment, Hydraulic Log Turner	016873	1
2	Motor, Hydraulic Log Turner	007331 ¹	1
3	Bolt, 1/2-13 x 3" Hex Head Grade 5	F05008-23	4
4	Nut, 1/2-13 Hex Lock	F05010-3	4
5	Sprocket Weldment, Log Turner Drive	042192	1
6	Nut, Hydraulic Motor Castle	018741-2	1
7	Pin, 1/8" x 1 3/4" Cotter	F05012-43	1
8	Chain Weldment, Log Turner	025655 ²	1
	Cog, Log Turner	042194 ³	17
	Chain, #2080 Log Turner	042195	1
9	Link, #2080H Master	016796	1
10	Bolt, 1-8 x 5" Hex Head Grade 8	F05004-132	3
	Sprocket Assembly, Idler	042193	2
11	Sprocket Weldment, Idler	042191	1
12	Bearing, 6206 25 Idler	P11035	2
13	Ring, 62mm #472 DIN Inside Retaining	F04254-12	1
14	Spacer, Idler Sprocket	042187	2
15	Nut, 1-8 Hex Lock	F05010-109	3

10

Hydraulic System Hydraulic Log Turner

16	Washer, 1" SAE Flat	F05011-28	3	
17	Plate, Log Turner Chain Tensioner	042188	1	
18	Bolt, 5/8-11 x 4" Hex Head Full Thread Grade 5	F05009-31	1	
19	Nut, 5/8-11 Hex Jam	F05010-82	1	
20	Cylinder, 2" x 10" Welded Rod End Hydraulic	034267	1	
	Seal Kit, 2x10 Hydraulic Cylinder	003814	1	
21	Fitting, 3/8" NPT x 3/8" JIC 90° Elbow	016820	2	
22	Pin, 1" x 3.88"	S09251	1	
23	Pin, 3/16" x 1 1/2" Cotter	F05012-23	2	
24	Pin Weldment, Log Turner Mount	042331	1	
25	Bolt, 1/2-13 x 1 1/4" Hex Head Grade 5	F05008-37	1	
26	Nut, 1/2-13 Hex Nylon Lock	F05010-8	1	
27	Fitting, 1/4-28 Grease	P05060	1	
28	FITTING, #10 SAE X 3/8" JIC 45° ELBOW	034538 ⁴	2	
29	BOLT, 5/8-18 X 3 1/2" HEX HEAD BOLT FULL THREAD	F05009-16	1	
30	NUT, 5/8-18 HEX	F05010-50	1	

¹ Hydraulic Motor 007331 replaces 018741 originally supplied prior to 6/09. 018741 was changed by the vendor and no longer fits the hole in the log turner arm.

² Turner Chain 025655 replaces original chain 042196 supplied prior to 4/10. New chain provides more aggressive log turning.

³ Applies to original Turner Chain 042196 only.

⁴ Fittings removed from turner assembly Rev. A2.04.

10.15 Hydraulic Log Turner

LT60HD/LT70HD Rev. A1.00 - A1.03

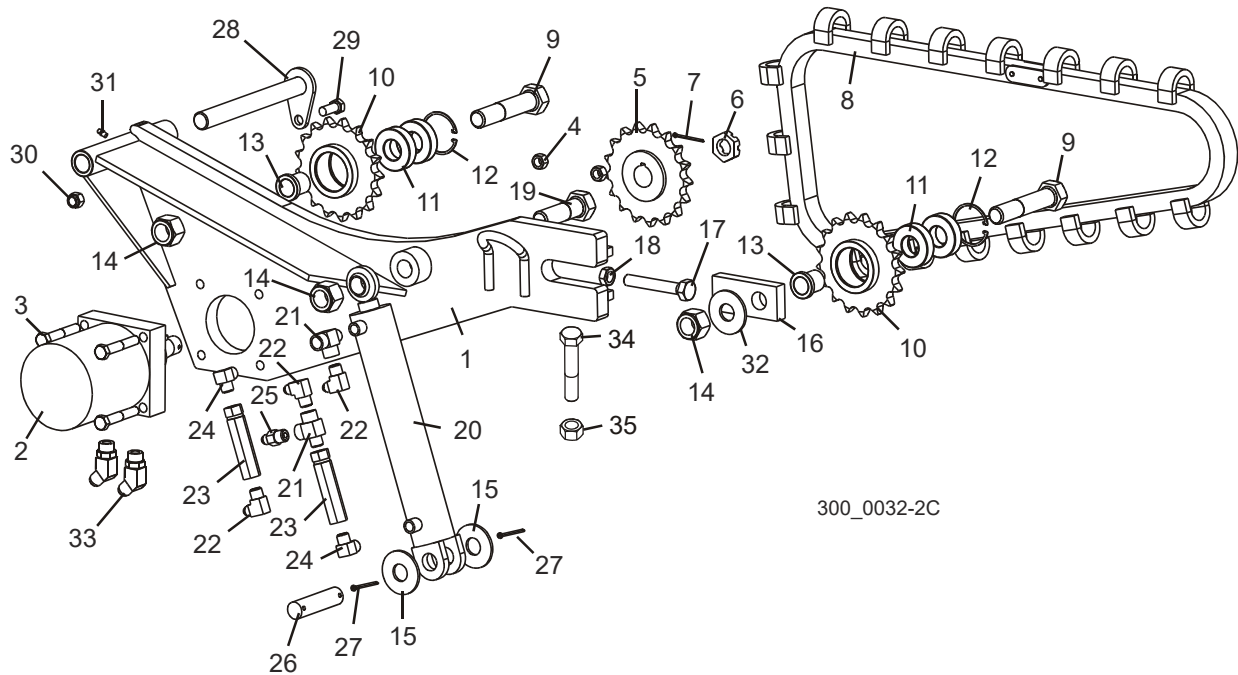

REF	DESCRIPTION (◆ Indicates Parts Available In Assemblies Only)	PART #	QTY.
	ARM ASSEMBLY, HYDRAULIC LOG TURNER	034537 ¹	1
1	Arm Weldment, Hydraulic Log Turner	016873	1
2	Motor, Hydraulic Log Turner	007331 ²	1
3	Bolt, 1/2-13 x 3" Hex Head Grade 5	F05008-23	4
4	Nut, 1/2-13 Hex Lock	F05010-3	4
5	Sprocket Weldment, Log Turner Drive	042192	1
6	Nut, Hydraulic Motor Castle	018741-2	1
7	Pin, 1/8" x 1 3/4" Cotter	F05012-43	1
8	Chain Weldment, Log Turner	025655 ³	1
	Cog, Log Turner	042194 ⁴	17
	Chain, #2080 Log Turner	042195	1
	Link, #2080H Master	016796	1
9	Bolt, 1-8 x 5" Hex Head Grade 8	F05004-132	2
	Sprocket Assembly, Idler	042193	2
10	Sprocket Weldment, Idler	042191	1
11	Bearing, 6206 25 Idler	P11035	2
12	Ring, 62mm #472 DIN Inside Retaining	F04254-12	1
13	Spacer, Idler Sprocket	042187	2
14	Nut, 1-8 Hex Lock	F05010-109	3

10

Hydraulic System Hydraulic Log Turner

15	Washer, 1" SAE Flat	F05011-28	2	
16	Plate, Log Turner Chain Tensioner	042188	1	
17	Bolt, 5/8-11 x 4" Hex Head Full Thread Grade 5	F05009-31	1	
18	Nut, 5/8-11 Hex Jam	F05010-82	1	
19	Bolt, 1-8 x 3 1/2" Hex Head Grade 5	F05009-50	1	
20	Cylinder, 2" x 10" Welded Rod End Hydraulic	034267	1	
	Seal Kit, 2x10 Hydraulic Cylinder	003814	1	
21	Fitting, 3/8" NPT Male Run T	016822	2	
22	Fitting, 3/8" NPT x 3/8" JIC 90° Elbow	016820	3	
23	Valve, 1000 PSI Sequence	042724 ¹	2	
24	Fitting, 3/8" NPT 90° Elbow	016821	2	
25	Fitting, 3/8" NPT x 3/8" JIC Male Connector	016819	1	
26	Pin, 1" x 3.88"	S09251	1	
27	Pin, 3/16" x 1 1/2" Cotter	F05012-23	2	
28	Pin Weldment, Log Turner Mount	042331	1	
29	Bolt, 1/2-13 x 1 1/4" Hex Head Grade 5	F05008-37	1	
30	Nut, 1/2-13 Hex Nylon Lock	F05010-8	1	
31	Fitting, 1/4-28 Grease	P05060	1	
32	Washer, 1" ID x 2" OD x 1/4" Thick	038749 ⁵	1	
33	FITTING, #10 SAE X 3/8" JIC 45° ELBOW	034538 ⁶	2	
34	BOLT, 5/8-18 X 3 1/2" HEX HEAD BOLT FULL THREAD	F05009-16	1	
35	NUT, 5/8-18 HEX	F05010-50	1	

¹ Turner assembly revised Rev. A1.04. Sequence valves moved to side support cylinder and hydraulic motor rotated 90° ([See Section 10.14](#)).

² Hydraulic Motor 007331 replaces 018741 originally supplied prior to 6/09. 018741 was changed by the vendor and no longer fits the hole in the log turner arm. MB29 Hydraulic Motor 018741 replaced MB15-02-08 Hydraulic Motor 018181 supplied prior to Rev. A1.02.

³ Turner Chain 025655 replaces original chain 042196 supplied prior to 4/10. New chain provides more aggressive log turning.

⁴ Applies to original Turner Chain 042196 only.

⁵ Thicker Washer 038749 replaces 1" SAE Washer F05011-28 to prevent washer from pulling into slot when assembly is tightened (5/06).

⁶ Fittings removed from turner assembly 9/03.

10.16 Hydraulic Log Side Supports (Front)

LT60HD/LT70HD Rev. A1.04 - A3.00

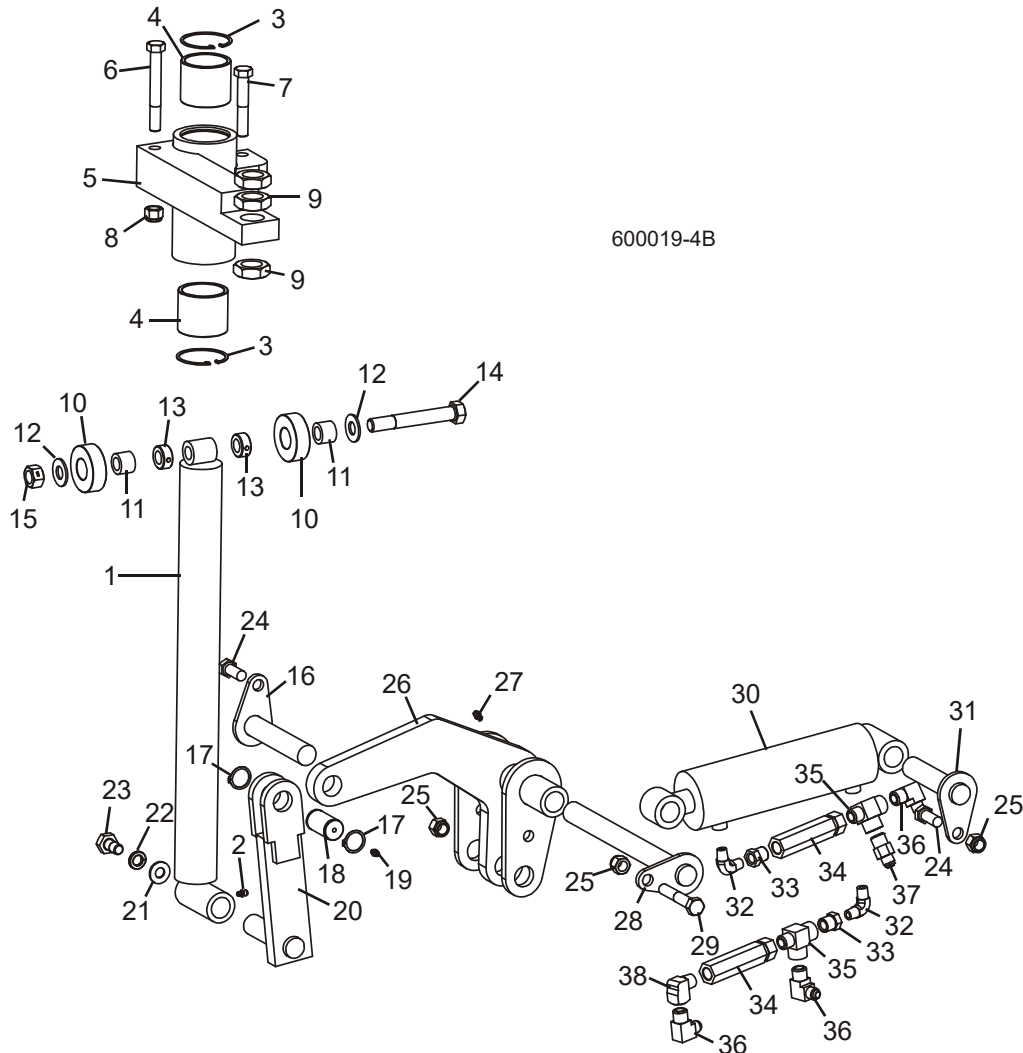

REF	DESCRIPTION (◆ Indicates Parts Available In Assemblies Only)	PART #	QTY.
	SUPPORT ASSEMBLY, VERTICAL HYDRAULIC SIDE	034732	1
1	Rod Weldment, Vertical Side Support	034704	1
2	Fitting, 3/16" Straight Grease	P04107	1
3	Ring, 62mm Din #472 Inside Retaining	F04254-12	2
4	Bushing, Side Support	042262	2
5	Mount Weldment, Vertical Side Support	034703	1
6	Bolt, 1/2-13 x 4" Hex Head Grade 5	F05008-78	1
7	Bolt, 1/2-13 x 3" Hex Head Grade 5	F05008-23	1
8	Nut, 1/2-13 Hex Nylon Lock	F05010-8	2
9	Nut, 1-14 Hex Jam	F05010-118	3

10

Hydraulic System

Hydraulic Log Side Supports (Front)

	Roller Kit, Side Support	034733	1	
10	Roller, Side Support	016561	2	
11	Bushing, 5/8" x 1" x 3/4" Bronze	016560	2	
12	Washer, 5/8" SAE Flat	F05011-5	2	
13	Collar, 5/8" Lock	P05035	2	
14	Bolt, 5/8-11 x 4 1/2" Hex Head Grade 5	F05009-10	1	
15	Nut, 5/8-11 Hex Lock	F05010-4	1	
16	PIN WELDMENT, 5 1/4" PIVOT	034727	1	
	PIN ASSEMBLY, SIDE SUPPORT PIVOT	036053	1	
17	Pin, Grooved Pivot	034718	1	◆
18	Ring, 1" 3100-100 Outside Retaining	F04254-15	2	
19	Fitting, 3/16" Straight Grease	P04107	1	
20	PUSHER WELDMENT, LOWER SIDE SUPPORT	034711	1	
21	WASHER, 9/16" SAE FLAT	F05011-52 ¹	1	
22	WASHER, 1/2" SPLIT LOCK	F05011-9	1	
23	BOLT, 1/2-13 X 1" HEX HEAD	F05008-50	1	
24	BOLT, 1/2"-13 X 1 1/4" HEX HEAD GRADE 5	F05008-37	2	
25	NUT, 1/2-13 HEX NYLON LOCK	F05010-8	3	
26	ARM WELDMENT, VERTICAL SIDE SUPPORT FRONT LIFT	034715	1	
27	FITTING, 3/16" STRAIGHT GREASE	P04107	1	
28	PIN WELDMENT, 10 7/8" PIVOT	034728	1	
29	BOLT, 1/2-13 X 3" HEX HEAD GRADE 5	F05008-23	1	
30	CYLINDER, 2 1/2" X 6" X 1/4" NPT PORT HYDRAULIC	034736	1	
31	PIN WELDMENT, 4 3/8" PIVOT	034726	1	
32	FITTING, 1/4" NPT MALE PIPE ELBOW	P09140	2	
33	FITTING, 3/8" NPT X 1/4" NPT REDUCER	015490	2	
34	VALVE, SIDE SUPPORT SEQUENCE	015484	2	
35	FITTING, 3/8" NPT MALE RUN TEE	016822	2	
36	FITTING, 3/8" NPT X 3/8" JIC ELBOW	016820	3	
37	FITTING, 3/8" NPT X 3/8" JIC CONNECTOR	016819	1	
38	FITTING, 3/8" NPT STREET ELBOW	P05759	1	

¹ Replaces F05011-2 1/2" SAE Flat Washer originally supplied prior to Rev. A2.00. Increased outside diameter improves retainment of pusher weldment.

10.17 Hydraulic Log Side Supports (Front)

LT60HD/LT70HD Rev. A1.00 - A1.03

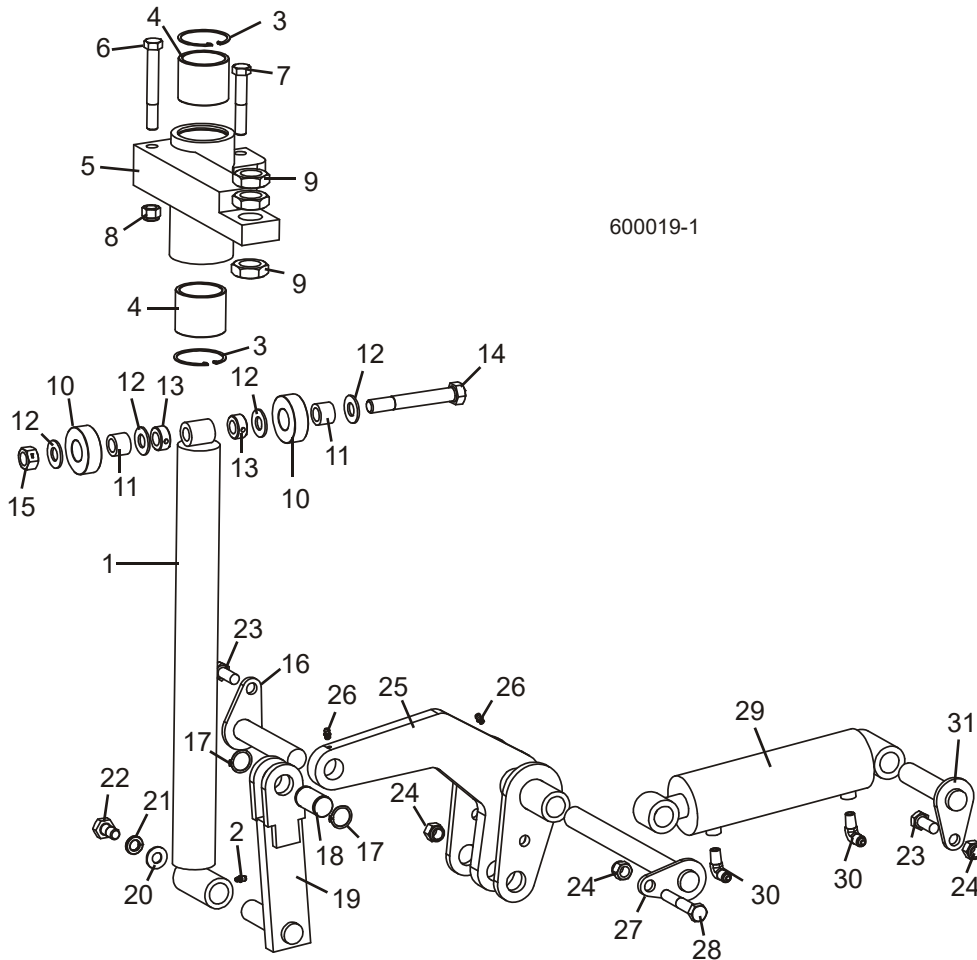

REF	DESCRIPTION (◆ Indicates Parts Available In Assemblies Only)	PART #	QTY.
	SUPPORT ASSEMBLY, VERTICAL HYDRAULIC SIDE	034732	1
1	Rod Weldment, Vertical Side Support	034704	1
2	Fitting, 3/16" Straight Grease	P04107	1
3	Ring, 62mm Din #472 Inside Retaining	F04254-12	2
4	Bushing, Side Support	042262	2
5	Mount Weldment, Vertical Side Support	034703	1
6	Bolt, 1/2-13 x 4" Hex Head Grade 5	F05008-78	1
7	Bolt, 1/2-13 x 3" Hex Head Grade 5	F05008-23	1
8	Nut, 1/2-13 Hex Nylon Lock	F05010-8	2
9	Nut, 1-14 Hex Jam	F05010-118	3
	Roller Kit, Side Support	034733	1
10	Roller, Side Support	016561	2
11	Bushing, 5/8" x 1" x 3/4" Bronze	016560	2

10

Hydraulic System

Hydraulic Log Side Supports (Front)

12	Washer, 5/8" SAE Flat	F05011-5	2	
13	Collar, 5/8" Lock	P05035	2	
14	Bolt, 5/8-11 x 4 1/2" Hex Head Grade 5	F05009-10	1	
15	Nut, 5/8-11 Hex Lock	F05010-4	1	
16	PIN WELDMENT, 5 1/4" PIVOT	034727	1	
17	PIN, GROOVED PIVOT	034718 ¹	1	◆
18	RING, 1" 3100-100 OUTSIDE RETAINING	F04254-15	2	
19	PUSHER WELDMENT, LOWER SIDE SUPPORT	034711	1	
20	WASHER, 1/2" SAE FLAT	F05011-2	1	
21	WASHER, 1/2" SPLIT LOCK	F05011-9	1	
22	BOLT, 1/2-13 X 1" HEX HEAD	F05008-50	1	
23	BOLT, 1/2"-13 X 1 1/4" HEX HEAD GRADE 5	F05008-37	2	
24	NUT, 1/2-13 HEX NYLON LOCK	F05010-8	3	
25	ARM WELDMENT, VERTICAL SIDE SUPPORT FRONT LIFT	034715	1	
26	FITTING, 3/16" STRAIGHT GREASE	P04107	2	
27	PIN WELDMENT, 10 7/8" PIVOT	034728	1	
28	BOLT, 1/2-13 X 3" HEX HEAD GRADE 5	F05008-23	1	
29	CYLINDER, 2 1/2" X 6" X 1/4" NPT PORT HYDRAULIC	034736	1	
30	FITTING, 3/8" JIC X 1/4" NPT ELBOW	015491 ²	2	
31	PIN WELDMENT, 4 3/8" PIVOT	034726	1	

¹ Use Pin Assembly 036053 to replace Pin 034718. Pin modified to accept grease fitting ([See Section 10.16](#)).

² Fittings replaced with sequence valves and fittings previously supplied on log turner cylinder (Rev. A1.04).

10.18 Hydraulic Log Side Supports (Rear)

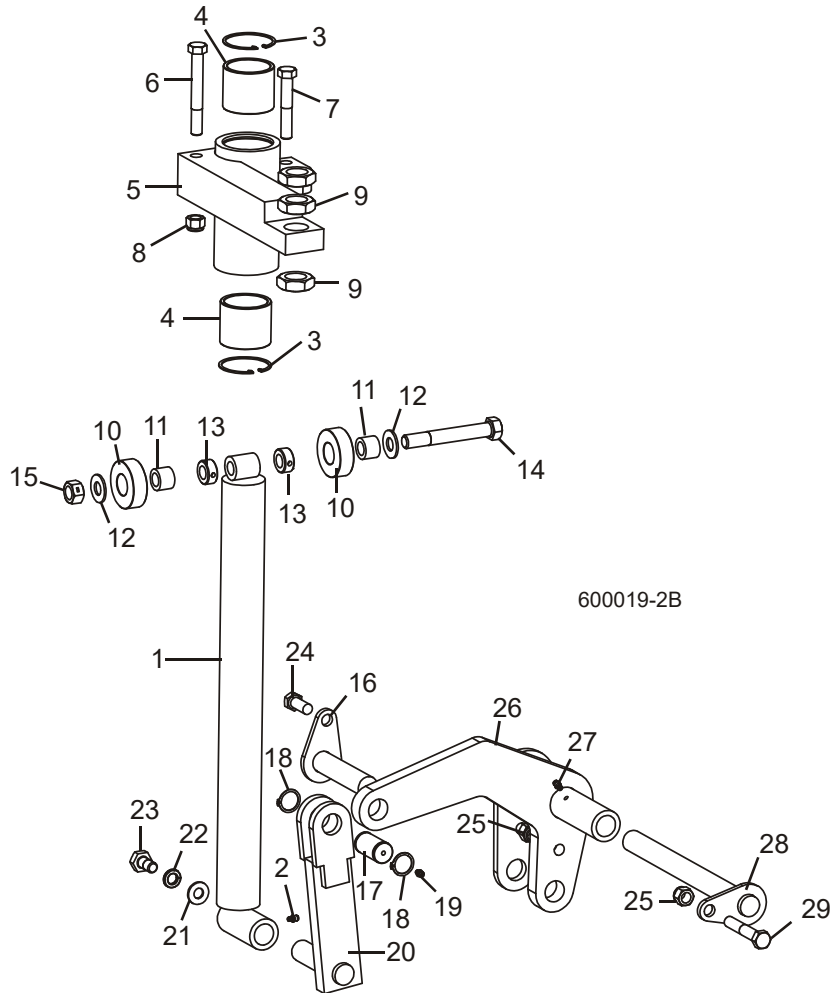

REF	DESCRIPTION (◆ Indicates Parts Available in Assemblies Only)	PART #	QTY.
	SUPPORT ASSEMBLY, VERTICAL HYDRAULIC SIDE	034732	1
1	Rod Weldment, Vertical Side Support	034704	1
2	Fitting, 3/16" Straight Grease	P04107	1
3	Ring, 62mm Din #472 Inside Retaining	F04254-12	2
4	Bushing, Side Support	042262	2
5	Mount Weldment, Vertical Side Support	034703	1
6	Bolt, 1/2-13 x 4" Hex Head Grade 5	F05008-78	1
7	Bolt, 1/2-13 x 3" Hex Head Grade 5	F05008-23	1
8	Nut, 1/2-13 Hex Nylon Lock	F05010-8	2
9	Nut, 1-14 Hex Jam	F05010-118	3
	Roller Kit, Side Support	034733	1
10	Roller, Side Support	016561	2

10

Hydraulic System

Hydraulic Log Side Supports (Rear)

11	Bushing, 5/8" x 1" x 3/4" Bronze	016560	2	
12	Washer, 5/8" SAE Flat	F05011-5	2	
13	Collar, 5/8" Lock	P05035	2	
14	Bolt, 5/8-11 x 4 1/2" Hex Head Grade 5	F05009-10	1	
15	Nut, 5/8-11 Hex Lock	F05010-4	1	
16	PIN WELDMENT, 4 3/8" PIVOT	034726	1	
	PIN ASSEMBLY, SIDE SUPPORT PIVOT	036053	1	
17	Pin, Grooved Pivot	034718 ¹	1	◆
18	Ring, 1" 3100-100 Outside Retaining	F04254-15	2	
19	Fitting, 3/16" Straight Grease	P04107	1	
20	PUSHER WELDMENT, LOWER SIDE SUPPORT	034711	1	
21	WASHER, 9/16" SAE FLAT	F05011-52 ²	1	
22	WASHER, 1/2" SPLIT LOCK	F05011-9	1	
23	BOLT, 1/2-13 X 1" HEX HEAD	F05008-50	1	
24	BOLT, 1/2"-13 X 1 1/4" HEX HEAD GRADE 5	F05008-37	2	
25	NUT, 1/2-13 HEX NYLON LOCK	F05010-8	2	
26	ARM WELDMENT, VERTICAL SIDE SUPPORT REAR LIFT	034716	1	
27	FITTING, 3/16" STRAIGHT GREASE	P04107	1	
28	PIN WELDMENT, 10 7/8" PIVOT	034728	1	
29	BOLT, 1/2-13 X 3" HEX HEAD GRADE 5	F05008-23	1	

¹ Use Pin Assembly 036053 to replace Pin 034718. Pin modified to accept grease fitting (Rev. A1.04).

² Replaces F05011-2 1/2" SAE Flat Washer originally supplied prior to Rev. A2.00. Increased outside diameter improves retainment of pusher weldment.

10.19 Hydraulic Log Side Supports (Link)

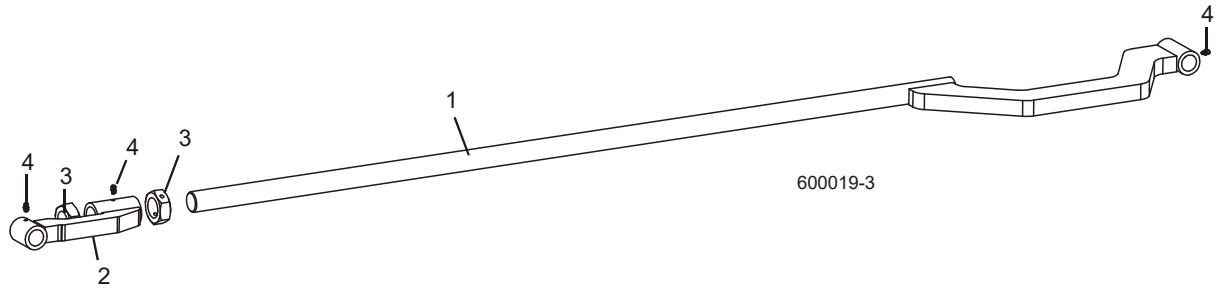

REF	DESCRIPTION (◆ Indicates Parts Available In Assemblies Only)	PART #	QTY.	
1	ROD WELDMENT, SIDE SUPPORT LINK	034725	1	
2	ARM WELDMENT, SIDE SUPPORT LINK	034724	1	
3	NUT, 1 1/4"-12 HEX JAM	F05010-100	2	
4	FITTING, 3/16" STRAIGHT GREASE	P04107	3	

10 Hydraulic System

Hydraulic Log Clamp

10.20 Hydraulic Log Clamp

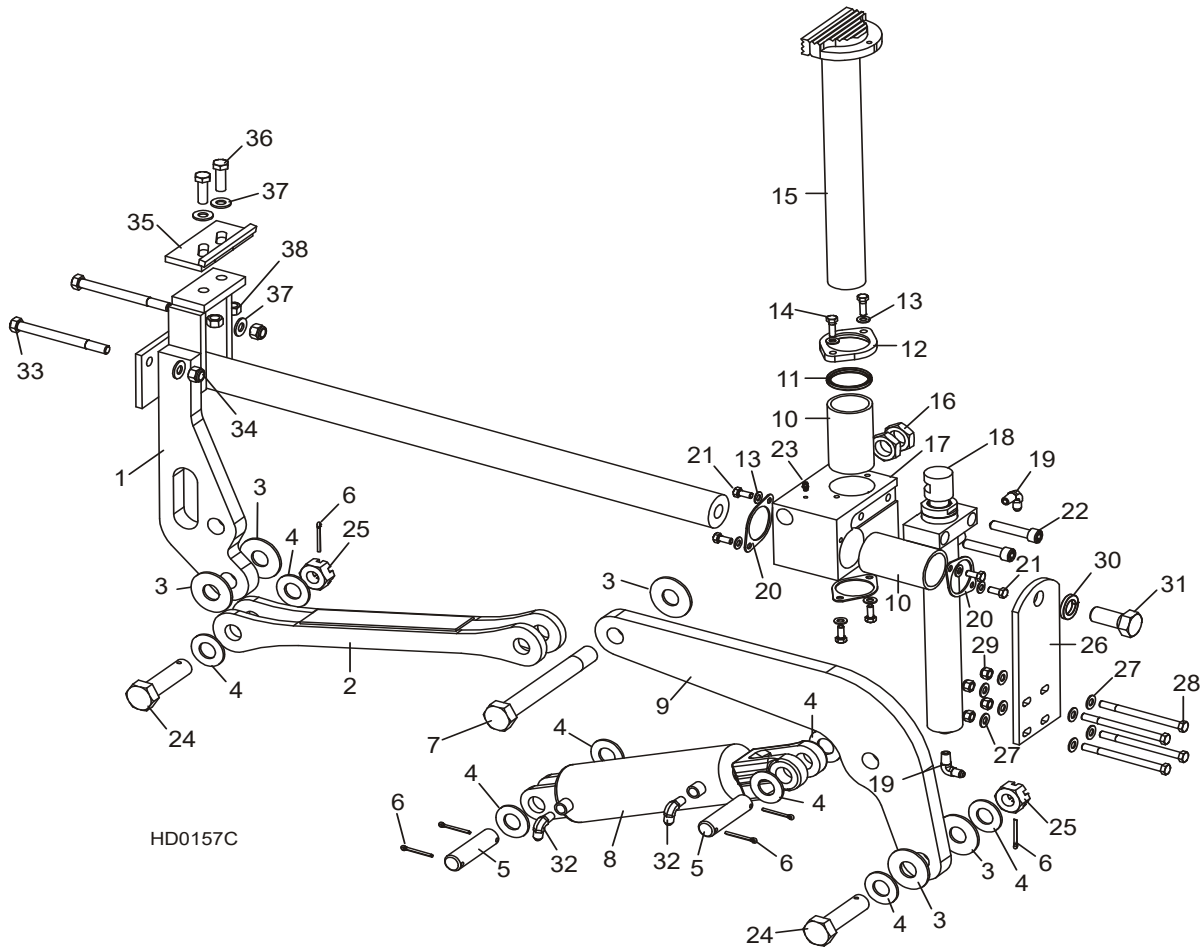

REF	DESCRIPTION (◆ Indicates Parts Available In Assemblies Only)	PART #	QTY.
	CLAMP ASSEMBLY, HYDRAULIC 2-PLANE	017264	1
1	Mount Weldment, Hydraulic Clamp Slide	017265	1
2	Link Weldment, Hydraulic Clamp	017267	1
3	Washer, 1/8" x 2 1/2" Hardened	015057	5
4	Washer, 1" SAE Flat	F05011-28	8
5	Pin, 1" x 3.88"	S09251	2
6	Pin, 3/16" x 1 1/2" Cotter	F05012-23	6
7	Bolt, 1-14 x 8 1/2" Hex Head Grade 8	015049	1
8	Cylinder, 3" x 7" Hydraulic	017275	1
	Seal Kit, Hydraulic Cylinder	P12956	1
9	Arm, Clamp Pivot	017274	1
10	Bushing, Clamp Slide	015088	2
	Wiper Assembly, Vertical Clamp Rod	017271	1

11	Wiper, Vertical Clamp Rod	017273	1	
12	Flange, Vertical Clamp Rod Wiper	017272	1	
13	Washer, 5/16" SAE Flat	F05011-17	8	
14	Bolt, 5/16-18 x 1" Hex Head	F05006-1	2	
15	Clamp Weldment, Vertical	015043	1	
16	Nut, 1-14 Hex Jam	F05010-118	2	
17	Block, Hydraulic Clamp Slide	017270	1	
18	Cylinder Weldment, Vertical Clamp Hydraulic	015050	1	
	Seal Kit, Hydraulic Cylinder	016204	1	
	Instruction Sheet, Vertical Clamp Seal Replacement	016204-1009	1	
19	Fitting, 1/4" NPT x 1/4" JIC Elbow	P09142	2	
20	Retainer, Clamp Bushing	017242	3	
21	Bolt, 5/16-18 x 3/4" Hex Head	F05006-5	6	
22	Bolt, 1/2-13 x 2 1/2" Socket Head	F05008-39	2	
23	Fitting, 3/16" Straight Grease	P04107	1	
24	Bolt, 1-14 x 3 3/4" Hex Head Grade 8 w/Hole	015072 ¹	2	
25	Nut, 1-14 Slotted Hex	F05010-163	2	
26	Plate, Log Clamp Mount	015068	1	
27	Washer, 3/8" SAE Flat	F05011-3	8	
28	Bolt, 3/8-16 x 5" Hex Head	F05007-5	4	
29	Nut, 3/8-16 Hex Nylon Lock	F05010-10	4	
30	Washer, 7/8" Split Lock	F05011-46	1	
31	Bolt, 7/8-14 x 2" Hex Head Grade 5	F05014-2	1	
32	Fitting, 1/4" NPT - 3/8" JIC Elbow	015491	2	
33	Bolt, 1/2-13 x 5 1/2" Hex Head Grade 5	F05008-28	2	
34	Nut, 1/2-13 Hex Nylon Lock	F05010-8	2	
	Clamp Stop Kit, Hydraulic Log	K09485	1	
35	Plate, Clamp Stop	W09404	1	
36	Bolt, 1/2-13 X 1 1/2" Hex Head Grade 5	F05008-33	2	
37	Washer, 1/2" SAE Flat	F05011-2	2	
38	Nut, 1/2-13 Hex Lock	F05010-3	2	

¹ Bolt shortened from 4" to 3 3/4" to reduce interference on LT60HD/60HD models. 4" bolts can be used on other models (1/04).

10.21 Hydraulic Toe Board

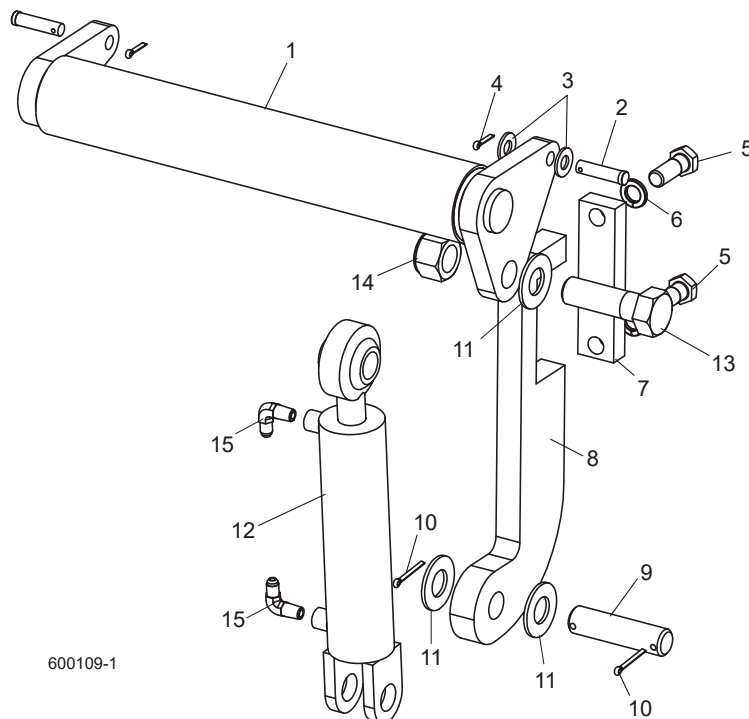

REF	DESCRIPTION (◆ Indicates Parts Available In Assemblies Only)	PART #	QTY.
1	TOE BOARD WELDMENT, HYDRAULIC	W13025	2
2	PIN, 1/2-1 3/4 CLEVIS	F05012-82	4
3	WASHER, 1/2" SAE FLAT	F05011-2 ¹	4
4	PIN, 1/8 X 3/4" COTTER	F05012-3	4
5	BOLT, 5/8-11 X 1 3/4" HEX HEAD	F05009-33	4
6	WASHER, 5/8" SPLIT LOCK	F05011-27	4
7	PLATE, HYDRAULIC TOEBOARD MOUNT	S13023	2
8	BRACKET, HYDRAULIC TOEBOARD MOUNT	S13022	2
9	PIN, CYLINDER MOUNT	S09251	2
10	PIN, 3/16" X 1 1/2" COTTER	F05012-23	4
11	WASHER, 1" SAE FLAT	F05011-28	6
12	CYLINDER, 1 1/2" X 6" HYDRAULIC TOE BOARD	014482	2
	Seal Kit, 1 1/2" x 6" Hydraulic Cylinder	014547	1
13	BOLT, 1-8 X 3 1/4" HEX HEAD GRADE 5	F05009-51	2
14	NUT, 1-8 HEX NYLON LOCK	F05010-109	2
15	FITTING, 1/4" NPT X 1/4" JIC MALE ELBOW	P09142 ²	4

¹ four washers removed from frame-side pivots to increase clearance for easier assembly.

² Elbow fitting P09142 replaces straight fitting P09143 in top cylinder port to eliminate interference with frame (12/07).

INDEX

A

autoclutch assembly 4-5

B

battery box 5-22

bed rails

- front/rear 8-1
- middle front 8-3
- middle rear 8-4
- pivot 8-11

belt tensioner 4-2

blade guide arm

- drive 2-19

blade guides

- drive side roller 2-10, 2-13, 2-16
- idle side roller 2-1, 2-4
- throat screw 4-1

blade tensioner 3-5, 3-8

blade wheels

- drive side 3-1
- idle side 3-3

board dragback 4-10, 4-11

board return 4-7, 4-8, 4-9

board return table 8-8, 8-10

brake assembly 4-4

C

control box 5-1, 5-4, 5-7, 5-10, 5-13, 5-16

- drum switches 5-19
- remote junction (AC) 5-28
- remote power 5-26
- remote power box door 5-30
- remote power w/accuset 5-26

covers

- blade housing 4-4, 4-6
-

D

debarker wire box/hole plugs 4-9

decals

- frame 8-17
 - saw head 4-3
-

F

feed chain 7-5

H

hydraulic

- command control 10-2, 10-4
- control box (230/460V AC) 10-11
- control box (575V AC) 10-13
- hoses 10-1
- log clamp 10-38
- log loader 10-23, 10-25
- log turner 10-27, 10-29
- power strip (AC) 10-21
- power strip (DC) 10-19
- pump box (AC) 10-9
- pump box (DC) 10-6, 10-15
- side supports 10-31, 10-33
- side supports (link) 10-37
- side supports (rear) 10-35
- toe board 10-40
- valve (AC) 10-17
- valve (DC) 10-15

M

- manuals 9-1

P

- parts list
 - how to use 1-1
- power feed 7-3

R

- remote cable box 8-24
- remote cable chain 8-18, 8-19
 - bottom mount 8-20
 - top mount 8-21
 - tray & front pivot 8-22
- remote cable chain support bracket 8-23

- rest pin 8-16

S

- sawdust chute 4-8
- side supports 8-13

T

- track rollers
 - lower 7-6, 7-8
 - upper 7-1

U

- up/down
 - blade scales 6-5
 - chain & sprockets 6-6
 - drive 6-8, 6-10, 6-12
 - saw head mount 6-1, 6-3

W

- water lube
 - bottle/tray 4-1