

**Wood-Mizer[®] Sawmill
Parts Manual**

LT15 Start

rev. A1.00-A1.04

Safety is our #1 concern!

November 2017

Form #2304

Models Affected:

LT15EH15NS
LT15G14S



WARNING! Read and understand this manual before using this machine.

California

Proposition 65 Warning



WARNING: Breathing gas/diesel engine exhaust exposes you to chemicals known to the State of California to cause cancer and birth defects or other reproductive harm.

Always start and operate the engine in a well-ventilated area.
If in an enclosed area, vent the exhaust to the outside.
Do not modify or tamper with the exhaust system.
Do not idle the engine except as necessary.

For more information go to www.P65warnings.ca.gov.



WARNING: Drilling, sawing, sanding or machining wood products can expose you to wood dust, a substance known to the State of California to cause cancer. Avoid inhaling wood dust or use a dust mask or other safeguards for personal protection.

For more information go to www.P65Warnings.ca.gov/wood.

Active Patents assigned to Wood-Mizer, LLC

Wood-Mizer, LLC has received patents that protect our inventions which are a result of a dedication to research, innovation, development, and design. Learn more at: woodmizer.com/patents

©2025 Wood-Mizer LLC

Printed in the United States of America, all rights reserved. No part of this manual may be reproduced in any form by any photographic, electronic, mechanical or other means or used in any information storage and retrieval system without written permission from

Wood-Mizer, LLC
8180 West 10th Street
Indianapolis, Indiana 46214

SECTION 1 REPLACEMENT PARTS

1.1 How To Use The Parts List..... 1-1
 To Order Parts 1-1
 1.2 Sample Assembly..... 1-1
 1.3 Torque Values..... 1-2

SECTION 2 BLADE GUIDE ROLLERS & ARM

2.1 Blade Guide Assembly, Idle Side 2-1
 2.2 Blade Guide Assembly, Drive Side 2-3
 2.3 Blade Guide Arm 2-5

SECTION 3 BLADE WHEELS & TENSIONER

3.1 Blade Drive Assembly 3-1
 3.2 Idle Blade Wheel Assembly..... 3-2
 3.3 Blade Tensioner Assembly 3-3
 3.4 Water Lube Assembly..... 3-4
 3.5 Saw Head Decals 3-6
 3.6 Blade Housing Covers & Wood Blocks 3-8

SECTION 4 UP/DOWN SYSTEM

4.1 Saw Head Mount..... 4-1
 4.2 Up/Down Reducer Assembly (Optional)..... 4-3
 4.3 Manual Crank Assembly 4-4
 4.4 Manual Crank Mount & Sprocket Parts..... 4-6

SECTION 5 FEED SYSTEM & TRACK ROLLERS

5.1 Track Rail, Rollers, & Travel Pins..... 5-1
 5.2 Rail Wiper 5-3
 5.3 Feed Stop Brackets..... 5-5
 5.4 Manual Push Handle 5-6

SECTION 6 BED FRAME ASSEMBLY

6.1 Log Wedge, Loading Ramps, & Cant Hook (Optional) 6-1
 6.2 Bed Section & Connecting Hardware 6-2
 6.3 Leg Assembly 6-3
 6.4 Log Side Support Assembly 6-4
 6.5 Log Clamp 6-5

SECTION 7 MISCELLANEOUS

7.1 Replacement Manuals 7-1

SECTION 1 REPLACEMENT PARTS

1.1 How To Use The Parts List

- Use the table of contents to locate the assembly that contains the part you need.
- Go to the appropriate section and locate the part in the illustration.
- Use the number pointing to the part to locate the correct part number and description in the table.
- Parts shown indented under another part are included with that part.

To Order Parts

- From the continental US, call **1-800-525-8100** to order parts. Have your customer number, vehicle identification number, and part numbers ready when you call.
- From other international locations, contact the Wood-Mizer distributor in your area for parts.

1.2 Sample Assembly



REF	PART #	DESCRIPTION	COMMENTS	QTY.
	012345	SAMPLE ASSEMBLY, COMPLETE	INCLUDES ITEMS 1-6	1
1	F02222-22	Sample Part		1
2	F03333-33	Sample Part		2
	098765	Sample Subassembly	Includes items 3-6	1
3	S04444-44	Subassembly Sample Part		1
4	K55555	Subassembly Sample Part		1
	054321	Sample Sub-Subassembly	Includes items 5-6	2
5	022222	Sub-Subassembly Sample Part		1
6	F10234-56	Sub-Subassembly Sample Part		1

The Sample Assembly, Complete, part number 02345 (top level assembly) includes two parts (F0222-22 and F0333-33) and the 098765 subassembly.

Subassembly 098765 contains two parts(S04444-44 and K55555) and two copies of sub-subassembly 054321.

Each sub-subassembly 054321 contains two parts (022222 and F10234-56).

1.3 Torque Values

Grade		Units	SAE 5	SAE 8
Grade Mark				
Bolt Dia.	Threads. Per In.	Units	SAE 5	SAE 8
6	32	in-lbs (Nm)	20 (2.3)	-
8	32	in-lbs (Nm)	24 (2.7)	30 (3.4)
10	24	in-lbs (Nm)	35 (4.0)	45 (5.1)
10	32	in-lbs (Nm)	40 (4.5)	50 (5.7)
12	24	in-lbs (Nm)	50 (5.7)	65 (7.3)
1/4	20	in-lbs (Nm)	95 (10.7)	125 (14.1)
1/4	28	in-lbs (Nm)	95 (10.7)	150 (17.0)
5/16	18	ft-lbs (Nm)	17 (22.6)	23 (31.2)
5/16	24	ft-lbs (Nm)	20 (27.1)	25 (33.8)
3/8	16	ft-lbs (Nm)	30 (40.7)	40 (54.2)
3/8	24	ft-lbs (Nm)	35 (47.5)	45 (61.0)
7/16	14	ft-lbs (Nm)	50 (67.8)	65 (88.1)
7/16	20	ft-lbs (Nm)	55 (74.6)	70 (94.9)
1/2	13	ft-lbs (Nm)	75 (101.7)	100 (135.6)
1/2	20	ft-lbs (Nm)	85 (115.3)	110 (149.2)
9/16	12	ft-lbs (Nm)	105 (142.4)	135 (183.1)
9/16	18	ft-lbs (Nm)	115 (155.9)	150 (203.4)
5/8	11	ft-lbs (Nm)	150 (203.4)	195 (264.4)
5/8	18	ft-lbs (Nm)	160 (217.0)	210 (284.8)
3/4	10	ft-lbs (Nm)	170 (230.5)	220 (298.3)
3/4	16	ft-lbs (Nm)	175 (237.3)	225 (305.1)
7/8	9	ft-lbs (Nm)	302 (409.5)	473 (640.9)
7/8	14	ft-lbs (Nm)	300 (406.8)	400 (542.4)
1	8	ft-lbs (Nm)	466 (631.8)	714 (967.4)

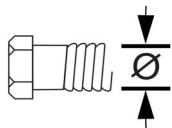

Metric Bolt Head Identification



Metric Grade 8.8



Metric Grade 10.9

COARSE THREAD					FINE THREAD				Wrench Size	
Diameter & Thread Pitch	Metric 8.8		Metric 10.9		Diameter & Thread Pitch	Metric 8.8		Metric 10.9		
	N-m	lbs-ft	N-m	lbs-ft		N-m	lbs-ft	N-m		lbs-ft
6 x 1.0	8	6	11	8					10 mm	
8 x 1.25	20	15	27	20	8 x 1.0	21	16	29	22	13 mm
10 x 1.5	39	29	54	40	10 x 1.25	41	30	57	42	16 mm
12 x 1.75	68	50	94	70	12 x 1.25	75	55	103	76	18 mm
14 x 2.0	109	80	151	111	14 x 1.5	118	87	163	120	21 mm
16 x 2.0	169	125	234	173	16 x 1.5	181	133	250	184	24 mm
18 x 2.5	234	172	323	239	18 x 1.5	263	194	363	268	27 mm
20 x 2.5	330	244	457	337	20 x 1.5	367	270	507	374	30 mm
22 x 2.5	451	332	623	460	22 x 1.5	495	365	684	505	34 mm
24 x 3.0	571	421	790	583	24 x 2.0	623	459	861	635	36 mm
30 x 3.0	1175	867	1626	1199	30 x 2.0	1258	928	1740	1283	46 mm

SECTION 2 BLADE GUIDE ROLLERS & ARM

2.1 Blade Guide Assembly, Idle Side

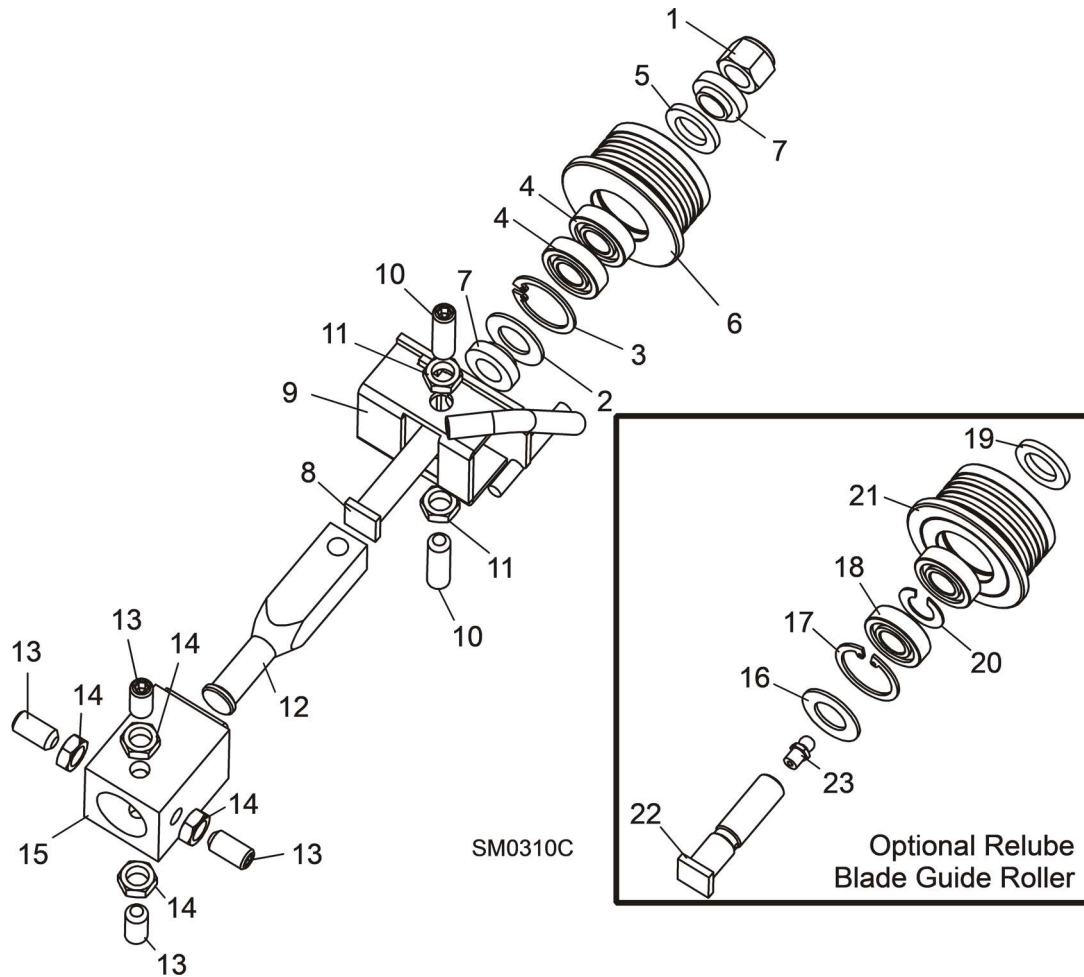

REF	PART #	DESCRIPTION	COMMENTS	QTY.
	A08197	BLADE GUIDE ASSEMBLY, COMPLETE IDLE SIDE		1
1	F05010-15	Nut, 1/2-20 Hex Nylon Lock		1
	A04925	Roller Assembly, Blade Guide (standard)		1
	K07079	Bearing Kit, Blade Guide Rebuild		1
2	P04252	Washer, 5/8" White Felt		1
3	F04254-1	Ring, 1 1/8" Interior Retaining		1
4	015975	Bearing, R8-2RS Blade Guide	Available in assemblies only.	2
5	P06455	Washer, 5/8" Gray Felt		1
	F05005-105	Screw, 1/4-28 x 1/4" Socket Head Cup Point Set Black Oxide		1
	057407-1507	Instruction Sheet, Blade Guide Rebuild		1
6	S04250	Roller, Flanged Blade Guide	Available in assemblies only.	1
	A04925-364	Instruction Sheet, Blade Guide Roller Replacement		1
7	S04253	Spacer, Blade Guide		2

REF	PART #	DESCRIPTION	COMMENTS	QTY.
8	036373	Bolt, Blade Guide Roller		1
9	W08495	Bracket, Blade Guide Idle Side With Water Tube		1
10	F05007-96	Screw, 3/8-24 X 1 1/4" Stainless Steel Socket Head Flat Point		2
11	F05010-22	Nut, 3/8-24 Jam		2
12	S08196	Shaft, Blade Guide Adjustment		1
13	F05007-95	SCREW, 3/8-24 X 3/4" STAINLESS STEEL SOCKET HEAD FLAT POINT		4
14	F05010-22	NUT, 3/8-24 JAM		4
15	W08159	TUBE, BLADE GUIDE MOUNT (See Section 2.4)		1
	016568	ROLLER ASSEMBLY, BLADE GUIDE RELUBE (OPTIONAL)		1
	057407	Bearing Kit, Relube Blade Guide Rebuild		1
16	P04252	Washer, 5/8" White Felt		1
17	F04254-1	Ring, 1 1/8" Interior Retaining		1
18	015975	Bearing, R8-2RS Blade Guide	Available in assemblies only. Bearing must be modified for use with relube roller assemblies. Remove one seal from each bearing, place open sides facing each other and place spacer 035411 between bearings.	2
19	P06455	Washer, 5/8" Gray Felt		1
	057407-1507	Instruction Sheet, Blade Guide Rebuild		1
20	035411	Spacer, Blade Guide Bearing		1
21	035426	Roller, Flanged Blade Guide Relube	Available in assemblies only.	1
	A04925-364	Instruction Sheet, Blade Guide Roller Replacement		1
22	S08192	BOLT, BLADE GUIDE ROLLER (RELUBE ONLY)		1
23	P05060	FITTING, 1/4-28 GREASE (RELUBE ONLY)		1

2.2 Blade Guide Assembly, Drive Side

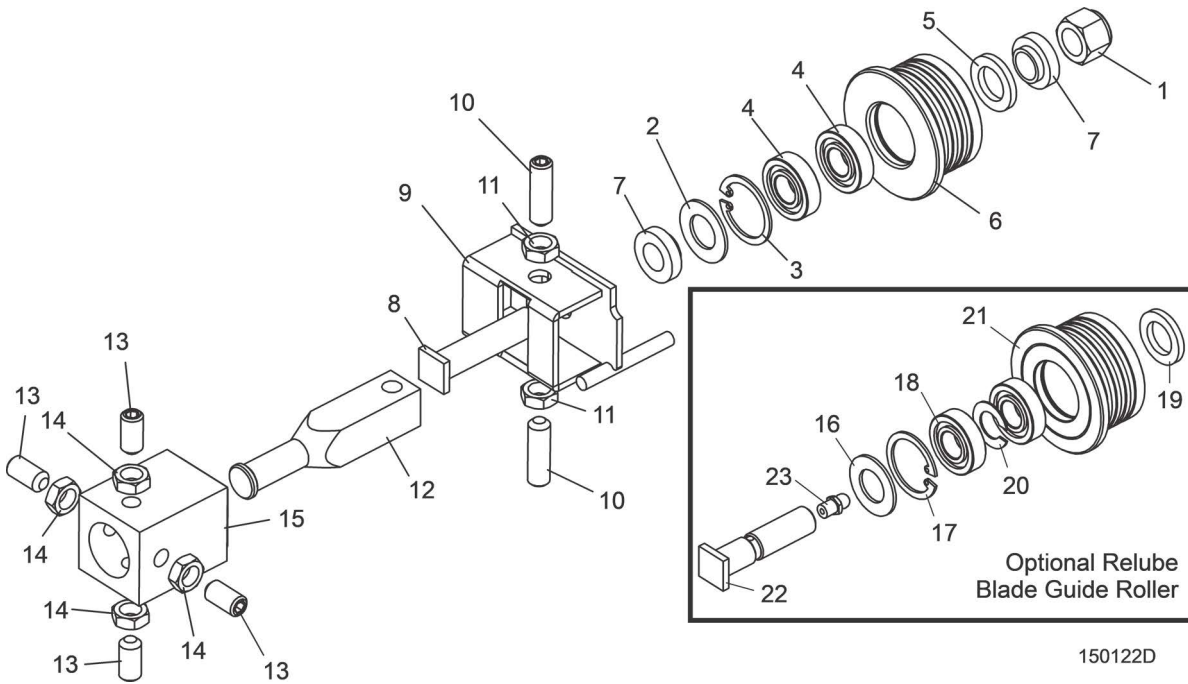

150122D

REF	PART #	DESCRIPTION	COMMENTS	QTY.
	A08191	BLADE GUIDE ASSEMBLY, COMPLETE DRIVE SIDE		1
1	F05010-15	Nut, 1/2-20 Hex Nylon Lock		1
	A04925	Roller Assembly, Blade Guide (standard)		1
	K07079	Bearing Kit, Blade Guide Rebuild		1
2	P04252	Washer, 5/8" White Felt		1
3	F04254-1	Ring, 1 1/8" Interior Retaining		1
4	O15975	Bearing, R8-2RS Blade Guide	Available in assemblies only.	2
5	P06455	Washer, 5/8" Gray Felt		1
	F05005-105	Screw, 1/4-28 x 1/4" Socket Head Cup Point Set Black Oxide		1
	057407-1507	Instruction Sheet, Blade Guide Rebuild		1
6	S04250	Roller, Flanged Blade Guide	Available in assemblies only.	1
	A04925-364	Instruction Sheet, Blade Guide Roller Replacement		1
7	S04253	Spacer, Blade Guide		2
8	O36373	Bolt, Blade Guide Roller		1
9	W08482	Bracket, Blade Guide Drive Side		1
10	F05007-96	Screw, 3/8-24 X 1 1/4" Stainless Steel Socket Head Flat Point		2
11	F05010-22	Nut, 3/8-24 Jam		2
12	S08196	Shaft, Blade Guide Adjustment		1
13	F05007-95	SCREW, 3/8-24 X 3/4" STAINLESS STEEL SOCKET HEAD FLAT POINT SET		3
14	F05010-22	NUT, 3/8-24 JAM		4
15	W08159	TUBE WELDMENT, BLADE GUIDE MOUNT (Part of saw frame weldment)		1

REF	PART #	DESCRIPTION	COMMENTS	QTY.
	016568	ROLLER ASSEMBLY, BLADE GUIDE RELUBE (OPTIONAL)		1
	057407	Bearing Kit, Relube Blade Guide Rebuild		1
16	P04252	Washer, 5/8" White Felt		1
17	F04254-1	Ring, 1 1/8" Interior Retaining		1
18	015975	Bearing, R8-2RS Blade Guide	Available in assemblies only. Bearing must be modified for use with relube roller assemblies. Remove one seal from each bearing, place open sides facing each other and place spacer 035411 between bearings.	2
19	P06455	Washer, 5/8" Gray Felt		1
20	035411	Spacer, Blade Guide Bearing		1
	057407-1507	Instruction Sheet, Blade Guide Rebuild		1
21	035426	Roller, Flanged Blade Guide Relube	Available in assemblies only.	1
	A04925-364	Instruction Sheet, Blade Guide Roller Replacement		1
22	S08192	BOLT, BLADE GUIDE ROLLER (RELUBE ONLY)		1
23	P05060	FITTING, 1/4-28 GREASE (RELUBE ONLY)		1

2.3 Blade Guide Arm

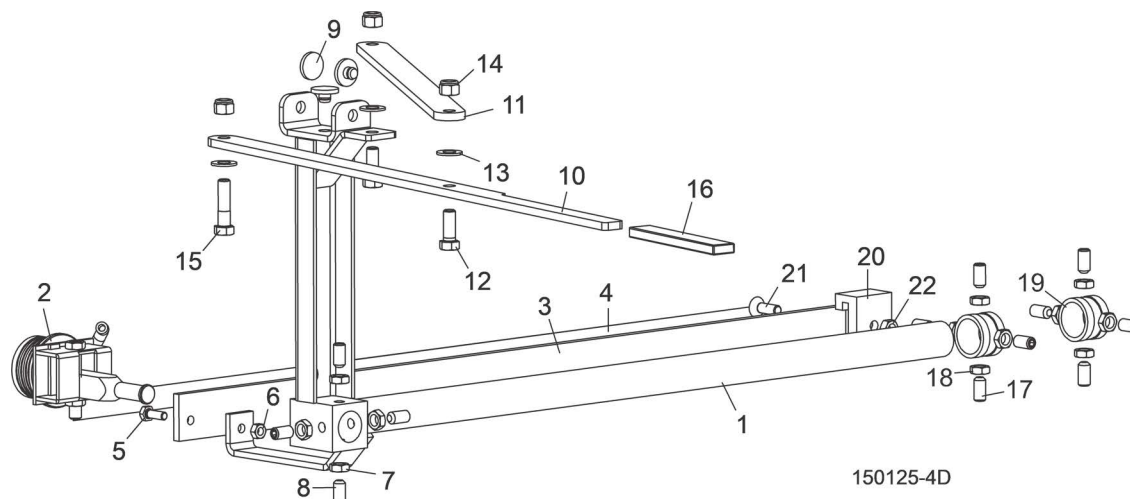

REF	PART #	DESCRIPTION	COMMENTS	QTY.
	046966	ARM ASSEMBLY, LT15 BLADE GUIDE (2004)		1
1	046965	Arm Weldment, LT15 Blade Guide (2004)		1
2		Blade Guide Parts ((See Section 2.1))		
3	014955	Guard, LT15 Blade Guide Arm		1
4	015849	Decal, LT15 Blade Guide Arm		1
5	F05005-1	Bolt, 1/4-20 x 3/4" Hex Head Full Thread		1
6	F05010-21	Nut, 1/4-20 Hex Lock		1
7	F05010-22	Nut, 3/8-24 Hex Jam		4
8	F05007-95	Screw, 3/8-24 x 3/4" Socket Head Flat Point Set		4
9	014973	Pad, Blade Guide Slide		3
10	076118	PLATE, LT15 WIDE BLADE GUIDE ARM ADJUSTMENT		1
11	076117	PLATE, LT15 WIDE BLADE GUIDE ARM LINK		1
12	F05007-87	BOLT, 3/8-16 X 1" HEX HEAD GRADE 5		2
13	F05011-3	WASHER, 3/8" SAE FLAT		3
14	F05010-10	NUT, 3/8-16 HEX NYLON LOCK		3
15	F05007-78	BOLT, 3/8-16 X 1 1/2" HEX HEAD GRADE 5		1
16	049008	GRIP, FOAM FLAT 1/4 X 3/4		1
17	F05007-95	SCREW, 3/8-24 X 3/4" STAINLESS SOCKET HEAD FLAT POINT SET		8
18	F05010-22	NUT, 3/8-24 HEX JAM		8
19	015899	BUSHING, BLADE GUIDE ARM		2
20	014882	BRACKET, BLADE GUIDE ARM GUIDE		1
21	F05006-124	BOLT, 5/16-18 X 1" FLAT HEAD SOCKET		1
22	F05010-6	NUT, 5/16-18 HEX LOCK		1

SECTION 3 BLADE WHEELS & TENSIONER

3.1 Blade Drive Assembly

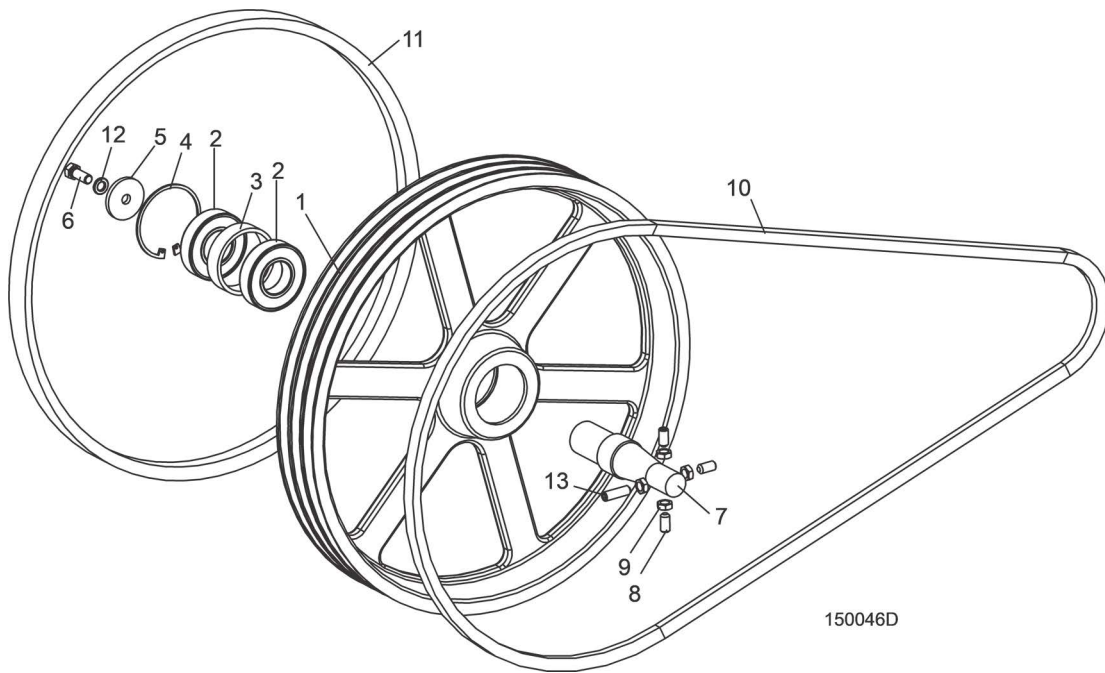

REF	PART #	DESCRIPTION	COMMENTS	QTY.
		BLADE WHEEL BRAKE PARTS	See Section SECTION 5	
	014995	WHEEL ASSEMBLY, DRIVE SIDE BLADE (E10)		1
	036657	WHEEL ASSEMBLY, DRIVE SIDE BLADE(D17, G19 & G25)		1
1	014727	Wheel, Drive Side Blade (E10)		1
	047702	Wheel, Drive Side Blade (D17, G19 & G25)		1
2	014811	Bearing, #6207 2RS		2
3	014730	Spacer, Drive Bearing		1
4	F04254-30	Ring, 3.121 IR Beveled Retaining		1
5	014728	WASHER, DRIVE WHEEL RETAINING		1
6	F05007-87	BOLT, 3/8-16 X 1" HEX HEAD		1
7	014729	SHAFT, LT15 DRIVE SIDE BLADE WHEEL		1
8	F05007-95	SCREW, 3/8-24 X 3/4" FLAT POINT SOCKET		3
9	F05010-22	NUT, 3/8-24 HEX JAM		4
10		BELT, DRIVE	See Section SECTION 5	1
11	P04185	BELT, B57		1
	F05011-4	WASHER, 3/8" SPLIT LOCK		1
13	F05007-96	SCREW, 3/8-24 X 1 1/4" FLAT POINT SOCKET		1

3.2 Idle Blade Wheel Assembly

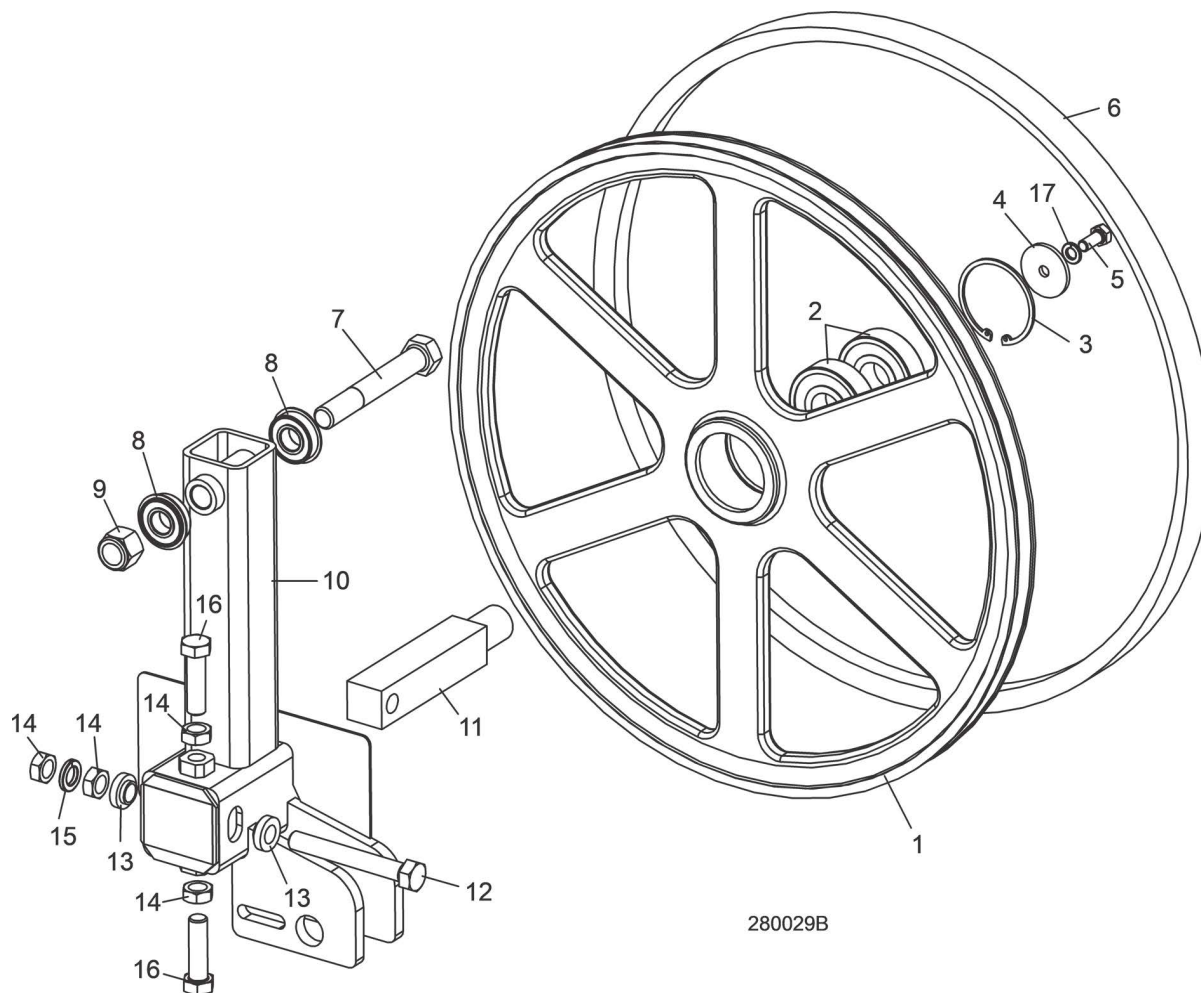

REF	PART #	DESCRIPTION	COMMENTS	QTY.
	A08218	WHEEL ASSEMBLY, IDLE SIDE BLADE		1
1	P08125	Wheel, Idle Side Blade	Available in assemblies only.	1
2	P08066	Bearing, Idle Side Blade Wheel #6305-AA, C3, ABEC-1, SRI-2 Grease		2
3	F04254-21	Ring, 2 7/16" Internal Retaining		1
4	S08220	WASHER, IDLE BLADE WHEEL RETAINER		1
5	F05006-102	BOLT, 5/16-18 X 3/4" HEX HEAD		1
6	P04185	BELT, BLADE WHEEL B57		1
7	F05009-3	BOLT, 5/8-11 X 4 1/2" HEX HEAD		1
8	014834	BEARING, 5/8" I.D. W/SNAP RING		2
9	F05010-34	NUT, 5/8-11 HEX NYLON LOCK		1
10	049349	IDLER WELDMENT, BLADE WHEEL		1
11	S12565	SHAFT, IDLE WHEEL		1
12	F05008-111	BOLT, 1/2-20 X 3 3/4" HEX HEAD FULL THREAD GRADE 2		1
13	S04253	SPACER, 1/2" I.D. FLANGED		2
14	F05010-16	NUT, 1/2-20 HEX JAM		4
15	F05011-9	WASHER, 1/2" SPLIT LOCK		1
16	F05008-127	BOLT, 1/2-20 X 1 3/4" HEX HEAD GRADE 5		2
17	F05011-13	WASHER, 5/16" SPLIT LOCK		1

3.3 Blade Tensioner Assembly

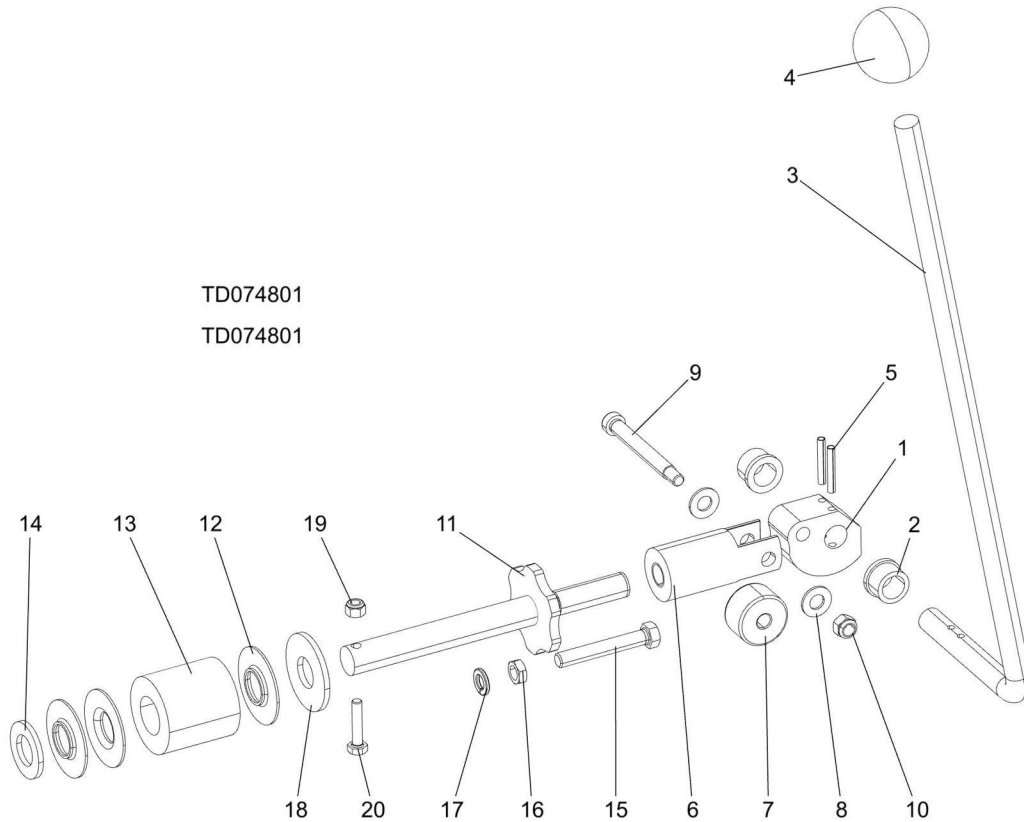

TD074801
TD074801

REF	PART #	DESCRIPTION	COMMENTS	QTY.
	074801	TENSION ASSEMBLY, CAM ACTUATED BLADE		1
1	049104	Cam, Tension		1
2	P05135	Bushing, 5/8" x 7/8" x 1/2" Bronze		2
3	103801	Handle, Blade Tensioner, LT15/28/35		1
4	P04211	Knob, 5/8-18 Ball		1
5	F05012-16	Pin, 3/16" x 1 1/4" Roll		2
6	128072	Block, Tensioner Bearing Mount		1
7	048219	Cam Follower, 3/8" x 1 3/8" x 13/16"		1
8	F05011-3	Washer, 3/8" SAE Flat		2
9	F05007-202	Bolt, 3/8 x 2 1/2" Socket Head Shoulder		1
10	F05010-58	Nut, 5/16-18 Hex Nylon Lock		1
11	038642	Shaft Weldment, Blade Tension		1
12	014925	Guide, Tension Handle		3
13	014828	Spring, Rubber Tensioner Blade		1
14	F05011-62	Washer, 3/4" SAE Flat		1
15	F05007-157	Bolt, 3/8-16 x 2 1/2" Hex Head Full Thread		1
16	F05010-29	Nut, 3/8-16 Jam		1
17	F05011-4	Washer, 3/8" Split Lock		1
18	F05011-29	Washer, 3/4" USS Flat		1
19	F05010-69	Nut, 1/4-20 Nylock		1
20	F05005-116	Bolt, 1/4-20x1 1/4 HH Gr5		1

3 Saw Head Assemblies

Water Lube Assembly

3.4 Water Lube Assembly

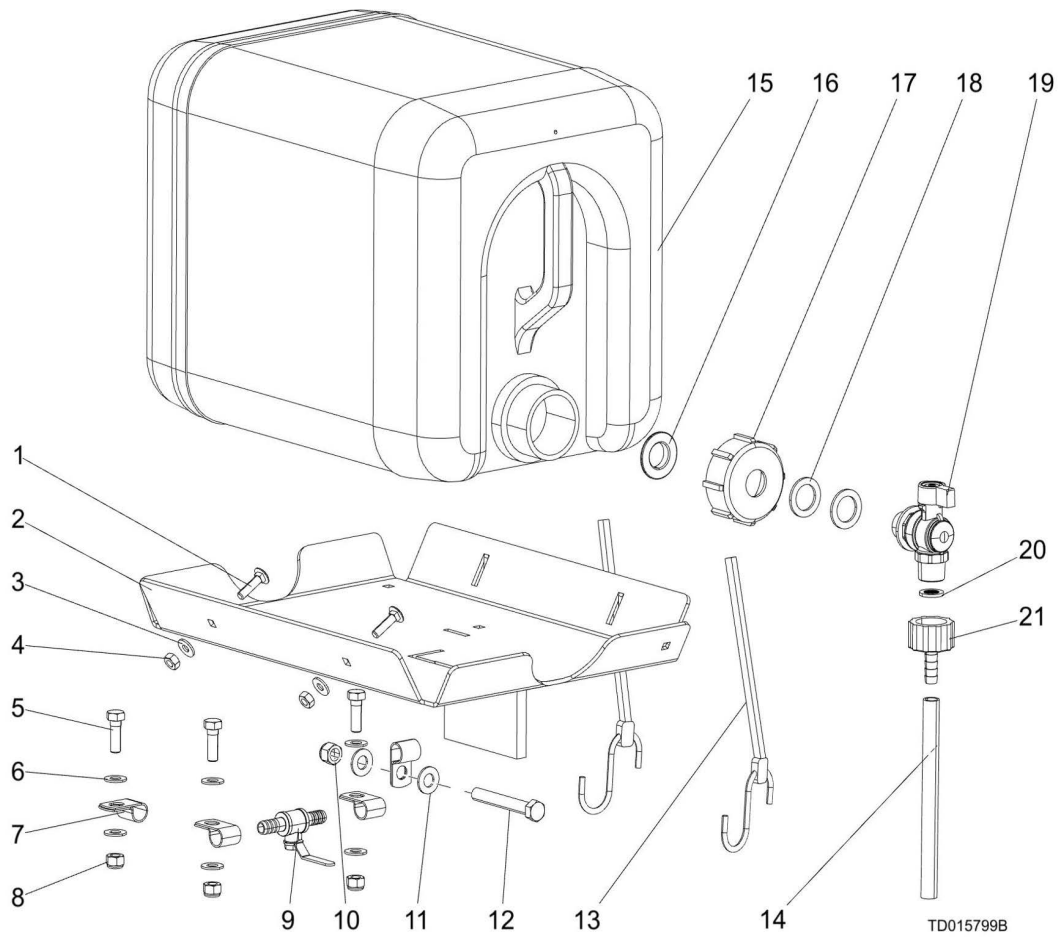

REF	PART #	DESCRIPTION	COMMENTS	QTY.
	015799	WATER LUBE ASSEMBLY		1
1	F05005-34	Bolt, 1/4-20 X 1 Carr		2
2	015798	Tray Weldment, Water Bottle LT15		1
3	F05011-11	Washer, 1/4 SAE Flat		2
4	F05010-21	Nut, 1/4-20 Swaged		2
5	F05006-1	Bolt, 5/16-18x1 HH Gr2		3
6	F05011-17	Washer, 5/16 SAE Flat		6
7	P07584	Clamp, 1/2EMT Coated		4
8	F05010-58	Nut, 5/16-18 Nyl Lock		3
9	065635	Valve, 1/4Turn Ball 3/8 Hose Barbs		1
10	F05010-10	Nut, 3/8-16 Hex Nyl Lock		1
11	F05011-3	Washer, 3/8 Flat SAE		2
12	F05007-230	Bolt, 3/8-16x2 3/4 FT Gr5		1
13	P11668	Strap, 20 Rubber W/Hooks		2
14	R01885	Hose, Water Lube Stock		12.83'

REF	PART #	DESCRIPTION	COMMENTS	QTY.
	601615	Assembly, Water Bottle		1
15	513866	Bottle, Water		1
		Assembly, Cap w/ Valve		
16	625839	Nut, Brass 1/2" for Water Bottle		1
17	550785	Cap, Water Bottle		1
18	550780	O-Ring, 20X30X2		2
19	625845	Valve	Available in assembly only	1
20	550778	Gasket, 1/2" w/Strainer		1
21	550777	Fitting, G3/4" X 10mm Hose Barb		1

3.5 Saw Head Decals

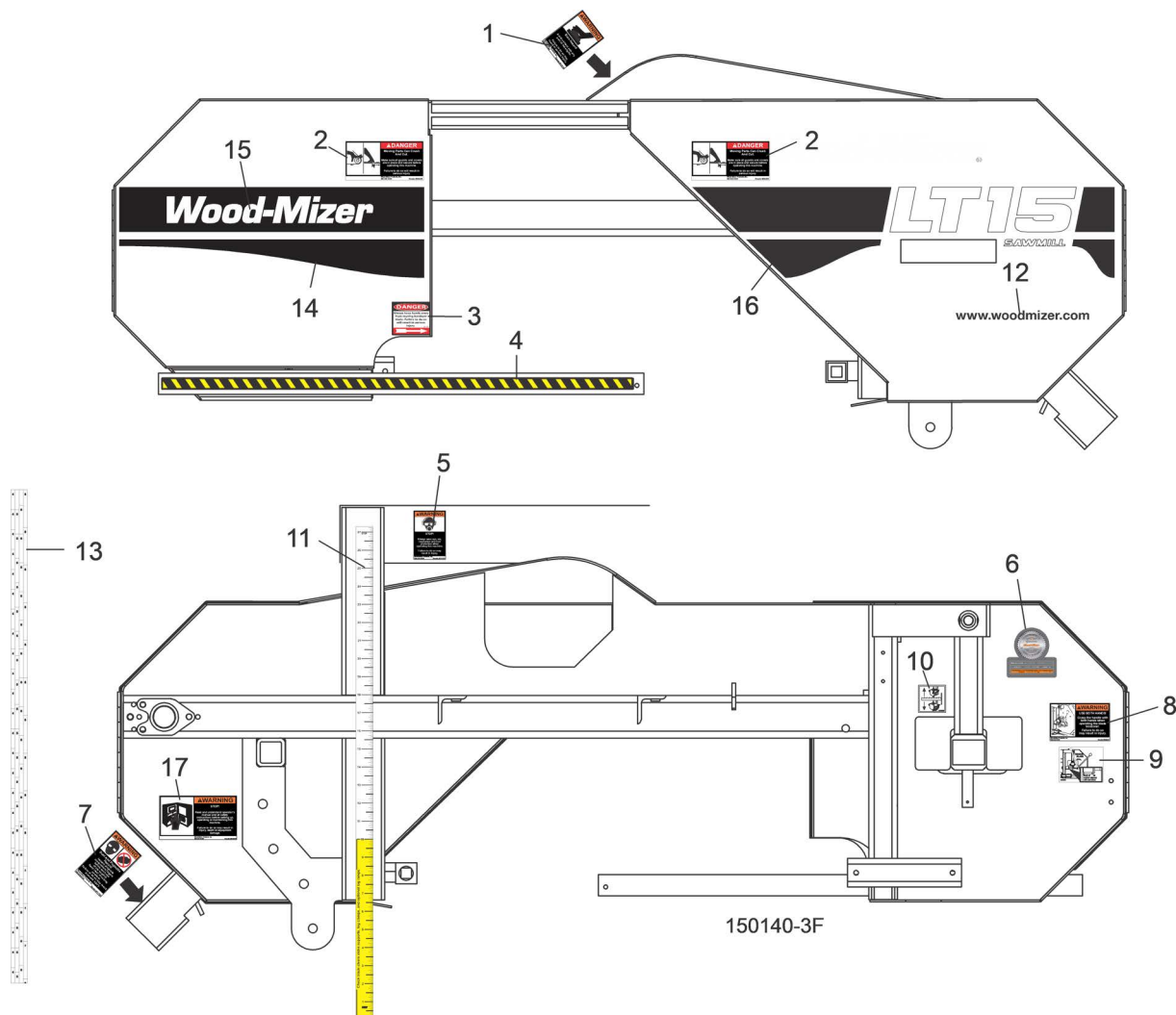

REF	PART #	DESCRIPTION	COMMENTS	QTY.
1	014419	DECAL, HOT ENGINE WARNING		1
2	033254	DECAL, MOVING PARTS DANGER		2
3	S11752	DECAL, BLADE DANGER W/ARROW		1
4	015849	DECAL, BLADE GUIDE ARM STRIPE		1
5	S11753	DECAL, EYE/EAR PROTECTION WARNING		1
6	079278	DECAL, WOOD-MIZER QUALITY & INFORMATION		1
7	P11754	DECAL, SAWDUST CHUTE WARNING		1
8	049367	DECAL, TENSIONER WARNING		1
9	049368	DECAL, BLADE TENSION INFO		1
10	P11789	DECAL, BLADE TRACK INFO		1
11	015784	DECAL, LT15 INCH SCALE		1
	076131	DECAL, LT15 WIDE INCH SCALE		1
12	003235	DECAL, WOOD-MIZER WEBSITE		1
13	016275	DECAL, MAGNETIC QUARTER SCALE		1
14	065008	DECAL, IDLE SIDE BLACK EURO STRIPE		1
15	065002	DECAL, WHITE WOOD-MIZER LOGO		1

REF	PART #	DESCRIPTION	COMMENTS	QTY.
16	011220-LT15	DECAL, LT15 DRIVE SIDE		1
	011220-LT15W	DECAL, LT15 WIDE DRIVE SIDE		1
	011220-LT15S	DECAL, LT15 START DRIVE SIDE		1
17	016402	DECAL, READ MANUAL WARNING		1

3.6 Blade Housing Covers & Wood Blocks

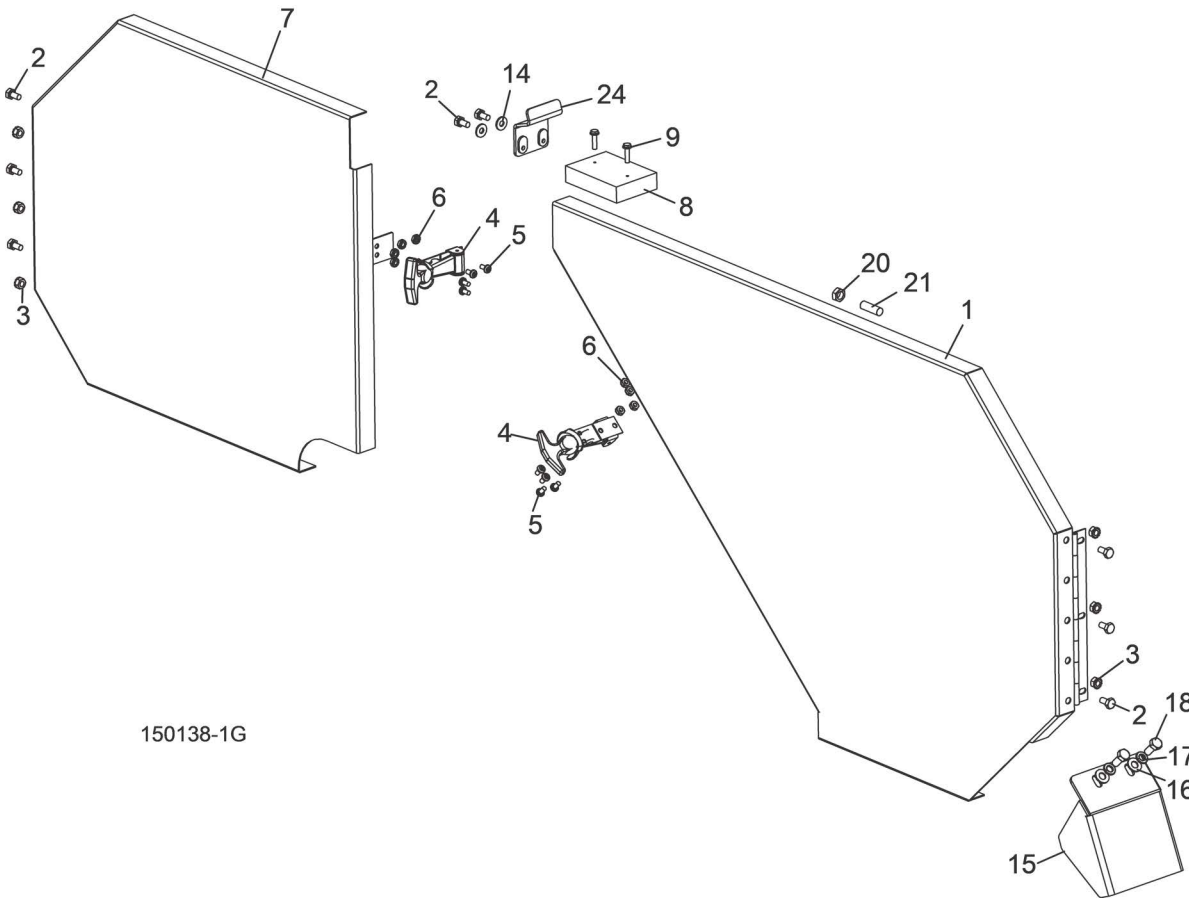
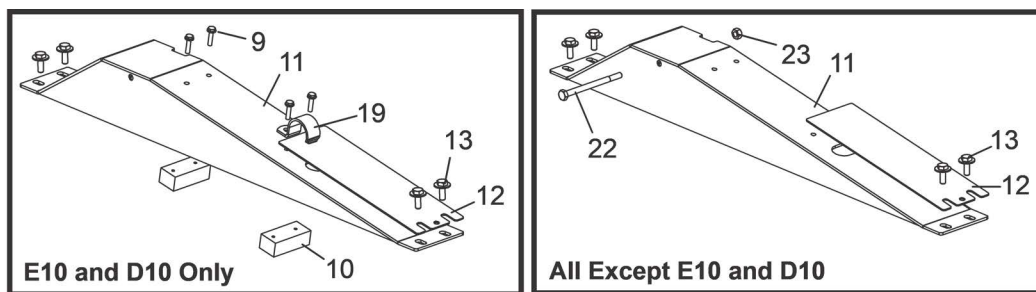

150138-1G

REF	PART #	DESCRIPTION	COMMENTS	QTY.
1	014984	COVER, DRIVE SIDE BLADE HOUSING	See Section 3.5	1
2	F05005-15	BOLT, 1/4-20 X 1/2" HEX HEAD		8
3	F05010-9	NUT, 1/4-20 KEPS		6
4	014829	LATCH, FLEXIBLE DRAW		2
5	F05004-3	SCREW, #10-24 X 3/8" CROSS SLOTTED ROUND HEAD		8
6	F05010-14	NUT, #10-24 SELF-LOCKING HEX		8
7	014985	COVER, IDLE SIDE BLADE HOUSING	See Section 3.5	1
8	015844	BLOCK, BLADE VIBRATION DAMPENING		1
9	F05015-33	BOLT, #10 X 3/4" SLOTTED HEX WASHER HEAD		6/2
10	016506	BLOCK, 3/4" X 1" X 2" WOOD (E10 AND D10 ONLY)		2
	038633	COVER ASSEMBLY, TOP ENGINE PULLEY		1

REF	PART #	DESCRIPTION	COMMENTS	QTY.
11	074574	Cover Weldment, LT15/28 Top Belt Cover		1
12	074546	Plate, Belt Guard Cover		1
13	F05005-134	Bolt, 1/4-20 x 3/4" Hex Head w/Conical Washer		4
14	F05011-11	WASHER, 1/4" SAE FLAT		2
15	003811	PLATE, SAWDUST DEFLECTOR		1
16	F05011-17	WASHER, 5/16" SAE FLAT		2
17	F05011-13	WASHER, 5/16" SPLIT LOCK		2
18	F05006-5	BOLT, 5/16-18 X 3/4" HEX HEAD		2
19	P05436	CLAMP, 1" EMT (E10 ONLY)		1
20	F05010-29	NUT, 3/8-16 JAM		1
21	F05007-18	SCREW, 3/8-16 X 1 1/4 SHOP SET		1
22	F05005-54	SCREW, 1/4-20 X 3 1/2" HEX HEAD (ALL EXCEPT E10 AND D10)		1
23	F05010-21	NUT, 1/4-20 SWAGED (ALL EXCEPT E10 AND D10)		1
24	074394	BRACKET WELDMENT, LT15 BELT ENHANCE		1

SECTION 4 UP/DOWN SYSTEM

4.1 Saw Head Mount

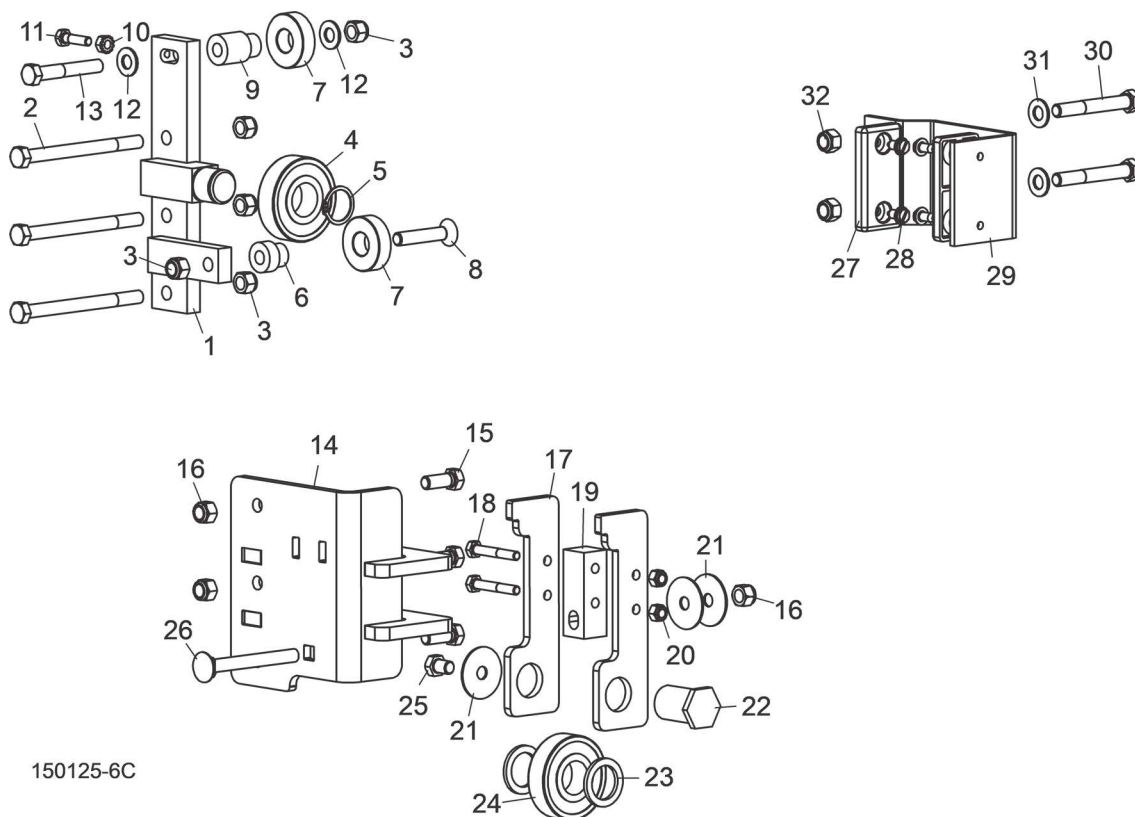

150125-6C

REF	PART #	DESCRIPTION	COMMENTS	QTY.
	046885	BEARING ASSEMBLY, SAW HEAD MOUNT UPPER		1
1	046635	Bracket Weldment, Upper Saw Head Mount		1
2	F05007-35	Bolt, 3/8-16 x 4 1/2" Hex Head		3
3	F05010-10	Nut, 3/8-16 Hex Nylon Lock		5
4	P08066	Bearing, .9843" x 2.4409" x .6693"		1
5	F04254-26	Ring, 25mm 5100-98 OR		1
6	046608	Bushing, Saw Head Mount Bearing		1
7	P06030-2	Bearing, 6203-2NSL 17mm SRI-2 ABEC-1		2
8	F05007-198	Bolt, 3/8-16 x 2" Flat Socket Head		1
9	074748	Spacer, Bearing		1
10	F05010-9	Nut, 1/4-20 Keps		2
11	F05005-101	Bolt, 1/4-20 x 1" Hex Head Grade 5		1
12	F05011-3	Washer, 3/8" SAE Flat		2
13	F05007-125	Bolt, 3/8-16 x 2 1/2" Hex Head Grade 5		1
	046886	BEARING ASSEMBLY, SAW HEAD MOUNT LOWER		1
14	046969	Bracket Weldment, Lower Saw Head Mount		1
15	F05007-87	Bolt, 3/8-16 x 1" Hex Head Grade 5		3
16	F05010-10	Nut, 3/8-16 Hex Nylon Lock		4
17	046604	Plate, Bearing Cam		2
18	046607	Block, Bearing Spacer		1

REF	PART #	DESCRIPTION	COMMENTS	QTY.
19	F05005-68	Bolt, 1/4-20 x 1 3/4" Hex Head Grade 5		2
20	F05010-69	Nut, 1/40-20 Hex Nylon Lock		2
21	F05011-44	Washer, 3/8" Fender		3
22	046606	Shaft, Bearing Mount		1
23	046974	Washer, Spacer		2
24	P08066	Bearing, .9843" x 2.4409" x .6693"		1
25	F05004-124	Bolt, 3/8-16 x 1/2" Hex Head Grade 5		1
26	F05007-161	Bolt, 3/8-16 x 3 1/2" Carriage Head		1
27	P13576	PAD, IDLE SIDE SLIDE		2
28	F05015-1	BOLT, 1/4-20 X 1/2" SLOTTED HEX HEAD		4
29	014905	BRACKET, IDLE SIDE SLIDE PAD MOUNT		1
30	F05007-29	BOLT, 3/8-16 X 2 3/4" HEX HEAD		2
31	F05011-3	WASHER, 3/8" SAE FLAT		2
32	F05010-10	NUT, 3/8-16 HEX NYLON LOCK		2

4.2 Up/Down Reducer Assembly (Optional)

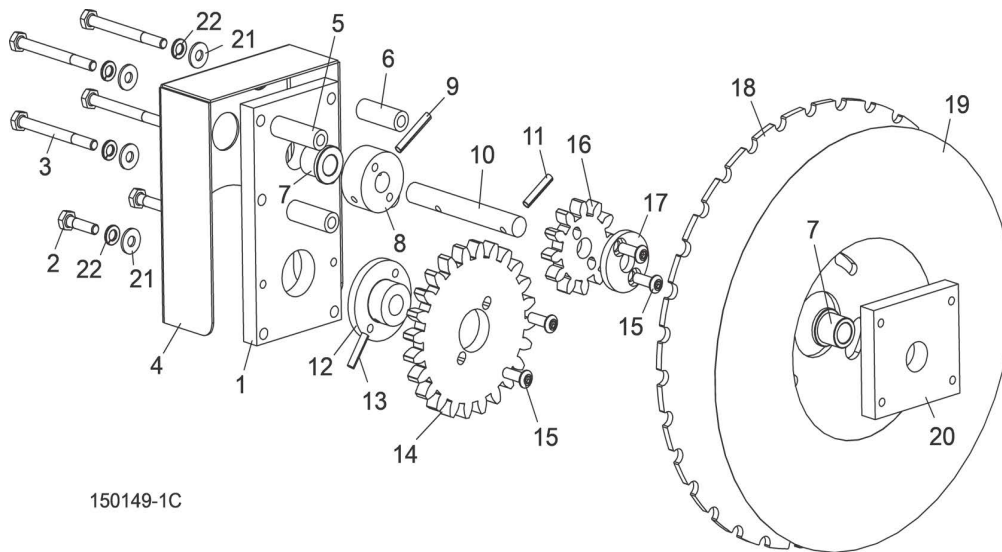

REF	PART #	DESCRIPTION	COMMENTS	QTY.
	038871	REDUCER KIT, LT15 UP/DOWN	Included with D18/D19 or G25 engines	1
1	049371	Plate, Rear Up/Down Reducer		1
2	F05005-101	Bolt, 1/4-20 x 1" Hex Head Grade 5		2
3	F05005-18	Bolt, 1/4-20 x 2 3/4" Hex Head		4
4	054610	Guard, Gear Reducer		1
5	049376	Spacer, Plate Mount Long		2
6	054587	Spacer, Plate Mount		2
7	P22317	Bushing, Flanged Bronze		2
8	049394	Spacer, Small Sprocket		1
9	F05012-16	Pin, 3/16" x 1 1/4" Roll		1
10	049377	Shaft, Up/Down Reducer		1
11	F05012-11	Pin, 3/16" x 1" Roll		1
12	049373	Bushing, Gear Mount		1
13	F05012-19	Pin, 3/16" x 7/8" Roll		1
14	049374	Sprocket, 12T Up/Down Reducer Large		3
15	F05005-60	Screw, 1/4-20 x 3/4" Socket Button Head		4
16	049375	Sprocket, 12T Up/Down Reducer Small		3
17	054589	Plate, Small Sprocket Lock		1
18	049395	Plate, 2:1 Up/Down Dial		1
19	054588	Decal, 2:1 Up/Down Dial		1
20	049372	Plate, Front Up/Down Reducer		1
21	F05011-11	Washer, 1/4" SAE Flat		6
22	F05011-14	Washer, 1/4" Split Lock		6

4.3 Manual Crank Assembly

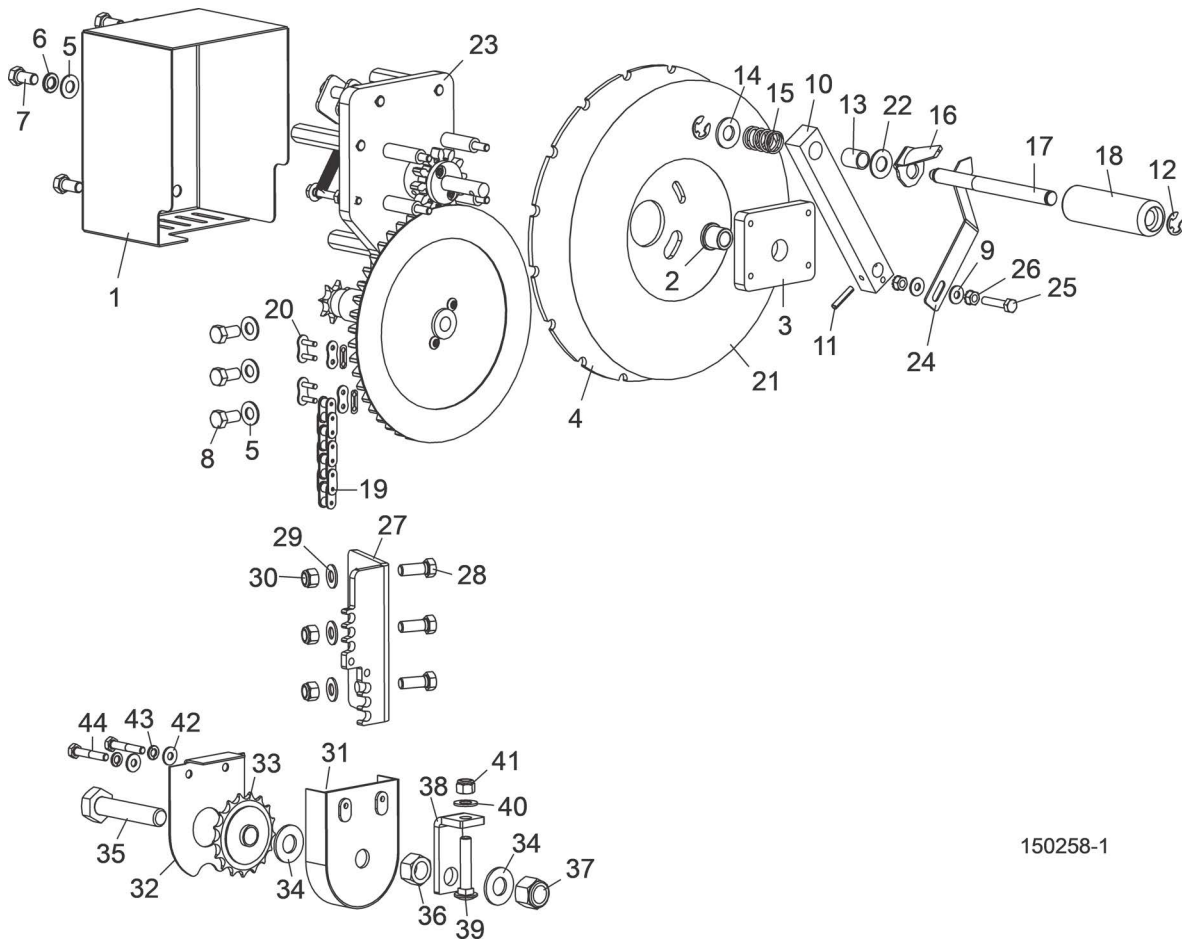

150258-1

REF	PART #	DESCRIPTION	COMMENTS	QTY.
	110068	ASSEMBLY, 4:1 GEAR REDUCED LT15		1
1	110171	Plate, 4:1 Up/Dn Lock		1
2	P22317	Bushing, 1/2x3/4 Bronze Flanged		1
3	110072	Plate, 4:1 Front Up/Dn Reducer		1
4	110071	Plate, Up/Down Lock		1
5	F05011-3	Washer, 3/8" SAE Flat		7
6	F05011-4	Washer, 3/8 Split Lock		4
7	F05007-27	Bolt, 3/8-16x3/4 Hex Head Grade 2		4
8	F05007-118	Bolt, 3/8-16 x 3/4" Hex Head Grade 5		3
9	F05011-11	Washer, 1/4 SAE Flat		2
10	046627	Block, LT15 Up/Down Handle		1
11	F05012-11	Pin, 3/16" x 1" Roll		1
12	P10649	Ring, 1/2" E-Clip Retaining		2
13	046976	Bushing, 1/2" x 5/8" x 3/4" Bronze		1
14	F05011-2	Washer, 1/2" SAE Flat		1
15	046975	Spring, .72" x .576" x 1.25" Compression		1
16	046867	Plate, Handle Lock Release		1
17	046644	Shaft, Up/Down Handle		1
18	046647	Handle, 33/64" x 1 1/4" x 4" Plastic		1
19	046983	Chain, #40 x 82 5/8" Roller		1
20	P04200	Link, #40 Master		2

REF	PART #	DESCRIPTION	COMMENTS	QTY.
21	110157	Decal, 4:1 Gear Reduced Blade Height		1
22	036597	Bearing, 1/2" ID x 1" OD x 1/16" Bronze Thrust		1
23	N/A	Manual Crank Mount & Sprocket Parts		1
24	048598	Plate, Pointer Up/Down		1
25	F05005-3	Bolt, 1/4-20 x 1 1/4" Hex Head Full Thread Cap		1
26	F05010-9	Nut, 1/4-20 Keps		2
27	076108	BRACKET, UP/DOWN CHAIN MOUNT		1
28	F05007-87	BOLT, 3/8-16 X 1" HEX HEAD GRADE 5'		3
29	F05011-3	WASHER, 3/8" SAE FLAT		3
30	F05010-10	NUT, 3/8-16 HEX NYLON LOCK		3
	046980	IDLER ASSEMBLY, LT15 LOWER UP/DOWN		1
31	015860	Guard Weldment, Chain Tension Sprocket		1
32	015859	Cover, Chain Tension Sprocket Guard		1
33	P04333	Sprocket, #40 Idler 17T 5/8" ID		1
34	F05011-5	Washer, 5/8" SAE Flat		1
35	F05009-1	Bolt, 5/8-11 x 3" Hex Head Full Thread		1
36	F05010-5	Nut, 5/8-11 Hex		1
37	F05010-34	Nut, 5/8-11 Hex Nylon Lock		1
38	046981	Bracket, LT15 Up/Down Chain Tensioner		1
39	F05007-22	Bolt, 3/8-16 x 2" Carriage Head Full Thread		1
40	F05011-3	Washer, 3/8" SAE Flat		1
41	F05010-10	Nut, 3/8-16 Hex Nylon Lock		1
42	F05011-11	Washer, 1/4" SAE Flat		2
43	F05011-14	Washer, 1/4" Split Lock		2
44	F05005-124	Bolt, 1/4-20 x 1 1/2" Hex Head		2

4.4 Manual Crank Mount & Sprocket Parts

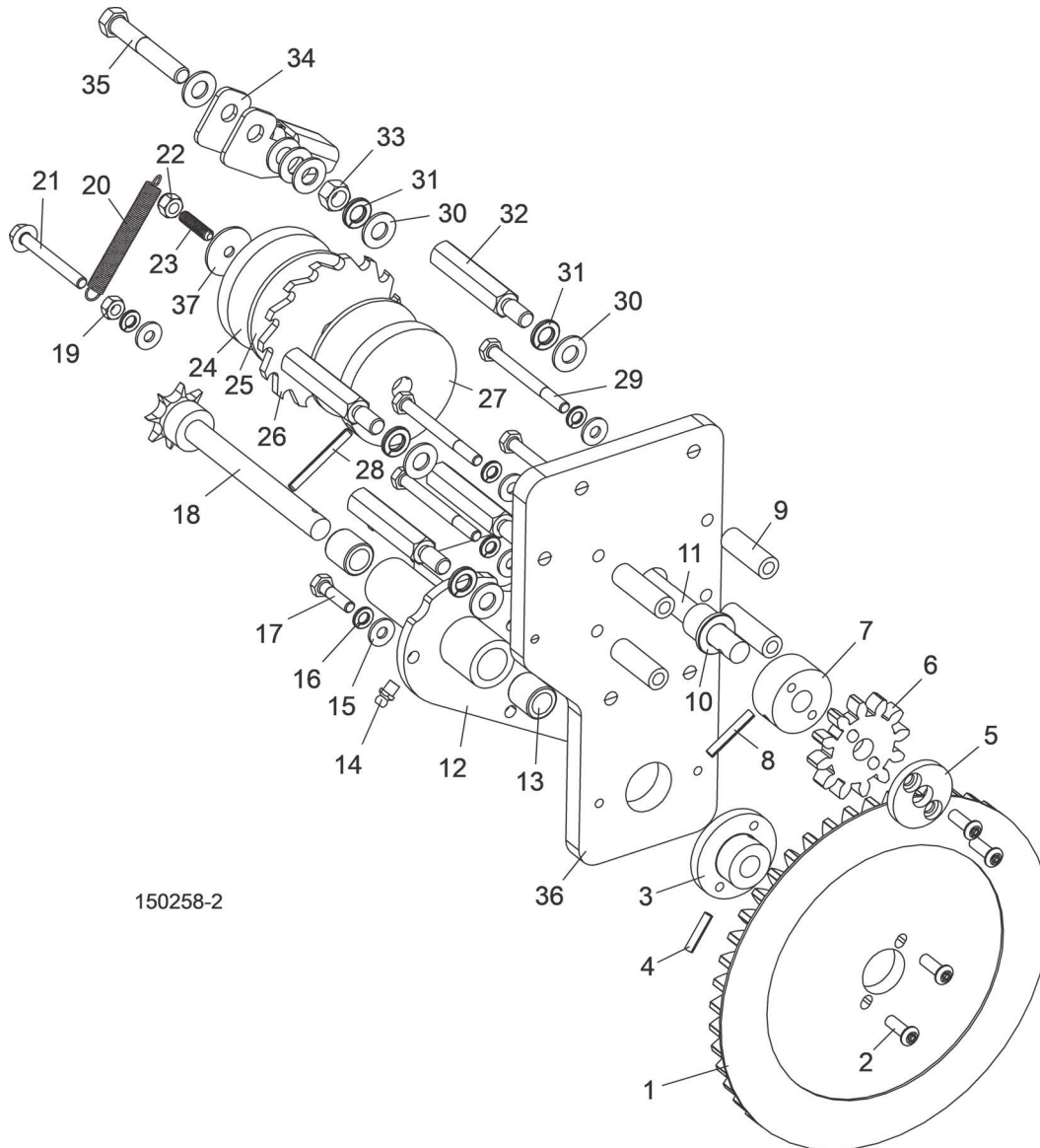

150258-2

REF	PART #	DESCRIPTION	COMMENTS	QTY.
1	110172	WELDMENT, 48T GEAR PLATE		1
2	F05005-60	SCREW, 1/4-20X3/4 SBHC		4
3	049373	BUSHING, GEAR MOUNT		1
4	F05012-19	PIN, 3/16X7/8 ROLL		1
5	054589	SPACER, SMALL GEAR LOCK		1
6	074940	GEAR, 12T UP/DN		1
7	049394	SPACER, SMALL GEAR		1
8	F05012-16	PIN, 3/16X1 1/4 ROLL		1
9	049376	SPACER, PLATE MOUNT LONG		1
10	P22317	BUSHING, 1/2X3/4 BRONZE FLANGED		1
11	110097	SHAFT, GEAR REDUCED UP/DN LONG		1
12	038649	UP/DN WELDMENT, LT15		1
13	049331	BEARING, NEEDLE ROLLER 1/2X3/4X3/4		2
14	P05060	FITTING, 1/4-28 GREASE		1
15	F05011-11	WASHER, 1/4 SAE FLAT		9

REF	PART #	DESCRIPTION	COMMENTS	QTY.
16	F05011-14	WASHER, 1/4 SPLIT LOCK		7
17	F05005-101	BOLT, 1/4-20X1 HH GR5		2
18	046648	SHAFT WELDMENT, LT15 UP/DN		1
19	F05010-63	NUT, 1/4-20 FREE ZINC		1
20	014818	SPRING, EXTENSION 3/8X3		1
21	F05005-180	SCREW, 1/4-20X2 1/4 FT ZNC PL FLANGE CAP		1
22	F05010-69	NUT, 1/4-20 NYLOCK		1
23	F05005-217	SCREW, 1/4-20X1 NYL PATCH SH FLAT PT SET		1
24	110100	PLATE, UP/DN RATCHET WASHER		1
25	110149	PAD, UP/DN FRICTION		2
26	110099	PLATE, UP/DN RATCHET		1
27	110098	WASHER, UP/DN CLUTCH		1
28	F05012-103	PIN, 3/16X1 3/4 ROLL ZINC		1
29	F05005-18	BOLT, 1/4-20X2 3/4 HH GR5		4
30	F05011-3	WASHER, 3/8 FLAT SAE		9
31	F05011-4	WASHER, 3/8 SPLIT LOCK		5
32	015136	SPACER, POWER FEED MOTOR		4
33	F05010-1	NUT, 3/8-16 HEX		1
34	110148	PLATE, UP/DN RATCHET LOCK		1
35	F05007-125	BOLT, 3/8-16X2 1/2 HH GR5		1
36	110067	PLATE, 4:1 REAR UP/DN REDUCER		1
37	F05011-12	WASHER, 1/4 FENDER		1

SECTION 5 FEED SYSTEM & TRACK ROLLERS

5.1 Track Rail, Rollers, & Travel Pins

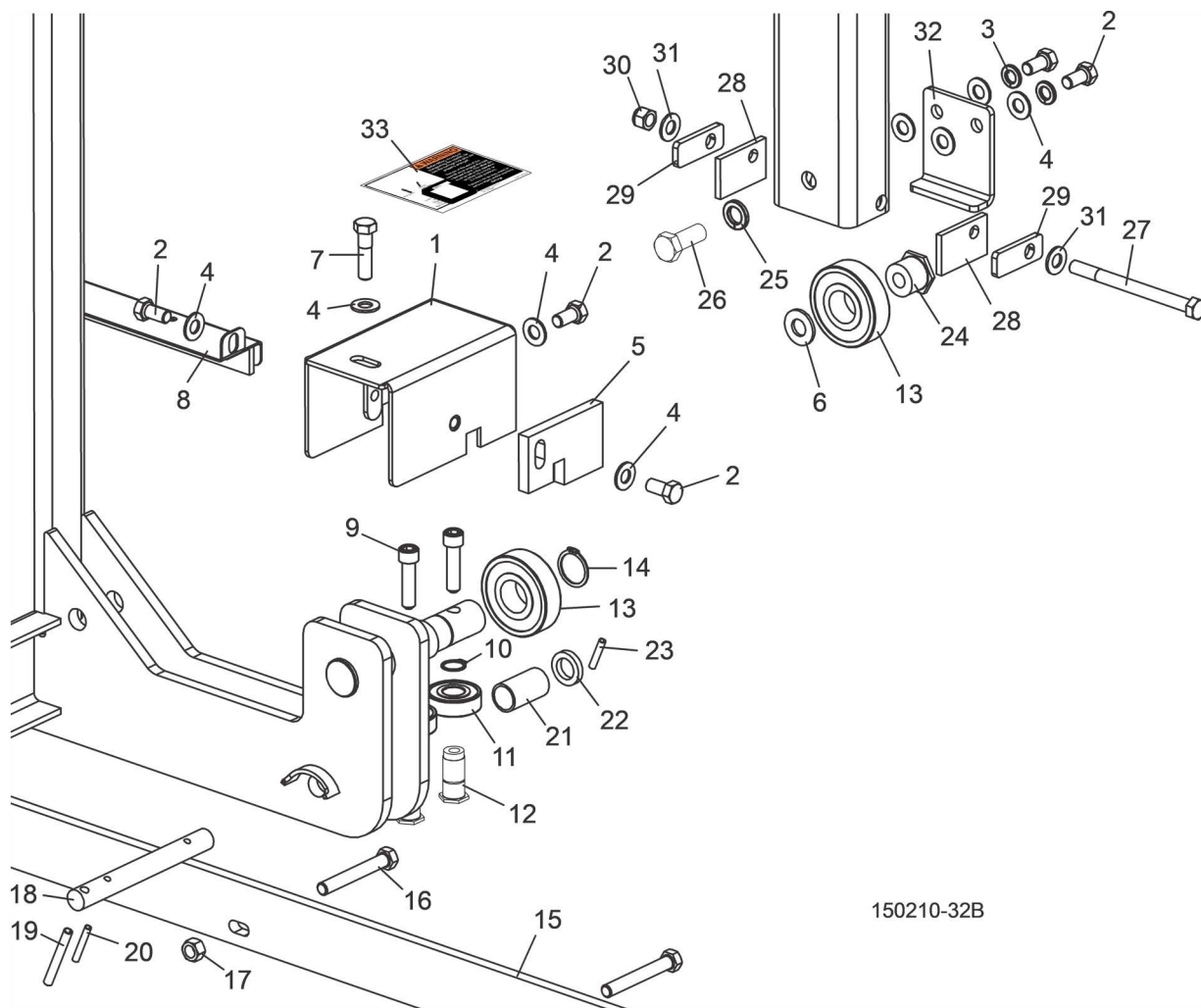

150210-32B

REF	PART #	DESCRIPTION	COMMENTS	QTY.
1	015846	COVER WELDMENT, TRACK ROLLER		2
2	F05007-27	BOLT, 3/8-16 X 3/4" HEX HEAD		6
3	F05011-4	WASHER, 3/8" SPLIT LOCK		2
4	F05011-3	WASHER, 3/8" SAE FLAT		6
5	014906	PLATE, TRACK WIPER		2
6	F05011-2	WASHER, 1/2" SAE FLAT		1
7	F05007-78	BOLT, 3/8-16 X 1 1/2" HEX HEAD		2
8	110818	COVER, MIDDLE TRACK WITH FELT	(See Section 5.2)	1
9	F05007-36	BOLT, 3/8-16 X 1 1/2" SOCKET HEAD		4
10	F04254-2	RING, 5/8" (5100-62) OUTER RETAINING		4
11	P06030-1	BEARING, 5/8" X 1.75" X .47"		4
12	110404	SHAFT, ROLLER UPRIGHT		4
13	P08066	BEARING, .98" X 2.44" X .67"		3
14	F04254-26	RING, 25MM (5100-98) OUTER RETAINING		2

5 Feed System & Track Rollers

Track Rail, Rollers, & Travel Pins

REF	PART #	DESCRIPTION	COMMENTS	QTY.
15	016489	RAIL, PINNED 80.5" LONG BED		2
16	F05007-230	BOLT, 3/8-16 X 2 3/4" HEX HEAD FULL THREAD		24
17	F05010-25	NUT, 3/8-16 HEX LOCK		24
18	014899	PIN, TRAVEL LOCK		2
19	F05012-46	PIN, 1/4" X 2" ROLL		2
20	F05012-16	PIN, 3/16" X 1 1/4" ROLL		2
21	P07997	SPRING, 7/8" O.D. X 1 1/2" COMPRESSION		2
22	S12480	WASHER, 41/64" ID X 1" OD X 3/16" THICK		2
23	F05012-11	PIN, 3/16" X 1" ROLL		2
24	014974	SHAFT, IDLE SIDE ROLLER MOUNT		1
25	F05011-9	WASHER, 1/2" SPLIT LOCK		1
26	F05008-37	BOLT, 1/2-13 X 1 1/4" HEX HEAD GRADE 5		1
	074251	BRACKET ASSEMBLY, IDLE WIPER		1
27	F05007-35	Bolt, 3/8-16 x 4 1/2" Hex Head Grade 5		1
28	074270	Felt, Idle Wiper		2
29	074250	Bracket, Left Idle Wiper		2
30	F05010-10	Nut, 3/8-16 Hex Nylon Lock		1
31	F05011-3	Washer, 3/8" SAE Flat		2
32	014897	PLATE, IDLE SIDE GUIDE		1
33	017926	DECAL, LOCK PIN WARNING		2

5.2 Rail Wiper

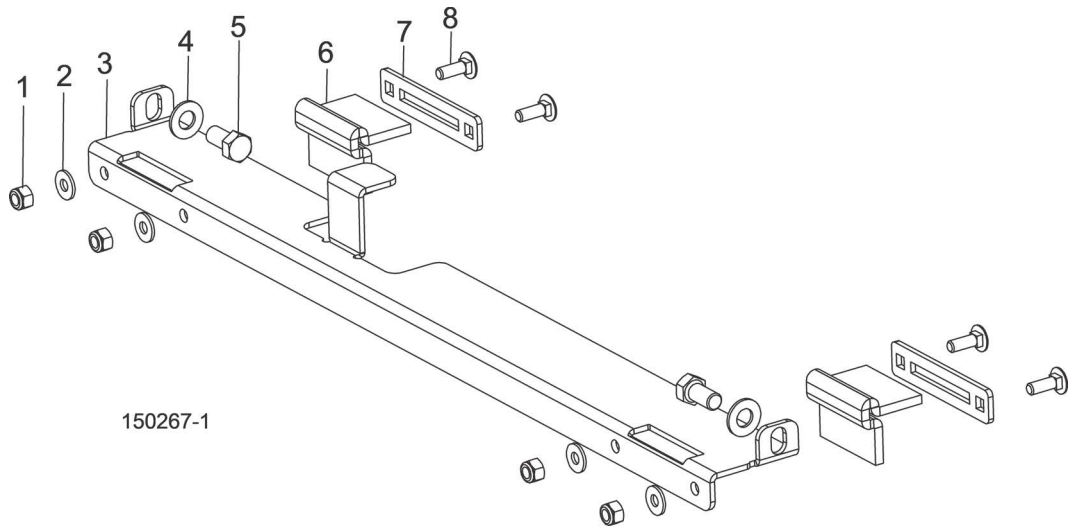

REF	PART #	DESCRIPTION	COMMENTS	QTY.
	110818	Cover Assy, Middle Track		1
	110819	Cover Assy, Middle Track Idle LT15 Wide		1
1	F05010-69	Nut, 1/4-20 Nylock		4
2	F05011-11	Washer, 1/4 SAE Flat		4
3	110815	Cover, LT15 Middle Track	Use with 110818	1
	110816	Cover, LT15 Middle Track	Use with 110819	1
4	F05011-3	Washer, 3/8 Flat SAE		2
5	F05007-27	Bolt, 3/8-16x3/4 HH Gr2		2
6	110820	Felt, LT15 Track Wiper		2
7	110783	Retainer, Felt Oiler		2
8	F05005-113	Bolt, 1/4-20x3/4 Carriage		4

5.3 Feed Stop Brackets

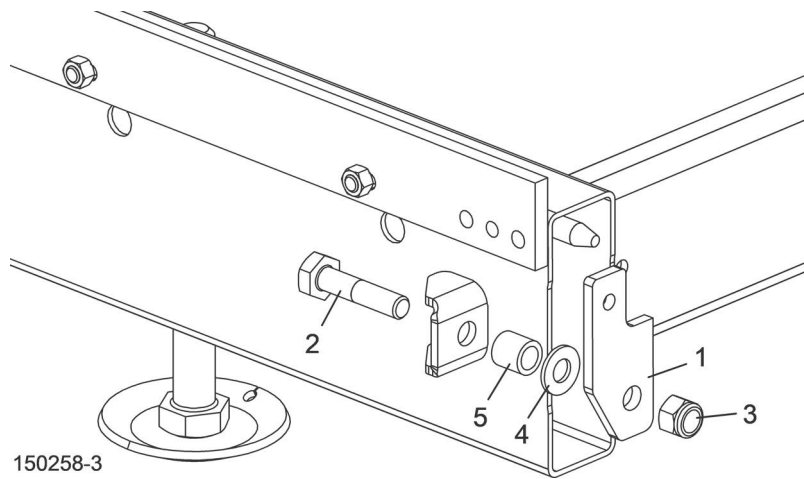

REF	PART #	DESCRIPTION	COMMENTS	QTY.
1	076625	BRACKET, ROPE/STOP		2
2	F05008-10	BOLT, 1/2-13 X 2 1/4" HEX HEAD GRADE 5		2
3	F05010-8	NUT, 1/2-13 HEX NYLON LOCK		2
4	F05011-2	WASHER, 1/2" SAE FLAT		2
5	033911	SPACER, FEED MOUNT BRACKET		2

5.4 Manual Push Handle

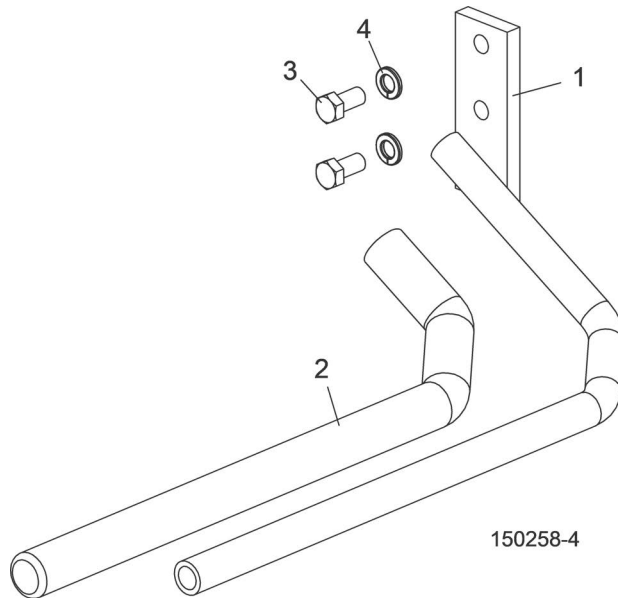

REF	PART #	DESCRIPTION	COMMENTS	QTY.
	110054	HANDLE ASSEMBLY, LT15G14 START PUSH		1
1	046857	Handle Weldment, LT15 Push		1
2	028390	Grip, Handle		1
3	F05007-118	Bolt, 3/8-16x3/4 Hex Head Grade 5		2
4	F05011-4	Washer, 3/8 Split Lock		2

SECTION 6 BED FRAME ASSEMBLY

6.1 Log Wedge, Loading Ramps, & Cant Hook (Optional)

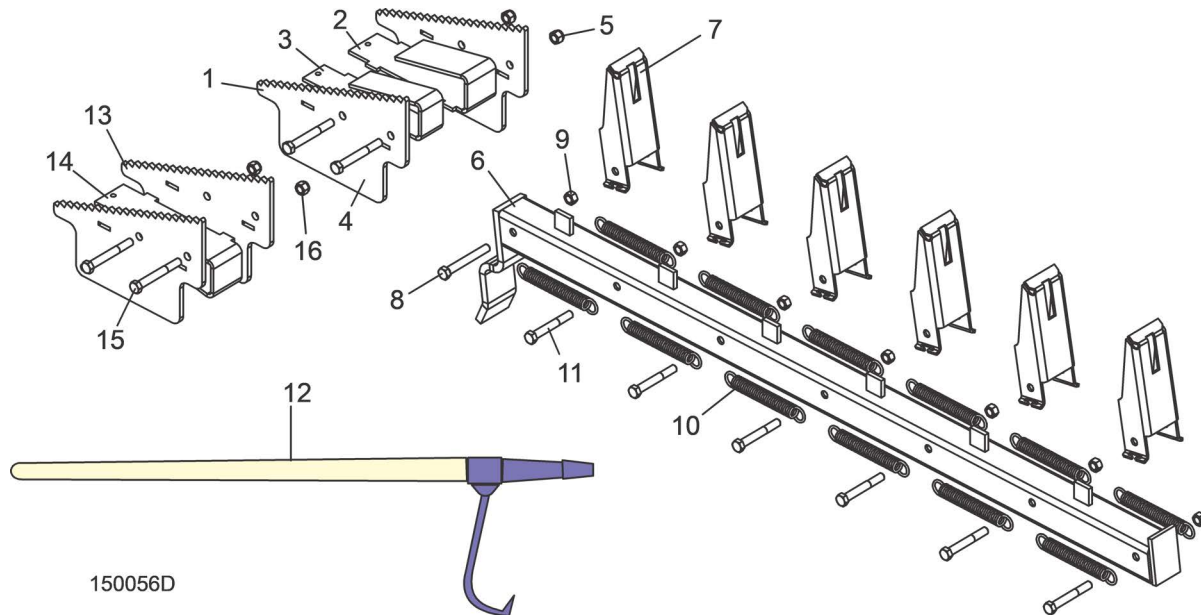

REF	PART #	DESCRIPTION	COMMENTS	QTY.
	LT15OP	KIT, OPTIONAL PACKAGE LT15		
	015809	WEDGE ASSY, LOG TAPER		1
1	015807	Plate, LT15 Wedge	Available in assemblies only.	2
2	007073	Bracket, LT15 Wedge (LT15BS Rev. G.00+)	Available in assemblies only.	1
3	015808	Bracket, LT15 Wedge Bed Spacer (LT15BS Rev. A.00 - F.00)	Available in assemblies only.	1
4	F05007-73	Bolt, 3/8-16 x 3" Hex Head Grade 5		2
5	F05010-10	Nut, 3/8-16 Hex Nylon Lock		2
	015804	RAMP ASSY, LOG LOADING		2
6	015803	Ramp Weldment, Log Loading	Available in assemblies only.	1
7	S08329	Bracket, Log Loading Stop		6
8	F05007-1	Bolt, 3/8-16 x 3" Hex Head Full Thread		1
9	F05010-10	Nut, 3/8-16 Hex Nylon Lock		7
10	P04060	Spring, .563" O.D. x .072" x 5" Extension		12
11	F05007-29	Bolt, 3/8-16 x 2 3/4" Hex Head		6
12	CH048	HOOK, ALUMINUM HANDLE CANT		1
	CH	HOOK, WOOD HANDLE CANT	Not shown	1
	074403	WEDGE ASSEMBLY, LOG TAPER LT15 WIDE	Included with LT15 Wide	1
13	015807	Plate, LT15 Wedge	Available in assemblies only.	2
14	007073	Bracket, LT15 Wedge (LT15BS Rev. G.00+)	Available in assemblies only.	1
15	F05007-73	Bolt, 3/8-16 x 3" Hex Head Grade 5		2
16	F05010-10	Nut, 3/8-16 Hex Nylon Lock		2

6.2 Bed Section & Connecting Hardware

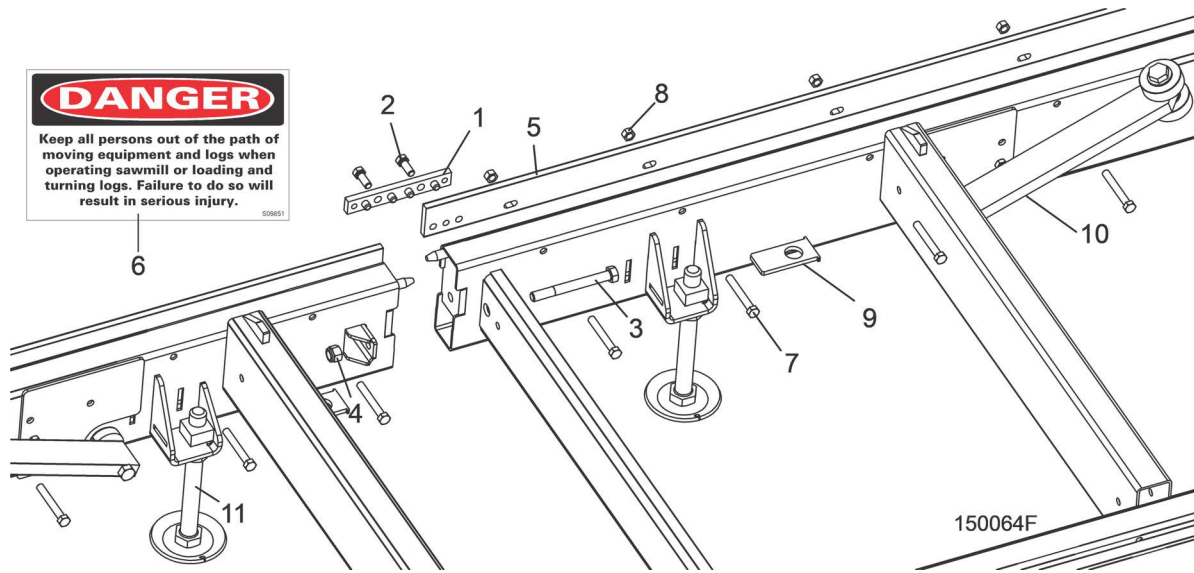

DANGER
Keep all persons out of the path of moving equipment and logs when operating sawmill or loading and turning logs. Failure to do so will result in serious injury.

REF	PART #	DESCRIPTION	COMMENTS	QTY.
	LT15BS	BED ASSEMBLY, 6'-8" LT15 EXTENSION	Note: LT15G25B2 includes Qty (2) LT15BS	3
1	016170	Splice Assembly, Pinned Bed Rail		1
2	F05007-87	Bolt, 3/8-16 X 1" Grade 5 Hex Head		2
3	F05008-66	Bolt, 1/2-13 X 5" Grade 5 Hex Head		4
4	F05010-8	Nut, 1/2-13 Hex Nylon Lock		4
5	016489	Rail, Pinned 80.5" Long Bed		1
6	S09851	Decal, Keep Away Danger		1
7	F05007-230	Bolt, 3/8-16 x 2 3/4" Hex Head Full Thread		8
8	F05010-25	Nut, 3/8-16 Swaged Lock		8
9	110790	Plate, Outrigger Nut		4
10	See Parts	Side Support Parts	(See Section 6.4)	1
11	See Parts	Leg Parts	(See Section 6.3)	4
	See Parts	Lock Pin Retrofit Parts	(See Section 5.1)	1

6.3 Leg Assembly

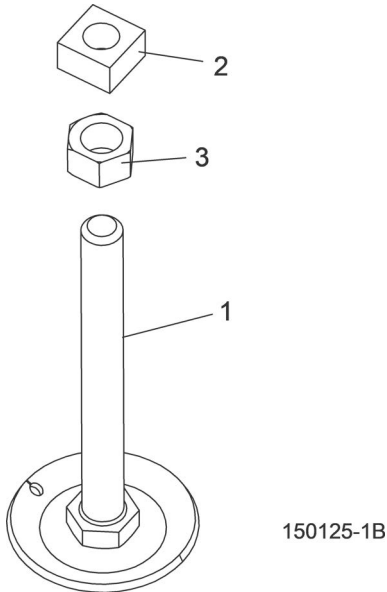

REF	PART #	DESCRIPTION	COMMENTS	QTY.
1	046615	LEG WELDMENT, LT15 2004		4
2	F05010-186	NUT, 7/8-9 SQUARE		4
3	F05010-136	NUT, 7/8-9 HEX		4

6.4 Log Side Support Assembly

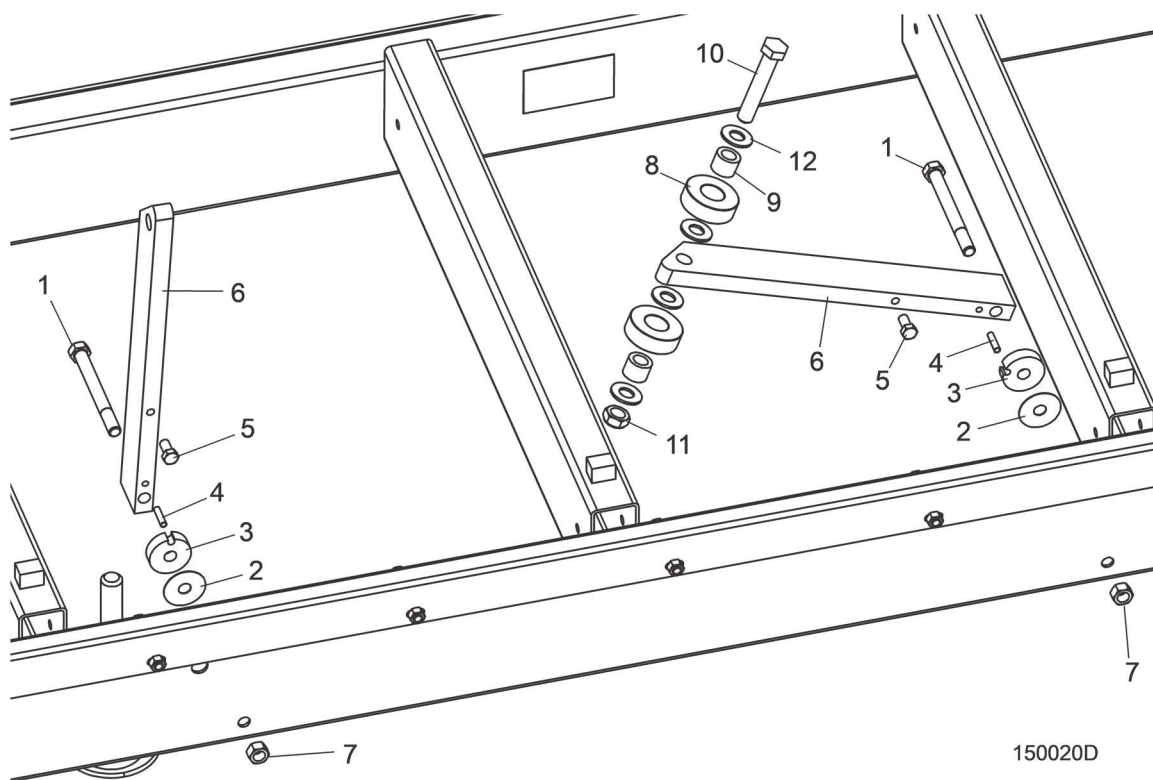

REF	PART #	DESCRIPTION	COMMENTS	QTY.
1	F05008-28	BOLT, 1/2-13 X 5 1/2" HEX HEAD CAP GRADE 5		2
2	014972	WASHER, 33/64 X 1 3/4 X 1/32" NYLON		2
3	025767	WASHER, 1/2" LOG SIDE SUPPORT		2
4	F05012-7	PIN, 1/4 X 1" ROLL		2
5	F05007-168	BOLT, 3/8-16 X 3/4" HEX HEAD GRADE 5 W/NYLON PATCH		2
6	014855	SUPPORT, LOG SIDE		2
7	F05010-3	NUT, 1/2-13 HEX LOCK		2
	074276	ROLLER ASSEMBLY, LT15 SIDE SUPPORT		1
8	016561	Roller, Side Support		2
9	016560	Bushing, Bronze 5/8" x 1" x 3/4"		2
10	F05009-93	Bolt, 5/8-11 x 3 1/2" Hex Head Grade 5		1
11	F05010-96	Nut, 5/8-11 Jam Nylon Lock		1
12	F05011-5	Washer, 5/8" SAE Flat		4

6.5 Log Clamp

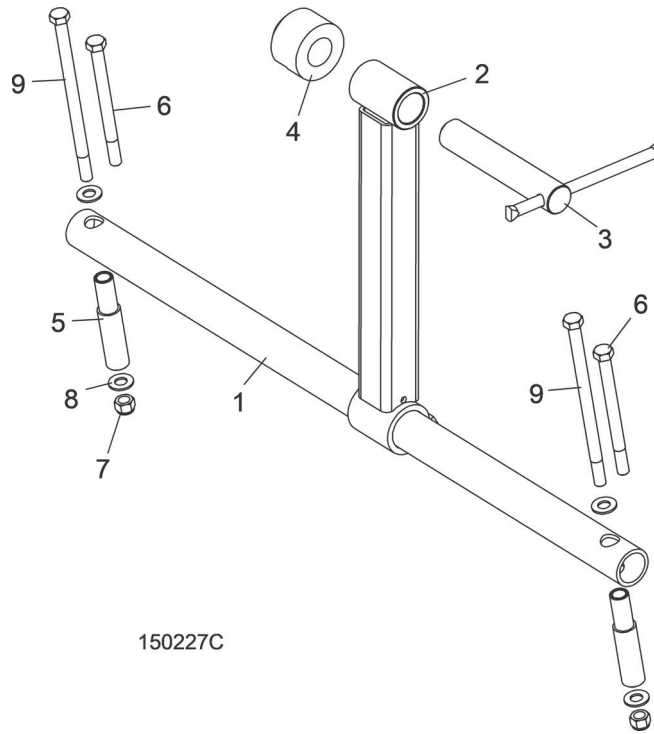

150227C

REF	PART #	DESCRIPTION	COMMENTS	QTY.
	065661	CLAMP ASSEMBLY, LT10/15 RETRO		1
	071347	Clamp Assembly, LT10/LT15 Log Pivoting	Available in assemblies only.	1
1	071026	Tube, 2012 Clamp Main		1
	061101	Clamp Kit, LT10/LT15		1
2	071343	Tube Weldment, Clamp Post	Available in assemblies only.	1
3	071350	Screw Assembly, Clamp		1
4	075295	Block, Clamp Point		1
5	071034	Spacer, 2012 Clamp Mount		2
6	F05007-109	Bolt, 3/8-16 x 4 3/4" Hex Head Grade 5	Not used for LT15	2
7	F05010-10	Nut, 3/8-16 Hex Nyloc		2
8	F05011-3	Washer, 3/8" Flat SAE		4
9	F05007-205	Bolt, 3/8-16 x 6 1/2" Hex Head Grade 5		2
	F05007-45	Screw, 3/8-16 x 6" Hex Head		2
	065661-1784	Instruction Sheet, LT10/15 Log Clamp		1

SECTION 7 MISCELLANEOUS

7.1 Replacement Manuals



REF	DESCRIPTION (◆ Indicates Parts Available In Assemblies Only)	PART #	QTY.
Wood-Mizer Product Information			
1	ALL-PRODUCTS CATALOG	PS750	1
Basic Sawmill Manuals			
2	TRU-SHARP BLADE HANDBOOK	M600	1
3	WOOD-MIZER GENERAL INFORMATION	M601	1
4	LT15 OPERATOR'S MANUAL	M2302	1
5	LT15 PARTS MANUAL	M2304	1
Power Option Manuals			
6	G14 ENGINE OPTION MANUAL	M2306	1
Miscellaneous Option Manuals			
7	SHINGLE/LAPSIDER OPTION MANUAL	M621	1
8	LATHE-MIZER OPTION MANUAL	M1337	1
9	LT15 POWER FEED OPTION MANUAL	M1539	1
10	LT15 LOAD ASSIST KIT OPTION MANUAL	M1540	1