

# Wood-Mizer<sup>®</sup> Sawmill

## Parts Manual

---

LT35HD

rev. A6.19

---

***Safety is our #1 concern!***

Form #1721

**California**  
Proposition 65 Warning



**WARNING:** Breathing gas/diesel engine exhaust exposes you to chemicals known to the State of California to cause cancer and birth defects or other reproductive harm.

Always start and operate the engine in a well-ventilated area.  
If in an enclosed area, vent the exhaust to the outside.  
Do not modify or tamper with the exhaust system.  
Do not idle the engine except as necessary.

For more information go to **[www.P65warnings.ca.gov](http://www.P65warnings.ca.gov)**.



**WARNING:** Drilling, sawing, sanding or machining wood products can expose you to wood dust, a substance known to the State of California to cause cancer. Avoid inhaling wood dust or use a dust mask or other safeguards for personal protection.

For more information go to **[www.P65Warnings.ca.gov/wood](http://www.P65Warnings.ca.gov/wood)**.

**Active Patents assigned to Wood-Mizer, LLC**

Wood-Mizer, LLC has received patents that protect our inventions which are a result of a dedication to research, innovation, development, and design. Learn more at: [woodmizer.com/patents](http://woodmizer.com/patents)

**©2024 Wood-Mizer LLC**

Printed in the United States of America, all rights reserved. No part of this manual may be reproduced in any form by any photographic, electronic, mechanical or other means or used in any information storage and retrieval system without written permission from

**Wood-Mizer, LLC**  
**8180 West 10th Street**  
**Indianapolis, Indiana 46214**

# Table of Contents

# Section-Page

<b>SECTION 1</b>	<b>REPLACEMENT PARTS</b>	<b>1-1</b>
1.1	How To Use The Parts List .....1-1 <i>To Order Parts</i>	
1.2	Sample Assembly .....1-1	
1.3	Torque Values .....1-2	
<b>SECTION 2</b>	<b>BLADE GUIDE ROLLERS &amp; ARM</b>	<b>2-1</b>
2.1	Blade Guide Assembly, Idle Side.....2-1	
2.2	Blade Guide Assembly, Drive Side.....2-3	
2.3	Blade Guide Arm.....2-5	
<b>SECTION 3</b>	<b>BLADE WHEELS &amp; TENSIONER</b>	<b>3-1</b>
3.1	Blade Drive Assembly.....3-1	
3.2	Idle Blade Wheel Assembly .....3-2	
3.3	Blade Tensioner Assembly .....3-3	
<b>SECTION 4</b>	<b>SAW HEAD</b>	<b>4-1</b>
4.1	Water Lube Assembly .....4-1	
4.2	Saw Head Decals.....4-3	
4.3	Blade Housing Covers.....4-4	
4.4	Sawdust Chute .....4-5	
<b>SECTION 5</b>	<b>CONTROL &amp; BATTERY BOXES</b>	<b>5-1</b>
5.1	Control Assembly .....5-1	
5.2	Drum Switches .....5-3	
5.3	Front Panel Assembly.....5-4	
5.4	Battery Box Assembly.....5-5	
<b>SECTION 6</b>	<b>UP/DOWN SYSTEM</b>	<b>6-1</b>
6.1	Saw Head Mount .....6-1	
6.2	Up/Down Assembly .....6-3	
6.3	Magnetic Position Sensor Assembly .....6-5	
<b>SECTION 7</b>	<b>FEED SYSTEM &amp; TRACK ROLLERS</b>	<b>7-1</b>
7.1	Track Rollers And Wipers.....7-1	
7.2	Power Feed Assembly .....7-3	
7.3	Feed Chain/Stop .....7-5	
<b>SECTION 8</b>	<b>BED FRAME ASSEMBLY</b>	<b>8-1</b>
8.1	Bed Rail Assembly, Front And Rear .....8-1	
8.2	Bed Rail Assembly, Middle Front.....8-2	
8.3	Bed Rail Assembly, Middle Rear .....8-3	
8.4	Pivot Bed Rail Assembly .....8-4	
8.5	Log Side Support Assembly (Manual) .....8-5	
8.6	Transport Safety Chain and Rest Pin.....8-6	

## Table of Contents

## Section-Page

8.7	Bed Frame Decals .....	8-7	
8.8	Board Outfeed Table (Optional) .....	8-8	
<b>SECTION 9</b>	<b>BED HYDRAULIC SYSTEM</b>		<b>9-1</b>
9.1	Hydraulic Hoses .....	9-1	
9.2	Hydraulic Control Box .....	9-2	
9.3	Hydraulic Power Supply Strip.....	9-5	
9.4	Hydraulic Log Loader .....	9-7	
9.5	Hydraulic Log Turner.....	9-9	
9.6	Hydraulic Log Side Supports .....	9-10	
9.7	Hydraulic Log Side Supports (Middle - Optional) .....	9-12	
9.8	Hydraulic Log Clamp .....	9-13	
9.9	Hydraulic Toe Board .....	9-15	
<b>SECTION 10</b>	<b>MISCELLANEOUS</b>		<b>10-1</b>
10.1	Replacement Manuals .....	10-1	

## SECTION 1 REPLACEMENT PARTS

### 1.1 How To Use The Parts List

- Use the table of contents to locate the assembly that contains the part you need.
- Go to the appropriate section and locate the part in the illustration.
- Use the number pointing to the part to locate the correct part number and description in the table.
- Parts shown indented under another part are included with that part.

#### *To Order Parts*

- From the continental US, call **1-800-525-8100** to order parts. Have your customer number, vehicle identification number, and part numbers ready when you call.
- From other international locations, contact the Wood-Mizer distributor in your area for parts.

### 1.2 Sample Assembly



REF	PART #	DESCRIPTION	COMMENTS	QTY.
	012345	SAMPLE ASSEMBLY, COMPLETE	INCLUDES ITEMS 1-6	1
1	F02222-22	Sample Part		1
2	F03333-33	Sample Part		2
	098765	Sample Subassembly	Includes items 3-6	1
3	S04444-44	Subassembly Sample Part		1
4	K55555	Subassembly Sample Part		1
	054321	Sample Sub-Subassembly	Includes items 5-6	2
5	022222	Sub-Subassembly Sample Part		1
6	F10234-56	Sub-Subassembly Sample Part		1

The Sample Assembly, Complete, part number 02345 (top level assembly) includes two parts (F0222-22 and F0333-33) and the 098765 subassembly.

Subassembly 098765 contains two parts(S04444-44 and K55555) and two copies of sub-subassembly 054321.

Each sub-subassembly 054321 contains two parts (022222 and F10234-56).

### 1.3 Torque Values

Grade		Units	SAE 5	SAE 8
Grade Mark				
Bolt Dia.	Threads Per In.	Units	SAE 5	SAE 8
6	32	in-lbs (Nm)	20 (2.3)	-
8	32	in-lbs (Nm)	24 (2.7)	30 (3.4)
10	24	in-lbs (Nm)	35 (4.0)	45 (5.1)
10	32	in-lbs (Nm)	40 (4.5)	50 (5.7)
12	24	in-lbs (Nm)	50 (5.7)	65 (7.3)
1/4	20	in-lbs (Nm)	95 (10.7)	125 (14.1)
1/4	28	in-lbs (Nm)	95 (10.7)	150 (17.0)
5/16	18	ft-lbs (Nm)	17 (22.6)	23 (31.2)
5/16	24	ft-lbs (Nm)	20 (27.1)	25 (33.8)
3/8	16	ft-lbs (Nm)	30 (40.7)	40 (54.2)
3/8	24	ft-lbs (Nm)	35 (47.5)	45 (61.0)
7/16	14	ft-lbs (Nm)	50 (67.8)	65 (88.1)
7/16	20	ft-lbs (Nm)	55 (74.6)	70 (94.9)
1/2	13	ft-lbs (Nm)	75 (101.7)	100 (135.6)
1/2	20	ft-lbs (Nm)	85 (115.3)	110 (149.2)
9/16	12	ft-lbs (Nm)	105 (142.4)	135 (183.1)
9/16	18	ft-lbs (Nm)	115 (155.9)	150 (203.4)
5/8	11	ft-lbs (Nm)	150 (203.4)	195 (264.4)
5/8	18	ft-lbs (Nm)	160 (217.0)	210 (284.8)
3/4	10	ft-lbs (Nm)	170 (230.5)	220 (298.3)
3/4	16	ft-lbs (Nm)	175 (237.3)	225 (305.1)
7/8	9	ft-lbs (Nm)	302 (409.5)	473 (640.9)
7/8	14	ft-lbs (Nm)	300 (406.8)	400 (542.4)
1	8	ft-lbs (Nm)	466 (631.8)	714 (967.4)

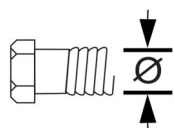

Metric Bolt Head Identification



**8.8**  
Metric Grade 8.8



**10.9**  
Metric Grade 10.9

COARSE THREAD					FINE THREAD				Wrench Size	
Diameter & Thread Pitch	Metric 8.8		Metric 10.9		Diameter & Thread Pitch	Metric 8.8		Metric 10.9		
	N-m	lbs-ft	N-m	lbs-ft		N-m	lbs-ft	N-m		lbs-ft
6 x 1.0	8	6	11	8					10 mm	
8 x 1.25	20	15	27	20	8 x 1.0	21	16	29	22	13 mm
10 x 1.5	39	29	54	40	10 x 1.25	41	30	57	42	16 mm
12 x 1.75	68	50	94	70	12 x 1.25	75	55	103	76	18 mm
14 x 2.0	109	80	151	111	14 x 1.5	118	87	163	120	21 mm
16 x 2.0	169	125	234	173	16 x 1.5	181	133	250	184	24 mm
18 x 2.5	234	172	323	239	18 x 1.5	263	194	363	268	27 mm
20 x 2.5	330	244	457	337	20 x 1.5	367	270	507	374	30 mm
22 x 2.5	451	332	623	460	22 x 1.5	495	365	684	505	34 mm
24 x 3.0	571	421	790	583	24 x 2.0	623	459	861	635	36 mm
30 x 3.0	1175	867	1626	1199	30 x 2.0	1258	928	1740	1283	46 mm

## SECTION 2 BLADE GUIDE ROLLERS & ARM

### 2.1 Blade Guide Assembly, Idle Side

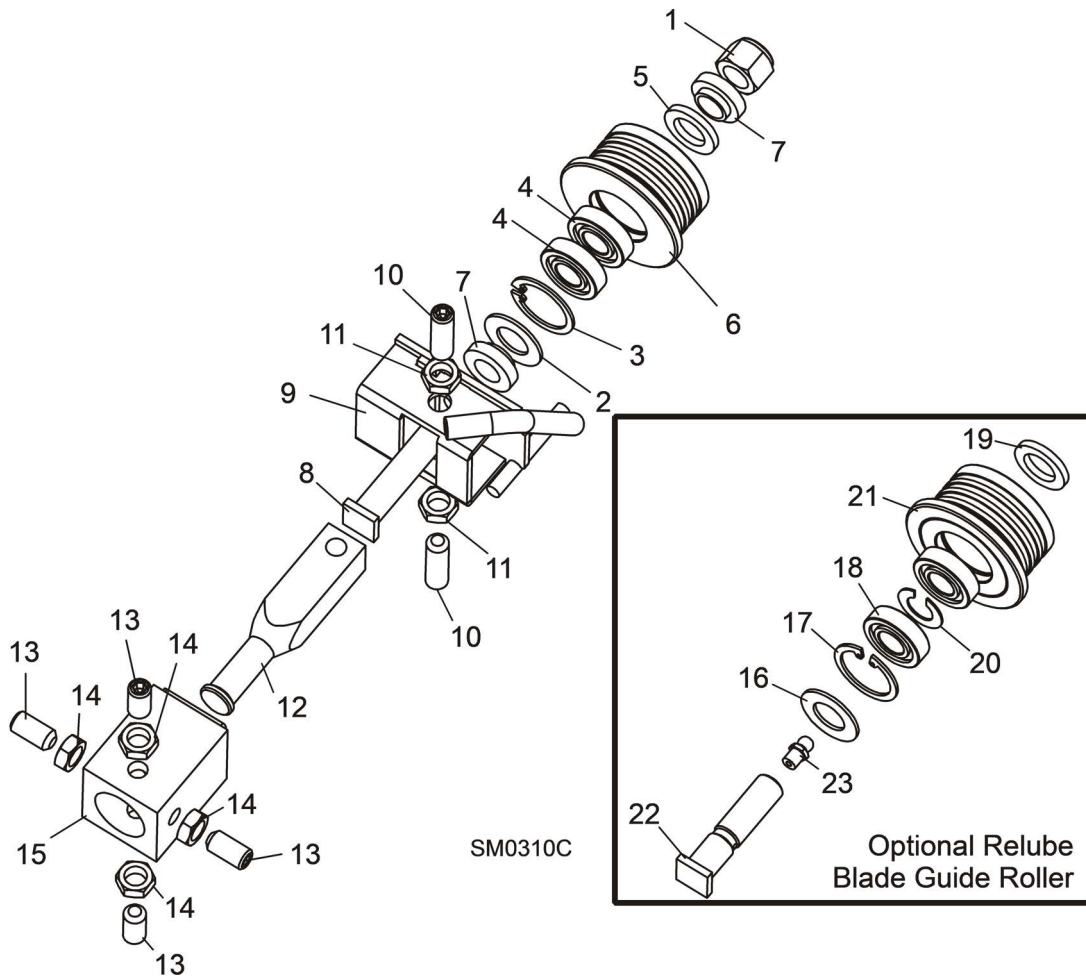

REF	PART #	DESCRIPTION	COMMENTS	QTY.
	A08197	<b>BLADE GUIDE ASSEMBLY, COMPLETE IDLE SIDE</b>		1
1	F05010-15	Nut, 1/2-20 Hex Nylon Lock		1
	A04925	Roller Assembly, Blade Guide (standard)		1
	K07079	Bearing Kit, Blade Guide Rebuild		1
2	P04252	Washer, 5/8" White Felt		1
3	F04254-1	Ring, 1 1/8" Interior Retaining		1
4	015975	Bearing, R8-2RS Blade Guide	Available in assemblies only.	2
5	P06455	Washer, 5/8" Gray Felt		1
	F05005-105	Screw, 1/4-28 x 1/4" Socket Head Cup Point Set Black Oxide		1
	057407-1507	Instruction Sheet, Blade Guide Rebuild		1
6	S04250	Roller, Flanged Blade Guide	Available in assemblies only.	1

## 2 Blade Guide Rollers & Arm

### Blade Guide Assembly, Idle Side

REF	PART #	DESCRIPTION	COMMENTS	QTY.
	A04925-364	Instruction Sheet, Blade Guide Roller Replacement		1
7	S04253	Spacer, Blade Guide		2
8	036373	Bolt, Blade Guide Roller		1
9	W08495	Bracket, Blade Guide Idle Side With Water Tube		1
10	F05007-96	Screw, 3/8-24 X 1 1/4" Stainless Steel Socket Head Flat Point		2
11	F05010-22	Nut, 3/8-24 Jam		2
12	S08196	Shaft, Blade Guide Adjustment		1
13	F05007-95	<b>SCREW, 3/8-24 X 3/4" STAINLESS STEEL SOCKET HEAD FLAT POINT</b>		4
14	F05010-22	<b>NUT, 3/8-24 JAM</b>		4
15	W08159	<b>TUBE, BLADE GUIDE MOUNT</b> ((See Section 2.3))		1
	016568	<b>ROLLER ASSEMBLY, BLADE GUIDE RELUBE (OPTIONAL)</b>		1
	057407	Bearing Kit, Relube Blade Guide Rebuild		1
16	P04252	Washer, 5/8" White Felt		1
17	F04254-1	Ring, 1 1/8" Interior Retaining		1
18	015975	Bearing, R8-2RS Blade Guide	Available in assemblies only. Bearing must be modified for use with relube roller assemblies. Remove one seal from each bearing, place open sides facing each other and place spacer 035411 between bearings.	2
19	P06455	Washer, 5/8" Gray Felt		1
	057407-1507	Instruction Sheet, Blade Guide Rebuild		1
20	035411	Spacer, Blade Guide Bearing		1
21	035426	Roller, Flanged Blade Guide Relube	Available in assemblies only.	1
	A04925-364	Instruction Sheet, Blade Guide Roller Replacement		1
22	S08192	<b>BOLT, BLADE GUIDE ROLLER (RELUBE ONLY)</b>		1
23	P05060	<b>FITTING, 1/4-28 GREASE (RELUBE ONLY)</b>		1



## 2.2 Blade Guide Assembly, Drive Side

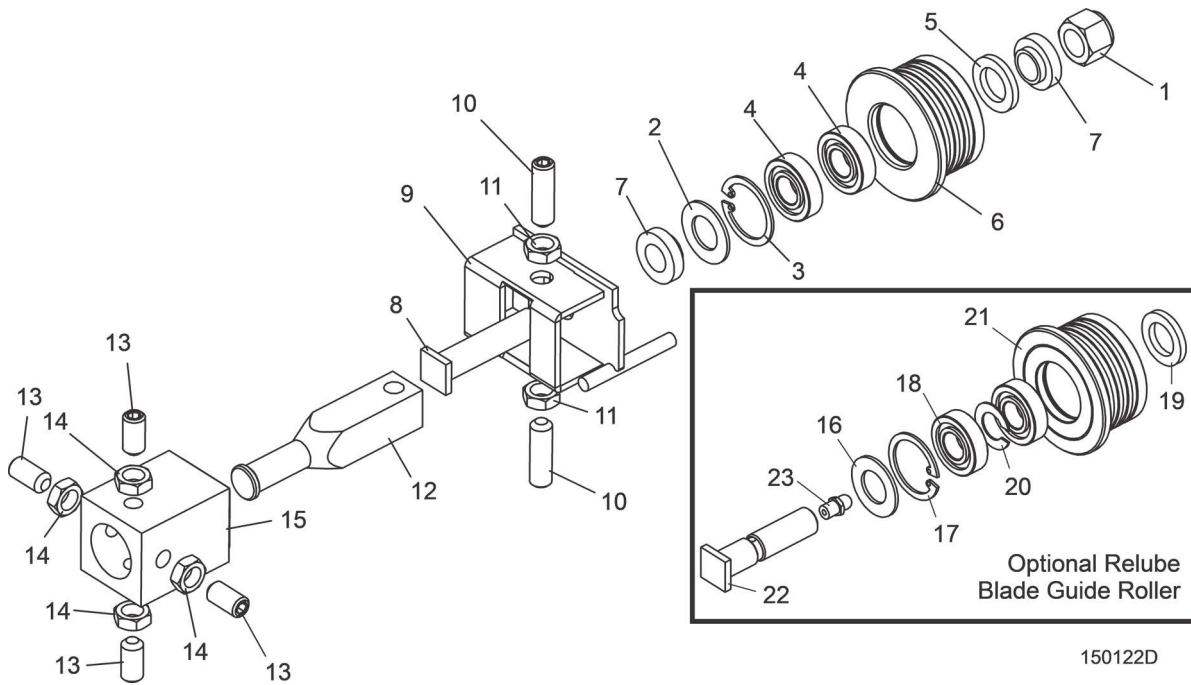

REF	PART #	DESCRIPTION	COMMENTS	QTY.
	A08191	<b>BLADE GUIDE ASSEMBLY, COMPLETE DRIVE SIDE</b>		1
1	F05010-15	Nut, 1/2-20 Hex Nylon Lock		1
	A04925	Roller Assembly, Blade Guide (standard)		1
	K07079	Bearing Kit, Blade Guide Rebuild		1
2	P04252	Washer, 5/8" White Felt		1
3	F04254-1	Ring, 1 1/8" Interior Retaining		1
4	015975	Bearing, R8-2RS Blade Guide	Available in assemblies only.	2
5	P06455	Washer, 5/8" Gray Felt		1
	F05005-105	Screw, 1/4-28 x 1/4" Socket Head Cup Point Set Black Oxide		1
	057407-1507	Instruction Sheet, Blade Guide Rebuild		1
6	S04250	Roller, Flanged Blade Guide	Available in assemblies only.	1
	A04925-364	Instruction Sheet, Blade Guide Roller Replacement		1
7	S04253	Spacer, Blade Guide		2
8	036373	Bolt, Blade Guide Roller		1
9	W08482	Bracket, Blade Guide Drive Side		1
10	F05007-96	Screw, 3/8-24 X 1 1/4" Stainless Steel Socket Head Flat Point		2
11	F05010-22	Nut, 3/8-24 Jam		2
12	S08196	Shaft, Blade Guide Adjustment		1
13	F05007-95	<b>SCREW, 3/8-24 X 3/4" STAINLESS STEEL SOCKET HEAD FLAT POINT SET</b>		3
14	F05010-22	<b>NUT, 3/8-24 JAM</b>		4
15	W08159	<b>TUBE WELDMENT, BLADE GUIDE MOUNT</b> (Part of saw frame weldment)		1

## 2 Blade Guide Rollers & Arm

Blade Guide Assembly, Drive Side

REF	PART #	DESCRIPTION	COMMENTS	QTY.
	016568	<b>ROLLER ASSEMBLY, BLADE GUIDE RELUBE (OPTIONAL)</b>		1
	057407	Bearing Kit, Relube Blade Guide Rebuild		1
<b>16</b>	P04252	Washer, 5/8" White Felt		1
<b>17</b>	F04254-1	Ring, 1 1/8" Interior Retaining		1
<b>18</b>	015975	Bearing, R8-2RS Blade Guide	Available in assemblies only. Bearing must be modified for use with relube roller assemblies. Remove one seal from each bearing, place open sides facing each other and place spacer 035411 between bearings.	2
<b>19</b>	P06455	Washer, 5/8" Gray Felt		1
<b>20</b>	035411	Spacer, Blade Guide Bearing		1
	057407-1507	Instruction Sheet, Blade Guide Rebuild		1
<b>21</b>	035426	Roller, Flanged Blade Guide Relube	Available in assemblies only.	1
	A04925-364	Instruction Sheet, Blade Guide Roller Replacement		1
<b>22</b>	S08192	<b>BOLT, BLADE GUIDE ROLLER (RELUBE ONLY)</b>		1
<b>23</b>	P05060	<b>FITTING, 1/4-28 GREASE (RELUBE ONLY)</b>		1

## 2.3 Blade Guide Arm

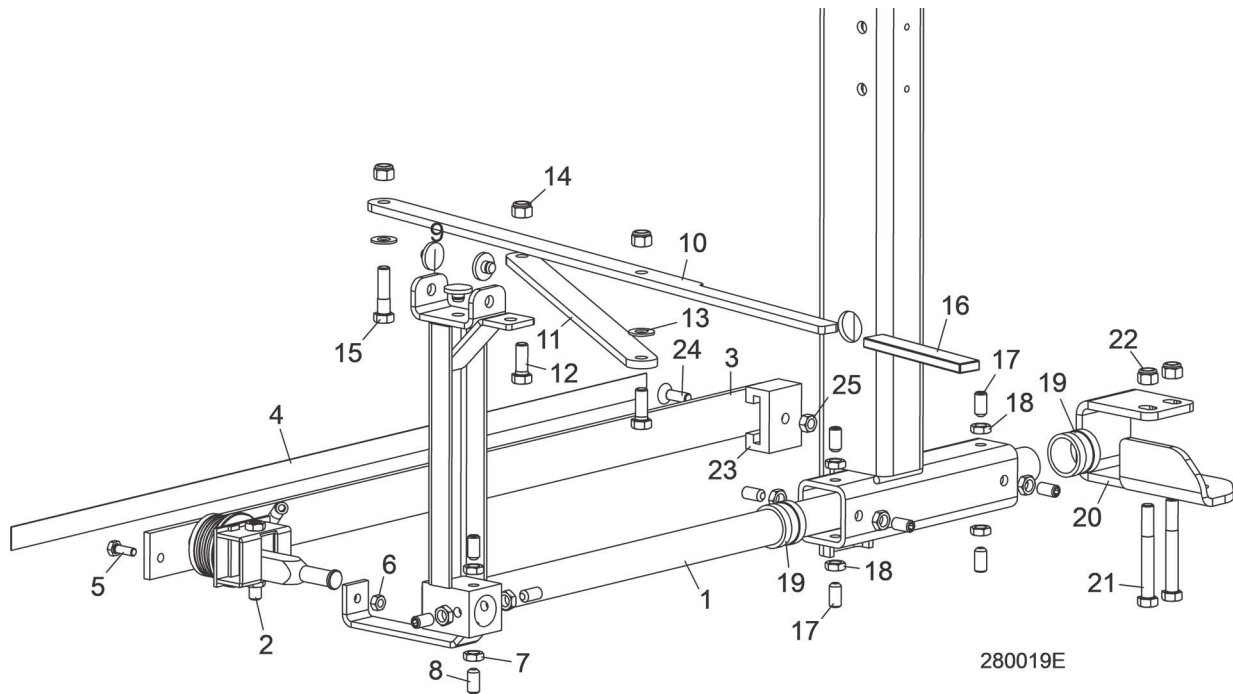

REF	PART #	DESCRIPTION	COMMENTS	QTY.
	046966	<b>ARM ASSEMBLY, LT15 BLADE GUIDE (2004)</b>		1
1	046965	Arm Weldment, LT15 Blade Guide (2004)		1
2		Blade Guide Parts	<a href="#">(See Section 2.1)</a>	
3	014955	Guard, LT15 Blade Guide Arm		1
4	015849	Decal, LT15 Blade Guide Arm		1
5	F05005-1	Bolt, 1/4-20 x 3/4" Hex Head Full Thread		1
6	F05010-21	Nut, 1/4-20 Hex Lock		1
7	F05010-22	Nut, 3/8-24 Hex Jam		4
8	F05007-95	Screw, 3/8-24 x 3/4" Socket Head Flat Point Set		4
9	014973	Pad, Blade Guide Slide		3
10	076118	<b>PLATE, LT15 WIDE BLADE GUIDE ARM ADJUSTMENT</b>		1
11	076117	<b>PLATE, LT15 WIDE BLADE GUIDE ARM LINK</b>		1
12	F05007-87	<b>BOLT, 3/8-16 X 1" HEX HEAD GRADE 5</b>		2
13	F05011-3	<b>WASHER, 3/8" SAE FLAT</b>		3
14	F05010-10	<b>NUT, 3/8-16 HEX NYLON LOCK</b>		3
15	F05007-78	<b>BOLT, 3/8-16 X 1 1/2" HEX HEAD GRADE 5</b>		1
16	049008	<b>GRIP, 5/8" ID RUBBER HANDLE</b>		1
17	F05007-95	<b>SCREW, 3/8-24 X 3/4" STAINLESS SOCKET HEAD FLAT POINT SET</b>		8
18	F05010-22	<b>NUT, 3/8-24 HEX JAM</b>		8
19	015899	<b>BUSHING, BLADE GUIDE ARM</b>		2
20	049141	<b>BRACKET, SAW HEAD REST</b>		1
21	F05007-73	<b>BOLT, 3/8-16 X 3" HEX HEAD GRADE 5</b>		2
22	F05010-10	<b>NUT, 3/8-16 HEX NYLON LOCK</b>		2
23	014882	<b>BRACKET, BLADE GUIDE ARM GUIDE</b>		1
24	F05006-124	<b>BOLT, 5/16-18 X 1" FLAT HEAD SOCKET</b>		1
25	F05010-6	<b>NUT, 5/16-18 HEX LOCK</b>		1

## SECTION 3 BLADE WHEELS & TENSIONER

### 3.1 Blade Drive Assembly

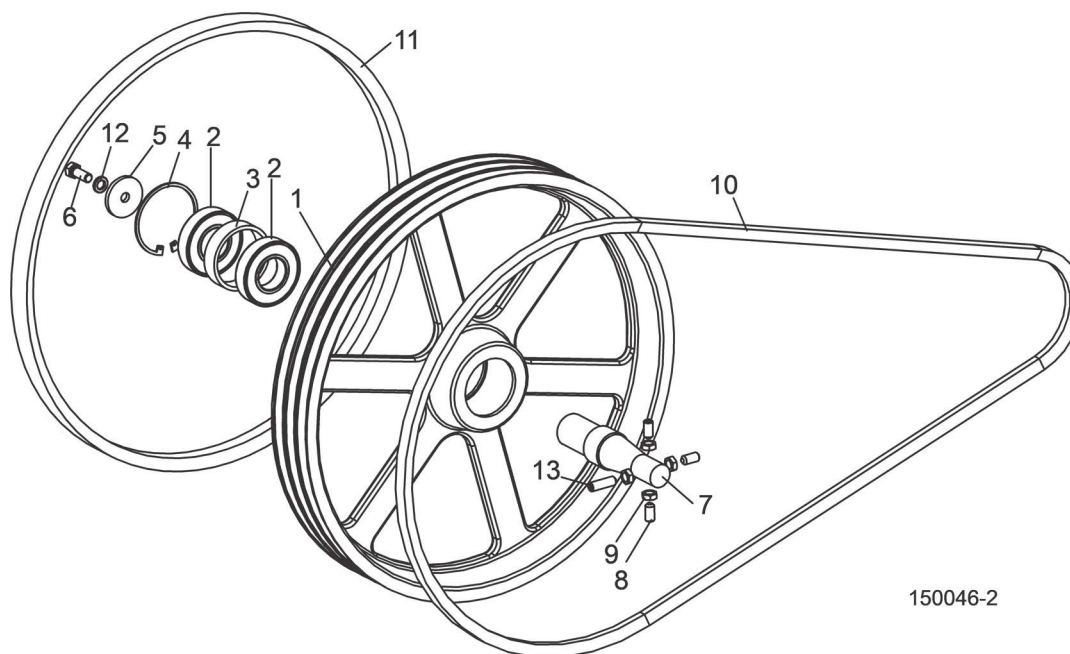

150046-2

REF	PART #	DESCRIPTION	COMMENTS	QTY.
		BLADE WHEEL BRAKE PARTS, G18	<a href="#">(See Engine Manual)</a>	
		BLADE WHEEL BRAKE PARTS, D17	<a href="#">(See Engine Manual)</a>	
		BLADE WHEEL BRAKE PARTS, D19	<a href="#">(See Engine Manual)</a>	
		BLADE WHEEL BRAKE PARTS, G25	<a href="#">(See Engine Manual)</a>	
	036657	WHEEL ASSEMBLY, DRIVE SIDE BLADE		1
1	047702	Wheel, Drive Side Blade		1
2	014811	Bearing, #6207 2RS		2
3	014730	Spacer, Drive Bearing		1
4	F04254-30	Ring, 3.121 IR Beveled Retaining		1
5	014728	WASHER, DRIVE WHEEL RETAINING		1
6	F05007-87	BOLT, 3/8-16 X 1" HEX HEAD		1
7	014729	SHAFT, LT15 DRIVE SIDE BLADE WHEEL		1
8	F05007-95	SCREW, 3/8-24 X 3/4" FLAT POINT SOCKET HEAD		3
9	F05010-22	NUT, 3/8-24 HEX JAM		4
10		BELT, DRIVE (SEE ENGINE MANUAL FOR PART #)	<a href="#">(See Section 5)</a>	1
11	P04185	BELT, B57		1
12	F05011-4	WASHER, 3/8" SPLIT LOCK		1
13	F05007-96	SCREW, 3/8-24 X 1 1/4" FLAT POINT SOCKET HEAD		1

### 3.2 Idle Blade Wheel Assembly

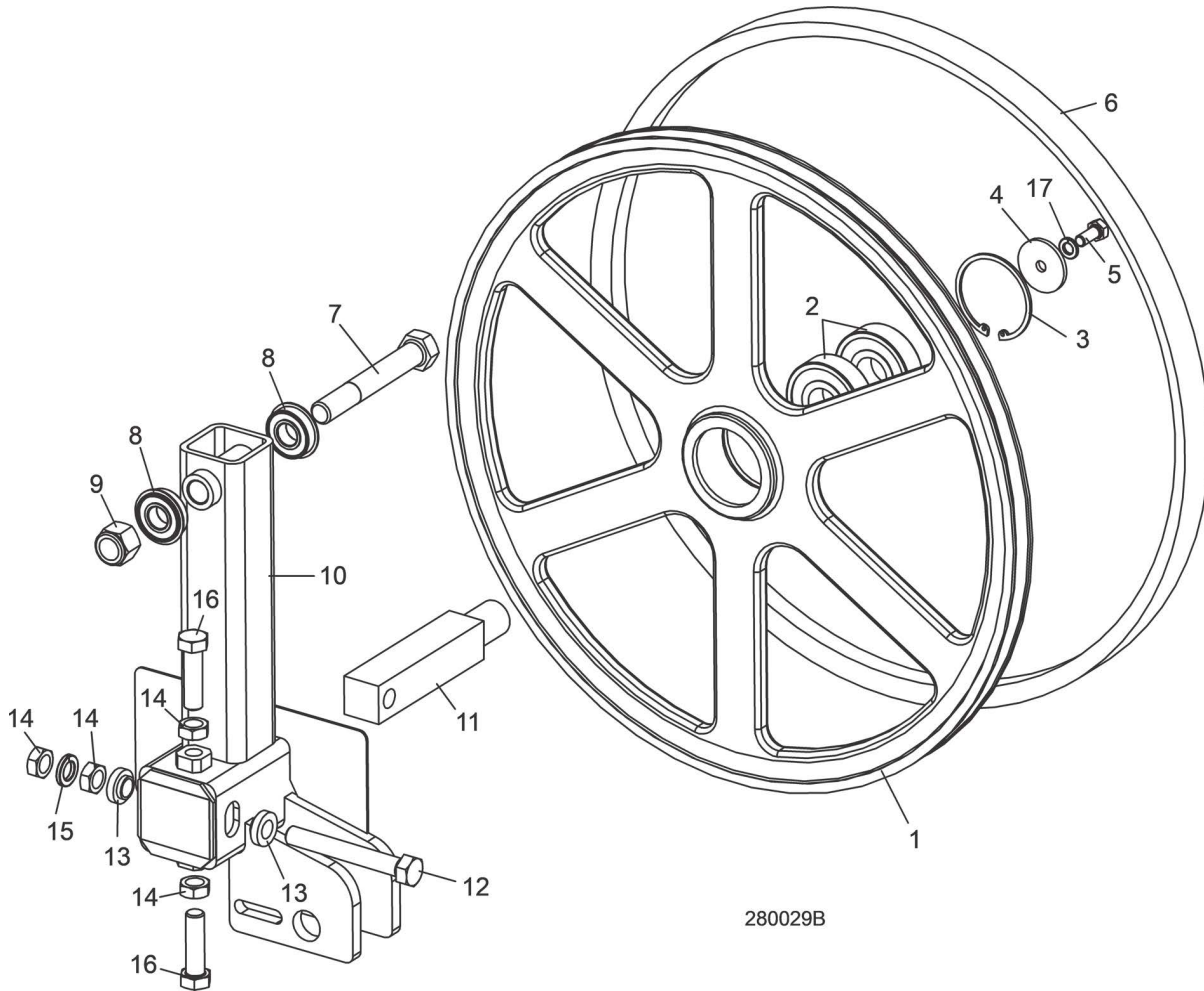

REF	PART #	DESCRIPTION	COMMENTS	QTY.
	A08218	<b>WHEEL ASSEMBLY, IDLE SIDE BLADE</b>		1
1	P08125	Wheel, Idle Side Blade	Available in assemblies only.	1
2	P08066	Bearing, Idle Side Blade Wheel #6305-AA, C3, ABEC-1, SRI-2 Grease		2
3	F04254-21	Ring, 2 7/16" Internal Retaining		1
4	S08220	<b>WASHER, IDLE BLADE WHEEL RETAINER</b>		1
5	F05006-102	<b>BOLT, 5/16-18 X 3/4" HEX HEAD</b>		1
6	P04185	<b>BELT, BLADE WHEEL B57</b>		1
7	F05009-3	<b>BOLT, 5/8-11 X 4 1/2" HEX HEAD</b>		1
8	014834	<b>BEARING, 5/8" I.D. W/SNAP RING</b>		2
9	F05010-34	<b>NUT, 5/8-11 HEX NYLON LOCK</b>		1
10	049349	<b>IDLER WELDMENT, BLADE WHEEL</b>		1
11	S12565	<b>SHAFT, IDLE WHEEL</b>		1
12	F05008-111	<b>BOLT, 1/2-20 X 3 3/4" HEX HEAD FULL THREAD GRADE 2</b>		1
13	S04253	<b>SPACER, 1/2" I.D. FLANGED</b>		2
14	F05010-16	<b>NUT, 1/2-20 HEX JAM</b>		4
15	F05011-9	<b>WASHER, 1/2" SPLIT LOCK</b>		1
16	F05008-127	<b>BOLT, 1/2-20 X 1 3/4" HEX HEAD GRADE 5</b>		2
17	F05011-13	<b>WASHER, 5/16" SPLIT LOCK</b>		1

### 3.3 Blade Tensioner Assembly

LT35 Rev. A6.05+  
LT35HD Rev A6.06+

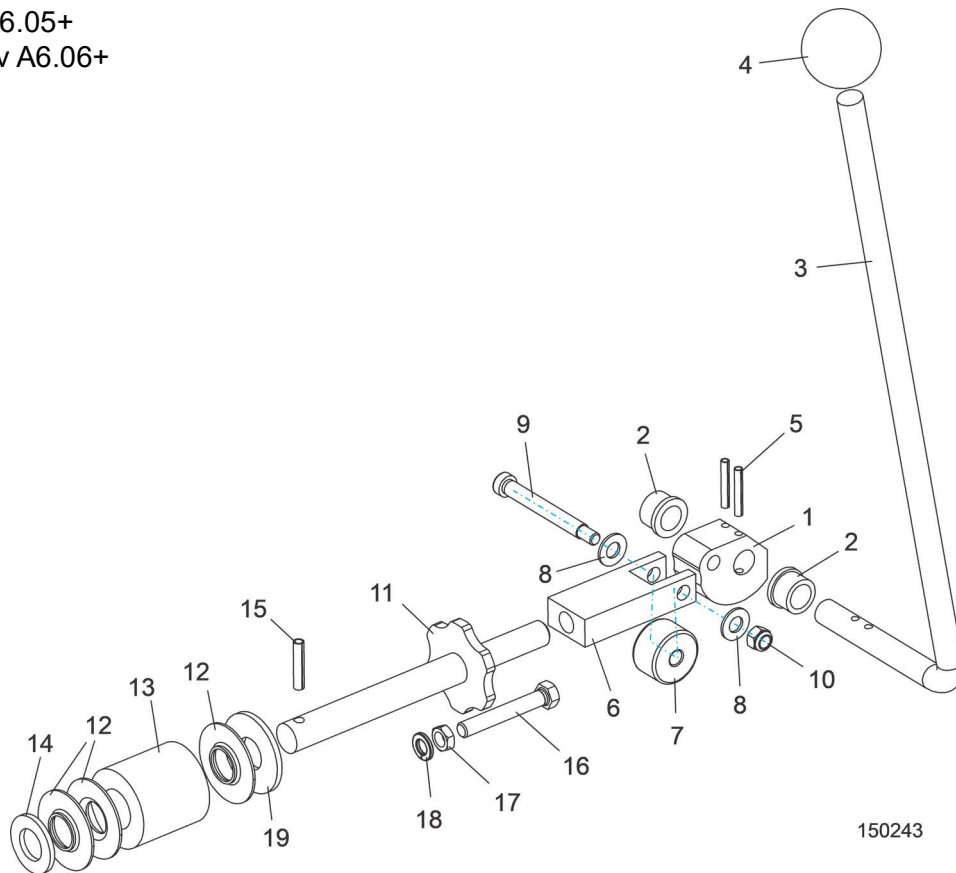

150243

REF	PART #	DESCRIPTION	COMMENTS	QTY.
	074801	<b>TENSION ASSEMBLY, CAM ACTUATED BLADE(LT15/28/35, HR120/130)</b>		1
1	049104	Cam, Tension		1
2	P05135	Bushing, 5/8" x 7/8" x 1/2" Bronze		2
3	103801	Handle, Blade Tensioner, LT15/28/35		1
4	P04211	Knob, 5/8-18 Ball		1
5	F05012-16	Pin, 3/16" x 1 1/4" Roll		2
6	128072	Block, Tensioner Bearing Mount		1
7	048219	Cam Follower, 3/8" x 1 3/8" x 13/16"		1
8	F05011-3	Washer, 3/8" SAE Flat		2
9	F05007-202	Bolt, 3/8 x 2 1/2" Socket Head Shoulder		1
10	F05010-58	Nut, 5/16-18 Hex Nylon Lock		1
11	038642	Shaft Weldment, Blade Tension		1
12	014925	Guide, Tension Handle		3
13	014828	Spring, Rubber Tensioner Blade		1
14	F05011-62	Washer, 3/4" SAE Flat		1
15	F05012-12	Pin, 1/4" x 1 1/4" Roll		1
16	F05007-157	Bolt, 3/8-16 x 2 1/2" Hex Head Full Thread		1
17	F05010-29	Nut, 3/8-16 Jam		1
18	F05011-4	Washer, 3/8" Split Lock		1
19	F05011-29	Washer, 3/4" USS Flat		1

LT35HD Rev A1.00-A6.05



## SECTION 4 SAW HEAD

### 4.1 Water Lube Assembly

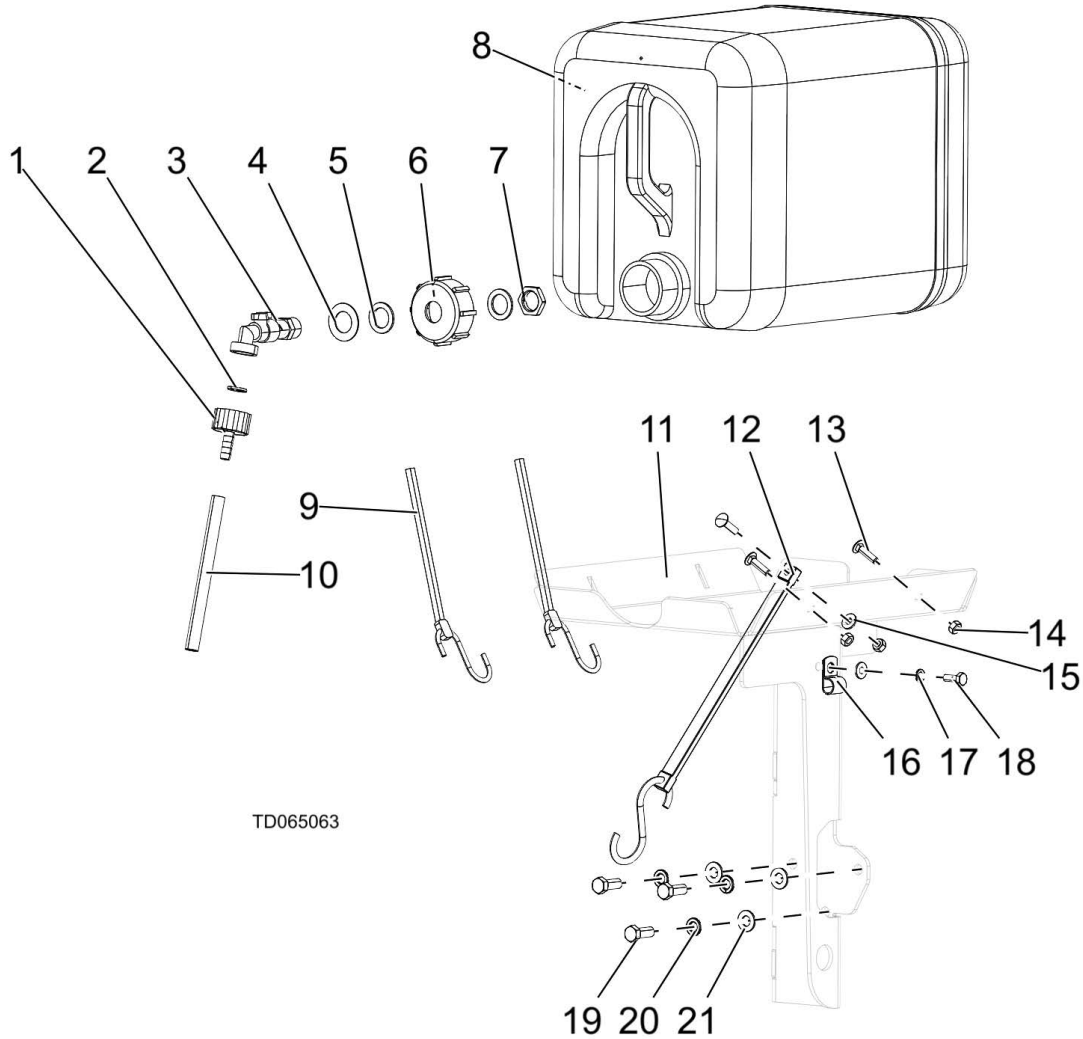

REF	PART #	DESCRIPTION	COMMENTS	QTY.
	065063	Tray Assembly, LT35 Water Lube Bottle		1
	550787	Assembly, Water Bottle		1
1	550777	Fitting, G3/4" X 10mm Hose Barb		1
2	550778	Gasket, 1/2 (Batard)		1
3	550776	Fitting, Water Lube Shutoff Valve		1
4	530841	Shim, 21/37-1		1
5	550780	O-ring, 27x20x1.5		2
6	550785	Cap, Water Bottle		1
7	550779	Gland Nut, 1/2 Npt		1
8	513866	Bottle, Water		1
9	P11668	Strap, 20 Rubber W/hooks		2
10	R01885	Hose, Water Lube Stock		1
11	062530	Tray Weldment, Lt35 Water		1



REF	PART #	DESCRIPTION	COMMENTS	QTY.
12	012965	Strap, Rubber 9"		1
13	F05005-34	Bolt, 1/4-20 X 1 Carr		3
14	F05010-21	Nut, 1/4-20 Swaged		3
15	F05011-11	Washer, 1/4 SAE Flat		2
16	P07584	Clamp, 1/2emt Coated		1
17	F05011-14	Washer, 1/4 Split Lock		1
18	F05005-1	Bolt, 1/4-20x3/4 Ft Hhc		1
19	F05007-87	Bolt, 3/8-16x1 Gr5 Hh		3
20	F05011-4	Washer, 3/8 Split Lock		3
21	F05011-3	Washer, 3/8 Flat SAE		3

## 4.2 Saw Head Decals

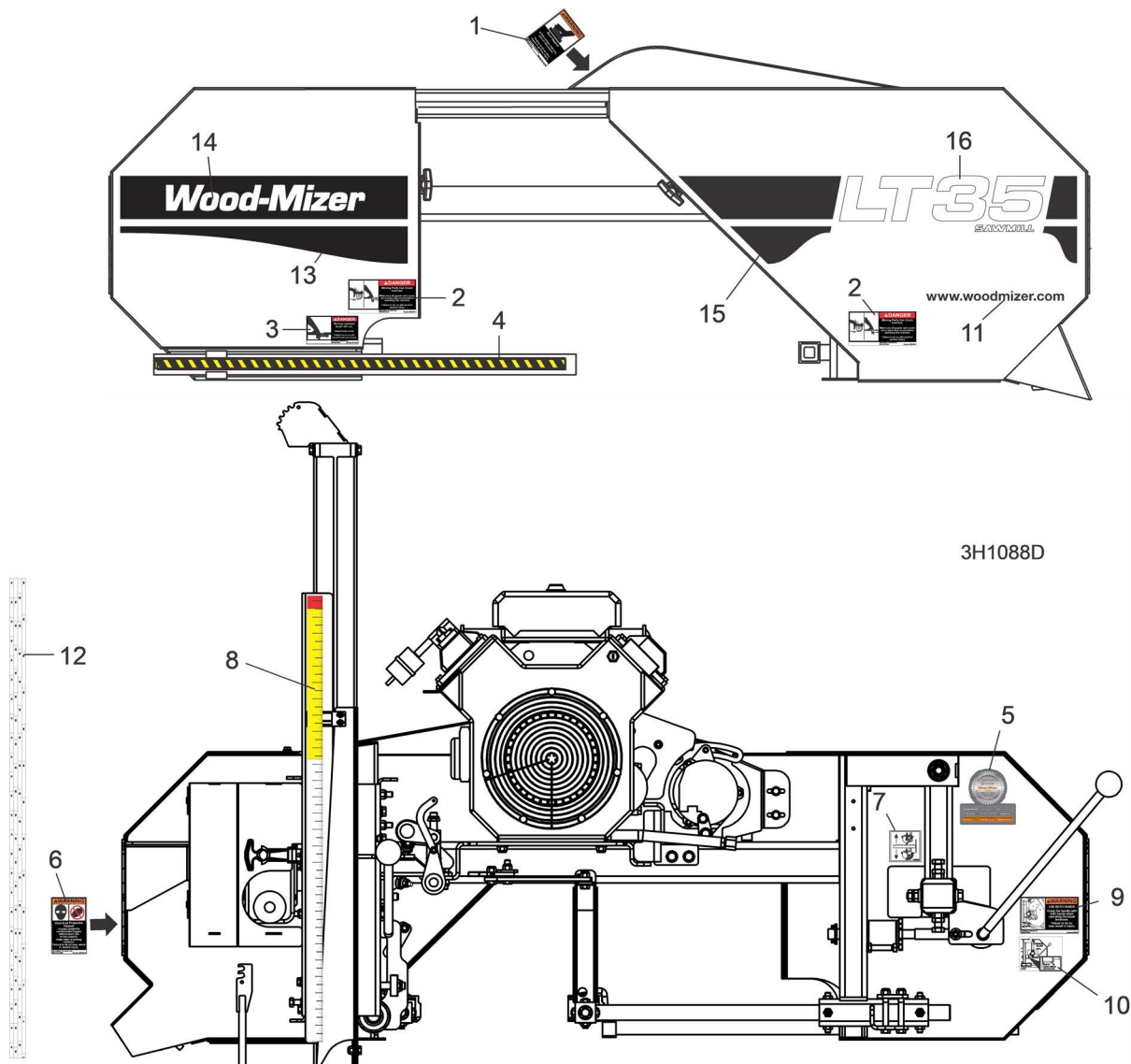

REF	PART #	DESCRIPTION	COMMENTS	QTY.
1	014419	DECAL, HOT ENGINE WARNING		1
2	033254	DECAL, MOVING PARTS DANGER		2
3	S11752	DECAL, BLADE DANGER W/ARROW		1
4	015849	DECAL, BLADE GUIDE ARM STRIPE		1
5	079278	DECAL, WOOD-MIZER QUALITY & INFORMATION		1
6	P11754	DECAL, SAWDUST CHUTE WARNING		1
7	P11789	DECAL, BLADE TRACK INFO		1
8	S11773	DECAL, INCH SCALE		1
9	049367	DECAL, TENSIONER WARNING		1
10	049368	DECAL, BLADE TENSION INFO		1
11	003235	DECAL, WOOD-MIZER WEBSITE		1
12	016275	DECAL, MAGNETIC QUARTER SCALE		1
13	065008	DECAL, LT15/28/35 IDLE SIDE BLACK EURO STRIPE		1
14	065002	DECAL, LT10/15/28/35 WHITE WOOD-MIZER LOGO		1
15	065010	DECAL, LT28/35 DRIVE SIDE BLACK EURO STRIPE		1
16	065022	DECAL, LT35 WHITE EURO LOGO		1

### 4.3 Blade Housing Covers

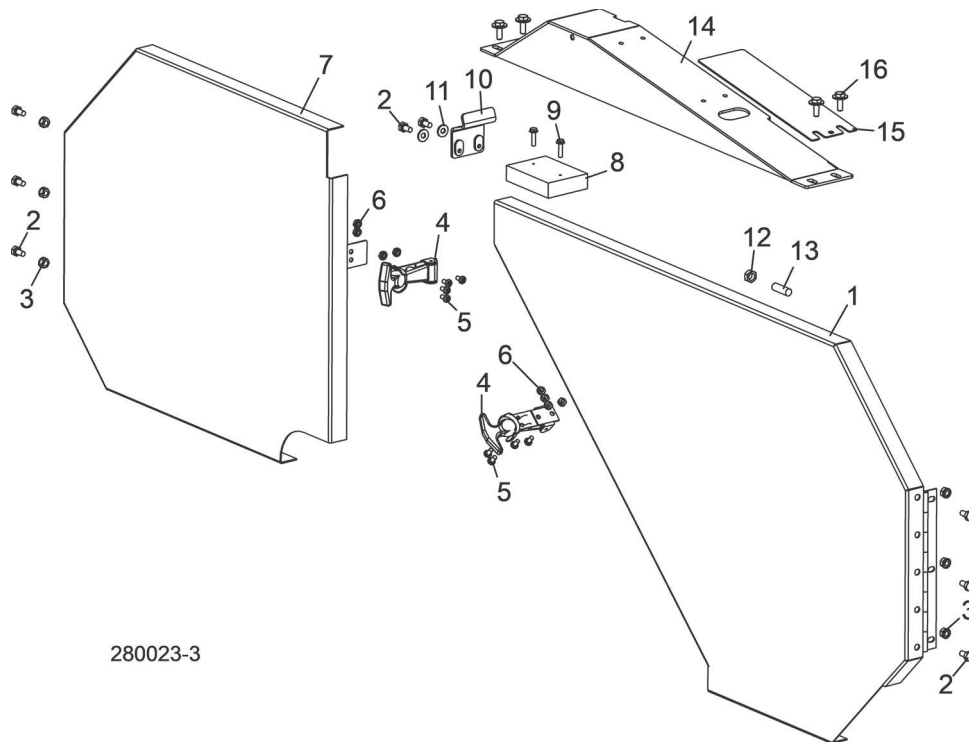

280023-3

REF	PART #	DESCRIPTION	COMMENTS	QTY.
1	065067	COVER, LT35 DRIVE SIDE BLADE HOUSING (INCLUDES COVER DECALS - <a href="#">(See Section 4.2)</a> )		1
2	F05005-15	BOLT, 1/4-20 X 1/2" HEX HEAD		8
3	F05010-9	NUT, 1/4-20 KEPS		6
4	014829	LATCH, FLEXIBLE DRAW		2
5	F05004-3	SCREW, #10-24 X 3/8" CROSS SLOTTED ROUND HEAD		8
6	F05010-14	NUT, #10-24 SELF-LOCKING HEX		8
7	065068	COVER, LT35 IDLE SIDE BLADE HOUSING (INCLUDES COVER DECALS - <a href="#">(See Section 4.2)</a> )		1
8	015844	BLOCK, BLADE VIBRATION DAMPENING		1
9	F05015-33	BOLT, #10 X 3/4" SLOTTED HEX WASHER HEAD		2
10	074394	BRACKET WELDMENT, LT15 BELT ENHANCE	Used ONLY with engine models G25 & D17. EXCLUDED with engine model D24.	1
11	F05011-11	WASHER, 1/4" SAE FLAT		2
12	F05010-29	NUT, 3/8-16 JAM		1
13	F05007-18	SCREW, 3/8-16 X 1 1/4 SHOP SET		1
	038633	COVER ASSEMBLY, TOP ENGINE PULLEY		1
14	074574	Cover Weldment, LT15/28 Top Belt Cover		1
15	074546	Plate, Belt Guard Cover		1
16	F05005-134	Bolt, 1/4-20 x 3/4" Hex Head w/Conical Washer		4

## 4.4 Sawdust Chute

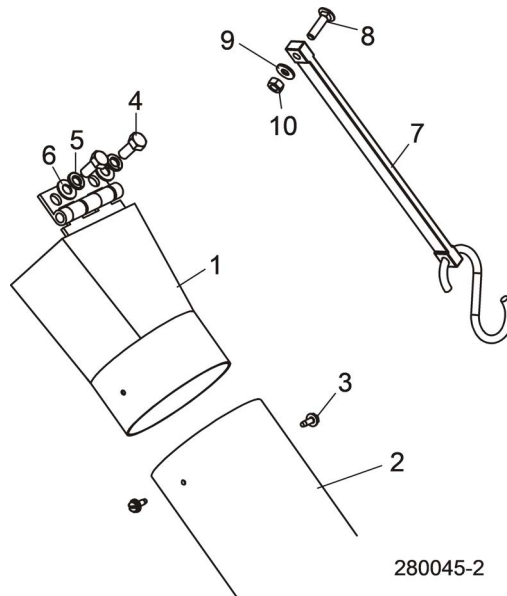

REF	PART #	DESCRIPTION	COMMENTS	QTY.
<b>1-6</b>	038747	<b>CHUTE ASSEMBLY, LT28 SAWDUST</b>		1
<b>1</b>	038746	Chute Wldmt, LT28 Sawdust		1
<b>2</b>	016727	Chute, Rubber Sawdust		1
<b>3</b>	F05015-7	Bolt, #10-24x1/2 Self Tap		2
<b>4</b>	F05006-5	Bolt, 5/16-18x3/4 HHC		2
<b>5</b>	F05011-13	Washer, 5/16 Split Lock		2
<b>6</b>	F05011-17	Washer, 5/16 SAE Flat		2
<b>7</b>	012965	<b>STRAP, 9IN RUBBER WITH HOOKS</b>		1
<b>8</b>	F05005-34	<b>BOLT, 1/4-20X1 CARRIAGE</b>		1
<b>9</b>	F05011-11	<b>WASHER, 1/4 SAE FLAT</b>		1
<b>10</b>	F05010-21	<b>NUT, 1/4-20 SWAGED</b>		1

# SECTION 5 CONTROL & BATTERY BOXES

## 5.1 Control Assembly

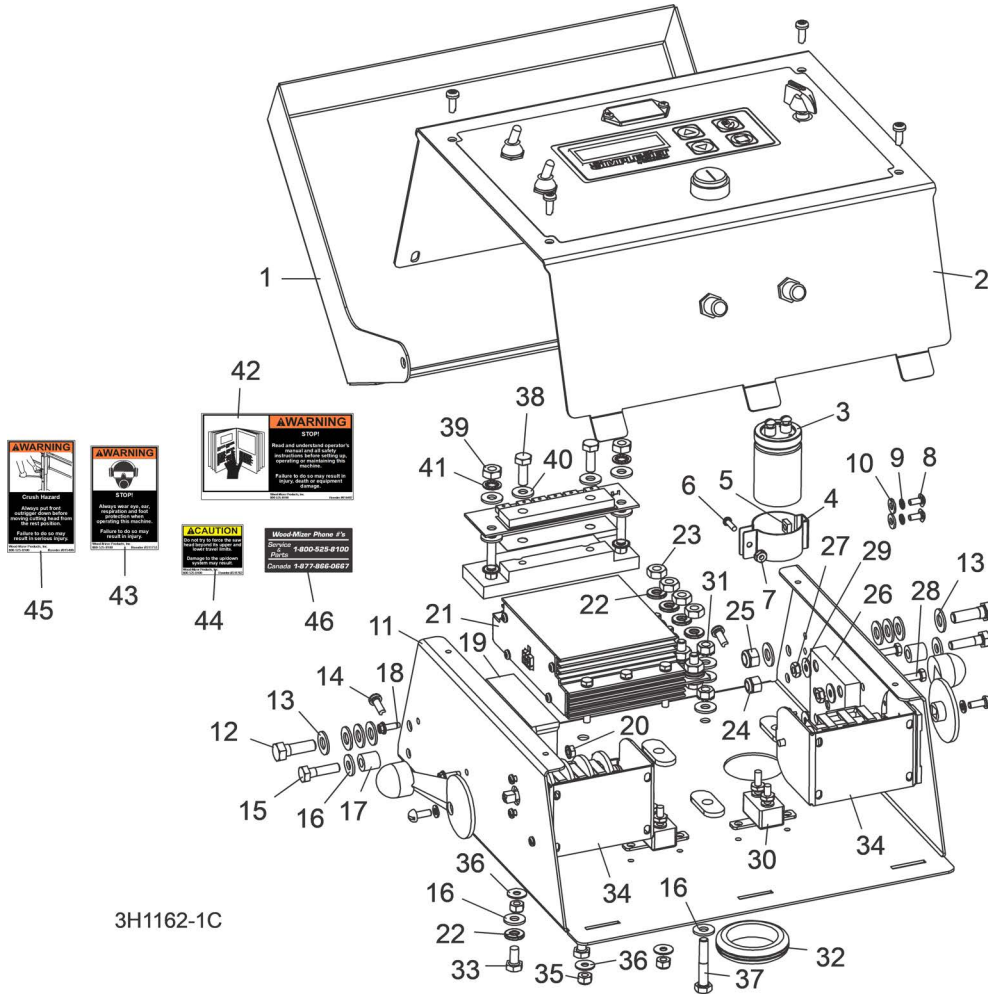

3H1162-1C

REF	PART #	DESCRIPTION	COMMENTS	QTY.
	073542	<b>CONTROL ASSEMBLY, LT35D17/G25 POWER FEED</b>		1
	073559	<b>CONTROL ASSEMBLY, LT35D24 POWER FEED</b>		1
1	071337	Plate, LT35 Control Box Cover		1
2	N/A	LT35 Operator Panel Parts	<a href="#">(See Section 5.5)</a>	1
3	052365	Capacitor Assembly, PF Filter		1
4	024410	Clamp, Capacitor Metal 1-3/8 Cylindrical		1
5	F05010-153	Nut, #8-32 Square		2
6	F05015-24	Screw, #6-32 x 1/2" SI RH		1
7	F05010-59	Nut, #6-32 Keps		1
8	F05004-157	Screw, #8-32 x 3/8" Round Hd Mach Grade 5		2
9	F05011-84	Washer, #8 Split Lock		2
10	F05011-41	Washer, #8 SAE Flat		2
11	071335	Box Weldment, LT35 Control Bottom		1
12	F05006-1	Bolt, 5/16-18 x 1" Hex Head		2
13	F05011-17	Washer, 5/16" SAE Flat		10
14	F05015-17	Bolt, #10-24 x 1/2 Ph Pan Hd, Type 23		7

REF	PART #	DESCRIPTION	COMMENTS	QTY.
15	F05005-101	Bolt, 1/4-20 x 1" Hex Head Grade 5		2
16	F05011-11	Washer, 1/4" SAE Flat		8
17	076008	Bushing, 1/4" IDx1/2" OD Nylon		2
18	F05015-18	Bolt, #8-32 x 1/2" SI Hex Head		2
19	024396-1	Control Module, Power Feed SMT		1
	052294	Suppressor Assembly, 92+ Power Feed		1
20	F05010-41	Nut, #8-32 Keps		2
21	053373	H-Bridge Assembly, SimpleSet		1
22	F05011-14	Washer, 1/4" Split Lock		4
23	F05010-129	Nut, 1/4-20 Jam Heavy Duty		4
24	F05010-69	Nut, 1/4-20 Nylock		2
25	F05010-58	Nut, 5/16-18 Nylok Hex		2
26	024404	Block, Diode Heat Sink		1
	024403	Pad, Diode Block Insulating		1
	024409	Insulator, Nylon Screw #10 1/2in		4
27	F05010-14	Nut, #10-24 Keps		4
28	F05004-156	Bolt, #10-24 x1 Unslotted Hex Head Grade 2		4
29	F05011-18	Washer, #10 SAE Flat		4
30	053464	Breaker, 10A Manual Reset		2
31	F05010-9	Nut, 1/4-20 Keps		2
32	053784	Grommet, 25Pk 1-1/2" ID Rubber		1
33	F05005-15	Bolt, 1/4-20 x 1/2" Hex Head		2
34	N/A	Drum Switch Parts	<a href="#">(See Section 5.2)</a>	2
35	F05010-160	Nut, 10-24 Hex Nylock		4
36	F05011-18	Washer, #10 SAE Flat		4
37	F05005-31	Bolt, 1/4-20x1 1/2 HH FT		1
	024387	Module Assembly, Mosfet SMT 97+ P/F		1
38	F05005-1	Bolt, 1/4-20x3/4 FT HHC		2
39	F05010-129	Nut, 1/4-20 Jam Heavy Duty		2
40	F05011-11	Washer, 1/4" SAE Flat		6
41	F05011-69	Washer, 1/4" Int Star Heavy Duty		2
	073778	Harness Assembly, LT35 Simple Set Drum Switch		1
	073502	Harness Assembly, LT35 Upper (D17/G25 Only)		1
	073558	Harness Assembly, LT35 Upper (D24 Only)		1
	053632-FR	Cable Assembly, Remote SimpleSet Sensor		1
	052363	Diode Assembly, 96+ PF Replacement		1
42	016402	<b>DECAL, READ MANUAL WARNING</b>		1
43	S11753	<b>DECAL, EYE/EAR PROTECTION WARNING</b>		1
44	S11762	<b>DECAL, UP/DOWN CAUTION</b>		1
45	015400	<b>DECAL, FRONT OUTRIGGER WARNING</b>		1
46	S12117	<b>DECAL, 800 NUMBER</b>		1

## 5.2 Drum Switches

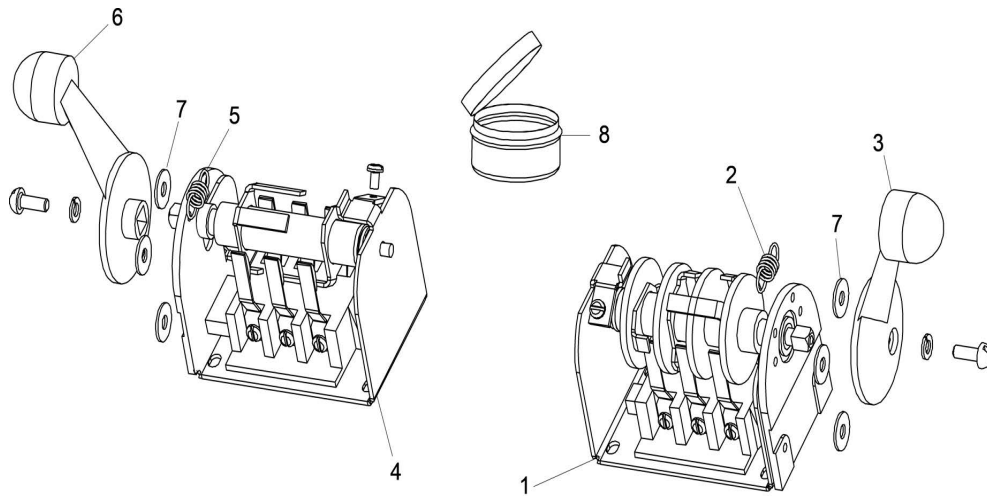

3H0421

REF	PART #	DESCRIPTION	COMMENTS	QTY.
	E20440	<b>SWITCH ASSEMBLY, UP/DOWN DRUM</b>		1
1	E20440-B	Switch, S12 Bulk Drum	Available in assemblies only.	1
2	P12570	Spring, Drum Switch		1
3	P12500	Handle, Drum Switch Replacement		1
	E20439	<b>SWITCH ASSEMBLY, POWER FEED DRUM</b>		1
4	E20439-B	Switch, S11 Bulk Drum	Available in assemblies only.	1
5	P12570	Spring, Drum Switch		1
6	P12500	Handle, Drum Switch Replacement		1
7	F05011-41	<b>WASHER, #8 SAE FLAT</b>		6
8	A20463	<b>CUP ASSEMBLY, DRUM SWITCH GREASE</b>		1

### 5.3 Front Panel Assembly

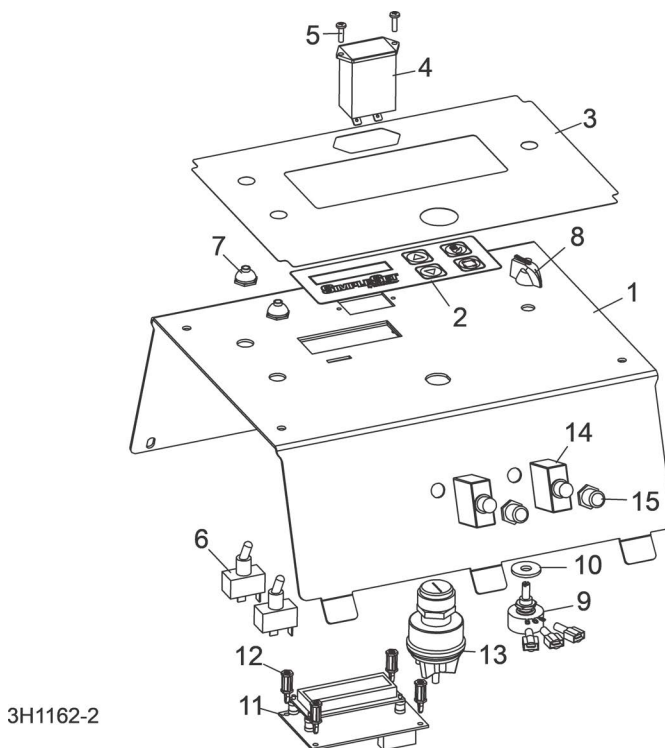

REF	PART #	DESCRIPTION	COMMENTS	QTY.
	073541	<b>PANEL ASSEMBLY, LT35 OPERATOR</b>		1
<b>1</b>	071339	Top Weldment, LT35 Control Box		1
<b>2</b>	053347	Membrane, SimpleSet Switch		1
<b>3</b>	071341	Decal LT35 Control Box		1
<b>4</b>	015401	Meter, Hour		1
<b>5</b>	F05015-28	Screw, #6-32 x 1/2" Plain PH T23		2
<b>6</b>	P03027	Switch, SPST On/Off 15A .25 Tabs Toggle		2
<b>7</b>	P02575	Boot, Toggle Switch		2
<b>8</b>	P06257	Knob, Speed Control		1
<b>9</b>	076050	Pot Assembly, w/Terminals		1
<b>10</b>	F05011-16	Washer, 5/16" Standard Flat		1
<b>11</b>	073540-FR	SimpleSet Controller, LT35 (Field Replacement)		1
<b>12</b>	053385	Standoff, 5/8" Threaded PCB		4
<b>13</b>	P04350	Switch, Key		1
<b>14</b>	021256	Breaker, 50A Manual Reset Panel Mount		2
<b>15</b>	021253	Boot, Circuit Breaker		2
	R02309	Foam, 3/16x1/2 Adhesive Back Rubber		2 ft.



## 5.4 Battery Box Assembly

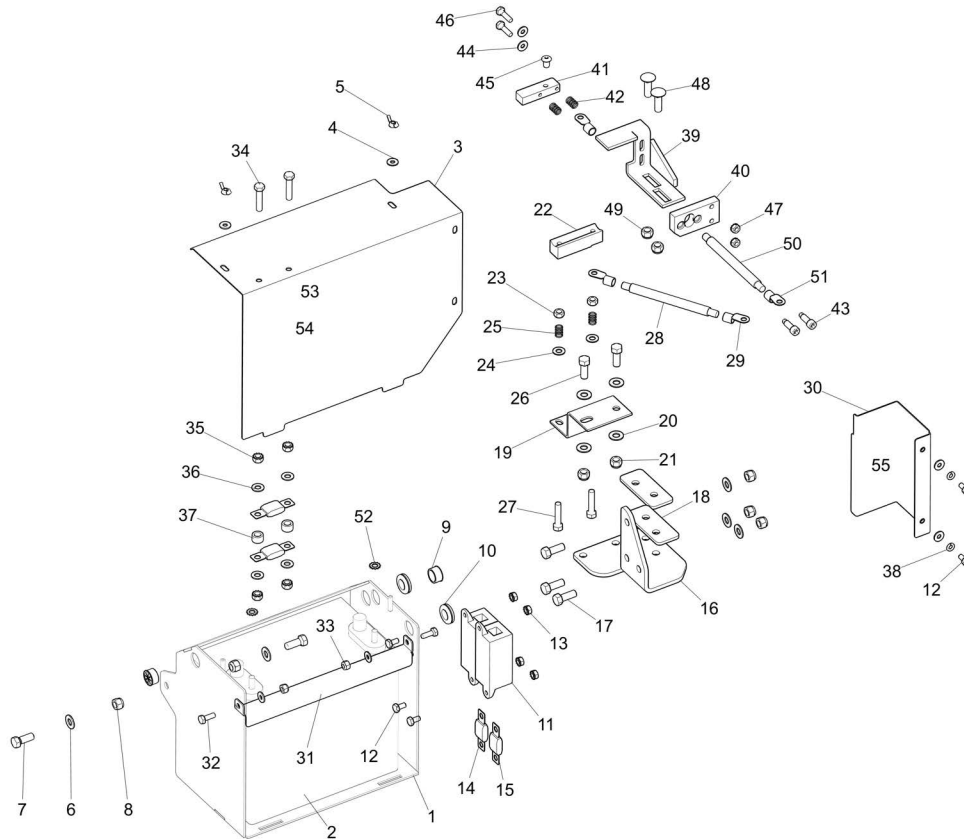

TD062541  
TD062541

REF	PART #	DESCRIPTION	COMMENTS	QTY.Q TY
	062541	Battery Box Assy, LT35		1
1	062542	Box Widmt, LT35 Battery		1
2	p12315	Battery, 12V 8800MF		1
3	062546	Cover, LT35 Battery		1
4	f05011-11	Washer, 1/4 SAE Flat		6
5	f05010-13	Nut, 1/4-20 Wing		2
6	f05011-3	Washer, 3/8 Flat SAE		5
7	f05007-87	Bolt, 3/8-16x1 Gr5 HH		2
8	f05010-10	Nut, 3/8-16 Hex Nyl Lock		5
9	p04137	Grommet, 5/8 Wire		2
10	p11764	Grommet, 5/8 ID Rubber		2
11	052371	Fuseholder, Mega Fuse		2
12	f05005-15	Bolt, 1/4-20x1/2 HH		6
13	f05010-9	Nut, 1/4-20 Keps		4
14	052370-150	Fuse, 150A 32V Mega		2
15	053339	Fuse, 225A 32V Mega		2
16	059636	Plate, LT35 Contact Mount		1
17	f05007-7	Bolt, 3/8-16x1 HH		3
18	025964	Plate, LT35 Positive Contact Spacer		2
	065081	Contact Assy, LT35 Ground Hyd Power		1
19	016792	Plate, HPS Ground Contact Mount		1

# 5 Control & Battery Boxes

## Battery Box Assembly

REF	PART #	DESCRIPTION	COMMENTS	QTY.Q TY
20	f05011-3	Washer, 3/8 Flat SAE		4
21	f05010-10	Nut, 3/8-16 Hex Nyl Lock		2
22	015264	Block, Exten. Hyd Ground Contact		1
23	f05010-17	Nut, 5/16-18 Hex		2
24	f05011-17	Washer, 5/16 SAE Flat		2
25	p10077	Spring, .42x.59x.042 Comp		2
26	f05007-7	Bolt, 3/8-16x1 HH		2
27	f05008-96	Bolt, 5/16-18x1 1/2 HH Gr5		2
	036306	Cable Assy, 1AWG Black x26		1
28	r01971	Cable, 1AWG SO Welding, Black		1
29	f05092-16	Terminal, 5/16 1-2Ga Ring NI Loose		2
30	065040	Wldmnt, LT35 Fuse Cover		1
31	065082	Plate, Battery Hold Down		1
32	f05005-123	Bolt, 1/4-20x3/4 HH Gr5		2
33	f05010-69	Nut, 1/4-20 Nylock		2
34	f05006-2	Bolt, 5/16-18x1 1/2 HH FT		2
35	f05010-20	Nut, 5/16-18 Keps		4
36	f05011-17	Washer, 5/16 SAE Flat		4
37	055323	Spacer, .39x.625x.39		2
38	f05011-14	Washer, 1/4 Split Lock		2
	010103	Contact Assy, Positive Hyd. Power (97+)		1
39	015324	Plate Wdmt, Hot Contact		1
40	s10072	Plate, 1/2 Nyl Insulator Contact		1
41	015253	Button, Hot Contact 1997		1
42	p10077	Spring, .42x.59x.042 Comp		2
43	f05006-143	Bolt, 5/16x3/4 Shoulder (1/4-20 Thread)		2
44	f05011-11	Washer, 1/4 SAE Flat		2
45	f05006-20	Screw, 5/16-18x1/2 SBH		1
46	f05005-38	Screw, 1/4-20x1 HHC		2
47	f05010-9	Nut, 1/4-20 Keps		2
48	f05007-11	Bolt, 3/8-16x1 1/4 Carriage		2
49	f05010-10	Nut, 3/8-16 Hex Nyl Lock		2
	128088	Cable Assy, 1AWG Red x13		1
50	r01971-1	Cable, 1AWG SO Welding, Red		1
51	f05092-16	Terminal, 5/16 1-2Ga Ring NI Loose		2
52	f05011-33	Washer, 5/16 Star ET		2
53	P12960	Decal, Hydraulic Contact Caution		1
54	P10364	Decal, 12V Warning		1
55	014774	Decal, Battery Box Lid Caution		1
		Hydraulic Positive Contact Parts <a href="#">((See Section 9.3))</a>		

## SECTION 6 UP/DOWN SYSTEM

### 6.1 Saw Head Mount

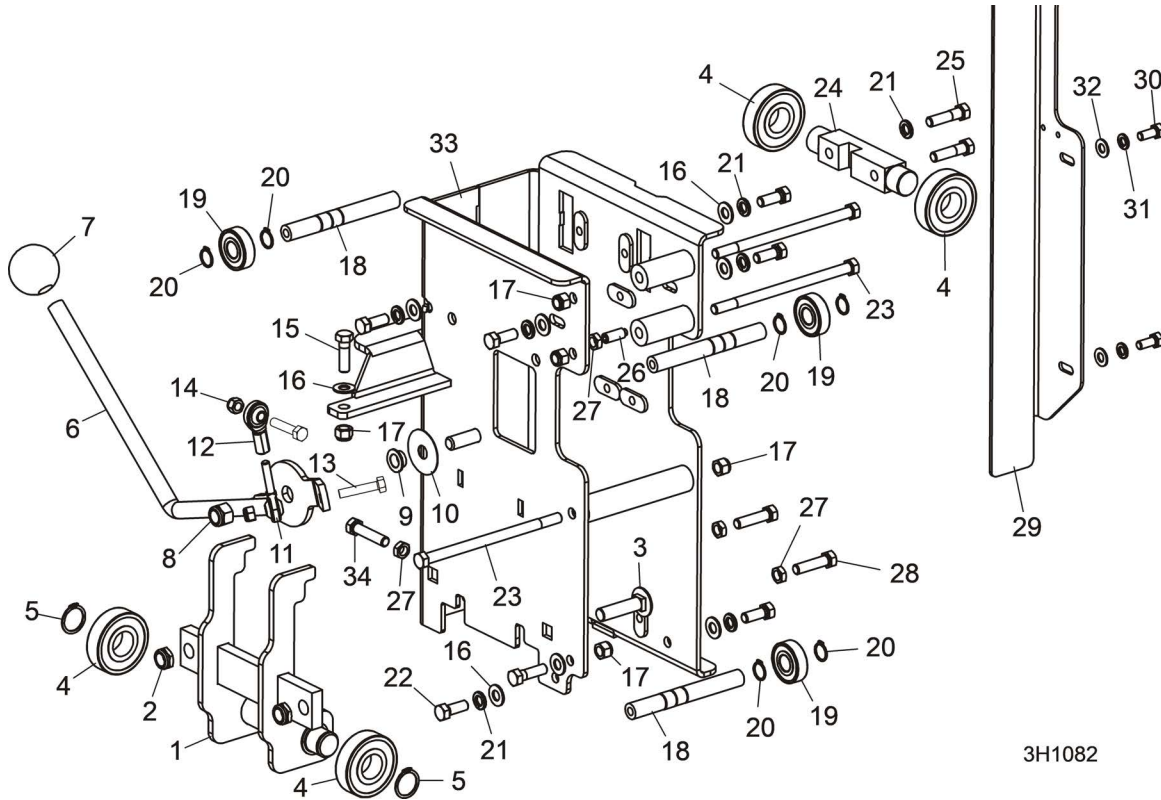

REF	PART #	DESCRIPTION	COMMENTS	QTY.
	062519	<b>BOX ASSEMBLY, LT35 MAST</b>		1
1	048562	Adjustment Weldment, Head LT28		1
2	F05010-127	Nut, 1/2-13 Half Nylon Lock		2
3	F05008-132	Bolt, 1/2-13x2 Carriage		2
4	P08066	Bearing, .9843" x 2.4409" x .6693"		4
5	F04254-26	Ring, 25mm 5100-98 OR		1
6	003327	Plate, Clutch Handle		1
7	P04211	Knob, 5/8-18 Ball		1
8	F05010-8	Nut, 1/2-13 Nylon Hex Lock		1
9	P08060	Bearing, SF1260-6 Bronze		1
10	014972	Washer, 33/64 x 1 3/4 x 1/32 Nylon		1
11	P09814	Rod, 5/16-24 Male End		1
12	P09813	Rod, 5/16-24 Female End		1
13	F05008-96	Bolt, 5/16-18 x 1 1/2" Hex Head		2
14	F05010-58	Nut, 5/16-18 Nylon Lock		2
15	F05007-123	Bolt, 3/8-16 x 1 1/4" Hex Head Grade 5		1
16	F05011-3	Washer, 3/8" SAE Flat		6
17	F05010-10	Nut, 3/8-16 Hex Nylon Lock		5
18	048559	Shaft, Bearing Mount		3
19	P06030-1	Bearing, 5/8" x 1.7548" x .4724"		3
20	F04254-2	Ring, 5/8" OR 5100-62		6

REF	PART #	DESCRIPTION	COMMENTS	QTY.
21	F05011-4	Washer, 3/8" Split Lock		7
22	F05007-87	Bolt, 3/8-16 x 1" Hex Head Grade 5		5
23	F05007-205	Bolt, 3/8-16 X 6 1/2" Hex Head Grade 5		3
24	048560	Shaft, Fixed Mount		1
25	F05007-78	Bolt, 3/8-16 x 1 1/2" Hex Head Grade 5		2
26	F05007-88	Screw, 3/8-16x1 Scoket Head Set Brass Tip		2
27	F05010-29	Nut, 3/8-16 Jam		2
28	F05007-17	Bolt, 3/8-16 x 1 1/2" Hex Head Full Thread		2
29	049133	Plate, Scale Mount		1
30	F05006-102	Bolt, 5/16-18 x 3/4" Hex Head		2
31	F05011-13	Washer, 5/16" Split Lock		2
32	F05011-17	Washer, 5/16" SAE Flat		2
33	062516	Box Weldment, LT35 Mast		1
34	F05007-19	Bolt, 3/8-16 x 1 3/4" Hex Head Full Thread		1
35	F05007-64	Screw, 3/8-16 x 1" Zinc & Bake FSHC		1

## 6.2 Up/Down Assembly

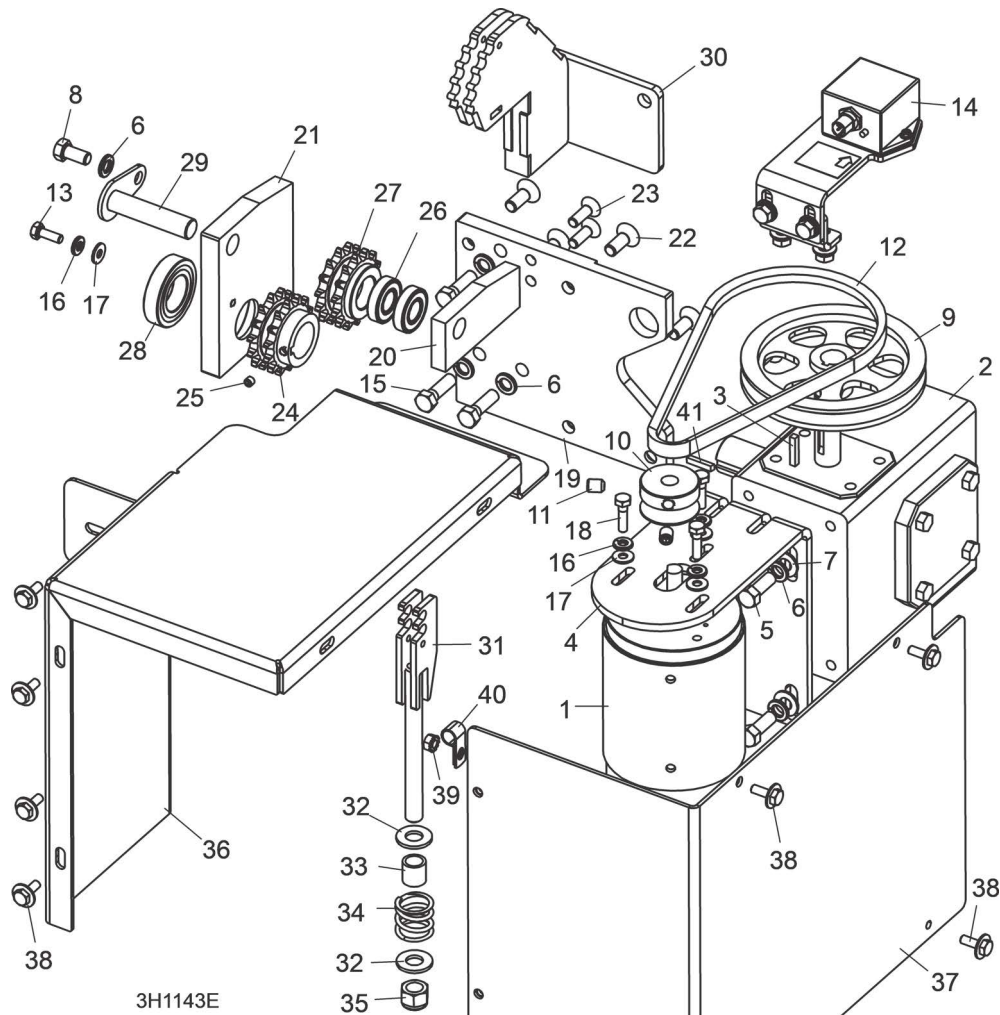

REF	PART #	DESCRIPTION	COMMENTS	QTY.
	062515	<b>MAST ASSEMBLY, LT35</b>		1
	066799	Up/Down Assembly, LT35		1
<b>1</b>	006747	Motor, 1/2HP 12VDC		1
	061794	Brush Kit, 12V Motor		1
<b>2</b>	074166	Gear Box, Up/Down Grove		1
	076149	Gear Box, Up/Down Grove		1
	L04869-3	Gear Oil, ISO 460 Synthetic Bulk		1
<b>3</b>	S31027	Key, 3/16" x 1" Square		1
<b>4</b>	008721	Bracket, Up/Down Motor 3/4HP		1
<b>5</b>	F05007-7	Bolt, 3/8-16 x 1" Hex Head Cap		4
<b>6</b>	F05011-4	Washer, 3/8" Split Lock		8
<b>7</b>	F05011-3	Washer, 3/8" SAE Flat		4
<b>8</b>	F05007-118	Bolt, 3/8-16 x 3/4" Hex Head Grade 5		1
<b>9</b>	066781	Sheave, 5.45 OD 3/4 Bore 4L		1
<b>10</b>	S09579	Sheave, 1 3/4" Feed Motor		1
<b>11</b>	F05007-12	Screw, 3/8-16 x 1/2" SH Cup Pt Set		2
<b>12</b>	038459	Belt, 4L245 Notched		1
<b>13</b>	F05005-1	Bolt, 1/4-20 x 3/4" Full Thread HHCap		1

REF	PART #	DESCRIPTION	COMMENTS	QTY.
14		Magnetic Position Sensor Parts	<i>(See Section 6.3)</i>	
15	F05007-123	Bolt, 3/8-16 x 1 1/4" Hex Head Grade 5		3
16	F05011-14	Washer, 1/4" Split Lock		4
17	F05011-11	Washer, 1/4" SAE Flat		4
18	F05005-38	Screw, 1/4-20 x 1" Hex Head Cap		3
19	066797	Plate, LT35 Up/Down Mounting		1
20	066789	Plate, Up/Down Sprocket Support		1
21	066795	Plate, Up/Down Bearing Mount		1
22	F05007-64	Screw, 3/8-16 x 1" Zinc & Bake FSHC		5
23	F05006-22	Bolt, 5/16-18 x 1" FHS		2
24	066794	Sprocket, D40B14 x 1-1/8" Keyed Bore		1
25	F05005-131	Screw, 1/4-20 x 1/4" SH Cup Pt Set		1
	074932	Sprocket Assembly, D40B14 Idler		1
26	074931	Bearing, 6202-16mm-2RLD		2
27	074930	Sprocket, D40B14x1.376 Bore		1
28	066798	Bearing, 1-1/8 Bore R18-2Rs		1
29	066783	Pin Weldment, 5/8" x 2 3/4"		1
30	062526	Mount Weldment, LT35 Upper Chain		1
	062527	Tensioner Assembly, LT35 Up/Down Chain		1
31	062528	Tensioner Weldment, LT35 Up/Down Chain		1
32	F05011-2	Washer, 1/2" SAE Flat		2
33	016515	Spacer, Up/Down Chain Tensioner		1
34	016516	Spring, 1" OD x 1" Long x .125 Wire Comp		1
35	F05010-8	Nut, 1/2-13 Hex Nylon Lock		1
	074022	Chain, Double #40x 117 Pitches(58-1/2")		1
	017724	Link, #40 Double, Connecting		2
36	076152	<b>GUARD WELDMENT, LT35 UP/DOWN</b>		1
37	076153	<b>COVER WELDMENT, LT35 UP/DOWN GUARD</b>		1
38	F05005-134	<b>BOLT, 1/4-20 X 1/2" HEX HEAD</b>		7
39	F05010-9	<b>NUT, 1/4-20 KEPS</b>		1
40	P07584	<b>CLAMP, 1/2EMT COATED</b>		1
41	S04124	<b>KEY, 1/4" X 1 11/16"</b>		1

### 6.3 Magnetic Position Sensor Assembly

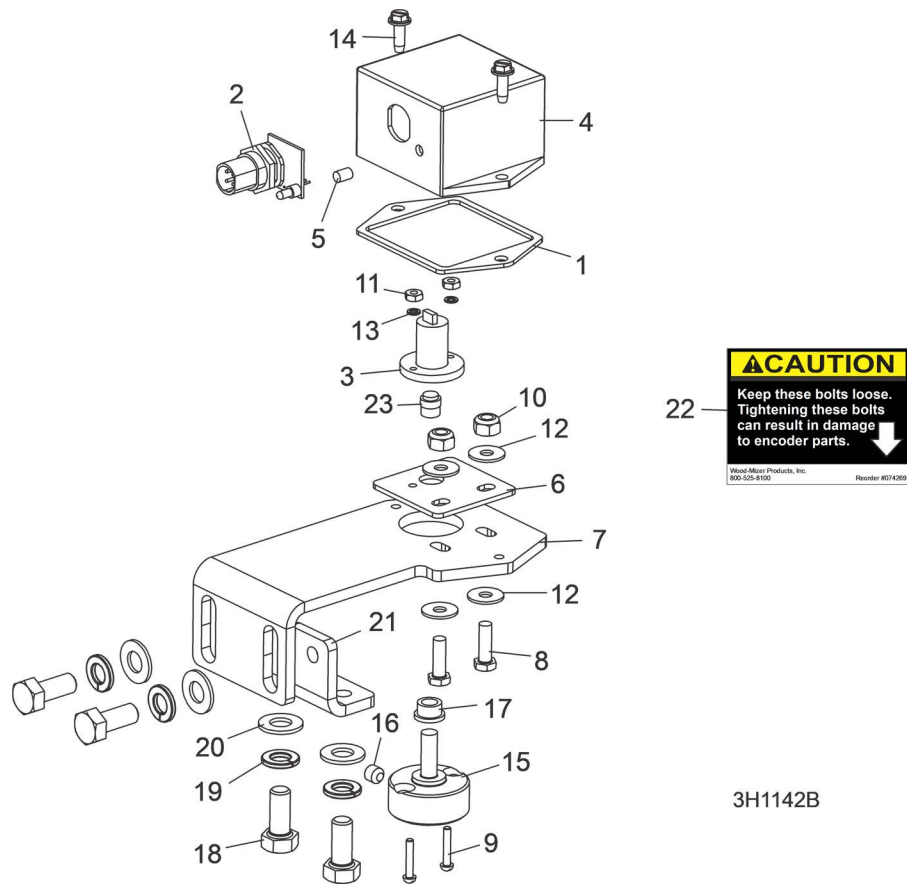

3H1142B

REF	PART #	DESCRIPTION	COMMENTS	QTY.
	053369	<b>SENSOR ASSEMBLY, MAGNETIC POSITION</b>		1
1	006864	Gasket, Encoder		1
2	053376	PCB Assembly, Encoder Sensor	Available in assemblies only.	1
3	053387	Sensor Kit, Magnetic Encoder		1
4	053399	Enclosure, Position Sensor		1
5	053400	Lens, LED T1 Clear		1
6	057853	Plate, SimpleSet Encoder Slide		1
7	061518	Plate, SimpleSet Encoder Mount		1
8	F05004-18	Screw, 10-24 x 5/8" Unsl Indent Hex Head Machine		2
9	F05004-49	Screw, #4-40 x 5/8" Sl Rnd Head Machine		2
10	F05010-160	Nut, 10-24 Hex Nylock		2
11	F05010-43	Nut, #4-40 Hex		2
12	F05011-18	Washer, #10 SAE Flat		4
13	F05011-21	Washer, #4 Split Lock		2
14	F05015-18	Bolt, #8-32 x 1/2" Sl Hex Head S		2
15	057852	Extension, SimpleSet Gearbox Shaft		1
16	F05005-131	Screw, 1/4-20 x 1/4" SH Cup Pt Set		1
17	049018	Bushing, Flange 1/4" ID x 1/4" Lg		1
18	F05006-5	Bolt, 5/16-18 x 3/4" Hex Head Cap		4

**6** **Up/Down System**  
*Magnetic Position Sensor Assembly*

---

REF	PART #	DESCRIPTION	COMMENTS	QTY.
19	F05011-13	Washer, 5/16" Split Lock		4
20	F05011-17	Washer, 5/16" SAE Flat		4
21	057872	Plate, SimpleSet Mount		1
22	074269	Decal, Encoder Bolt Warning		1
23	065890	Magnet Assembly, Simple Set Encoder w/Hub		1



## SECTION 7 FEED SYSTEM & TRACK ROLLERS

### 7.1 Track Rollers And Wipers

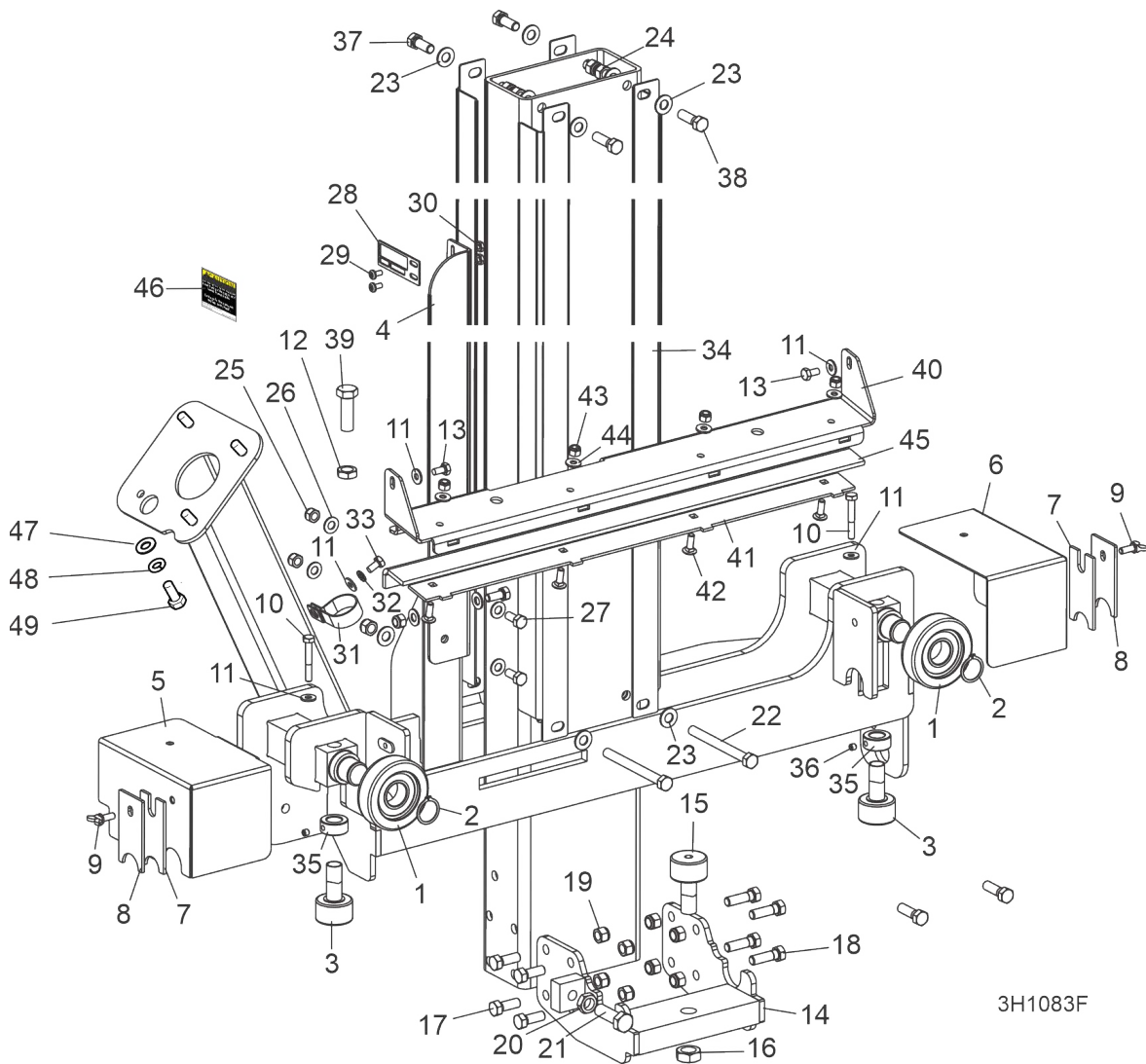

3H1083F

REF	PART #	DESCRIPTION	COMMENTS	QTY.
	062514	<b>UPRIGHT ASSEMBLY, LT35</b>		1
1	023857	Bearing, MG305DDA		2
2	F04254-15	Ring, 1" Outer Retaining		2
3	012797	Bearing, Cam Follower 1 1/2" (McGill)		2
4	062537	Plate, LT35 Pointer Mount		1
5	049342	Cover Weldment, Rear Bearing		1
6	049341	Cover Weldment, Front Bearing		1
7	M04113	Wiper, Top Rail		2
8	034229	Plate, Track Wiper		2
9	F05005-64	Stud, 1/4-20 x 5/8" Wing		2
10	F05005-68	Bolt, 1/4-20 x 1 3/4" Hex Head Grade 5		2
11	F05011-11	Washer, 1/4" SAE Flat		5
12	F05010-31	Nut, 1/2-13 Jam		1
13	F05005-137	Bolt, 1/4-20x5/8 HH Gr5		2

REF	PART #	DESCRIPTION	COMMENTS	QTY.
	048547	Bearing Assembly, Lower LT28		1
14	048548	Bearing Weldment, LT28 Lower Cam		1
15	012797	Bearing, Cam Follower 1 1/2 (McGill)		1
16	F05010-11	Nut, 5/8-18 Hex Jam		1
17	F05007-87	Bolt, 3/8-16 x 1" Hex Head Grade 5		4
18	F05007-123	Bolt, 3/8-16 x 1 1/4" Hex Head Grade 5		4
19	F05010-10	Nut, 3/8-16 Hex Nylon Lock		8
20	F05010-31	Nut, 1/2-13 Hex Jam		1
21	F05008-33	Bolt, 1/2-13 x 1 1/2" Hex Head Grade 5		1
22	F05007-92	Bolt, 3/8-16 x 4" Hex Head Full Thread Grade 5		2
23	F05011-3	Washer, 3/8" SAE Flat		12
24	F05010-10	Nut, 3/8-16 Hex Nylon Lock		10
25	F05010-58	Nut, 5/16-18 Nylok Hex		3
26	F05011-17	Washer, 5/16" SAE Flat		6
27	F05006-5	Bolt, 5/16-18 x 3/4" Hex Head		3
28	017778	Pointer, Scale Height		1
29	F05004-3	Bolt, #10-24 x 3/8" CrSI PH		2
30	F05010-14	Nut, #10-24 Keps		2
31	038482	Clamp, 1-1/4 Carbon Steel Conduit		1
32	F05011-14	Washer, 1/4" Split Lock		1
33	F05005-15	Bolt, 1/4-20 x 1/2" Hex Head		1
34	048614	Angle, LT28 Mast Tube Stainless		4
	P05035	Collar, 5/8" x 1-1/8" Lock		2
35	P05035-1	Collar, 5/8" x 1-1/8" Lock		1
36	F05005-105	Screw, 1/4-28 x 1/4" BO SH Cup Set		1
37	F05007-87	Bolt, 3/8-16 x 1" Hex Head Grade 5		2
38	F05007-123	Bolt, 3/8-16 x 1 1/4" Hex Head Grade 5		2
39	F05008-33	Bolt, 1/2-13 x 1 1/2" Hex Head Grade 5		1
	110614	Cover Assembly, LT28/35/70 Track		1
40	110610	Cover, Mid Track, LT28, LT35, LT70		1
41	110611	Retainer, Felt Oiler		1
42	F05005-113	Bolt, 1/4-20x3/4 Carriage		4
43	F05010-69	Nut, 1/4-20 Nylock		4
44	F05011-11	Washer, 1/4 SAE Flat		4
45	S09915	Felt, Middle Track Oiler LT40/50/70		1
46	S11762	<b>DECAL, SAW HEAD UP/DOWN CAUTION</b>		1
47	F05011-17	Washer, 5/16 SAE Flat		4
48	F05011-13	Washer, 5/16 Split Lock		4
49	F05006-53	Bolt, 5/16-18x5/8 HH Gr2		4

## 7.2 Power Feed Assembly

LT35 Rev. A4.00+  
LT35HD Rev. A4.00+

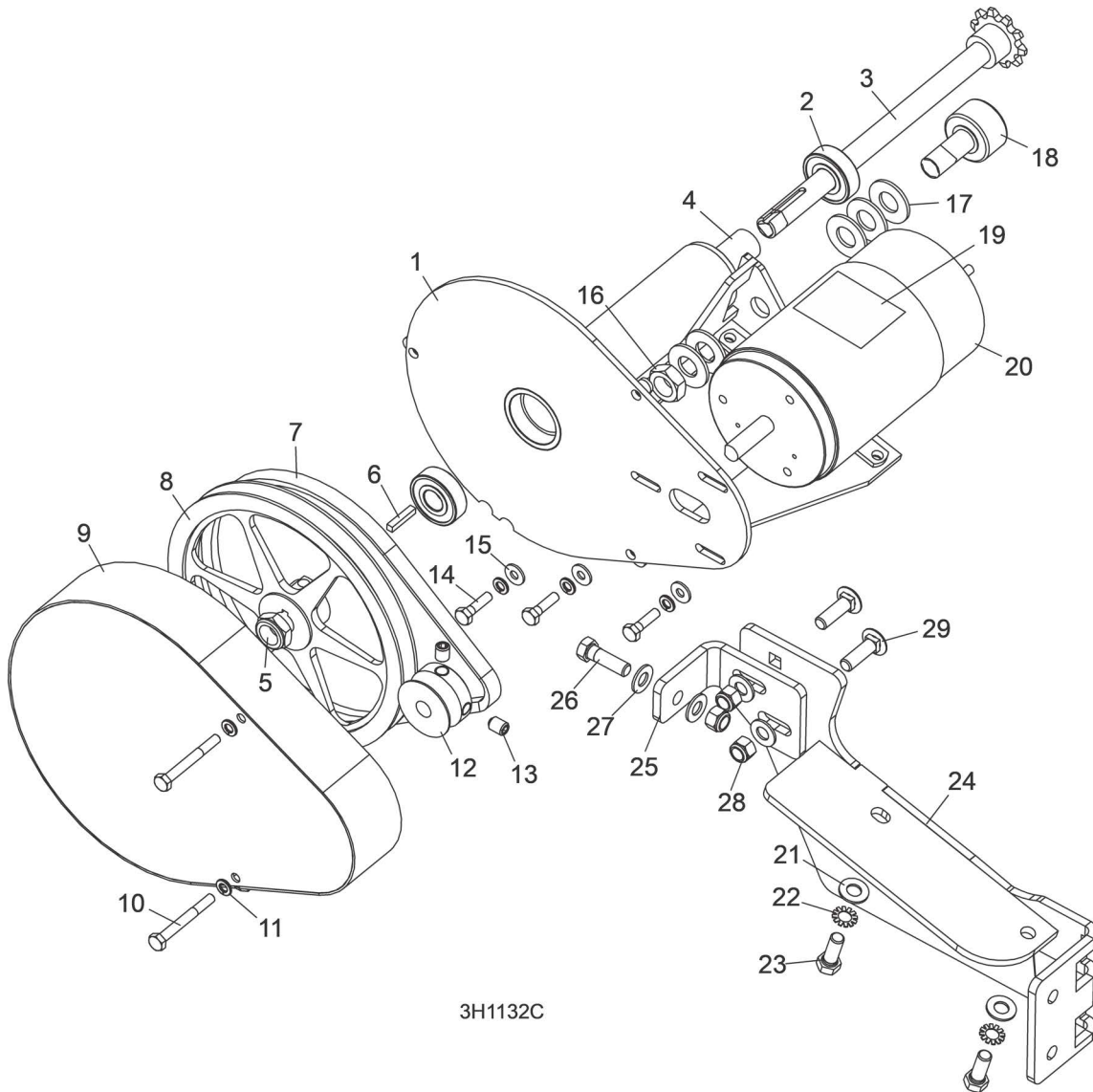

3H1132C

REF	PART #	DESCRIPTION	COMMENTS	QTY.
	066999	<b>POWER FEED ASSEMBLY, LT35</b>		1
	066990	Feed Assembly, LT35 Saw Head Power		1
1	066991	Mount Weldment, LT35 Power Feed		1
2	P06030-1	Bearing, 5/8" x 1.5748 x .4724		2
	079800	Shaft Upgrade, Power Feed		1
3	079798	Shaft Weldment, Power Feed, Threaded	Available in assemblies only.	1
4	079799	Spacer, Bearing, Power Feed		1
5	F05010-101	Nut, 5/8-18 Nyl Jam		1
6	S31027	Key, 3/16" Square x 1" Long		1
7	P04031	Belt, 4L280		1
8	P04343	Sheave, 8A x 5/8"		1
9	W11613	Cover Weldment, Power Feed		1

REF	PART #	DESCRIPTION	COMMENTS	QTY.
10	F05005-32	Screw, 1/4-20 x 2 1/4" Hex Head		2
11	F05011-14	Washer, 1/4" Split Lock		5
12	S09579	Shave, 1 3/4" Feed Motor		1
13	F05007-12	Screw, 3/8-16 x 1/2" SH Cup		2
14	F05005-101	Bolt, 1/4-20 x 1" Hex Head Grade 5		1
15	F05011-11	Washer, 1/4" SAE Flat		3
16	F05010-11	Nut, 5/8-18 Hex Jam		1
17	F05011-5	Washer, 5/8" SAE Flat		6
18	012797	Bearing, Cam Follower 1 1/2"		1
19	024431	Decal, Disconnect Motor Leads Warning		1
20	006747	Motor, 1/2HP 12VDC		1
	061794	Brush Kit, 12V Motor		1
21	F05011-3	Washer, 3/8" Sae Flat		2
22	F05011-36	Washer, 3/8" Star External		2
23	F05007-82	Bolt, 3/8-16 x 1" Hex Head Grade 8		2
24	066995	Mount Weldment, Power Feed Motor		1
25	066998	Plate, Power Feed Drive		1
26	F05007-123	Bolt, 3/8-16 x 1 1/4" Hex Head Grade 5		1
27	F05011-3	Washer, 3/8" Sae Flat		4
28	F05010-10	Nut, 3/8-16 Hex Nylon Lock		3
29	F05007-127	Bolt, 3/8-16 x 1 1/4" Carriage Head Grade 5		2

### 7.3 Feed Chain/Stop

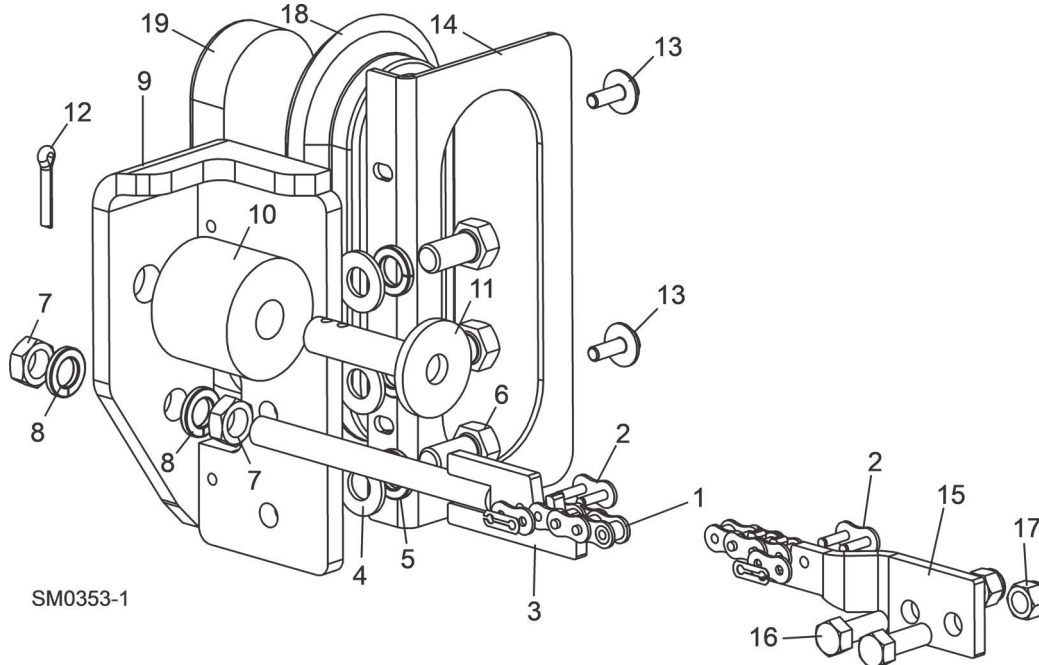

REF	PART #	DESCRIPTION	COMMENTS	QTY.
1	014745	CHAIN, #40 X 267.5" LT40 FEED		1
2	P04200	LINK, #40 MASTER		2
3	015721	TENSIONER WELDMENT, POWER FEED CHAIN		1
4	F05011-2	WASHER, 1/2" SAE FLAT		3
5	F05011-9	WASHER, 1/2" SPLIT LOCK		3
6	F05008-128	BOLT, 1/2-13 X 1" HEX HEAD GRADE 8		3
7	F05010-16	NUT, 1/2-20 HEX JAM		2
8	F05011-9	WASHER, 1/2" SPLIT LOCK		2
9	006686	BRACKET WELDMENT, REAR FEED STOP		1
	K09630	STOP KIT, RUBBER CARRIAGE		2
10	P12165	Stop, Rubber Carriage		1
11	W09293	Pin, Rubber Carriage Stop		1
12	F05012-21	Pin, 3/16" X 1" Cotter		1
13	F05005-134	BOLT, 1/4-20 X 3/4" WITH CONICAL WASHER		1
14	057822	PLATE, BED TUBE END W/LIGHT MOUNT		1
15	015008	BRACKET, FRONT FEED CHAIN MOUNT		1
16	F05007-87	BOLT, 3/8-16 X 1" HEX HEAD GRADE 5		2
17	F05010-10	NUT, 3/8-16 HEX NYLON LOCK		2
18	006688	GROMMET, 6 1/2" LIGHT MOUNTING		1
19	006391	LIGHT, 8 DIODE LED TAIL		1

## SECTION 8 BED FRAME ASSEMBLY

### 8.1 Bed Rail Assembly, Front And Rear

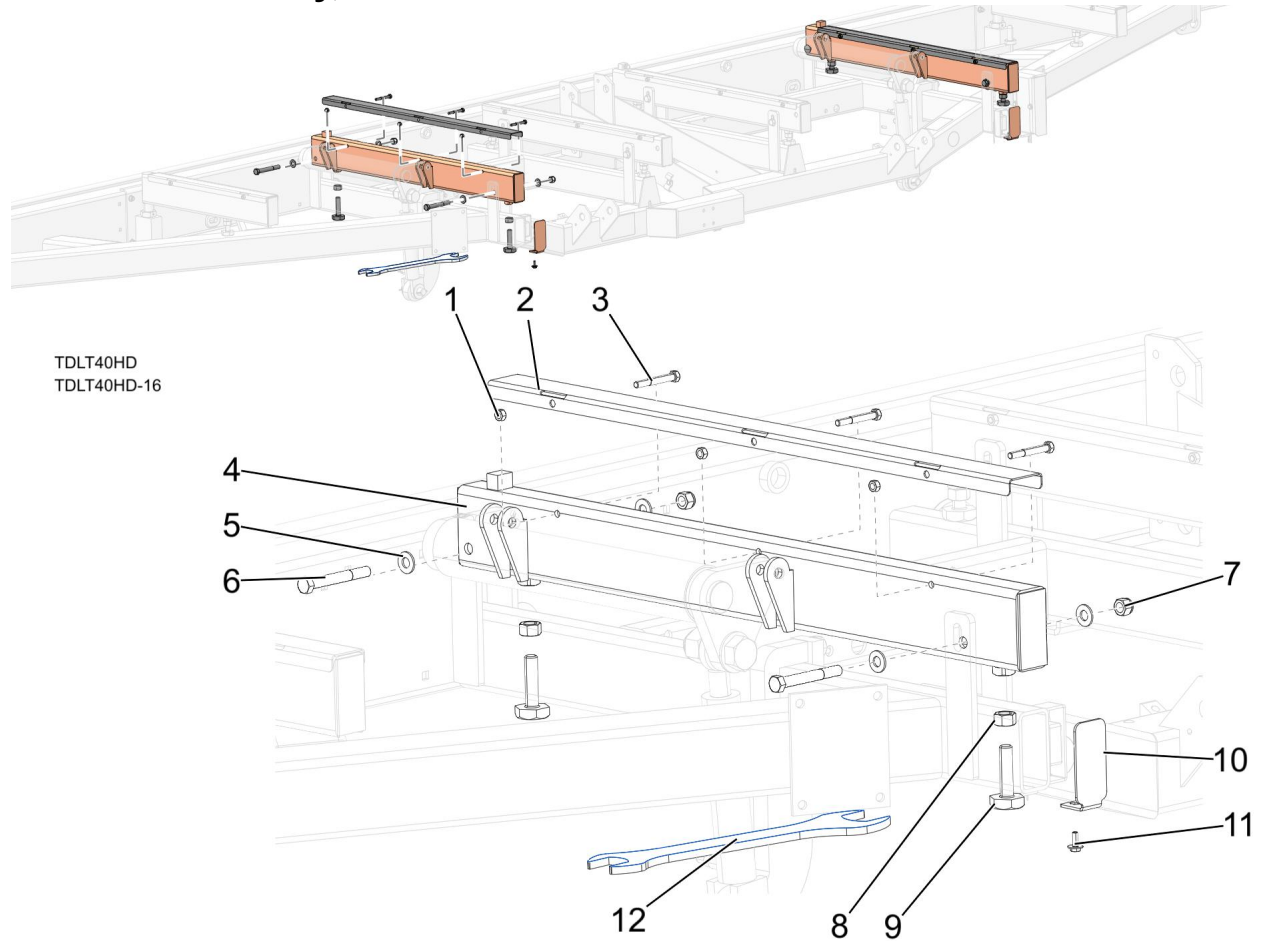

REF	PART #	DESCRIPTION	COMMENTS	QTY.
	079144	Kit, Front/Rear Bed Rail SS Cover		1
1	F05010-6	Nut, 5/16-18 Swaged Hex		6
2	016898	Cover, 36-1/4 Rail SS		2
3	F05006-10	Bolt, 5/16-18x2 1/2 HH Gr2		6
4	014455	Bedrail Weldment, 1996 Front Hyd	Front	1
	014467	Bedrail Weldment, 1996 Rear Hyd	Rear	
5	F05011-2	Washer, 1/2 SAE Flat		7
6	F05008-78	Bolt, 1/2-13 x 4 HHB GR5 ZINC	Front	3
	F05008-94	Bolt, 1/2-13x3 1/2 Carriage	Rear	
7	F05010-8	Nut, 1/2-13 Nyl Hex Lock		4
8	F05010-5	Nut, 5/8-11 Hex		4
9	S13006	Bolt, Bed Rail Adj LT50		4
10	038843	Plate, Formed 2x4 Bed Cap		1
11	F05005-134	Bolt, 1/4-20x3/4 W/Conical Washer		1
12	015970	Wrench, Bed Rail Adjustment	<b>OPTIONAL</b>	1

## 8.2 Bed Rail Assembly, Middle Front

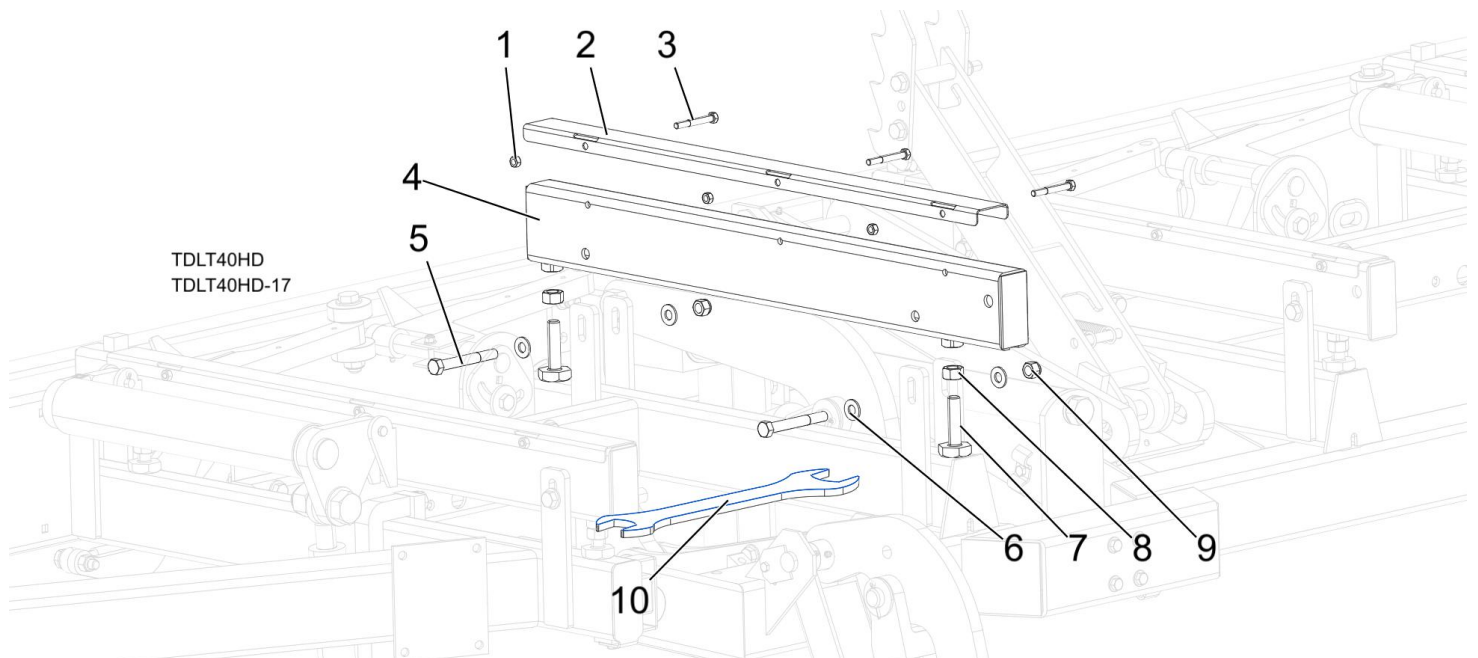

REF	PART #	DESCRIPTION	COMMENTS	QTY.
	079144	Kit, Front/Rear Bed Rail SS Cover		1
1	F05010-6	Nut, 5/16-18 Swaged Hex		3
2	S09944	Cover, 33 Rail SS		1
3	F05006-10	Bolt, 5/16-18x2 1/2 HH Gr2		3
4	034545	Tube Weldment, Bed Rail 2		1
5	F05008-78	Bolt, 1/2-13 x 4 HHB GR5 ZINC		2
6	F05011-2	Washer, 1/2 SAE Flat		4
7	S13006	Bolt, Bed Rail Adj LT50		2
8	F05010-5	Nut, 5/8-11 Hex		2
9	F05010-8	Nut, 1/2-13 Nyl Hex Lock		2
10	015970	Wrench, Bed Rail Adjustment	<b>OPTIONAL</b>	1

### 8.3 Bed Rail Assembly, Middle Rear

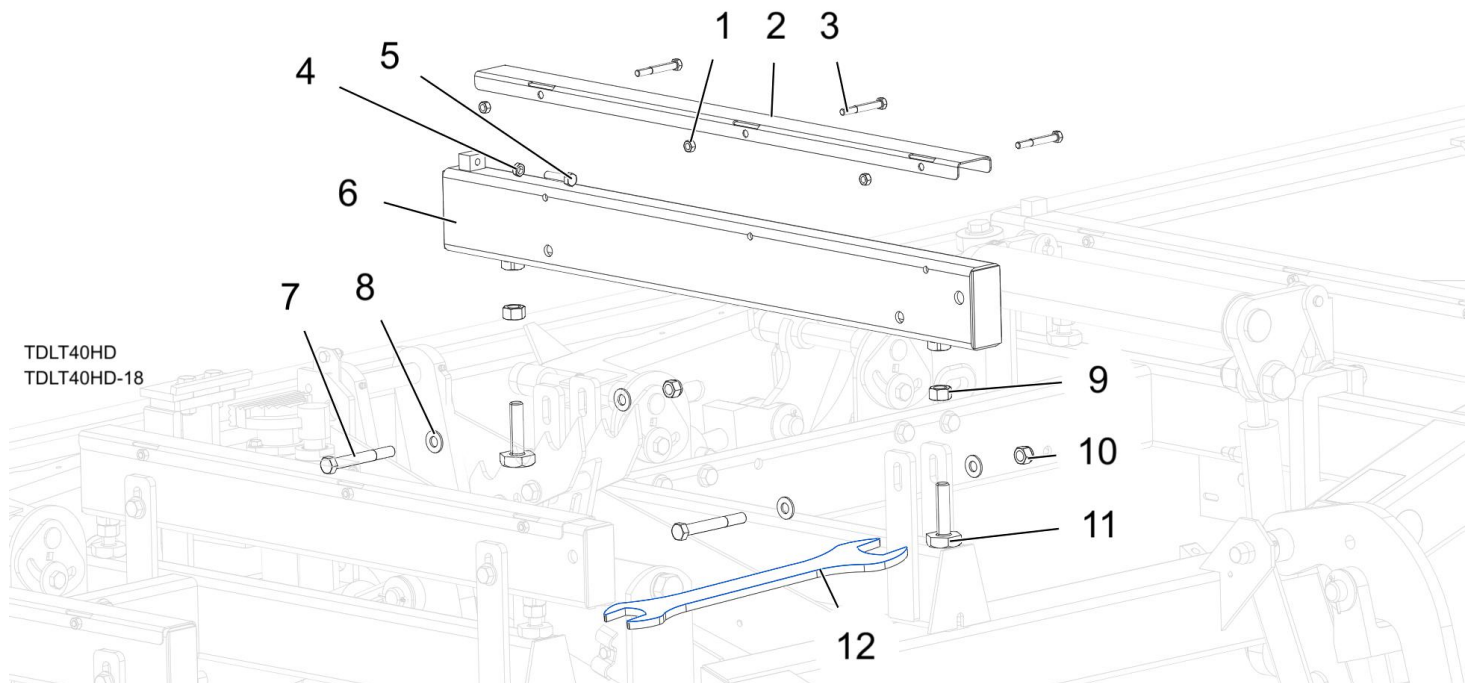

REF	PART #	DESCRIPTION	COMMENTS	QTY.
	079144	Kit, Front/Rear Bed Rail SS Cover		1
1	F05010-6	Nut, 5/16-18 Swaged Hex		3
2	S09944	Cover, 33 Rail SS		1
3	F05006-10	Bolt, 5/16-18x2 1/2 HH Gr2		3
4	F05010-29	Nut, 3/8-16 Jam		1
5	F05007-17	Bolt, 3/8-16 x 1 1/2 HH FT Znc		1
6	015757	Bedrail Assembly, Rear Middle Hyd.		1
7	F05008-78	1/2-13 x 4 HHB GR5 ZINC		2
8	F05011-2	Washer, 1/2 SAE Flat		4
9	F05010-5	Nut, 5/8-11 Hex		2
10	F05010-8	Nut, 1/2-13 Nyl Hex Lock		2
11	S13006	Bolt, Bed Rail Adj LT50		2
12	015970	Wrench, Bed Rail Adjustment	<b>OPTIONAL</b>	1



## 8.4 Pivot Bed Rail Assembly

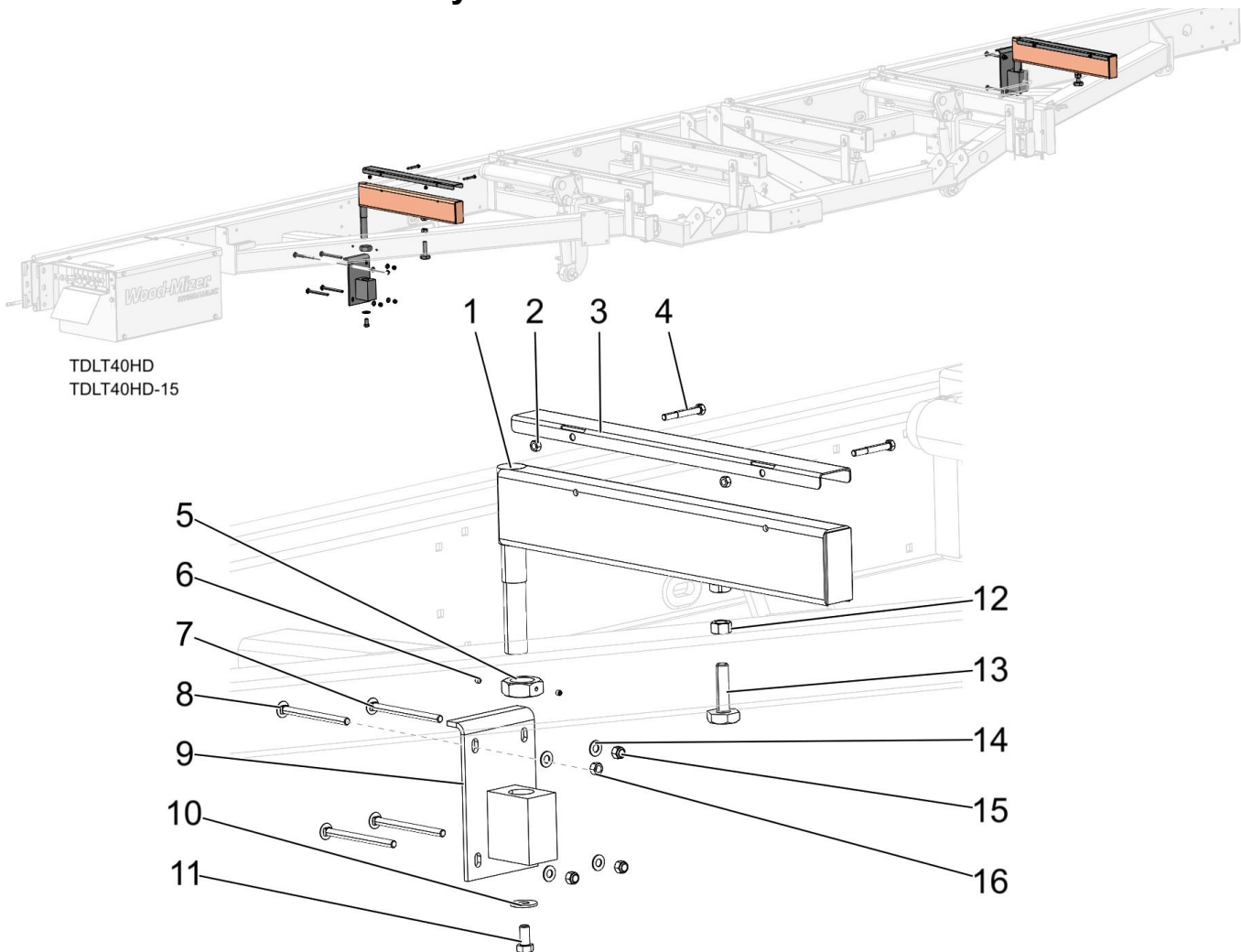

TDLT40HD  
TDLT40HD-15

REF	PART #	DESCRIPTION	COMMENTS	QTY.
	A13015	Rail, Front Pivot Assembly	Front and Rear are the same	1
	A13015-R	Rail, Rear Pivot Assembly		1
1	W13014	Pivot Weldment, Long Bed Rail		1
2	F05010-6	Nut, 5/16-18 Swaged Hex		2
3	S13012	Cover, 22.75 SS LT50 Pivot		1
4	F05006-10	Bolt, 5/16-18x2 1/2 HH Gr2		2
5	F05010-100	Nut, 1 1/4-12 Jam		1
6	F05005-42	Screw, 1/4-28x1/4 Brass Tip		2
7	F05007-113	Bolt, 3/8-16x5 Carriage		3
8	F05007-114	Bolt, 3/8-16x4 3/4 Carriage		1
9	W13090	Mount Weldment, Pivot Bed Rail		1
10	F05011-52	WASHER, 9/16 FLAT ZINC		1
11	F05008-50	Bolt, 1/2-13x1 HH Gr2		1
12	F05010-5	Nut, 5/8-11 Hex		1
13	S13006	Bolt, Bed Rail Adj LT50		1
14	F05011-3	Washer, 3/8 Flat SAE		4
15	F05010-10	Nut, 3/8-16 Hex Nyl Lock		3
16	F05010-25	Nut, 3/8-16 Swaged		2

## 8.5 Log Side Support Assembly (Manual)

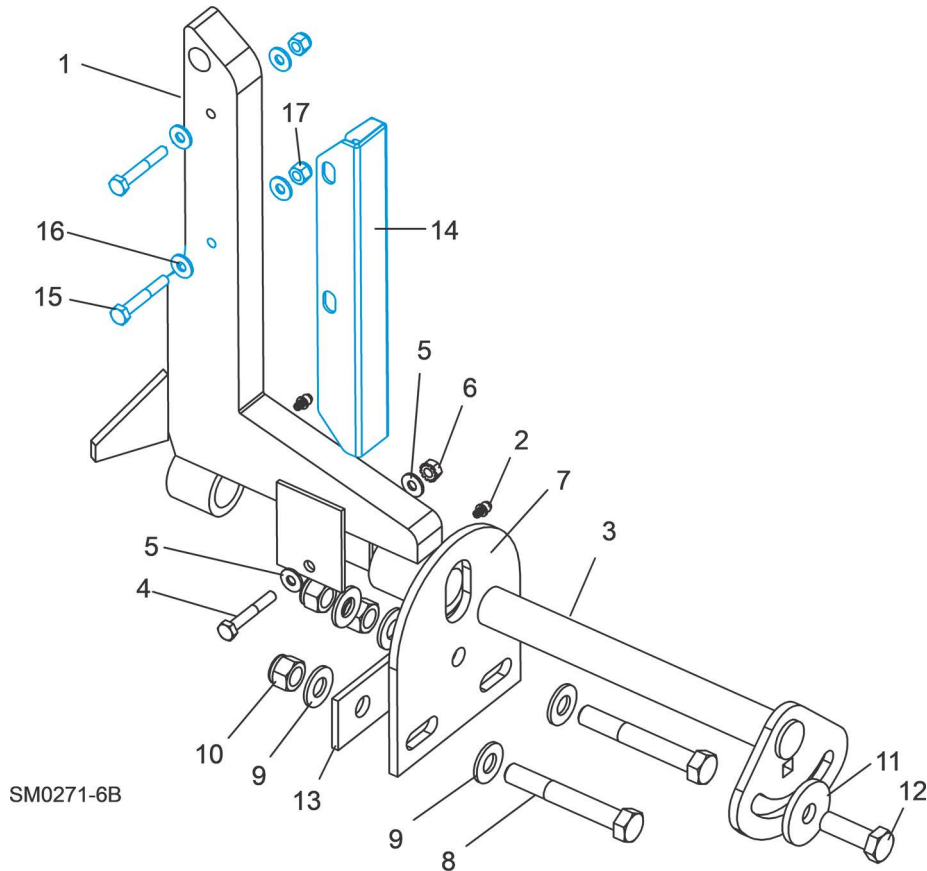

REF	PART #	DESCRIPTION	COMMENTS	QTY.
	034554	Support Assembly, Side, Manual		
1	015235	Support, Log Side		2
2	P04107	Fitting, 3/16" Grease		2
3	016544	Pin, Log Side Support Pivot		1
4	F05005-4	Bolt, 1/4-20 X 1 1/2" Hex Head Grade 5		1
5	F05011-11	Washer, 1/4" SAE Flat		2
6	F05010-9	Nut, 1/4-20 Self Locking		1
7	016555	Plate, Log Side Support End		1
8	F05008-61	Bolt, 1/2-13 X 3 1/2" Hex Head Grade 5		2
9	F05011-2	Washer, 1/2" SAE Flat		5
10	F05010-8	Nut, 1/2-13 Hex Nylon Lock		3
11	014632	Washer, .52" x 1.69"		1
12	F05008-33	Bolt, 1/2-13 X 1 1/2" Hex Head Grade 5		1
13	016558	Plate, Side Support Washer Clamp		1
	016562	Roller Kit, Side Support		4
	016798	Guard Kit, Stainless Steel Side Support	<b>(OPTIONAL)</b>	1
14	016722	Guard, Stainless Steel Side Support		4
15	F05005-4	Bolt, 1/4-20 x 1 3/4" Hex Head		8
16	F05011-11	Washer, 1/4" SAE Flat		16
	F05011-5	Washer, 5/8" SAE Flat	For extra spacing on the hydraulic supports	4
17	F05010-69	Nut, 1/4-20 Hex Nylon Lock		8
	016798-1005	Instruction Sheet,		1

## 8.6 Transport Safety Chain and Rest Pin

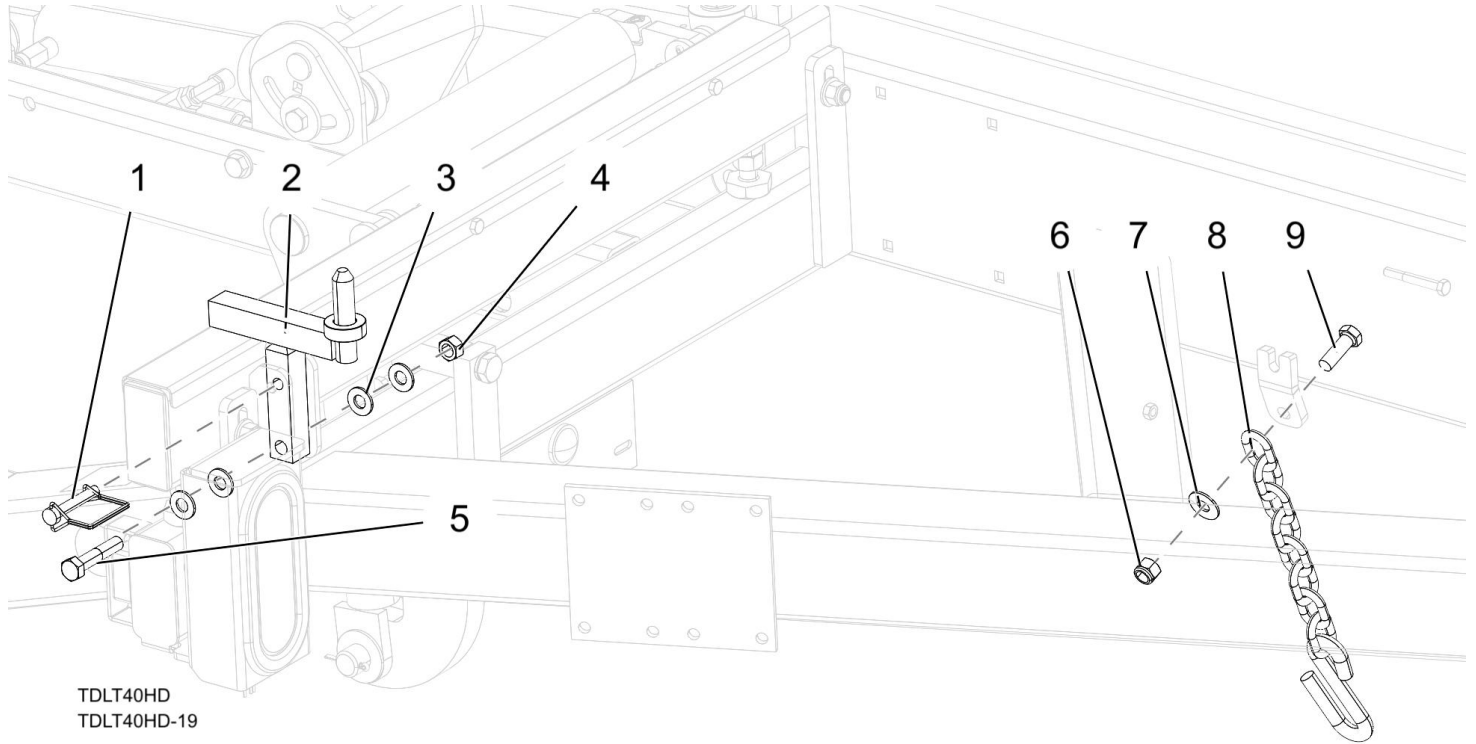

TDLT40HD  
 TDLT40HD-19

REF	PART #	DESCRIPTION	COMMENTS	QTY.
	079485	Pin Assy, Rest, 40/50		1
	079511	Pin Assy, Rest, 40/50 Hyd Wide		
1	014151	Pin, 3/8x2 1/4 SQ Wire Lock		1
2	014102	Pin Wldmt, C-Frame Rest 96 Hyd		1
	079510	Pin Wldmt, Rest, 40/50 Hyd Wide		
3	F05011-2	Washer, 1/2 SAE Flat		4
4	F05010-3	Nut, 1/2-13 Swaged Hex		1
5	F05008-74	Bolt, Hex Head 1/2-13x2 1/2 Gr5 Zinc		1
6	F05010-8	Nut, 1/2-13 Nyl Hex Lock		1
7	F05011-35	Washer, 7/16 Standard Flat		1
8	107972	Chain, 15 Inch Safety		1
9	F05008-33	Bolt, 1/2-13x1 1/2 HH Gr5		1

## 8.7 Bed Frame Decals

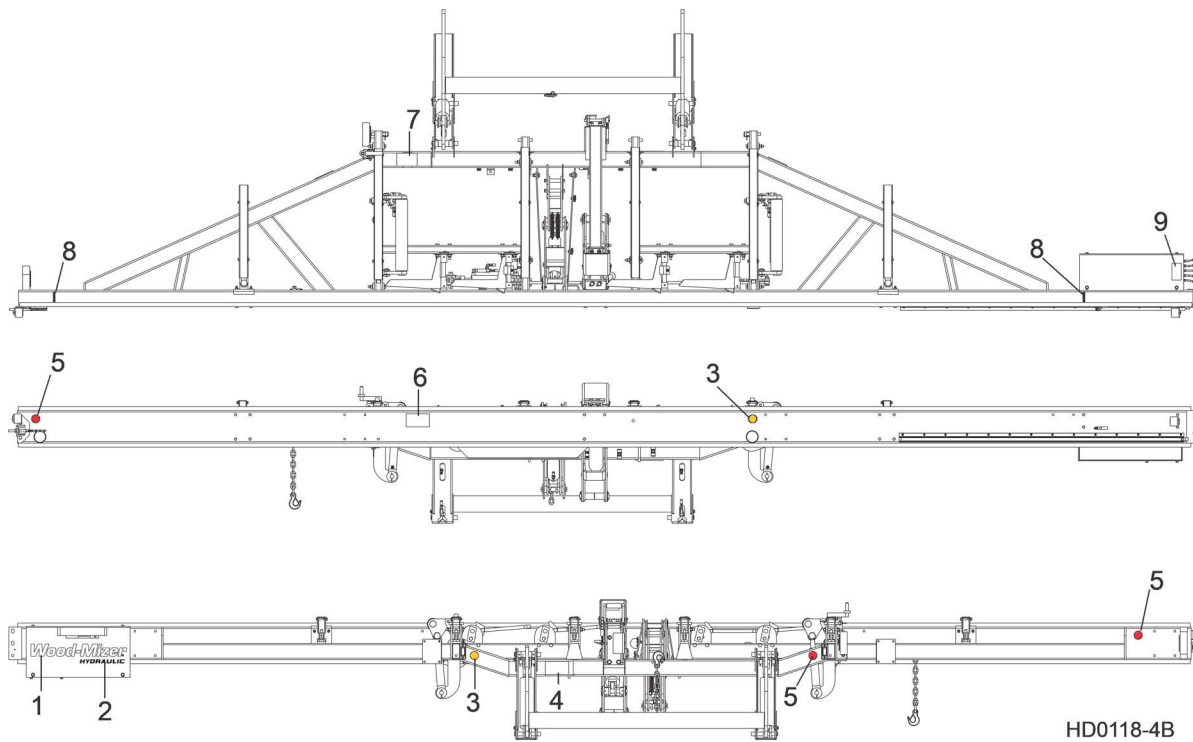

REF	PART #	DESCRIPTION	COMMENTS	QTY.
1	065034	DECAL, WHITE WOOD-MIZER EURO LOGO		1
2	065035	DECAL, HYDRAULIC EURO LOGO BLACK	For standard hydraulic mills	1
	065036	DECAL, HYDRAULIC EURO LOGO BLACK	For super hydraulic mills	1
3	P07453	DECAL, AMBER REFLECTIVE 2" ROUND		2
4	S09851	DECAL, KEEP AWAY DANGER		1
5	P07452	DECAL, RED REFLECTIVE 2" ROUND		3
6	P10287	DECAL, PINCH POINT DANGER		1
7	S12581	DECAL, SAW HEAD REST CAUTION		1
8	S12051	DECAL, LOG LIMIT STRIPE		2
9	P12961	DECAL, KEEP AWAY HYDRAULIC WARNING		1

## 8.8 Board Outfeed Table (Optional)

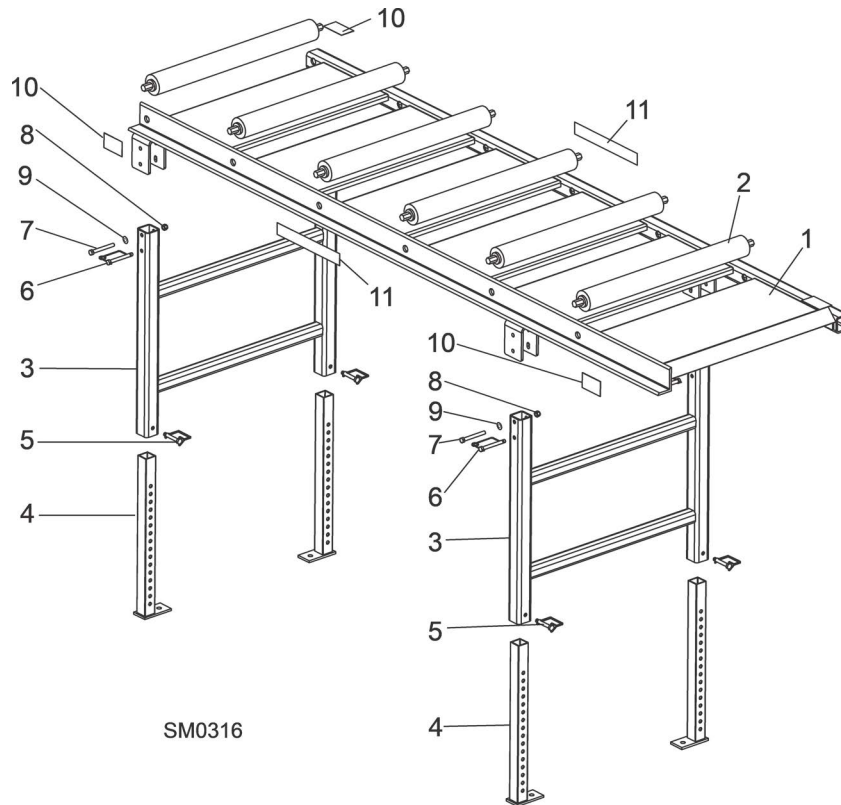

REF	PART #	DESCRIPTION	COMMENTS	QTY.
	016652	<b>TABLE ASSEMBLY, BOARD OUTFEED</b>		1
<b>1</b>	016606	Table Weldment, Board Outfeed		1
<b>2</b>	038167	Roller, 2 1/2" x 25"		6
<b>3</b>	016609	Mount Weldment, Outfeed Table Leg		2
<b>4</b>	016651	Leg Weldment, Outfeed Table		4
<b>5</b>	014151	Pin, 3/8" x 2 1/4" Square Wire Lock		4
<b>6</b>	016677	Pin, Snap - Coil Tension		4
<b>7</b>	F05004-123	Bolt, 3/8-16x3 1/2 HH Gr5		4
<b>8</b>	F05010-222	Nut, 3/8-16 Flanged Hex Nylock		4
<b>9</b>	F05011-3	Washer, 3/8 Flat SAE		4
<b>10</b>	S12641	Decal, Hand Pinch Point Warning		4
<b>11</b>	015882	Decal, Wood-Mizer Logo 10.25"		2

## SECTION 9 BED HYDRAULIC SYSTEM

### 9.1 Hydraulic Hoses

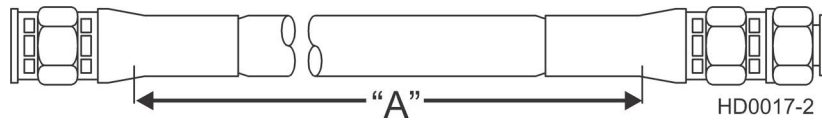

REF	COLOR	LENGTH "A"		DESCRIPTION (NOTE: See Hydraulic Information Section in Operator's Manual for Hydraulic Schematics)	PART #	QTY.
		MFG SPEC	ACTUAL PART			
H1	None	9"	9"	1/4" Hydraulic Pump To Valve	079000-9	1
H2	Plain	27"	27"	Log Turner Base	079000-27	1
H3	Orange	18"	18"	Log Turner Top	079000-18	1
H4	Yellow	117"	117"	Front Toe Board Top	079000-117	1
H5	Gray	117"	117"	Front Toe Board Base	079000-117	1
H6	Pink	181"	181"	Side Support Base	079000-181	1
H7	Plain	181"	181"	Side Support Top	079000-181	1
H8	White	155"	157"	Clamp In/Out Top	079000-157	1
H9	Dark Orange	147"	151"	Clamp In/Out Base	079000-151	1
H10	Purple	219"	219"	Rear Toe Board Top	079000-219	1
H11	Black	219"	219"	Rear Toe Board Base	079000-219	1
H12	Green	62"	62"	Loading Arm Branch Top	079000-62	2
H13	Yellow	64"	64"	Loading Arm Branch Base	079000-64	2
H14	Blue	186"	186"	Loading Arm Top	079000-186	1
H15	Red	186"	186"	Loading Arm Bottom	079000-186	1
H16	Green	204"	204"	1/4" Clamp Up/Down Top	079000-204	1
H17	Yellow	193"	194"	1/4" Clamp Up/Down Base	079000-194	1
				Grommet, 2 1/2" Diameter Rubber	085614	2
				Grommet, 1 x 1 3/4" Oval Rubber	085613	2

9.2 Hydraulic Control Box

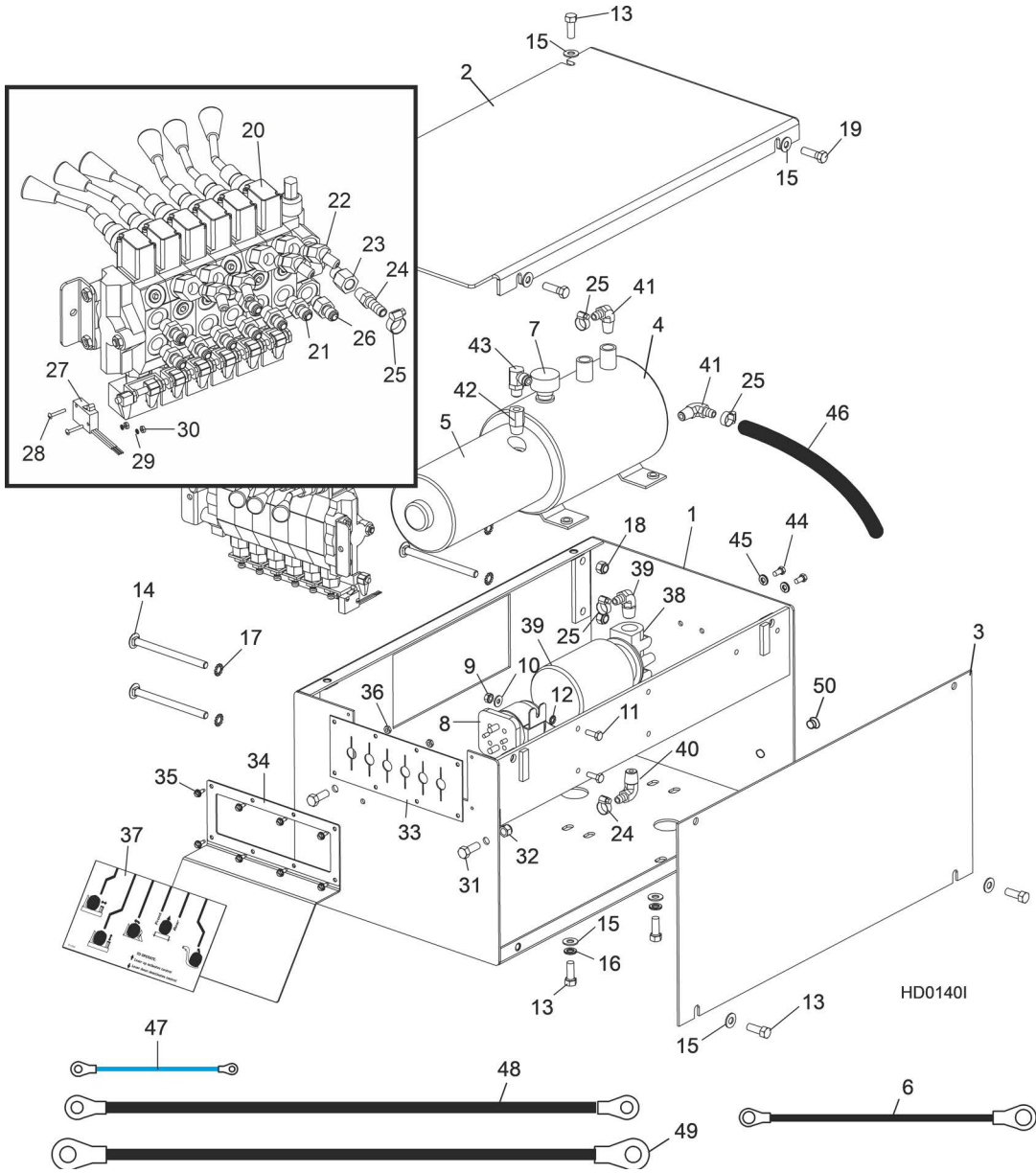

REF	PART #	DESCRIPTION	COMMENTS	QTY.
1	015027	BOX WELDMENT, SUPER HYDRAULIC PUMP HOUSING		1
2	015228	COVER, SUPER HYDRAULIC PUMP HOUSING TOP		1
3	015227	COVER, SUPER HYDRAULIC PUMP HOUSING SIDE		1
4	061764	PUMP KIT, HYDRAULIC W/MOTOR		1
	016199	Pump, Hydraulic Replacement Monarch Model #12070		1
	052807	Motor Kit, Hydraulic Replacement		1
5	038683	Motor, 12 VDC Hydraulic Pump #08714 (Iskra)	Available in assemblies only.	1
	038682	Brush Kit, 4-Valve Hydraulic Pump Motor #08658-I (Iskra)		1
	P12513	Bearing, Base Motor #02318		1

REF	PART #	DESCRIPTION	COMMENTS	QTY.
6	052806	Wire Assembly, Motor Brush Ground		1
7	P12817	Cap, Hydraulic Pump Vented Fill #03171		1
	P10198	O-Ring, Hydraulic Pump/Reservoir #02352		1
	P10315	Seal, Hydraulic Pump/Motor #02330		1
8	016371	<b>SOLENOID KIT, 200A 12V SPST HYDRAULIC PUMP MOTOR</b>		1
	015470	Solenoid, 200A 12V SPST Cont. Duty	Available in assemblies only.	1
	015426	Diode Assembly, Solenoid Coil Chassis Gnd		1
9	F05010-9	<b>NUT, 1/4-20 SELF-LOCKING HEX</b>		2
10	F05011-11	<b>WASHER, 1/4" SAE FLAT</b>		2
11	F05005-1	<b>BOLT, #1/4-20 X 3/4" HEX HEAD FULL THREAD</b>		2
12	F05011-37	<b>WASHER, 1/4" EXTERIOR STAR LOCK</b>		2
	P12742	<b>FLUID, 1-QUART DEXRON III HYDRAULIC</b>		2 1/4 gal.
	006397	<b>FLUID, 1-GALLON CONOCO MV32</b>		2 1/4 gal.
	P12822	<b>FLUID, 1-GALLON EXXON UNIVIS HVI 13HY-DRAULIC</b>		2 1/4 gal.
13	F05007-87	<b>BOLT, 3/8-16 X 1" HEX HEAD GRADE 5</b>		8
14	F05007-113	<b>BOLT, 3/8-16 X 5" CARRIAGE HEAD</b>		4
15	F05011-3	<b>WASHER, 3/8" SAE FLAT</b>		10
16	F05011-4	<b>WASHER, 3/8" SPLIT LOCK</b>		4
17	F05011-36	<b>WASHER, 3/8" EXTERNAL STAR LOCK</b>		4
18	F05010-10	<b>NUT, 3/8-16 HEX NYLON LOCK</b>		4
19	F05007-2	<b>BOLT, 3/8-16 X 1 1/4" HEX HEAD</b>		2
20	015260	<b>VALVE, HYDRAULIC 6 SECTION</b> ( <a href="#">See Form 575</a> For Valve Service Parts)		1
21	P26284	<b>FITTING, 3/8" O-RING - 1/4" JIC</b>		8
22	015488	<b>FITTING, #6 SAE - 1/4" JIC 45° ELBOW</b>		4
23	014686	<b>FITTING, #6 SAE MALE - 1/4" NPT FEMALE</b>		1
24	014685	<b>FITTING, 1/4" NPT X 3/8" HOSE BARB</b>		1
25	P12739	<b>CLAMP, 11/16" HOSE</b>		5
26	P26284	<b>FITTING, 3/8" O-RING - 1/4" JIC</b>		1
27	024198	<b>SWITCH, HYDRAULIC VALVE ELECTRIC</b>		1
28	F05004-13	<b>SCREW, #4-40 X 3/4" SLOTTED</b>		2
29	F05011-21	<b>WASHER, #4 SPLIT LOCK</b>		2
30	F05010-43	<b>NUT, #4-40 HEX</b>		2
31	F05007-7	<b>BOLT, 3/8-16 X 1" HEX HEAD</b>		2
32	F05010-10	<b>NUT, 3/8-16 HEX NYLON LOCK</b>		2
33	015079	<b>SEAL, RUBBER VALVE HANDLE</b>		1
34	015078	<b>PLATE, VALVE HANDLE DECAL</b>		1
35	F05015-7	<b>SCREW, #10-24 X 1/2 SLOTTED HEX SELF-TAPPING</b>		8
36	F05010-14	<b>NUT, #10-24 SELF-LOCKING HEX</b>		2
37	015364	<b>DECAL, 1997 HYDRAULIC CONTROL BOX</b>		1
38	P22683	<b>MANIFOLD, HYDRAULIC CARTRIDGE FILTER</b>		1
39	P20301	Filter, S28 Hydraulic Cartridge		1
40	P12707	<b>FITTING, #6-8 (1/2" NPT) - 3/8" HOSE BARB ELBOW</b>		2
41	P12708	<b>FITTING, #6-6 (3/8" NPT) - 3/8" HOSE BARB ELBOW</b>		2



REF	PART #	DESCRIPTION	COMMENTS	QTY.
42	015490	FITTING, 3/8" NPT MALE - 1/4" NPT FEMALE		1
43	P09142	FITTING, 1/4" NPT - 1/4" JIC ELBOW		1
44	F05005-15	BOLT, 1/4-20 X 1/2" HEX HEAD		2
45	F05011-14	WASHER, 1/4" SPLIT LOCK		2
46	R01892-1	HOSE, 3/8" LOW PRESSURE HYDRAULIC		A/R
47	036315	WIRE ASSEMBLY, 14 GA X 4" #10 & 5/16" RINGS		1
48	036310	CABLE ASSEMBLY, 1 GA X 16" HYDRAULIC PUMP TO SOLENOID		1
49	036312	CABLE ASSEMBLY, 1 GA X 16" HYDRAULIC PUMP GROUND		1
50	036778	PLUG, 1 3/32 NYLON	ECN:38166;	2
	F05011-36	WASHER, 3/8" STAR EXTERNAL		2

### 9.3 Hydraulic Power Supply Strip

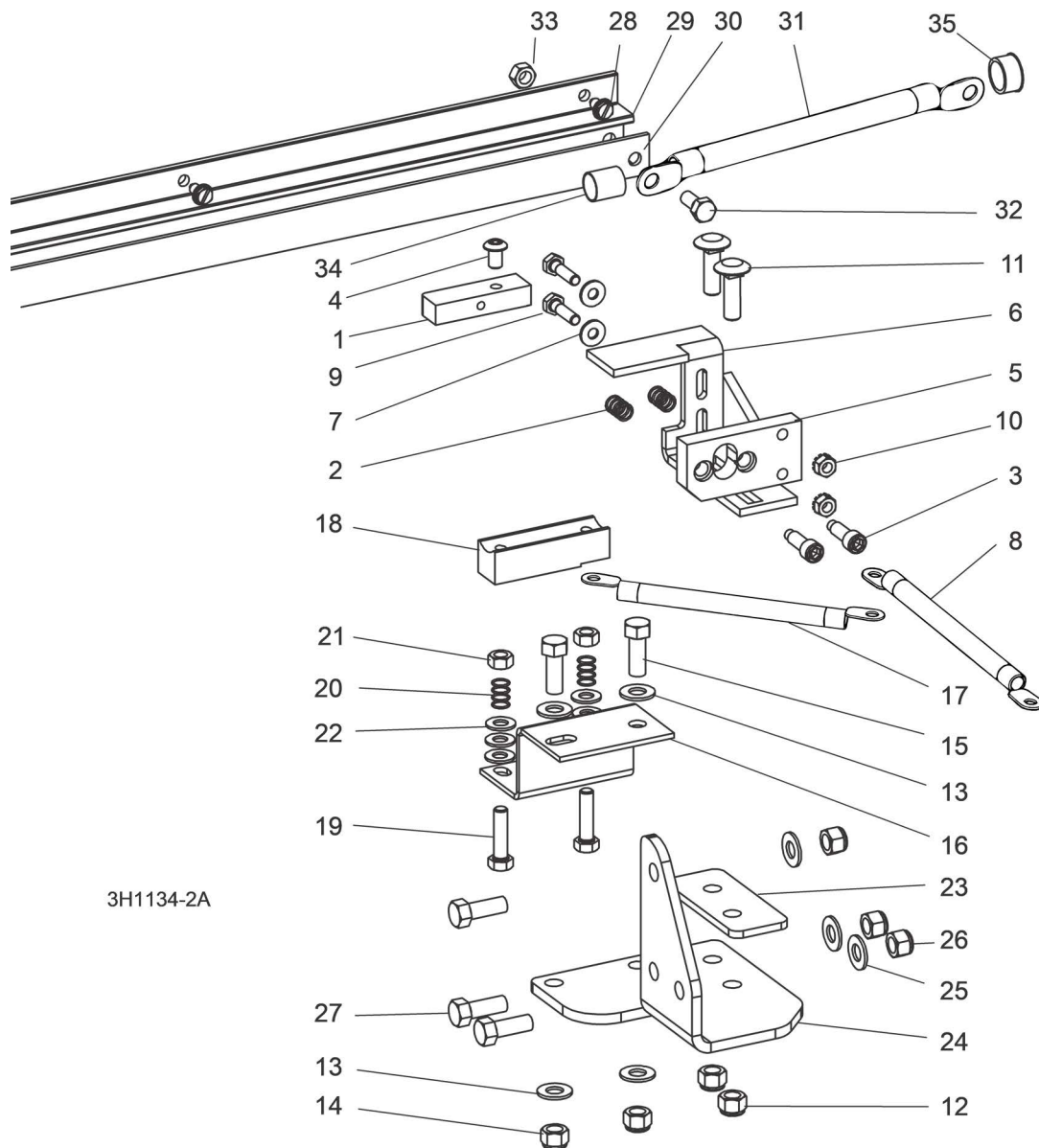

REF	PART #	DESCRIPTION	COMMENTS	QTY.
	010103	<b>CONTACT ASSEMBLY, HYDRAULIC POWER SUPPLY (POSITIVE)</b>		1
	007716	Contact Kit, 97+ Hydraulic Power Supply Positive		1
1	015253	Contact, Hydraulic Power Supply (Positive)	Available in assemblies only.	1
2	P10077	Spring, Positive Contact		2
3	F05006-143	Bolt, 5/16" x 3/4" Shoulder (1/4-20 Thread) Stainless		2
4	F05006-20	Bolt, 5/16-18 x 1/2" Socket Button Head		1
5	S10072	Insulator, Positive Contact		1
6	015324	Bracket, Positive Contact Mounting		1
7	F05011-11	Washer, 1/4" SAE Flat		2

REF	PART #	DESCRIPTION	COMMENTS	QTY.
8	128088	Cable Assy, 1AWG Red x13 (2x5/16 Term)	Cable assemblies replaced R01971 and F05092-16 after 9/17/2019 per ECN 37793.	1
	R01971	Cable, #1 Weld	Available in assemblies only.	1 Ft
	F05092-16	Terminal, 5/16" Ring #2 Gauge		2
9	F05005-38	Bolt, 1/4-20 x 1" Hex Head Grade 2		2
10	F05010-9	Nut, 1/4-20 Hex Self-Locking		2
11	F05007-11	Bolt, 3/8-16 x 1 1/4" Carriage Head		2
12	F05010-10	Nut, 3/8-16 Hex Nylon Lock		2
	065081	<b>CONTACT ASSEMBLY, LT35 HYDRAULIC POWER SUPPLY (GROUND)</b>		1
13	F05011-3	Washer, 3/8" SAE Flat		4
14	F05010-10	Nut, 3/8-16 Hex Nylon Lock		2
15	F05007-7	Bolt, 3/8-16 x 4" Square Head		2
16	016792	Bracket, Ground Contact Mounting		1
17	036306	Cable Assy, 1AWG Blk x26 (2x5/16 Term)	Cable assemblies replaced R01971 and F05092-16 after 9/17/2019 per ECN 37793.	1
	R01971	Cable, #1 Weld	Available in assemblies only.	1 Ft
	F05092-16	Terminal, 5/16" Ring #2 Gauge		1
	007717	Contact Kit, Hydraulic Ground 1997+		1
18	015264	Contact, Hydraulic Power Supply (Ground)	Available in assemblies only.	1
19	F05008-96	Bolt, 5/16-18 x 1 1/2" Hex Head Grade 5		2
20	P10077	Spring, Ground Contact		2
21	F05010-17	Nut, 5/16-18 Hex		2
22	F05011-17	Washer, 5/16" SAE Flat		2
23	025964	<b>PLATE, LT35 POSITIVE CONTACT SPACER</b>		1
24	059636	<b>PLATE, LT35 CONTACT MOUNT</b>		1
25	F05011-3	<b>WASHER, 3/8" SAE FLAT</b>		3
26	F05010-10	<b>NUT, 3/8-16 HEX NYLON LOCK</b>		3
27	F05007-7	<b>BOLT, 3/8-16x1 HHC</b>		3
	A11977	<b>STRIP ASSEMBLY, 6 FT. CONTACT</b>		1
28	F05015-1	Bolt, 1/4-20 x 1/2" Self Tap HH		2
29	P11976	Housing, Contact Strip		1
	A12043-N	Strip, Hydraulic Contact w/Cable		1
30	S10075	Strip, 1/8" x 1" x 69-13/16" Contact	Available in assemblies only.	1
31	052161	Cable Assy, 1AWG Blk x36 (2x5/16 Term)	Cable assemblies replaced R01971 and F05092-16 after 9/17/2019 per ECN 37793.	1
	R01971	Cable, 1AWG SO Welding	Available in assemblies only.	1
	F05092-16	Terminal, 5/16" 1-2Ga Ring NI Loose		2
32	F05006-45	Screw, 5/16-18 x 3/4" Black Nylon HHC		1
33	F05010-86	Nut, 5/16-18 Black Nylon Hex		1
34	R01950-8	Tubing, 5/8" Heat Shrink w/Adhesive ID		1
	A12043-406	Instruction Sheet, Strip Replacement		1
35	P04137	Grommet, 5/8" Wire		1

## 9.4 Hydraulic Log Loader

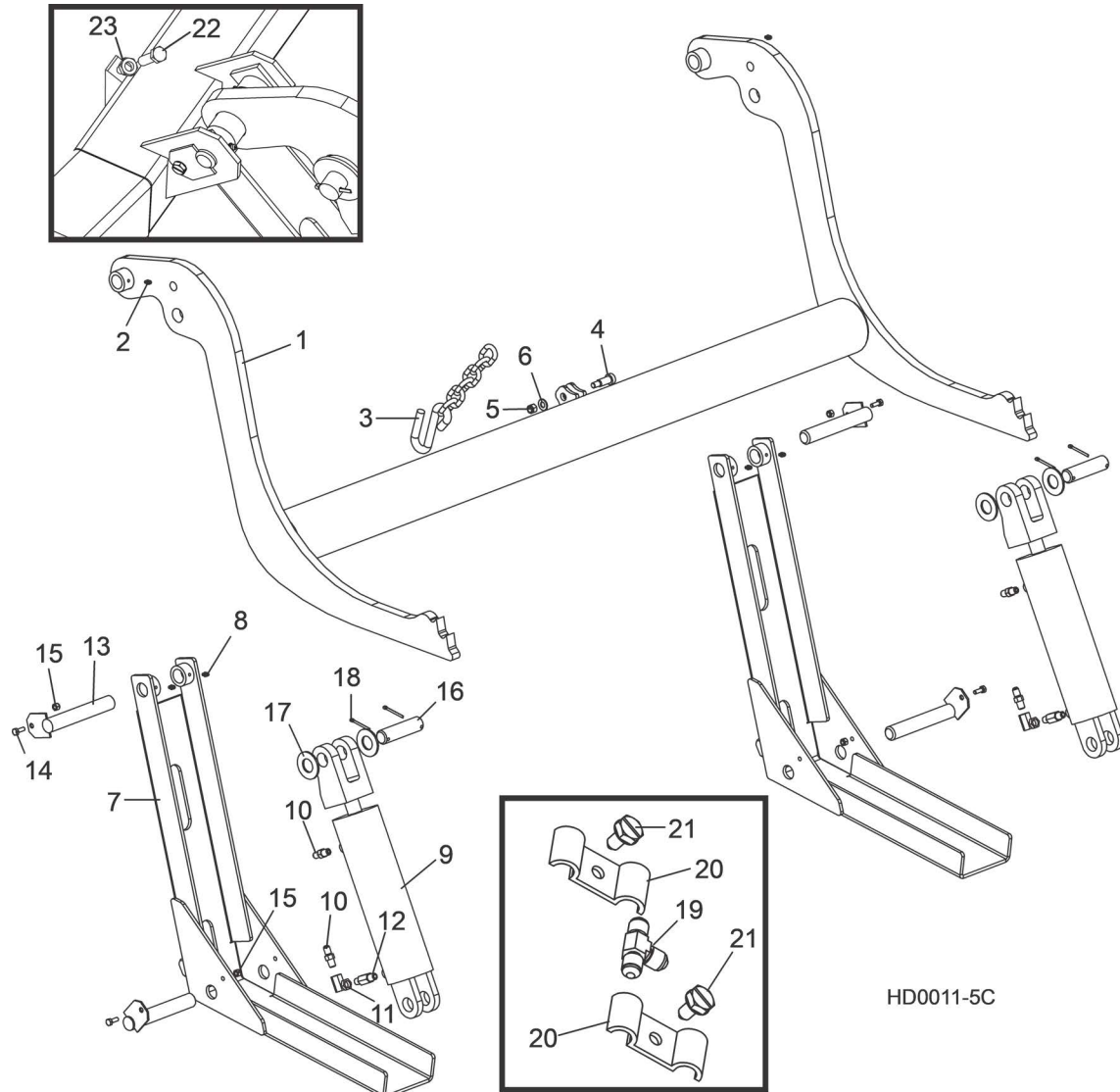

REF	PART #	DESCRIPTION	COMMENTS	QTY.
	LTHDLA-30H	<b>LOADER KIT, HYDRAULIC LOG (LT30HD ONLY)</b>		1
	LTHDLA	<b>LOADER KIT, HYDRAULIC LOG (LT35HD &amp; LT40HD ONLY)</b>		1
	036416	Arm Assembly, Hydraulic Log Loading		1
<b>1</b>	110372	Arm Weldment, Log Loading		1
<b>2</b>	P04107	Fitting, 3/16" Grease		2
<b>3</b>	110472	Chain, 12-1/2 Inch Safety		1
<b>4</b>	F05008-146	Bolt, 1/2 x 1 Shoulder Socket		1
<b>5</b>	F05010-10	Nut, 3/8-16 Hex Nyloc		1
<b>6</b>	F05011-3	Washer, 3/8 Flat SAE		1
<b>7</b>	W09444	Channel, Hydraulic Log Loading Foot		2
<b>8</b>	P04107	Fitting, 3/16" Grease		4
	A09284	Cylinder Assembly, Hydraulic Log Loading Arm	Available in assemblies only.	2
<b>9</b>	P12847	Cylinder, 8" X 3" Hydraulic		1

REF	PART #	DESCRIPTION	COMMENTS	QTY.
	P12956	Seal Kit, 8" x 3" Hydraulic Cylinder		1
10	P09143	Fitting, C5205x4x4 Male Connector		2
11	P12199	Fitting, 0455x4x4 90° Swivel Elbow		1
	015832	Fitting Kit, 1/4NPT 5.0GPM Velocity Fuse		1
12	015750	Fitting, 1/4NPT 5.0GPM Velocity Fuse	Available in assemblies only.	2
	015832-255	Instruction Sheet, Velocity Fuse Replacement		1
13	W09446	Pin, Loading Arm Mount		4
14	F05005-1	Bolt, 1/4-20 x 3/4" Hex Head Full Thread		4
15	F05010-69	Nut, 1/4-20 Hex Lock		4
16	S09251	Pin, Loading Arm Cylinder Mount		2
17	F05011-28	Washer, 1" SAE Flat		4
18	F05012-23	Pin, 3/16" X 1 1/2" Cotter		4
19	P09145	Fitting, C5705x5x4 Union 'T'		2
20	S09245	Clamp, 1/4" Hydraulic Hose		6
21	F05006-102	Bolt, 5/16-18 X 3/4" Hex Head Grade 5		6
22	F05008-116	<b>BOLT, 1/2-13 X 2" HEX HEAD FULL THREAD GRADE 5</b>		2
23	F05010-31	<b>NUT, 1/2-13 JAM</b>		2

## 9.5 Hydraulic Log Turner

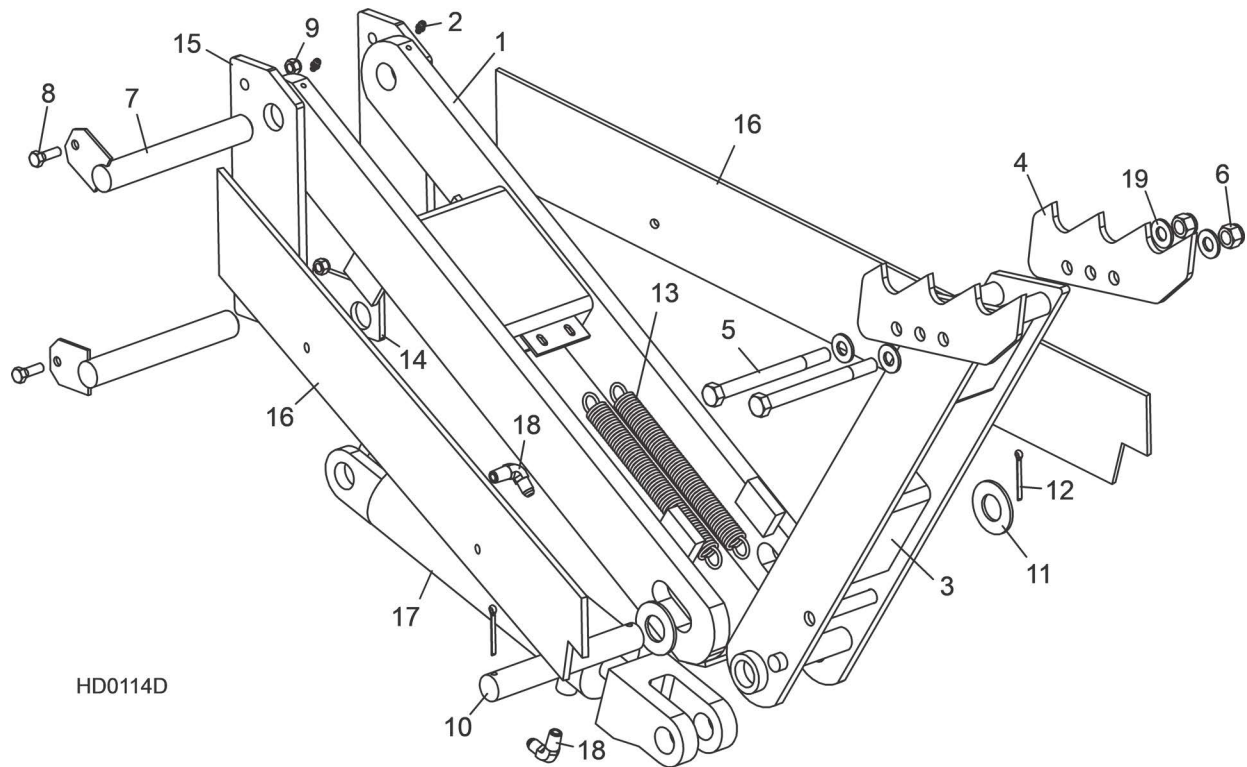

HD0114D

REF	PART #	DESCRIPTION	COMMENTS	QTY.
1	015231	ARM, HYDRAULIC LOG TURNER LINK		1
2	P04107	Fitting, 3/16" Grease		2
3	015233	ARM, HYDRAULIC LOG TURNER PAINTED		1
4	014675	CLAW, HYDRAULIC LOG TURNER		2
5	F05008-28	BOLT, 1/2-13 X 5 1/2" HEX HEAD GRADE 5		2
6	F05010-8	NUT, 1/2-13 NYLON HEX LOCK		2
7	015085	PIN, LOG TURNER MOUNT		2
8	F05006-1	BOLT, 5/16-18 X 1" HEX HEAD GRADE 2		2
9	F05010-6	NUT, 5/16-18 HEX LOCK		2
10	S09246	PIN, LOG TURNER PIVOT		1
11	F05011-28	WASHER, 1" SAE FLAT		2
12	F05012-23	PIN, 3/16" X 1 1/2" COTTER		2
13	015718	SPRING, HYDRAULIC LOG TURNER		2
14	S09155	PLATE, LOG TURNER CYLINDER MOUNT		1
15	S09109	PLATE, LOG TURNER MOUNT		2
16	S09605	PLATE, LOG TURNER BRACE		2
	A09286	CYLINDER ASSEMBLY, HYDRAULIC LOG TURNER		1
17	P12846	Cylinder, 8" X 2 1/2" Hydraulic	Available in assemblies only.	1
	P12955	Seal Kit, 8" x 2 1/2" Hydraulic Cylinder		1
18	P09142	Fitting, 90° Male Elbow		2
19	F05011-2	WASHER, 1/2" SAE FLAT		4

## 9.6 Hydraulic Log Side Supports

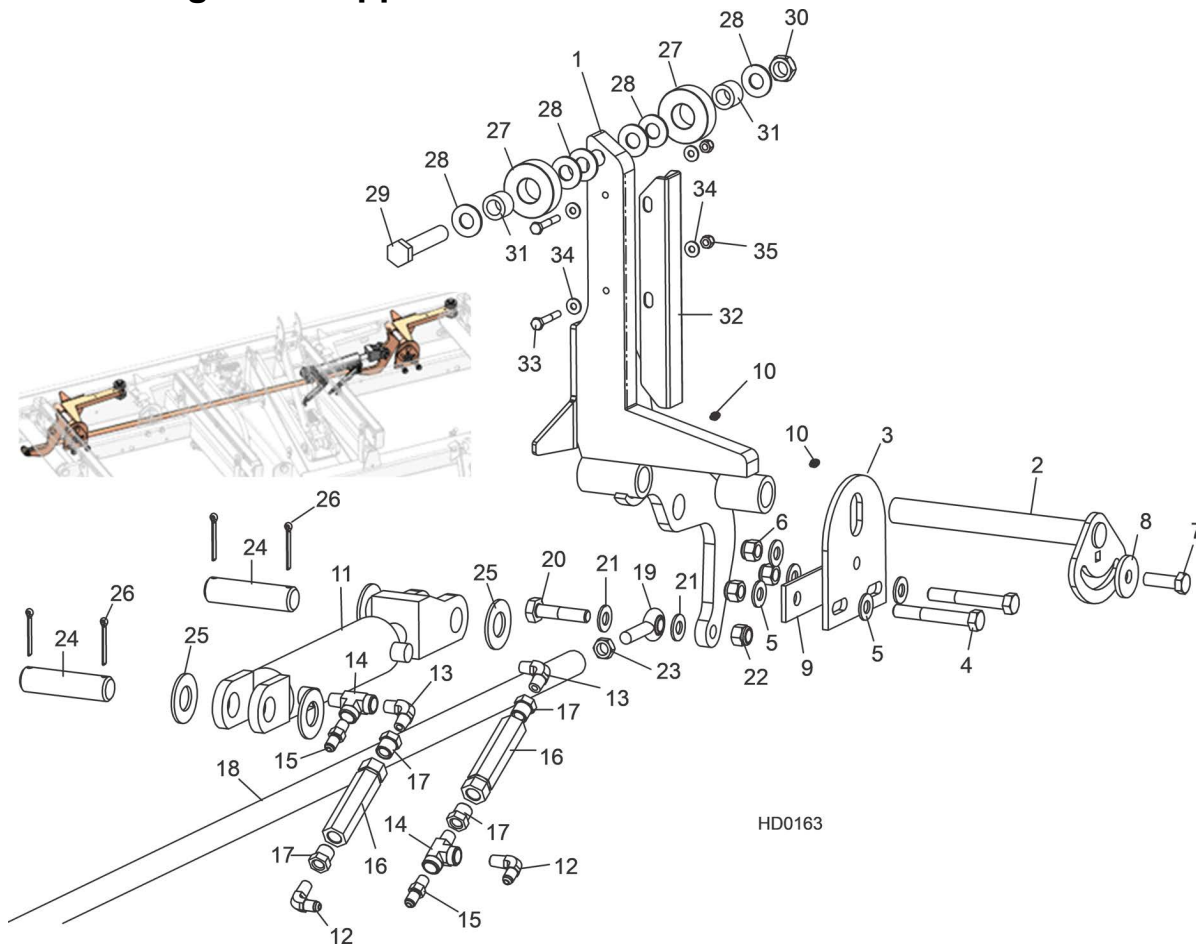

HD0163

REF	PART #	DESCRIPTION	COMMENTS	QTY.
1	015010	Support Weldment, Log Side		2
2	016544	Pin, Log Side Support Pivot		2
3	016555	Plate, Log Side Support End		2
4	F05008-61	Bolt, 1/2-13 X 3 1/2" Hex Head Grade 5		4
5	F05011-2	Washer, 1/2" SAE Flat		10
6	F05010-8	Nut, 1/2-13 Hex Nylon Lock		6
7	F05008-33	Bolt, 1/2-13 X 1 1/2" Hex Head Grade 5		2
8	014632	Washer, .52" x 1.69"		2
9	016558	Plate, Side Support Washer Clamp		2
10	P04107	Fitting, 3/16" Grease		4
	A09283	Cylinder Assembly, Hydraulic Log Side Support		2
11	P12845	Cylinder, 6" X 2" Hydraulic		1
	P12954	Seal Kit, 6" x 2" Hydraulic Cylinder	Service parts	1
12	P09142	Fitting, 90° Male Elbow		2
13	P09140	Fitting, C3529x4 90° Pipe		2
14	P09141	Fitting, C3759x4 Male 'T'		2
15	P09143	Fitting, C5205x4x4 Male Connector		2
16	015484	Valve, Hydraulic Sequence		2
17	015490	Fitting, 3/8" NPT - 1/4" NPT Reducer		4
18	015026	Rod, Hydraulic Side Support Link	(See Section 9.7) if equipped with HSS Option	1
19	P09137	End, 1/2" Rod		2

REF	PART #	DESCRIPTION	COMMENTS	QTY.
20	F05008-10	Bolt, 1/2-13 X 2 1/4" Hex Head Grade 5		2
21	F05011-2	Washer, 1/2" SAE Flat		4
22	F05010-8	Nut, 1/2-13 Hex Nylon Lock		2
23	F05010-16	Nut, 1/2-20 Hex Jam		1
24	S09251	Pin, Cylinder Mount		2
25	F05011-28	Washer, 1" SAE Flat		4
26	F05012-23	Pin, 3/16" X 1 1/2" Cotter		4
	016562	Roller Kit, Side Support	Standard on hydraulic supports only - Optional for manual	2
27	016561	Roller, Side Support		2
28	F05011-5	Washer, 5/8" SAE Flat		6
29	F05009-118	Bolt, 5/8-11 x 3 3/4" Hex Head Grade 5		1
30	F05010-96	Nut, 5/8-11 Hex Nylon Lock Jam		1
31	016560	Bushing, Bronze 5/8" x 1" x 3/4"		2
	016798	Guard Kit, Stainless Steel Side Support	(Optional)	1
32	016722	Guard, Stainless Steel Side Support		4
33	F05005-4	Bolt, 1/4-20 x 1 3/4" Hex Head		8
34	F05011-11	Washer, 1/4" SAE Flat		16
	F05011-5	Washer, 5/8" SAE Flat	For extra spacing on the hydraulic supports	4
35	F05010-69	Nut, 1/4-20 Hex Nylon Lock		8
	016798-1005	Instruction Sheet, Stainless Steel Side Support Guard Retro		1



## 9.7 Hydraulic Log Side Supports (Middle - Optional)

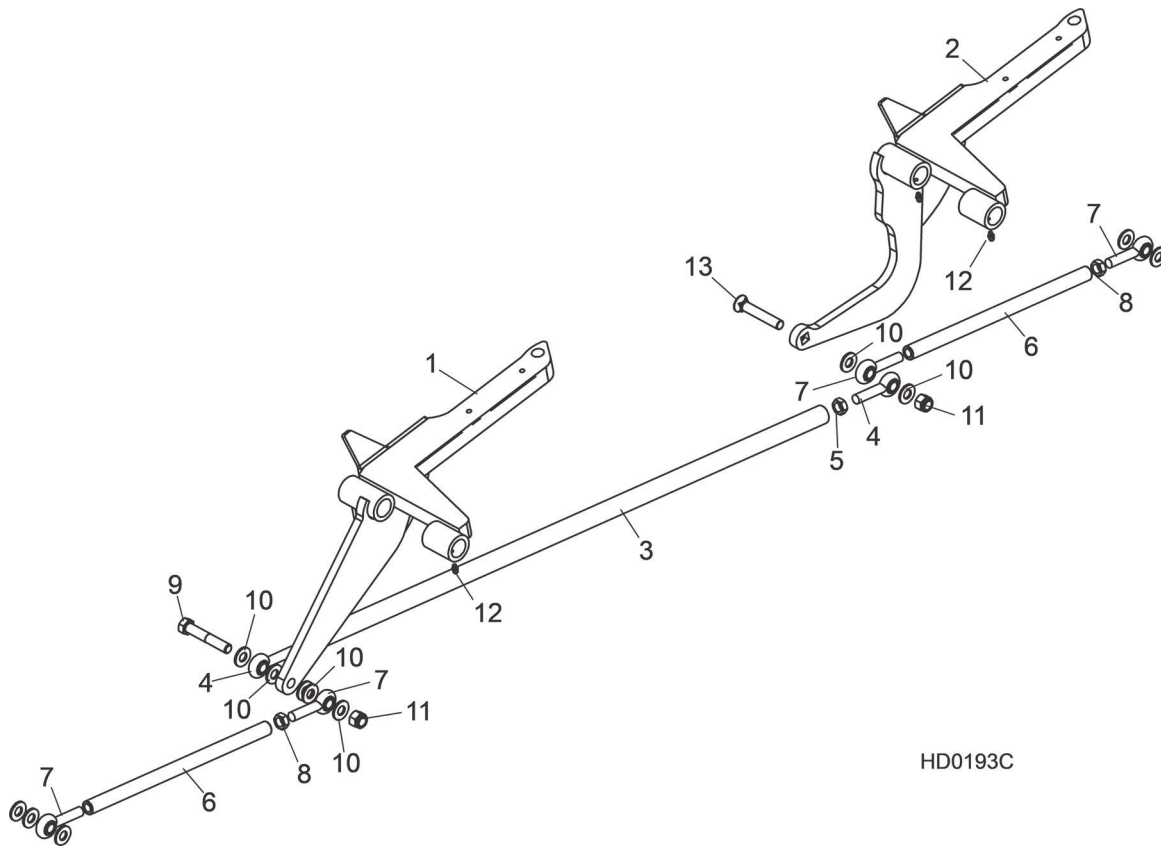

HD0193C

REF	PART #	DESCRIPTION	COMMENTS	QTY.
	HSS-A	Support Assembly, Hydraulic 4-Link Side		1
1	048436	Support Weldment, Front Log Side		1
2	048438	Support Weldment, Rear Log Side		1
3	048537	Rod, 4-Link Side Support		1
4	P09137	Rod End, 1/2 Male		2
5	F05010-16	Nut, 1/2-20 Hex Jam		1
6	048247	Rod Assembly, 4-Link Side Support Short		2
6	048246	Rod, 4-Link Connecting		1
7	P09137	Rod End, 1/2 Male		2
8	F05010-16	Nut, 1/2-20 Hex Jam		1
9	F05008-23	Bolt, 1/2-13 x 3" Hex Head Grade 5		1
10	F05011-2	Washer, 1/2" SAE Flat		12
11	F05010-8	Nut, 1/2-13 Nylon Hex Lock		2
12	P04107	Fitting, 3/16 x 3/16 Straight Grease		4
13	F05008-158	Bolt, 1/2-13 x 3" Flat Head Plow Grade 5		1

## 9.8 Hydraulic Log Clamp

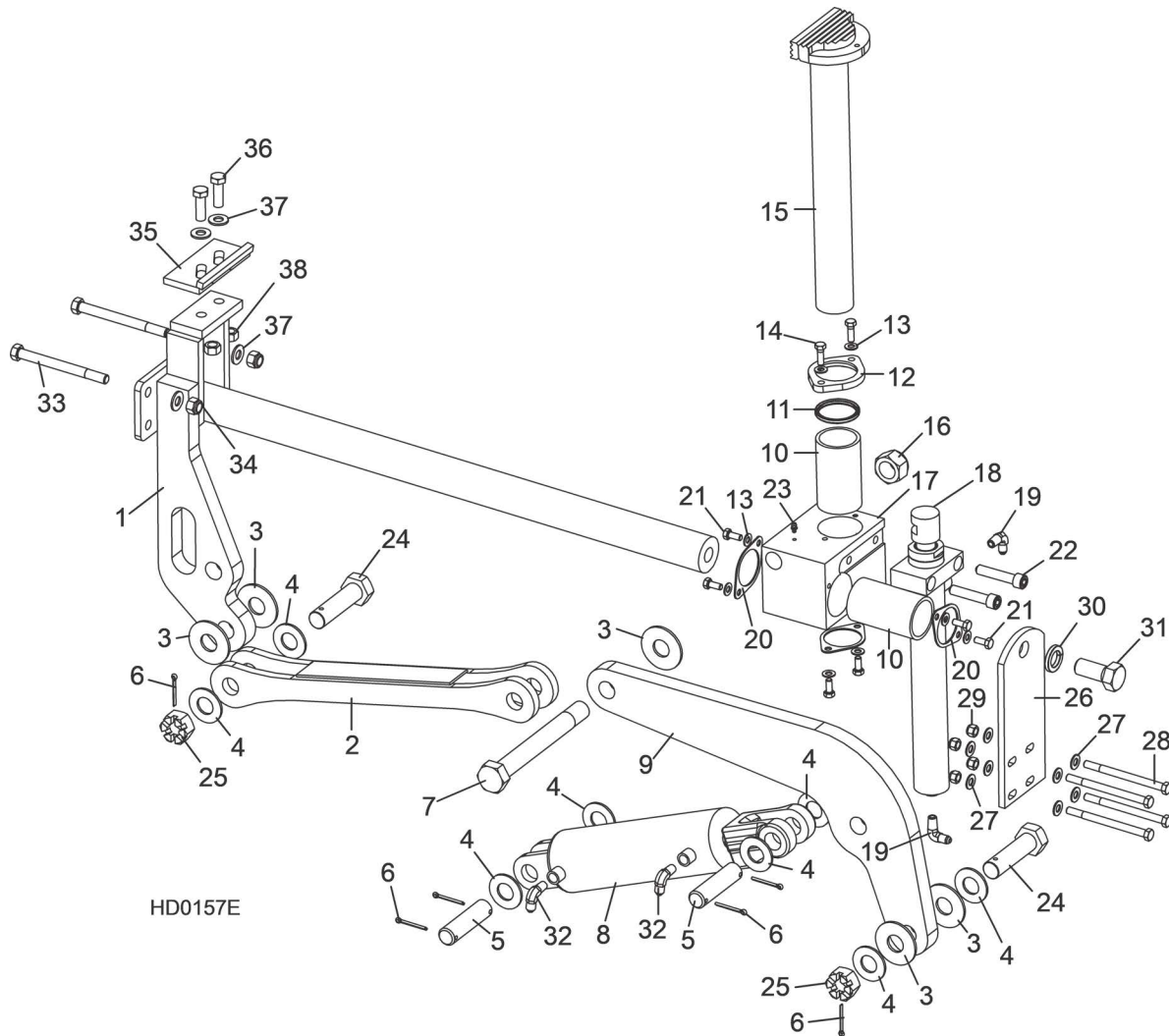

REF	PART #	DESCRIPTION	COMMENTS	QTY.
	017264	<b>CLAMP ASSEMBLY, HYDRAULIC 2-PLANE</b>		1
<b>1</b>	017265	Mount Weldment, Hydraulic Clamp Slide		1
<b>2</b>	017267	Link Weldment, Hydraulic Clamp		1
<b>3</b>	015057	Washer, 1/8" x 2 1/2" Hardened		5
<b>4</b>	F05011-28	Washer, 1" SAE Flat		8
<b>5</b>	S09251	Pin, 1" x 3.88"		2
<b>6</b>	F05012-23	Pin, 3/16" x 1 1/2" Cotter		6
<b>7</b>	015049	Bolt, 1-14 x 8 1/2" Hex Head Grade 8		1
<b>8</b>	017275	Cylinder, 3" x 7" Hydraulic		1
	061365	Seal kit for Bailey Cyl. 017275		
	P12956	Seal Kit, Hydraulic Cylinder	P129956 used for J-D Cyl. (Identify by notched gland retaining nut)	1
<b>9</b>	017274	Arm, Clamp Pivot		1
<b>10</b>	015088	Bushing, Clamp Slide		2
	017271	Wiper Assembly, Vertical Clamp Rod		1
<b>11</b>	017273	Wiper, Vertical Clamp Rod		1
<b>12</b>	017272	Flange, Vertical Clamp Rod Wiper		1

REF	PART #	DESCRIPTION	COMMENTS	QTY.
13	F05011-17	Washer, 5/16" SAE Flat		8
14	F05006-1	Bolt, 5/16-18 x 1" Hex Head		2
15	015043	Clamp Weldment, Vertical		1
16	F05010-141	Nut, 1-14 Nylon Lock		1
17	017270	Block, Hydraulic Clamp Slide		1
18	015050	Cylinder Weldment, Vertical Clamp Hydraulic		1
	061435	Seal kit for 1" Bailey Cyl. 015050	Used on Bailey Cyl. after 8/19	1
	016204	Seal Kit, Hydraulic Cylinder		1
	016204-1009	Instruction Sheet, Vertical Clamp Seal Replacement		1
19	074543	Fitting, 4SAE-4JIC 90° Elbow	Fitting, 1/4" NPT x 1/4" JIC Elbow P09142 was replace with 074543 as of 11/6/2020, per ECN 37711.	2
20	017242	Retainer, Clamp Bushing		3
21	F05006-5	Bolt, 5/16-18 x 3/4" Hex Head		6
22	F05008-39	Bolt, 1/2-13 x 2 1/2" Socket Head		2
23	P04107	Fitting, 3/16" Straight Grease		1
24	015072	Bolt, 1-14 x 3 3/4" Hex Head Grade 8 w/Hole		2
25	F05010-163	Nut, 1-14 Slotted Hex		2
26	015068	Plate, Log Clamp Mount		1
27	F05011-3	Washer, 3/8" SAE Flat		8
28	F05007-5	Bolt, 3/8-16 x 5" Hex Head		4
29	F05010-10	Nut, 3/8-16 Hex Nylon Lock		4
30	F05011-46	Washer, 7/8" Split Lock		1
31	F05014-2	Bolt, 7/8-14 x 2" Hex Head Grade 5		1
32	015491	Fitting, 1/4" NPT - 3/8" JIC Elbow		2
33	F05008-28	Bolt, 1/2-13 x 5 1/2" Hex Head Grade 5		2
34	F05010-8	Nut, 1/2-13 Hex Nylon Lock		2
	K09485	Clamp Stop Kit, Hydraulic Log		1
35	W09404	Plate, Clamp Stop		1
36	F05008-33	Bolt, 1/2-13 X 1 1/2" Hex Head Grade 5		2
37	F05011-2	Washer, 1/2" SAE Flat		2
38	F05010-3	Nut, 1/2-13 Hex Lock		2

## 9.9 Hydraulic Toe Board

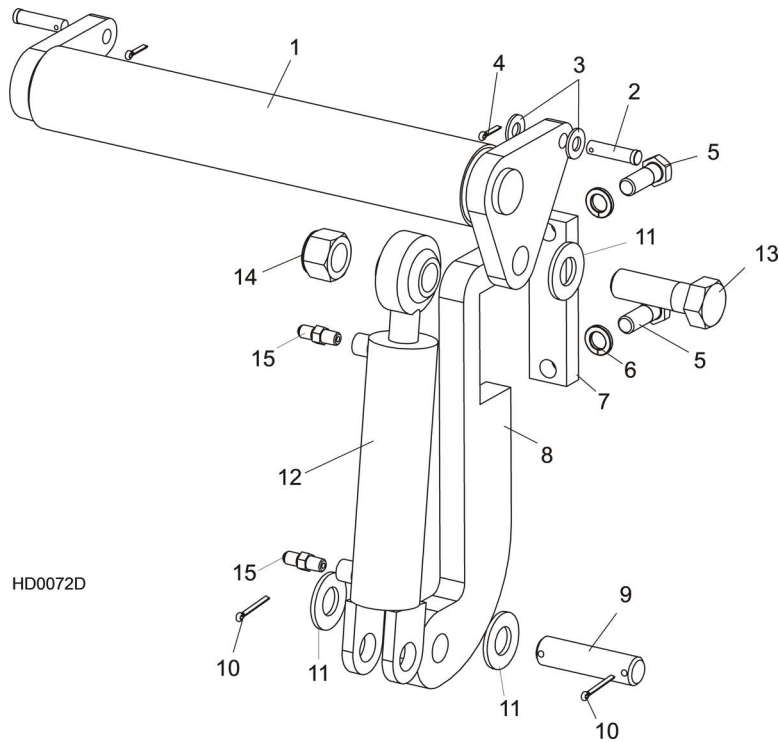

REF	PART #	DESCRIPTION	COMMENTS	QTY.
1	074842	Toe Board Assembly, Hydraulic		2
2	F05012-82	Pin, 1/2-1 3/4 Clevis		4
3	F05011-2	Washer, 1/2" SAE Flat		4
4	F05012-3	Pin, 1/8 x 3/4" Cotter		4
5	F05009-33	Bolt, 5/8-11 x 1 3/4" Hex Head		4
6	F05011-27	Washer, 5/8" Split Lock		4
7	S13023	Plate, Hydraulic ToeBoard Mount		2
8	S13022	Bracket, Hydraulic Toeboard Mount		2
9	S09251	Pin, Cylinder Mount		2
10	F05012-23	Pin, 3/16" x 1 1/2" Cotter		4
11	F05011-28	Washer, 1" SAE Flat		6
12	014482	Cylinder, 1 1/2" x 6" Hydraulic Toe board		2
	014547	Seal Kit, 1 1/2" x 6" Hydraulic Cylinder	Service Kit	1
13	F05009-51	Bolt, 1-8 x 3 1/4" Hex Head Grade 5		2
14	F05010-109	Nut, 1-8 Hex Nylon Lock		2
15	P09143	Fitting, 1/4" NPT x 1/4" JIC Male		4

## SECTION 10 MISCELLANEOUS

### 10.1 Replacement Manuals



REF	DESCRIPTION (◆ Indicates Parts Available In Assemblies Only)	PART #	QTY.
<b>Wood-Mizer Product Information</b>			
1	ALL-PRODUCTS CATALOG	PS750	1
<b>Basic Sawmill Manuals</b>			
2	TRU-SHARP BLADE HANDBOOK	M600	1
3	WOOD-MIZER GENERAL INFORMATION	M601	1
4	LT35HD OPERATOR'S MANUAL	M1773	1
5	LT35HD PARTS MANUAL	M1775	1
<b>Power Option Manuals</b>			
6	D17 ENGINE OPTION MANUAL (LT35)	M1723	1
7	G25 ENGINE OPTION MANUAL (LT35)	M1725	1
<b>Trailer Option Manuals</b>			
8	ELECTRIC BRAKE TRAILER OPTION	M796	1
9	SURGE BRAKE TRAILER OPTION	M794	1
<b>Miscellaneous Option Manuals</b>			
10	SHINGLE/LAPSIDER OPTION MANUAL	M621	1
11	RESAW ATTACHMENT OPTION MANUAL	M263	1
12	BED EXTENSION OPTION MANUAL	M294	1
13	LATHE-MIZER OPTION MANUAL	M1337	1