

Wood-Mizer[®] Sawmill

Parts Manual

LT70HD Wireless rev. B3.02 - B6.08



Safety is our #1 concern! Read and understand all safety information and instructions before operating, setting up or maintaining this machine.

January 2010

Form #1668

Models Affected

LT70HDE30-WRH	Sawmill, LT70HD 30Hp Elec, Wireless, High	B3.02 - B6.08
LT70HDE30W-WRH	Sawmill, LT70HD 30HP, Wide Head, Wireless	B3.02 - B6.08
LT70HDE25-WRH	Sawmill, LT70HD 25Hp Elec, Wireless, High	B3.02 - B6.08
LT70HDE25-WRL	Sawmill, LT70HD 25Hp Elec, Wireless, Low	B3.02 - B6.08
LT70HDD55-WR	Sawmill, LT70HD 55Hp Diesel, Wireless	B3.02-B6.08
LT70HDD55W-WR	Sawmill, LT70HD 55Hp Dsl, Wireless	B3.02-B6.08
LT70HDD55N-WR	Sawmill, LT70HD 55HP Dsl Wireless	B3.02-B6.03
LT70HDE25-WRC	Sawmill, LT70HD25Hp 575V, Wireless	B3.02-B4.04
LT70HDD51-WR	Sawmill, LT70HD51Hp Diesel, Wireless	B3.02-B4.02
LT70HDD62-WR	Sawmill, LT70HD62Hp Diesel, Wireless	B3.02-B4.02

California
Proposition 65 Warning



WARNING: Breathing gas/diesel engine exhaust exposes you to chemicals known to the State of California to cause cancer and birth defects or other reproductive harm.

- Always start and operate the engine in a well-ventilated area.
- If in an enclosed area, vent the exhaust to the outside.
- Do not modify or tamper with the exhaust system.
- Do not idle the engine except as necessary.

For more information go to **www.P65warnings.ca.gov**.



WARNING: Drilling, sawing, sanding or machining wood products can expose you to wood dust, a substance known to the State of California to cause cancer. Avoid inhaling wood dust or use a dust mask or other safeguards for personal protection.

For more information go to **www.P65Warnings.ca.gov/wood**.

©2019

Printed in the United States of America, all rights reserved. No part of this manual may be reproduced in any form by any photographic, electronic, mechanical or other means or used in any information storage and retrieval system without written permission from

Wood-Mizer
8180 West 10th Street
Indianapolis, Indiana 46214

Table of Contents

Section-Page

SECTION 1	GENERAL INFORMATION	1-1
1.1	How To Use The Parts List	1-1
1.2	Sample Assembly	1-1
SECTION 2	BLADE GUIDE ROLLERS & ARM	2-1
2.1	Blade Guide Assembly, Idle Side.....	2-1
	<i>LT60HD/70HD Rev. B4.11+</i>	
2.2	Blade Guide Assembly, Idle Side.....	2-4
	<i>LT60HD/70HD Rev. B3.02 - B4.10</i>	
2.3	Blade Guide Assembly, Drive Side.....	2-7
	<i>LT60HD/70HD Rev. B4.11+</i>	
2.4	Blade Guide Assembly, Drive Side.....	2-10
	<i>LT60HD/70HD Rev. B3.02 - B4.10</i>	
2.5	Blade Guide Arm Drive Assembly.....	2-13
SECTION 3	BLADE WHEELS & TENSIONER	3-1
3.1	Blade Drive Assembly.....	3-1
3.2	Idle Blade Wheel Assembly	3-3
3.3	Hydraulic Blade Tensioner Assembly.....	3-5
	<i>LT70HD Rev. B6.05+</i>	
	<i>LT70HD Rev. A4.01+</i>	
3.4	Hydraulic Blade Tensioner Assembly.....	3-7
	<i>LT70HD Rev. B4.08 - B6.04</i>	
	<i>LT70HD Rev. A1.00 - A4.00</i>	
3.5	Hydraulic Blade Tensioner Assembly.....	3-9
	<i>LT70HD Remote Rev. B4.00 -B4.07</i>	
3.6	Hydraulic Blade Tensioner Assembly.....	3-12
	<i>LT70HD Rev. B3.02</i>	
SECTION 4	SAW HEAD FRAME	4-1
4.1	Middle Throat Screw	4-1
4.2	Belt Tensioner	4-2
4.3	Brake Assembly (DC Only)	4-4
4.4	Autoclutch Assembly (DC Only).....	4-5
	<i>LT70HD Rev. B4.00+</i>	
4.5	Autoclutch Assembly (DC Only).....	4-7
	<i>LT70HD Rev. B3.02</i>	
4.6	Board Return Assembly	4-9
4.7	Water Lube Assembly	4-10
4.8	Saw Head Decals	4-12
4.9	Blade Housing Covers.....	4-13
4.10	Sawdust Chute	4-15
4.11	Debarker Wire Box/Grommet.....	4-16

Table of Contents

Section-Page

SECTION 5	ENGINE OPTIONS	5-1
	<i>LT70HD</i>	
	<i>LT70HD Wireless</i>	
SECTION 6	OPTIONS & ADDITIONAL INCLUDED EQUIPMENT	6-1
	<i>LT70HD/LT70HD Wireless</i>	
SECTION 7	DEBARKER	7-1
7.1	Debarker Assembly (DC Complete)7-1 <i>MKIII LT70 A.00+</i>	
7.2	Debarker Assembly (DC Complete)7-2 <i>MKII LT70 A.00 - B.03</i>	
7.3	Debarker Assembly (AC Complete)7-1 <i>MKIII LT70 A.00+</i>	
7.4	Debarker Assembly (AC Complete)7-2 <i>MKII LT70 A.00 - B.03</i>	
7.5	Frame Assembly7-3 <i>MKIII LT70 A.00+</i>	
7.6	Frame Assembly7-5 <i>MKII LT70 A.00 - B.03</i>	
7.7	In/Out Motor Drive Assembly7-7 <i>MKIII LT70 A.00+</i>	
7.8	In/Out Motor Drive Assembly7-9 <i>MKII LT70 A.00 - B.03</i>	
7.9	Cutter Head Assembly (DC)7-11 <i>MKIII LT70 A.00+</i>	
7.10	Cutter Head Assembly (DC)7-12 <i>MKII LT70 A.00 - B.03</i>	
7.11	Cutter Head Assembly (AC)7-14 <i>MKIII LT70 A.00+</i>	
7.12	Cutter Head Assembly (AC)7-15 <i>MKII LT70 A.00 - B.03</i>	
7.13	Blade Housing Assembly7-17 <i>MKIII LT70 A.00+</i>	
7.14	Blade Housing Assembly7-18 <i>MKII LT70 A.00 - B.03</i>	
7.15	Spring Arm Assembly7-20 <i>MKII LT70 A.00 - B.03</i>	
SECTION 8	CONTROL & BATTERY BOXES	8-1
8.1	Control Assembly (DC)8-1 <i>LT70HD</i> <i>Rev. B4.00+</i>	
8.2	Control Assembly (AC)8-4	
8.3	Control Assembly (DC)8-7 <i>LT70HD</i> <i>Rev. B3.02</i>	

Table of Contents

Section-Page

8.4	Drum Switches	8-10	
8.5	Circuit Breakers.....	8-11	
8.6	Front Panel Assembly & Harnesses	8-12	
	<i>LT70HD</i> <i>Rev. B4.00+</i>		
8.7	Front Panel Assembly & Harnesses	8-14	
	<i>LT70HD</i> <i>Rev. B3.02</i>		
8.8	Battery Box Assembly (DC Only)	8-16	
8.9	Fuse Box Assembly (DC Only).....	8-18	
SECTION 9	UP/DOWN SYSTEM		9-1
9.1	Up/Down Rollers & Covers	9-1	
9.2	Blade Height & Quarter Scales	9-3	
9.3	Up/Down Chain & Sprockets.....	9-4	
9.4	Up/Down Drive Assembly	9-5	
9.5	Up/Down Assist Assembly (DC Only)	9-7	
SECTION 10	FEED SYSTEM & TRACK ROLLERS		10-1
10.1	Upper Track Rollers And Wipers.....	10-1	
10.2	Power Feed Assembly	10-3	
10.3	Feed Chain/Stop	10-5	
10.4	Lower Track Rollers.....	10-6	
SECTION 11	BED FRAME ASSEMBLY		11-1
11.1	Bed Rail Assembly, Front And Rear.....	11-1	
11.2	Bed Rail Assembly, Middle Front.....	11-3	
11.3	Bed Rail Assembly, Middle Rear.....	11-4	
11.4	Leg Assembly (Stationary).....	11-5	
11.5	Board Return Table Assembly	11-7	
11.6	Pivot Bed Rail Assembly.....	11-8	
11.7	Taper Roller Pivot Assembly	11-10	
11.8	Log Side Support Assembly (Manual).....	11-11	
11.9	Safety Chain Assembly	11-13	
11.10	Saw Head Rest Pin Assembly	11-14	
11.11	Bed Frame Decals.....	11-15	
	<i>After 11/15/10</i>		
11.12	Bed Frame Decals.....	11-16	
	<i>Prior to 11/15/10</i>		
11.13	Board Outfeed Table (Optional).....	11-17	
SECTION 12	BED HYDRAULIC SYSTEM		12-1
12.1	Hydraulic Hoses	12-1	
12.2	Hydraulic Pump Box (DC).....	12-3	
12.3	Hydraulic Pump Box (230/460V AC).....	12-6	
12.4	Hydraulic Pump Box (575V AC).....	12-9	
	<i>LT60/70</i> <i>Rev. B3.02 - B4.04</i>		
12.5	Hydraulic Control Box (230/460V AC).....	12-11	

Table of Contents

Section-Page

12.6	Hydraulic Control Box (575V AC).....	12-13
	<i>LT60/70</i> <i>Rev. B3.02 - B4.04</i>	
12.7	Hydraulic Power Supply Strip (DC Only).....	12-15
12.8	Hydraulic Power Supply Strip (575V AC Only).....	12-17
	<i>LT60HD/70HD</i> <i>Rev. B3.02 - B4.04</i>	
12.9	Hydraulic Log Loader	12-19
12.10	Hydraulic Log Turner.....	12-21
12.11	Hydraulic Log Side Supports (Front).....	12-23
12.12	Hydraulic Log Side Supports (Rear).....	12-25
12.13	Hydraulic Log Side Supports (Link).....	12-27
12.14	Hydraulic Log Clamp.....	12-28
12.15	Hydraulic Toe Board.....	12-30
SECTION 13	ACCESSORIES	13-31
	<i>LT70HD/LT70HD Wireless</i>	
SECTION 14	TRAILERS	14-1
	<i>LT70HD/LT70HD Wireless</i>	
SECTION 15	MISCELLANEOUS	15-1
15.1	Replacement Manuals	15-1
15.2	Tools.....	15-3
	INDEX	I

SECTION 1 GENERAL INFORMATION

1.1 How To Use The Parts List

- Use the table of contents or index to locate the assembly that contains the part you need.
- Go to the appropriate section and locate the part in the illustration.
- Use the number pointing to the part to locate the correct part number and description in the table.
- Parts shown indented under another part are included with that part.
- Parts marked with a diamond (◆) are only available in the assembly listed above the part.

See the sample table below. Sample Part #A01111 includes part F02222-2 and subassembly A03333. Subassembly A03333 includes part S04444-4 and subassembly K05555. The diamond (◆) indicates that S04444-4 is not available except in subassembly A03333. Subassembly K05555 includes parts M06666 and F07777-77. The diamond (◆) indicates M06666 is not available except in subassembly K05555.

1.2 Sample Assembly				
REF	DESCRIPTION (◆ Indicates Parts Available In Assemblies Only)	PART #	QTY.	
	SAMPLE ASSEMBLY, COMPLETE (INCLUDES ALL INDENTED PARTS BELOW)	A01111	1	
1	Sample Part	F02222-22	1	
	Sample Subassembly (Includes All Indented Parts Below)	A03333	1	
2	Sample Part (◆ Indicates Part Is Only Available With A03333)	S04444-4	1	◆
	Sample Subassembly (Includes All Indented Parts Below)	K05555	1	
3	Sample Part (◆ Indicates Part Is Only Available With K05555)	M06666	2	◆
4	Sample Part	F07777-77	1	

To Order Parts:

- From the continental U.S., call **1-800-525-8100** to order parts. Have your customer number, vehicle identification number, and part numbers ready when you call.
- From other international locations, contact the Wood-Mizer distributor in your area for parts.

2 Blade Guide Rollers & Arm

Blade Guide Assembly, Idle Side

SECTION 2 BLADE GUIDE ROLLERS & ARM

2.1 Blade Guide Assembly, Idle Side

LT60HD/70HD

Rev. B4.11+

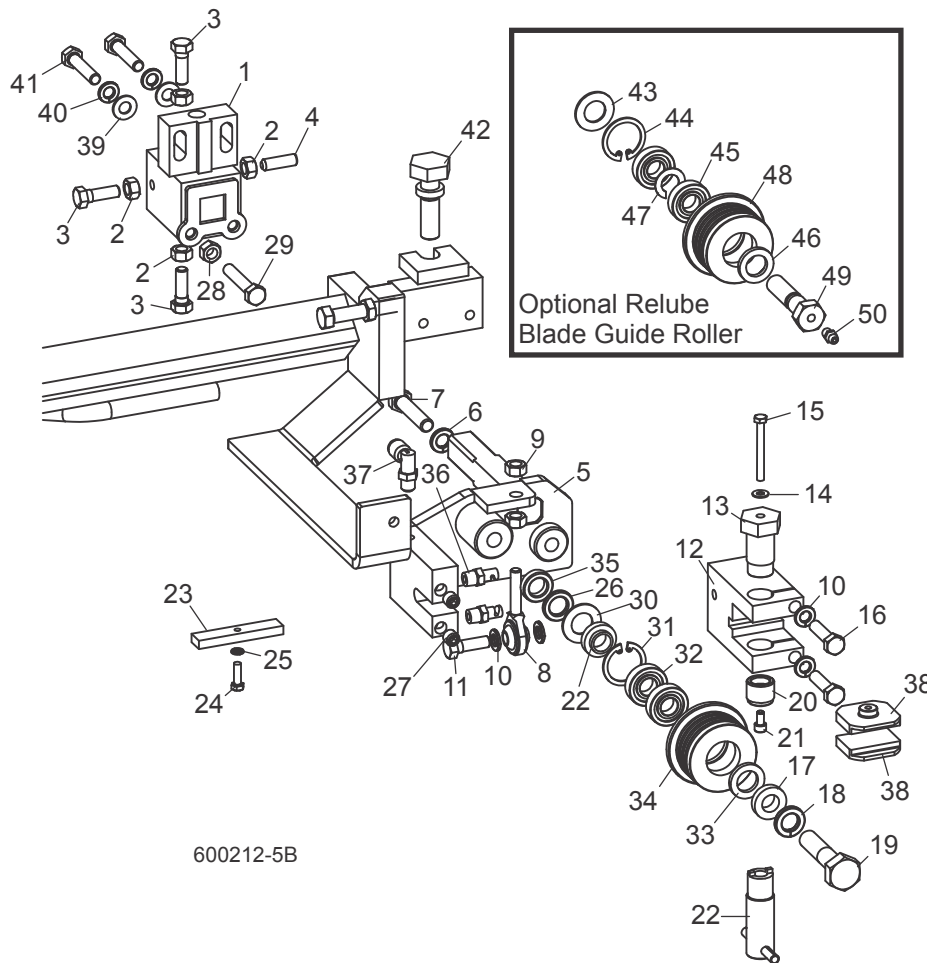

600212-5B

REF	DESCRIPTION (◆ Indicates Parts Available In Assemblies Only)	PART #	QTY.	
	ROLLER/BLOCK ASSEMBLY, IDLE SIDE (OUTER)	036818	1	
	Block Assembly, Blade Guide Mount	036872	1	
1	Block Weldment, Blade Guide Mount	036868	1	◆
2	Nut, 5/16-18 Hex	F05010-17	4	
3	Bolt, 5/16-18 x 1" Hex Head Stainless Steel	F05006-88	3	
4	Screw, 5/16-18 x 1" Socket Head Flat Point Stainless Steel Set	F05006-122	1	
5	Shaft Weldment, Idle Side Guide	036866	1	
6	Washer, 3/8" Split Lock	F05011-4	1	
7	Bolt, 3/8-16 x 1 3/4" Hex Head Grade 5	F05007-119	1	

8	Rod End, 5/16-24 Male	P09814	1	
9	Nut, 5/16-24 Hex Jam	F05010-28	2	
10	Washer, 5/16" Split Lock	F05011-13	4	
11	Bolt, 5/16-18 x 1" Hex Head Stainless Steel	F05006-88	1	
12	Block, Guide Block Mount	036814	1	
13	Bolt, Blade Guide Block Mount	035216	1	
14	Washer, #10 Brass	042867	1	
15	Bolt, #10-32 x 1 3/4" Hex Head Stainless Steel	F05004-178	1	
16	Bolt, 5/16-18 x 1 1/4" Hex Head Stainless Steel	F05006-118	2	
17	Spacer, Blade Guide	S04253	2	
18	Washer, 1/2" Split Lock	F05011-9 ¹	1	
19	Bolt, 1/2-13 x 2 1/4" Hex Head Grade 5	F05008-10	1	
20	Screw, Lower Block Adjustment	044057	1	
21	Screw, #10-32 x 3/8" Socket Head Stainless Steel	F05004-200	1	
22	Tool, Lower Block Adjustment	044064	1	
23	Block, Blade Guide Alignment	035799	1	
24	Screw, #10-32 x 5/8" Hex Head	F05004-152	1	
25	Washer, #10 Split Lock	F05011-20	1	
26	Spacer, 1/2" ID x 7/8" OD x 1/8" Thick	052364 ³	1	
27	Fitting, 1/8" NPT Socket Pipe Plug	P30127	2	
28	Nut, 5/16-18 Hex	F05010-17	1	
29	Bolt, 5/16-18 x 1 3/4" Hex Head Full Thread Grade 5	F05006-81	1	
	ROLLER ASSEMBLY, BLADE GUIDE (STANDARD FOR USE WITH 1 1/4" & 1 1/2" BLADES)	A04925 ²	1	
	ROLLER ASSEMBLY, EXTENDED BLADE GUIDE (OPTIONAL FOR USE WITH 1 1/2" BLADES)	014299 ²	1	
	Bearing Kit, Blade Guide Rebuild	K07079	1	
30	Washer, 5/8" White Felt	P04252	1	
31	Ring, 1 1/8" Interior Retaining	F04254-1	1	
32	Bearing, R8-2RS Blade Guide	015975	2	◆
33	Washer, 5/8" Gray Felt	P06455	1	
	Screw, 1/4-28 x 1/4" Socket Head Cup Point Set Black Oxide	F05005-105	1	
	Instruction Sheet, Blade Guide Rebuild	057407-1507	1	
34	Roller, Flanged Blade Guide (1 1/4" & 1 1/2" blade)	S04250	1	◆
	Roller, Flanged Blade Guide (1 1/2" blade)	014243	1	◆
	Instruction Sheet, Blade Guide Roller Replacement	A04925-364	1	
35	SPACER, 1/2" ID X 7/8" OD X 1/4" (FOR USE WITH 1 1/4" BLADES ONLY)	041626 ³	1	
36	FITTING, BLADE LUBE SPRAY NOZZLE	033479 ⁴	2	
37	FITTING, 1/8" MPT X 1/4" TUBE SWIVEL ELBOW	P09736 ⁴	1	
38	BLOCK, BLADE GUIDE WEAR (STANDARD FOR 1 1/2" BLADES)	052309 ⁵	2	
	BLOCK, BLADE GUIDE WEAR (OPTIONAL FOR 1 1/4" BLADES)	052355	2	
	BLOCK ASSEMBLY, 1" SQ. EZ-GLIDE WEAR	036347	2	
	SHIM, .008" BLADE GUIDE BLOCK SPACER	035248	1	

2

Blade Guide Rollers & Arm

Blade Guide Assembly, Idle Side

39	WASHER, 5/16" SAE FLAT	F05011-17	2	
40	WASHER, 5/16" SPLIT LOCK	F05011-13	2	
41	BOLT, 5/16-18 X 1 1/2" HEX HEAD GRADE 5 FULL THREAD	F05006-76	2	
42	BOLT, BLADE GUIDE VERTICAL ADJUSTMENT	035656	1	
	ROLLER ASSEMBLY, BLADE GUIDE RELUBE (OPTIONAL FOR USE WITH 1 1/4" & 1 1/2" BLADES)	016568 ²	1	
	ROLLER ASSEMBLY, EXTENDED BLADE GUIDE RELUBE (OPTIONAL FOR USE WITH 1 1/2" BLADES)	057405 ²	1	
	Bearing Kit, Relube Blade Guide Rebuild	057407	1	
43	Washer, 5/8" White Felt	P04252	1	
44	Ring, 1 1/8" Interior Retaining	F04254-1	1	
45	Bearing, R8-2RS Blade Guide (modified)	015975 ⁶	2	◆
46	Washer, 5/8" Gray Felt	P06455	1	
47	Spacer, Blade Guide Bearing	035411	1	
	Instruction Sheet, Blade Guide Rebuild	057407-1507	1	
48	Roller, Flanged Blade Guide (Relube 1 1/4" & 1 1/2" blade)	035426	1	◆
	Roller, Flanged Blade Guide (Relube 1 1/2" blade)	057402	1	◆
	Instruction Sheet, Blade Guide Roller Replacement	A04925-364	1	
49	BOLT, BLADE GUIDE ROLLER (RELUBE ONLY)	036161	1	
50	FITTING, 1/4-28 GREASE (RELUBE ONLY)	P05060	1	

¹ Nord-Lock Washer F05011-125 available to replace Split Lock Washer F05011-9 to prevent loosening due to vibration (12/09).

² The sawmill is equipped standard with non-greasable blade guide rollers that can be used with the standard 1 1/2" blade. The roller can also be used with 1 1/4" blades (requires spacer 041626 & wear blocks 052355). Optional extended blade guide rollers are available for use with 1 1/2" blades. The extended rollers may provide more stability during difficult sawing, but will reduce the total amount of times the blade can be reused after sharpening. Optional relube versions of each roller configuration are also available.

³ Use 1/8" spacer 052364 with 1 1/2" blade provided as standard equipment. Use 1/4" spacer 041626 for optional 1 1/4" blades.

⁴ Fittings removed from blade guide assembly BOM to allow structuring of blade guide assembly in various equipment (11/05).

⁵ 052309 blocks for use with 1 1/2" blade provided as standard equipment. 052355 blocks available for optional use with 1 1/4" blades. EZ-Glide blocks 036347 are available for customers who prefer this block.

⁶ Bearing must be modified for use with relube roller assemblies. Remove one seal from each bearing, place open sides facing each other and place spacer 035411 between bearings.

2.2 Blade Guide Assembly, Idle Side

LT60HD/70HD

Rev. B3.02 - B4.10

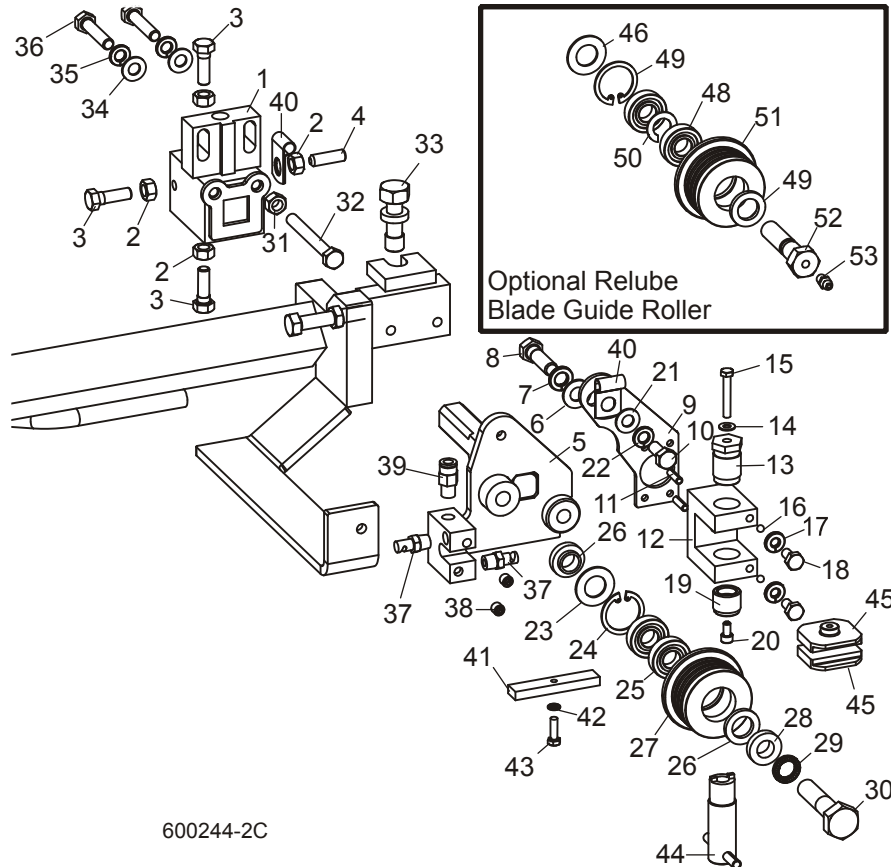

600244-2C

REF	DESCRIPTION (◆ Indicates Parts Available In Assemblies Only)	PART #	QTY.	
	ROLLER/BLOCK ASSEMBLY, IDLE SIDE (OUTER)	003926 ¹	1	
	Block Assembly, Blade Guide Mount	065677	1	
1	Block Weldment, Blade Guide Mount	003911	1	◆
2	Nut, 5/16-18 Hex	F05010-17	4	
3	Bolt, 5/16-18 x 1" Hex Head Stainless Steel	F05006-88	3	
4	Screw, 5/16-18 x 1" Socket Head Flat Point Stainless Steel Set	F05006-122	1	
5	Shaft Weldment, Idle Side Guide	003924	1	
	Mount Assembly, Blade Guide Block Idle	003928	1	
6	Washer, 3/8" SAE Flat	F05011-3	1	
7	Washer, 3/8" Split Lock	F05011-4	1	
8	Bolt, 3/8-16 x 1 1/4" Hex Head Grade 5	F05007-123	1	
9	Plate, Block Tilt Adjustment	003915	1	
10	Bolt, 5/16-18 x 3/4" Hex Head	F05006-102	1	
11	Pin, 3/16" x 5/8" Roll	F05012-22	2	

2

Blade Guide Rollers & Arm

Blade Guide Assembly, Idle Side

12	Block, Guide Block Mount	003909	1	
13	Bolt, Blade Guide Block Mount	003994	1	
14	Washer, #10 Brass	042867	1	
15	Bolt, #10-32 x 1 1/4" Hex Head Stainless Steel	F05004-240	1	
16	Ball, 3/16" Dia. Nylon	003914	2	
17	Washer, 1/4" Split Lock	F05011-14	2	
18	Bolt, 1/4-20 x 1/2" Hex Head	F05005-15	2	
19	Screw, Lower Block Adjustment	044057	1	
20	Screw, #10-32 x 3/8" Socket Head Stainless Steel	F05004-200	1	
21	Washer, 5/16" SAE Flat	F05011-17	1	
22	Washer, 5/16" Split Lock	F05011-13	1	
	Roller Assembly, Blade Guide (standard for use with 1 1/4" & 1 1/2" blades)	A04925 ²	1	
	Roller Assembly, Extended Blade Guide (optional for use with 1 1/2" blades)	014299 ²	1	
	Bearing Kit, Blade Guide Rebuild	K07079	1	
23	Washer, 5/8" White Felt	P04252	1	
24	Ring, 1 1/8" Interior Retaining	F04254-1	1	
25	Bearing, R8-2RS Blade Guide	015975	2	◆
26	Washer, 5/8" Gray Felt	P06455	1	
	Screw, 1/4-28 x 1/4" Socket Head Cup Point Set Black Oxide	F05005-105	1	
	Instruction Sheet, Blade Guide Rebuild	057407-1507	1	
27	Roller, Flanged Blade Guide (1 1/4" & 1 1/2" blade)	S04250	1	◆
	Roller, Flanged Blade Guide (1 1/2" blade)	014243	1	◆
	Instruction Sheet, Blade Guide Roller Replacement	A04925-364	1	
28	Spacer, Blade Guide	S04253	2	
29	Washer, 1/2" Nord-Lock	F05011-125	1	
30	Bolt, 1/2-13 x 2 1/4" Hex Head Grade 5	F05008-10	1	
31	Nut, 5/16-18 Hex	F05010-17	1	
32	Bolt, 5/16-18 x 2 3/4" Hex Head Full Thread	F05006-136	1	
33	Bolt, Blade Guide Vertical Adjustment	035656	1	
34	Washer, 5/16" SAE Flat	F05011-17	2	
35	Washer, 5/16" Split Lock	F05011-13	2	
36	Bolt, 5/16-18 x 1 1/2" Hex Head Grade 5 Full Thread	F05006-76	2	
37	Fitting, Blade Lube Spray Nozzle	033479	2	
38	Fitting, 1/16" NPT Socket Pipe Plug	007734	2	
39	Fitting, 1/8" NPT x 1/4" Tube	P03078	1	
40	Clamp, 1/4" Wire 13/32" Mounting Hole	024155	2	
41	BLOCK, BLADE GUIDE ALIGNMENT	035799	1	
42	SCREW, #10-32 X 5/8" HEX HEAD	F05004-152	1	
43	WASHER, #10 SPLIT LOCK	F05011-20	1	
44	TOOL, LOWER BLOCK ADJUSTMENT	044064	1	
45	BLOCK, BLADE GUIDE WEAR (STANDARD FOR 1 1/2" BLADES)	052309 ³	2	
	BLOCK, BLADE GUIDE WEAR (OPTIONAL FOR 1 1/4" BLADES)	052355	2	
	BLOCK ASSEMBLY, 1" SQ. EZ-GLIDE WEAR	036347	2	

	SHIM, .008" BLADE GUIDE BLOCK SPACER	035248	1	
	ROLLER ASSEMBLY, BLADE GUIDE RELUBE (OPTIONAL FOR USE WITH 1 1/4" & 1 1/2" BLADES)	016568 ²	1	
	ROLLER ASSEMBLY, EXTENDED BLADE GUIDE RELUBE (OPTIONAL FOR USE WITH 1 1/2" BLADES)	057405 ²	1	
	Bearing Kit, Relube Blade Guide Rebuild	057407	1	
46	Washer, 5/8" White Felt	P04252	1	
47	Ring, 1 1/8" Interior Retaining	F04254-1	1	
48	Bearing, R8-2RS Blade Guide (modified)	015975 ⁴	2	◆
49	Washer, 5/8" Gray Felt	P06455	1	
50	Spacer, Blade Guide Bearing	035411	1	
	Instruction Sheet, Blade Guide Rebuild	057407-1507	1	
51	Roller, Flanged Blade Guide (Relube 1 1/4" & 1 1/2" blade)	035426	1	◆
	Roller, Flanged Blade Guide (Relube 1 1/2" blade)	057402	1	◆
	Instruction Sheet, Blade Guide Roller Replacement	A04925-364	1	
52	BOLT, BLADE GUIDE ROLLER (RELUBE ONLY)	036161	1	
53	FITTING, 1/4-28 GREASE (RELUBE ONLY)	P05060	1	

¹ 003926 Blade Guide Assembly replaced with 036818 Rev. B4.11. New assembly provides easier adjustment ([See Section 2.1](#))

² The sawmill is equipped standard with non-greasable blade guide rollers that can be used with the standard 1 1/2" blade. The roller can also be used with 1 1/4" blades. Optional extended blade guide rollers are available for use with 1 1/2" blades. The extended rollers may provide more stability during difficult sawing, but will reduce the total amount of times the blade can be reused after sharpening. Optional relube versions of each roller configuration are also available.

³ 052309 blocks for use with 1 1/2" blade provided as standard equipment. 052355 blocks available for optional use with 1 1/4" blades. EZ-Glide blocks 036347 are available for customers who prefer this block.

⁴ Bearing must be modified for use with relube roller assemblies. Remove one seal from each bearing, place open sides facing each other and place spacer 035411 between bearings.

2 Blade Guide Rollers & Arm

Blade Guide Assembly, Drive Side

2.3 Blade Guide Assembly, Drive Side

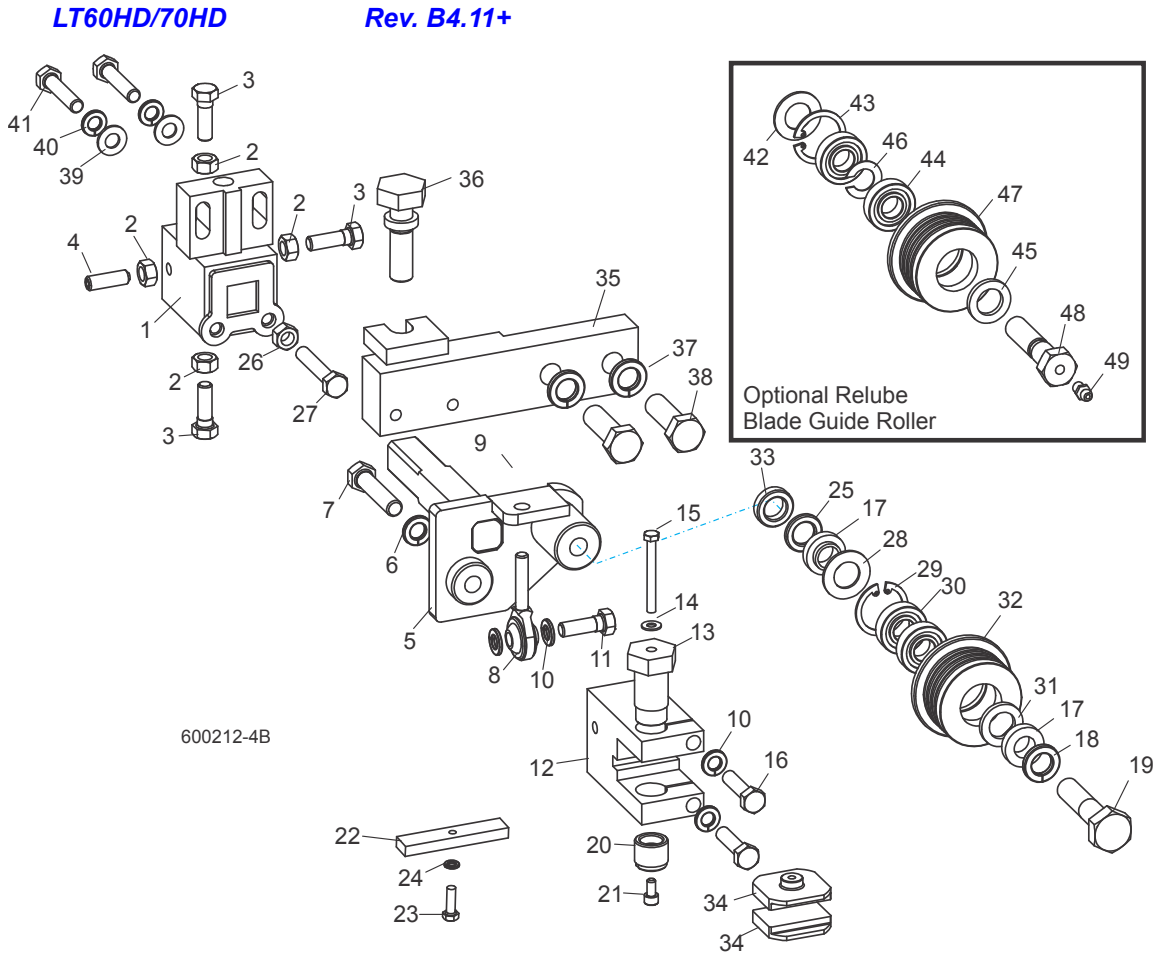

REF	DESCRIPTION (◆ Indicates Parts Available In Assemblies Only)	PART #	QTY.	
	ROLLER/BLOCK ASSEMBLY, DRIVE SIDE (INNER)	036812	1	
	Block Assembly, Blade Guide Mount	036867	1	
1	Block Weldment, Blade Guide Mount	036868	1	◆
2	Nut, 5/16-18 Hex	F05010-17	4	
3	Bolt, 5/16-18 x 1" Hex Head Stainless Steel	F05006-88	3	
4	Screw, 5/16-18 x 1" Socket Head Flat Point Stainless Steel Set	F05006-122	1	
5	Shaft Weldment, Drive Side Guide	036865	1	
6	Washer, 3/8" Split Lock	F05011-4	1	
7	Bolt, 3/8-16 x 1 3/4" Hex Head Grade 5	F05007-119	1	
8	Rod End, 5/16-24 Male	P09814	1	
9	Nut, 5/16-24 Hex Jam	F05010-28	2	
10	Washer, 5/16" Split Lock	F05011-13	4	
11	Bolt, 5/16-18 x 1" Hex Head Stainless Steel	F05006-88	1	
12	Block, Guide Block Mount	036814	1	

Blade Guide Rollers & Arm

Blade Guide Assembly, Drive Side

2

13	Bolt, Blade Guide Block Mount	035216	1	
14	Washer, #10 Brass	042867	1	
15	Bolt, #10-32 x 1 3/4" Hex Head Stainless Steel	F05004-178	1	
16	Bolt, 5/16-18 x 1 1/4" Hex Head Stainless Steel	F05006-118	2	
17	Spacer, Blade Guide	S04253	2	
18	Washer, 1/2" Split Lock	F05011-9 ¹	1	
19	Bolt, 1/2-13 x 2 1/4" Hex Head Grade 5	F05008-10	1	
20	Screw, Lower Block Adjustment	044057	1	
21	Screw, #10-32 x 3/8" Socket Head Stainless Steel	F05004-200	1	
22	Block, Blade Guide Alignment	035799	1	
23	Screw, #10-32 x 5/8" Hex Head	F05004-152	1	
24	Washer, #10 Split Lock	F05011-20	1	
25	Spacer, 1/2" ID x 7/8" OD x 1/8" Thick	052364 ³	1	
26	Nut, 5/16-18 Hex	F05010-17	1	
27	Bolt, 5/16-18 x 1 3/4" Hex Head Full Thread Grade 5	F05006-81	1	
	ROLLER ASSEMBLY, BLADE GUIDE (STANDARD FOR USE WITH 1 1/4" & 1 1/2" BLADES)	A04925 ²	1	
	ROLLER ASSEMBLY, EXTENDED BLADE GUIDE (OPTIONAL FOR USE WITH 1 1/2" BLADES)	014299 ²	1	
	Bearing Kit, Blade Guide Rebuild	K07079	1	
28	Washer, 5/8" White Felt	P04252	1	
29	Ring, 1 1/8" Interior Retaining	F04254-1	1	
30	Bearing, R8-2RS Blade Guide	015975	2	◆
31	Washer, 5/8" Gray Felt	P06455	1	
	Screw, 1/4-28 x 1/4" Socket Head Cup Point Set Black Oxide	F05005-105	1	
	Instruction Sheet, Blade Guide Rebuild	057407-1507	1	
32	Roller, Flanged Blade Guide (1 1/4" & 1 1/2" blade)	S04250	1	◆
	Roller, Flanged Blade Guide (1 1/2" blade)	014243	1	◆
	Instruction Sheet, Blade Guide Roller Replacement	A04925-364	1	
33	SPACER, 1/2" ID X 7/8" OD X 1/4" (FOR USE WITH 1 1/4" BLADES ONLY)	041626 ³	1	
34	BLOCK, BLADE GUIDE WEAR (STANDARD FOR 1 1/2" BLADES)	052309 ⁴	2	
	BLOCK, BLADE GUIDE WEAR (OPTIONAL FOR 1 1/4" BLADES)	052355	2	
	BLOCK ASSEMBLY, 1" SQ. EZ-GLIDE WEAR	036347	2	
35	ARM WELDMENT, DRIVE SIDE BLADE GUIDE	034292	1	
36	BOLT, BLADE GUIDE VERTICAL ADJUSTMENT	035656	1	
37	WASHER, 1/2" SPLIT LOCK	F05011-9	2	
38	BOLT, 1/2-13 X 1 1/2" HEX HEAD GRADE 5	F05008-33	2	
	SHIM, .008" BLADE GUIDE BLOCK SPACER	035248	1	
39	WASHER, 5/16" SAE FLAT	F05011-17	2	
40	WASHER, 5/16" SPLIT LOCK	F05011-13	2	
41	BOLT, 5/16-18 X 1 1/2" HEX HEAD STAINLESS STEEL	F05006-119	2	

2

Blade Guide Rollers & Arm

Blade Guide Assembly, Drive Side

	ROLLER ASSEMBLY, BLADE GUIDE RELUBE (OPTIONAL FOR USE WITH 1 1/4" & 1 1/2" BLADES)	016568 ²	1	
	ROLLER ASSEMBLY, EXTENDED BLADE GUIDE RELUBE (OPTIONAL FOR USE WITH 1 1/2" BLADES)	057405 ²	1	
	Bearing Kit, Relube Blade Guide Rebuild	057407	1	
42	Washer, 5/8" White Felt	P04252	1	
43	Ring, 1 1/8" Interior Retaining	F04254-1	1	
44	Bearing, R8-2RS Blade Guide	015975 ⁵	2	◆
45	Washer, 5/8" Gray Felt	P06455	1	
46	Spacer, Blade Guide Bearing	035411	1	
	Instruction Sheet, Blade Guide Rebuild	057407-1507	1	
47	Roller, Flanged Blade Guide (Relube 1 1/4" & 1 1/2" blade)	035426	1	◆
	Roller, Flanged Blade Guide (Relube 1 1/2" blade)	057402	1	◆
	Instruction Sheet, Blade Guide Roller Replacement	A04925-364	1	
48	BOLT, BLADE GUIDE ROLLER (RELUBE ONLY)	036161	1	
49	FITTING, 1/4-28 GREASE (RELUBE ONLY)	P05060	1	

¹ Nord-Lock Washer F05011-125 available to replace Split Lock Washer F05011-9 to prevent loosening due to vibration (12/09).

² The sawmill is equipped standard with non-greasable blade guide rollers that can be used with the standard 1 1/2" blade (requires spacer 052364). The roller can also be used with 1 1/4" blades (requires spacer 041626 & wear blocks 052355). Optional extended blade guide rollers are available for use with 1 1/2" blades (no spacer required). The extended rollers may provide more stability during difficult sawing, but will reduce the total amount of times the blade can be reused after sharpening. Optional relube versions of each roller configuration are also available.

³ Use 1/8" spacer 052364 with 1 1/2" blade provided as standard equipment. Use 1/4" spacer 041626 for optional 1 1/4" blades.

⁴ 052309 blocks for use with 1 1/2" blade provided as standard equipment. 052355 blocks available for optional use with 1 1/4" blades. EZ-Glide blocks 036347 are available for customers who prefer this block.

⁵ Bearing must be modified for use with relube roller assemblies. Remove one seal from each bearing, place open sides facing each other and place spacer 035411 between bearings.

2.4 Blade Guide Assembly, Drive Side

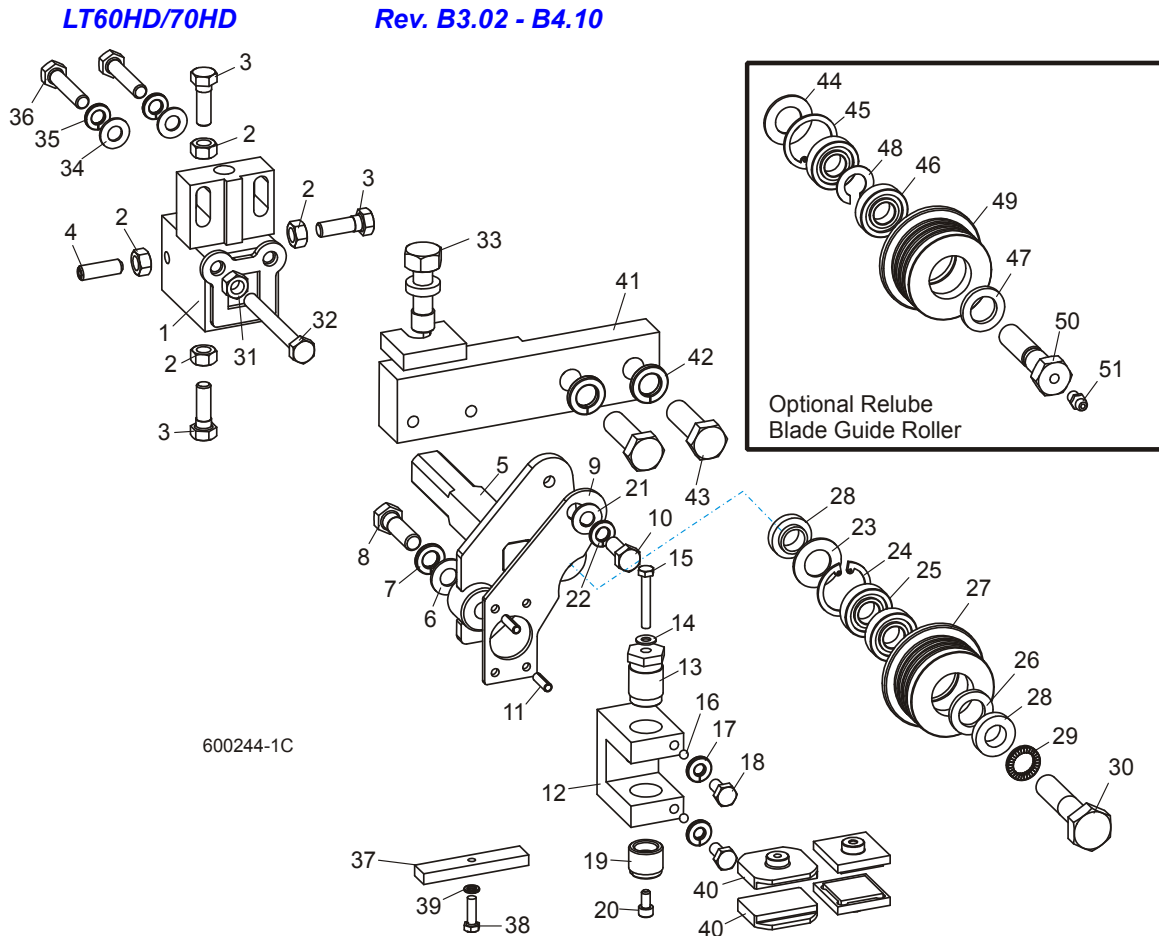

REF	DESCRIPTION (◆ Indicates Parts Available In Assemblies Only)	PART #	QTY.
	ROLLER/BLOCK ASSEMBLY, DRIVE SIDE (INNER)	003925 ¹	1
	Block Assembly, Blade Guide Mount	003910	1
1	Block Weldment, Blade Guide Mount	003911	1 ◆
2	Nut, 5/16-18 Hex	F05010-17	4
3	Bolt, 5/16-18 x 1" Hex Head Stainless Steel	F05006-88	3
4	Screw, 5/16-18 x 1" Socket Head Flat Point Stainless Steel Set	F05006-122	1
5	Shaft Weldment, Drive Side Guide	003913	1
	Mount Assembly, Blade Guide Block Drive	003927	1
6	Washer, 3/8" SAE Flat	F05011-3	1
7	Washer, 3/8" Split Lock	F05011-4	1
8	Bolt, 3/8-16 x 1 1/4" Hex Head Grade 5	F05007-123	1
9	Plate, Block Tilt Adjustment	003915	1
10	Bolt, 5/16-18 x 3/4" Hex Head	F05006-102	1
11	Pin, 3/16" x 5/8" Roll	F05012-22	2

2

Blade Guide Rollers & Arm

Blade Guide Assembly, Drive Side

12	Block, Guide Block Mount	003909	1	
13	Bolt, Blade Guide Block Mount	003994	1	
14	Washer, #10 Brass	042867	1	
15	Bolt, #10-32 x 1 1/4" Hex Head Stainless Steel	F05004-240	1	
16	Ball, 3/16" Dia. Nylon	003914	2	
17	Washer, 1/4" Split Lock	F05011-14	2	
18	Bolt, 1/4-20 x 1/2" Hex Head	F05005-15	2	
19	Screw, Lower Block Adjustment	044057	1	
20	Screw, #10-32 x 3/8" Socket Head Stainless Steel	F05004-200	1	
21	Washer, 5/16" SAE Flat	F05011-17	1	
22	Washer, 5/16" Split Lock	F05011-13	1	
	Roller Assembly, Blade Guide (standard for use with 1 1/4" & 1 1/2" blades)	A04925 ²	1	
	Roller Assembly, Extended Blade Guide (optional for use with 1 1/2" blades)	014299 ²	1	
	Bearing Kit, Blade Guide Rebuild	K07079	1	
23	Washer, 5/8" White Felt	P04252	1	
24	Ring, 1 1/8" Interior Retaining	F04254-1	1	
25	Bearing, R8-2RS Blade Guide	015975	2	◆
26	Washer, 5/8" Gray Felt	P06455	1	
	Screw, 1/4-28 x 1/4" Socket Head Cup Point Set Black Oxide	F05005-105	1	
	Instruction Sheet, Blade Guide Rebuild	057407-1507	1	
27	Roller, Flanged Blade Guide (1 1/4" & 1 1/2" blade)	S04250	1	◆
	Roller, Flanged Blade Guide (1 1/2" blade)	014243	1	◆
	Instruction Sheet, Blade Guide Roller Replacement	A04925-364	1	
28	Spacer, Blade Guide	S04253	2	
29	Washer, 1/2" Nord-Lock	F05011-125	1	
30	Bolt, 1/2-13 x 2 1/4" Hex Head Grade 5	F05008-10	1	
31	Nut, 5/16-18 Hex	F05010-17	1	
32	Bolt, 5/16-18 x 2 3/4" Hex Head Full Thread	F05006-136	1	
33	Bolt, Blade Guide Vertical Adjustment	035656	1	
34	Washer, 5/16" SAE Flat	F05011-17	2	
35	Washer, 5/16" Split Lock	F05011-13	2	
36	Bolt, 5/16-18 x 1 1/2" Hex Head	F05006-76	2	
37	BLOCK, BLADE GUIDE ALIGNMENT	035799	1	
38	SCREW, #10-32 X 5/8" HEX HEAD	F05004-152	1	
39	WASHER, #10 SPLIT LOCK	F05011-20	1	
40	BLOCK, BLADE GUIDE WEAR (STANDARD FOR 1 1/2" BLADES)	052309 ³	2	
	BLOCK, BLADE GUIDE WEAR (OPTIONAL FOR 1 1/4" BLADES)	052355 ³	2	
	BLOCK ASSEMBLY, 1" SQ. EZ-GLIDE WEAR	036347 ³	2	
41	ARM WELDMENT, DRIVE SIDE BLADE GUIDE	034292	1	
42	WASHER, 1/2" SPLIT LOCK	F05011-9	2	
43	BOLT, 1/2-13 X 1 1/2" HEX HEAD GRADE 5	F05008-33	2	
	SHIM, .008" BLADE GUIDE BLOCK SPACER	035248	1	

	ROLLER ASSEMBLY, BLADE GUIDE RELUBE (OPTIONAL FOR USE WITH 1 1/4" & 1 1/2" BLADES)	016568 ²	1	
	ROLLER ASSEMBLY, EXTENDED BLADE GUIDE RELUBE (OPTIONAL FOR USE WITH 1 1/2" BLADES)	057405 ²	1	
	Bearing Kit, Relube Blade Guide Rebuild	057407	1	
44	Washer, 5/8" White Felt	P04252	1	
45	Ring, 1 1/8" Interior Retaining	F04254-1	1	
46	Bearing, R8-2RS Blade Guide	015975 ⁴	2	◆
47	Washer, 5/8" Gray Felt	P06455	1	
48	Spacer, Blade Guide Bearing	035411	1	
	Instruction Sheet, Blade Guide Rebuild	057407-1507	1	
49	Roller, Flanged Blade Guide (Relube 1 1/4" & 1 1/2" blade)	035426	1	◆
	Roller, Flanged Blade Guide (Relube 1 1/2" blade)	057402	1	◆
	Instruction Sheet, Blade Guide Roller Replacement	A04925-364	1	
50	BOLT, BLADE GUIDE ROLLER (RELUBE ONLY)	036161	1	
51	FITTING, 1/4-28 GREASE (RELUBE ONLY)	P05060	1	

¹ 003925 Blade Guide Assembly replaced with 036812 Rev. B4.11. New assembly provides easier adjustment ([See Section 2.3](#)).

² The sawmill is equipped standard with non-greasable blade guide rollers that can be used with the standard 1 1/2" blade. The roller can also be used with 1 1/4" blades. Optional extended blade guide rollers are available for use with 1 1/2" blades. The extended rollers may provide more stability during difficult sawing, but will reduce the total amount of times the blade can be reused after sharpening. Optional relube versions of each roller configuration are also available.

³ 052309 blocks for use with 1 1/2" blade provided as standard equipment. 052355 blocks available for optional use with 1 1/4" blades. EZ-Glide blocks 036347 are available for customers who prefer this block.

⁴ Bearing must be modified for use with relube roller assemblies. Remove one seal from each bearing, place open sides facing each other and place spacer 035411 between bearings.

2 Blade Guide Rollers & Arm

Blade Guide Arm Drive Assembly

2.5 Blade Guide Arm Drive Assembly

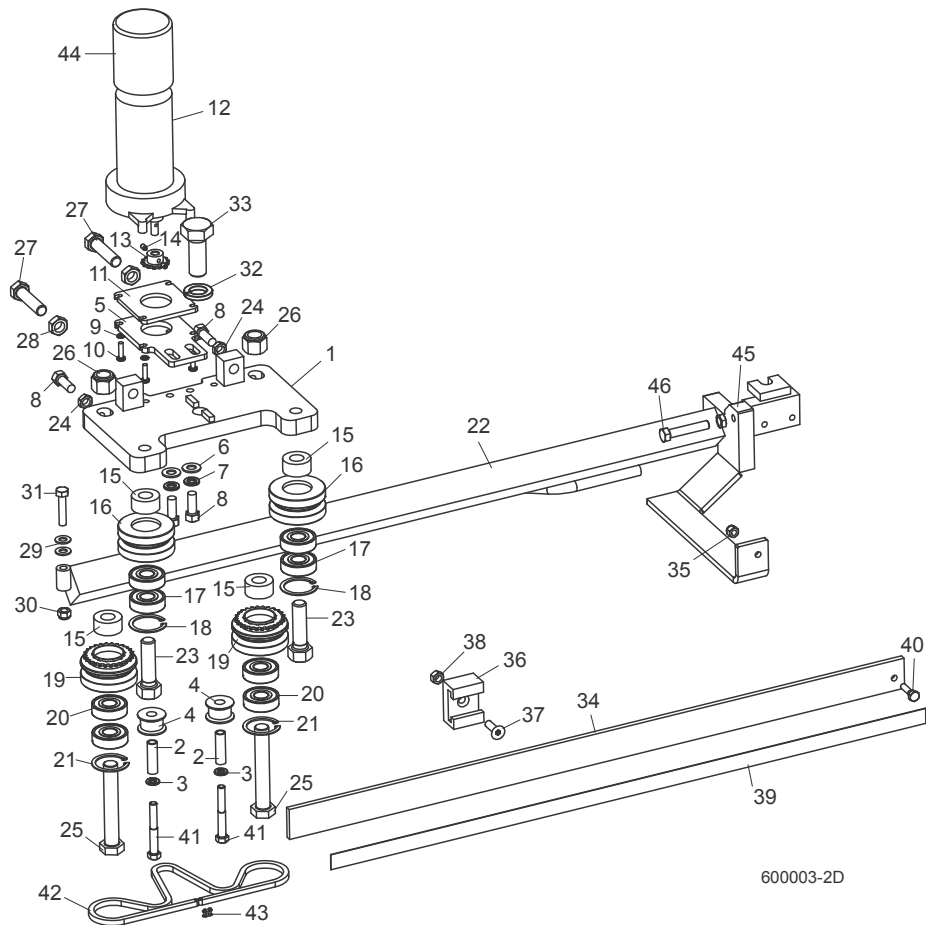

REF	DESCRIPTION (◆ Indicates Parts Available In Assemblies Only)	PART #	QTY.	
	ARM ASSEMBLY, IDLE SIDE BLADE GUIDE	034290	1	
	ARM ASSEMBLY, IDLE SIDE BLADE GUIDE (WIDE HEAD)	006163	1	
1	Plate Weldment, Blade Guide Arm	034286	1	
2	Spacer, .322" x .44" x 1 1/2"	S09996	2	
3	Washer, 5/16" Split Lock	F05011-13	2	
4	Roller, Blade Guide Drive	S09999	2	
5	Plate, Blade Guide Motor Mount	033803	1	
6	Washer, 3/8" SAE Flat	F05011-3	2	
7	Washer, 3/8" Split Lock	F05011-4	2	
8	Bolt, 3/8-16 x 1" Hex Head	F05007-7	4	
9	Washer, #10 Split Lock	F05011-20	4	
10	Screw, #10-32 x 3/4" Phillips Head Machine	F05004-38	4	
11	Plate, Blade Guide Motor Mount Spacer	033805	1	
12	Motor, Current Applications 1/30HP 12VDC Gear	079214 ¹	1	
	Gear Kit, Motor Replacement	061232	1	
	Brush Kit, Gear Motor Replacement	061234	1	

Blade Guide Rollers & Arm

Blade Guide Arm Drive Assembly

2

	Shaft Kit, Gear Motor Replacement	061233	1	
13	Sprocket Assembly, 25B14 x .3130	036664 ²	1	
14	Screw, #10-24 x 1/4" Full Dog Point Socket Set	F05004-274	2	
15	Spacer, Blade Guide Arm V-Roller	033913	4	
	Roller Assembly, Blade Guide Arm V Idle	042543	2	
16	Housing, 2 1/2" V-Groove	042536	1	
17	Bearing, 5/8" x 1.7548" x .4724"	P06030-1	2	
18	Ring, 1.575" ID Beveled 5002-156 Retaining	F04254-8	1	
	Roller Assembly, Blade Guide Arm V Drive	042542	2	
19	Housing, 2 1/2" V-Groove w/Sprocket	042541	1	
20	Bearing, 5/8" x 1.7548" x .4724"	P06030-1	2	
21	Ring, 1.575" ID Beveled 5002-156 Retaining	F04254-8	1	
22	Arm Weldment, Blade Guide	034289	1	
	Arm Weldment, Blade Guide (Wide Head)	006158	1	
23	Bolt, 5/8-18 x 2 1/4" Hex Head Grade 5	F05009-80	2	
24	Nut, 3/8-16 Hex Jam	F05010-29	2	
25	Bolt, 5/8-18 x 3 1/4" Hex Head Grade 5	F05009-98	2	
26	Nut, 5/8-18 Hex Nylon Lock	F05010-71	2	
27	Bolt, 1/2-20 x 2" Hex Head Full Thread	F05008-126	2	
28	Nut, 1/2-20 Hex Jam	F05010-16	2	
29	Washer, 5/16" SAE Flat	F05011-17	2	
30	Nut, 5/16-18 Hex Nylon Lock	F05010-58	1	
31	Bolt, 5/16-18 x 1 1/2" Hex Head Grade 5	F05008-96	1	
32	Washer, 3/4" Split Lock	F05011-6	1	
33	Bolt, 3/4-16 x 2" Full Thread Hex Head	F05013-1	1	
34	Guard, Blade Guide Arm	014955	1	
	Guard, Blade Guide Arm (Wide Head)	006266	1	
35	Nut, 1/4-20 Hex Nylon Lock	F05010-69	1	
36	Bracket, Blade Guide Arm Guide	014882	1	
37	Bolt, 5/16-18 x 1" Flat Head Socket	F05006-124	1	
38	Nut, 5/16-18 Hex Lock	F05010-6	1	
39	Decal, Blade Guide Arm Warning Stripe	015849	1	
40	Screw, 1/4-20 x 1" Hex Head	F05005-38	1	
41	Bolt, 5/16-18 x 2 1/2" Hex Head Grade 5	F05006-80	2	
42	Chain, #25 x 27 3/4"	036194	1	
43	Link, #25 Master	P09983	2	
44	Cap, 2.5" ID x 3" Rubber	023720	1	
45	Nut, 3/8-16 Hex Jam	F05010-29	1	
46	Bolt, 3/8-16 x 2" Hex Head Full Thread	F05007-16	1	

¹ Replaced P09698-1 1/30 HP 62RPM 12VDC 53:1 Gear Motor with P12756 End Housing, P12569 Gear Kit, P12800 Brush Kit and 009695 Shaft Kit (LT70 Rev. B6.12).

² Sprocket modified 6/11 with threaded holes to accept included set screws (replace 1/8" x 3/4" roll pin F05012-6).

SECTION 3 BLADE WHEELS & TENSIONER

3.1 Blade Drive Assembly

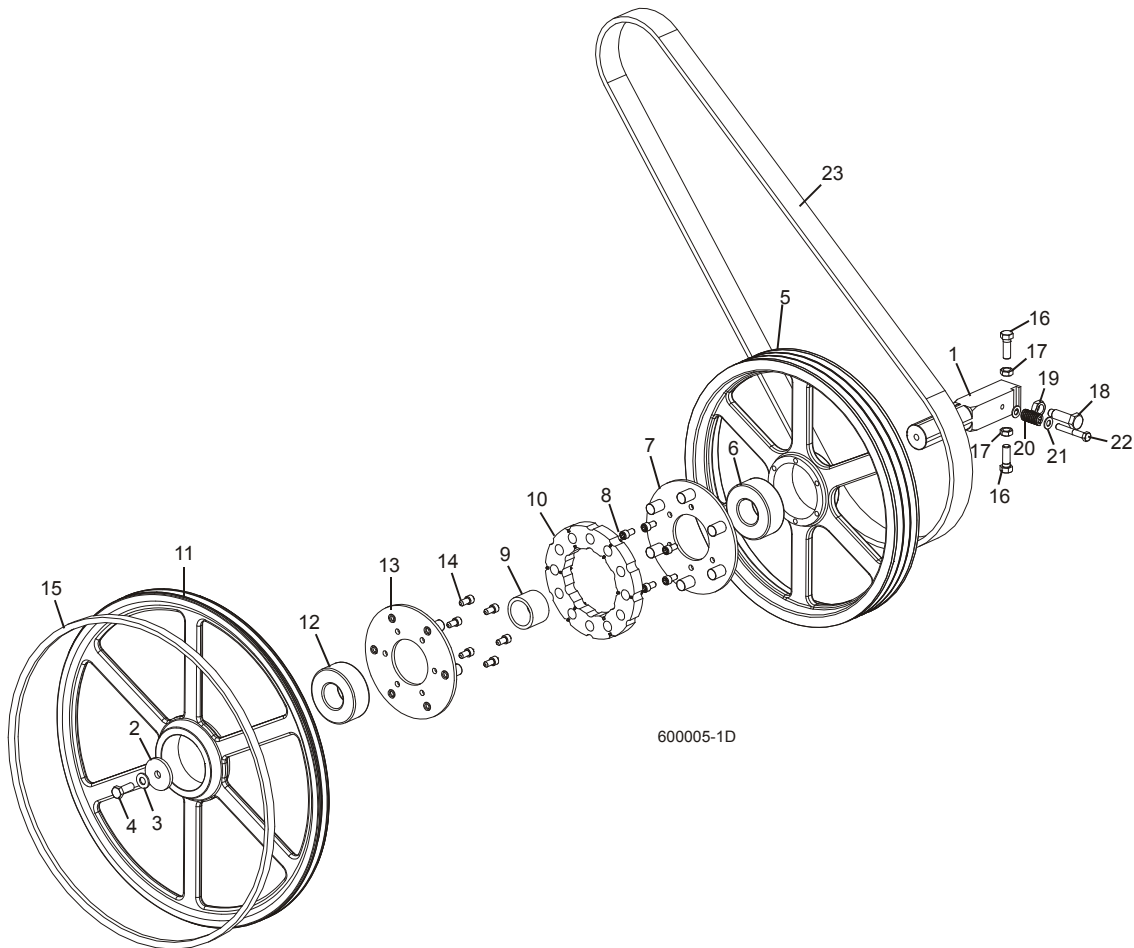

REF	DESCRIPTION (◆ Indicates Parts Available In Assemblies Only)	PART #	QTY.
	WHEEL ASSEMBLY, BLADE DRIVE	034359	1
1	Shaft, Blade Drive Wheel	033920	1
2	Washer, Blade Drive Wheel	033909	1
3	Washer, 1/2" SAE Flat	F05011-2	1
4	Bolt, 1/2-13 x 1 1/4" Hex Head Grade 5	F05008-37	1
	Pulley Assembly, 19" Blade Drive	034426	1
5	Pulley, Blade Drive	033809	1
6	Bearing, 5309-2RS	016014	1
7	Plate Assembly, Coupling	034424	1
8	Bolt, 3/8-24 x 3/4" Socket Head	F05007-154	6
9	Spacer, Drive Bearing	033921	1

Blade Wheel & Tensioner

Blade Drive Assembly

3

10	Ring, Drive Coupling	034418	1	
	Wheel Assembly, 24" Blade	017834	1	
11	Wheel, 24" Blade	034872	1	
12	Bearing, 5309-2RS	016014	1	
13	Plate Assembly, Coupling	034424	1	
14	Bolt, 3/8-24 x 3/4" Socket Head	F05007-154	6	
15	BELT, B72.5 BLADE WHEEL	017922-1 ¹	1	
16	BOLT, 1/2-20 X 1 1/2" HEX HEAD GRADE 5	F05008-53	2	
17	NUT, 1/2-20 HEX JAM	F05010-16	2	
18	BOLT, DRIVE WHEEL RETAINING	034360	1	
19	NUT, 5/8-18 HEX JAM	F05010-11	1	
20	SPRING, 3/4" OD X 1 1/2" LONG DIE	034430	1	
21	WASHER, 3/8" SAE FLAT	F05011-3	2	
22	BOLT, 3/8-16 X 2 1/2" HEX HEAD GRADE 5	F05007-125	1	
23	BELT, DRIVE (SEE ENGINE MANUAL FOR PART #)	<u>SEE ENGINE OPTION</u>	1	

¹ 017922-1 B72.5 Belt replaces 017922 supplied prior to Rev. B4.01. New belt provides longer service life.

3 Blade Wheels & Tensioner

Idle Blade Wheel Assembly

3.2 Idle Blade Wheel Assembly

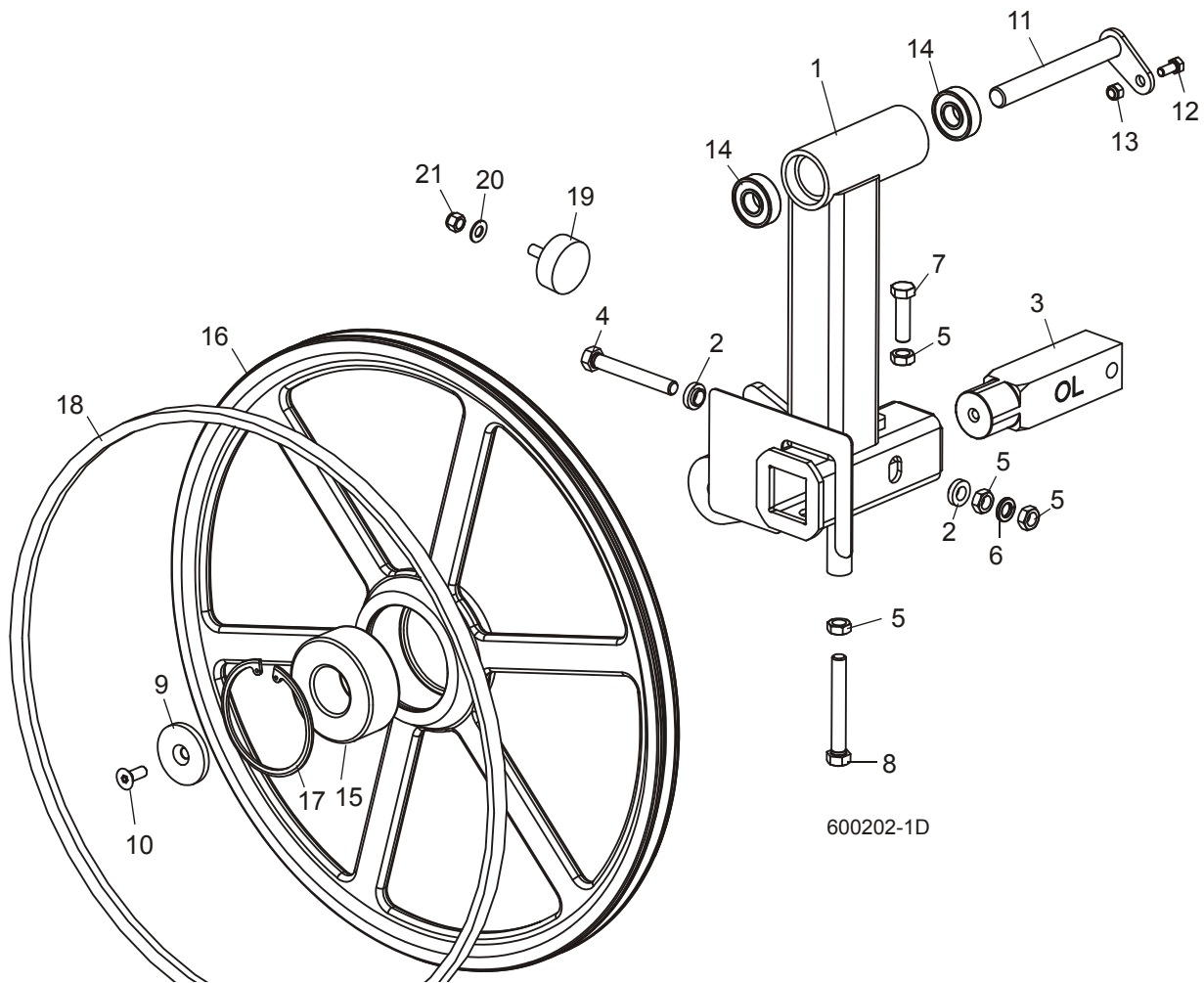

REF	DESCRIPTION (◆ Indicates Parts Available In Assemblies Only)	PART #	QTY.
	SHAFT ASSEMBLY, IDLE BLADE WHEEL (CAM TENSIONER)	036729	1
1	Tube Weldment, Idle Side Blade Wheel	048266	1
2	Spacer, .510" x .937" x .34"	S04253	2
3	Shaft, Idle Side Blade Wheel	017706	1
4	Bolt, 1/2-20 x 3 3/4" Hex Head Full Thread Grade 5	F05008-111	1
5	Nut, 1/2-20 Hex Jam	F05010-16	4
6	Washer, 1/2" Split Lock	F05011-9	1
7	Bolt, 1/2-20 x 1 3/4" Hex Head Full Thread	F05008-127	1
8	Bolt, 1/2-20 x 3 3/4" Hex Head Full Thread Grade 5	F05008-111	1
9	Washer, 3/32" ID x 2 1/4" OD x 1/4" Thick	016397	1
10	Bolt, 3/8-16 x 1" Flat Socket Head	F05007-64	1
11	Pin Weldment, Idle Wheel Pivot	034358	1
12	Bolt, 5/16-18 x 3/4" Hex Head	F05006-102	1
13	Nut, 5/16-18 Hex Nylon Lock	F05010-58	1

Blade Wheels & Tensioner

Idle Blade Wheel Assembly

3

14	Bearing, #465966	034470	2	
	WHEEL ASSEMBLY, 24" IDLE BLADE	017835	1	
15	Bearing, 5309-2RS	016014	1	
16	Wheel, 24" Blade	034871	1	
17	Ring, 100 mm Beveled Inside Retaining	F04254-28	1	
18	BELT, B72.5 BLADE WHEEL	017922-1 ¹	1	
19	BUMPER, TABLE	034175	1	
20	WASHER, 3/8" FLAT SAE	F05011-3	1	
21	NUT, 3/8-16 HEX NYLON LOCK	F05010-10	1	

¹ 017922-1 B72.5 Belt replaces 017922 supplied prior to Rev. B4.01. New belt provides longer service life.

3 Blade Wheels & Tensioner

Hydraulic Blade Tensioner Assembly

3.3 Hydraulic Blade Tensioner Assembly

LT70HD Rev. B6.05+
 LT70HD Rev. A4.01+

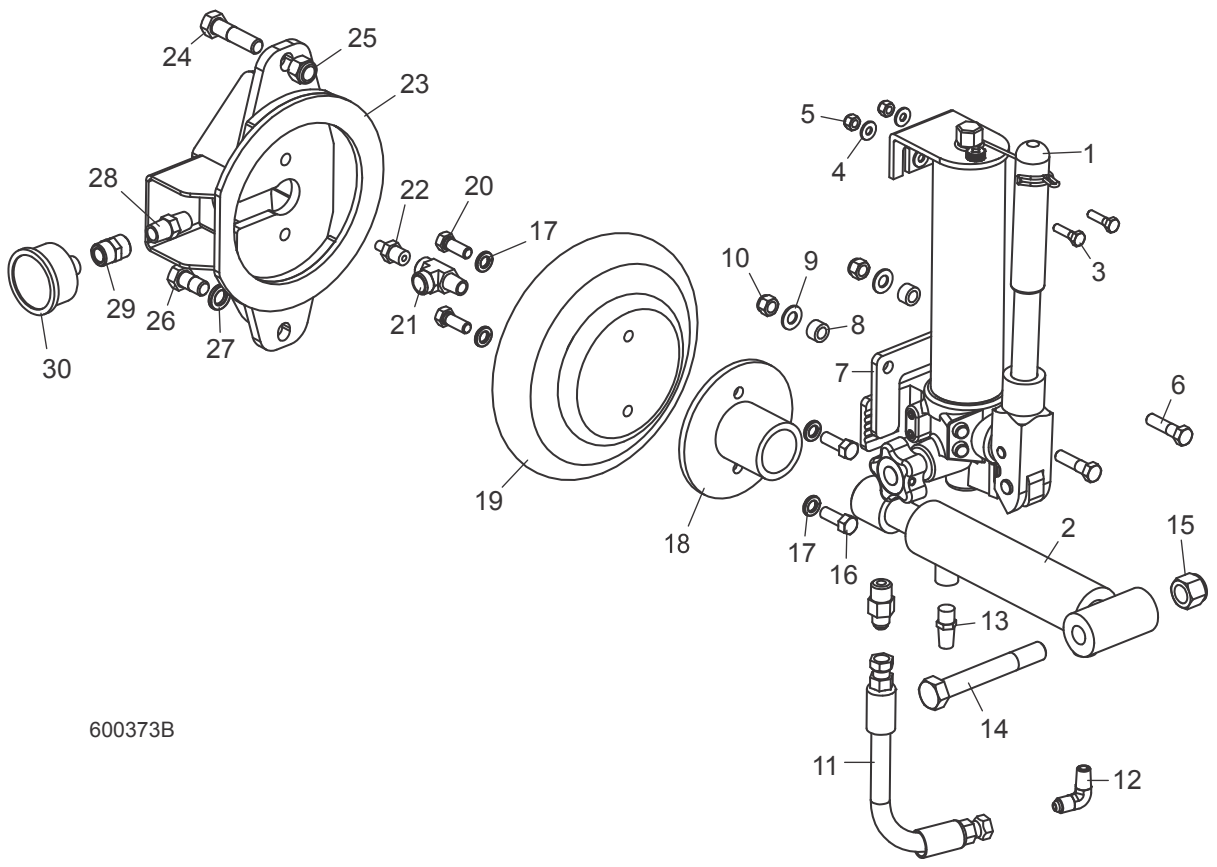

600373B

REF	DESCRIPTION (◆ Indicates Parts Available In Assemblies Only)	PART #	QTY.	
1-30	TENSIONER ASSEMBLY, LT70 HYDRAULIC BLADE	054844	1	◆
1-13	Tensioner Assembly, LT70 Hydraulic Hand Pump	074809	1	
1	Pump, 2850 PSI 20cu in Hydraulic Hand	074749	1	
	Kit, Seal Hyd Blade Tensioner LT70 P20	061287	1	
	Knob, Tensioner Pressure Release LT70P20	061288	1	
	Screw, Release Knob Set	061289	1	
2	Cylinder, 1 1/2" x 6" In-Line Ports	065478	1	
3	Bolt, 1/4-20 x 1" Hex Head Grade 5	F05005-101	2	
4	Washer, 1/4" SAE Flat	F05011-11	4	
5	Nut, 1/4-20 Nylock	F05010-69	2	
6	Bolt, 3/8-16 x 1 1/2" Hex Head Grade 5	F05007-78	2	
7	Plate, Hand Pump Brace	074808	1	
8	Spacer, .39x.625x.39	055323	2	
9	Washer, 3/8" Flat SAE	F05011-3	2	

Blade Wheels & Tensioner

Hydraulic Blade Tensioner Assembly

3

10	Nut, 3/8-16 Hex Nyloc	F05010-10	2	
11	Hose, 3/8x9 Hyd w/2 St Swivel Fittings	079001-9	1	
12	Fitting, 3/8" JIC-1/4" NPT 90L	015491	1	
13	Muffler, 1/4" NPT Air	P20904	1	
14	Bolt, 5/8-11 x 4 1/2" Hex Head Grade 5	F05009-10	1	
15	Nut, 5/8-11 Hex Nylon Lock	F05010-34	1	
16	Bolt, 3/8-16 x 1" Hex Head	F05007-7	2	
17	Washer, 3/8" Split Lock	F05011-4	4	
18	Tube Weldment, Tensioner	055317	1	
19	Bag, Blade Tensioner Air	033984	1	
20	Bolt, 3/8-16 x 1" Hex Head Grade 5	F05007-87	2	
21	Fitting, 1/4" NPT x 1/4" JIC Male Run Tee	P09141	1	
22	Fitting, 1/4" NPT Air Valve	034285	1	
23	Plate Weldment, Air Bag Mount	034276	1	
24	Bolt, 1/2-13 x 2" Hex Head	F05008-76	1	
25	Nut, 1/2-13 Hex Nylon Lock	F05010-8	1	
26	Bolt, 1/2-13 x 1" Hex Head	F05008-50	1	
27	Washer, 1/2" Split Lock	F05011-9	1	
28	Fitting, 1/4" NPT Hex Nipple	P21524	1	
29	Fitting, 1/4" NPT Coupling	P03420	1	
30	Gauge, Liquid-Filled Air	034278	1	

3 Blade Wheels & Tensioner

Hydraulic Blade Tensioner Assembly

3.4 Hydraulic Blade Tensioner Assembly

LT70HD
LT70HD

Rev. B4.08 - B6.04
Rev. A1.00 - A4.00

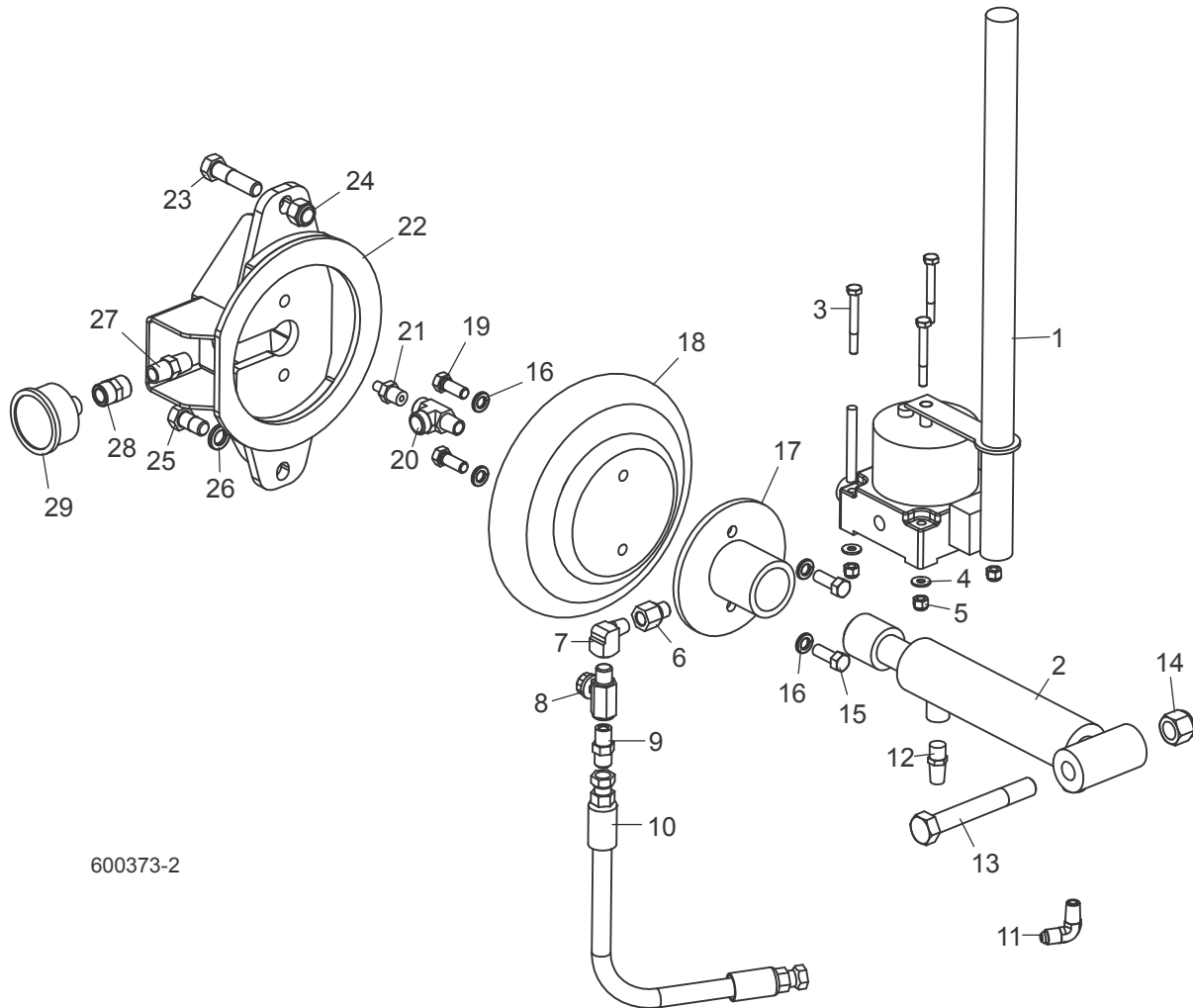

600373-2

REF	DESCRIPTION (◆ Indicates Parts Available In Assemblies Only)	PART #	QTY.	
1-29	TENSIONER ASSEMBLY, LT70 HYDRAULIC BLADE	054844 ¹	1	◆
1-12	Tensioner Assembly, 2012 LT70 Hydraulic	065681	1	
1	Pump, Hydraulic Hand, 6000 PSI 3.3cc Disp	069580	1	
	Seal Kit, LT70 Hydraulic Tensioner (For 069580)	061133	1	
2	Cylinder, 1 1/2" x 6" In-Line Ports	065478	1	
3	Screw, 1/4-20 x 2 1/4" Hex Head Cap Grade 5	F05005-72	4	
4	Washer, 1/4" SAE Flat	F05011-11	4	
5	Nut, 1/4-20 Nylock	F05010-69	4	
6	Fitting, 6" SAE Male-1/4" NPT Female	014686	1	

Blade Wheels & Tensioner

Hydraulic Blade Tensioner Assembly

3

7	Fitting, 1/4" 90 Deg Brass Street Elbow	P05383	1	
8	Valve, Hydraulic Cut-Off	P22314	1	
9	Fitting, 3/8" JIC-1/4" NPT Str	015560	1	
10	Hose Assembly, 3/8" x 12" Hydraulic	065537	1	
11	Fitting, 3/8" JIC-1/4" NPT 90L	015491	1	
12	Muffler, 1/4" NPT Air	P20904	1	
13	Bolt, 5/8-11 x 4 1/2" Hex Head Grade 5	F05009-10	1	
14	Nut, 5/8-11 Hex Nylon Lock	F05010-34	1	
15	Bolt, 3/8-16 x 1" Hex Head	F05007-7	2	
16	Washer, 3/8" Split Lock	F05011-4	4	
17	Tube Weldment, Tensioner	055317	1	
18	Bag, Blade Tensioner Air	033984	1	
19	Bolt, 3/8-16 x 1" Hex Head Grade 5	F05007-87	2	
20	Fitting, 1/4" NPT x 1/4" JIC Male Run Tee	P09141	1	
21	Fitting, 1/4" NPT Air Valve	034285	1	
22	Plate Weldment, Air Bag Mount	034276	1	
23	Bolt, 1/2-13 x 2" Hex Head	F05008-76	1	
24	Nut, 1/2-13 Hex Nylon Lock	F05010-8	1	
25	Bolt, 1/2-13 x 1" Hex Head	F05008-50	1	
26	Washer, 1/2" Split Lock	F05011-9	1	
27	Fitting, 1/4" NPT Hex Nipple	P21524	1	
28	Fitting, 1/4" NPT Coupling	P03420	1	
29	Gauge, Liquid-Filled Air	034278	1	

¹ Tensioner Assembly 054844 modified 10/15. 069580 Hydraulic Tensioner Service Block Kit no longer available. Use 074816 Blade Tensioner Retrofit Kit.

3 Blade Wheels & Tensioner

Hydraulic Blade Tensioner Assembly

3.5 Hydraulic Blade Tensioner Assembly

LT70HD Remote

Rev. B4.00 -B4.07

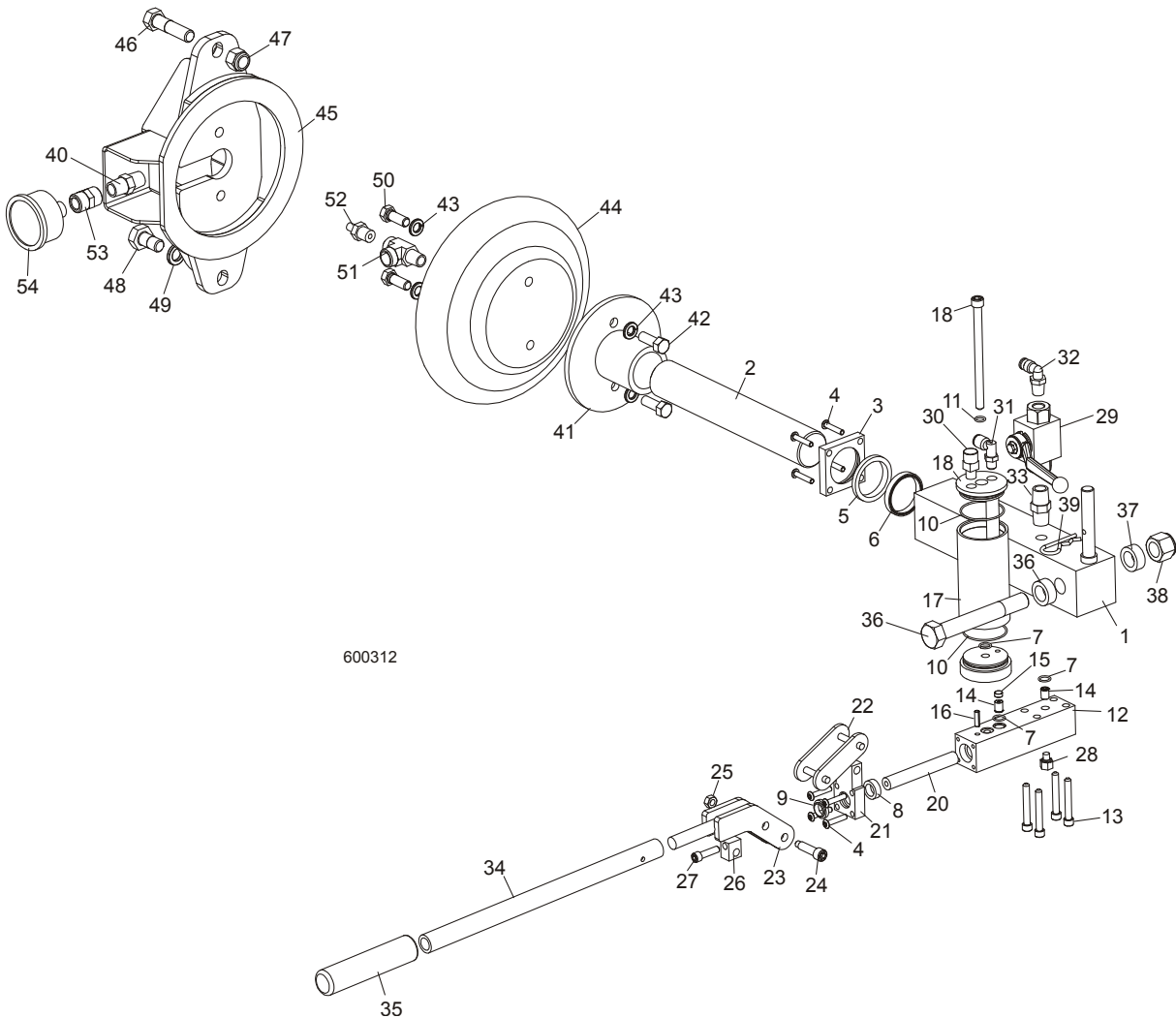

REF	DESCRIPTION (◆ Indicates Parts Available In Assemblies Only)	PART #	QTY.	
1-54	TENSIONER ASSEMBLY, LT70 HYDRAULIC BLADE	054844 ¹	1	◆
1-33	Block Kit, Hydraulic Tensioner Service	006529 ¹	1	
1-28	Block Assembly, Hydraulic Blade Tensioner	055315	1	◆
1	Block Weldment, Tensioner Cylinder	056809	1	
2	Rod, Tensioner Push	054848	1	
3	Block, Tensioner Push Rod Wiper	054846	1	
4	Screw, #10-24 x 1" Socket Button Head	F05004-43	8	
5-11	Seal Kit, Hydraulic Tensioner Service	006528	1	
5	Wiper, 1 1/2" Rod	056884	1	◆

Blade Wheels & Tensioner Hydraulic Blade Tensioner Assembly

3

6	Seal, 1 1/2" Loaded Lip	056887	1	◆
7	O-Ring, 1/16" x 3/8" ID x 1/2" OD	056888	3	◆
8	Seal, 1/2" Loaded Lip	056886	1	◆
9	Wiper, 1/2" Rod	056885	1	◆
10	O-Ring, 1/16" x 1 5/8" ID x 1 3/4" OD	056889	2	◆
11	O-Ring, 5/16" ID x 7/16" OD #011	033477	1	◆
	Inst. Sheet, LT70 Hydraulic Blade Tensioner Seal Replacement	006825-1601	1	
12	Block, Tensioner Piston	054845	1	
13	Screw, 1/4-20 x 1 3/4" Socket Head	F05005-156	4	
14	Valve, 8mm Check	056883	2	
15	Screen, Hydraulic Cartridge	006274	1	
16	Pin, 3/16" x 5/8" Roll	F05012-22	1	
17	Tube, Hydraulic Fluid Tank	054837	1	
18	Cap Weldment, Hydraulic Reservoir	006366	1	
19	Screw, 5/16-18 x 4 1/2" Socket Head	F05006-135	1	
20	Rod, Tensioner Piston	054842	1	
21	Block, Tensioner Pivot Link	054843	1	
22	Link, C2080H Master	016796	1	
23	Link Weldment, Tensioner Pivot	055316	1	
24	Screw, 5/16" x 1" (1/4-20 Thread) Socket Head Shoulder	F05006-41	1	
25	Nut, 1/4-20 Hex Lock	F05010-21	1	
26	Block, Piston Link	054840	1	
27	Screw, 1/4-20 x 1" Socket Head	F05005-89	1	
28	Plug, 5/16-24 x 5/8" O-Ring	P10065	1	
29	Valve, 7250 PSI Hydraulic	056806	1	
30	Fitting, 1/8" NPT Protected Vent	056890	1	
31	Fitting, 1/4" NPT x 1/4" Tube 90° Elbow	P21519	1	
32	Fitting, 1/8" MPT x 1/4" Tube Swivel Elbow	P09736	1	
33	Fitting, 1/4" NPT Hex Nipple	P21524	1	
34	Tube, Tensioner Handle	055318	1	
35	Grip, 3/4" ID x 4 1/2" Handle	049031	1	
36	Bolt, 5/8-11 x 4 1/2" Hex Head Grade 5	F05009-10	1	
37	Spacer, 5/8" ID x 1" OD x 13/32"	056900	2	
38	Nut, 5/8-11 Hex Nylon Lock	F05010-34	1	
39	Pin, 1/8" x 1 13/16" Safety	P05059	1	
40	Fitting, 1/4" NPT Hex Nipple	P21524	1	
41	Tube Weldment, Tensioner	055317	1	
42	Bolt, 3/8-16 x 1" Hex Head	F05007-7	2	
43	Washer, 3/8" Split Lock	F05011-4	4	
44	Bag, Blade Tensioner Air	033984	1	
45	Plate Weldment, Air Bag Mount	034276	1	
46	Bolt, 1/2-13 x 2" Hex Head	F05008-76	1	
47	Nut, 1/2-13 Hex Nylon Lock	F05010-8	1	

3**Blade Wheels & Tensioner**
Hydraulic Blade Tensioner Assembly

48	Bolt, 1/2-13 x 1" Hex Head	F05008-50	1	
49	Washer, 1/2" Split Lock	F05011-9	1	
50	Bolt, 3/8-16 x 1" Hex Head Grade 5	F05007-87	2	
51	Fitting, 1/4" NPT x 1/4" JIC Male Run Tee	P09141	1	
52	Fitting, 1/4" NPT Air Valve	034285	1	
53	Fitting, 1/4" NPT Coupling	P03420	1	
54	Gauge, Liquid-Filled Air	034278	1	

¹ Tensioner Assembly 054844 modified 10/15. 006529 Hydraulic Tensioner Service Block Kit no longer available. Use 074819 Blade Tensioner Retrofit Kit.

3.6 Hydraulic Blade Tensioner Assembly

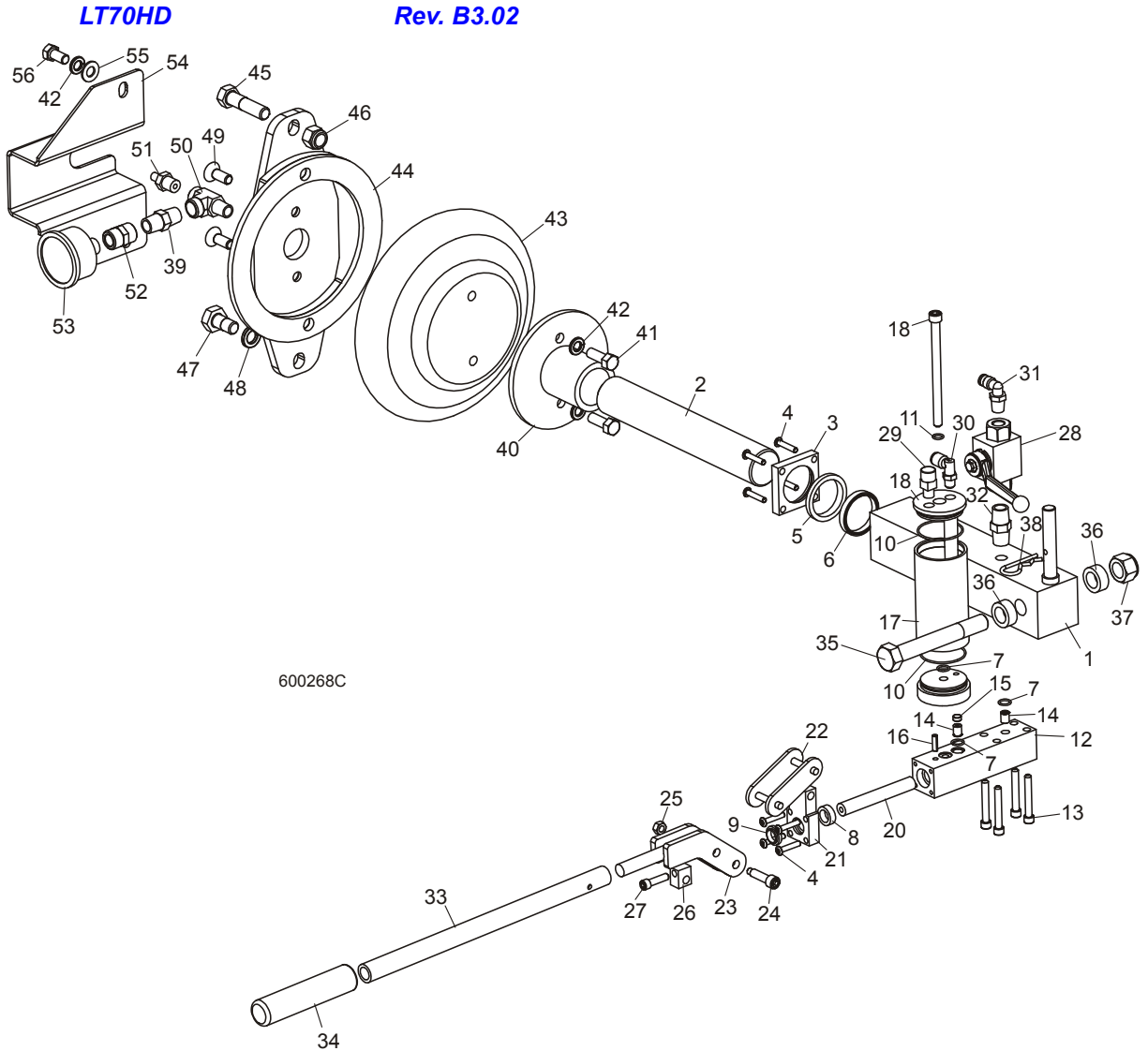

REF	DESCRIPTION (◆ Indicates Parts Available In Assemblies Only)	PART #	QTY.	
1-56	TENSIONER ASSEMBLY, LT70 HYDRAULIC BLADE	054844 ¹	1	◆
1-32	Block Kit, Hydraulic Tensioner Service	006529 ¹	1	
1-27	Block Assembly, Hydraulic Blade Tensioner	055315 ¹	1	◆
1	Block Weldment, Tensioner Cylinder	056809	1	
2	Rod, Tensioner Push	054848	1	
3	Block, Tensioner Push Rod Wiper	054846	1	
4	Screw, #10-24 x 1" Socket Button Head	F05004-43	8	
5-11	Seal Kit, Hydraulic Tensioner Service	006528	1	
5	Wiper, 1 1/2" Rod	056884	1	◆

3

Blade Wheels & Tensioner Hydraulic Blade Tensioner Assembly

6	Seal, 1 1/2" Loaded Lip	056887	1	◆
7	O-Ring, 1/16" x 3/8" ID x 1/2" OD	056888	3	◆
8	Seal, 1/2" Loaded Lip	056886	1	◆
9	Wiper, 1/2" Rod	056885	1	◆
10	O-Ring, 1/16" x 1 5/8" ID x 1 3/4" OD	056889	2	◆
11	O-Ring, 5/16" ID x 7/16" OD #011	033477	1	◆
	Inst. Sheet, LT70 Hydraulic Blade Tensioner Seal Replacement	006825-1601	1	
12	Block, Tensioner Piston	054845 ¹	1	
13	Screw, 1/4-20 x 1 3/4" Socket Head	F05005-156	4	
14	Valve, 8mm Check	056883	2	
15	Screen, Hydraulic Cartridge	006274	1	
16	Pin, 3/16" x 5/8" Roll	F05012-22	1	
17	Tube, Hydraulic Fluid Tank	054837	1	
18	Cap Weldment, Hydraulic Reservoir	006366	1	
19	Screw, 5/16-18 x 4 1/2" Socket Head	F05006-135	1	
20	Rod, Tensioner Piston	054842	1	
21	Block, Tensioner Pivot Link	054843	1	
22	Link, C2080H Master	016796	1	
23	Link Weldment, Tensioner Pivot	055316	1	
24	Screw, 5/16" x 1" (1/4-20 Thread) Socket Head Shoulder	F05006-41	1	
25	Nut, 1/4-20 Hex Lock	F05010-21	1	
26	Block, Piston Link	054840	1	
27	Screw, 1/4-20 x 1" Socket Head	F05005-89	1	
28	Valve, 7250 PSI Hydraulic	056806	1	
29	Fitting, 1/8" NPT Protected Vent	056890	1	
30	Fitting, 1/4" NPT x 1/4" Tube 90° Elbow	P21519	1	
31	Fitting, 1/8" MPT x 1/4" Tube Swivel Elbow	P09736	1	
32	Fitting, 1/4" NPT Hex Nipple	P21524	1	
33	Tube, Tensioner Handle	055318	1	
34	Grip, 3/4" ID x 4 1/2" Handle	049031	1	
35	Bolt, 5/8-11 x 4 1/2" Hex Head Grade 5	F05009-10	1	
36	Spacer, 5/8" ID x 1" OD x 13/32"	056900	2	
37	Nut, 5/8-11 Hex Nylon Lock	F05010-34	1	
38	Pin, 1/8" x 1 13/16" Safety	P05059	1	
39	Fitting, 1/4" NPT Hex Nipple	P21524	1	
40	Tube Weldment, Tensioner	055317	1	
41	Bolt, 3/8-16 x 1" Hex Head	F05007-7	2	
42	Washer, 3/8" Split Lock	F05011-4	4	
43	Bag, Blade Tensioner Air	033984	1	
44	Plate Weldment, Air Bag Mount	034276 ¹	1	
45	Bolt, 1/2-13 x 2" Hex Head	F05008-76	1	
46	Nut, 1/2-13 Hex Nylon Lock	F05010-8	1	
47	Bolt, 1/2-13 x 1" Hex Head	F05008-50	1	

Blade Wheels & Tensioner

Hydraulic Blade Tensioner Assembly

3

48	Washer, 1/2" Split Lock	F05011-9	1	
49	Screw, 3/8-16 x 1" Flat Socket Head	F05007-64	2	
50	Fitting, 1/4" NPT x 1/4" JIC Male Run Tee	P09141	1	
51	Fitting, 1/4" NPT Air Valve	034285	1	
52	Fitting, 1/4" NPT Coupling	P03420	1	
53	Gauge, Liquid-Filled Air	034278	1	
54	Guard, Air Gauge	034245 ¹	1	
55	Washer, 3/8" SAE Flat	F05011-3	2	
56	Bolt, 3/8-16 x 3/4" Hex Head	F05007-27	2	

¹ Tensioner Assembly 054844 modified 10/15. 006529 Hydraulic Tensioner Service Block Kit no longer available. Use 074819 Blade Tensioner Retrofit Kit.

4 Saw Head
Middle Throat Screw

SECTION 4 SAW HEAD FRAME

4.1 Middle Throat Screw

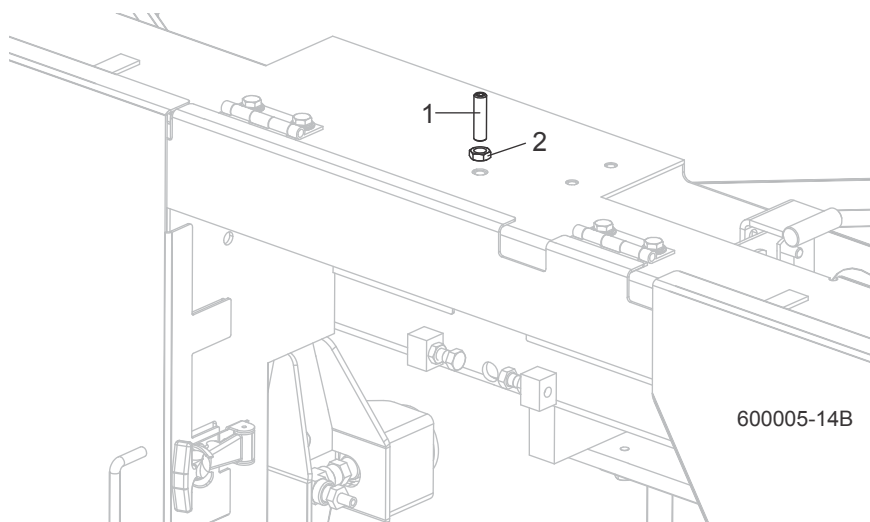

REF	DESCRIPTION (◆ Indicates Parts Available In Assemblies Only)	PART #	QTY.	
1	SCREW, 3/8-16 X 1 1/2" OVAL POINT SOCKET SET	F05007-190	1	
2	NUT, 3/8-16 HEX JAM	F05010-29	1	

4.2 Belt Tensioner

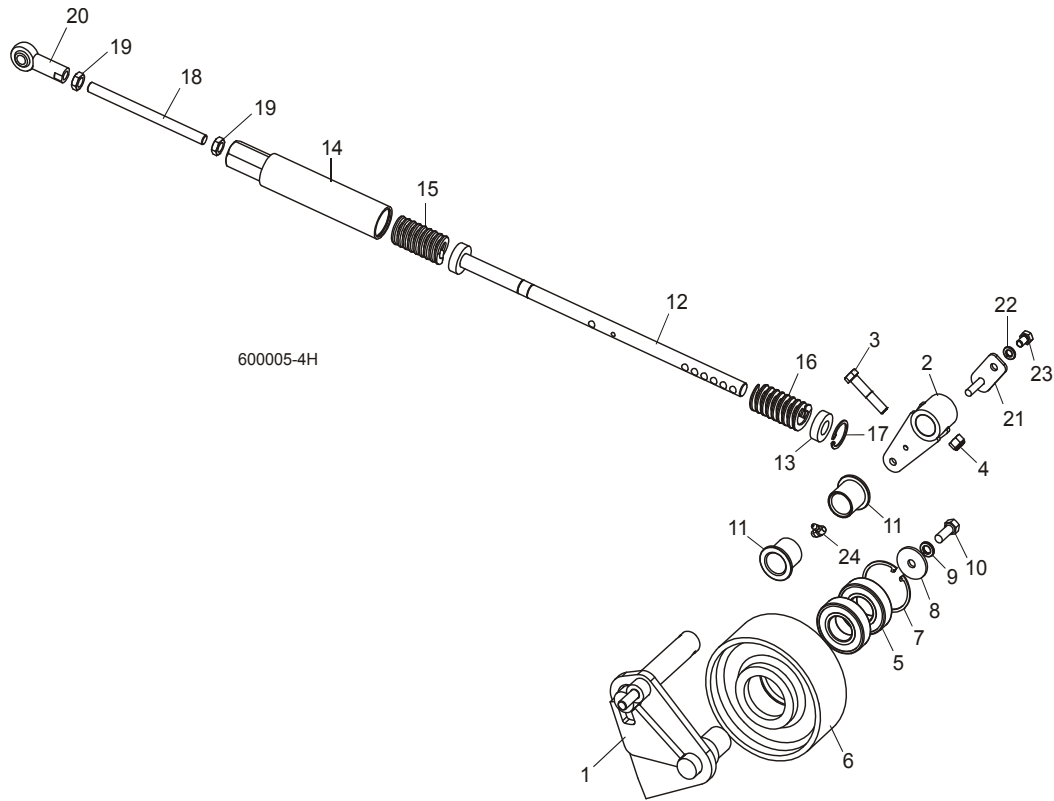

REF	DESCRIPTION (◆ Indicates Parts Available In Assemblies Only)	PART #	QTY.
	TENSIONER ASSEMBLY, DRIVE BELT	034894	1
	Pivot Kit, Drive Belt Tensioner Retrofit	038934	1
1	Arm Weldment, Drive Belt Tensioner	034893	1
2	Pivot Weldment, Drive Belt Tensioner	034593	1
	Instruction Sheet, Tensioner Pivot Retrofit	038934-1265	1
3	Bolt, 3/8-16 x 2" Hex Head Grade 5	F05007-124	1
4	Nut, 3/8-16 Hex Nylon Lock	F05010-10	1
5	Bearing, 6206 25" Idler	P11035	2
6	Idler, Drive Belt	033941	1
7	Ring, 62mm Inside Retaining	F04254-12	1
8	Washer, 3/8" x 1 1/2" x 1/8"	F05011-104	1
9	Washer, 3/8" Split Lock	F05011-4	1
10	Bolt, 3/8-16 x 1" Hex Head	F05007-7	1
11	Bushing, 1" ID x 1 1/4" OD Flanged	P109	2
	Rod Kit, Drive Belt Tensioner	003193	1
12	Rod Weldment, Drive Belt Tensioner	017923	1
13	Washer, Tensioner	034674	1

4

Saw Head

Belt Tensioner

14	Tube Weldment, Drive Belt Tensioner	034689	1	
	Spring Kit, Belt Tensioner Retrofit	036501	1	
15	Spring, 1 1/4" OD x 2 1/2" Die, Heavy	036136	1	
16	Spring, 1 1/4" OD x 2 1/2" Die, Medium (Blue)	065242 ¹	1	
	Instruction Sheet, Belt Tensioner Spring Retro	036501-1148	1	
17	Ring, 1 15/16" Inside Retaining	F04254-44	1	
18	Rod, 7/16-20 x 6" Threaded	017924	1	
19	Nut, 7/16-20 Hex Jam	F05010-38	2	
20	Rod End, 7/16-20 Right Hand Female	017925	1	
21	Pin Weldment, Drive Belt Tensioner	034673	1	
22	Washer, 5/16" Split Lock	F05011-13	1	
23	Bolt, 5/16-18 x 1/2" Hex Head Grade 5	F05006-15	1	
24	FITTING, 1/4-28 90 DEG. GREASE	P04108	1	

¹ Added Rev. B4.04 to replace 1 1/4" OD x 2 1/2" Die Heavy Spring (036136).

4.3 Brake Assembly (DC Only)

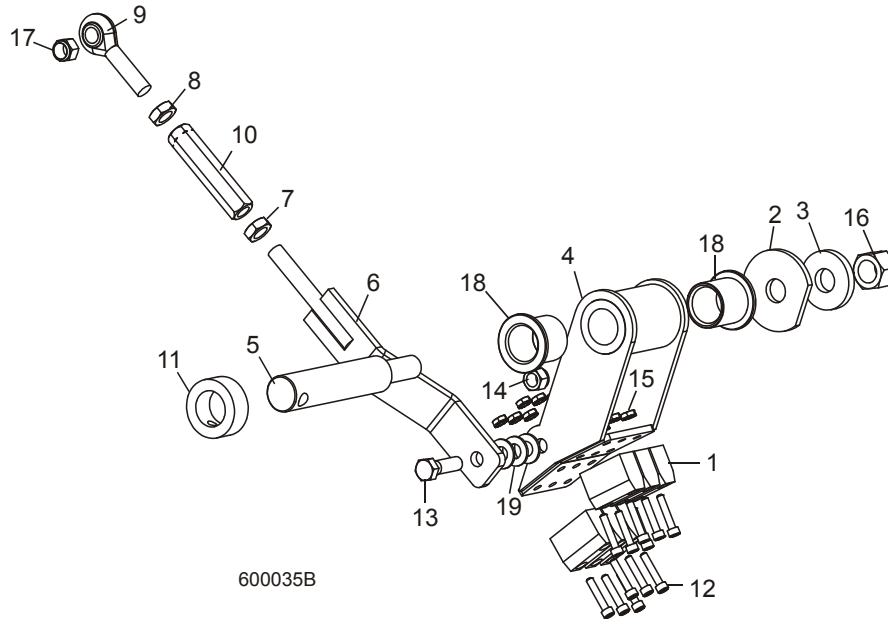

REF	DESCRIPTION (◆ Indicates Parts Available In Assemblies Only)	PART #	QTY.
	BRAKE ASSEMBLY, LT60/70	034886	1
1	Block, Blade Wheel Brake	016488	6
2	Washer, 21/32" x 2 1/4" x 3/16"	017838	1
3	Washer, 21/32" x 1 5/8" x 1/4"	034685	1
4	Arm Weldment, Pivot Brake	034883	1
5	Shaft, Pivot Brake	034885	1
	Linkage Assembly, Pivot Brake	034892	1
6	Arm Weldment, Pivot Brake Lik	034891	1
7	Nut, 7/16-20 Jam	F05010-38	1
8	Nut, 7/16-20 Left Hand Jam	F05010-87	1
9	Rod End, 7/16-20 Left Hand Male	P11578	1
10	Turnbuckle, 3" Adjustment	S11577	1
11	Collar, 1" Lock	038090	1
12	Bolt, #10-24 x 1" Socket Head	F05004-2	12
13	Bolt, 3/8-16 x 1 1/4" Hex Head Grade 5	F05007-123	1
14	Nut, 3/8-16 Hex Nylon Lock	F05010-10	1
15	Nut, #10-24 Self-Locking Hex	F05010-14	12
16	Nut, 5/8-18 Hex Nylon Lock	F05010-71	1
17	Nut, 7/16-20 Hex Nylon Lock	F05010-83	1
18	Bushing, 1" ID x 1 1/4" OD Flanged	P109	2
19	Washer, 3/8" SAE Flat	F05011-3	3

4 Saw Head

Autoclutch Assembly (DC Only)

4.4 Autoclutch Assembly (DC Only)

LT70HD

Rev. B4.00+

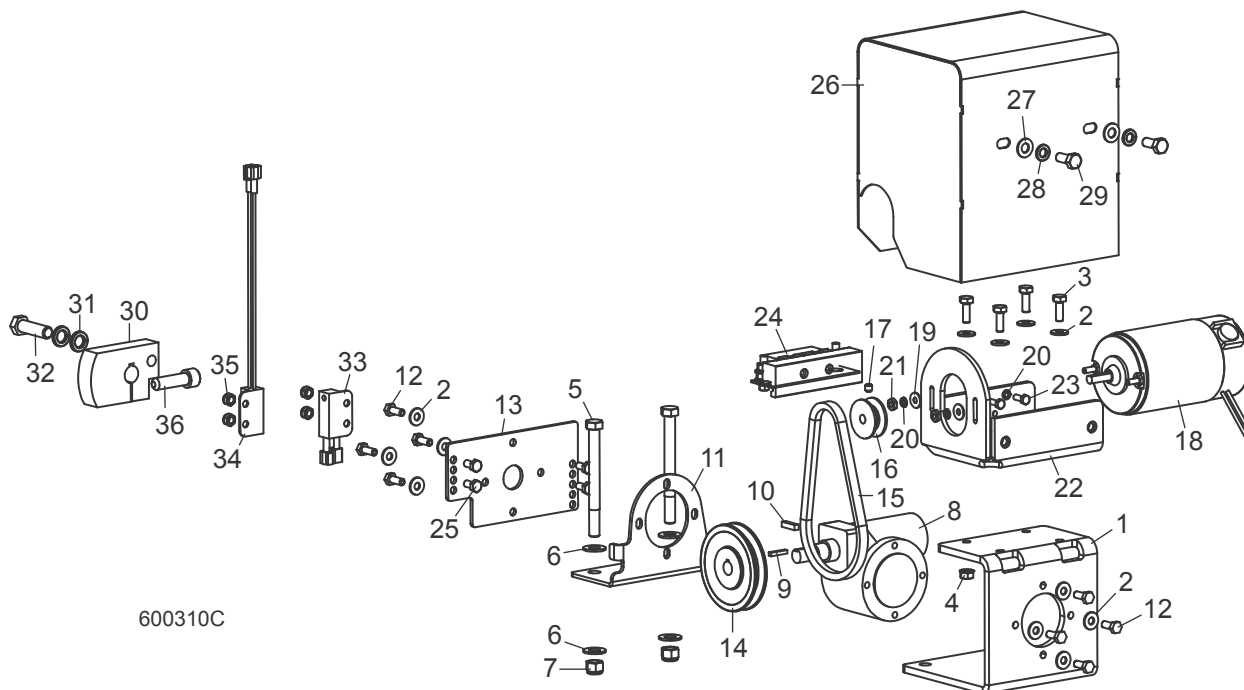

600310C

REF	DESCRIPTION (◆ Indicates Parts Available In Assemblies Only)	PART #	QTY.
	AUTOCLUTCH ASSEMBLY, LT70 2010	008953	1
1	Bracket, Autoclutch Front Mount	008949	1
2	Washer, 1/4" SAE Flat	F05011-11	12
3	Bolt, 1/4-20 x 3/4" Hex Head Grade 5	F05005-123	4
4	Nut, 1/4-20 Self-Locking Hex	F05010-9	4
5	Bolt, 3/8-16 x 4" Hex Head	F05007-4	2
6	Washer, 3/8" SAE Flat	F05011-3	4
7	Nut, 3/8-16 Hex Nylon Lock	F05010-10	2
8	Gearbox, 61:1 512 Reducer	036764	1
9	Key, 1/8" Sq. x 3/4" Long	036803	1
10	Key, 3/16" Sq. x 3/4" Long	S03060	1
11	Bracket, Autoclutch Rear Mount	008952	1
12	Bolt, M6 x 1 x 16mm Hex Head	F05004-219	8
13	Plate, Sensor Mount	013982	1
14	Pulley, OK30 x 1/2" Special	015075	1
15	Belt, 3L140	016219	1
16	Pulley, 1.42" x .32" Motor	015074	1
17	Screw, 1/4-28 x 1/4" Socket Head Cup Point Set	F05005-105	1
18	Motor Assembly, Autoclutch Replacement	016021	1
	Brush Kit, Leeson Motor External	034002	1

19	Washer, #10 SAE Flat	F05011-18	2	
20	Washer, #10 Split Lock	F05011-20	4	
21	Nut, #10-32 Hex	F05010-27	2	
22	Bracket Weldment, Autoclutch Motor Mount	034670	1	
23	Bolt, #10-24 x 1/2" Hex Head	F05004-27	2	
	Module Kit, Autoclutch Upgrade	052791	1	
24	Module Assembly, Mosfet 4X Autoclutch	024618	1	◆
	Capacitor Assembly, 1000uF with 1/4" Ring Terminals	024163	1	
	Diode Assembly, Autoclutch Gate	061052	1	
	Tie Wrap, 3/16" x 6" Black UV	F05089-3	1	
	Instruction Sheet, Autoclutch Mosfet Installation	052791-1260	1	
25	Bolt, M6 x 12 Hex Head Full Thread Grade 8-8	F05005-99	4	
26	Guard Weldment, Autoclutch	034667	1	
27	Washer, 5/16" SAE Flat	F05011-17	2	
28	Washer, 5/16" Split Lock	F05011-13	2	
29	Bolt, 5/16-18 x 3/4" Hex Head	F05006-5	2	
30	Cam, Autoclutch	034675	1	
31	Washer, 7/16" Split Lock	F05011-48	2	
32	Bolt, 7/16-20 x 1 1/2" Hex Head Grade 5	F05007-156	1	
33	Sensor Assembly, AutoClutch Engage	051337	1	
34	Sensor Assembly, Proximity Magnetic	024627	1	
35	Nut, M6-1.0 Hex Nylon Lock	F05010-200	4	
36	Bolt, 7/16-20 x 1 1/2" Socket Head	F05007-55	1	

4 Saw Head

Autoclutch Assembly (DC Only)

4.5 Autoclutch Assembly (DC Only)

LT70HD

Rev. B3.02

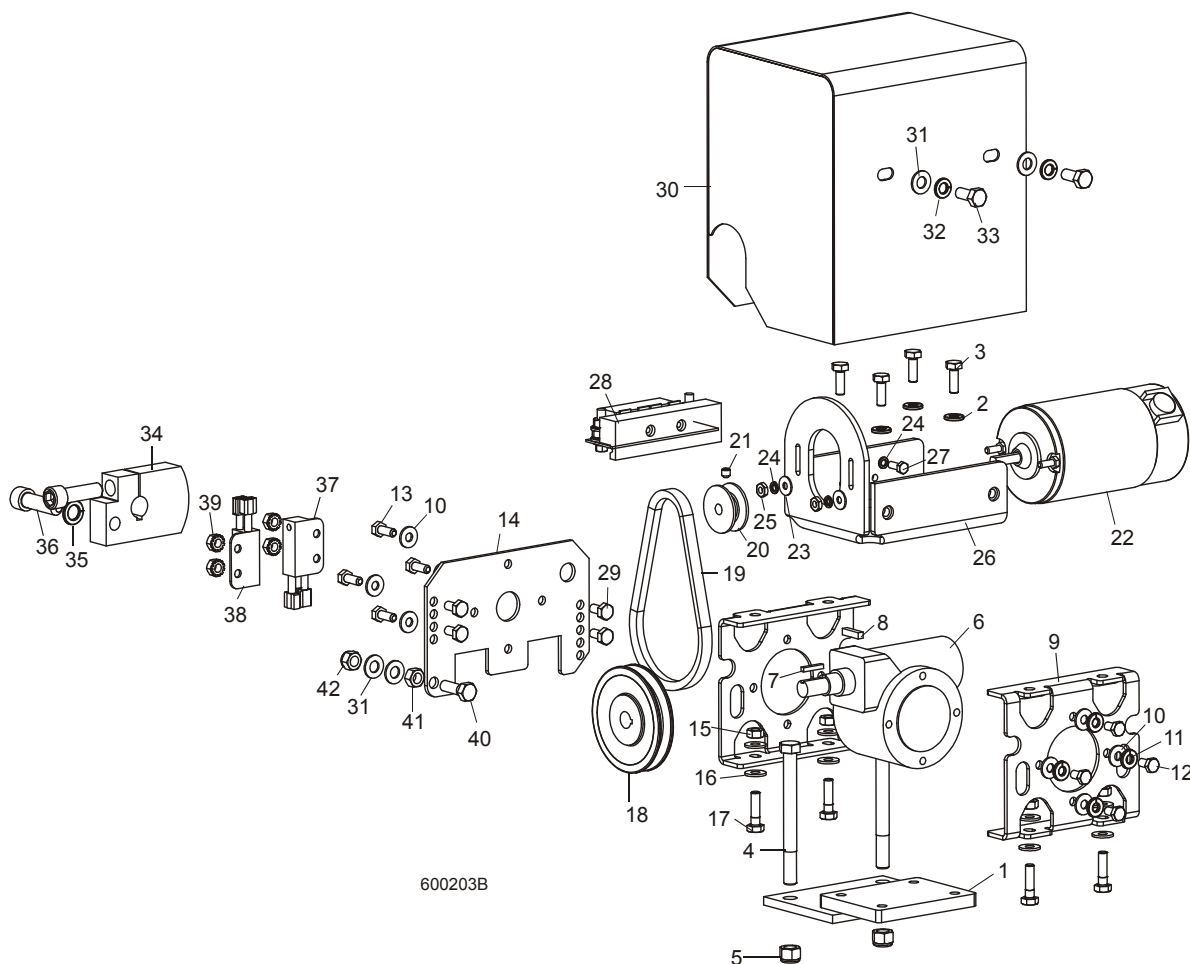

REF	DESCRIPTION (◆ Indicates Parts Available In Assemblies Only)	PART #	QTY.
	AUTOCLUTCH ASSEMBLY, LT60/70	034692	1
1	Plate Weldment, Autoclutch Mount	034678	1
2	Washer, 1/4" Split Lock	F05011-14	4
3	Bolt, 1/4-20 x 3/4" Hex Head Grade 5	F05005-123	4
4	Bolt, 3/8-16 x 4" Hex Head	F05007-4	2
5	Nut, 3/8-16 Hex Nylon Lock	F05010-10	2
	Gearbox Assy, LT60/70 Autoclutch	036787	1
6	Gearbox, 61:1 512 Reducer	036764	1
7	Key, 1/8" Sq. x 3/4" Long	036803	1
8	Key, 3/16" Sq. x 3/4" Long	S03060	1
9	Mount Weldment, Autoclutch Gearbox LT60/70	036794	2
10	Washer, 1/4" SAE Flat	F05011-11	8

11	Washer, 1/4" Split Lock	F05011-14	4	
12	Bolt, M6 x 12 Full Thread Grade 8.8 Hex Head	F05005-99	4	
13	Bolt, M6 x 1 x 16mm Hex Head	F05004-219	4	
14	Plate, Sensor Mount	036785	1	
15	Nut, 1/4-20 Hex Lock	F05010-21	4	
16	Washer, 1/4" SAE Flat	F05011-11	8	
17	Bolt, 1/4-20 x 1" Hex Head Grade 5	F05005-101	4	
18	Pulley, OK30 x 1/2" Special	015075	1	
19	Belt, 3L140	016219	1	
20	Pulley, 1.42" x .32" Motor	015074	1	
21	Screw, 1/4-28 x 1/4" Socket Head Cup Point Set	F05005-105	1	
22	Motor Assembly, Autoclutch Replacement	016021	1	
	Brush Kit, Leeson Motor External	034002	1	
23	Washer, #10 SAE Flat	F05011-18	2	
24	Washer, #10 Split Lock	F05011-20	4	
25	Nut, #10-32 Hex	F05010-27	2	
26	Bracket Weldment, Autoclutch Motor Mount	034670	1	
27	Bolt, #10-24 x 1/2" Hex Head	F05004-27	2	
	Module Kit, Autoclutch Upgrade	052791	1	
28	Module Assembly, Mosfet 4X Autoclutch	024618	1	◆
	Capacitor Assembly, 1000uF with 1/4" Ring Terminals	024163	1	
	Diode Assembly, Autoclutch Gate	061052	1	
	Tie Wrap, 3/16" x 6" Black UV	F05089-3	1	
	Instruction Sheet, Autoclutch Mosfet Installation	052791-1260	1	
29	Bolt, 1/4-20 x 1/2" Hex Head	F05005-15	4	
30	Guard Weldment, Autoclutch	034667	1	
31	Washer, 5/16" SAE Flat	F05011-17	4	
32	Washer, 5/16" Split Lock	F05011-13	2	
33	Bolt, 5/16-18 x 3/4" Hex Head	F05006-5	2	
34	Cam, Autoclutch	034675	1	
35	Washer, 7/16" Split Lock	F05011-48	1	
36	Bolt, 7/16-20 x 1 1/2" Socket Head	F05007-55	2	
37	Sensor Assembly, AutoClutch Engage	051337	1	
38	Sensor Assembly, Proximity Magnetic	024627	1	
39	Nut, 1/4-20 Hex Self-Locking	F05010-9	4	
40	Bolt, 5/16-18 x 1" Hex Head	F05006-1	1	
41	Nut, 5/16-18 Hex	F05010-17	1	
42	Nut, 5/16-18 Hex Nylon Lock	F05010-58	1	

4 Saw Head

Board Return Assembly

4.6 Board Return Assembly

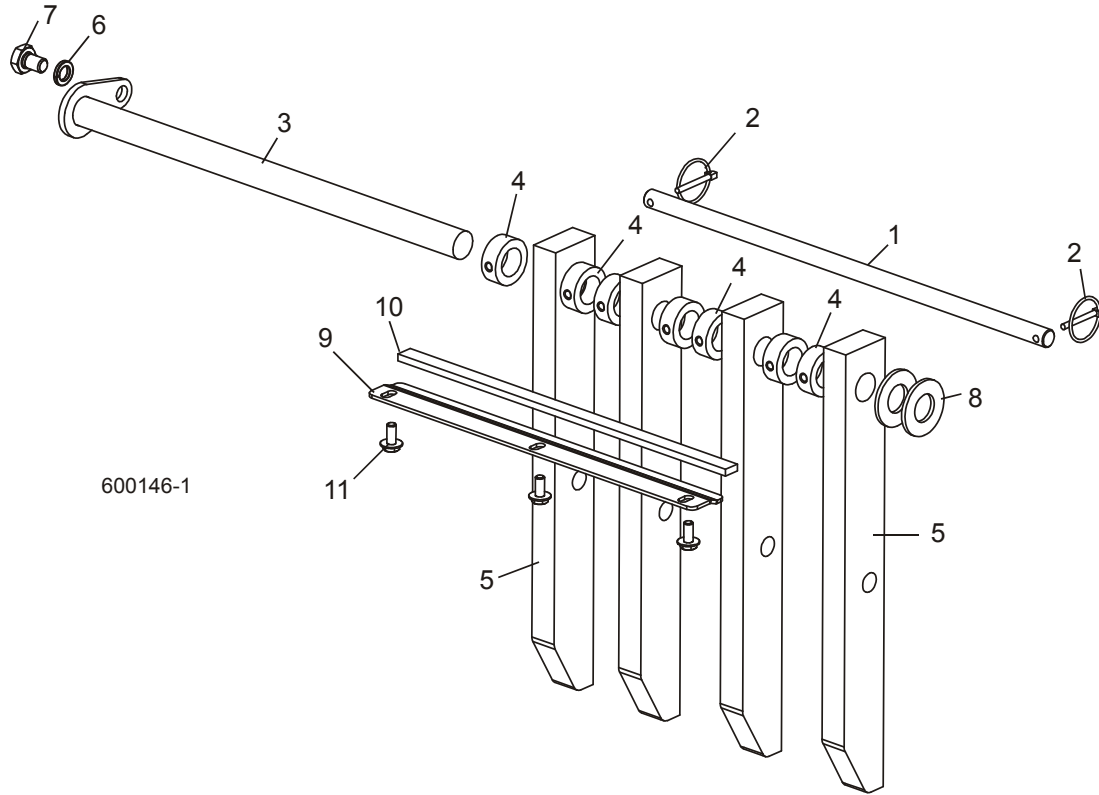

REF	DESCRIPTION (◆ Indicates Parts Available In Assemblies Only)	PART #	QTY.
1	PIN, BOARD RETURN LOCK	034565	1
2	PIN, 3/16" W/CHAIN	017604	2
3	PIN WELDMENT, BOARD RETURN MOUNT	034567	1
4	COLLAR, 1" LOCK	038090	7
5	ARM, BOARD RETURN W/STOP	034561	4
6	WASHER, 1/2" SPLIT LOCK	F05011-9	1
7	BOLT, 1/2-13 X 3/4" HEX HEAD GRADE 5	F05008-101	1
8	WASHER, 1" SAE	F05011-28	2
9	BRACKET, BOARD RETURN BUMPER	017856	1
10	BUMPER, BOARD RETURN	017857	1
11	BOLT, 5/16-18 X 3/4" HEX WASHER HEAD	F05006-101	3

4.7 Water Lube Assembly

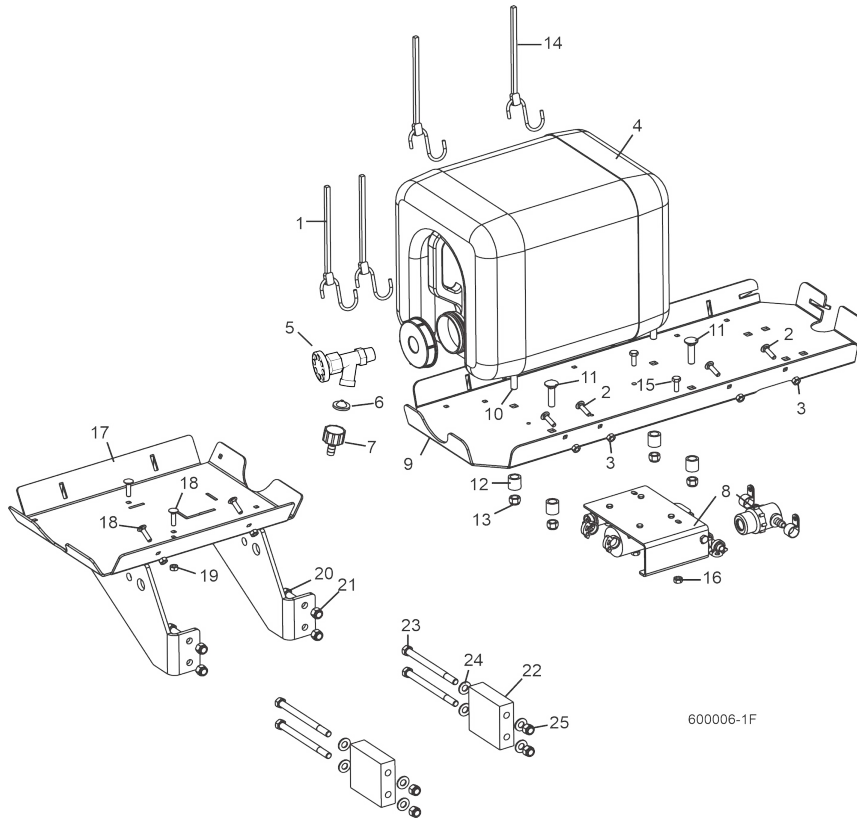

REF	PART #	DESCRIPTION	COMMENTS	QTY.
1	P11668	STRAP, 20" RUBBER		2
2	F05005-34	BOLT, 1/4-20 X 1" CARRIAGE HEAD		4
3	F05010-21	NUT, 1/4-20 HEX LOCK		4
4	014642	BOTTLE ASSEMBLY, WATER LUBE W/CAP		1
	061372	O-ring, Water Bottle Cap	If the water bottle cap keeps leaking, add this o-ring to the cap. Leave the existing o-ring installed.	1
	014636	FITTING, 3/4FPT X 3/4MPT	Removed after 9/19/2024 per ECN 38718.	1
5	133320	VALVE, 3/4 NPT ELBOW 3/4 MALE GHT OUTLET	Replaced 014100 after 9/19/2024 per ECN 38718.	1
	014100	FITTING, WATER LUBE SHUTOFF VALVE		1
6	016086	FILTER, WATER LUBE		1
7	014113	FITTING, 5/8" NPT TO 3/8" HOSE BARB		1
8		LUBEMIZER PARTS/HOSES (SEE LUBEMIZER OPTION MANUAL)		
9	S11684	TRAY, WATER LUBE/FUEL TANK MOUNT (GAS/DIESEL ONLY)	See Engine Option manual for fuel tank parts.	1
10	F05007-22	BOLT, 3/8-16 X 2" CARRIAGE HEAD FULL THREAD		1
11	F05007-85	BOLT, 3/8-16 X 1 1/2" CARRIAGE HEAD GRADE 5		3

4

Saw Head*Water Lube Assembly*

REF	PART #	DESCRIPTION	COMMENTS	QTY.
12	033911	SPACER, TANK TRAY		4
13	F05010-10	NUT, 3/8-16 HEX NYLON LOCK		4
14	P11258	STRAP, 24" RUBBER (GAS/DIESEL ONLY)		2
15	F05005-1	BOLT, 1/4-20 X 3/4" HEX HEAD FULL THREAD		2
16	F05010-9	NUT, 1/4-20 HEX SELF-LOCKING		2
17	034491	TRAY WELDMENT, WATER LUBE MOUNT (E25/E30 ONLY)		1
18	F05005-34	BOLT, 1/4-20 X 1" CARRIAGE HEAD		4
19	F05010-21	NUT, 1/4-20 HEX LOCK		4
20	F05007-7	BOLT, 3/8-16 X 1" HEX HEAD		4
21	F05010-10	NUT, 3/8-16 HEX NYLON LOCK		4
22	007660	SPACER, E30 WATERLUBE (E30 ONLY)		2
23	F05007-5	BOLT, 3/8-16 X 5" HEX HEAD		4
24	F05011-3	WASHER, 3/8" SAE FLAT		8
25	F05010-10	NUT, 3/8-16 HEX NYLON LOCK		4
	CBOTTLE	COVER, 5 GAL. WATER BOTTLE OPTIONAL (NOT SHOWN)		1

4.8 Saw Head Decals

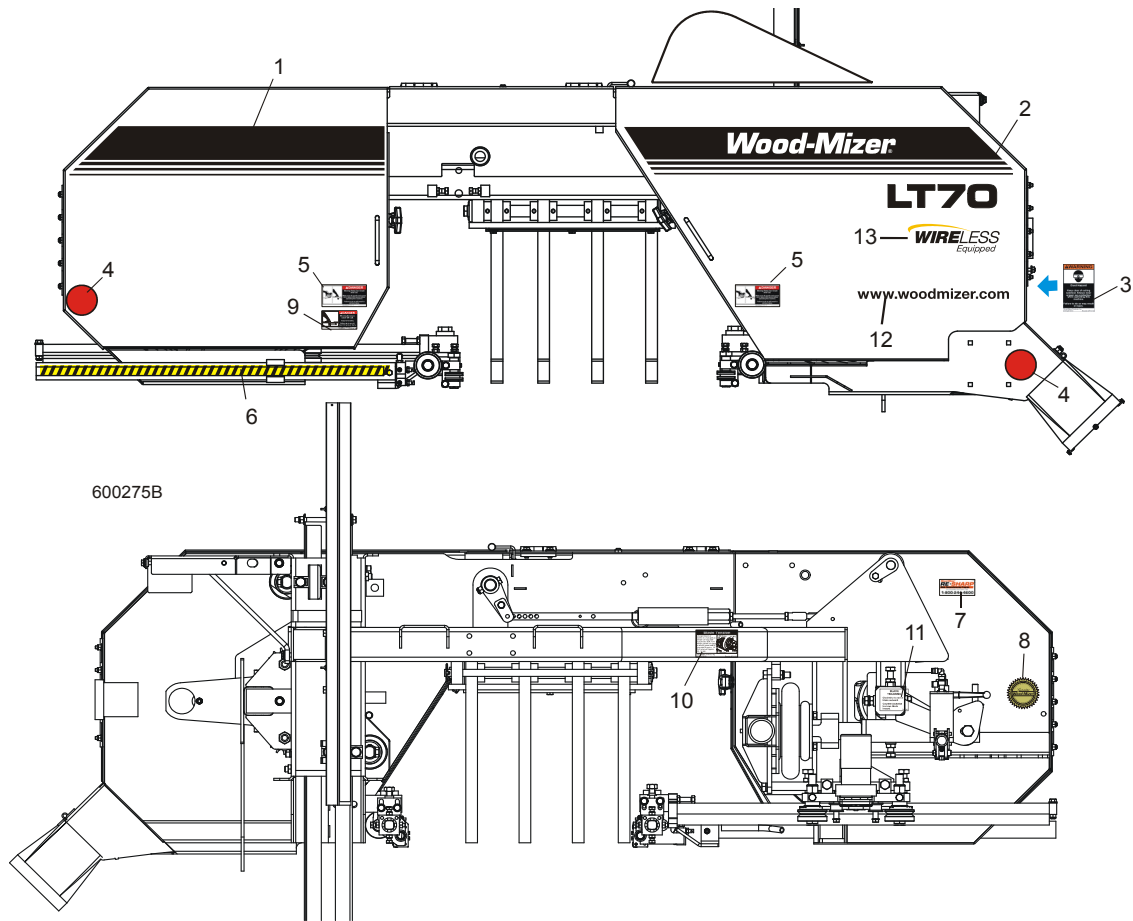

REF	DESCRIPTION (◆ Indicates Parts Available In Assemblies Only)	PART #	QTY.
1	DECAL, IDLE SIDE BLADE COVER	003249	1
2	DECAL, LT70 LOGO W/STRIPES	003248	1
3	DECAL, SAWDUST CHUTE WARNING	P11754	1
4	DECAL, RED REFLECTIVE 2" ROUND	P07452	2
5	DECAL, BLADE COVERS DANGER	033254	2
6	DECAL, BLADE GUIDE ARM STRIPE	015849	1
7	DECAL, BLADE RESHARP INFO	P12879	1
8	DECAL, WOOD-MIZER QUALITY	015930	1
9	DECAL, BLADE DANGER	S11752	1
10	DECAL, LT60/70 BLADE TENSION INFO	038596	1
11	DECAL, BLADE ALIGNMENT	P11789	1
12	DECAL, WOOD-MIZER WEBSITE	003235	1
13	DECAL, WIRELESS EQUIPPED LOGO	057782	1

4 Saw Head

Blade Housing Covers

4.9 Blade Housing Covers

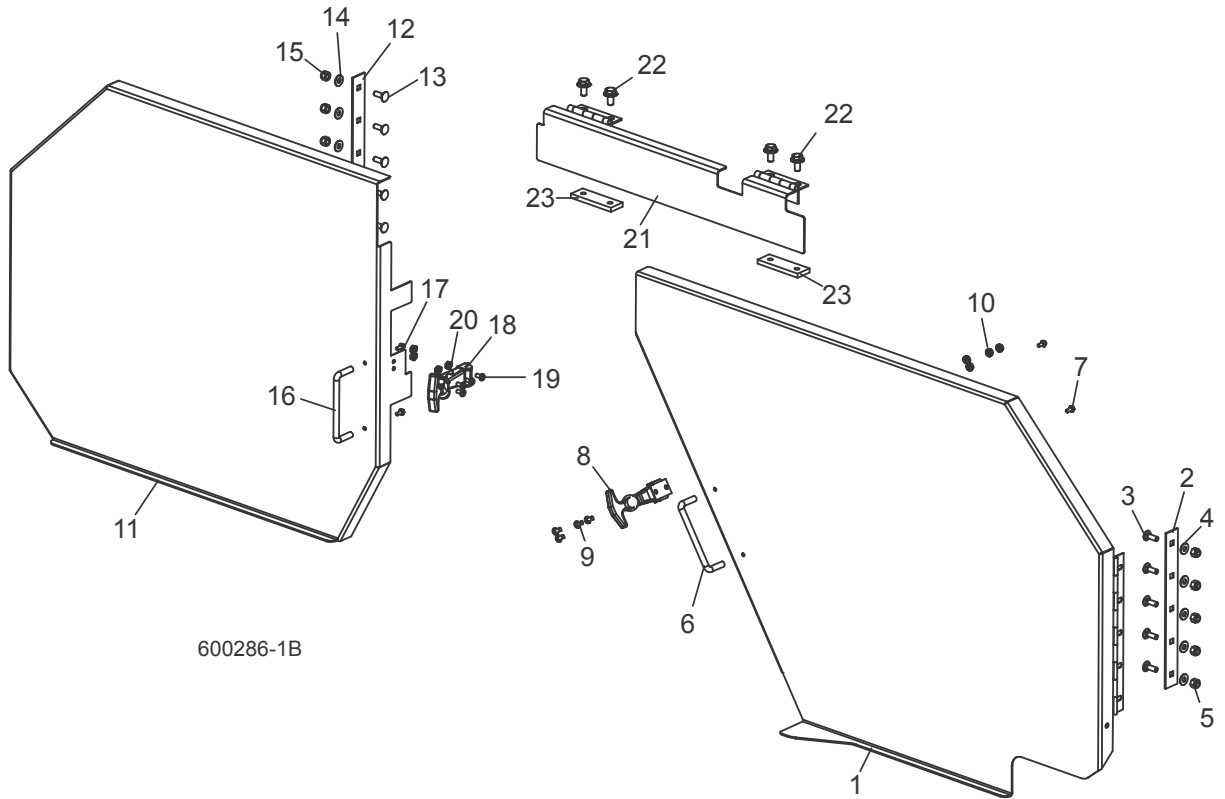

600286-1B

REF	DESCRIPTION (◆ Indicates Parts Available In Assemblies Only)	PART #	QTY.
	COVER ASSEMBLY, DRIVE SIDE BLADE HOUSING	048409	1
1	Cover Weldment, Drive Side Blade Housing	048403	1
2	Plate, Hinge Backing	034251	1
3	Bolt, 1/4-20 x 3/4" Carriage Head	F05005-113	5
4	Washer, 1/4" SAE Flat	F05011-11	5
5	Nut, 1/4-20 Hex Nylon Lock	F05010-69	5
6	Handle, Blade Housing Cover	P08065	1
7	Screw, #8-32 x 3/8" Self-Tapping	F05015-8	2
8	Latch, Flexible Draw	014829	1
9	Screw, #10-24 x 3/8" Cross Slotted Pan Head	F05004-3	4
10	Nut, #10-24 Hex Self-Locking	F05010-14	4
	COVER ASSEMBLY, IDLE SIDE BLADE HOUSING	036178	1
11	Cover Weldment, Idle Side Blade Housing	036176	1
12	Plate, Hinge Backing	034251	1
13	Bolt, 1/4-20 x 3/4" Carriage Head	F05005-113	5
14	Washer, 1/4" SAE Flat	F05011-11	5
15	Nut, 1/4-20 Hex Nylon Lock	F05010-69	5
16	Handle, Blade Housing Cover	P08065	1

17	Screw, #8-32 x 3/8" Self-Tapping	F05015-8	2	
18	Latch, Flexible Draw	014829	1	
19	Screw, #10-24 x 3/8" Cross Slotted Pan Head	F05004-3	4	
20	Nut, #10-24 Hex Self-Locking	F05010-14	4	
21	COVER WELDMENT, MIDDLE BLADE HOUSING	034454	1	
	COVER WELDMENT, MIDDLE BLADE HOUSING (WIDE HEAD ONLY)	006189	1	
22	BOLT, 5/16-18 X 3/4" HEX HEAD W/FLAT & LOCK WASHER	F05006-101	4	
23	NUT PLATE, MIDDLE COVER	006810	2	

4 Saw Head
Sawdust Chute

4.10 Sawdust Chute

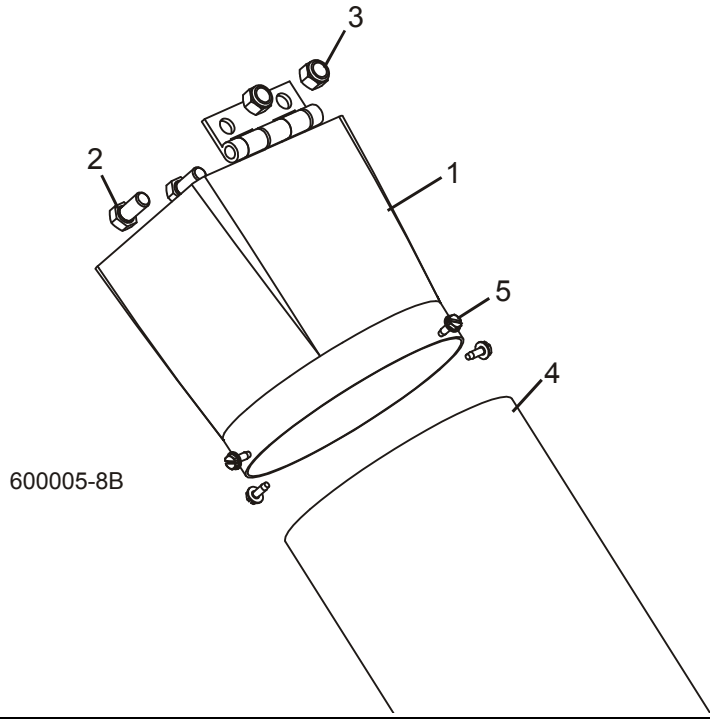

REF	DESCRIPTION (◆ Indicates Parts Available In Assemblies Only)	PART #	QTY.	
1	CHUTE WELDMENT, SAWDUST	034396	1	
2	BOLT, 3/8-16 X 3/4" HEX HEAD GRADE 5	F05007-118	2	
3	NUT, 3/8-16 HEX NYLON LOCK	F05010-10	2	
4	TUBING, RUBBER SAWDUST	017829	2	
5	BOLT, #10-24 X 1/2" SELF-TAPPING	F05015-7	4	

4.11 Debarker Wire Box/Grommet

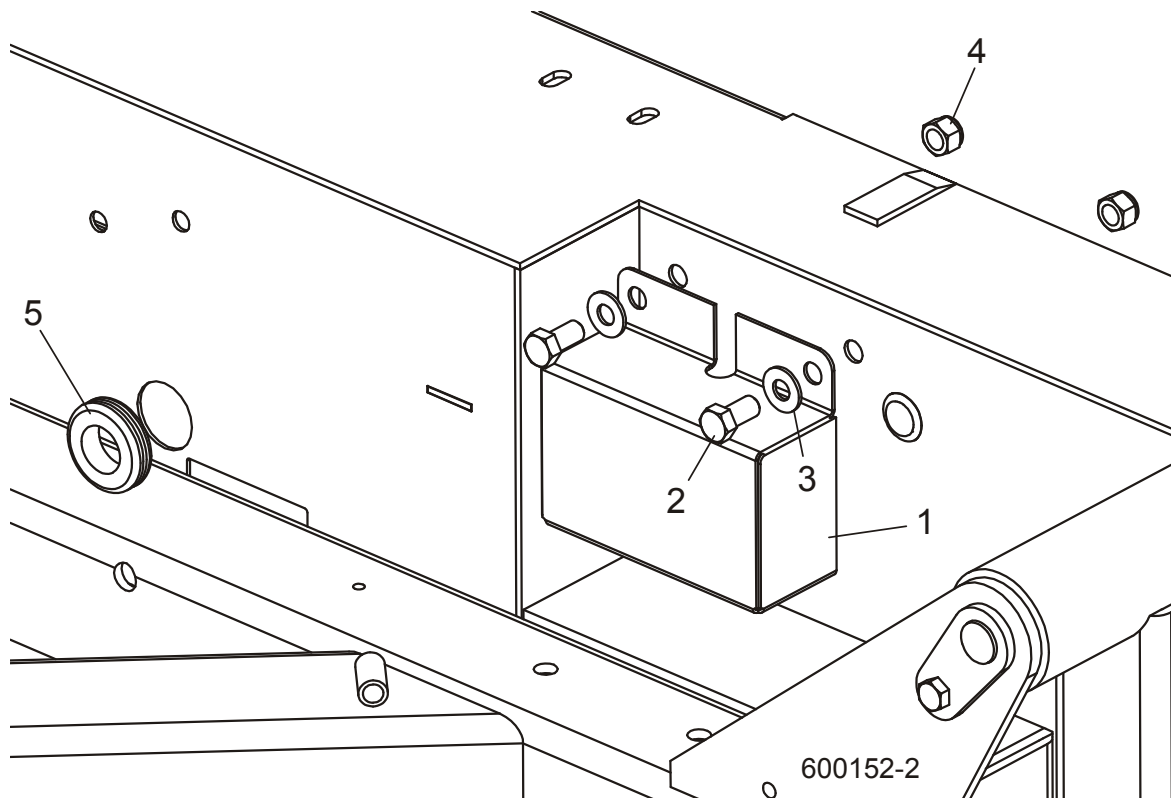

REF	DESCRIPTION (◆ Indicates Parts Available In Assemblies Only)	PART #	QTY.
1	BOX, DEBARKER WIRE STORAGE	023616	1
2	BOLT, 3/8-16 X 3/4" HEX HEAD	F05007-7	2
3	WASHER, 3/8" SAE FLAT	F05011-3	2
4	NUT, 3/8-16 HEX NYLON LOCK	F05010-10	2
5	GROMMET, 7/8" ID X 1 1/4" GROOVED OD	P702	1

5 Engine Options

SECTION 5 ENGINE OPTIONS

LT70HD

REF	DESCRIPTION	MASTER	Elec. Info	
	D51 CATERPILLAR ENGINE OPTION (SEE ENGINE OPTION MANUAL)	M1146	M1141	
	D55 YANMAR ENGINE OPTION (SEE ENGINE OPTION MANUAL)	M1589	M1590	
	D62 CATERPILLAR ENGINE OPTION (SEE ENGINE OPTION MANUAL)	M1138	M1141	
	E25 LINCOLN ENGINE OPTION (SEE ENGINE OPTION MANUAL)	M1083	M1092 C M1088 H M1090 L	
	E30 ENGINE OPTION (SEE ENGINE OPTION MANUAL)	M1778	M1779	

LT70HD Wireless

REF	DESCRIPTION	MASTER	Elec. Info	
	D51 CATERPILLAR ENGINE OPTION (SEE ENGINE OPTION MANUAL)	M1146	M1556	
	D55 YANMAR ENGINE OPTION (SEE ENGINE OPTION MANUAL)	M1589	M1592	
	D62 CATERPILLAR ENGINE OPTION (SEE ENGINE OPTION MANUAL)	M1138	M1556	
	E25 LINCOLN ENGINE OPTION (SEE ENGINE OPTION MANUAL)	M1083	M1557 C M1558 H M1559 L	
	E30 ENGINE OPTION (SEE ENGINE OPTION MANUAL)	M1778	M1780	

SECTION 6 OPTIONS & ADDITIONAL INCLUDED EQUIPMENT

LT70HD/LT70HD Wireless

REF	DESCRIPTION (◆ Indicates Parts Available In Assemblies Only)	MASTER	
INCLUDED EQUIPMENT			
	ACCUSET 2 (SEE MANUAL)	M1521	
	MKII DEBARKER (AC) (SEE MANUAL)	M1106	
	MKII DEBARKER (DC) (SEE MANUAL)	M1060	
	FINE ADJUST OUTRIGGERS (2008) (SEE MANUAL)	M1524	
	LUBEMIZER (SEE MANUAL)	M930	
AVAILABLE OPTIONS			
	BED EXTENSION (SEE MANUAL)	M530	
	LASER SIGHT (SEE MANUAL)	M1081	
	OPERATOR'S SEAT (SEE MANUAL)	M859	

7 Debarker

Debarker Assembly (DC Complete)

SECTION 7 DEBARKER

7.1 Debarker Assembly (DC Complete)

MKIII LT70 A.00+

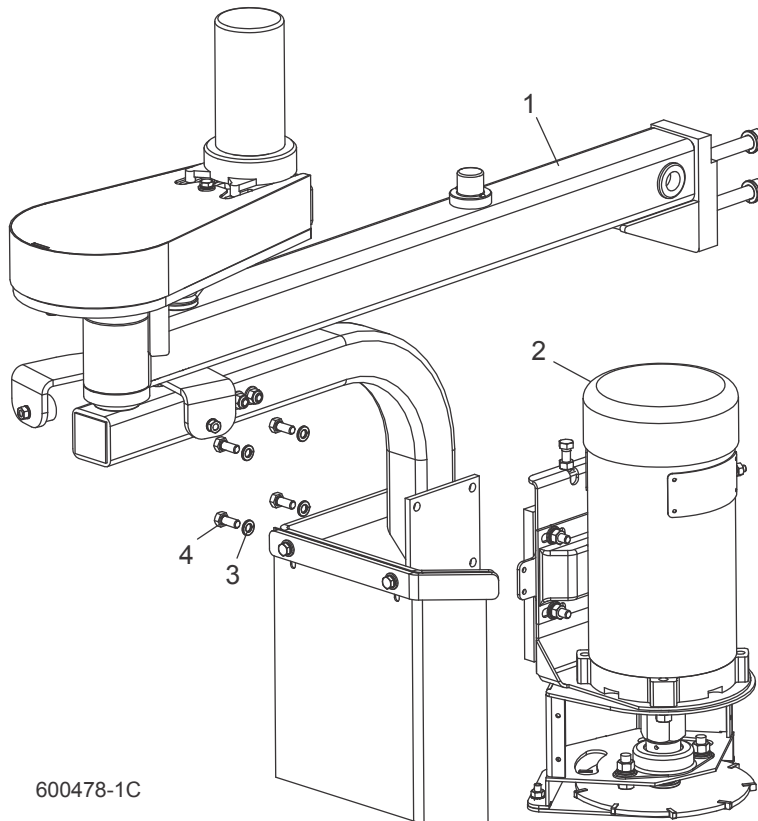

REF	DESCRIPTION (◆ Indicates Parts Available In Assemblies Only)	PART #	QTY.
	DEBARKER ASSEMBLY, LT70 MECHANICAL	076678	1
1	Frame Parts (See Section 7.5)		
2	Cutter Head Parts (See Section 7.9)		
3	Washer, 5/16" Split Lock	F05011-13	4
4	Bolt, 5/16-18 x 3/4" Hex Head	F05006-5	4
	Plate, LT70 Wide Debarker Pivot Stop	076683	1
	Cover, 3/4HP Leeson Motor	015761	1

7.2 Debarker Assembly (DC Complete)

MKII LT70 A.00 - B.03

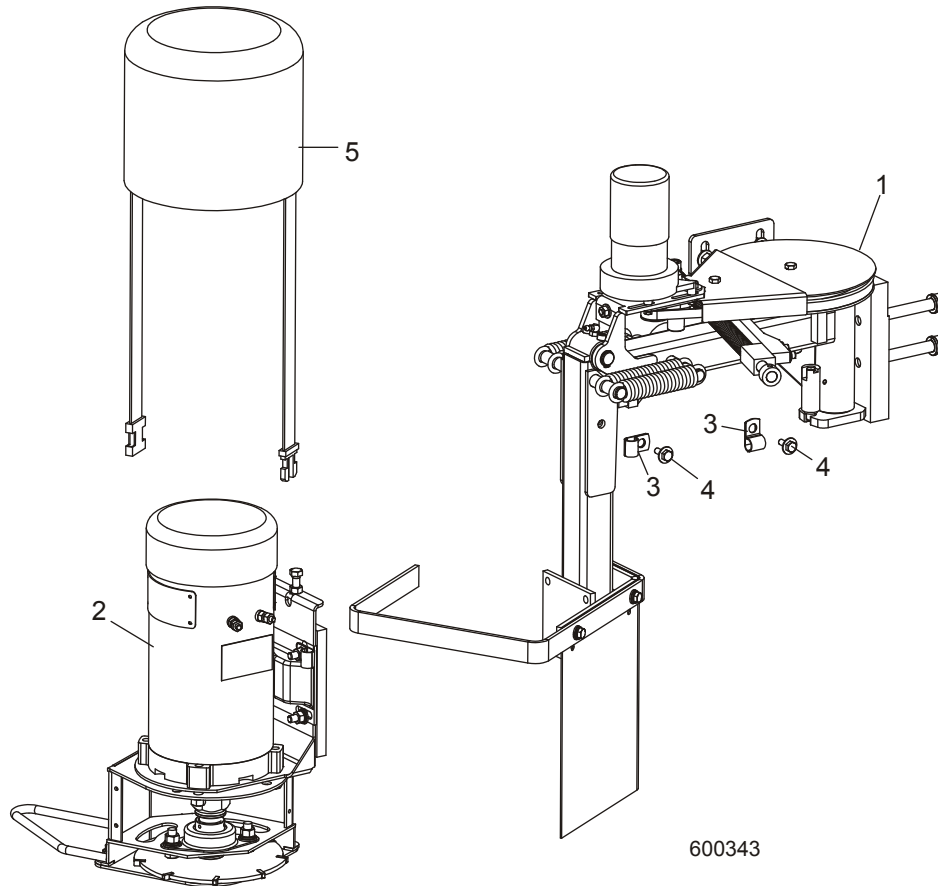

REF	DESCRIPTION (◆ Indicates Parts Available In Assemblies Only)	PART #	QTY.
	DEBARKER ASSEMBLY, DC LT70	025902	1
1	Frame Parts (See Section 7.6)		
2	DC Cutter Head Parts (See Section 7.10)		
	AC Cutter Head Parts (See Section 7.12)		
3	Clamp, 1/2" EMT Coated	P07584	2
4	Bolt, 1/4-20 x 3/4" Hex Head w/Conical Washer Head	F05005-134	2
5	Cover, 3/4HP Leeson Motor (DC Only)	015761	1

7 Debarker

Debarker Assembly (AC Complete)

7.3 Debarker Assembly (AC Complete)

MKIII LT70 A.00+

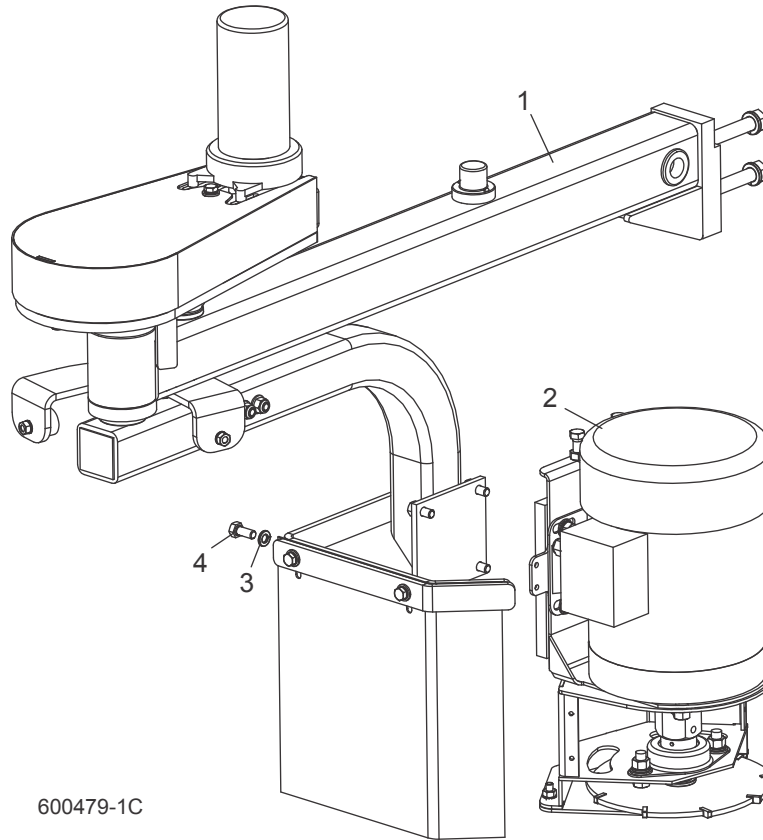

REF	DESCRIPTION (◆ Indicates Parts Available In Assemblies Only)	PART #	QTY.
	MECHANICAL ASSEMBLY, LT60HD/70HD AC DEBARKER (BOXED)	074883	1
	Debarker Assembly, LT70 AC Mechanical	074860	1
1	Frame Parts (See Section 7.5)		
2	Cutter Head Parts (See Section 7.11)		
3	Washer, 5/16" Split Lock	F05011-13	4
4	Bolt, 5/16-18 x 3/4" Hex Head	F05006-5	4
	Plate, LT70 Wide Debarker Pivot Stop	076683	1
	Cover, 3/4HP Leeson Motor	015761	1

7.4 Debarker Assembly (AC Complete)

MKII LT70 A.00 - B.03

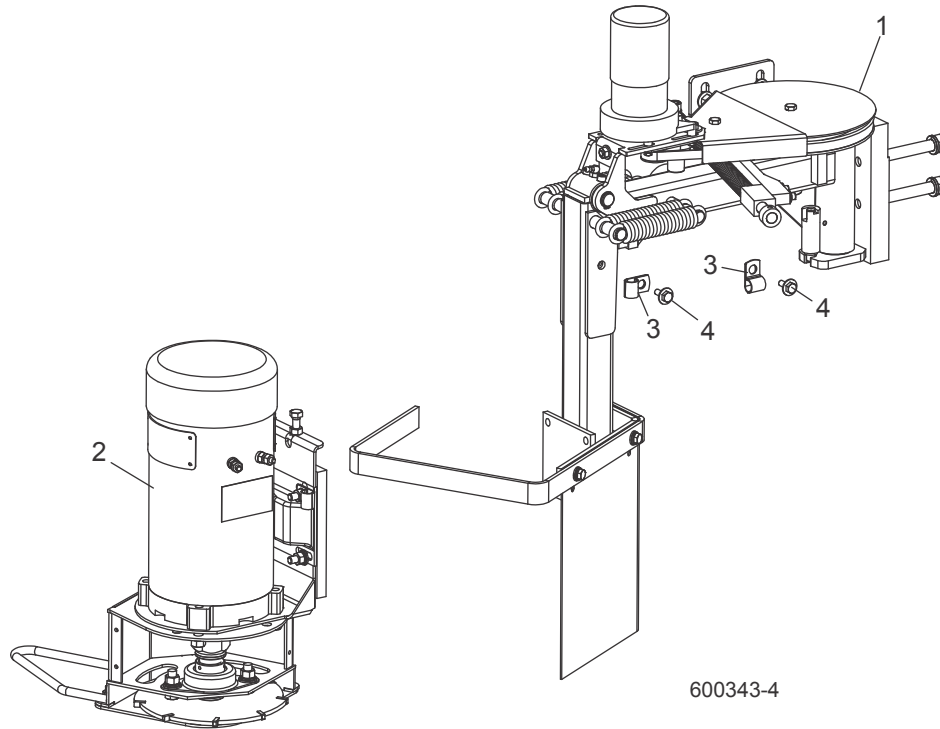

REF	DESCRIPTION (◆ Indicates Parts Available In Assemblies Only)	PART #	QTY.	
	DEBARKER ASSEMBLY, AC LT70	065517	1	
1	Frame Parts (See Section 7.6)			
2	DC Cutter Head Parts (See Section 7.10)			
	AC Cutter Head Parts (See Section 7.12)			
3	Clamp, 1/2" EMT Coated	P07584	2	
4	Bolt, 1/4-20 x 3/4" Hex Head w/Conical Washer Head	F05005-134	2	

7.5 Frame Assembly

MKIII LT70 A.00+

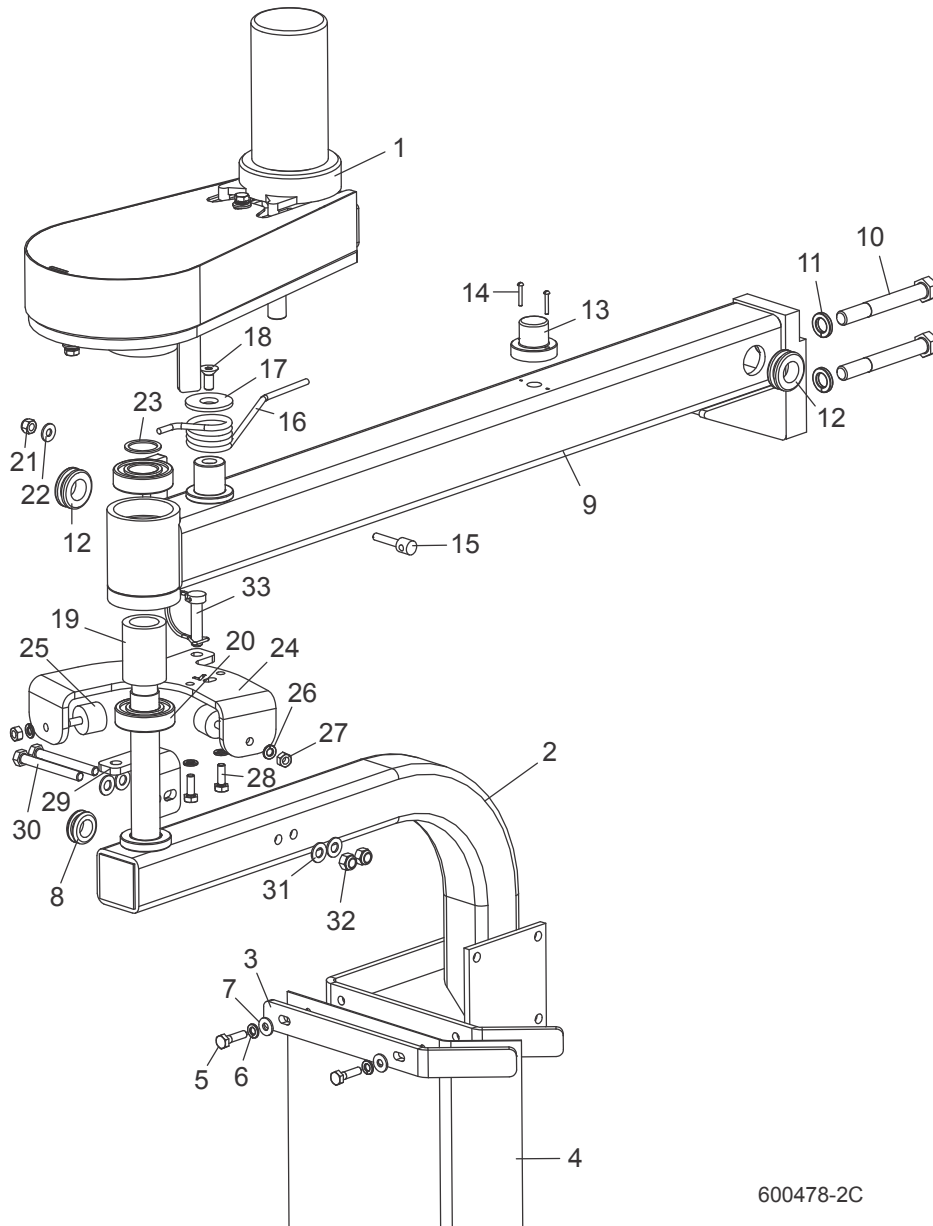

600478-2C

REF	DESCRIPTION (◆ Indicates Parts Available In Assemblies Only)	PART #	QTY.	
1	DEBARKER IN/OUT MOTOR PARTS (See Section 7.7)			
	PIVOT ARM ASSEMBLY, LT70 DC DEBARKER (LT70 SUPER HD ONLY)	074824	1	
	PIVOT ARM ASSEMBLY, LT70 AC DEBARKER (LT70 DCS ONLY)	074859	1	
2	Arm Weldment, LT70 Debarker Pivot	076675	1	
3	Plate, Debarker Flex Guard Retaining	076749	1	

4	Guard, Debarker Flex	021232	1	
5	Bolt, 1/4-20 x 1" Hex Head	F05005-38	2	
6	Washer, 1/4" Split Lock	F05011-14	2	
7	Washer, 1/4" SAE Flat	F05011-11	2	
8	Grommet, 5/8" ID 3/16" GW Rubber	033475	1	
	DC Cutter Head Parts (LT70 Super HD Only)			
	AC Cutter Head Parts (LT70 DCS Only)			
	MOUNT ARM ASSEMBLY, LT70 DEBARKER	074823	1	
9	Mount Arm Weldment, LT70 Debarker	076676	1	
10	Bolt, 1/2-13 x 4" Hex Head Grade 5	F05008-78	2	
11	Washer, 1/2" Split Lock	F05011-9	2	
12	Grommet, Rubber 3/4 ID	025247	2	
13	Lamp Assembly, 180 Degree Amber Strobe	073555	1	
14	Bolt, 4-40 x 3/4 SI	F05004-13	2	
15	Bushing, Debarker Spring Retaining	076139	1	
16	Spring, Debarker Tension	098605	1	
17	Washer, LT35 Torsion Spring	076039	1	
18	Bolt, 5/16-18 x 3/4" FHS	F05006-95	1	
19	Tube, Long Bearing Spacer	076739	1	
20	Bearing, SKF 6205 2RS Roller	087353	2	
21	Nut, 1/4-20 Nylock	F05010-69	1	
22	Washer, 1/4" SAE Flat	F05011-11	1	
23	SHIM, 1 ID 1-1/4" OD	076037	1	
	STOP ASSEMBLY, LT70 DEBARKER PIVOT	074878	1	
	STOP ASSEMBLY, LT70 WIDE DEBARKER PIVOT (WIDE HEAD ONLY)	074879	1	
24	Plate, LT70 Debarker Pivot Stop	076682	1	
	Plate, LT70 Wide Debarker Pivot Stop (Wide Head Only)	076683	1	
25	Bumper, 1 x 3/4" Hard Silicone Rubber	065717	2	
26	Washer, 1/4" Split Lock	F05011-14	2	
27	Nut, 1/4-20 Free	F05010-63	2	
28	Bolt, 1/4-20 x 3/4" Hex Head Grade 5	F05005-123	2	

7.6 Frame Assembly

MKII LT70 A.00 - B.03

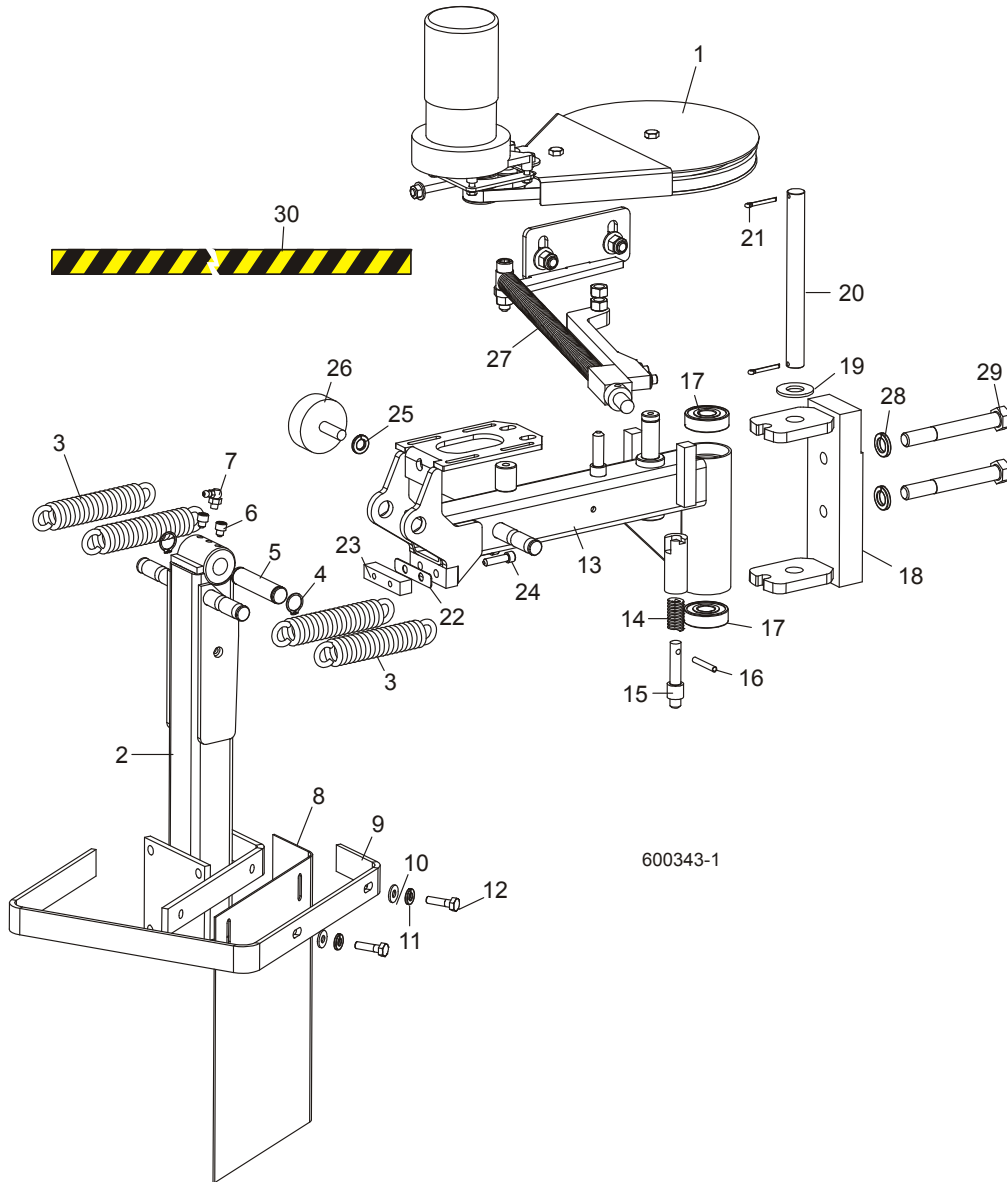

REF	DESCRIPTION (◆ Indicates Parts Available In Assemblies Only)	PART #	QTY.
	ARM ASSEMBLY, LT70 DEBARKER SWING (DCS)	025905	1
1	Debarker In/Out Motor Parts (See Section 7.8)		
2	Frame Weldment, Lower LT60 Debarker	034365	1
3	Spring, Debarker Arm	021185	4
4	Ring, 5/8" Outer Retaining	F04254-2	2

5	Pin, Debarker Pivot	023646	1	
6	Screw, 1/4-28 x 1/4" Socket Head	F05005-106	2	
7	Fitting, 1/4-28 90° Grease	P04108	1	
8	Guard, Debarker Flex	021232	1	
9	Guard, Debarker	021231	1	
10	Washer, 1/4" SAE Flat	F05011-11	2	
11	Washer, 1/4" Split Lock	F05011-14	2	
12	Bolt, 1/4-20 x 1" Hex Head	F05005-38	2	
	Frame Assembly, LT70 Debarker Upper	046031	1	
13	Frame Weldment, Debarker Upper	046032	1	
14	Spring, .58" OD x 1 1/2"	021243	1	
15	Pin, Debarker Lock	034814	1	
16	Pin, 3/16" x 1 1/4" Roll	F05012-16	1	
17	Bearing, 5/8" x 1.7548" x .4724"	P06030-1	2	
18	Mount Weldment, Debarker Pivot	046033	1	
19	Washer, 5/8" SAE Flat	F05011-5	1	
20	Pin, Debarker Pivot	046034	1	
21	Pin, 1/8" x 1" Cotter	F05012-1	2	
22	Shim, Pivot Stop	046045	1	
23	Block, Pivot Stop	046044	1	
24	Bolt, 1/4-20 x 1" Socket Head	F05005-89	2	
25	Washer, 3/8" Split Lock	F05011-4	1	
26	Bumper, Rubber	034175	1	
27	Spring Arm Parts (See Section 7.15)			
28	Washer, 1/2" Split Lock	F05011-9	2	
29	Bolt, 1/2-13 x 4" Hex Head Grade 5	F05008-78	2	
30	Decal, Bar Stripe	015849	1	

7.7 In/Out Motor Drive Assembly

MKIII LT70 A.00+

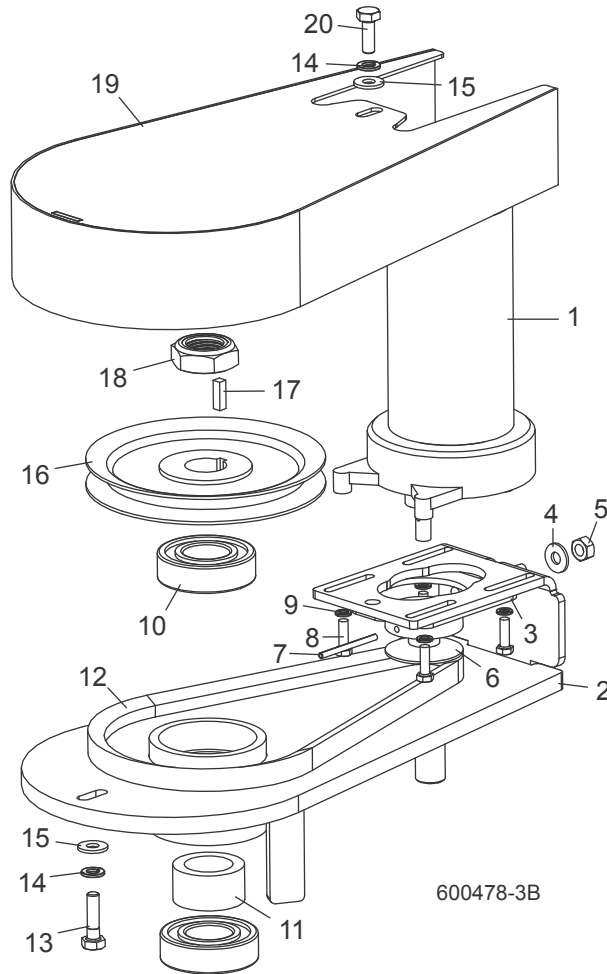

REF	DESCRIPTION (◆ Indicates Parts Available In Assemblies Only)	PART #	QTY.
	PIVOT ASSEMBLY, LT70 DEBARKER UPPER	074825	1
1	Gearmotor Assembly, LT70 Debarker In/Out	114024 ¹	1
	Boot, Gear Motor Weather	023720	1
2	Weldment, Debarker Upper Pivot	076709	1

¹ Motor 074826 replaced with 128026 in 7/19 per ECN 35985. Motor 128026 replaced with motor 114024 in 9/19 per ECN 36082.

3	Tensioner Weldment, Gear Motor	023637	1	
4	Washer, 1/4" SAE Flat	F05011-11	1	
5	Nut, 1/4-20 Swaged	F05010-21	1	
6	Sheave, LT70 Debarker Gearmotor	076666	1	
7	Pin, 1/8 x 1 5/8 Roll	F05012-102	1	
8	Screw, 10-32 x 5/8 HH Machine	F05004-152	4	
9	Washer, #10 Split Lock	F05011-20	4	
10	Bearing, SKF 6205 2RS Roller	087353	2	
11	Pin, 3/16" x 2 1/2" Roll	F05012-27	1	
12	Fitting, 3/16" x 3/16" Straight Grease	P04107	1	
13	Tube, Short Bearing Spacer	076741	1	
14	Spring, .58 OD x 1 1/8"	021243	1	
15	Pin, Transport, MKII	023650	1	
16	BELT, AX21	076689	1	
17	BOLT, 1/4-20 X 1" HEX HEAD GRADE 5	F05005-101	1	
18	WASHER, 1/4" SPLIT LOCK	F05011-14	2	
19	WASHER, 1/4" SAE FLAT	F05011-11	2	
20	PULLEY, 5X7/8 A GROOVE	076798	1	
21	KEY, 3/16" SQ X 5/8"	065214	1	
22	NUT, 7/8-14 HALF NYLOCK	F05010-238	1	
23	GUARD WELDMENT, LT70 DEBARKER BELT	076713	1	
24	BOLT, 1/4-20 X 3/4" FULL THREAD HHC	F05005-1	1	

7.8 In/Out Motor Drive Assembly

MKII LT70 A.00 - B.03

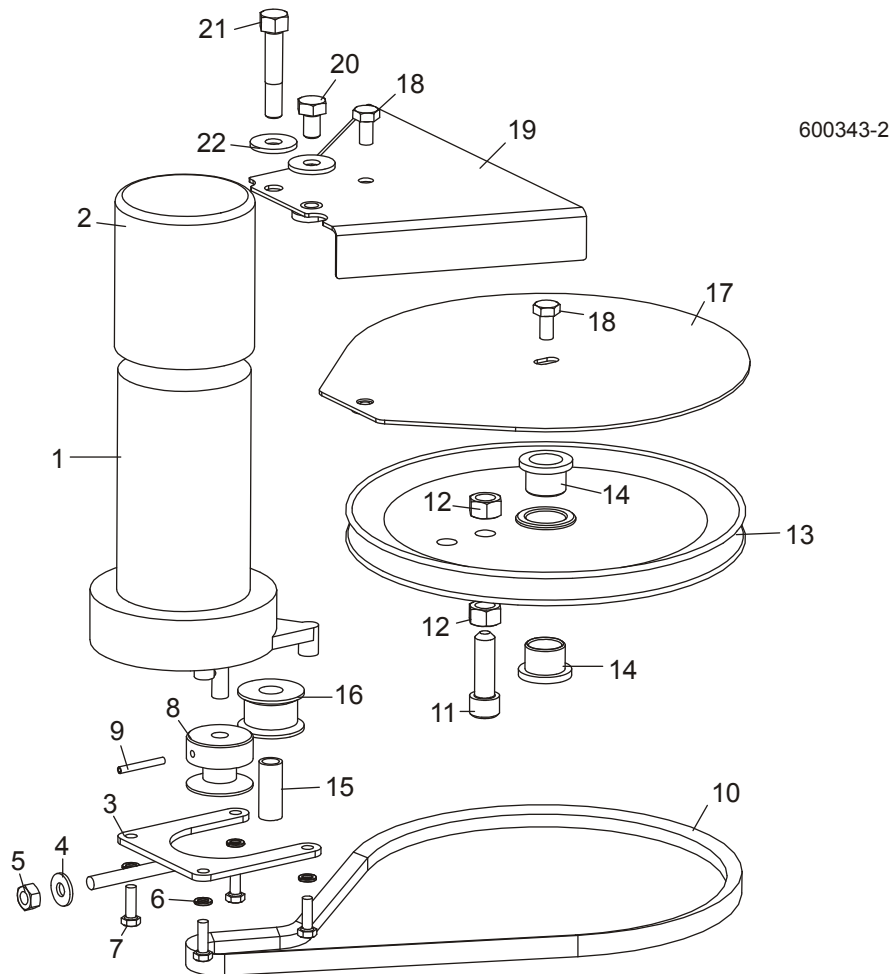

REF	DESCRIPTION (◆ Indicates Parts Available In Assemblies Only)	PART #	QTY.
1	MOTOR ASSEMBLY, DCS BLADE GUIDE DEBARKER IN/OUT	053421	1
	Housing, Klauber Motor End	P12756	1
	Gear Kit, Klauber Gear Motor Replacement	P12569	1
	Brush Kit, Gear Motor Replacement	P12800	1
	Shaft Kit, Klauber Gear Motor Replacement	009695	1
2	BOOT, GEAR MOTOR WEATHER	023720	1
3	TENSIONER WELDMENT, GEAR MOTOR	023637	1
4	WASHER, 1/4" SAE FLAT	F05011-11	1
5	NUT, 1/4-20 HEX LOCK	F05010-21	1
6	WASHER, #10 SPLIT LOCK	F05011-20	4
7	BOLT, #10-32 X 5/8" HEX HEAD	F05004-152	4
8	PULLEY, DEBARKER IN/OUT MOTOR	016181	1

9	PIN, 1/8" X 1" ROLL	F05012-34	1	
10	BELT, AX29	046039	1	
11	BOLT, 3/8-16 X 1 1/2" SOCKET HEAD	F05007-36	1	
12	NUT, 3/8-16 HEX LOCK	F05010-25	2	
13	PULLEY, DEBARKER IN/OUT DRIVE	023634	1	
14	BUSHING, FLANGED BRONZE	021203	2	
15	SPACER, .322" ID X .44 OD X 1.10" LONG	046040	1	
16	GUIDE, BELT IDLER	S09999	1	
17	GUARD WELDMENT, DEBARKER BELT	046049	1	
18	BOLT, 1/4-20 X 1/2" HEX HEAD	F05005-15	2	
19	GUARD WELDMENT, DEBARKER PULLEY	046050	1	
20	BOLT, 5/16-18 X 1/2" HEX HEAD GRADE 5	F05006-15	1	
21	BOLT, 5/16-18 X 1 3/4" HEX HEAD	F05009-70	1	
22	WASHER, 5/16" STANDARD FLAT	F05011-16	2	



Debarker
Cutter Head Assembly (DC)

7.9 Cutter Head Assembly (DC)

MKIII LT70 A.00+

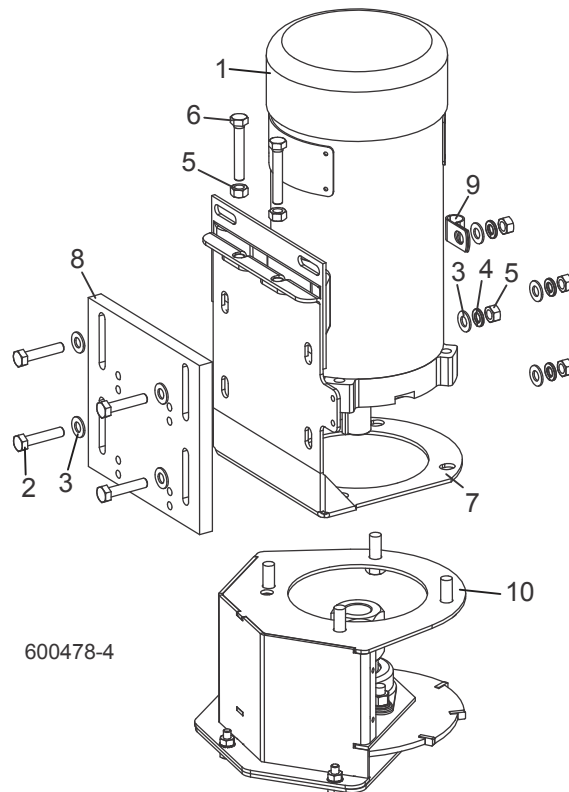

REF	DESCRIPTION (◆ Indicates Parts Available In Assemblies Only)	PART #	QTY.
	HEAD ASSEMBLY, LT70 DEBARKER CUTTING	076677	1
1	Motor, 3/4HP 12VDC TEFC Electric (7/8" Dia. Shaft)	023688	1
	Brush Kit, Leeson 3/4HP Motor (Includes 2 Brushes and 2 Springs)	024167	1
	Fan, 3/4 HP Leeson Motor Replacement	016087	1
	Guard, Motor Fan	047998	1
	Key, 3/16" Square x 1 3/8" Long	016108	1
2	Bolt, 5/16-18 x 1 1/2" Hex Head Full Thread	F05006-2	4
3	Washer, 5/16" SAE Flat	F05011-17	8
4	Washer, 5/16" Split Lock	F05011-13	4
5	Nut, 5/16-18 Hex	F05010-17	6
6	Bolt, 5/16-18 x 2" Hex Head Full Thread	F05006-13	2
7	Bracket Weldment, Debarker Blade Motor Adjustable	023622	1
8	Plate, Debarker Blade Motor Mount	023620	1
9	Clamp, 1/2EMT Coated	P07584	1
	Decal, Disconnect Motor Leads Warning	024431	1
10	Blade/Mandrel Parts (See Section 7.13)		

7.10 Cutter Head Assembly (DC)

MKII LT70 A.00 - B.03

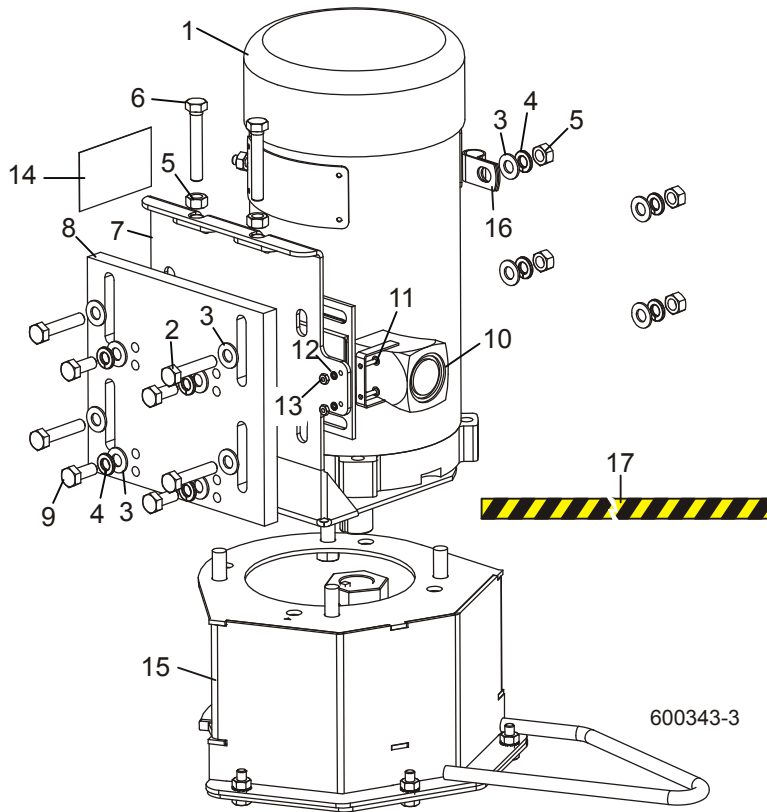

REF	DESCRIPTION (◆ Indicates Parts Available In Assemblies Only)	PART #	QTY.
	HEAD ASSEMBLY, MKII DEBARKER CUTTER (DC DCS)	025904	1
1	Motor, 3/4HP 12VDC TEFC Electric (7/8" Dia. Shaft)	023688	1
	Brush Kit, Leeson 3/4HP Motor (Includes 2 Brushes and 2 Springs)	024167	1
	Fan, 3/4 HP Leeson Motor Replacement	016087	1
	Guard, Motor Fan	047998	1
	Key, 3/16" Square x 1 3/8" Long	016108	1
2	Bolt, 5/16-18 x 1 1/2" Hex Head Full Thread	F05006-2	4
3	Washer, 5/16" SAE Flat	F05011-17	8
4	Washer, 5/16" Split Lock	F05011-13	8
5	Nut, 5/16-18 Hex	F05010-17	6
6	Bolt, 5/16-18 x 2" Hex Head Full Thread	F05006-13	2
7	Bracket Weldment, Debarker Blade Motor Adjustable	023622	1
8	Plate, Debarker Blade Motor Mount	023620	1
9	Bolt, 5/16-18 x 3/4" Hex Head Grade 2	F05006-5	4

7 **Debarker (DCS)**
Cutter Head Assembly (DC)

10	Horn Assembly, DCS Debarker On Warning	069431	1	
11	Screw, #4-40 x 1/2" Slotted Head	F05004-14	2	
12	Washer, #4 Split Lock	F05011-21	2	
13	Nut, #4-40 Hex	F05010-43	2	
14	Decal, Disconnect Motor Leads Warning	024431	1	
15	Blade/Mandrel Parts (See Section 7.14)			
16	Clamp, 1/2" EMT Coated	P07584	1	
17	Decal, LT15 Blade Guide Bar	015849	.5	

7.11 Cutter Head Assembly (AC)

MKIII LT70 A.00+

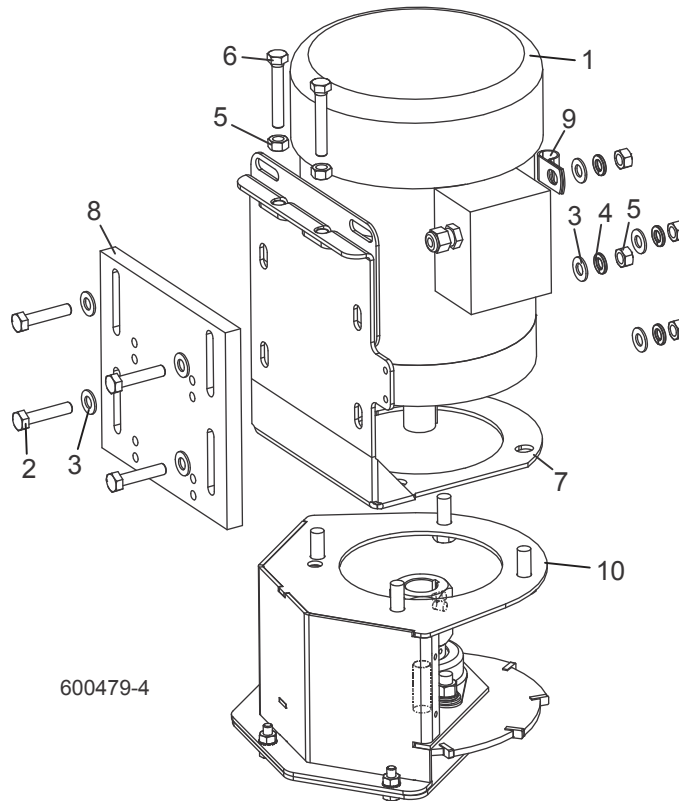

REF	DESCRIPTION (◆ Indicates Parts Available In Assemblies Only)	PART #	QTY.
	HEAD ASSEMBLY, LT70 AC DEBARKER CUTTING	074858	1
1	Motor, 3/4HP 230/460V 1725RPM Electric	050292	1
	Key, 3/16" Square x 1 3/8" Long	016108	1
2	Bolt, 5/16-18 x 1 1/2" Hex Head Full Thread	F05006-2	4
3	Washer, 5/16" SAE Flat	F05011-17	8
4	Washer, 5/16" Split Lock	F05011-13	4
5	Nut, 5/16-18 Hex	F05010-17	6
6	Bolt, 5/16-18 x 2" Hex Head Full Thread	F05006-13	2
7	Bracket Weldment, Debarker Blade Motor Adjustable	023622	1
8	Plate, Debarker Blade Motor Mount	023620	1
9	Clamp, 1/2EMT Coated	P07584	1
	Decal, Disconnect Motor Leads Warning	024431	1
10	Blade/Mandrel Parts (See Section 7.13)		

7.12 Cutter Head Assembly (AC)

MKII LT70 A.00 - B.03

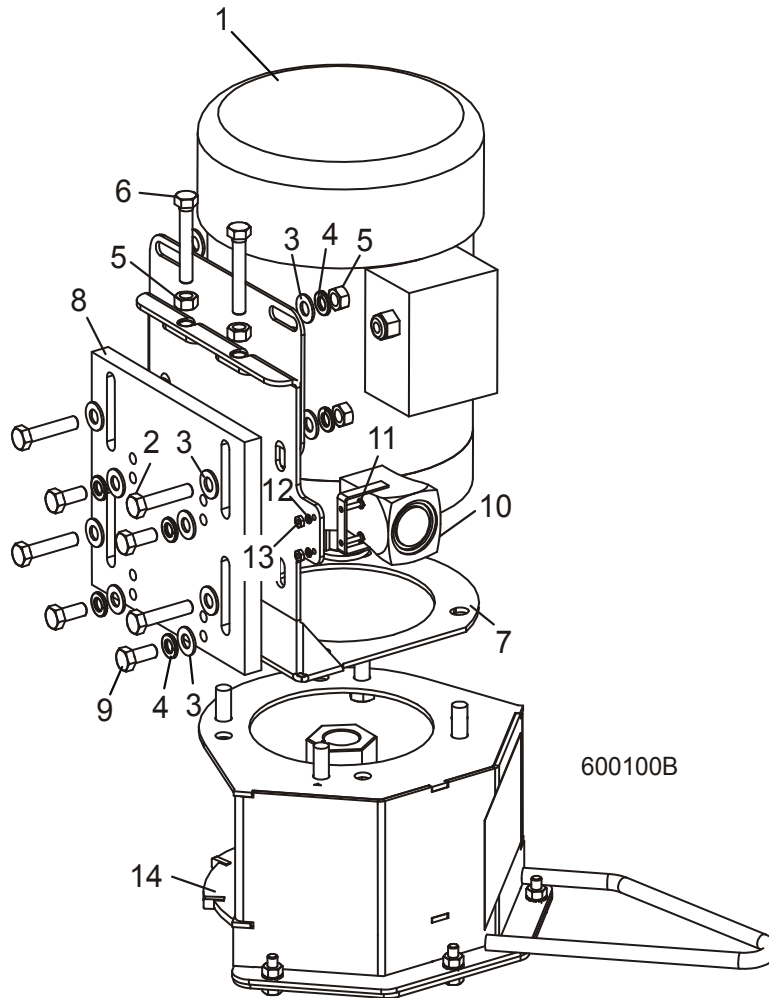

REF	DESCRIPTION (◆ Indicates Parts Available In Assemblies Only)	PART #	QTY.
	HEAD ASSEMBLY, MKII 230/460V AC DEBARKER CUTTING	017772	1
1	Motor, 3/4HP 230/460V 1725RPM Electric	050292	1
	Brush Kit, Leeson 3/4HP Motor (Includes 2 Brushes and 2 Springs)	024167	1
	Fan, 3/4 HP Leeson Motor Replacement	016087	1
	Guard, Motor Fan	047998	1
	Key, 3/16" Square x 1 3/8" Long	016108	1
2	Bolt, 5/16-18 x 1 1/2" Hex Head Full Thread	F05006-2	4
3	Washer, 5/16" SAE Flat	F05011-17	8
4	Washer, 5/16" Split Lock	F05011-13	8

Debarker (DCS)
Cutter Head Assembly (AC)

7

5	Nut, 5/16-18 Hex	F05010-17	6	
6	Bolt, 5/16-18 x 2" Hex Head Full Thread	F05006-13	2	
7	Bracket Weldment, Debarker Blade Motor Adjustable	023622	1	
8	Plate, Debarker Blade Motor Mount	023620	1	
9	Bolt, 5/16-18 x 3/4" Hex Head Grade 2	F05006-5	4	
10	Horn, Debarker On Warning	021137	1	
11	Screw, #4-40 x 1/2" Slotted Head	F05004-14	2	
12	Washer, #4 Split Lock	F05011-21	2	
13	Nut, #4-40 Hex	F05010-43	2	
14	Blade/Mandrel Parts (See Section 7.14)			

7.13 Blade Housing Assembly

MKIII LT70 A.00+

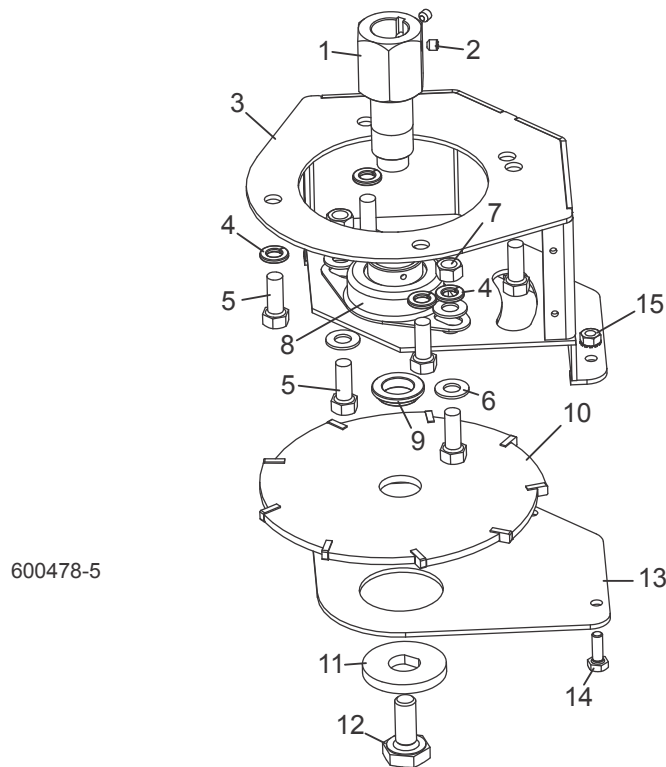

REF	DESCRIPTION (◆ Indicates Parts Available In Assemblies Only)	PART #	QTY.
1	MANDREL, DEBARKER BLADE	074832	1
2	SCREW, 1/4-28 X 1/4" CUP POINT SOCKET SET	F05005-105	2
3	HEAD WELDMENT, LT70 DEBARKER CUTTER	076686	1
4	WASHER, 3/8" SPLIT LOCK	F05011-4	6
5	BOLT, 3/8-16 X 1" HEX HEAD	F05007-7	6
6	WASHER, 3/8" SAE FLAT	F05011-3	4
7	NUT, 3/8-16 HEX	F05010-1	2
8	BEARING, 1" FLANGED MOUNT	023541	1
9	BUSHING, DEBARKER BLADE SPACER	023632	1
10	BLADE, DEBARKER 7" DIA.	021236	1
	BLADE, DEBARKER 7" DIA. W/1/2" INSERTS (OPTIONAL - SOLD SEPARATELY)	065852	1
11	WASHER, DEBARKER BLADE LOCK	023737	1
12	BOLT, 1/2-20 X 1 1/4" HEX HEAD SPECIAL	074833	1
13	PLATE, DEBARKER BLADE HOUSING BOTTOM	023629	1
14	BOLT, 1/4-20 X 3/4" HEX HEAD FULL THREAD	F05005-1	3
15	NUT, 1/4-20 SELF-LOCKING HEX	F05010-9	3
	DECAL, DEBARKER LIGHT WARNING	076799	1

7.14 Blade Housing Assembly

MKII LT70 A.00 - B.03

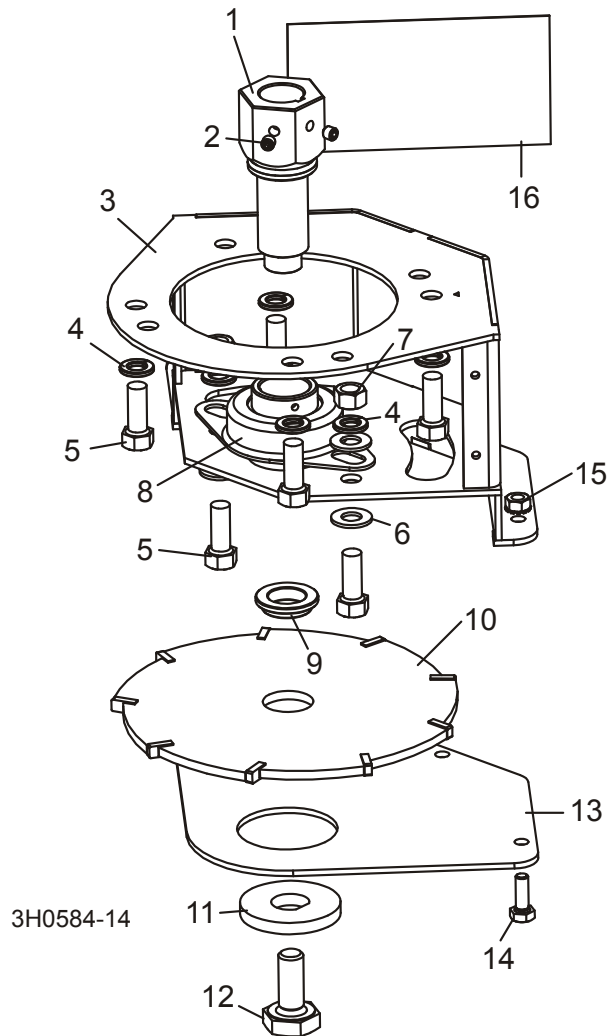

REF	DESCRIPTION (◆ Indicates Parts Available In Assemblies Only)	PART #	QTY.
1	MANDREL, DEBARKER BLADE (7/8" DIA.)	016122	1
2	SCREW, 1/4-28 X 1/4" CUP POINT SOCKET SET	F05005-105	2
3	HOUSING WELDMENT, DEBARKER BLADE	023628	1
4	WASHER, 3/8" SPLIT LOCK	F05011-4	6
5	BOLT, 3/8-16 X 1" HEX HEAD	F05007-7	6
6	WASHER, 3/8" SAE FLAT	F05011-3	4
7	NUT, 3/8-16 HEX	F05010-1	2
8	BEARING, 1" FLANGED MOUNT	023541	1
9	BUSHING, DEBARKER BLADE SPACER	023632	1
10	BLADE, DEBARKER 7" DIA.	021236	1

7 Debarker

Blade Housing Assembly

11	WASHER, DEBARKER BLADE LOCK	023737	1	
12	BOLT, 1/2-20 X 1 1/4" HEX HEAD SPECIAL	023547	1	
13	PLATE, DEBARKER BLADE HOUSING BOTTOM	023629	1	
14	BOLT, 1/4-20 X 3/4" HEX HEAD FULL THREAD	F05005-1	3	
15	NUT, 1/4-20 SELF-LOCKING HEX	F05010-9	3	
16	DECAL, DEBARKER HORN DANGER	021172	1	

7.15 Spring Arm Assembly

MKII LT70 A.00 - B.03

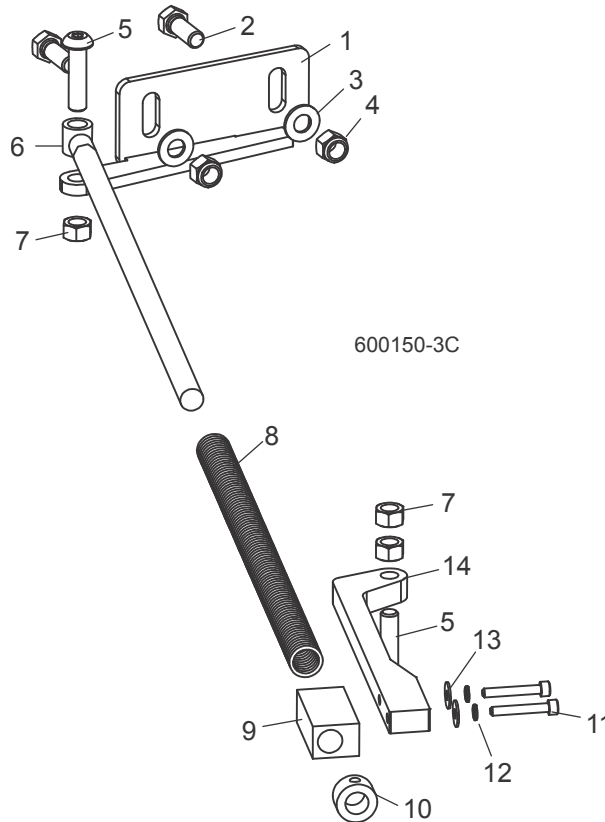

REF	DESCRIPTION (◆ Indicates Parts Available In Assemblies Only)	PART #	QTY.	
1	BRACKET, SPRING ROD MOUNT	045858	1	
2	BOLT, 3/8-16 X 1" HEX HEAD GRADE 5	F05007-87	2	
3	WASHER, 3/8" SAE FLAT	F05011-3	2	
4	NUT, 3/8-16 HEX NYLON LOCK	F05010-10	2	
5	BOLT, 3/8-16 X 1 1/4" SOCKET HEAD	F05007-150	2	
6	ROD WELDMENT, LT60 DEBARKER SPRING	045852	1	
7	NUT, 3/8-16 HEX LOCK	F05010-25	3	
8	SPRING, .72" OD X 19 1/2" X .08 WIRE	023631	1	
9	BLOCK, SPRING ROD SLIDE	045854	1	
10	COLLAR, 1/2" SHAFT	014820	1	
11	BOLT, #10-24 X 1 1/4" SOCKET HEAD	F05004-31	2	
12	WASHER, #10 SPLIT LOCK	F05011-20	2	
13	WASHER, #10 SAE FLAT	F05011-18	2	
14	ARM, SLIDE BLOCK MOUNT	046064	1	

SECTION 8 CONTROL & BATTERY BOXES

8.1 Control Assembly (DC)

LT70HD

Rev. B4.00+

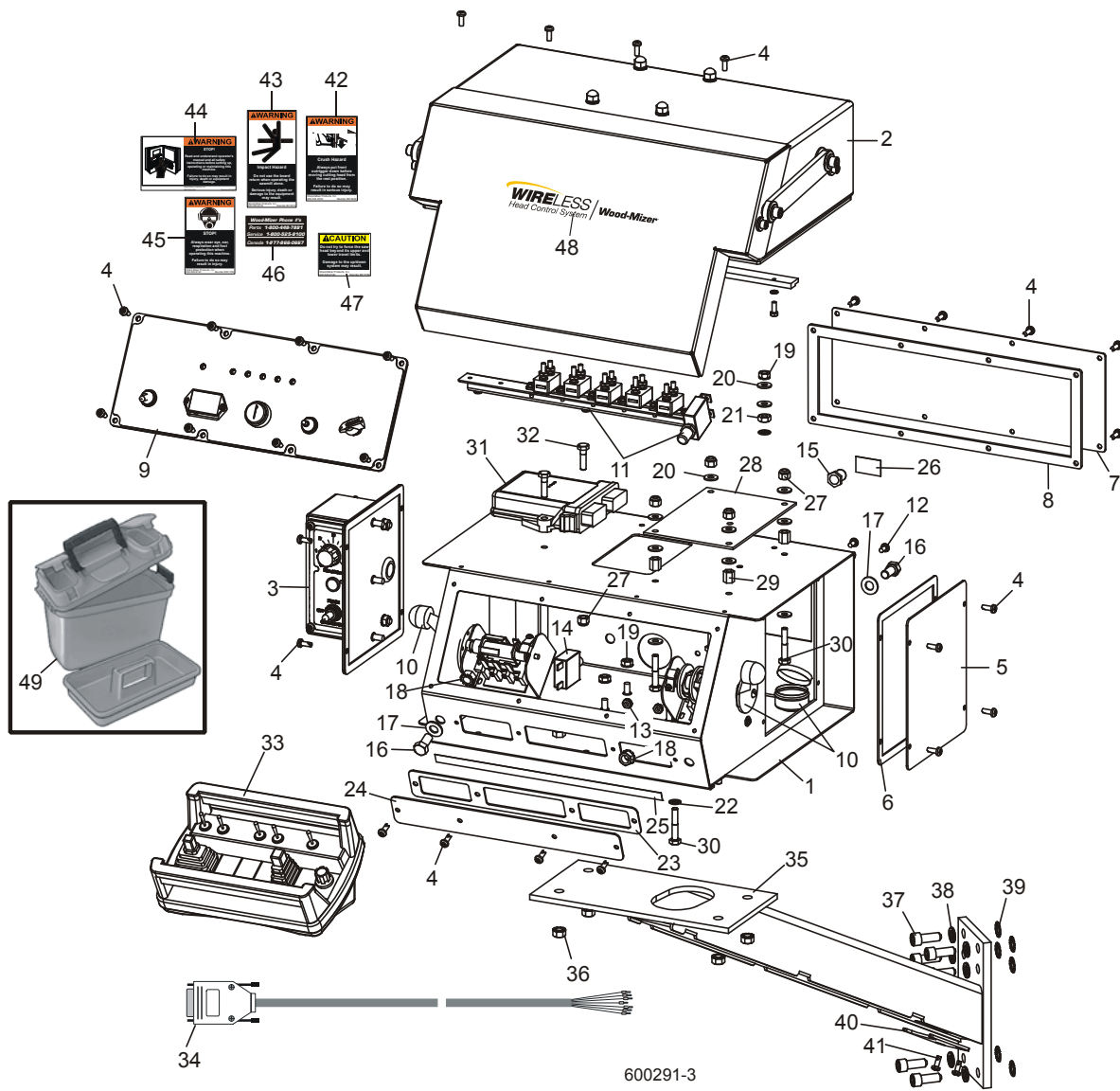

REF	DESCRIPTION (◆ Indicates Parts Available In Assemblies Only)	PART #	QTY.	
	COVER, SAWMILL CONTROL CONSOLE W/ACCUSET	036352	1	
	CONTROL BOX ASSEMBLY, D55 WIRELESS 2010 TIER 3	069390	1	
	CONTROL BOX ASSEMBLY, D51/D62 WIRELESS 2010	069390	1	
1	Box Weldment, Sawmill Control	057817 ¹	1	◆
2	Accuset Control Parts (See Accuset 2 option manual)			

3	LubeMizer Parts (See LubeMizer option manual)			
4	Screw, #10-24 x 1/2" Pan Head	F05015-17	32	
5	Panel Weldment, Side	006473	1	
6	Gasket, Side Panel Control	015274	1	
7	Plate, Rear Control Box	016230	1	
8	Gasket, Rear Panel	015278	1	
9	Front Control Panel & Wiring Harnesses (See Section 8.6)			
10	Drum Switches (See Section 8.4)			
11	Circuit Breakers (See Section 8.5)			
12	Screw, #10-24 x 3/8" Phillips Pan Head	F05004-3	2	
13	Nut, #10-24 Hex Self-Locking	F05010-14	2	
14	Breaker, 30A Manual Reset Panel Mount	024246	1	
15	Boot, Circuit Breaker	021253	1	
16	Bolt, 3/8-16 x 3/4" Hex Head	F05007-27	2	
17	Washer, 3/8" SAE Flat	F05011-3	2	
18	Nut, 3/8" Lock Nut	F05010-19	2	
19	Nut, 1/4-20 Self Locking	F05010-9	3	
20	Washer, 1/4 SAE Flat	F05011-11	14	
21	Nut, 1/4-20 Heavy-Duty Hex Jam	F05010-129	1	
22	Washer, 1/4" Interior Star Heavy-Duty Lock	F05011-69	2	
23	Gasket, Front Access Panel	015266	1	
24	Panel, Control Box Front Access	015376	1	
25	Decal, Circuit Breaker ID (LT70 2009)	053354	1	
26	Decal, Circuit Breaker ID (Autoclutch)	024366	1	
27	Nut, 1/4-20 Hex Nylon Lock	F05010-69	6	
28	PCB Assembly, Sawmill Wireless Interface	053148	1	
	Relay, 12A 12VDC DPDT	053144	7	
	Fuse, 10A ATO Blade Red	024150-10	1	
29	Standoff, 1/4 x 20 Female Threaded	053149	4	
30	Bolt, 1/4-20 x 1 1/2" Hex Head Full Thread	F05005-31	5	
31	Receiver Kit, Wireless R160 w/Instructions	053218	1	
32	Screw, 1/4-20 x 1" Hex Head	F05005-38	2	
33	Transmitter Kit, Wireless T300 w/Instructions	053217	1	
	Switch Kit, Omnex T300 Replacement E-Stop	053638	1	
	Switch Kit, Omnex T300 DT Momentary Toggle	053639	1	
	Switch Kit, Omnex T300 ST Maintained Toggle	053640	1	
	Switch Kit, Omnex T300 Variable Feed Potentiometer	053641	1	
	Potentiometer, Variable Feed (Not Omnex Part)	061054 ²	1	
	Switch Kit, Omnex T300 Up/Down Paddle	053642	1	
	Switch Kit, Omnex T300 Fwd/Rev/BG In-Out Joystick	053643	1	
	Harness, Wireless T300 Transmitter Orange Tear Away	053159	1	
34	Harness Assembly, Dual-Axis Motor Control Non-Remote	053355	1	
35	MOUNT WELDMENT, STANDARD CONTROL BOX	015236	1	

8

Control & Battery Boxes*Control Assembly (DC)*

36	NUT, 5/16-18 SELF-LOCKING HEX	F05010-20	4	
37	BOLT, 3/8-16 X 1" SOCKET HEAD	F05007-52	4	
38	WASHER, 3/8" SPLIT LOCK	F05011-4	4	
39	WASHER, 3/8" EXTERIOR STAR LOCK	F05011-36	4	
40	PLATE, PEDESTAL COVER	036381	1	
41	SCREW, #10-24 X 1/2" PAN HEAD	F05015-17	2	
42	DECAL, FRONT OUTRIGGER WARNING	015400	1	
43	DECAL, BOARD RETURN WARNING	016072	1	
44	DECAL, READ MANUAL WARNING	016402	1	
45	DECAL, EAR/EYE PROTECTION WARNING	S11753	1	
46	DECAL, 800 NUMBER	S12117	1	
47	DECAL, UP/DOWN CAUTION	S11762	1	
48	DECAL, WIRELESS HEAD CONTROL SYSTEM LOGO	057781	1	
49	BOX, PLASTIC WIRELESS CONTROL STORAGE	006472	1	

¹ Modified to better support PCB assembly. Round cut-out changed to rectangular (10/11).

² 061054 potentiometer can be used to replace 053641 Omnex T300 Variable Feed Potentiometer. The potentiometer is provided with no wires. The customer needs to solder the wires on when replacing the potentiometers.

8.2 Control Assembly (AC)

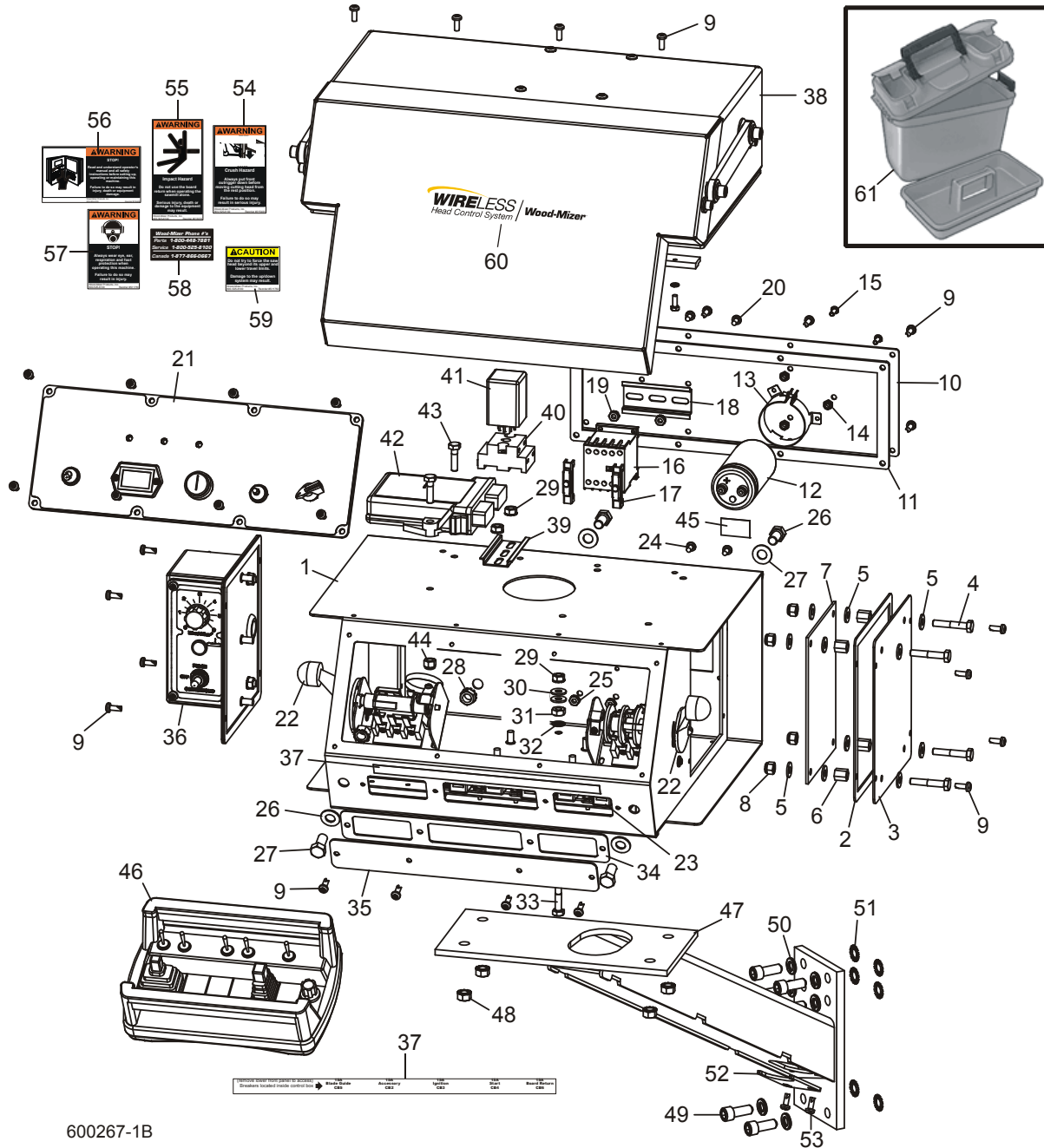

600267-1B

REF	DESCRIPTION (◆ Indicates Parts Available In Assemblies Only)	PART #	QTY.
	COVER, SAWMILL CONTROL CONSOLE W/ACCUNET	036352	1
	CONTROL BOX ASSEMBLY, E25/E30	053189 ¹	1
1	Box Weldment, Wireless AC Sawmill Control	057817	1
	Panel Assembly, Wireless AC Sawmill Side	053150	1

8

Control & Battery Boxes*Control Assembly (AC)*

2	Gasket, Side Access Panel	015274	1	
3	Panel Weldment, Side Access	057799	1	
4	Bolt, 1/4-20 x 1 1/2 Hex Head Full Thread	F05005-31	4	
5	Washer, 1/2" SAE Flat	F05011-11	12	
6	Standoff, 1/4" x 20 Female Threaded	053149	4	
7	PCB Assembly, Sawmill Wireless Interface	053148	1	
	Relay, 12A 12VDC DPDT	053144	7	
	Fuse, 10A ATO Blade Red	024150-10	1	
8	Nut, 1/4-20 Nylon Lock	F05010-69	4	
9	Screw, #10-24 x 1/2" Pan Head	F05015-17	32	
10	Panel, Rear Control Access	016230	1	
	Panel Assembly, Wireless AC Sawmill Back	053153	1	
11	Panel, Wireless Rear Control	057797	1	
12	Gasket, Rear Access Panel	015278	1	
13	Capacitor, 9600uF 40VDC	053152	1	
14	Bracket, Capacitor Mounting	053151	1	
15	Nut, #8-32 Hex Nylon Lock	F05010-169	3	
16	Relay, Control 2 NO 2NC 12VDC Low Power	050807	1	
17	Clamp, Plastic Din Rail	E22707	2	
18	Din Rail, 35mm x 7.5mm x 3" Steel	024474-3	1	
19	Nut, #10-24 Keps	F05010-14	2	
20	Screw, #10-24 x 3/8" Phillips	F05004-3	2	
21	Front Control Panel (See Section 8.6)			
22	Drum Switches (See Section 8.4)			
23	Circuit Breakers (See Section 8.5)			
24	Screw, #10-24 x 3/8" Phillips Pan Head	F05004-3	2	
25	Nut, #10-24 Self Locking	F05010-14	2	
26	Bolt, 3/8-16 x 3/4" Hex Head	F05007-27	4	
27	Washer, 3/8" SAE Flat	F05011-3	4	
28	Nut, 3/8" Lock Nut	F05010-19	4	
29	Nut, 1/4-20 Self Locking	F05010-9	3	
30	Washer, 1/4" SAE Flat	F05011-11	2	
31	Nut, 1/4-20 Jam Heavy Duty	F05010-129	2	
32	Washer, 1/4" Interior Star Heavy Duty	F05011-69	1	
33	Bolt, 1/4-20 x 1 1/2" Hex Head Full Thread	F05005-31	1	
34	Gasket, Front Access Panel	015266	1	
35	Panel, Control Box Front Access	015376	1	
36	LubeMizer Control Parts (See LubeMizer Manual)			
37	Decal, Circuit Breaker ID	050917	1	
	Decal, Circuit Breaker ID (Debarker In/Out)	050918	1	
38	Accuset Control Parts (See Accuset 2 option manual)			
39	Din Rail, 35mm x 7.5mm x 3" Steel	024474-3	1	
40	Socket, 8 Pin Relay	E10216	1	

41	Relay, DPDT 10A GP Tube Terminals	050300	1	
42	Receiver Kit, Wireless R160 w/Instructions	053218	1	
43	Screw, 1/4-20 x 1" Hex Head	F05005-38	2	
44	Screw, 1/4-20 Nylon Lock	F05010-69	2	
45	Decal, Breaker ID LT70E25 Debarker	050918	1	
46	Transmitter Kit, Wireless T300 w/Instructions	053217	1	
	Switch Kit, Omnex T300 Replacement E-Stop	053638	1	
	Switch Kit, Omnex T300 DT Momentary Toggle	053639	1	
	Switch Kit, Omnex T300 ST Maintained Toggle	053640	1	
	Switch Kit, Omnex T300 Variable Feed Potentiometer	053641	1	
	Potentiometer, Variable Feed (Not Omnex Part)	061054 ²	1	
	Switch Kit, Omnex T300 Up/Down Paddle	053642	1	
	Switch Kit, Omnex T300 Fwd/Rev/BG In-Out Joystick	053643	1	
	Harness, Wireless T300 Transmitter Orange Tear Away	053159	1	
	Harness Parts (See Section 8.6)			
47	MOUNT WELDMENT, STANDARD CONTROL BOX	015236	1	
48	NUT, 5/16-18 SELF-LOCKING HEX	F05010-20	4	
49	BOLT, 3/8-16 X 1" SOCKET HEAD	F05007-52	4	
50	WASHER, 3/8" SPLIT LOCK	F05011-4	4	
51	WASHER, 3/8" EXTERIOR STAR LOCK	F05011-36	4	
52	PLATE, PEDESTAL COVER	036381	1	
53	SCREW, #10-24 X 1/2" PAN HEAD	F05015-17	2	
54	DECAL, FRONT OUTRIGGER WARNING	015400	1	
55	DECAL, BOARD RETURN WARNING	016072	1	
56	DECAL, READ MANUAL WARNING	016402	1	
57	DECAL, EAR/EYE PROTECTION WARNING	S11753	1	
58	DECAL, 800 NUMBER	S12117	1	
59	DECAL, UP/DOWN CAUTION	S11762	1	
60	DECAL, WIRELESS HEAD CONTROL SYSTEM LOGO	057781	1	
61	BOX, PLASTIC WIRELESS CONTROL STORAGE	006472	1	

¹ Replaced 069570 Control Box Assembly, E30 Wide Head (Rev. B6.07).

² 061054 potentiometer can be used to replace 053641 Omnex T300 Variable Feed Potentiometer. The potentiometer is provided with no wires. The customer needs to solder the wires on when replacing the potentiometers.

8 Control & Battery Boxes

Control Assembly (DC)

8.3 Control Assembly (DC)

LT70HD

Rev. B3.02

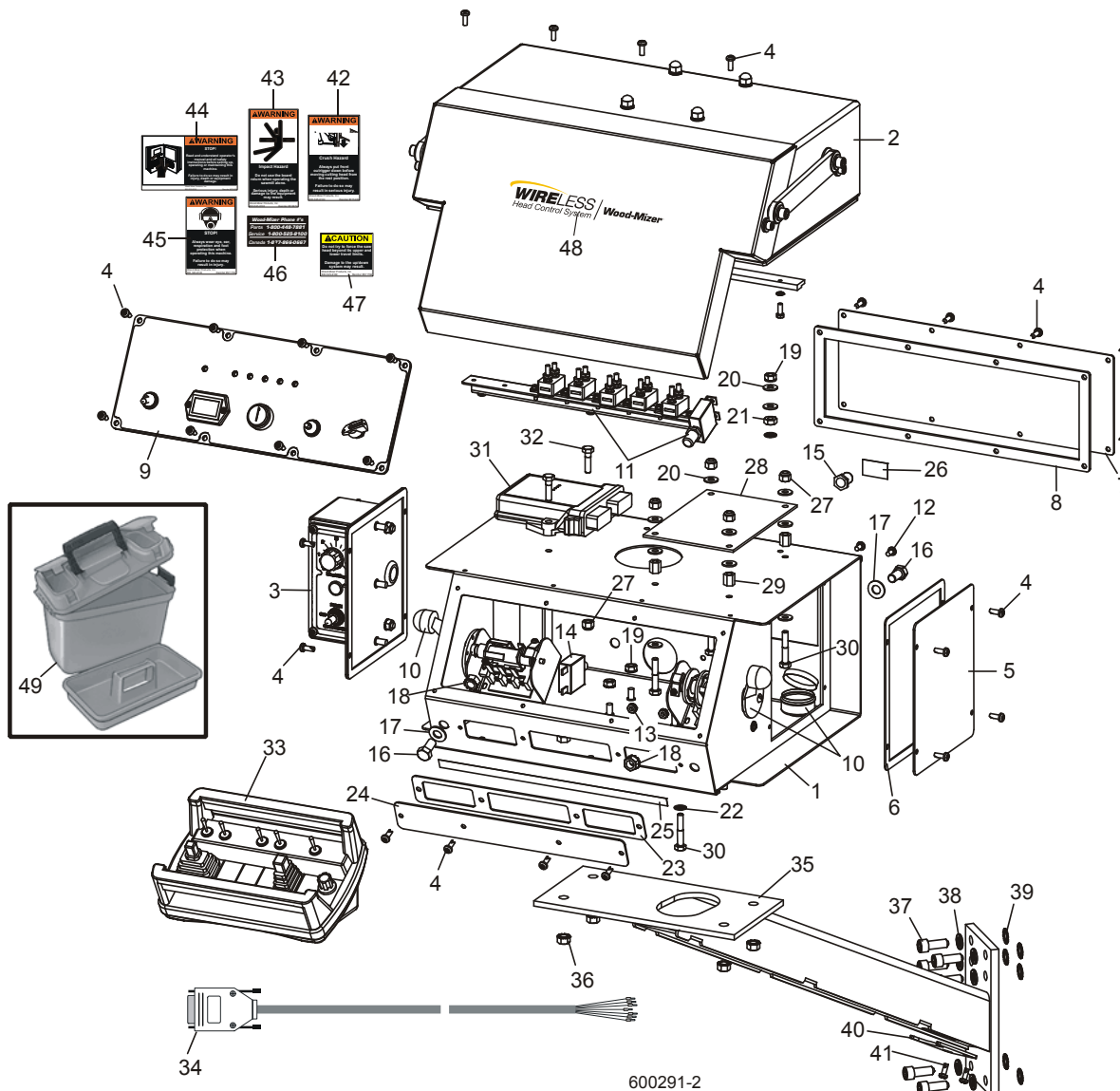

REF	DESCRIPTION (◆ Indicates Parts Available In Assemblies Only)	PART #	QTY.	
	COVER, SAWMILL CONTROL CONSOLE W/ACCUSET	036352	1	
	CONTROL BOX ASSEMBLY, D55 WIRELESS 2010	069334	1	
	CONTROL BOX ASSEMBLY, D51/D62 WIRELESS 2010	069333	1	
1	Box Weldment, Sawmill Control	057817	1	◆
2	Accuset Control Parts (See Accuset 2 option manual)			
3	LubeMizer Parts (See LubeMizer option manual)			
4	Screw, #10-24 x 1/2" Pan Head	F05015-17	32	
5	Panel Weldment, Side	006473	1	

6	Gasket, Side Panel Control	015274	1	
7	Plate, Rear Control Box	016230	1	
8	Gasket, Rear Panel	015278	1	
9	Front Control Panel & Wiring Harnesses (See Section 8.6)			
10	Drum Switches (See Section 8.4)			
11	Circuit Breakers (See Section 8.5)			
12	Screw, #10-24 x 3/8" Phillips Pan Head	F05004-3	2	
13	Nut, #10-24 Hex Self-Locking	F05010-14	2	
14	Breaker, 30A Manual Reset Panel Mount	024246	1	
15	Boot, Circuit Breaker	021253	1	
16	Bolt, 3/8-16 x 3/4" Hex Head	F05007-27	2	
17	Washer, 3/8" SAE Flat	F05011-3	2	
18	Nut, 3/8" Lock Nut	F05010-19	2	
19	Nut, 1/4-20 Self Locking	F05010-9	3	
20	Washer, 1/4 SAE Flat	F05011-11	14	
21	Nut, 1/4-20 Heavy-Duty Hex Jam	F05010-129	1	
22	Washer, 1/4" Interior Star Heavy-Duty Lock	F05011-69	2	
23	Gasket, Front Access Panel	015266	1	
24	Panel, Control Box Front Access	015376	1	
25	Decal, Circuit Breaker ID (LT70 2009)	053354	1	
26	Decal, Circuit Breaker ID (Autoclutch)	024366	1	
27	Nut, 1/4-20 Hex Nylon Lock	F05010-69	6	
28	PCB Assembly, Sawmill Wireless Interface	053148	1	
	Relay, 12A 12VDC DPDT	053144	7	
	Fuse, 10A ATO Blade Red	024150-10	1	
29	Standoff, 1/4 x 20 Female Threaded	053149	4	
30	Bolt, 1/4-20 x 1 1/2" Hex Head Full Thread	F05005-31	5	
31	Receiver Kit, Wireless R160 w/Instructions	053218	1	
32	Screw, 1/4-20 x 1" Hex Head	F05005-38	2	
33	Transmitter Kit, Wireless T300 w/Instructions	053217	1	
	Switch Kit, Omnex T300 Replacement E-Stop	053638	1	
	Switch Kit, Omnex T300 DT Momentary Toggle	053639	1	
	Switch Kit, Omnex T300 ST Maintained Toggle	053640	1	
	Switch Kit, Omnex T300 Variable Feed Potentiometer	053641	1	
	Potentiometer, Variable Feed (Not Omnex Part)	061054 ¹	1	
	Switch Kit, Omnex T300 Up/Down Paddle	053642	1	
	Switch Kit, Omnex T300 Fwd/Rev/BG In-Out Joystick	053643	1	
	Harness, Wireless T300 Transmitter Orange Tear Away	053159	1	
34	Harness Assembly, Dual-Axis Motor Control Non-Remote	053355	1	
35	MOUNT WELDMENT, STANDARD CONTROL BOX	015236	1	
36	NUT, 5/16-18 SELF-LOCKING HEX	F05010-20	4	
37	BOLT, 3/8-16 X 1" SOCKET HEAD	F05007-52	4	
38	WASHER, 3/8" SPLIT LOCK	F05011-4	4	

8

Control & Battery Boxes*Control Assembly (DC)*

39	WASHER, 3/8" EXTERIOR STAR LOCK	F05011-36	4	
40	PLATE, PEDESTAL COVER	036381	1	
41	SCREW, #10-24 X 1/2" PAN HEAD	F05015-17	2	
42	DECAL, FRONT OUTRIGGER WARNING	015400	1	
43	DECAL, BOARD RETURN WARNING	016072	1	
44	DECAL, READ MANUAL WARNING	016402	1	
45	DECAL, EAR/EYE PROTECTION WARNING	S11753	1	
46	DECAL, 800 NUMBER	S12117	1	
47	DECAL, UP/DOWN CAUTION	S11762	1	
48	DECAL, WIRELESS HEAD CONTROL SYSTEM LOGO	057781	1	
49	BOX, PLASTIC WIRELESS CONTROL STORAGE	006472	1	

¹ 061054 potentiometer can be used to replace 053641 Omnex T300 Variable Feed Potentiometer. The potentiometer is provided with no wires. The customer needs to solder the wires on when replacing the potentiometers.

8.4 Drum Switches

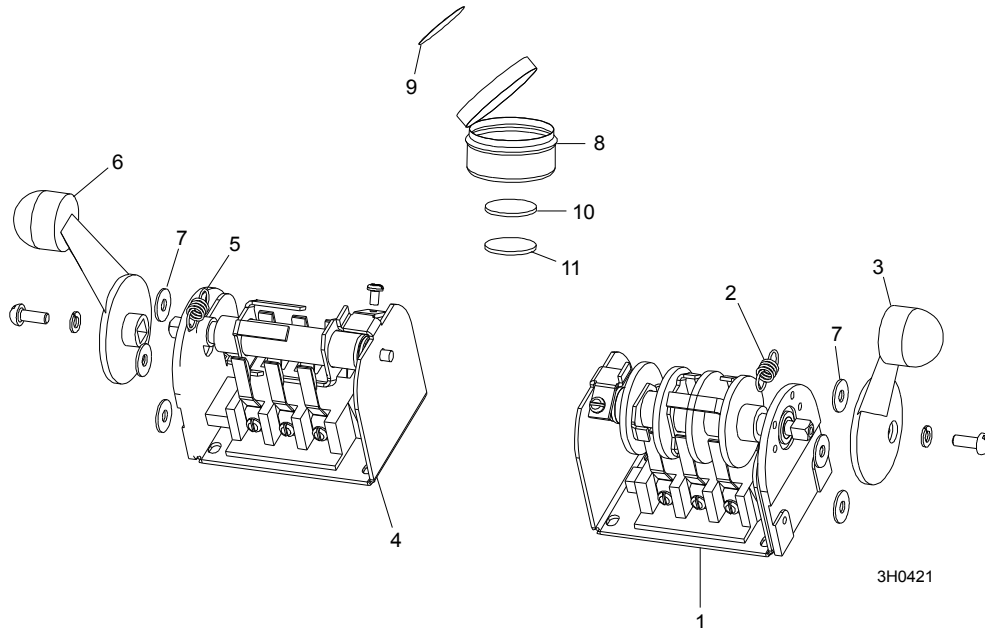

REF	DESCRIPTION (◆ Indicates Parts Available In Assemblies Only)	PART #	QTY.	
	SWITCH ASSEMBLY, UP/DOWN DRUM	E20440	1	
1	Switch, S12 Bulk Drum	E20440-B	1	◆
2	Spring, Drum Switch	P12570	1	
3	Handle, Drum Switch Replacement	P12500	1	
	SWITCH ASSEMBLY, POWER FEED DRUM	E20439	1	
4	Switch, S11 Bulk Drum	E20439-B	1	◆
5	Spring, Drum Switch	P12570	1	
6	Handle, Drum Switch Replacement	P12500	1	
7	WASHER, #8 SAE FLAT	F05011-41	6	
	CUP ASSEMBLY, DRUM SWITCH GREASE	A20463	1	
8	Cup, Plastic Container	P20464	1	◆
9	Decal, Grease Cup Label	P20467	1	
10	Pad, Velcro Loop	P20466	1	◆
11	Pad, Velcro Hook	P20465	1	◆
	Grease, High Temp Drum Switch	P20468	.025 lb	◆

8.5 Circuit Breakers

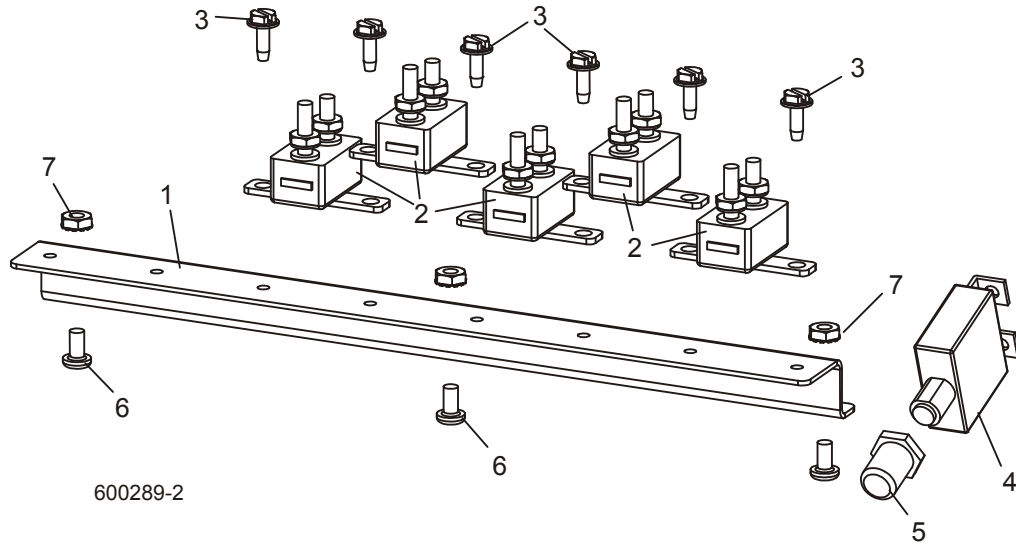

REF	DESCRIPTION (◆ Indicates Parts Available In Assemblies Only)	PART #	QTY.
	BREAKER ASSEMBLY, SAWMILL CONTROL CIRCUIT (DC)	015621	1
	BREAKER ASSEMBLY, SAWMILL CONTROL CIRCUIT (AC)	050916	1
1	Rail, Circuit Breaker	052826	1
2	Breaker, 15 Amp Manual Reset	E20430	5
3	Screw, #10-24 x 1/2" Self-Tapping	F05015-7	6
4	BREAKER, 70 AMP MANUAL RESET PANEL MOUNT (DC ONLY)	015527	1
5	BOOT, CIRCUIT BREAKER	021253	1
6	SCREW, #10-24 X 3/8" PHILLIPS PAN HEAD	F05004-3	3
7	NUT, #10-24 SELF LOCKING	F05010-14	3

8.6 Front Panel Assembly & Harnesses

LT70HD

Rev. B4.00+

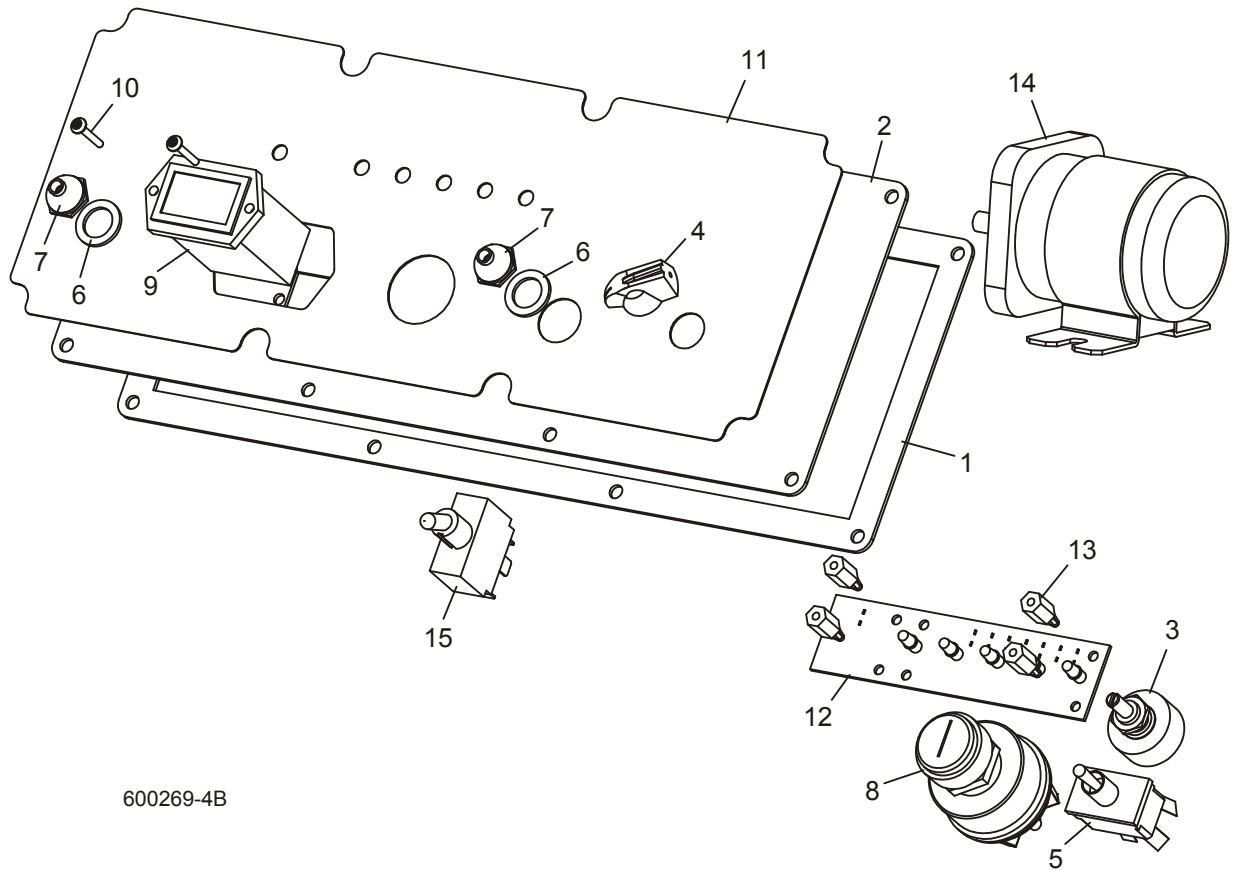

600269-4B

REF	DESCRIPTION (◆ Indicates Parts Available In Assemblies Only)	PART #	QTY.
	PANEL ASSEMBLY, CONTROL FRONT D51/D55/D62	051877	1
	PANEL ASSEMBLY, CONTROL FRONT E25/E30	050299	1
1	Gasket, Front Panel	015270	1
2	Panel Weldment, Control	015302	1
3	Switch Assembly, Feed Rate	024450-1	1
4	Knob, Feed Rate With Set Screw	P06257	1
5	Switch, Toggle	024200	1
6	Boot, Toggle Switch Rubber	P02575	2
7	Washer, 12 x 3/4 x 1/16 Nylon	P05251-1	2
8	Switch, Key	P04350	1
9	Meter, Hour	015401	1
10	Screw, #6-32 x 1/2" Plain PH T23	F05015-28	2
11	Decal, Control Panel (E25/E30)	015271	1
	Decal, Control Panel (D51/D55/D62)	015269	1

8

Control & Battery Boxes

Front Panel Assembly & Harnesses

12	Board, LED Circuit (E25/E30)	015416	1	
	Board, LED Circuit (D51/D55/D62)	015409	1	
13	Spacer, 1/2"-#6 Threaded	023147	4	
14	Solenoid Kit, 200A 12V SPST Cont. Duty	016371	1	
	Solenoid, 200A 12V SPST Cont. Duty	015470	1	◆
	Diode Assembly, Solenoid Coil Chassis Gnd	015426	1	
15	Switch, Blade Start/Stop	051346	1	
	FUSEHOLDER, YANMAR D55T3 ENG FEED REPLACEMENT (D55 ONLY)	052164-D55T3	1	
	FUSE, 10A ATO RED BLADE (D55 ONLY)	024150-10	1	
	HARNESS ASSEMBLY, UPPER WIRING (D55 TIER 3)	069387	1	
	Wire Assembly, Yanmar D55 Tier3 Throttle (See D55 manual for relay parts)	069385	1	
	HARNESS ASSEMBLY, UPPER WIRING (D51/D62)	069316	1	
	HARNESS ASSEMBLY, UPPER WIRING (E25/E30)	053197	1	
	HARNESS ASSEMBLY, UPPER WIRING (E30 WIDE HEAD)	069564	1	
	Conduit, 1 1/4" x 58" Flex	050399	1	
	Connector, 1 1/4" Straight Male Metal Conduit	024402	1	
	Cable Assembly, AC LT70 Power Feed Service (E25/E30 Only)	052859	1	
	Cable Assembly, AC Drive Interface (E25/E30 Only)	053192	1	
	HARNESS ASSEMBLY, LOWER WIRING	051872	1	
	Conduit, 1/2" Expandable Black	R02374	41 in.	
	Conduit, 1/2" Expandable Black	R02374	42 in.	

8.7 Front Panel Assembly & Harnesses

LT70HD

Rev. B3.02

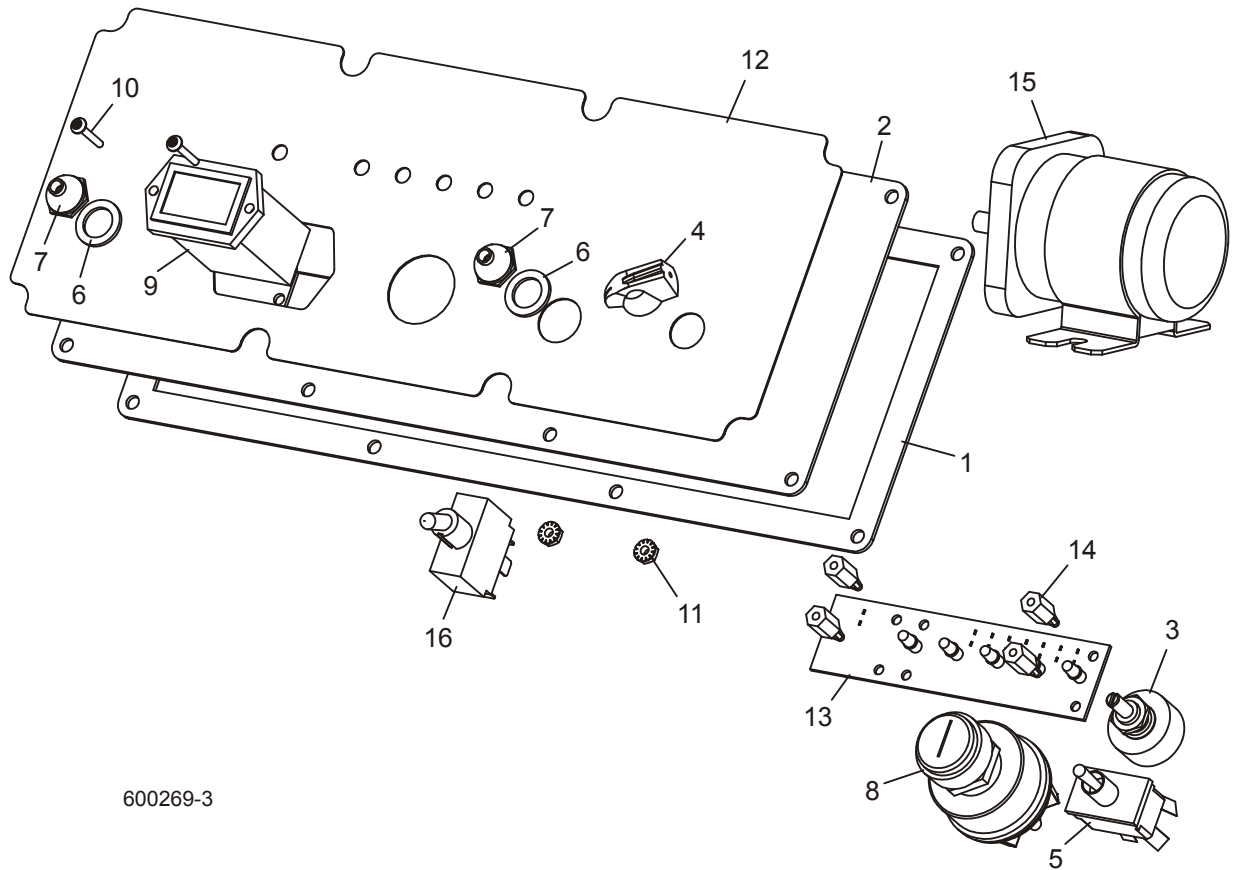

600269-3

REF	DESCRIPTION (◆ Indicates Parts Available In Assemblies Only)	PART #	QTY.
	PANEL ASSEMBLY, CONTROL FRONT D51/D55/D62	051877	1
	PANEL ASSEMBLY, CONTROL FRONT E25	050299	1
1	Gasket, Front Panel	015270	1
2	Panel Weldment, Control	015302	1
3	Switch Assembly, Feed Rate	024450-1	1
4	Knob, Feed Rate With Set Screw	P06257	1
5	Switch, Toggle	024200	
6	Boot, Toggle Switch Rubber	P02575	2
7	Washer, 12 x 3/4 x 1/16 Nylon	P05251-1	2
8	Switch, Key	P04350	1
9	Meter, Hour	015401	1
10	Screw, 6-42 x 3/4" Socket Button Head Cap Stainless Steel	F05004-93	2
11	Nut, 6-32 Self Locking	F05010-59	2

8

Control & Battery Boxes

Front Panel Assembly & Harnesses

12	Decal, Control Panel (E25)	015271	1	
	Decal, Control Panel (D51/D55/D62)	015269	1	
13	Board, LED Circuit (E25)	015416	1	
	Board, LED Circuit (D51/D55/D62)	015409	1	
14	Spacer, 1/2"-#6 Threaded	023147	4	
15	Solenoid Kit, 200A 12V SPST Cont. Duty	016371	1	
	Solenoid, 200A 12V SPST Cont. Duty	015470	1	◆
	Diode Assembly, Solenoid Coil Chassis Gnd	015426	1	
	Fuse Assembly, 2004 ATO w/Holder	051871	1	
	Fuse, 4A ATO Blade Pink	024150-4	1	
16	Switch, Blade Start/Stop	051346	1	
	HARNESS ASSEMBLY, UPPER WIRING (D55)	069317	1	
	HARNESS ASSEMBLY, UPPER WIRING (D51/D62)	069316	1	
	HARNESS ASSEMBLY, UPPER WIRING (E25)	053197	1	
	Conduit, 1 1/4" x 58" Flex	050399	1	
	Connector, 1 1/4" Straight Male Metal Conduit	024402	1	
	Cable Assembly, AC LT70 Power Feed Service (E25 Only)	052859	1	
	Cable Assembly, AC Drive Interface (E25 Only)	053192	1	
	HARNESS ASSEMBLY, LOWER WIRING	051872	1	
	Conduit, 1/2" Expandable Black	R02374	41 in.	
	Conduit, 1/2" Expandable Black	R02374	42 in.	

8.8 Battery Box Assembly (DC Only)

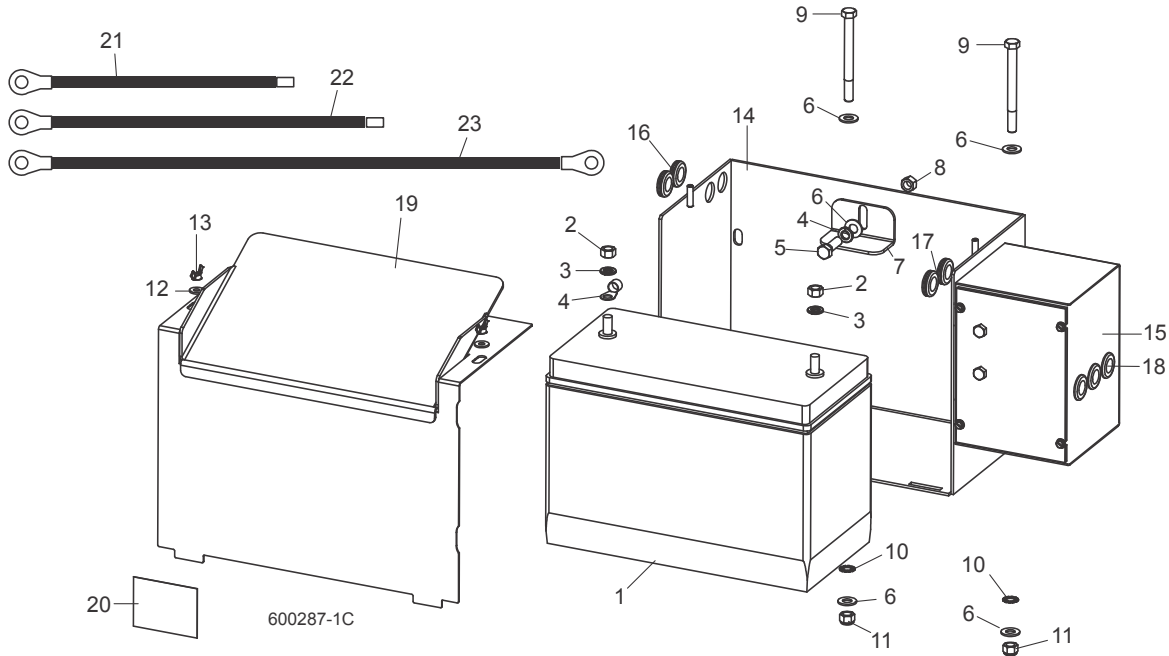

REF	DESCRIPTION (◆ Indicates Parts Available In Assemblies Only)	PART #	QTY.	
1	BATTERY, 12 VOLT 8A31DTM AGM	025841 ¹	1	◆
	BOX ASSEMBLY, LT60/70 BATTERY	017674 ²	1	
2	Nut, 3/8-16 Hex	F05010-1	1	
3	Washer, 3/8" Split Lock	F05011-4	3	
4	Terminal, 3/8 1-2 Ga Ring NI Loose	F05092-28	1	
5	Bolt, 3/8-16 x 1 1/4" Hex Head	F05007-2	1	
6	Washer, 3/8" SAE Flat	F05011-3	5	
7	Bracket, Battery Hold-Down	017725	1	
8	Nut, 3/8-16 Hex Lock	F05010-25	1	
9	Bolt, 3/8-16 x 4" Hex Head	F05007-4	2	
10	Washer, 3/8" External Star Lock	F05011-36	2	
11	Nut, 3/8" Hex Nylon Lock	F05010-10	2	
12	Washer, 1/4" SAE Flat	F05011-11	2	
13	Nut, 1/4-20 Wing	F05010-13	2	
14	Box Weldment, Battery	015191	1	
15	Fuse Box Parts (See Section 8.9)			
16	Grommet, 5/8" Rubber Wire	P11764	2	
17	Grommet, 3/4" ID 11 Gauge Thickness	074198	2	
18	Grommet, 3/4" ID 16 Gauge Thickness	074199	2	
19	LID WELDMENT, BATTERY BOX	033976	1	

8

Control & Battery Boxes

Battery Box Assembly (DC Only)

20	DECAL, BATTERY BOX LID CAUTION	014774	1	
21	CABLE ASSEMBLY, 1 GA X 12" 150A FUSE TO BATTERY POSITIVE	036308	1	
22	CABLE ASSEMBLY, 1 GA X 16" 225A FUSE TO BATTERY POSITIVE	036309	1	
23	CABLE ASSEMBLY, 1 GA X 26" BATTERY NEGATIVE TO NEG. CONTACT	036306	1	

¹ Replaces 12 Volt Battery (015475) supplied prior to Rev. B4.06. 12 Volt Battery (015475) changed to be equipped with one threaded stud (5/11).

² Battery terminals (P05085), (2) 1/4-20 x 3/4" hex head full thread bolts (F05005-1), washer (P12161), 1/4" exterior star washer (F05011-37) and 1/4-20 hex self-locking nut (F05010-9) replaced with ring terminals and fasteners for batteries with threaded studs (5/11).

8.9 Fuse Box Assembly (DC Only)

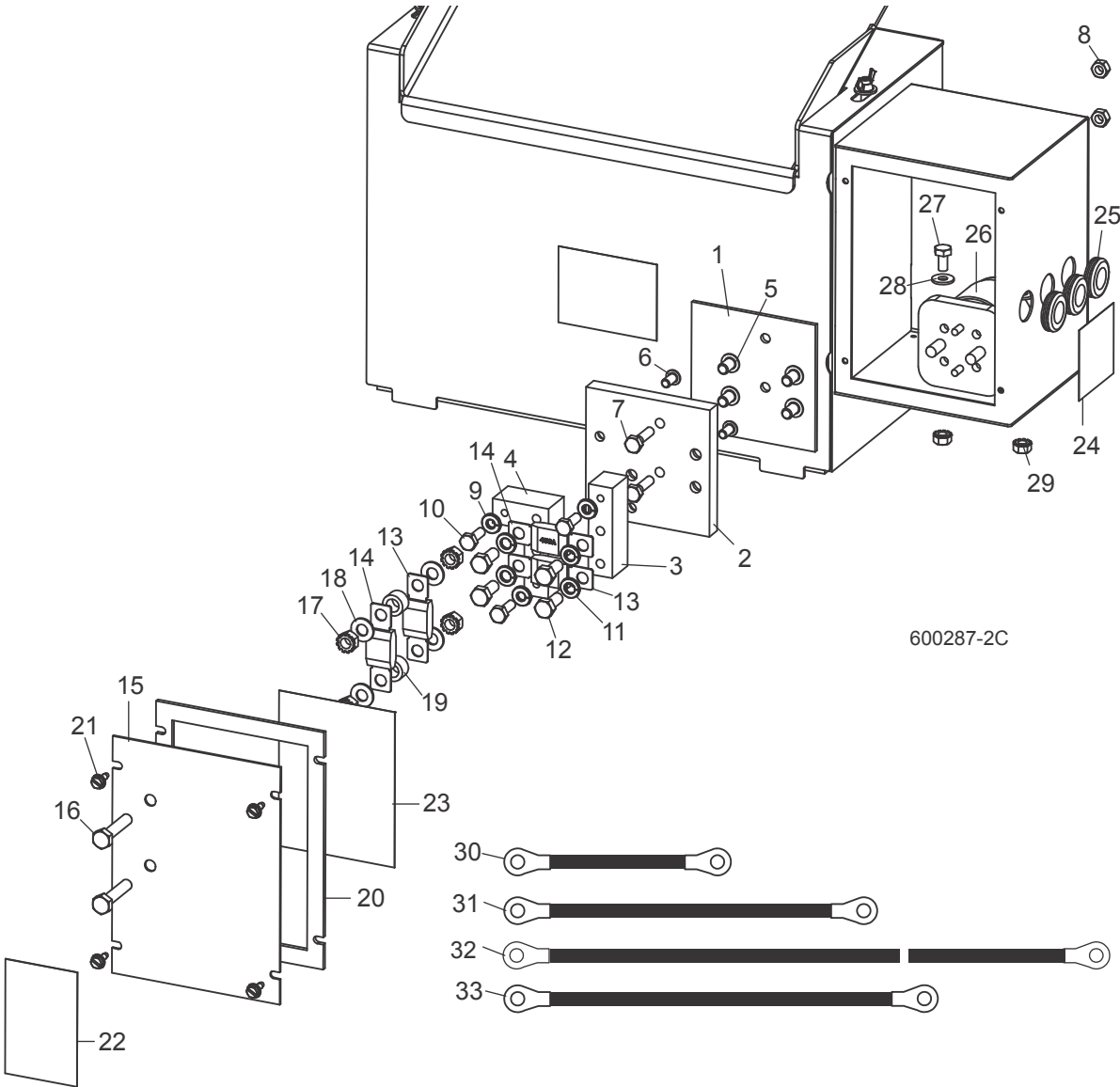

600287-2C

REF	DESCRIPTION (◆ Indicates Parts Available In Assemblies Only)	PART #	QTY.	
	BLOCK ASSEMBLY, DOUBLE FUSE	006795	1	
1	Plate, Fuse Block Insulator	056999	1	
2	Block, Fuse Mount	056997	1	◆
3	Block, 3/4" Upper Fuse	056996	1	
4	Block, 3/4" Lower Fuse	056998	2	
5	Screw, 5/16-18 x 1/2" Socket Button Head	F05006-20	4	
6	Screw, 1/4-20 x 1/2" Socket Button Head	F05005-59	2	
7	Bolt, 1/4-20 x 1" Hex Head Grade 5	F05005-101	2	

8

Control & Battery Boxes*Fuse Box Assembly (DC Only)*

8	Nut, 1/4-20 Hex Lock	F05010-21	2	
9	Washer, 1/4" Split Lock	F05011-14	3	
10	Bolt, 1/4-20 x 3/4" Hex Head Grade 5	F05005-123	3	
11	Washer, 5/16" Split Lock	F05011-13	4	
12	Bolt, 5/16-18 x 3/4" Hex Head Grade 5	F05006-102	4	
13	FUSE, 225A 32V MEGA	053339	2	
14	FUSE, 450A 32V MEGA	053340	2	
	COVER ASSEMBLY, DOUBLE FUSE BOX	006853	1	
15	Cover, Fuse Box	006851	1	
16	Bolt, 5/16-18 x 1 1/2" Hex Head Full Thread	F05006-2	2	
17	Nut, 5/16-18 Hex Self-Locking	F05010-20	4	
18	Washer, 5/16" SAE Flat	F05011-17	4	
19	Spacer, .39" x .625" x .39"	055323	2	
20	Gasket, Fuse Box Cover	050283	1	
21	SCREW, #10-24 X 1/2" SELF-TAPPING	F05015-7	4	
22	DECAL, 12 VOLT WARNING	P10364	1	
23	DECAL, 225/450A MEGA FUSE ID	006868	1	
24	DECAL, HYDRAULIC CONTACT CAUTION	P12960	1	
25	GROMMET, 5/8" RUBBER WIRE	P11764	3	
26	SOLENOID KIT, 200A 12V SPST CONT. DUTY	016371	1	
	Solenoid, 200A 12V SPST Cont. Duty	015470	1	◆
	Diode Assembly, Solenoid Coil Chassis Gnd	015426	1	
	WIRE ASSEMBLY, HYDRAULIC SOLENOID VOLTAGE DROP	024451	1	
27	BOLT, 1/4-20 X 1/2" HEX HEAD	F05005-15	2	
28	WASHER, 1/4" SAE FLAT	F05011-11	2	
29	NUT, 1/4-20 SELF-LOCKING HEX	F05010-9	4	
30	CABLE ASSEMBLY, 1 GA X 6 1/2" FUSE TO SOLENOID	036305	1	
31	CABLE ASSEMBLY, 1 GA X 14" SOLENOID TO POSITIVE CONTACT	036307	1	
32	CABLE ASSEMBLY, 1 GA X 26" BATT. NEGATIVE TO GROUND CONTACT	036306	1	
33	CABLE ASSEMBLY, 1 GA X 16" 225A FUSE TO BATTERY POSITIVE	036309	1	

SECTION 9 UP/DOWN SYSTEM

9.1 Up/Down Rollers & Covers

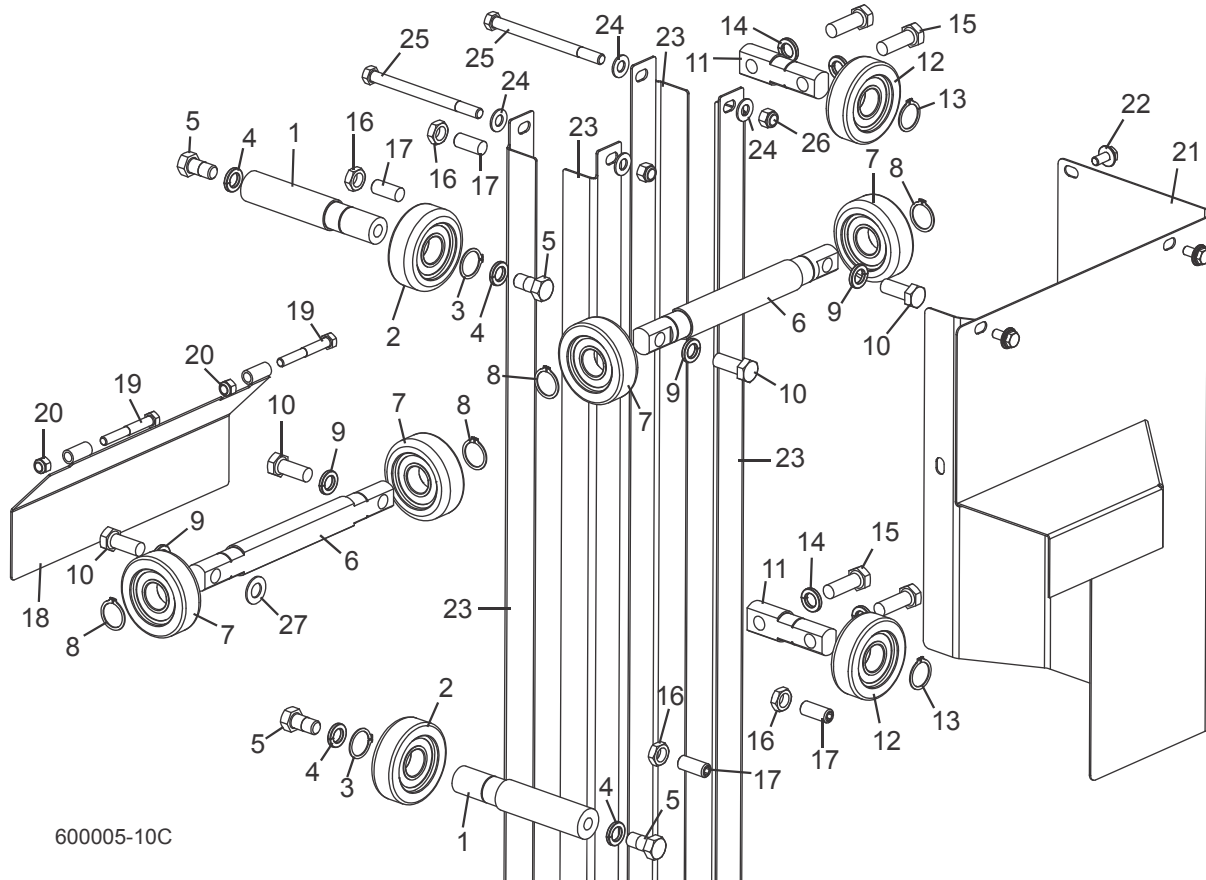

600005-10C

REF	DESCRIPTION (◆ Indicates Parts Available In Assemblies Only)	PART #	QTY.
	ROLLER ASSEMBLY, INSIDE UP/DOWN	034339	2
1	Shaft, Inside Up/Down Roller	033855	1
2	Bearing, MG305DDA	023857	1
3	Ring, 1" Outside Retaining	F04254-15	1
4	Washer, 1/2" Split Lock	F05011-9	2
5	Bolt, 1/2-13 x 1" Hex Head Grade 2	F05008-50	2
	ROLLER ASSEMBLY, LONG UP/DOWN	034337	2
6	Shaft, Long Up/Down Roller	033853	1
7	Bearing, MG305DDA	023857	2
8	Ring, 1" Outside Retaining	F04254-15	2
9	Washer, 1/2" Split Lock	F05011-9	2
10	Bolt, 1/2-13 x 1 1/4" Hex Head Grade 5	F05008-37	2
	ROLLER ASSEMBLY, SHORT UP/DOWN	034338	2



Up/Down System

Up/Down Rollers & Covers

11	Shaft, Short Up/Down Roller	033854	1	
12	Bearing, MG305DDA	023857	1	
13	Ring, 1" Outside Retaining	F04254-15	1	
14	Washer, 1/2" Split Lock	F05011-9	2	
15	Bolt, 1/2-13 x 1 1/2" Hex Head Grade 5	F05008-33	2	
16	NUT, 1/2-13 HEX JAM	F05010-31	4	
17	SCREW, 1/2-13 X 1 1/4" BRASS TIP SET	F05008-18	4	
18	COVER WELDMENT, LOWER UP/DOWN ROLLER	034277	1	
19	BOLT, 5/16-18 X 2 1/2" HEX HEAD GRADE 5	F05006-80	2	
20	NUT, 5/16-18 NYLON LOCK	F05010-58	2	
21	COVER WELDMENT, UP/DOWN DRIVE (D51/D55/D62)	036182	1	
	COVER WELDMENT, UP/DOWN DRIVE (E25/E30)	036184	1	
22	BOLT, 5/16-18 X 3/4" HEX WASHER HEAD	F05006-101	4	
23	ANGLE, MAST TUBE STAINLESS	033827	4	
24	WASHER, 3/8" SAE FLAT	F05011-3	8	
25	BOLT, 3/8-16 X 5" HEX HEAD	F05007-5	4	
26	NUT, 3/8-16 NYLON LOCK	F05010-10	4	
27	WASHER, .53 X 1.00 X .06	074563	1	

9.2 Blade Height & Quarter Scales

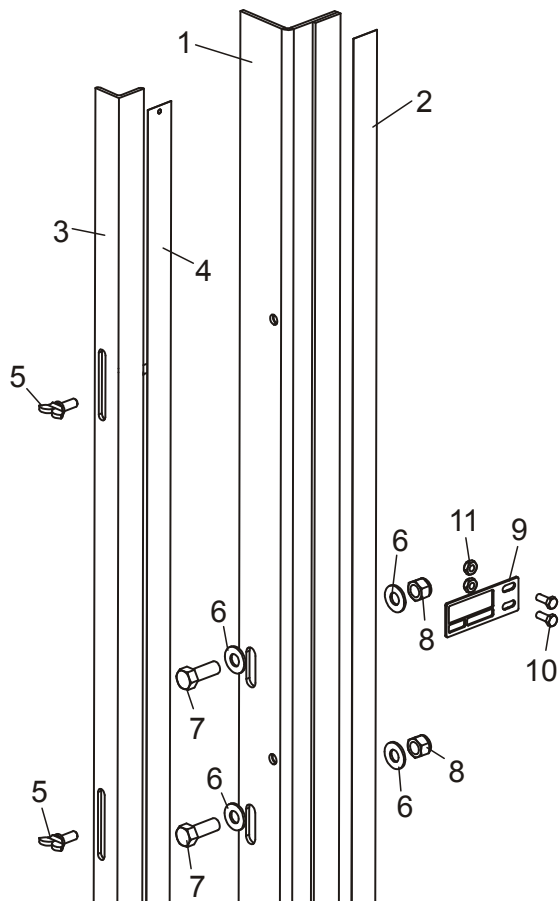

600123-2

REF	DESCRIPTION (◆ Indicates Parts Available In Assemblies Only)	PART #	QTY.
	SCALE ASSEMBLY, LT60/70	034372	1
1	Angle Weldment, Scale Mount	034370	1
2	Decal, Movable Inch Scale	S11773	1
	Scale Assembly, LT60/70 Quarter	034371	1
3	Angle, Quarter Scale Mount	034369	1
4	Decal, Movable Grade Quarter Scale	P12819 ¹	1
5	Screw, 1/4-20 x 5/8" Wing	F05005-64	2
6	Washer, 3/8" SAE Flat	F05011-3	4
7	Bolt, 3/8-16 x 1" Hex Head	F05007-7	2
8	Nut, 3/8-16 Hex Nylon Lock	F05010-10	2
9	INDICATOR, BLADE HEIGHT	017778	1
10	SCREW, #10-24 X 1/2" HEX HEAD STAINLESS STEEL	F05004-27	2
11	NUT, #10-24 SELF-LOCKING HEX	F05010-160	2

¹ Grade Quarter Scale Decal P12819 provided with sawmill. Standard Quarter Scale Decal S11774 available separately. Order Angle Mount 034369 and Standard Quarter Scale Decal S11774.

9.3 Up/Down Chain & Sprockets

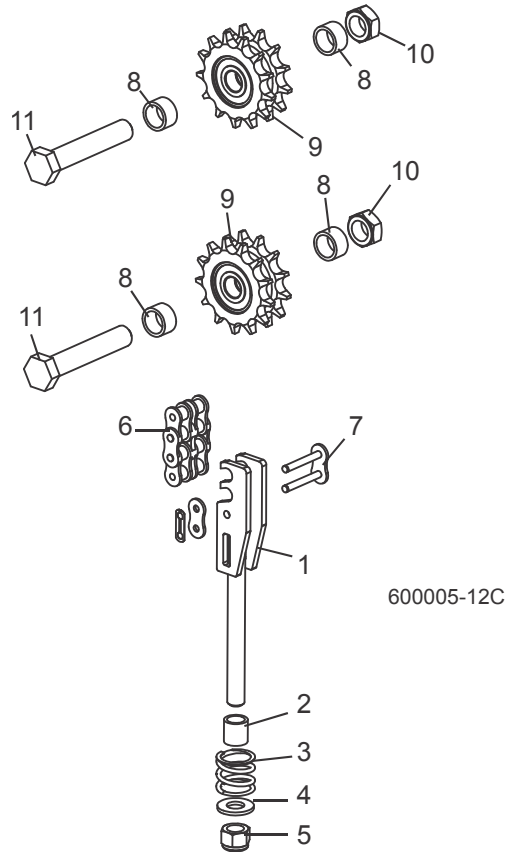

REF	DESCRIPTION (◆ Indicates Parts Available In Assemblies Only)	PART #	QTY.
	TENSIONER ASSEMBLY, LT60/70 UP/DOWN CHAIN	034238	1
1	Tensioner Weldment, Up/Down Chain	034236	1
2	Spacer, Up/Down Chain Tensioner	016515	1
3	Spring, 1" OD x 1" Long x .125 Wire Compression	016516	1
4	Washer, 1/2" SAE Flat	F05011-2	1
5	Nut, 1/2-13 Nylon Lock	F05010-8	1
6	CHAIN, LT60/70 UP/DOWN #50-2 X 73 1/8"	036197	1
7	LINK, #50-2 MASTER	015258	2
8	SPACER, #50-2 IDLER	016018	4
9	SPROCKET ASSEMBLY, #50-2 UP/DOWN IDLER	016019	2
10	NUT, 5/8-11 HEX NYLON LOCK JAM	F05010-96	2
11	BOLT, 5/8-11 X 3 1/2" HEX HEAD GRADE 5	F05009-93	2

9.4 Up/Down Drive Assembly

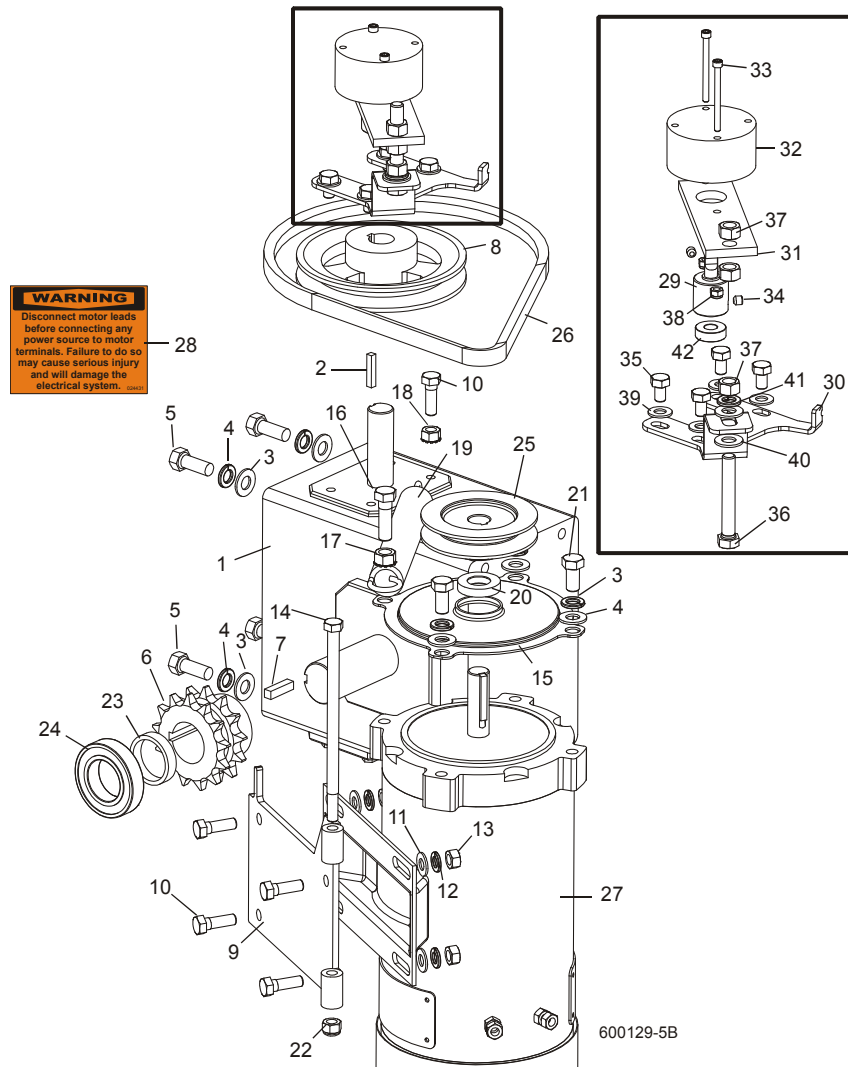

REF	DESCRIPTION (◆ Indicates Parts Available In Assemblies Only)	PART #	QTY.
1	GEAR BOX, B226-60-2-1L	034908	1
2	KEY, 3/16" SQUARE X 1" LONG	S31027	1
3	WASHER, 3/8" SAE FLAT	F05011-3	7
4	WASHER, 3/8" SPLIT LOCK	F05011-4	7
5	BOLT, 3/8-16 X 1" HEX HEAD	F05007-7	4
6	SPROCKET, DOUBLE 50-13 X 1 1/4"	036008	1
7	KEY, 1/4" SQUARE X 1" LONG	S21486	1
8	PULLEY, AK51 X 3/4" BORE	015256	1
9	BRACKET WELDMENT, UP/DOWN MOTOR MOUNT	015198	1
10	BOLT, 5/16-18 X 1" HEX HEAD	F05006-1	5
11	WASHER, 5/16" SAE FLAT	F05011-17	4



Up/Down System

Up/Down Drive Assembly

12	WASHER, 5/16" SPLIT LOCK	F05011-13	4	
13	NUT, 5/16-18 HEX	F05010-17	4	
14	BOLT, 5/16-18 X 6" HEX HEAD GRADE 5	F05006-73	1	
15	COVER, UP/DOWN MOTOR	034475	1	
16	BOLT, 3/8-16 X 1 1/4" HEX HEAD GRADE 5	F05007-123	1	
17	NUT, 3/8-16 HEX SELF-LOCKING	F05010-19	1	
18	NUT, 5/16-18 HEX SELF-LOCKING	F05010-20	1	
19	SPRING, 1" OD X 7" LONG X .148 WIRE EXTENSION	019303	1	
20	SEAL, CR6315	034501	1	
21	BOLT, 3/8-16 X 3/4" HEX HEAD	F05007-27	3	
22	NUT, 5/16-18 NYLON LOCK	F05010-58	1	
23	SPACER, UP/DOWN SPROCKET	036016	1	
24	BEARING, R20-2RS	036007	1	
25	PULLEY, AK20 X 5/8" BORE (ALL AC)	036179	1	
	PULLEY, AK34 X 5/8" BORE (DC WITH UP/DOWN ASSIST)	036675	1	
26	BELT, 4L300 (ALL AC)	021183	1	
	BELT, AX30 (DC WITH UP/DOWN ASSIST)	036682	1	
27	MOTOR, 1HP 12VDC (DC ONLY)	053682	1	
	Brush Kit, Leeson 1HP Motor	053682-BK	1	
	MOTOR, 1HP 230/460VAC 3P 1725RPM (AC ONLY)	050290	1	
28	DECAL, DISCONNECT MOTOR LEADS WARNING (DC ONLY)	024431	1	
	OIL, 8 OZ. MOBIL SHC634 BOTTLED SYNTHETIC GEAR	L04869-4 ¹	1	
	BRAKE ASSEMBLY, LT70 UP/DOWN RETRO (DC ONLY)	062566 ²	1	
29	Shaft, Up/Down Brake	062511	1	
30	Plate, LT70 Up/Dn Brake Mount	062512	1	
31	Plate, Brake Mount	062513	1	
	Brake Assembly, LT40/50/70 Up/Down Replacement	065907	1	
32	Brake, Klauber Gearmotor #K01134D300	069519	1	◆
	Terminal, 3/16" 18-22 Ga Quick Male	F05708-26	2	
33	Bolt, #8-32 x 2" Socket Head Stainless Steel	F05004-273	2	
34	Screw, 1/4-20 x 1/4" Cup Point Socket Set	F05005-131	2	
35	Bolt, 5/16-18 x 1/2" Hex Head Grade 5	F05006-15	2	
36	Bolt, 3/8-16 x 2 1/2" Hex Head Full Thread	F05007-157	1	
37	Nut, 3/8-16 Hex	F05010-1	3	
38	Nut, #8-32 Hex Nylon Lock	F05010-169	2	
39	Washer, 5/16" SAE Flat	F05011-17	4	
40	Washer, 3/8" SAE Flat	F05011-3	2	
41	Washer, 3/8" Split Lock	F05011-4	1	
42	Bearing, R6-2NSL SRI-2 ABEC-1	P10688	1	
	Diode OR Assembly, Up/Down Brake LT70	069678-FR	1	
	Instruction Sheet, LT70 DC Up/Down Brake Retro	062566-1717	1	

¹ 40 oz. required for complete oil replacement.

² Brake added Rev. B4.03 to prevent saw head from drifting during sawing.

9.5 Up/Down Assist Assembly (DC Only)

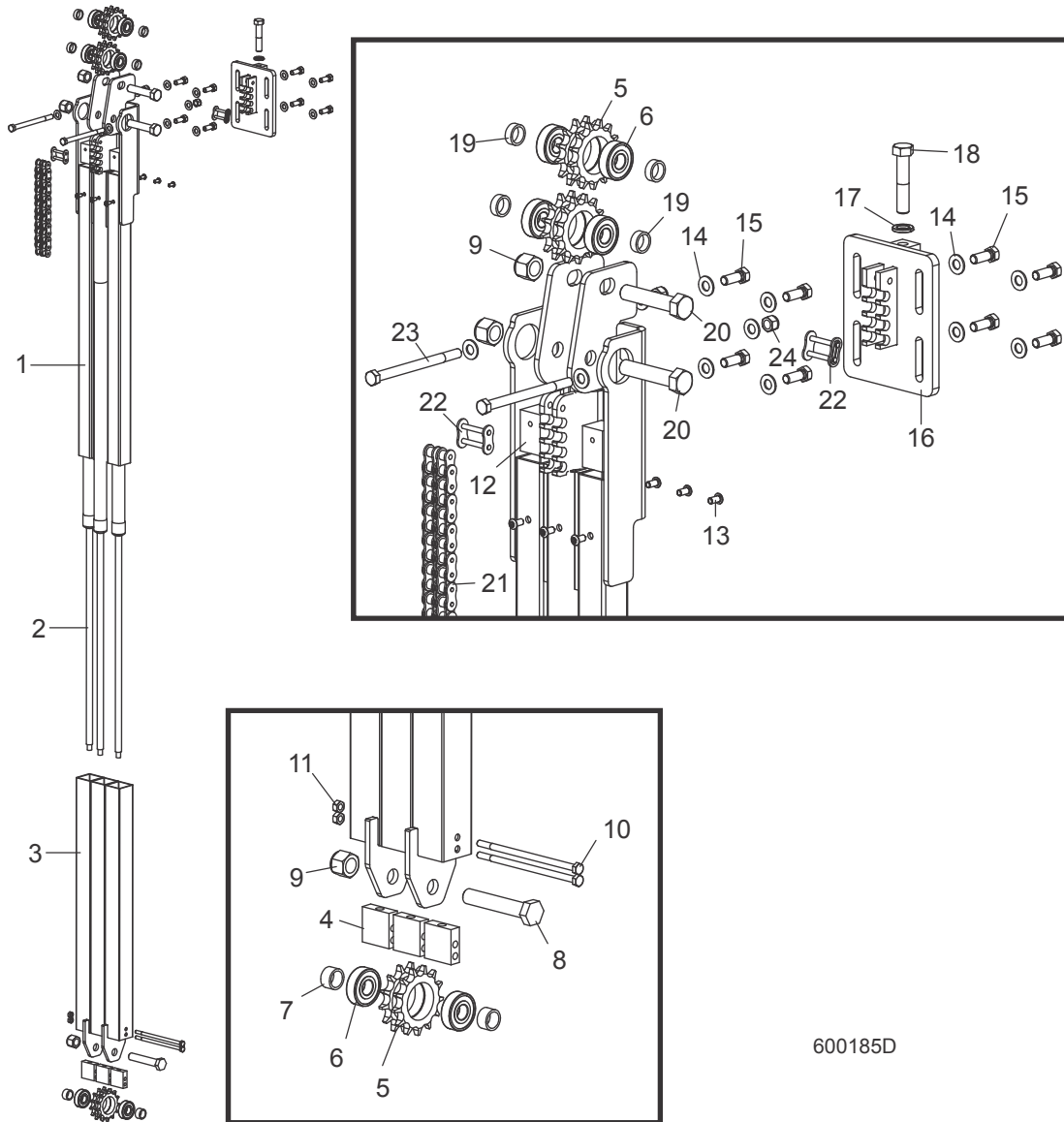

600185D

REF	DESCRIPTION (◆ Indicates Parts Available In Assemblies Only)	PART #	QTY.	
	ASSIST ASSEMBLY, LT70 UP/DOWN	047753	1	
1	Tube Weldment, Upper Assist	047754	1	
2	Spring Assembly, 562 Lb Gas w/Wiper	010032 ¹	3	
	Spring, LT70 562lbs Gas LT70	010026	1	◆
	Wiper, .542" Gas Spring Rubber	038628	1	
3	Tube Weldment, Lower Assist	047755	1	
4	Block, Spring Assist Mount LT70	079150 ¹	3	
	Sprocket Assembly, #50-2 Idler	016019	3	

9 Up/Down System

5	Sprocket, D50B13 Modified	015202	1	
6	Bearing, 5/8" ID x 1.7548" OD x .4724"	P06030-1	1	
7	Spacer, 50-2 Idler	016018	2	
8	Bolt, 5/8-11 x 3 1/2" Hex Head Grade 5	F05009-93	1	
9	Nut, 5/8-11 Hex Nylon Lock	F05010-34	3	
10	Bolt, 1/4-20 x 5 1/2" Hex Head Grade 5	F05005-82	2	
11	Nut, 1/4-20 Hex Lock	F05010-21	2	
12	Block, Upper Gas Spring Mount	047922	3	
13	Screw, 1/4-20 x 1/2" Button Socket Head	F05005-59	6	
14	Washer, 3/8" SAE Flat	F05011-3	12	
15	Bolt, 3/8-16 x 1" Hex Head Grade 5	F05007-87	8	
16	Mount Weldment, Up/Down Assist	047924	1	
17	Washer, 1/2" Split Lock	F05011-9	1	
18	Bolt, 1/2-13 x 2 1/2" Hex Head Grade 5	F05008-74	1	
19	Spacer, 50-2 Idler	047921	4	
20	Bolt, 5/8-11 x 3" Hex Head Grade 5	F05009-37	2	
21	Chain, #50-2 Up/Down Assist	036680	1	
22	Link, #50-2 Master	015258	2	
23	Bolt, 3/8-16x5" Hex Head	F05007-5	2	
24	Nut, 3/8-16 Hex Nyloc	F05010-10	2	

¹ 010032 replaced 065410 Spring Assembly and 079150 replaced 048410 Mount Block to improve durability (Rev. B6.10). Order upgrade kit 079157 including (3) 010032 Spring Assemblies and (3) 079150 Mount Blocks when servicing sawmills prior to Rev. B6.10. Previously, 065410 Spring Assembly was created to include 047737 Gas Spring and 038628 Gas Spring Rubber Wiper epoxyed together (6/11).

SECTION 10 FEED SYSTEM & TRACK ROLLERS

10.1 Upper Track Rollers And Wipers

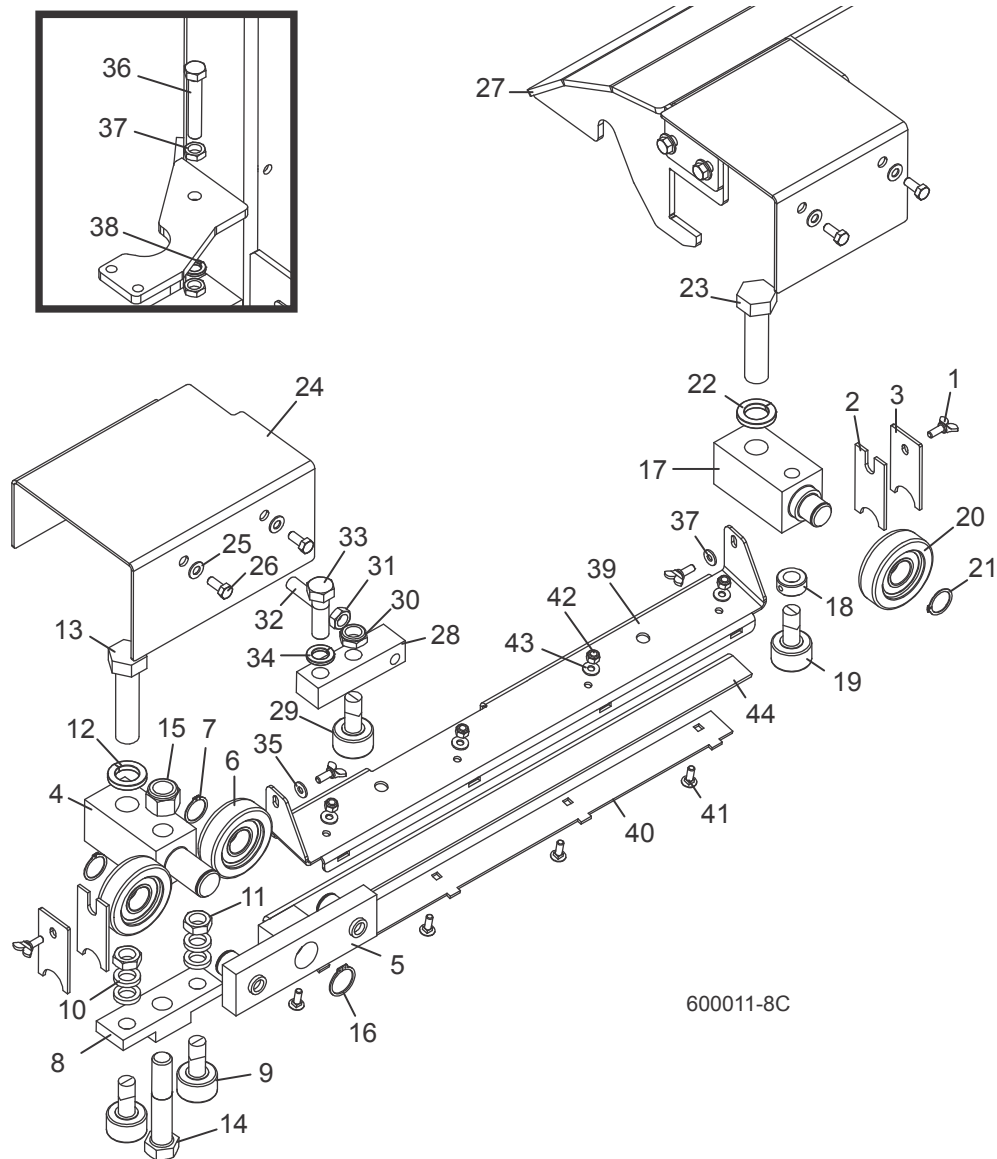

REF	DESCRIPTION (◆ Indicates Parts Available In Assemblies Only)	PART #	QTY.
1	BOLT, 1/4-20 X 5/8" WING	F05005-64	4
2	WIPER, TOP RAIL	M04113	2
3	PLATE, TRACK WIPER	034229	2
	ROLLER ASSEMBLY, FRONT UPPER TRACK	042506	1
4	Block, Upper Roller Mount	042505	1
5	Block Assembly, Upper Roller	042507	1

10

Feed System & Track Rollers

Upper Track Rollers And Wipers

6	Bearing, MG305DDA	023857	2	
7	Ring, 1" Outer Retaining	F04254-15	2	
8	Block, Track Bearing Mount	042500	1	
9	Bearing, 1 1/2" Track	012797	2	
10	Spacer, 41/64" x 1" x 3/16"	S12480	4	
11	Nut, 5/8-18 Hex Jam	F05010-11	2	
12	Washer, 7/8" Split Lock	F05011-46	1	
13	Bolt, 7/8-14 x 3 1/2" Hex Head Grade 5	F05014-1	1	
14	Bolt, 3/4-10 x 4" Hex Head Grade 5	F05013-3	1	
15	Nut, 3/4-10 Hex Nylon Lock	F05010-103	1	
16	Ring, 1 1/8" Outer Retaining	F04254-36	1	
	ROLLER ASSEMBLY, REAR UPPER TRACK	034231	1	
17	Block, Upper Roller Mount	034230	1	
18	Collar, 5/8" ID Lock	P05035	1	
19	Bearing, 1 1/2" Track	012797	1	
20	Bearing, MG305DDA	023857	1	
21	Ring, 1" Outer Retaining	F04254-15	1	
22	Washer, 7/8" Split Lock	F05011-46	1	
23	Bolt, 7/8-14 x 3 1/2" Hex Head Grade 5	F05014-1	1	
24	COVER, FRONT UPPER TRACK ROLLER	033942	1	
25	WASHER, 5/16" SPLIT LOCK	F05011-17	4	
26	BOLT, 5/16-18 X 3/4" HEX HEAD	F05006-102	4	
27	POWER FEED MOTOR GUARD PARTS (See Section 10.2)	See Parts	1	
28	BLOCK, MIDDLE UPPER TRACK ROLLER MOUNT	017884	1	
29	BEARING, 1 1/2" TRACK	012797	1	
30	NUT, 5/8-18 NYLON HEX JAM	F05010-101	1	
31	NUT, 1/2-20 HEX JAM	F05010-16	1	
32	SCREW, 1/2-20 X 1 3/4" FLAT POINT SET	F05008-112	1	
33	BOLT, 5/8-11 X 2" HEX HEAD	F05009-2	1	
34	WASHER, 5/8" SPLIT LOCK GRADE 8	F05011-118	1	
35	WASHER, 1/4" SAE FLAT	F05011-11	2	
36	BOLT, 1/2-13 X 3 FULL THREAD HEX HEAD TAP	F05008-7	1	
37	NUT, 1/2-13 JAM	F05010-31	2	
38	WASHER, 1/2 SPLIT LOCK	F05011-9	1	
	COVER ASSEMBLY, LT28/35/70 TRACK	110614	1	
39	Cover, Mid Track, LT28, LT35, LT70	110610	1	
40	Retainer, Felt Oiler	110611	1	
41	Bolt, 1/4-20x3/4 Carriage	F05005-113	4	
42	Nut, 1/4-20 Nylock	F05010-69	4	
43	Washer, 1/4 SAE Flat	F05011-11	4	
44	Felt, Middle Track Oiler LT40/50/70	S09915	1	

10.2 Power Feed Assembly

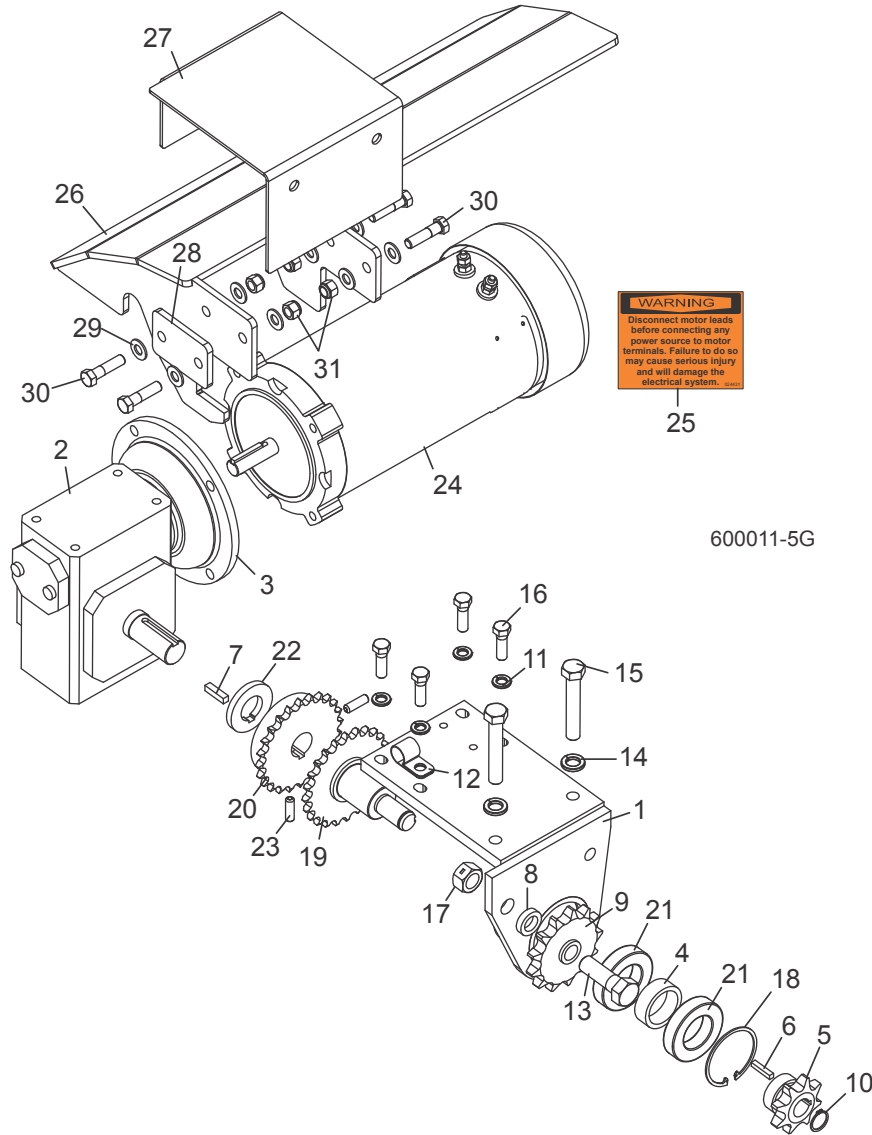

REF	DESCRIPTION (◆ Indicates Parts Available In Assemblies Only)	PART #	QTY.
	POWER FEED ASSEMBLY	034860 ¹	1
1	Bracket Weldment, Power Feed Mount	034850	1
2	Gearbox, Power Feed	034843	1
3	Plate, Gearbox Adaptor	057444	1
4	Spacer, 1.185 x 1.5 x .428	034856	1
5	Sprocket, 60B8 x 3/4"	034223	1
6	Key, 3/16" Square x 1" Long	S31027	1
7	Key, 1/4" Square x 1" Long	S21486	1
8	Spacer, .63 x 1.00 x .226	017719	1

10

Feed System & Track Rollers

Power Feed Assembly

9	Sprocket, 60BB13H x 5/8" Idler	034224	1	
10	Ring, 3/4" 5100-75 Ext Retaining	F04254-46	1	
11	Washer, 3/8" Split Lock	F05011-4	4	
12	Clamp, 5/8" EMT Coated	010748	1	
13	Bolt, 5/8-11 x 2" Hex Head Gr2	F05009-2	1	
14	Washer, 1/2" Split Lock	F05011-9	2	
15	Bolt, 1/2-20 x 3" Hex Head Full Thread	F05008-62	2	
16	Bolt, 3/8-16 x 1 1/4" Hex Head Full Thread Grade 5	F05007-123	4	
17	Nut, 5/8-11 Swaged Hex	F05010-4	1	
18	Ring, 62mm IR	F04254-12	1	
19	Shaft Weldment, LT60/70 Power Feed	074702	1	
20	Sprocket, 40B24 x1	034851	1	
21	Bearing, 6007-2RS 35x62x14	034852	2	
22	Spacer, 1.03" ID x 2" OD x 3/8" Keyed	034857	1	
23	Screw, 5/16-18x1 SH Set, Cup Point	F05006-165	2	
	Chain, Double #40 x 11 1/2"	036196	1	
	Link, #40 x 2 Connecting	017724	1	
	Oil, 8 Oz. Mobil SHC634 Bottled Synthetic Gear	L04869-4 ²	1	
24	MOTOR, 1HP 12VDC POWER FEED (DC ONLY)	053679 ³	1	
	Guard, Motor Fan	047998	1	
	Hub, Motor Fan Extension	047999	1	
	Key, 3/16" Square x 1" Long	S31027	1	
	Brush Kit, 3/4HP 12V DC Leeson Motor	024167	1	
	MOTOR, 1.5HP 230/460VAC 3P 1725RPM POWER FEED (AC ONLY)	050291	1	
25	DECAL, DISCONNECT MOTOR LEADS WARNING (DC ONLY)	024431	1	
	GUARD ASSEMBLY, LT70 FEED MOTOR (OPTIONAL)	038878-A	1	
26	Guard Weldment, LT70 Feed Motor	038877	1	
27	Guard, Top Track Roller	038876	1	
28	Plate, LT70 Power Feed Guard Spacer	038874	1	
29	Washer, 3/8" SAE Flat	F05011-3	8	
30	Bolt, 3/8-16 x 1 1/2" Hex Head Grade 5	F05007-78	4	
31	Nut, 3/8-16 Hex Nylon Lock	F05010-10	4	

¹ Power feed assembly modified to improve durability (6/15). Changes include adding 034223 Sprocket, 074702 Shaft Weldment, F04254-46 Ring and S31027 Key (included in 074747 Power Feed Assembly); removing 017723 Sprocket, 034855 Shaft Weldment, F05007-7 Bolt, S02779 Washer, S03060 Key; changing quantity of F05011-4 Washer to 4.

² 12 - 15 oz. required for complete oil replacement.

³ Replaces 3/4HP 12VDC Power Feed Motor 024169 (Rev. B4.11). Power Feed Motor 024169 included Brush Kit 024167, Fan 016087, Fan Guard 061146 and 3/16" Square x 1" Long Key S31027.

10.3 Feed Chain/Stop

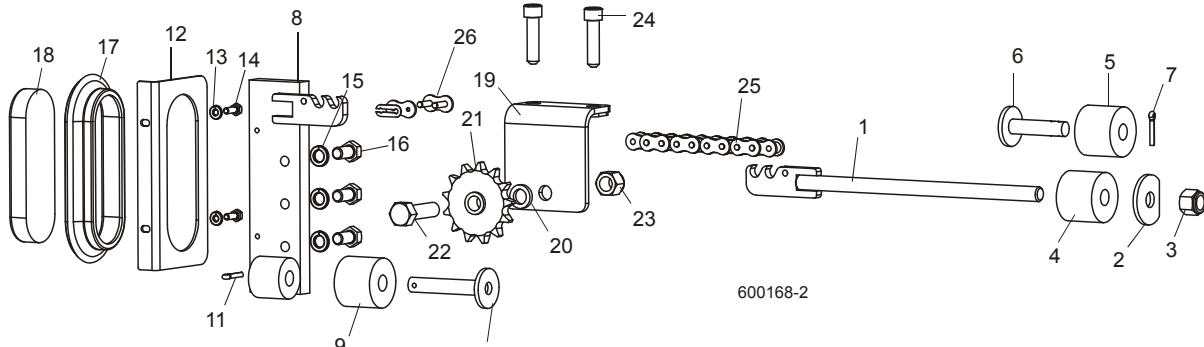

REF	DESCRIPTION (◆ Indicates Parts Available In Assemblies Only)	PART #	QTY.
	STOP ASSEMBLY, FRONT POWER FEED	034556	1
1	Tensioner Weldment, Power Feed Chain	034421	1
2	Washer, 21/32" x 2 1/4" x 3/16" D	017838	1
3	Nut, 5/8-11 Nylon Lock	F05010-34	1
4	Stop, Rubber Carriage	P12165	1
	Stop Kit, Rubber Carriage	K09630	1
5	Stop, Rubber Carriage	P12165	1
6	Pin, Rubber Carriage Stop	W09293	1
7	Pin, 3/16" X 1" Cotter	F05012-21	1
	STOP ASSEMBLY, REAR POWER FEED W/LIGHT	006721	1
8	Stop Weldment, Rear Power Feed	036493	1
9	Stop, Rubber Carriage	P12165	1
10	Pin, Rear Carriage Stop	034423	1
11	Pin, 3/16" X 1" Cotter	F05012-21	1
12	Plate, Bed Tube End	057822	1
13	Washer, 1/4" Split Lock	F05011-14	2
14	Bolt, 1/4-20 x 3/4" Hex Head	F05005-1	2
15	Washer, 1/2" Split Lock	F05011-9	3
16	Bolt, 1/2-13 x 1" Hex Head Grade 8	F05008-128	3
17	Grommet, 6 1/2" Light Mounting	006688	1
18	Light, 8 Diode LED Tail	006391	1
	IDLER ASSEMBLY, #60 POWER FEED CHAIN	034228	1
19	Plate Weldment, Power Feed Idler	034227	1
20	Spacer, 41/64" x 1" x 3/16"	S12480	1
21	Sprocket, 60BB13H x 5/8" Idler	034224	1
22	Bolt, 5/8-18 x 2 1/4" Hex Head Grade 5	F05009-80	1
23	Nut, 5/8-18 Nylon Lock	F05010-71	1
24	Bolt, 1/2-13 x 2" Socket Head	F05008-133	2
25	CHAIN, #60 X 286 1/2" POWER FEED	017842	1
26	LINK, #60 MASTER	042398	2

10.4 Lower Track Rollers

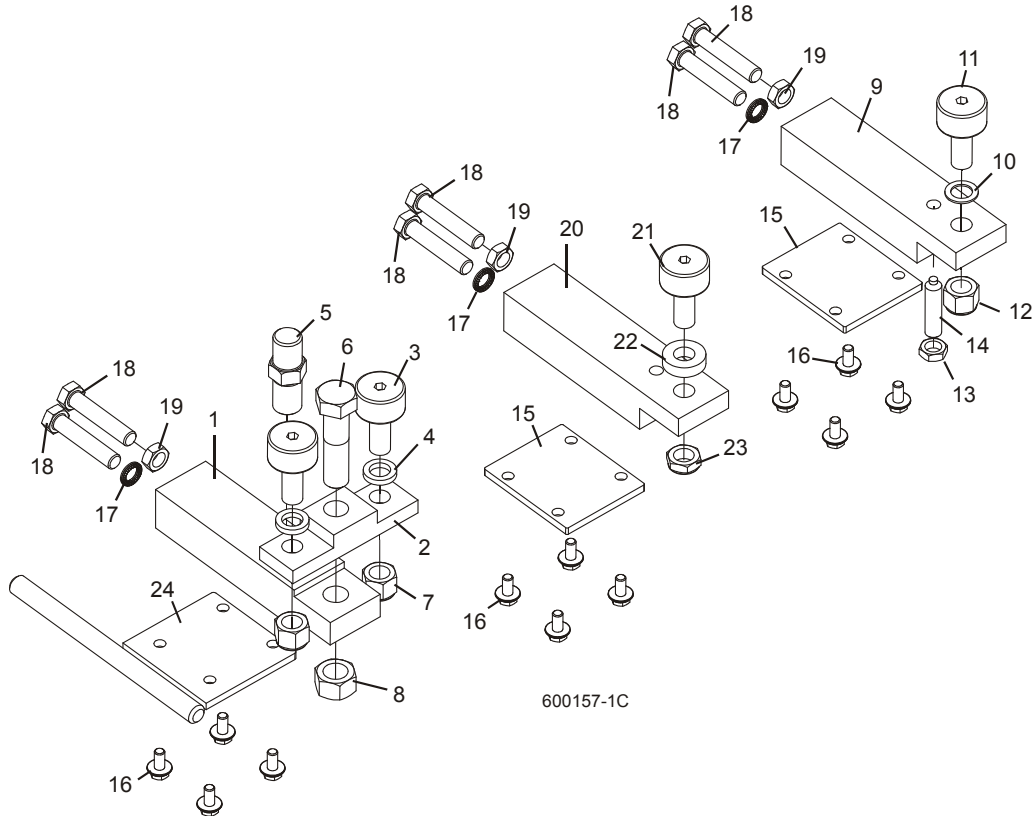

REF	DESCRIPTION (◆ Indicates Parts Available In Assemblies Only)	PART #	QTY.
	ROLLER ASSEMBLY, FRONT LOWER TRACK	036344	1
1	Block, Front Lower Track Roller Mount	036325	1
2	Block, Track Bearing Mount	042500	1
3	Bearing, 1 1/2" Track Roller	012797	2
4	Spacer, 41/64" x 1" x 3/16"	S12480	2
5	Pin, Safety Lock (Threaded)	036324	1
6	Bolt, 3/4-10 x 3" Hex Head Grade 5	F05013-5	1
7	Nut, 5/8-18 Hex Nylon Lock	F05010-101	2
8	Nut, 3/4-10 Hex Lock	F05010-80	1
	ROLLER ASSEMBLY, REAR LOWER TRACK	034232	1
9	Block, Rear Lower Track Roller Mount	034234	1
10	Shim, 5/8" x 1" x 1/16"	016510	1
11	Bearing, 1 1/2" Track Roller	012797	1
12	Nut, 5/8-18 Hex Jam	F05010-11	1
13	Nut, 1/2-13 Hex Jam	F05010-31	1
14	Screw, 1/2-13 x 2" Brass Tip Set	F05008-137	1
15	PLATE, LOWER TRACK ROLLER RETAINER	033880 ¹	2

16	BOLT, 5/16-18 X 3/4" HEX HEAD W/FLAT & LOCK WASHER	F05006-101 ²	12	
17	WASHER, 1/2" NORD-LOCK	F05011-125 ²	3	
18	BOLT, 1/2-20 X 2 1/2" HEX HEAD FULL THREAD GRADE 5	F05008-135	6	
19	NUT, 1/2-20 HEX JAM	F05010-16	3	
	ROLLER ASSEMBLY, MIDDLE LOWER TRACK	017887	1	
20	Block, Lower Track Roller Mount	034234	1	
21	Bearing, 1 1/2" Track Roller	012797	1	
22	Spacer	034674	1	
23	Nut, 5/8-18 Nylon Lock Jam	F05010-101	1	
24	PLATE WELDMENT, FRONT LOWER TRACK ROLLER W/DEFLECTOR	036473 ¹	1	

¹ One Retainer Plate 033880 replaced with Deflector Weldment 036473 at front track roller to prevent assembly from catching on remote cable chain (Rev. A3.02).

² Bolt with lock and flat washer F05006-101 replaces 5/16" Split Lock Washer F05011-13 and Hex Head Bolt F05006-102, Nord-Lock Washer F05011-125 replaces F05011-9 1/2" Split Lock Washer supplied prior to Rev. B4.00. Hardware changes with mast side plate revision provides increased fastener durability.

11

Bed Frame Assembly Bed Rail Assembly, Front And Rear

SECTION 11 BED FRAME ASSEMBLY

11.1 Bed Rail Assembly, Front And Rear

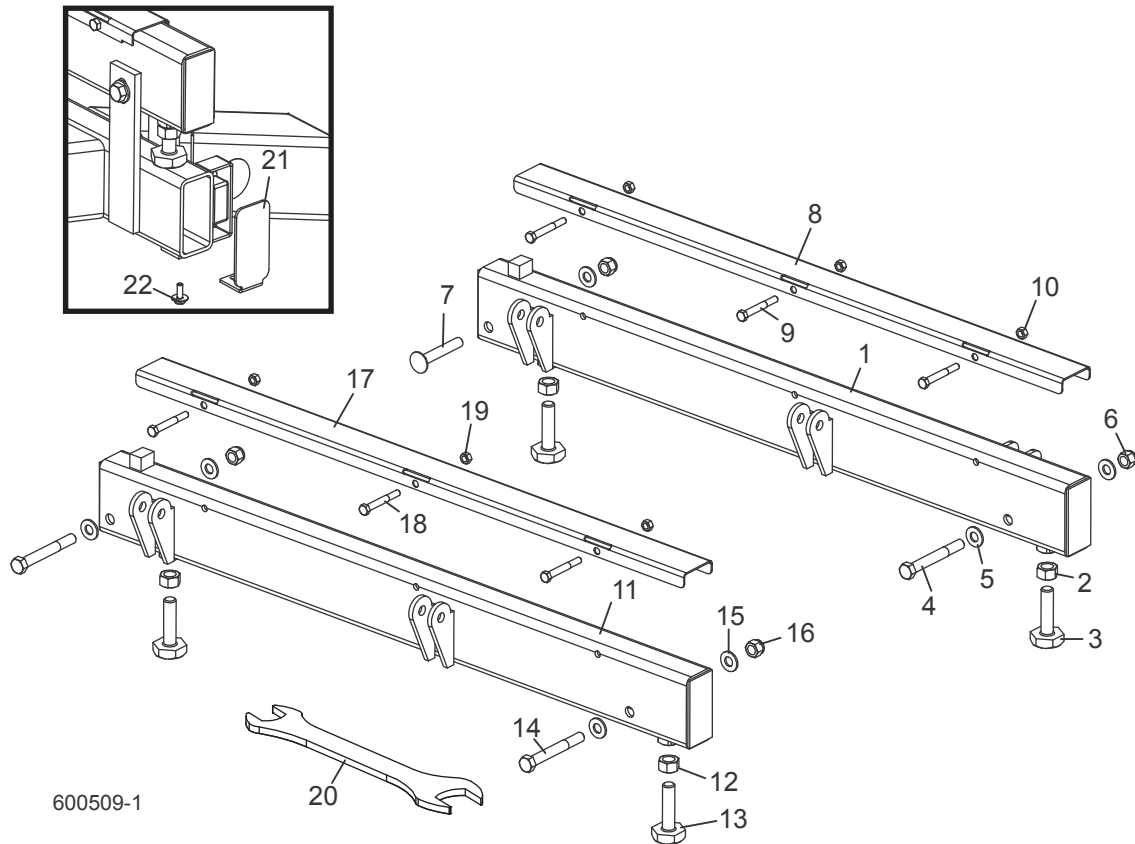

REF	DESCRIPTION (◆ Indicates Parts Available In Assemblies Only)	PART #	QTY.
	BED RAIL ASSEMBLY, REAR PAINTED (LT60/70 BED 4)	034551	1
1	Tube Weldment, Bed Rail 4	034547	1
2	Nut, 5/8-11 Hex	F05010-5	2
3	Bolt, Bed Rail Adjustment	S13006	2
4	Bolt, 1/2-13 X 4" Hex Head	F05008-78	1
5	Washer, 1/2" SAE Flat	F05011-2	3
6	Nut, 1/2-13 Nylon Lock	F05010-8	2
7	Bolt, 1/2-13 x 3 1/2" Carriage	F05008-94	1
	Cover Kit, Front/Rear Bed Rail SS	079144	1
8	Cover, Stainless Steel Bed Rail	016898	1
9	Bolt, 5/16-18 X 2 1/2" Hex Head	F05006-10	3
10	Nut, 5/16-18 Hex Lock	F05010-6	3
	Hydraulic Toe Board Parts (See Section 12.15)		
	BED RAIL ASSEMBLY, FRONT PAINTED (LT60/70 BED 1)	034548	1

Bed Frame Assembly

Bed Rail Assembly, Front And Rear

11

11	Tube Weldment, Bed Rail 1	034544	1	
12	Nut, 5/8-11 Hex	F05010-5	2	
13	Bolt, Bed Rail Adjustment	S13006	2	
14	Bolt, 1/2-13 X 4" Hex Head	F05008-78	2	
15	Washer, 1/2" SAE Flat	F05011-2	4	
16	Nut, 1/2-13 Nylon Lock	F05010-8	2	
	Cover Kit, Front/Rear Bed Rail SS	079144	1	
17	Cover, Stainless Steel Bed Rail	016898	1	
18	Bolt, 5/16-18 X 2 1/2" Hex Head	F05006-10	3	
19	Nut, 5/16-18 Hex Lock	F05010-6	3	
	Hydraulic Toe Board Parts (See Section 12.15)			
20	WRENCH, BED RAIL ADJUSTMENT	015970	1	
21	CAP, BED RAIL REMOVABLE END	038843	2	
22	BOLT, 1/4-20 X 3/4" W/CONICAL WASHER HEAD	F05005-134	2	

11

Bed Frame Assembly Bed Rail Assembly, Middle Front

11.2 Bed Rail Assembly, Middle Front

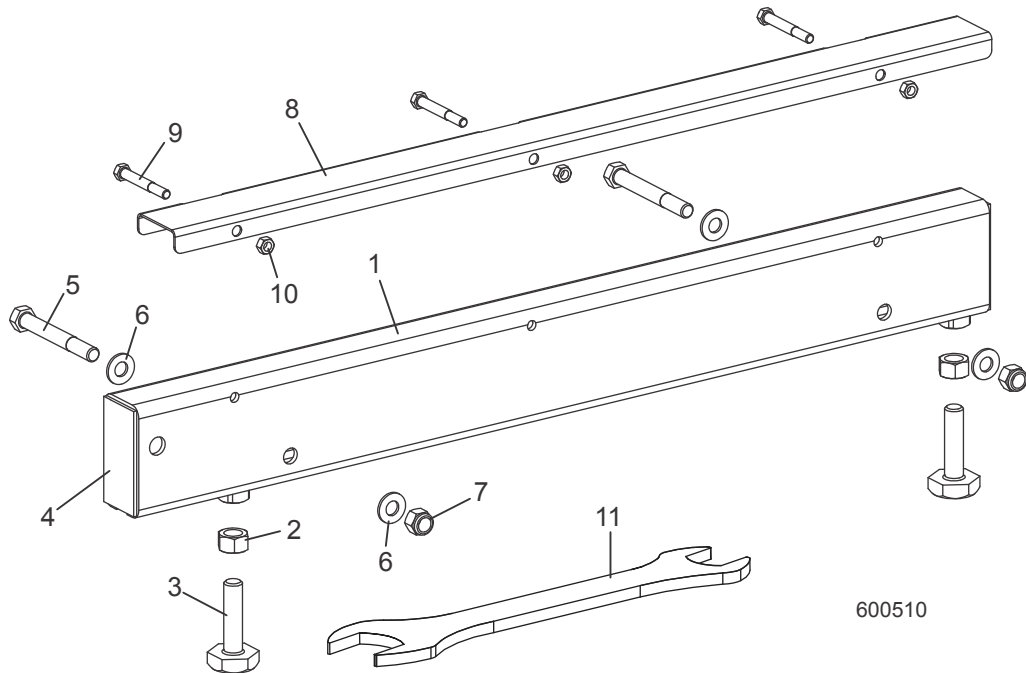

REF	DESCRIPTION (◆ Indicates Parts Available In Assemblies Only)	PART #	QTY.	
	BED RAIL ASSEMBLY, FRONT MIDDLE (LT60/70 BED 2)	034549	1	
1	Bed Rail Tube, Short	034545	1	◆
2	Nut, 5/8-11 Hex	F05010-5	2	
3	Bolt, Bed Rail Adjustment	S13006	2	
4	Plate, Bed Rail End Cap	S04058	2	◆
5	Bolt, 1/2-13 X 4" Hex Head Grade 5	F05008-78	2	
6	Washer, 1/2" SAE Flat	F05011-2	4	
7	Nut, 1/2-13 Nylon Lock	F05010-8	2	
	Cover Assembly, Stainless Steel Bed Rail (Long)	A09956	1	
8	Cover, Stainless Steel Bed Rail	S09944	1	◆
9	Bolt, 5/16-18 X 2 1/2" Hex Head	F05006-10	3	
10	Nut, 5/16-18 Hex Lock	F05010-6	3	
11	WRENCH, BED RAIL ADJUSTMENT	015970	1	

11.3 Bed Rail Assembly, Middle Rear

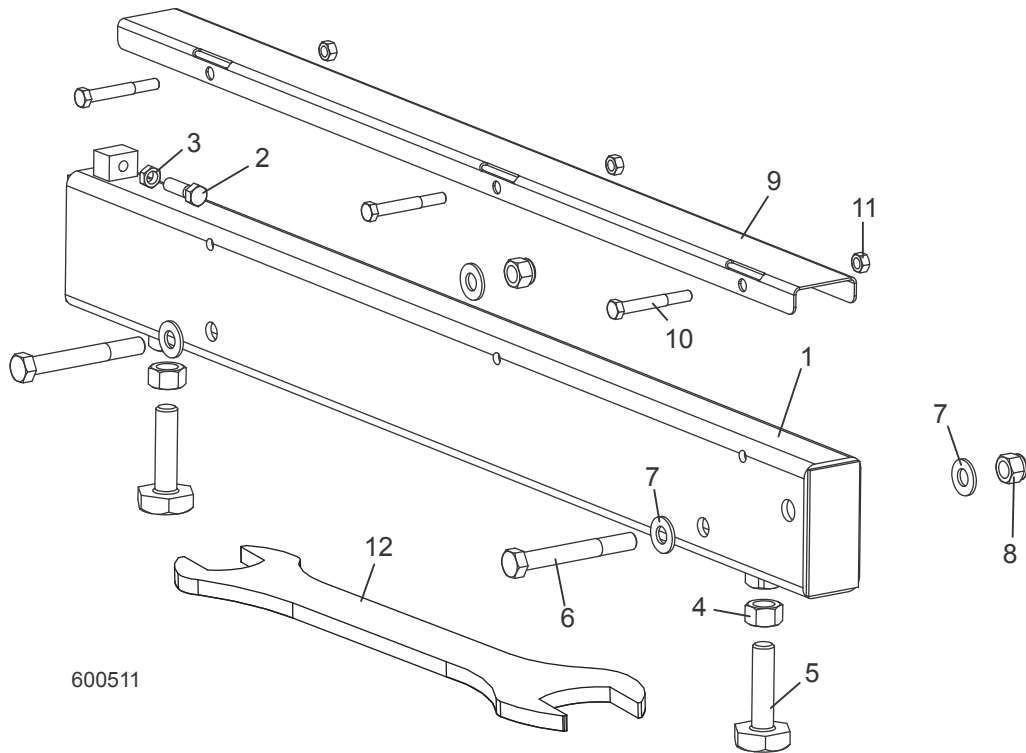

REF	DESCRIPTION (◆ Indicates Parts Available In Assemblies Only)	PART #	QTY.	
	BED RAIL ASSEMBLY, REAR MIDDLE PAINTED (LT60/70 BED 3)	034550	1	
1	Tube Weldment, Bed Rail 3	034546	1	
2	Screw, 3/8-16x1 1/4 HHC	F05007-2	1	
3	Nut, 3/8-16 Hex Jam	F05010-29	1	
4	Nut, 5/8-11 Hex	F05010-5	2	
5	Bolt, Bed Rail Adjustment	S13006	2	
6	Bolt, 1/2-13 X 4" Hex Head Grade 5	F05008-78	2	
7	Washer, 1/2" SAE Flat	F05011-2	4	
8	Nut, 1/2-13 Nylon Lock	F05010-8	2	
	Cover Assembly, Stainless Steel Bed Rail (Long)	A09956	1	
9	Cover, Stainless Steel Bed Rail	S09944	1	◆
10	Bolt, 5/16-18 X 2 1/2" Hex Head	F05006-10	3	
11	Nut, 5/16-18 Hex Lock	F05010-6	3	
12	WRENCH, BED RAIL ADJUSTMENT	015970	1	

11 Bed Frame Assembly

Leg Assembly (Stationary)

11.4 Leg Assembly (Stationary)

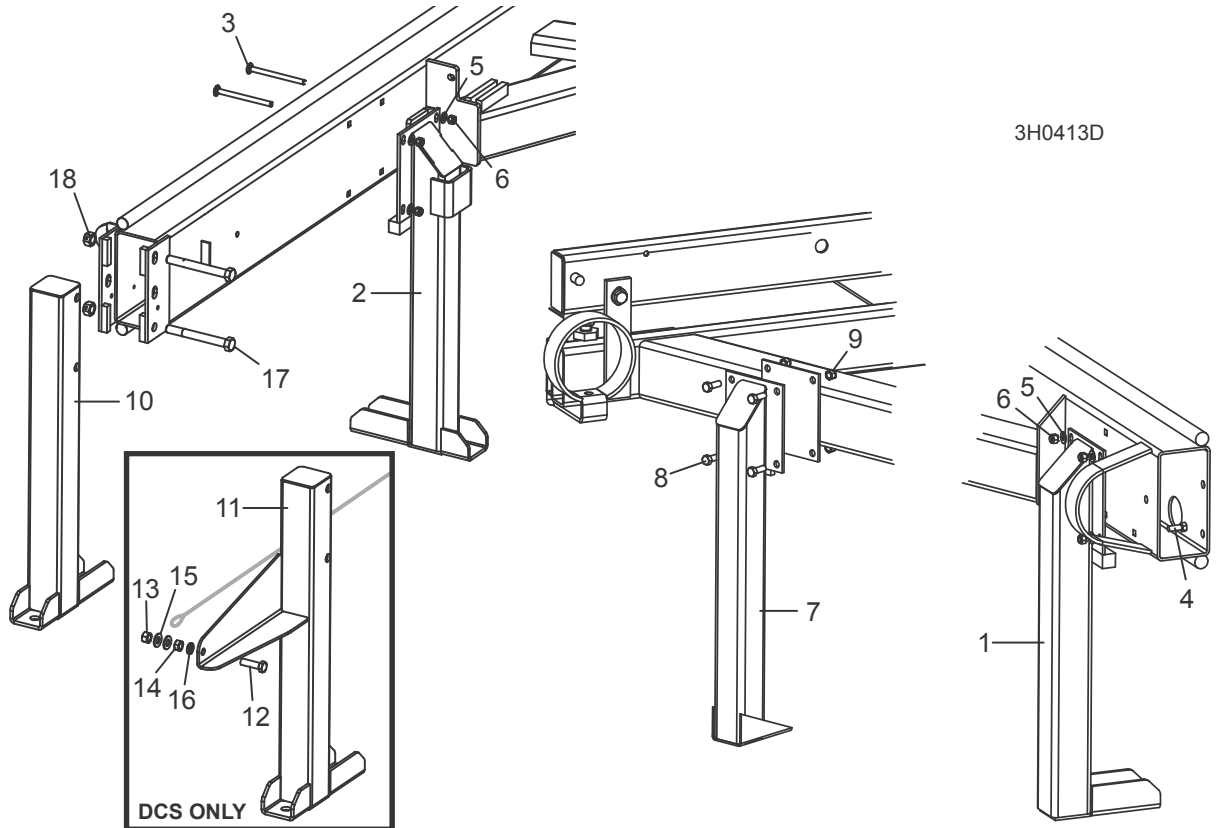

REF	DESCRIPTION (◆ Indicates Parts Available In Assemblies Only)	PART #	QTY.
	See Form #847 or diagram below for stationary sawmill foot anchor locations		
	See Form #359 for stationary sawmill w/bed extension foot anchor locations		
1	LEG, LONG STATIONARY (1 REQ'D FOR LT60HD; 3 REQ'D FOR LT70HD)	W09513	1/3
2	LEG, LONG STATIONARY W/BOARD RETURN TABLE BRACKET	015091	1
3	BOLT, 3/8-16 X 5" CARRIAGE HEAD	F05007-113	8/12
4	BOLT, 3/8-16 X 1 1/4" HEX HEAD (REQ'D FOR REAR LT70HD ONLY)	F05007-2	4
5	WASHER, 3/8" SAE FLAT	F05011-3	8/16
6	NUT, 3/8-16 HEX NYLON LOCK	F05010-10	8/16
7	LEG, SHORT STATIONARY	W09515	2
8	BOLT, 3/8-16 X 1 1/4" HEX HEAD	F05007-2	8
9	NUT, 3/8-16 HEX NYLON LOCK	F05010-10	8
10	LEG, FRONT STATIONARY (ALL EXCEPT LT70DCS)	W09517	1
	LEG ASSEMBLY, FESTOON FRONT STATIONARY (LT70DCS ONLY)	065937	1
11	Leg Weldment, Festoon Stationary Front	065935	1
12	Bolt, 1/2-13 x 1 3/4" Full Thread Hex Head Grade 5	F05008-88	1
13	Nut, 1/2-13 Swaged Hex	F05010-3	1
14	Nut, 1/2-13 Free Hex	F05010-35	1

15	Washer, 1/2" SAW Flat	F05011-2	2	
16	Washer, 1/2" Split Lock	F05011-9	1	
17	BOLT, 5/8-11 X 5 1/2" HEX HEAD GRADE 5 (ALL EXCEPT LT70DCS)	F05009-11	2	
18	NUT, 5/8-11 HEX LOCK (ALL EXCEPT LT70DCS)	F05010-4	2	

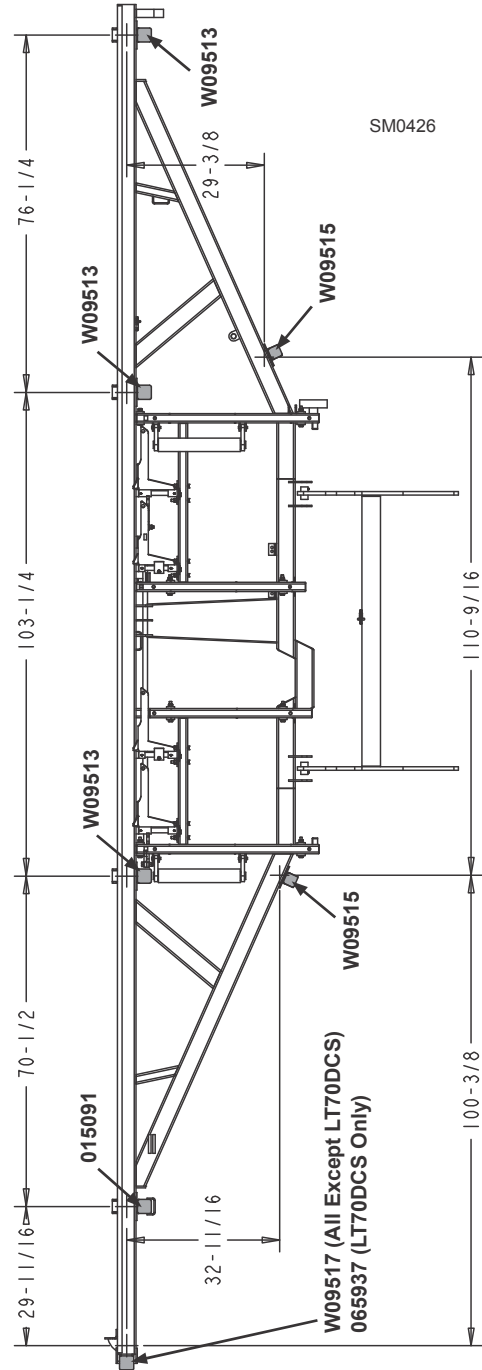
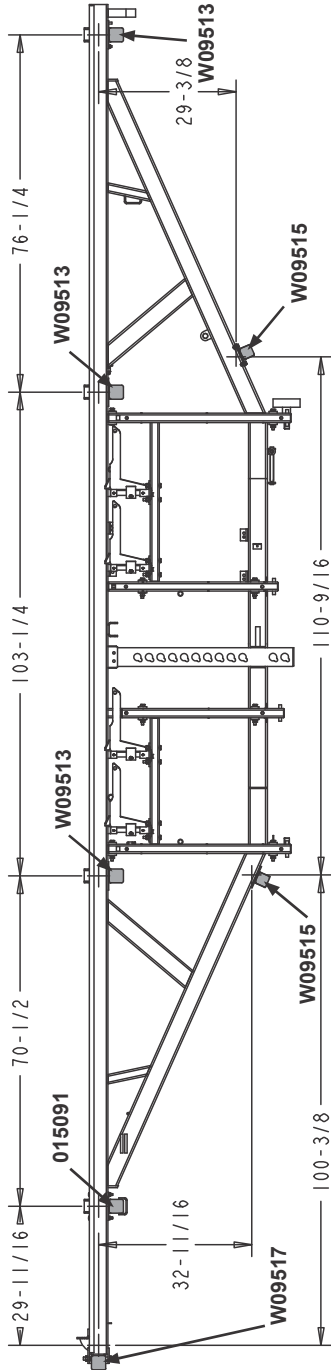

11

Bed Frame Assembly Board Return Table Assembly

11.5 Board Return Table Assembly

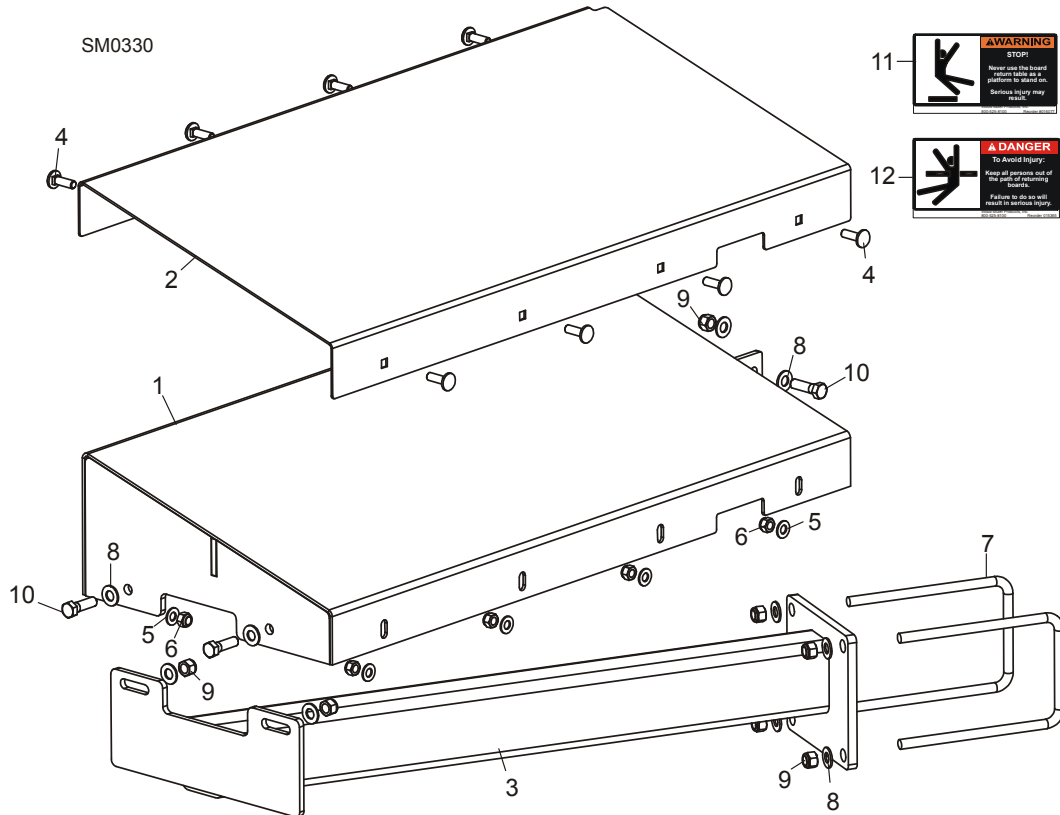

REF	DESCRIPTION (◆ Indicates Parts Available In Assemblies Only)	PART #	QTY.
	TABLE ASSEMBLY, BOARD RETURN (LT70)	003264	1
	TABLE ASSEMBLY, BOARD RETURN (LT60)	003270	1
1	Table Weldment, Board Return	055515	1
2	Cover, Board Return Table	003259	1
3	Mount Weldment, Board Return Table (LT70)	055533	1
	Mount Weldment, Board Return Table (LT60)	038992	1
4	Bolt, 5/16-18 x 1" Carriage Head	F05006-9	8
5	Washer, 5/16" SAE Flat	F05011-17	8
6	Nut, 5/16-18 Nylon Lock	F05010-58	8
7	Bolt, 3/8-16 x 4" x 5" 'U'	003207	2
8	Washer, 3/8" SAE Flat	F05011-3	10
9	Nut, 3/8-16 Hex Nylon Lock	F05010-10	7
10	Bolt, 3/8-16 x 1 1/4" Hex Head Grade 5	F05007-123	3
11	Decal, Board Return Table Warning	016077	1
12	Decal, Board Return Danger	015365	1

11.6 Pivot Bed Rail Assembly

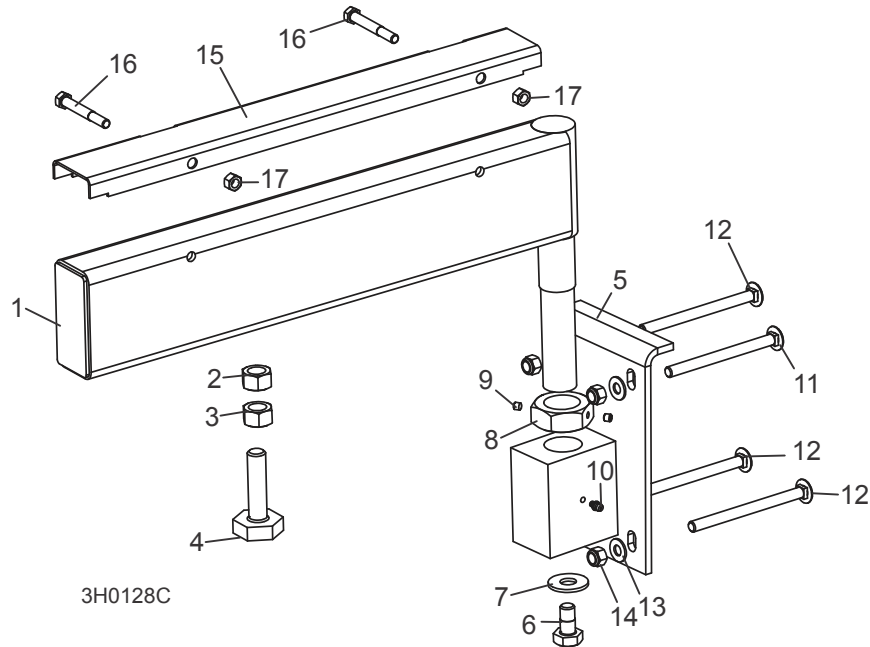

REF	DESCRIPTION (◆ Indicates Parts Available In Assemblies Only)	PART #	QTY.	
	PIVOT BED RAIL ASSEMBLY (LT70HD)	A13015 ¹	1	
	PIVOT BED RAIL ASSEMBLY (LT60HD)	012993	2	
1	Pivot Bed Rail Weldment (LT70HD)	W13014	1	◆
	Pivot Bed Rail Weldment (LT60HD)	012992	1	◆
2	Nut, 5/8-11 Pilot Weld	F05010-84	2	
3	Nut, 5/8-11 Hex	F05010-5	2	
4	Bolt, Bed Rail Adjustment	S13006	2	
5	Bracket, Pivot Rail Mounting	W13090	1	
6	Bolt, 1/2-13 x 1" Hex Head Grade 2	F05008-50	1	
7	Washer, 9/16" SAE Flat	F05011-52	1	
8	Nut, Pivot Rail Adjustment	S13016	1	
9	Screw, 1/4-28 x 1/4" Brass Tip Set	F05005-42	2	
10	Fitting, 3/16" Grease	P04107	1	
11	BOLT, 3/8-16 X 4 3/4" CARRIAGE HEAD	F05007-114	2	
12	BOLT, 3/8-16 X 5" CARRIAGE HEAD	F05007-113	6	
13	WASHER, 3/8" SAE FLAT	F05011-3	8	
14	NUT, 3/8-16 NYLON LOCK	F05010-10	8	
	COVER KIT, PIVOT RAIL STAINLESS STEEL (LT70HD)	017710	2	
	COVER KIT, PIVOT RAIL STAINLESS STEEL (LT60HD)	015926	2	
15	Cover, Stainless Steel Pivot Bed Rail (LT70HD)	S13012	1	
	Cover, Stainless Steel Pivot Bed Rail (LT60HD)	012994	1	
16	Bolt, 5/16-18 X 2 1/2" Hex Head	F05006-10	2	

11

Bed Frame Assembly

Pivot Bed Rail Assembly

17	Nut, 5/16-18 Hex Lock	F05010-6	2	
	WRENCH, BED RAIL ADJUSTMENT (See Section 11.1)	015970	1	

¹ Replaced (1) A13015 Pivot Bed Rail Assembly at off load table end with (1) 076729 Taper Roller Pivot Assembly (LT70 Rev.B6.09/LT70Super Rev. A4.07).

11.7 Taper Roller Pivot Assembly

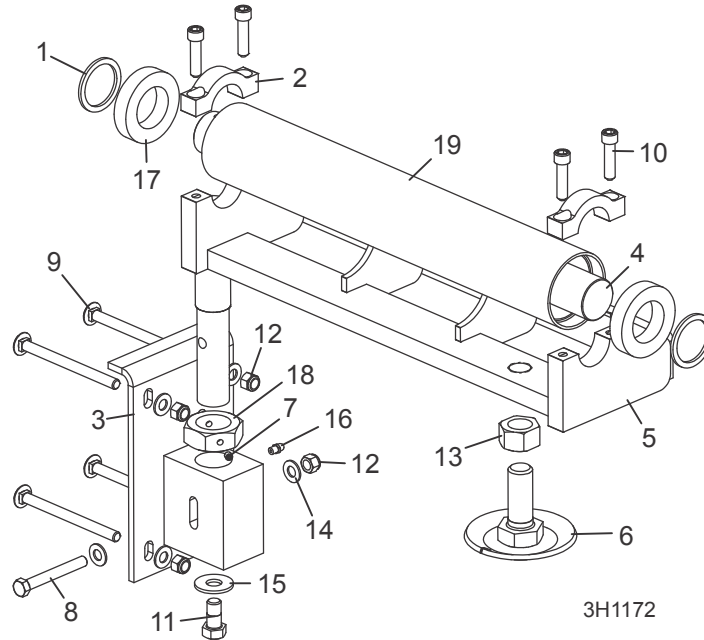

REF	DESCRIPTION (◆ Indicates Parts Available In Assemblies Only)	PART #	QTY.
	PIVOT ASSEMBLY, TAPER ROLLER	076729	1
1	Plate, 1-19/32x2x1/8 Spacer	074843	2
2	Plate, Taper Roller Cap	076234	2
3	Mount Weldment, Pivot Bed Rail	076698	1
4	Shaft, Toe Board 1-9/16 Dia	076753	1
5	Pivot Weldment, Taper Roller	076754	1
6	Roller Weldment, Taper Roller Height Adjust	079075	1
7	Screw, 1/4-28x1/4 SH Brass Tip Set	F05005-42	2
8	Bolt, 3/8-16x3 FT Hex Head	F05007-1	1
9	Bolt, 3/8-16x4 3/4 Carriage	F05007-114	4
10	Screw, 3/8-16x1 1/2 BO SHC	F05007-36	4
11	Bolt, 1/2-13x1 Hex Head	F05008-50	1
12	Nut, 3/8-16 Hex Nyloc	F05010-10	5
13	Nut, 7/8-9 Free	f05010-136	1
14	Washer, 3/8 Flat SAE	F05011-3	6
15	Washer, 9/16 Flat	F05011-52	1
16	Fitting, 1/4-28 Grease	P05060	1
17	Bearing, 1.575x2.677x.591	P13024	2
18	Nut, Pivot Rail Adjust	S13016	1
19	Tube, 2 1/2x17 1/2 Toe Board	S13020	1
	WRENCH, BED RAIL ADJUSTMENT (See Section 11.1)	015970	1

11

Bed Frame Assembly Log Side Support Assembly (Manual)

11.8 Log Side Support Assembly (Manual)

[See Section 12.11](#) for hydraulic side supports

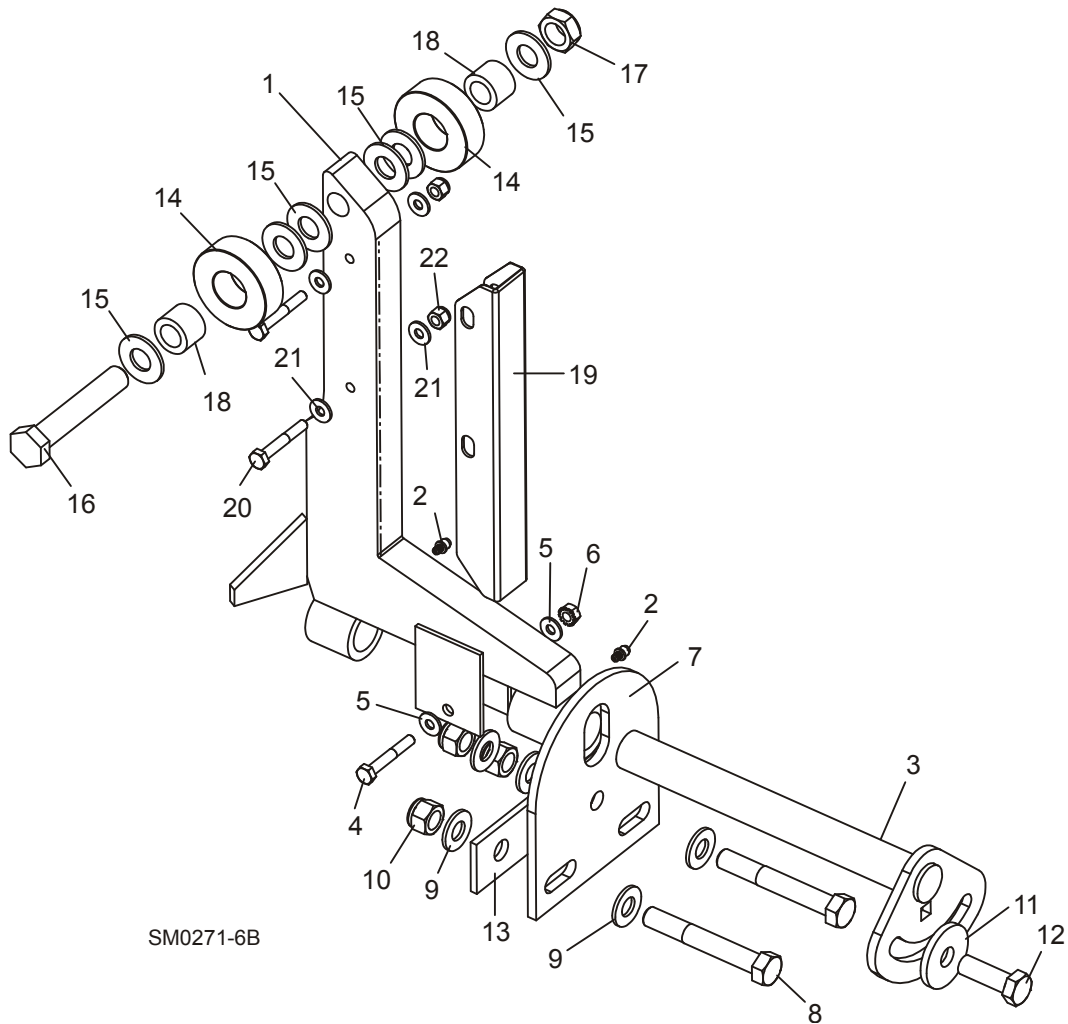

SM0271-6B

REF	DESCRIPTION (◆ Indicates Parts Available In Assemblies Only)	PART #	QTY.
1	SUPPORT, LOG SIDE	015235	2
2	Fitting, 3/16" Grease	P04107	2
	MOUNTING KIT, LOG SIDE SUPPORT	016559	2
3	Pin, Log Side Support Pivot	016544	1
4	Bolt, 1/4-20 X 1 1/2" Hex Head Grade 5	F05005-4	1
5	Washer, 1/4" SAE Flat	F05011-11	2
6	Nut, 1/4-20 Self Locking	F05010-9	1
7	Plate, Log Side Support End	016555	1
8	Bolt, 1/2-13 X 3 1/2" Hex Head Grade 5	F05008-61	2
9	Washer, 1/2" SAE Flat	F05011-2	5
10	Nut, 1/2-13 Hex Nylon Lock	F05010-8	3

11	Washer, .52" x 1.69"	014632	1	
12	Bolt, 1/2-13 X 1 1/2" Hex Head Grade 5	F05008-33	1	
13	Plate, Side Support Washer Clamp	016558	1	
	ROLLER KIT, SIDE SUPPORT	016562	4	
14	Roller, Side Support	016561	2	
15	Washer, 5/8" SAE Flat	F05011-5 ¹	6	
16	Bolt, 5/8-11 x 3 3/4" Hex Head Grade 5	F05009-118	1	
17	Nut, 5/8-11 Hex Nylon Lock Jam	F05010-96	1	
18	Bushing, Bronze 5/8" x 1" x 3/4"	016560	2	
	Bolt, 1/2-13 x 3 1/2" Carriage Head	F05008-94	1	
	Instruction Sheet, Side Support Roller	016562-526	1	
	GUARD KIT, STAINLESS STEEL SIDE SUPPORT	016798	1	
19	Guard, Stainless Steel Side Support	016722	4	
20	Bolt, 1/4-20 x 1 3/4" Hex Head	F05005-4	8	
21	Washer, 1/4" SAE Flat	F05011-11	16	
	Washer, 5/8" SAE Flat	F05011-5 ¹	4	
22	Nut, 1/4-20 Hex Nylon Lock	F05010-69	8	
	Instruction Sheet, Stainless Steel Side Support Guard Retro	016798-1005	1	

¹ Additional 5/8" SAE Flat Washer F05011-5 may be required on each side of side support to provide clearance for optional stainless steel side support guards. Extra washers are included in the stainless steel guard retrofit kit (016798).

11

Bed Frame Assembly

Safety Chain Assembly

11.9 Safety Chain Assembly

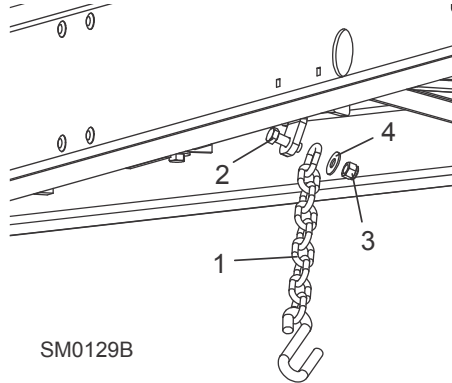

REF	DESCRIPTION (◆ Indicates Parts Available In Assemblies Only)	PART #	QTY.	
1	CHAIN, 15 INCH SAFETY	107972	1	
2	BOLT, 1/2-13X1 1/2 HEX HEAD GRADE 5	F05008-33	1	
3	NUT, 1/2-13 NYLON HEX LOCK	F05010-8	1	
4	WASHER, 7/16 STANDARD FLAT	F05011-35	1	

11.10 Saw Head Rest Pin Assembly

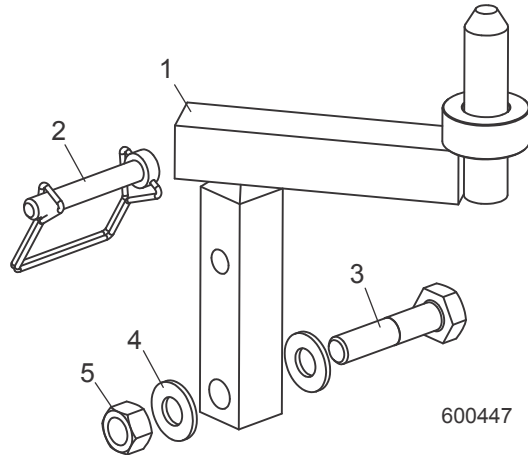

600447

REF	DESCRIPTION (◆ Indicates Parts Available In Assemblies Only)	PART #	QTY.
	PIN ASSEMBLY, LT70 REST	074596	1
	PIN ASSEMBLY, LT70 REST (WIDE HEAD)	074597	1
1	Pin, Saw Head Rest	074126 ¹	1
	Pin, Saw Head Rest (Wide Head)	074127 ¹	1
2	Pin, 3/8" x 2 1/4" Snap Retainer	014151	1
3	Bolt, 1/2-13 x 2 1/4" Hex Head Grade 5	F05008-10	1
4	Washer, 1/2" SAE Flat	F05011-2	2
5	Nut, 1/2-13 Hex Lock	F05010-3	1

¹ 074126 replaced 034442 Sawhead Rest Pin and 074127 replaced 065464 Sawhead Rest (Wide Head) Pin (Rev. B5.02).

11

Bed Frame Assembly

Bed Frame Decals

11.11 Bed Frame Decals

After 11/15/10

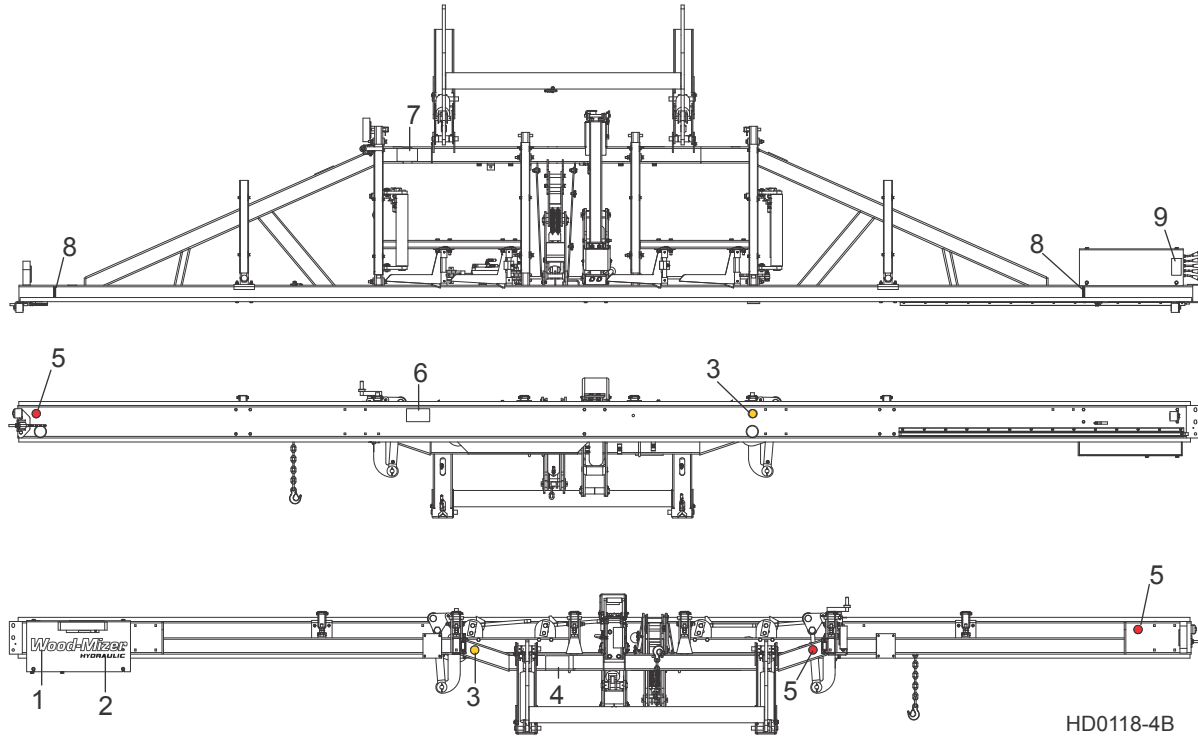

REF	DESCRIPTION (◆ Indicates Parts Available In Assemblies Only)	PART #	QTY.
1	DECAL, WHITE WOOD-MIZER EURO LOGO	065034	1
2	DECAL, HYDRAULIC EURO LOGO BLACK STD.	065035	1
3	DECAL, AMBER REFLECTIVE 2" ROUND	P07453	2
4	DECAL, KEEP AWAY DANGER	S09851	1
5	DECAL, RED REFLECTIVE 2" ROUND	P07452	3
6	DECAL, PINCH POINT DANGER	P10287	1
7	DECAL, SAW HEAD REST CAUTION	S12581	1
8	DECAL, LOG LIMIT STRIPE	S12051	2
9	DECAL, KEEP AWAY HYDRAULIC WARNING	P12961	1

11.12 Bed Frame Decals

Prior to 11/15/10

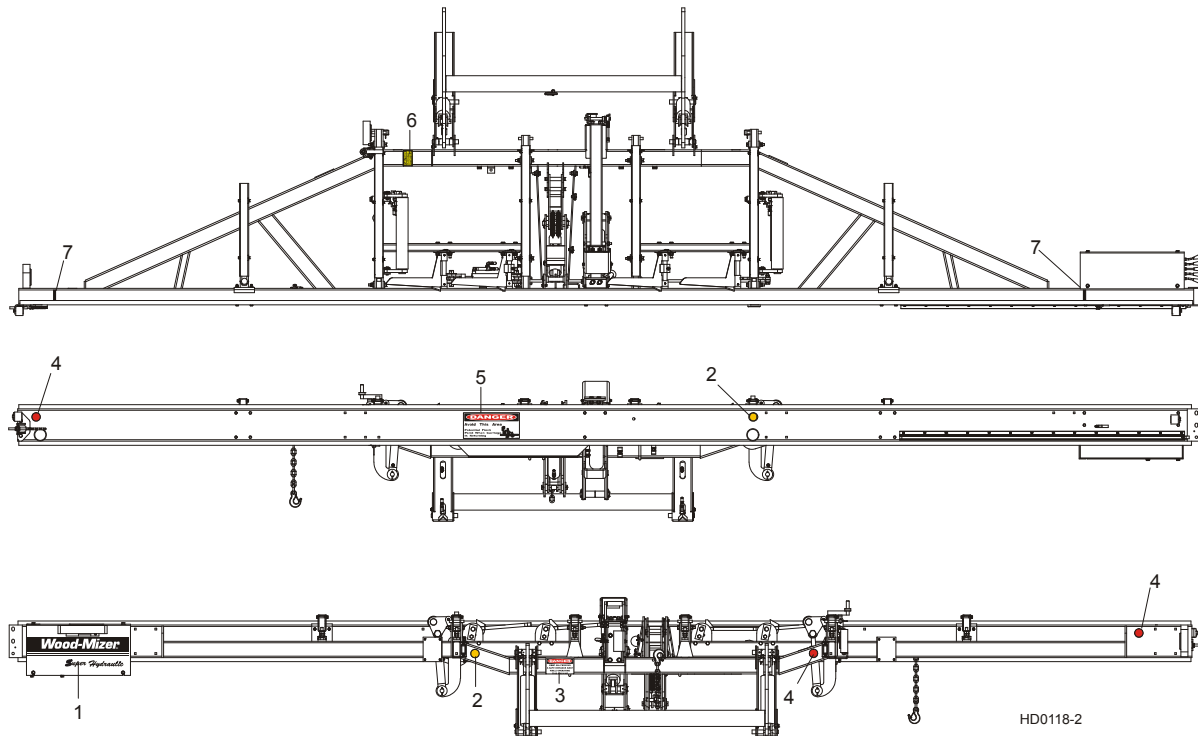

REF	DESCRIPTION (◆ Indicates Parts Available In Assemblies Only)	PART #	QTY.
1	DECAL, WOOD-MIZER LT70HD LOGO	003253	1
2	DECAL, AMBER REFLECTIVE 2" ROUND	P07453	2
3	DECAL, KEEP AWAY DANGER	S09851	1
4	DECAL, RED REFLECTIVE 2" ROUND	P07452	3
5	DECAL, PINCH POINT DANGER	P10287	1
6	DECAL, SAW HEAD REST CAUTION	S12581	1
7	DECAL, LOG LIMIT STRIPE	S12051	2

11

Bed Frame Assembly Board Outfeed Table (Optional)

11.13 Board Outfeed Table (Optional)

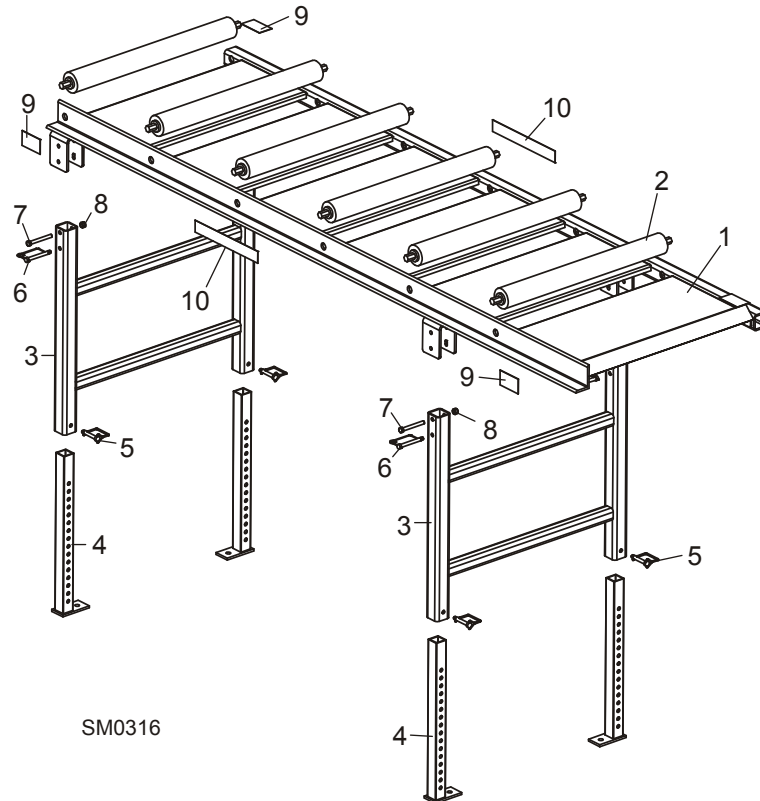

REF	DESCRIPTION (◆ Indicates Parts Available In Assemblies Only)	PART #	QTY.
	TABLE ASSEMBLY, BOARD OUTFEED	016652	1
1	Table Weldment, Board Outfeed	016606	1
2	Roller, 2 1/2" x 25"	038167	6
3	Mount Weldment, Outfeed Table Leg	016609	2
4	Leg Weldment, Outfeed Table	016651	4
5	Pin, 3/8" x 2 1/4" Square Wire Lock	014151	4
6	Pin, Snap - Coil Tension	016677	4
7	Bolt, 3/8-16 x 3 1/4" Hex Head	F05007-135	4
8	Nut, 3/8-16 Hex Nylon Lock	F05010-10	4
9	Decal, Hand Pinch Point Warning	S12641	4
10	Decal, 1 1/2" Wood-Mizer Logo	016991	2

SECTION 12 BED HYDRAULIC SYSTEM

12.1 Hydraulic Hoses

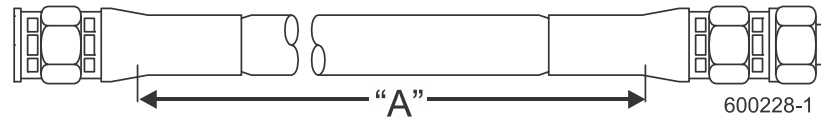

ID	Color Code	LENGTH "A"	Application (NOTE: See Hydraulic Information Section in Operator's Manual for Hydraulic Schematics)	PART #
H1	Purple	197"	1/4" Rear Toe Board Top (LT60HD)	079000-196
		219"	1/4" Rear Toe Board Top (LT70HD)	079000-219
H2	Black	197"	1/4" Rear Toe Board Base (LT60HD)	079000-196
		219"	1/4" Rear Toe Board Base (LT70HD)	079000-219
H3	Yellow	95"	1/4" Front Toe Board Top (LT60HD)	079000-95
		117"	1/4" Front Toe Board Top (LT70HD)	079000-117
H4	Gray	95"	1/4" Front Toe Board Base (LT60HD)	079000-95
		117"	1/4" Front Toe Board Base (LT70HD)	079000-117
H5	Green	182"	1/4" Clamp Up/Down Top (LT60HD)	079000-181
		204"	1/4" Clamp Up/Down Top (LT70HD)	079000-204
H6	Yellow	171"	1/4" Clamp Up/Down Base (LT60HD)	079000-173
		193"	1/4" Clamp Up/Down Base (LT70HD)	079000-194
H7	Red	156"	3/8" Loading Arm Base (LT60HD)	079001-156
		178"	3/8" Loading Arm Base (LT70HD)	079001-178
H8	Blue	156"	3/8" Loading Arm Top (LT60HD)	079001-156
		178"	3/8" Loading Arm Top (LT70HD)	079001-178
H9	Orange	65"	3/8" Side Support Base	079001-65
H10	Plain	73"	3/8" Side Support Top	079001-73
H11	Orange	181"	3/8" Clamp In/Out Base (LT60HD)	079001-181
		177"	3/8" Clamp In/Out Base (LT70HD)	079001-177
H12	White	129"	3/8" Clamp In/Out Top (LT60HD)	079001-129
		151"	3/8" Clamp In/Out Top (LT70HD)	079001-151
H13	Green	38"	3/8" Loading Arm Branch Top	079001-38
H14	Green	77"	3/8" Loading Arm Branch Top	079001-77
H15	Yellow	81"	3/8" Loading Arm Branch Base	079001-81
H16	Yellow	43"	3/8" Loading Arm Branch Base	079001-43
H17	Plain	159"	3/8" Log Turner Base (LT60HD)	079001-159
		181"	3/8" Log Turner Base (LT70HD)	079001-181
H18	Pink	159"	3/8" Log Turner Top (LT60HD)	079001-159
		181"	3/8" Log Turner Top (LT70HD)	079001-181
H19	Purple	164"	3/8" Log Turner Motor Top (LT60HD)	079001-164
		177"	3/8" Log Turner Motor (LT70HD Nearest Frame)	079001-177

12**Bed Hydraulic System***Hydraulic Hoses*

H20	Black	163"	3/8" Log Turner Motor Base (LT60HD)	079001-163
		180"	3/8" Log Turner Motor (LT70HD Furthest from Frame)	079001-180
H21	Plain	15"	1/4" Pump To Valve (two hoses)	057964
H22	Plain	6 1/2"	3/8" Gauge To Valve	079001-6.5

12.2 Hydraulic Pump Box (DC)

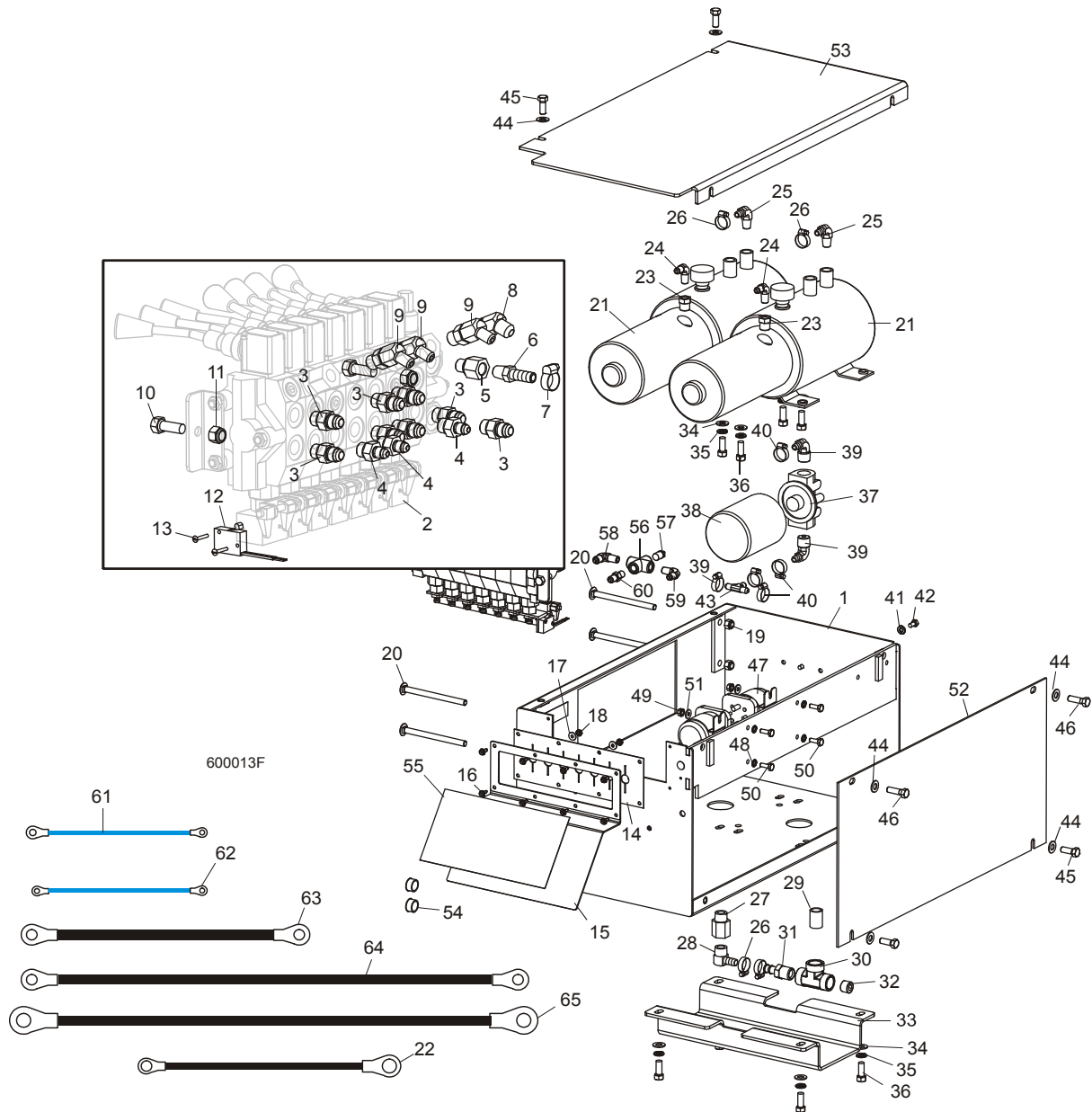

REF	DESCRIPTION (◆ Indicates Parts Available In Assemblies Only)	PART #	QTY.
	BOX ASSEMBLY, LT60/70 DC HYDRAULIC CONTROL	017649	1
1	Box Weldment, Hydraulic Control	034383	1
	Valve Assembly, 7-Section Hydraulic	034533	1
2	Valve, 7-Section Hydraulic	034451	1
3	Fitting, 3/8" O-Ring x 3/8" JIC	014687	8

12

Bed Hydraulic System

Hydraulic Pump Box (DC)

4	Fitting, 1/4" JIC x 3/8" O-Ring	P26284	3	
5	Fitting, #6 SAE x 1/4" NPT Female	014686	1	
6	Fitting, 1/4" NPT x 3/8" Hose Barb	014685	1	
7	Clamp, 11/16" Hose	P12739	1	
8	Fitting, #6 SAE 45° Elbow	015489	1	
9	Fitting, #4 SAE x #6 SAE 45° Elbow	015488	3	
10	Bolt, 3/8-16 x 1" Hex Head	F05007-7	2	
11	Nut, 3/8-16 Hex Nylon Lock	F05010-10	2	
12	Switch, Hydraulic Valve Lever	024198	1	
13	Screw, #4-40 x 3/4" Slotted Head	F05004-13	2	
14	Seal, 7-Handle Valve Rubber	034202	1	
15	Plate, 7-Handle Decal	033999	1	
16	Screw, #10-24 x 1/2" Self-Tapping	F05015-7	8	
17	Washer, #10 SAE Flat	F05011-18	2	
18	Nut, #10-24 Hex Self-Locking	F05010-14	2	
19	Nut, 3/8-16 Hex Nylon Lock	F05010-10	4	
20	Bolt, 3/8-16 x 5" Carriage Head	F05007-113	4	
	Pump Assembly, LT60/70 DC Hydraulic	034534	1	
21	Pump Kit, Hydraulic w/Motor	061764	2	
	Pump, Hydraulic Replacement Monarch Model #12070	016199	1	
	Motor Kit, Hydraulic Replacement	052807	1	
	Motor, 12 VDC Hydraulic Pump #08714 (Iskra)	038683	1	◆
	Brush Kit, 4-Valve Hydraulic Pump Motor #08658-I (Iskra)	038682	1	
	Bearing, Base Motor #02318	P12513	1	
22	Wire Assembly, Motor Brush Ground	052806	1	
	Cap, Hydraulic Pump Vented Fill #03171	P12817	1	
	O-Ring, Hydraulic Pump/Reservoir #02352	P10198	1	
	Seal, Hydraulic Pump/Motor #02330	P10315	1	
23	Fitting, 3/8" NPT x 1/4" NPT Reducer	015490	2	
24	Fitting, 1/4" NPT x 1/4" JIC Elbow	P09142	2	
25	Fitting, 3/8" NPT x 3/8" Hose Barb Elbow	P12708	2	
26	Clamp, 11/16" Hose	P12739	4	
27	Fitting, 1/2" NPT x 1/2" NPT Adapter	015995	1	
28	Fitting, 1/2" NPT x 1/2" Hose Barb Elbow	015997	1	
29	Fitting, 1/2" NPT Close Brass Nipple	016795	1	
30	Fitting, 1/2" NPT Female Tee	016793	1	
31	Fitting, 1/2" NPT Male x 1/2" Hose Barb	016794	1	
32	Fitting, 1/2" NPT Pipe Plug	P26258	1	
33	Guard, Crossover Hose	015992	1	
34	Washer, 3/8" SAE Flat	F05011-3	8	
35	Washer, 3/8" Split Lock	F05011-4	8	
36	Bolt, 3/8-16 x 1" Hex Head	F05007-7	8	
37	Manifold, Hydraulic Filter w/Cartridge	P22683	1	

38	Filter, S28 Hydraulic Cartridge	P20301	1	
39	Fitting, 1/2" NPT x 3/8" Hose Barb Elbow	P12707	2	
40	Clamp, 11/16" Hose Clamp	P12739	2	
41	Washer, 1/4" Split Lock	F05011-14	2	
42	Bolt, 1/4-20 x 1/2" Hex Head	F05005-15	2	
43	Fitting, 3/8" Hose Barb Tee	015485	1	
44	Washer, 3/8" SAE Flat	F05011-3	6	
45	Bolt, 3/8-16 x 1" Hex Head Grade 5	F05007-87	4	
46	Bolt, 3/8-16 x 1 1/4" Hex Head	F05007-2	2	
47	Solenoid Kit, 200A 12V SPST Hydraulic Motor	016371	2	
	Solenoid, 200A 12V SPST Cont. Duty	015470	1	◆
	Diode Assembly, Solenoid Coil Chassis Gnd	015426	1	
48	Washer, 1/4" External Lock	F05011-37	4	
49	Nut, 1/4-20 Hex Self-Locking	F05010-9	4	
50	Bolt, 1/4-20 x 3/4" Hex Head Full Thread	F05005-1	4	
51	Washer, 1/4" SAE Flat	F05011-11	4	
52	Plate, Hydraulic Control Box Side	015227	1	
53	Plate, Hydraulic Control Box Top	015228	1	
54	Grommet, 5/8" Wire	P04137	2	
55	Decal, Hydraulic Control Lever	017669	1	
56	Fitting, 1/4" NPT Cross	P22311	1	
57	Plug, 1/4" NPT Pipe	P05498 ¹	1	
58	Fitting, 3/8" JIC x 1/4" NPT Elbow	015491	1	
59	Fitting, 1/4" NPT x 1/4" JIC Male Elbow	P09142	1	
60	Fitting, 1/4" NPT x 1/4" JIC Male	P09143	1	
	Hose, 3/8" x 6 1/2" Hydraulic w/Fittings	036303	1	
	Hose, 1/4" x 15" Hydraulic w/Fittings	036292	2	
61	WIRE ASSEMBLY, 14 GA X 4" #10 & 5/16" RING TERMINALS	036315	2	
62	WIRE ASSEMBLY, 14 GA X 4" #10 RING TERMINALS	036314	1	
63	CABLE ASSEMBLY, 1 GA X 6" HYDRAULIC PUMP TO SOLENOID	036311	1	
64	CABLE ASSEMBLY, 1 GA X 16" HYDRAULIC PUMP TO SOLENOID	036310	1	
65	CABLE ASSEMBLY, 1 GA X 16" HYDRAULIC PUMP GROUND	036312	2	
	WASHER, 3/8" STAR EXTERNAL	F05011-36	3	

¹ Replaces 5000 PSI Hydraulic Pressure Gauge P10052 (LT60HD/LT70HD Rev. B4.11).

12.3 Hydraulic Pump Box (230/460V AC)

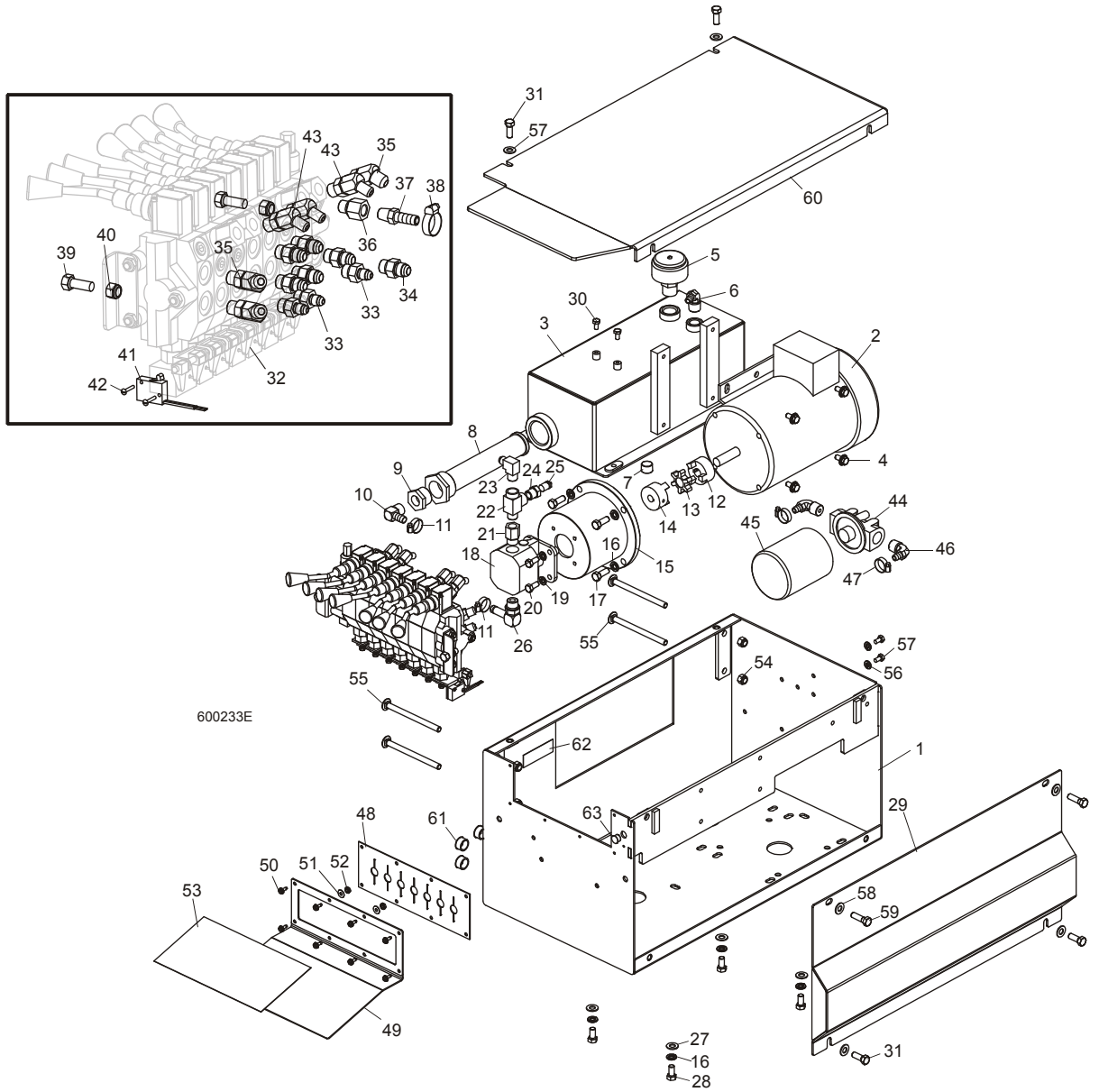

REF	DESCRIPTION (◆ Indicates Parts Available In Assemblies Only)	PART #	QTY.
	BOX ASSEMBLY, LT60/70 230/460V AC HYDRAULIC CONTROL	017677	1
1	Box Weldment, Hydraulic Control	034383	1
	Pump Assembly, 230/460V AC	038963	1
2	Motor, 3HP 230/460V 56C 3450RPM	055312	1
3	Tank Weldment, LT70 Hydraulic	054825	1
4	Bolt, 5/16-18 x 3/4" Hex Head w/Flat & Lock Washer	F05006-101	4

Bed Hydraulic System

Hydraulic Pump Box (230/460V AC)

12

5	Cap, Hydraulic Breather/Filter	P20212	1	
6	Fitting, 1/2" NPT x 3/8" Hose Barb Elbow	P12707	1	
7	Fitting, 1/2" NPT Pipe Plug	P26258	1	
8	Filter, Hydraulic Tank Suction	P20210	1	
9	Fitting, 1/2" NPT x 1" NPT Bushing	P20239	1	
10	Fitting, 1/2" NPT x 1/2" Hose Barb Elbow	015997	1	
11	Clamp, 11/16" Hose	P12739	2	
12	Coupling Body, L075 x 5/8"	038951	1	
13	Coupling Spider, L075	P20218	1	
14	Coupling Body, L075 x 1/2"	P20217	1	
15	Adaptor, Hydraulic Motor to Pump	P20215	1	
16	Washer, 3/8" Split Lock	F05011-4	8	
17	Bolt, 3/8-16 x 1" Hex Head Grade 5	F05007-87	4	
18	Pump, Hydraulic	P20213	1	
19	Washer, 5/16" Split Lock	F05011-13	4	
20	Bolt, 5/16-18 x 3/4" Hex Head Grade 5	F05006-102	4	
21	Fitting, #8 SAE x 3/8" NPT Female	P12706	1	
22	Fitting, 3/8" NPT Male Run Tee	016822	1	
23	Fitting, 3/8" NPT x 3/8" JIC Elbow	016820	1	
24	Fitting, 3/8" NPT x 1/4" NPT Reducer	015490	1	
25	Plug, 1/4" NPT Pipe	P05498 ¹	1	
26	Fitting, #8 SAE x 1/2" Hose Barb Elbow	038949	1	
27	Washer, 3/8" SAE Flat	F05011-3	4	
28	Bolt, 3/8-16 x 3/4" Hex Head	F05007-27	4	
29	Plate Weldment, Hydraulic Control Box Side	038966	1	
30	Bolt, 1/4-20 x 1/2" Hex Head	F05005-15	2	
	Hose, 3/8" x 24" Hydraulic	003260	1	
	Hose, 1/2" ID Low Pressure Hydraulic	R02133	.67 ft.	
	Hose, 3/8" ID Low Pressure Hydraulic	R01892-1	3.5 ft.	
31	Bolt, 3/8-16 x 1" Hex Head Grade 5	F05007-87	4	
	Valve Assembly, 7-Section AC Hydraulic	017684	1	
32	Valve, 7-Section Hydraulic	034451	1	
33	Fitting, 1/4" JIC x 3/8" O-Ring	P26284	3	
34	Fitting, 3/8" O-Ring x 3/8" JIC	014687	6	
35	Fitting, #6 SAE 45° Elbow	015489	3	
36	Fitting, #6 SAE x 1/4" NPT Female	014686	1	
37	Fitting, 1/4" NPT x 3/8" Hose Barb	014685	1	
38	Clamp, 11/16" Hose	P12739	1	
39	Bolt, 3/8-16 x 1" Hex Head	F05007-7	2	
40	Nut, 3/8-16 Hex Nylon Lock	F05010-10	2	
41	Switch, Hydraulic Valve Lever	024198	1	
42	Screw, #4-40 x 3/4" Slotted Head	F05004-13	2	
43	Fitting, #4 SAE x #6 SAE 45° Elbow	015488	3	

12

Bed Hydraulic System Hydraulic Pump Box (230/460V AC)

44	Manifold, Hydraulic Filter w/Cartridge	P22683	1	
45	Filter, S28 Hydraulic Cartridge	P20301	1	
46	Fitting, 1/2" NPT x 3/8" Hose Barb Elbow	P12707	2	
47	Clamp, 11/16" Hose	P12739	2	
48	Seal, 7-Handle Valve Rubber	034202	1	
49	Plate, 7-Handle Decal	017771	1	
50	Screw, #10-24 x 1/2" Self-Tapping	F05015-7	8	
51	Washer, #10 SAE Flat	F05011-18	2	
52	Nut, #10-24 Hex Self-Locking	F05010-14	2	
53	Decal, Hydraulic Control Lever	017669	1	
54	Nut, 3/8-16 Hex Nylon Lock	F05010-10	4	
55	Bolt, 3/8-16 x 5" Carriage Head	F05007-113	4	
56	Washer, 1/4" Split Lock	F05011-14	2	
57	Bolt, 1/4-20 x 1/2" Hex Head	F05005-15	2	
58	Washer, 3/8" SAE Flat	F05011-3	6	
59	Bolt, 3/8-16 x 1 1/4" Hex Head	F05007-2	2	
60	Plate, Hydraulic Control Box Top	015228	1	
61	Grommet, 5/8" Wire	P04137	3	
62	Decal, Hyd. Fluid Replacement Info	S12825	1	
63	Plug, 1/2" Hole	036244	1	

¹ Replaces 5000 PSI Hydraulic Pressure Gauge P10052 (Rev. B4.11).

12.4 Hydraulic Pump Box (575V AC)

LT60/70

Rev. B3.02 - B4.04

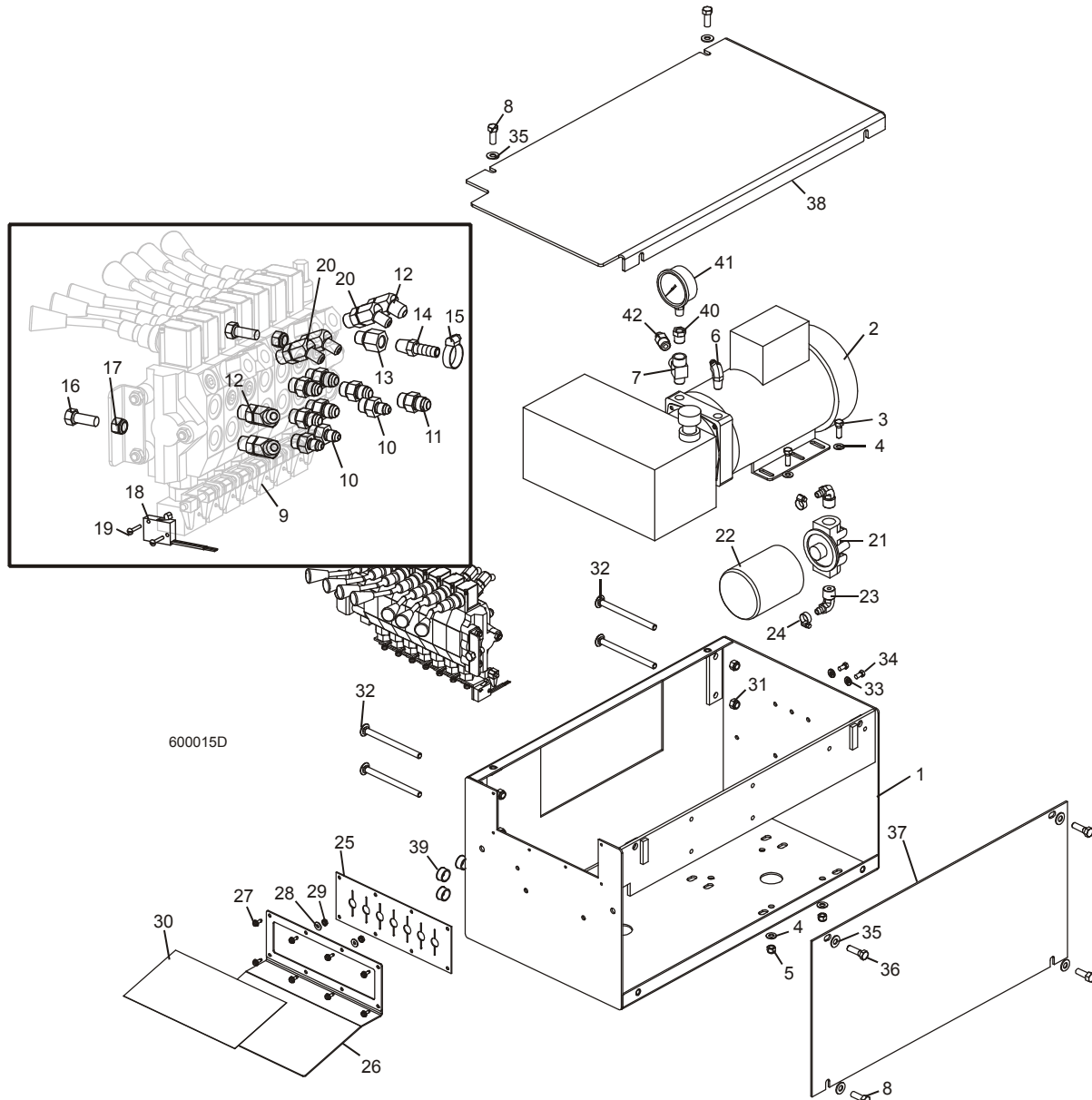

REF	DESCRIPTION (◆ Indicates Parts Available In Assemblies Only)	PART #	QTY.
	BOX ASSEMBLY, LT60/70 575V AC HYDRAULIC CONTROL	036438 ¹	1
1	Box Weldment, Hydraulic Control	034383	1
2	Pump, Hydraulic 575V AC w/Tank	034794	1
3	Bolt, 5/16-18 x 1" Hex Head	F05006-1	4
4	Washer, 5/16" SAE Flat	F05011-17	8
5	Nut, 5/16-18 Nylon Lock	F05010-58	4

12

Bed Hydraulic System Hydraulic Pump Box (575V AC)

6	Fitting, 3/8" NPT x 3/8" Hose Barb Elbow	P12708	1	
7	Fitting, 3/8" NPT Male Run Tee	016822	1	
8	Bolt, 3/8-16 x 1" Hex Head Grade 5	F05007-87	4	
	Valve Assembly, 7-Section AC Hydraulic	017684	1	
9	Valve, 7-Section Hydraulic	034451	1	
10	Fitting, 1/4" JIC x 3/8" O-Ring	P26284	3	
11	Fitting, 3/8" O-Ring x 3/8" JIC	014687	6	
12	Fitting, #6 SAE 45° Elbow	015489	3	
13	Fitting, #6 SAE x 1/4" NPT Female	014686	1	
14	Fitting, 1/4" NPT x 3/8" Hose Barb	014685	1	
15	Clamp, 11/16" Hose	P12739	1	
16	Bolt, 3/8-16 x 1" Hex Head	F05007-7	2	
17	Nut, 3/8-16 Hex Nylon Lock	F05010-10	2	
18	Switch, Hydraulic Valve Lever	024198	1	
19	Screw, #4-40 x 3/4" Slotted Head	F05004-13	2	
20	Fitting, #4 SAE x #6 SAE 45° Elbow	015488	3	
21	Manifold, Hydraulic Filter w/Cartridge	P22683	1	
22	Filter, S28 Hydraulic Cartridge	P20301	1	
23	Fitting, 1/2" NPT x 3/8" Hose Barb Elbow	P12707	2	
24	Clamp, 11/16" Hose Clamp	P12739	2	
25	Seal, 7-Handle Valve Rubber	034202	1	
26	Plate, 7-Handle Decal	017771	1	
27	Screw, #10-24 x 1/2" Self-Tapping	F05015-7	8	
28	Washer, #10 SAE Flat	F05011-18	2	
29	Nut, #10-24 Hex Self-Locking	F05010-14	2	
30	Decal, Hydraulic Control Lever	017669	1	
31	Nut, 3/8-16 Hex Nylon Lock	F05010-10	4	
32	Bolt, 3/8-16 x 5" Carriage Head	F05007-113	4	
33	Washer, 1/4" Split Lock	F05011-14	2	
34	Bolt, 1/4-20 x 1/2" Hex Head	F05005-15	2	
35	Washer, 3/8" SAE Flat	F05011-3	6	
36	Bolt, 3/8-16 x 1 1/4" Hex Head	F05007-2	2	
37	Plate, Hydraulic Control Box Side	015227	1	
38	Plate, Hydraulic Control Box Top	015228	1	
39	Grommet, 5/8" Wire	P04137	3	
40	Fitting, 3/8" NPT x 1/4" NPT Reducer	015490	1	
41	Gauge, 5000 PSI Hydraulic	P10052	1	
42	Fitting, 3/8" NPT x 3/8" JIC Elbow	016819	1	

¹ No longer available for sawmills Rev. B4.05 and later.

12.5 Hydraulic Control Box (230/460V AC)

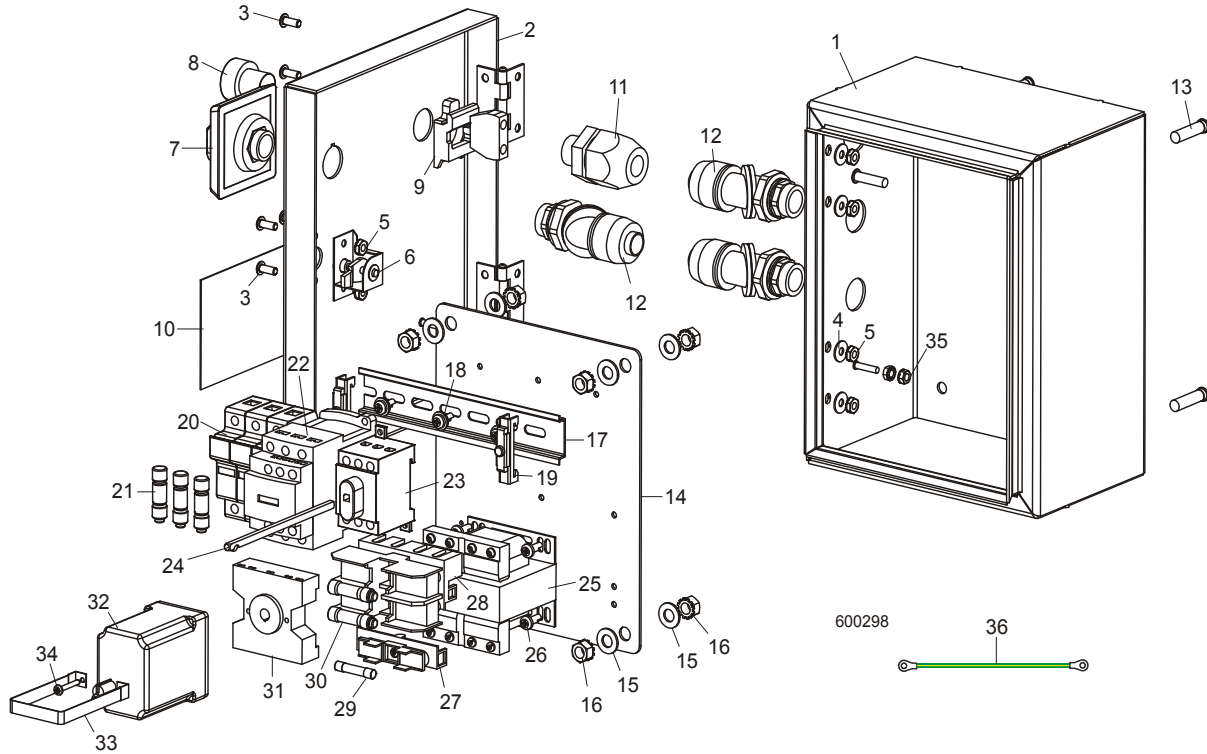

REF	DESCRIPTION (◆ Indicates Parts Available In Assemblies Only)	PART #	QTY.
	CONTROL ASSEMBLY, LT70 E25-L HYDRAULIC	052384	1
	CONTROL ASSEMBLY, LT70 E25-H/E30-H HYDRAULIC	052385	1
1	Box Weldment, Hydraulic AC Control	050302	1
2	Door Weldment, Hydraulic AC Control Box	052379	1
3	Screw, #10-24 x 1/2" Socket Button Head Stainless	F05004-196	6
4	Washer, #10 SAE Flat	F05011-18	4
5	Nut, #10-24 Self-Locking Hex	F05010-14	6
6	Latch, Door	051978	1
7	Switch, Red/Yellow Disconnect 6mm	050883-1	1
8	Switch Head, Green Guarded	050152	1
9	Switch Body, 1NO 22mm ZB4	025242	1
10	Decal, Electrical Hazard 2 Places	051948	1
11	Connector, 1/2" Liquid-Tite Straight	E22721	1
12	Connector, 1/2" Liquid-Tite Swivel	051750	3
13	Stud, 5/16-18 x 1 1/4" Type CH Clinch	F05006-113	4
14	Plate, LT70 AC Hydraulic Control Insert	052377	1
15	Washer, 5/16" SAE Flat	F05011-17	8
16	Nut, 5/16-18 Self-Locking Hex	F05010-20	8
17	Rail, 35mm x 7.5mm x 6.875" Steel DIN	024474-6_875	1

12

Bed Hydraulic System Hydraulic Control Box (230/460V AC)

18	Screw, #10-24 x 1/2" Phillips Head	F05004-186	3	
19	Clamp, Plastic DIN Rail	E22707	2	
20	Fuse Holder, 3P Class CC Finger Safe	052380	1	
21	Fuse, 15A 600V Class CC Delay (E25-L)	052513	3	
	Fuse, 8A 600V Class CC Delay (E25-H/E30-H)	052381	3	
22	Contactor, 18A 3P 24VAC Coil (E25-L)	052689	1	
	Contactor, 9A 3P 24VAC Coil (E25-H/E30-H)	025290	1	
23	Disconnect, 40A 3P Non-Fused	050903-1	1	
24	Shaft, .2x.2 x 4.7" Disconnect	050882-1	1	
25	Transformer, 240/480-24VAC 50VA	053009	1	
26	Screw, #10-24 x 1/2" Phillips Pan Head Type 23	F05015-17	4	
27	Fuse Block, T50 Transformer Secondary	053011	1	
28	Fuse Block, T50 Transformer Primary	053010	1	
29	Fuse, 3A 250V 1/4x1 1/4 MDL Delay	025297	1	
30	Fuse, 4/10A 600V KLDR Class CC	P03151	2	
31	Socket, 11-Pin Relay	E22700	1	
32	Relay, .1-10s 24VDC Coil Timer Off Delay	052383	1	
33	Strap, Timer Relay Retaining	050967	1	
34	Screw, M8 x 1.25 x 1 Hex Head Full Thread	F05004-42	2	
35	Nut, #8-32 Self-Locking Hex	F05010-41	2	
36	Wire Assembly, 10" Ground	025187	1	

12.6 Hydraulic Control Box (575V AC)

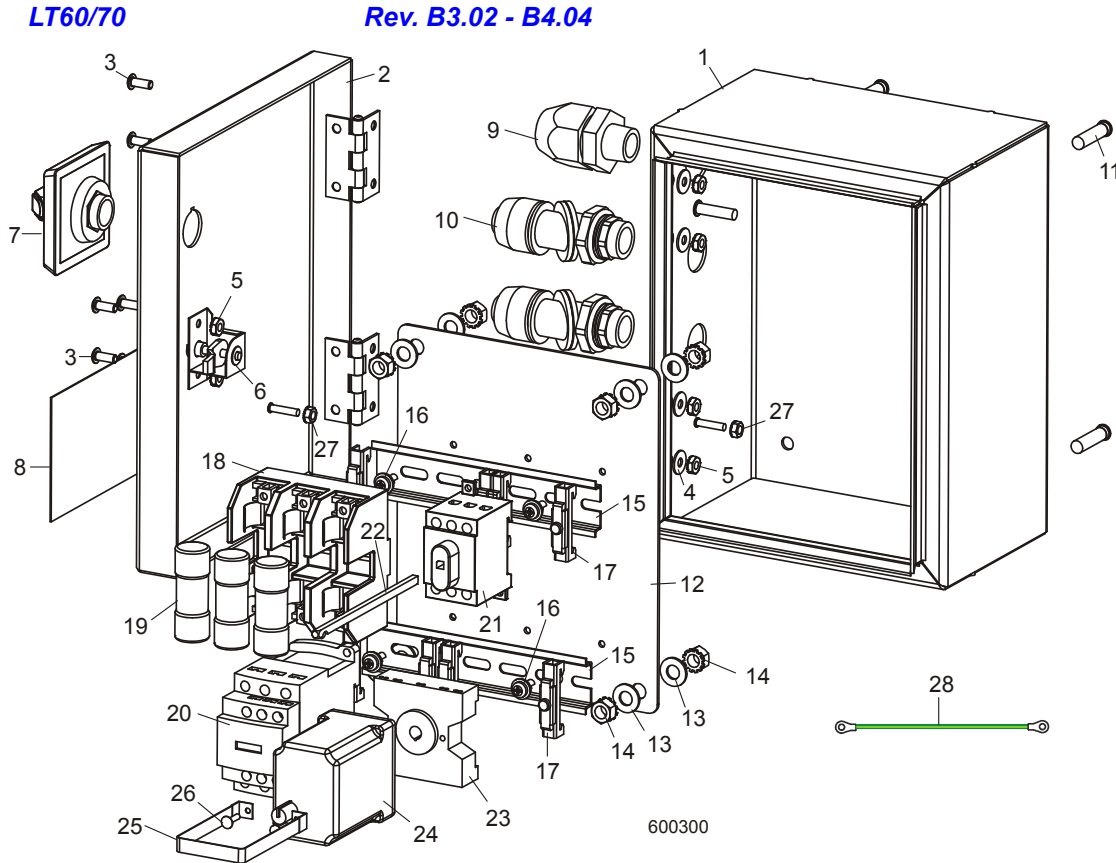

REF	DESCRIPTION (◆ Indicates Parts Available In Assemblies Only)	PART #	QTY.
	CONTROL ASSEMBLY, LT70 E25-C HYDRAULIC	050277 ¹	1
1	Box Weldment, Hydraulic AC Control	050302	1
2	Door Weldment, Hydraulic AC Control Box	050307	1
3	Screw, #10-24 x 1/2" Socket Button Head Stainless	F05004-196	6
4	Washer, #10 SAE Flat	F05011-18	4
5	Nut, #10-24 Self-Locking Hex	F05010-14	6
6	Latch, Door	051978	1
7	Switch, Red/Yellow Disconnect 6mm	050883-1	1
8	Decal, Electrical Hazard 2 Places	051948	1
9	Connector, 1/2" Liquid-Tite Straight	E22721	1
10	Connector, 1/2" Liquid-Tite Swivel	051750	3
11	Stud, 5/16-18 x 1 1/4" Type CH Clinch	F05006-113	4
12	Plate, LT70 AC Hydraulic Control Insert	050306	1
13	Washer, 5/16" SAE Flat	F05011-17	8
14	Nut, 5/16-18 Self-Locking Hex	F05010-20	8
15	Rail, 35mm x 7.5mm x 6" Steel DIN	024474-6	2

12**Bed Hydraulic System**
Hydraulic Control Box (575V AC)

16	Screw, #10-24 x 1/2" Phillips Head	F05004-186	4	
17	Clamp, Plastic DIN Rail	E22707	8	
18	Fuse Block, 30A 600V 3P Class J	050345	1	
19	Fuse, 8A 600V Class J	E22715	3	
20	Contactor, 18A 3P 12VDC Coil	050332	1	
21	Disconnect, 40A 3P Non-Fused 6mm	050903-1	1	
22	Shaft, Disconnect Extension 6mm	050882-1	1	
23	Socket, 11-Pin Relay	E22700	1	
24	Relay, .1-10s 12VDC Coil Timer Off Delay	050314	1	
25	Strap, Timer Relay Retaining	050967	1	
26	Rivet, 1/8" x 1/2" STI SS48D Pop	F04203-5	2	
27	Nut, #8-32 Self-Locking Hex	F05010-41	2	
28	Wire Assembly, 10" Ground	025187	1	

¹ No longer available for sawmills Rev. B4.05 and later.

12.7 Hydraulic Power Supply Strip (DC Only)

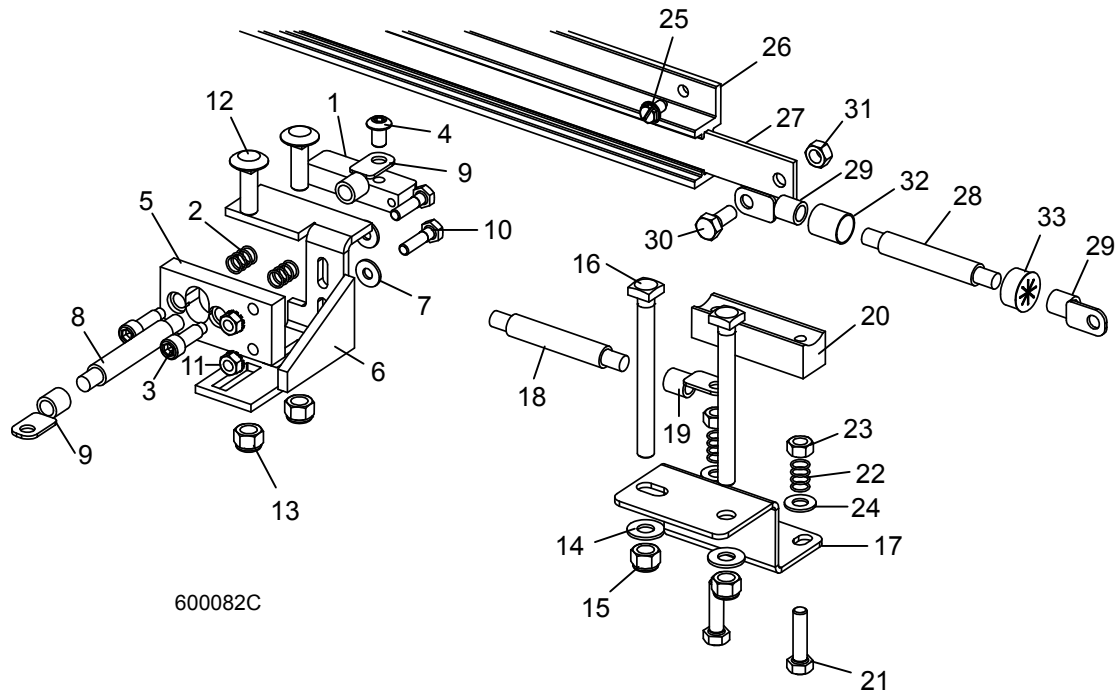

REF	DESCRIPTION (◆ Indicates Parts Available In Assemblies Only)	PART #	QTY.	
	CONTACT ASSEMBLY, HYDRAULIC POWER SUPPLY (POSITIVE)	010103	1	
	Contact Kit, 97+ Hydraulic Power Supply Positive	007716	1	
1	Contact, Hydraulic Power Supply (Positive)	015253	1	◆
2	Spring, Positive Contact	P10077	2	
3	Bolt, 5/16" X 3/4" Shoulder (1/4-20 Thread) Stainless	F05006-143	2	
4	Bolt, 5/16-18 x 1/2" Socket Button Head	F05006-20	1	
5	Insulator, Positive Contact	S10072	1	
6	Bracket, Positive Contact Mounting	015324	1	
7	Washer, 1/4" SAE Flat	F05011-11	2	
8	Cable, #1 Weld	R01971	1.17 Ft	◆
9	Terminal, 5/16" Ring #2 Gauge	F05092-16	2	
10	Bolt, 1/4-20 X 1" Hex Head Grade 2	F05005-38	2	
11	Nut, 1/4-20 Hex Self-Locking	F05010-9	2	
12	Bolt, 3/8-16 X 1 1/4" Carriage Head	F05007-11	2	
13	Nut, 3/8-16 Hex Nylon Lock	F05010-10	2	
	CONTACT KIT, HYDRAULIC POWER SUPPLY (GROUND)	017948	1	
14	Washer, 3/8" SAE Flat	F05011-3	2	
15	Nut, 3/8-16 Hex Nylon Lock	F05010-10	2	
16	Bolt, 3/8-16 X 4" Square Head	F05007-175	2	
17	Bracket, Ground Contact Mounting	017949	1	

12

Bed Hydraulic System Hydraulic Power Supply Strip (DC Only)

18	Cable Assy, Hydraulic Negative Contact (Ground) #1 Weld	036306	1	
	Cable, #1 Weld	R01971	2.2 Ft	◆
19	Terminal, 5/16" Ring #2 Gauge	F05092-16	2	
	Contact Kit, Hydraulic Power Supply Ground	007717	1	
20	Contact, Hydraulic Power Supply (Ground)	015264	1	◆
21	Bolt, 5/16-18 X 1 1/4" Hex Head Full Thread Grade 5	F05006-93	2	
22	Spring, Ground Contact	P10077	2	
23	Nut, 5/16-18 Hex	F05010-17	2	
24	Washer, 5/16" SAE Flat	F05011-17	2	
	STRIP ASSEMBLY, 6' HYDRAULIC POWER SUPPLY W/2 3FT. CABLES	015564	1	
25	Screw, 1/4-20 X 1/2" Slotted Hex Head	F05015-1	8	
26	Housing, 6' Contact Strip	P11976	1	
	Strip, 6' Contact With 2Cables	015886	1	
27	Strip, 6' Contact	S10075	1	◆
28	Cable Assembly, Hydraulic Contact Strip	052161	2	
	Cable, #1 Weld	R01971	3 Ft	◆
29	Terminal, 5/16" Ring #2 Gauge	F05092-16	2	
30	Bolt, 5/16-18 X 3/4" Hex Head Black Nylon	F05006-45	1	
31	Nut, 5/16-18 Hex Black Nylon	F05010-86	1	
32	Tube, 5/8" Heat Shrink w/Adhesive ID	R01950-8	.33 Ft	◆
33	Grommet, 5/8" Wire	P04137	1	

12.8 Hydraulic Power Supply Strip (575V AC Only)

LT60HD/70HD

Rev. B3.02 - B4.04

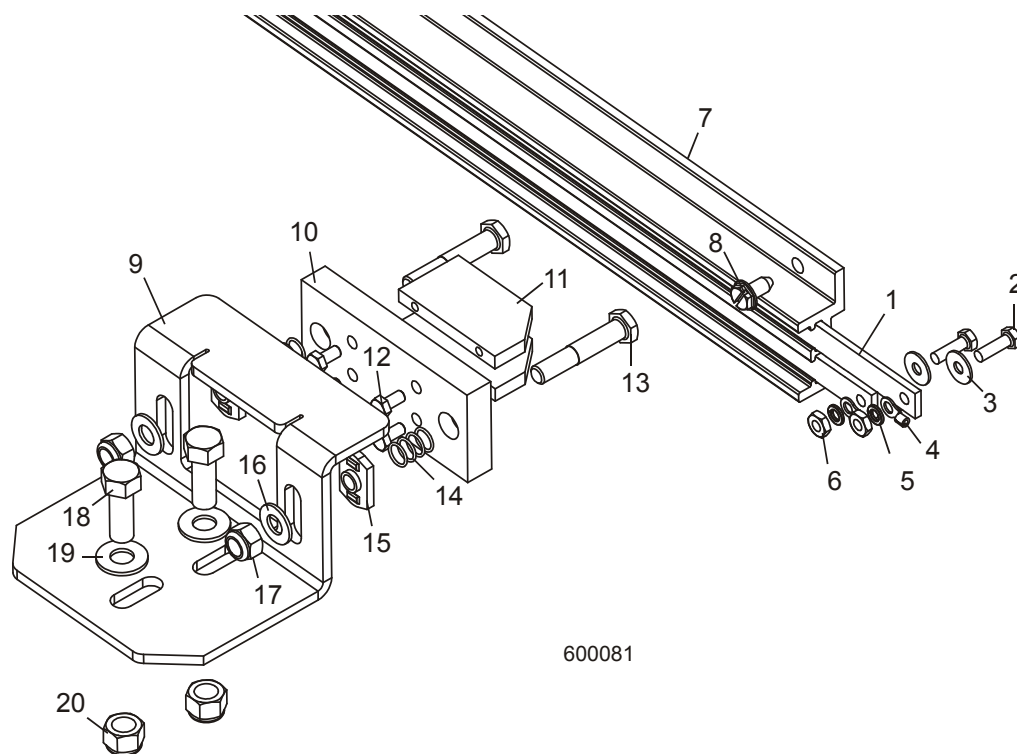

REF	DESCRIPTION (◆ Indicates Parts Available In Assemblies Only)	PART #	QTY.
	STRIP ASSEMBLY, HYDRAULIC POWER SUPPLY (AC)	034867	1
1	Strip, AC Hydraulic Power Supply	034866	2
2	Bolt, #10-32 x 5/8" Hex Head	F05004-152	2
3	Washer, #10 Brass	042867	2
4	Terminal, #10 14-16 Gauge Ring NI Loose	F05092-9	2
5	Washer, #10 Split Lock	F05011-20	1
6	Nut, #10-32 Hex	F05010-27	2
7	Housing, AC Hydraulic Power Supply	044015	1
8	Bolt, 1/4-20 x 1/2" Self-Tapping Hex Head	F05015-1	8
	CONTACT, HYDRAULIC POWER SUPPLY (AC)	034880	1
9	Bracket, Contact Mounting	034879	1
10	Block, AC Contact Insulating	034874	1
11	Block, AC Contact	034869	2
12	Bolt, #10-32 x 1/2" Hex Head	F05004-60	4
13	Bolt, 5/16-18 x 1 3/4" Hex Head	F05009-70	2
14	Spring, .42" x .59" x .042" Compression	P10077	2
15	Nut, 5/16-18 Stainless Steel Weld	F05010-179	2
16	Washer, 5/16" SAE Flat	F05011-17	2

12**Bed Hydraulic System***Hydraulic Power Supply Strip (575V AC Only)*

17	Nut, 5/16-18 Hex Nylon Lock	F05010-58	2	
18	Bolt, 3/8-16 x 1" Hex Head	F05007-7	2	
19	Washer, 3/8" SAE Flat	F05011-3	2	
20	Nut, 3/8-16 Hex Nylon Lock	F05010-10	2	

12.9 Hydraulic Log Loader

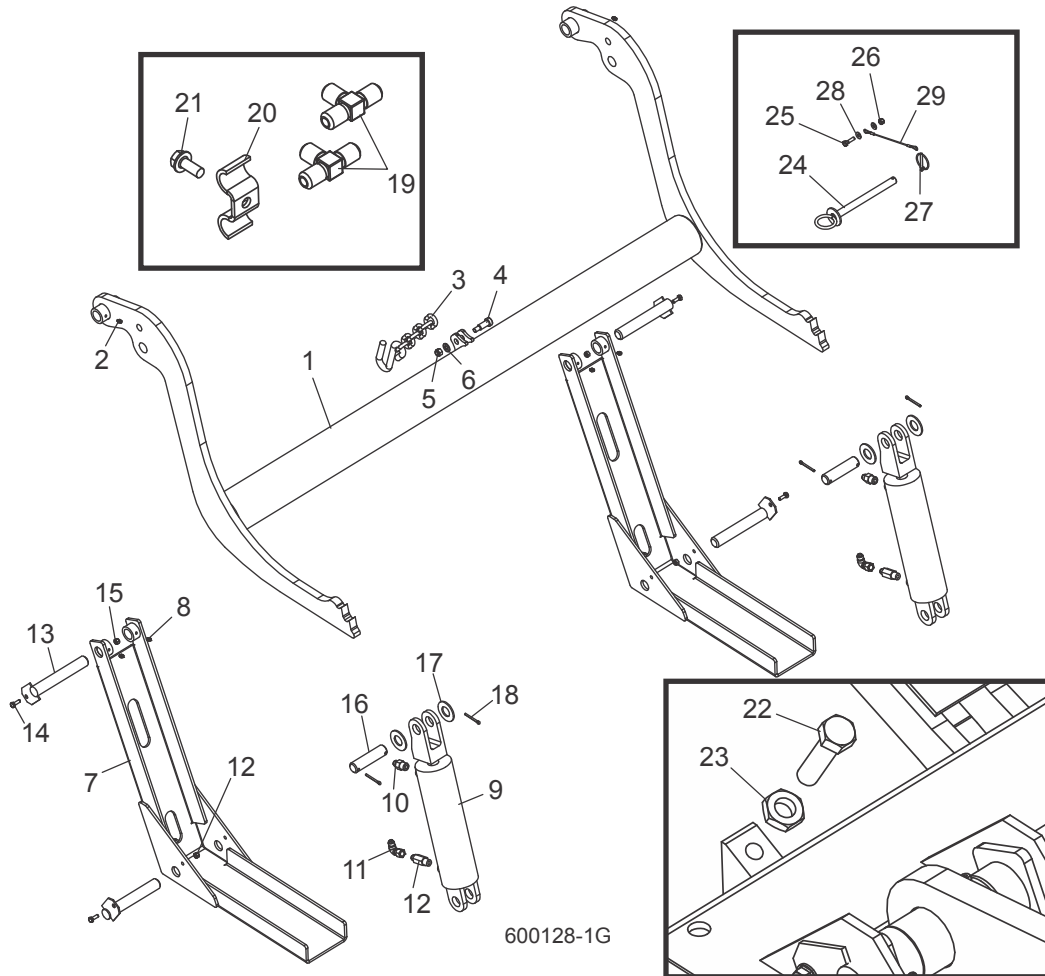

REF	DESCRIPTION (◆ Indicates Parts Available In Assemblies Only)	PART #	QTY.
	LOADER ASSEMBLY, HYDRAULIC LOG	034539	1
	Arm Assembly, Hydraulic Log Loading	036416	1
1	Arm Weldment, Log Loading	110372	1
2	Fitting, 3/16" Grease	P04107	2
3	Chain, 12-1/2 Inch Safety	110472	1
4	Bolt, 1/2 x 1 Shoulder Socket	F05008-146	1
5	Nut, 3/8-16 Hex Nyloc	F05010-10	1
6	Washer, 3/8 Flat SAE	F05011-3	1
7	Channel, Hydraulic Log Loading Foot	W09444	2
8	Fitting, 3/16" Grease	P04107	4
	Cylinder Assembly, Hydraulic Log Loader	038735	2
9	Cylinder, 8" X 3" Hydraulic (3/8" NPT Ports)	042754	1
	Seal Kit, 8" x 3" Hydraulic Cylinder	P12956	1

12

Bed Hydraulic System

Hydraulic Log Loader

10	Fitting, 3/8" NPT x 3/8" JIC Male Connector	016819	1	
11	Fitting, 3/8" JIC 90° Swivel Elbow	042756	1	
12	Fitting, 3/8NPT 6.5GPM Velocity Fuse	038734	1	
13	Pin, Loading Arm Mount	W09446	4	
14	Bolt, 1/4-20 x 3/4" Hex Head Full Thread	F05005-1	4	
15	Nut, 1/4-20 Hex Lock	F05010-69	4	
16	Pin, Loading Arm Cylinder Mount	S09251	2	
17	Washer, 1" SAE Flat	F05011-28	4	
18	Pin, 3/16" X 1 1/2" Cotter	F05012-23	4	
19	Fitting, 3/8" JIC Union 'T'	015487	1	
20	Clamp, 3/8" Hydraulic Hose	016041	6	
21	Bolt, 5/16-18 X 3/4" Hex Head Grade 5	F05006-102	6	
22	BOLT, 1/2-13 X 3" HEX HEAD FULL THREAD GRADE 5	F05008-7	2	
23	NUT, 1/2-13 JAM	F05010-31	2	
	ARM LOCK ASSEMBLY, LT70 WIDE LOADING (LT70 WIDE HEAD ONLY)	074208 ¹	1	
24	Pin Weldment, Arm Support	036692	1	
25	Bolt, 1/4-20 x 1" Hex Head Grade 5	F05005-101	1	
26	Nut, 1/4-20 Nylock	F05010-69	1	
27	Pin, Lynch 3/16" w/Chain	017604	1	
28	Washer, 1/4" SAE Flat	F05011-11	2	
29	Cable, 3/32" Dia. Board Return	016090	1	
	LINK, 1/2" THEADED CHAIN QUICK (LT70 WIDE HEAD ONLY)	074207	1	

¹ Removed (2) 074163 Loading Arm Lock Plates, (2) F05005-101 Bolts and (2) F05010-69 Nuts and moved location of lock pin to pass through hole in loading arm (LT70 Rev. B6.13/LT70Super Rev. A5.03).

12.10 Hydraulic Log Turner

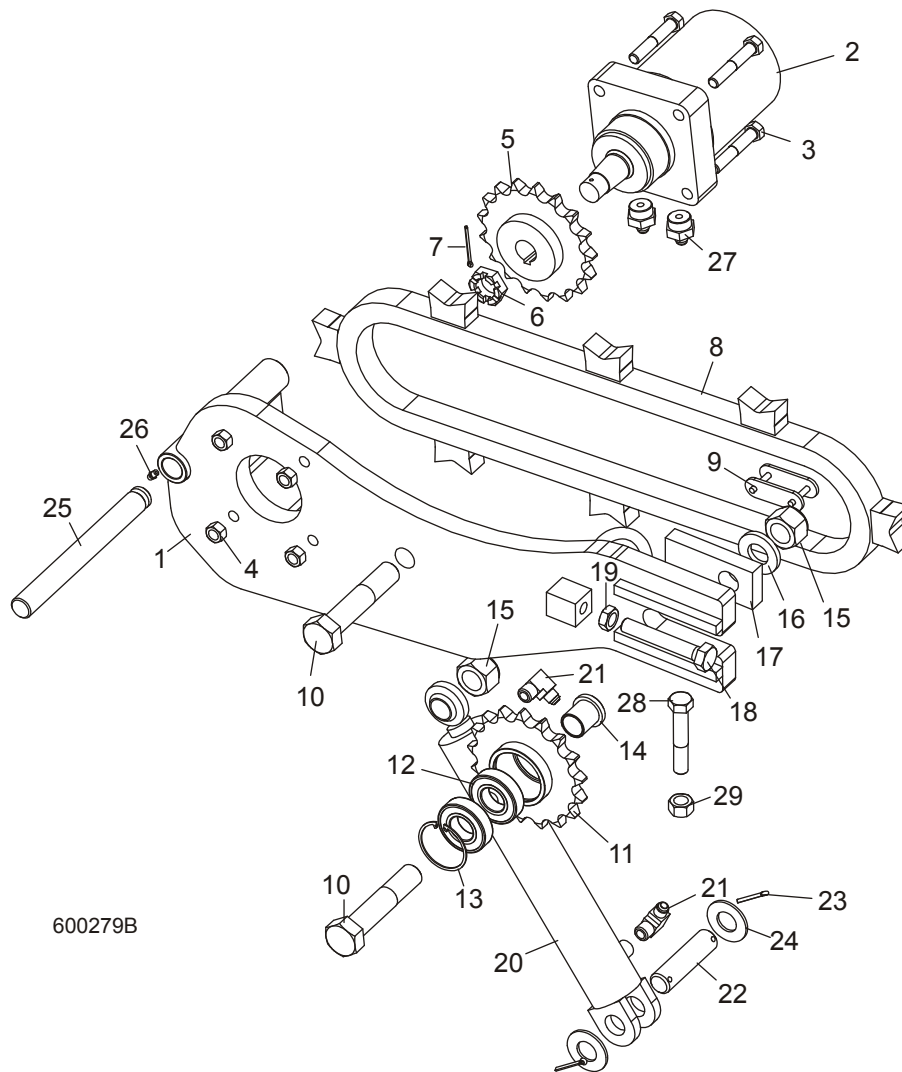

600279B

REF	DESCRIPTION (◆ Indicates Parts Available In Assemblies Only)	PART #	QTY.
	ARM ASSEMBLY, HYDRAULIC LOG TURNER	006095	1
1	Arm Weldment, Hydraulic Log Turner	006471	1
2	Motor, Hydraulic Log Turner	007331	1
	Kit, Seal Rebuild	061427	1
3	Bolt, 1/2-13 x 3" Hex Head Grade 5	F05008-23	4
4	Nut, 1/2-13 Hex Lock	F05010-3	4
5	Sprocket Weldment, Log Turner Drive	042192	1
6	Nut, Hydraulic Motor Castle	018741-2	1
7	Pin, 1/8" x 1 3/4" Cotter	F05012-43	1
8	Chain Weldment, Log Turner	006097	1

12

Bed Hydraulic System

Hydraulic Log Turner

9	Link, #2080H Master	016796	1	
10	Bolt, 1-8 x 5" Hex Head Grade 8	F05004-132	2	
	Sprocket Assembly, Idler	042193	1	
11	Sprocket Weldment, Idler	042191	1	
12	Bearing, 6206 25 Idler	P11035	2	
13	Ring, 62mm #472 DIN Inside Retaining	F04254-12	1	
14	Spacer, Idler Sprocket	042187	2	
15	Nut, 1-8 Hex Lock	F05010-109	2	
16	Washer, 1" ID x 2" OD x 1/4"	038749	1	
17	Plate, Log Turner Chain Tensioner	042188	1	
18	Bolt, 5/8-11 x 4" Hex Head Full Thread Grade 5	F05009-31	1	
19	Nut, 5/8-11 Hex Jam	F05010-82	1	
20	Cylinder, 2" x 10" Welded Rod End Hydraulic	128113 ¹	1	
21	Fitting, 3/8" NPT x 3/8" JIC 90° Elbow	016820	2	
22	Pin, 1" x 3.88"	S09251	1	
23	Pin, 3/16" x 1 1/2" Cotter	F05012-23	2	
24	Washer, 1" SAE Flat	F05011-28	2	
25	Rod, Grooved Turner Mount	006722	1	
26	Fitting, 1/4-28 Grease	P05060	1	
27	Fitting, #10 SAE x 3/8" JIC Straight	017640	2	
28	BOLT, 5/8-18 X 3 1/2" HEX HEAD BOLT FULL THREAD	F05009-16	1	
29	NUT, 5/8-18 HEX	F05010-50	1	

¹ 128113 replaced 034267 per ECN 37500 on 6/24/2020. Cylinder may have a vendor # of either 322009 or 322896. The 322009 uses seal kit # 061364; 322896 uses seal kit # 128258.

12.11 Hydraulic Log Side Supports (Front)

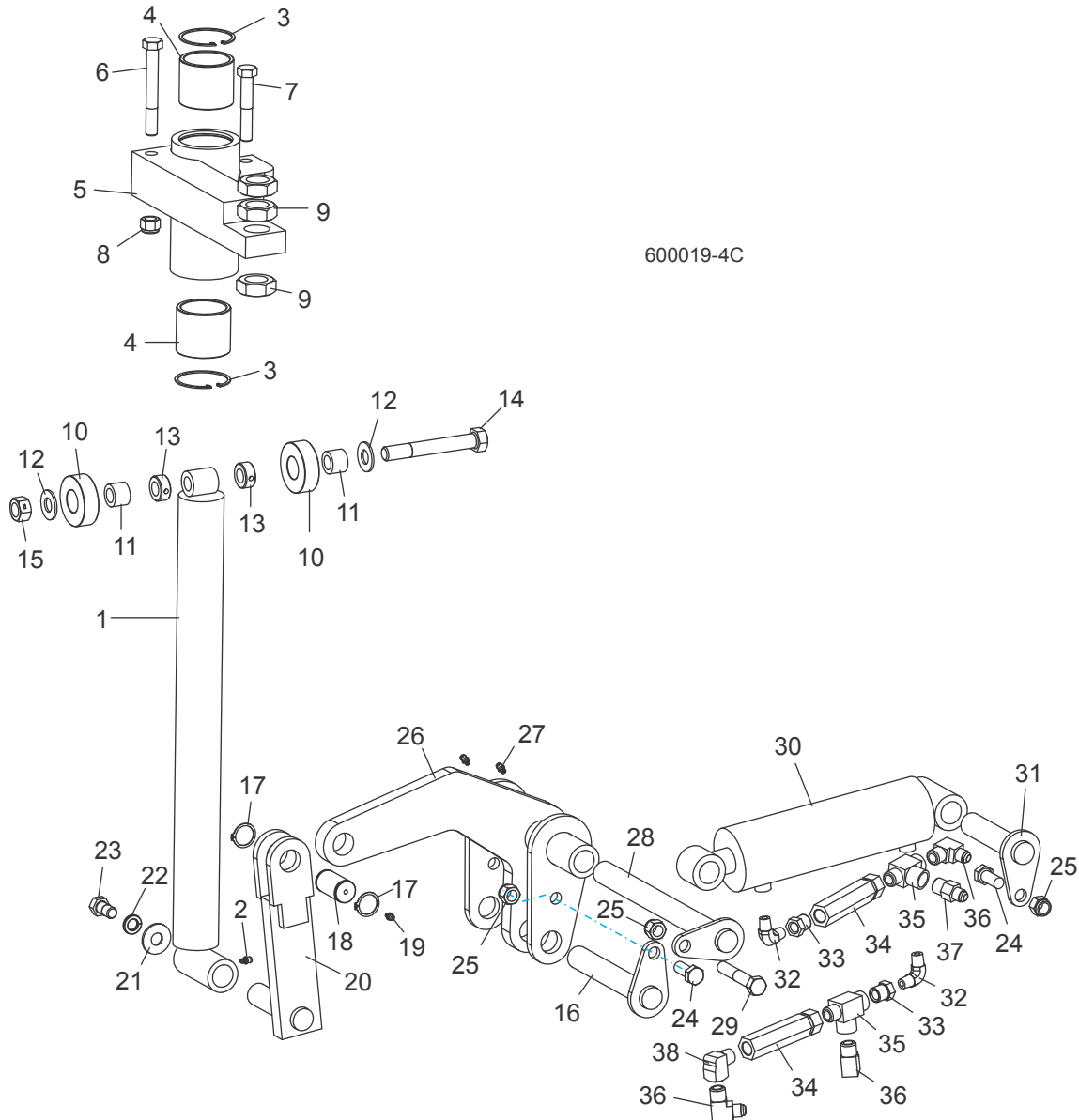

REF	DESCRIPTION (◆ Indicates Parts Available In Assemblies Only)	PART #	QTY.
	SUPPORT ASSEMBLY, VERTICAL HYDRAULIC SIDE	034732	1
1	Rod Weldment, Vertical Side Support	034704	1
2	Fitting, 3/16" Straight Grease	P04107	1
3	Ring, 62mm Din #472 Inside Retaining	F04254-12	2
4	Bushing, Side Support	042262	2
5	Mount Weldment, Vertical Side Support	034703	1
6	Bolt, 1/2-13 x 4" Hex Head Grade 5	F05008-78	1

12

Bed Hydraulic System Hydraulic Log Side Supports (Front)

7	Bolt, 1/2-13 x 3" Hex Head Grade 5	F05008-23	1	
8	Nut, 1/2-13 Hex Nylon Lock	F05010-8	2	
9	Nut, 1-14 Hex Jam	F05010-118	3	
	Roller Kit, Side Support	034733	1	
10	Roller, Side Support	016561	2	
11	Bushing, 5/8" x 1" x 3/4" Bronze	016560	2	
12	Washer, 5/8" SAE Flat	F05011-5	2	
13	Collar, 5/8" Lock	P05035	2	
14	Bolt, 5/8-11 x 4 1/2" Hex Head Grade 5	F05009-10	1	
15	Nut, 5/8-11 Hex Lock	F05010-4	1	
16	PIN WELDMENT, 6-5/16" PIVOT	106880 ¹	1	
	PIN ASSEMBLY, SIDE SUPPORT PIVOT	036053	1	
17	Ring, 1" 3100-100 Outside Retaining	F04254-15	2	
18	Pin, Grooved Pivot	034718	1	◆
19	Fitting, 3/16" Straight Grease	P04107	1	
20	PUSHER WELDMENT, LOWER SIDE SUPPORT	034711	1	
21	WASHER, 9/16" SAE FLAT	F05011-52	1	
22	WASHER, 1/2" SPLIT LOCK	F05011-9	1	
23	BOLT, 1/2-13 X 1" HEX HEAD	F05008-50	1	
24	BOLT, 1/2"-13 X 1 1/4" HEX HEAD GRADE 5	F05008-37	2	
25	NUT, 1/2-13 HEX NYLON LOCK	F05010-8	3	
26	ARM WELDMENT, SIDE SUPPORT FRONT LIFT	106868 ¹	1	
27	FITTING, 3/16" STRAIGHT GREASE	P04107	2	
28	PIN WELDMENT, 10 7/8" PIVOT	034728	1	
29	BOLT, 1/2-13 X 3" HEX HEAD GRADE 5	F05008-23	1	
30	CYLINDER, 2 1/2" X 6" X 1/4" NPT PORT HYDRAULIC	034736	1	
31	PIN WELDMENT, 4 3/8" PIVOT	034726	1	
32	FITTING, 1/4" NPT MALE PIPE ELBOW	P09140	2	
33	FITTING, 3/8" NPT X 1/4" NPT REDUCER	015490	2	
34	VALVE, SIDE SUPPORT SEQUENCE	015484	2	
35	FITTING, 3/8" NPT MALE RUN TEE	016822	2	
36	FITTING, 3/8" NPT X 3/8" JIC ELBOW	016820	3	
37	FITTING, 3/8" NPT X 3/8" JIC CONNECTOR	016819	1	
38	FITTING, 3/8" NPT STREET ELBOW	P05759	1	

¹ 106880 replaces 034727 5 1/4" Pin Weldment and 106868 replaces 034715 Lift Weldment to improve access to adjustment nuts (LT70 Rev. B6.13/LT70Super Rev. A5.03).

12.12 Hydraulic Log Side Supports (Rear)

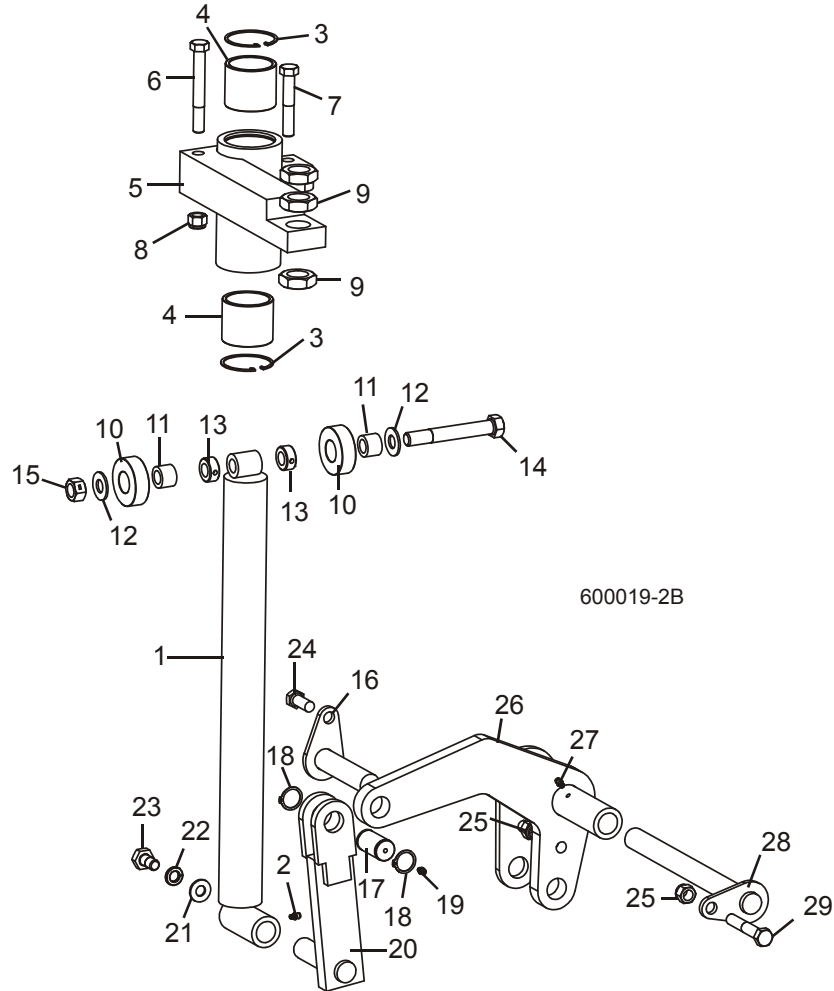

REF	DESCRIPTION (◆ Indicates Parts Available In Assemblies Only)	PART #	QTY.
	SUPPORT ASSEMBLY, VERTICAL HYDRAULIC SIDE	034732	1
1	Rod Weldment, Vertical Side Support	034704	1
2	Fitting, 3/16" Straight Grease	P04107	1
3	Ring, 62mm Din #472 Inside Retaining	F04254-12	2
4	Bushing, Side Support	042262	2
5	Mount Weldment, Vertical Side Support	034703	1
6	Bolt, 1/2-13 x 4" Hex Head Grade 5	F05008-78	1
7	Bolt, 1/2-13 x 3" Hex Head Grade 5	F05008-23	1
8	Nut, 1/2-13 Hex Nylon Lock	F05010-8	2
9	Nut, 1-14 Hex Jam	F05010-118	3
	Roller Kit, Side Support	034733	1
10	Roller, Side Support	016561	2
11	Bushing, 5/8" x 1" x 3/4" Bronze	016560	2

12

Bed Hydraulic System

Hydraulic Log Side Supports (Rear)

12	Washer, 5/8" SAE Flat	F05011-5	2	
13	Collar, 5/8" Lock	P05035	2	
14	Bolt, 5/8-11 x 4 1/2" Hex Head Grade 5	F05009-10	1	
15	Nut, 5/8-11 Hex Lock	F05010-4	1	
16	PIN WELDMENT, 4 3/8" PIVOT	034726	1	
	PIN ASSEMBLY, SIDE SUPPORT PIVOT	036053	1	
17	Pin, Grooved Pivot	034718	1	◆
18	Ring, 1" 3100-100 Outside Retaining	F04254-15	2	
19	Fitting, 3/16" Straight Grease	P04107	1	
20	PUSHER WELDMENT, LOWER SIDE SUPPORT	034711	1	
21	WASHER, 9/16" SAE FLAT	F05011-52	1	
22	WASHER, 1/2" SPLIT LOCK	F05011-9	1	
23	BOLT, 1/2-13 X 1" HEX HEAD	F05008-50	1	
24	BOLT, 1/2"-13 X 1 1/4" HEX HEAD GRADE 5	F05008-37	2	
25	NUT, 1/2-13 HEX NYLON LOCK	F05010-8	2	
26	ARM WELDMENT, VERTICAL SIDE SUPPORT REAR LIFT	034716	1	
27	FITTING, 3/16" STRAIGHT GREASE	P04107	1	
28	PIN WELDMENT, 10 7/8" PIVOT	034728	1	
29	BOLT, 1/2-13 X 3" HEX HEAD GRADE 5	F05008-23	1	

12.13 Hydraulic Log Side Supports (Link)

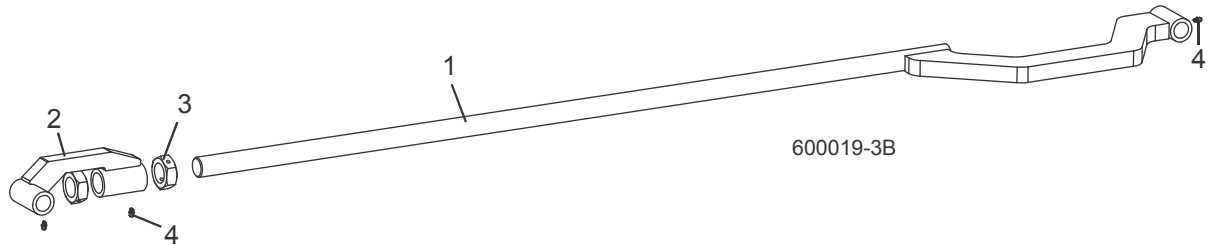

REF	DESCRIPTION (◆ Indicates Parts Available In Assemblies Only)	PART #	QTY.	
1	ROD WELDMENT, SIDE SUPPORT LINK	034725	1	
2	ARM WELDMENT, SIDE SUPPORT LINK	106869 ¹	1	
3	NUT, 1 1/4"-12 HEX JAM	F05010-100	2	
4	FITTING, 3/16" STRAIGHT GREASE	P04107	3	

¹ Replaces 034724 Link Arm Weldment to improve access to adjustment nuts (LT70 Rev. B6.13/LT70Super Rev. A5.03).

12.14 Hydraulic Log Clamp

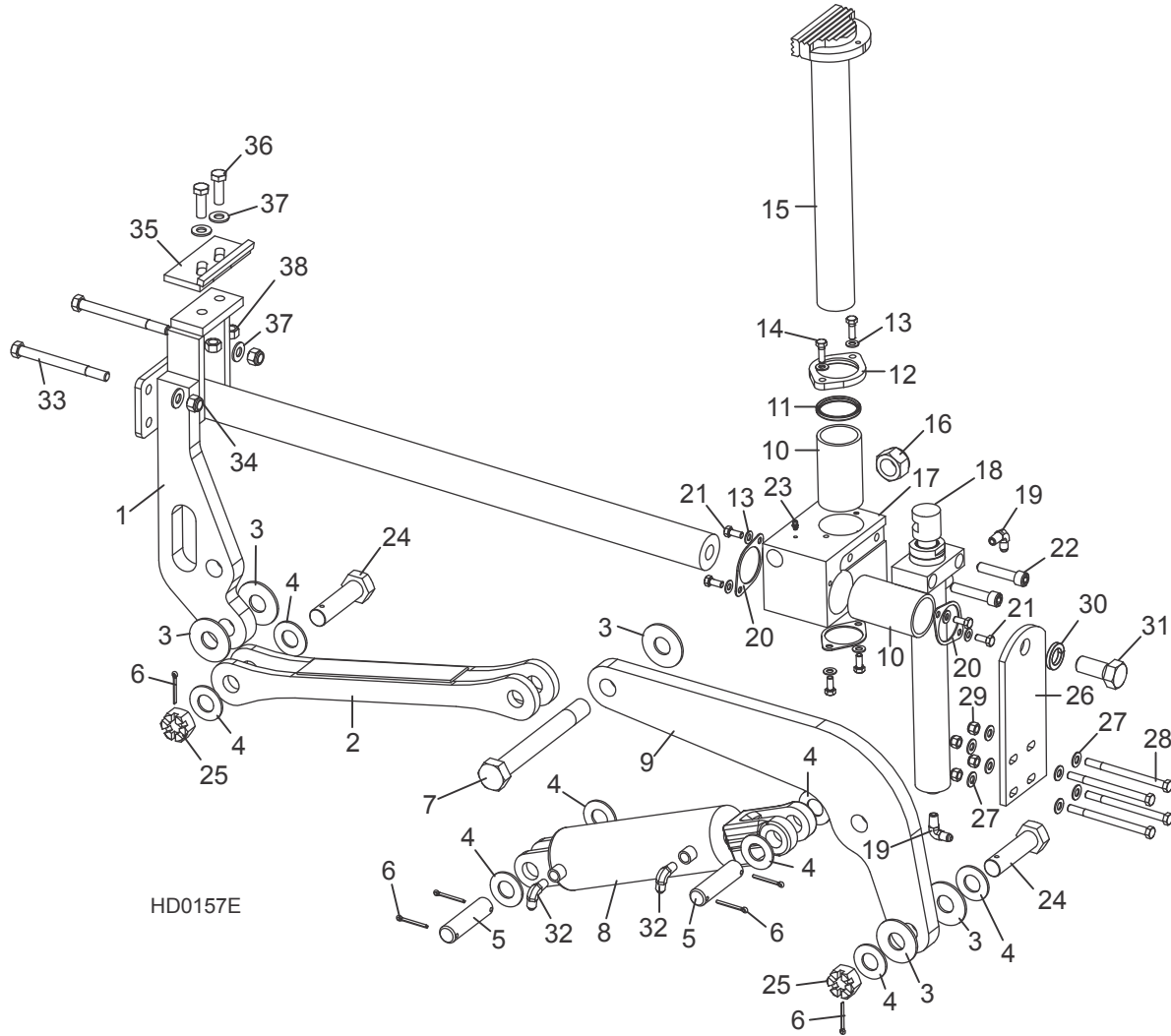

REF	DESCRIPTION (◆ Indicates Parts Available In Assemblies Only)	PART #	QTY.
	CLAMP ASSEMBLY, HYDRAULIC 2-PLANE	017264	1
1	Mount Weldment, Hydraulic Clamp Slide	017265	1
2	Link Weldment, Hydraulic Clamp	017267	1
3	Washer, 1/8" x 2 1/2" Hardened	015057	5
4	Washer, 1" SAE Flat	F05011-28	8
5	Pin, 1" x 3.88"	S09251	2
6	Pin, 3/16" x 1 1/2" Cotter	F05012-23	6
7	Bolt, 1-14 x 8 1/2" Hex Head Grade 8	015049	1
8	Cylinder, 3" x 7" Hydraulic	017275	1
	Seal Kit, Hydraulic Cylinder	P12956	1
9	Arm, Clamp Pivot	017274	1

10	Bushing, Clamp Slide	015088	2	
	Wiper Assembly, Vertical Clamp Rod	017271	1	
11	Wiper, Vertical Clamp Rod	017273	1	
12	Flange, Vertical Clamp Rod Wiper	017272	1	
13	Washer, 5/16" SAE Flat	F05011-17	8	
14	Bolt, 5/16-18 x 1" Hex Head	F05006-1	2	
15	Clamp Weldment, Vertical	015043	1	
16	Nut, 1-14 Nylon Lock	F05010-141	1	
17	Block, Hydraulic Clamp Slide	017270	1	
18	Cylinder Weldment, Vertical Clamp Hydraulic	015050	1	
	Seal Kit, Hydraulic Cylinder	016204	1	
	Instruction Sheet, Vertical Clamp Seal Replacement	016204-1009	1	
19	Fitting, 1/4" NPT x 1/4" JIC Elbow	P09142	2	
20	Retainer, Clamp Bushing	017242	3	
21	Bolt, 5/16-18 x 3/4" Hex Head	F05006-5	6	
22	Bolt, 1/2-13 x 2 1/2" Socket Head	F05008-39	2	
23	Fitting, 3/16" Straight Grease	P04107	1	
24	Bolt, 1-14 x 3 3/4" Hex Head Grade 8 w/Hole	015072	2	
25	Nut, 1-14 Slotted Hex	F05010-163	2	
26	Plate, Log Clamp Mount	015068	1	
27	Washer, 3/8" SAE Flat	F05011-3	8	
28	Bolt, 3/8-16 x 5" Hex Head	F05007-5	4	
29	Nut, 3/8-16 Hex Nylon Lock	F05010-10	4	
30	Washer, 7/8" Split Lock	F05011-46	1	
31	Bolt, 7/8-14 x 2" Hex Head Grade 5	F05014-2	1	
32	Fitting, 1/4" NPT - 3/8" JIC Elbow	015491	2	
33	Bolt, 1/2-13 x 5 1/2" Hex Head Grade 5	F05008-28	2	
34	Nut, 1/2-13 Hex Nylon Lock	F05010-8	2	
	Clamp Stop Kit, Hydraulic Log	K09485	1	
35	Plate, Clamp Stop	W09404	1	
36	Bolt, 1/2-13 X 1 1/2" Hex Head Grade 5	F05008-33	2	
37	Washer, 1/2" SAE Flat	F05011-2	2	
38	Nut, 1/2-13 Hex Lock	F05010-3	2	

12.15 Hydraulic Toe Board

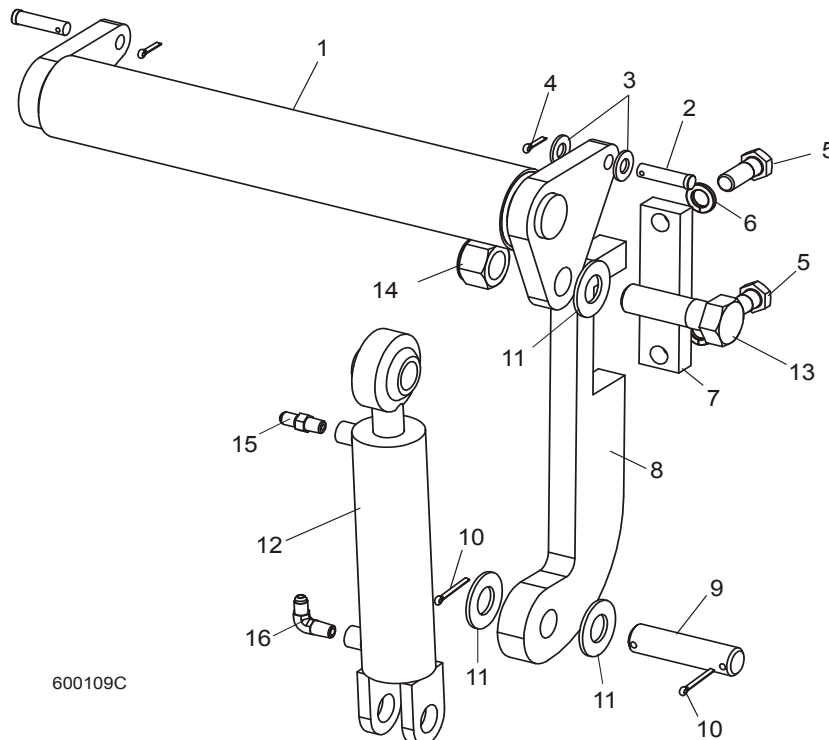

REF	DESCRIPTION (◆ Indicates Parts Available In Assemblies Only)	PART #	QTY.
1	TOE BOARD ASSEMBLY, HYDRAULIC	074842	2
2	PIN, 1/2-1 3/4 CLEVIS	F05012-82	4
3	WASHER, 1/2" SAE FLAT	F05011-2	4
4	PIN, 1/8 X 3/4" COTTER	F05012-3	4
5	BOLT, 5/8-11 X 1 3/4" HEX HEAD	F05009-33	4
6	WASHER, 5/8" SPLIT LOCK	F05011-27	4
7	PLATE, HYDRAULIC TOEBOARD MOUNT	S13023	2
8	BRACKET, HYDRAULIC TOEBOARD MOUNT	S13022	2
9	PIN, CYLINDER MOUNT	S09251	2
10	PIN, 3/16" X 1 1/2" COTTER	F05012-23	4
11	WASHER, 1" SAE FLAT	F05011-28	6
12	CYLINDER, 1 1/2" X 6" HYDRAULIC TOE BOARD	014482	2
	Seal Kit, 1 1/2" x 6" Hydraulic Cylinder	014547	1
13	BOLT, 1-8 X 3 1/4" HEX HEAD GRADE 5	F05009-51	2
14	NUT, 1-8 HEX NYLON LOCK	F05010-109	2
15	FITTING, 1/4" NPT X 1/4" JIC MALE	P09143	2
16	FITTING, 1/4" NPT X 1/4" JIC MALE ELBOW	P09142	2

SECTION 13 ACCESSORIES

LT70HD/LT70HD Wireless

REF	DESCRIPTION	MASTER	
	LATHE-MIZER (SEE MANUAL)	M1337	
	LATHE-MIZER TENON KIT (SEE MANUAL)	M1308	
	LOG DECK (SEE MANUAL)	M1120	
	SHINGLE LAP SIDER (SEE MANUAL)	M903	

14 Trailers

SECTION 14 TRAILERS

LT70HD/LT70HD Wireless

REF	DESCRIPTION	MASTER	
	ELECTRIC BRAKE (CLASS IV FOR DIESEL ONLY) (SEE MANUAL)	M1114	
	SUPER ELECTRIC BRAKE TRAILER OPTION (SEE MANUAL)	M797	
	SUPER SURGE BRAKE TRAILER OPTION (SEE MANUAL)	M795	

SECTION 15 MISCELLANEOUS

15.1 Replacement Manuals



REF	DESCRIPTION (◆ Indicates Parts Available In Assemblies Only)	PART #	QTY.
Wood-Mizer Product Information			
1	ALL-PRODUCTS CATALOG	PS750	1
Basic Sawmill Manuals			
2	TRU-SHARP BLADE HANDBOOK	M600	1
3	WOOD-MIZER GENERAL INFORMATION	M601	1
4	LT60HD/LT70HD OPERATOR'S MANUAL	M1667	1
5	LT70HD-WR WIRELESS OPERATOR'S MANUAL	M1669	1
6	LT60HD/70HD PARTS MANUAL	M1666	1
7	LT70HD-WR WIRELESS PARTS MANUAL	M1668	1
Power Option Manuals			
8	E25 MOTOR OPTION MANUAL	M1082	1
9	E30 MOTOR OPTION MANUAL	M1778	1
10	D51 ENGINE OPTION MANUAL	M1146	1
11	D55 ENGINE OPTION MANUAL	M1589	1
12	D62 ENGINE OPTION MANUAL	M1138	1
Trailer Option Manuals			
13	SUPER ELECTRIC BRAKE TRAILER OPTION	M797	1
14	SUPER SURGE BRAKE TRAILER OPTION	M795	1
Miscellaneous Option Manuals			
15	SHINGLE/LAPSIDER OPTION MANUAL	M621	1
16	OPERATOR'S SEAT OPTION MANUAL	M613	1
17	RESAW ATTACHMENT OPTION MANUAL	M263	1
18	BED EXTENSION OPTION MANUAL	M294	1
19	DEBARKER OPTION MANUAL (DC)	M1059	1
20	DEBARKER OPTION MANUAL (AC)	M1105	1
21	ACCUSET 2 OPTION MANUAL	M1521	1
22	LASER SIGHT OPTION MANUAL	M1081	1

23	LUBE-MIZER OPTION MANUAL	M885	1
24	LATHE-MIZER OPTION MANUAL	M1337	1
Electrical Diagrams			
25	E25-H ELECTRICAL INFORMATION	M1088	1
26	E25-L ELECTRICAL INFORMATION	M1090	1
27	E25-C ELECTRICAL INFORMATION	M1092	1
28	E25-H-WR WIRELESS ELECTRICAL INFORMATION	M1558	1
29	E25-L-WR WIRELESS ELECTRICAL INFORMATION	M1559	1
30	E25-C-WR WIRELESS ELECTRICAL INFORMATION	M1557	1
31	E30-H-WR WIRELESS ELECTRICAL INFORMATION	M1780	1
32	D51/D62 ELECTRICAL INFORMATION	M1141	1
33	D55 ELECTRICAL INFORMATION	M1590	1
34	D51/D62-WR WIRELESS ELECTRICAL INFORMATION	M1556	1
35	D55-WR WIRELESS ELECTRICAL INFORMATION	M1592	1

15.2 Tools

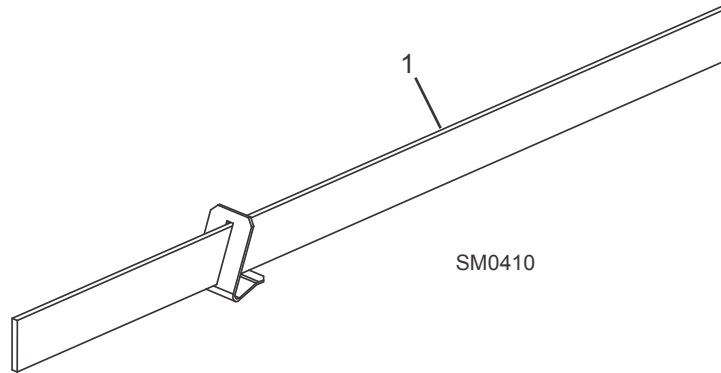

REF	DESCRIPTION (◆ Indicates Parts Available In Assemblies Only)	PART #	QTY.	
1	ALIGNMENT TOOL, BLADE GUIDE	LTBGAT	1	

INDEX

A

autoclutch assembly 4-5, 4-7

B

battery box 8-16

bed rails

- front/rear 11-1
- middle front 11-3
- middle rear 11-4
- pivot 11-8, 11-10

belt tensioner 4-2

blade guide arm
drive 2-13

blade guides
drive side 2-7
idle side 2-1
throat screw 4-1

blade tensioner 3-7, 3-9, 3-12

blade wheels
drive side 3-1
idle side 3-3

board return 4-9

board return table 11-7

brake assembly 4-4

C

control box 8-1, 8-4, 8-7
circuit breakers 8-11
drum switches 8-10
front panel & harnesses 8-12, 8-14

covers

blade housing 4-13

D

debarker

blade housing 7-17, 7-18
complete assembly 7-1, 7-2, 7-1, 7-2
cutter head (AC) 7-11, 7-15
cutter head (DC) 7-11, 7-12, 7-14
frame assembly 7-3, 7-5
in/out motor 7-7, 7-9
spring arm 7-20

debarker wire box/hole plugs 4-16

decals

frame 11-15, 11-16
saw head 4-12

E

engine options 5-1

F

feed chain 10-5

fuse box 8-18

H

hydraulic

- control box (230/460V AC) 12-11
- control box (575V AC) 12-13
- hoses 12-1
- log clamp 12-28
- log loader 12-19
- log turner 12-21
- power strip 12-15
- power strip (AC) 12-17
- power strip (DC) 12-15
- pump box (230/460V AC) 12-6
- pump box (575V AC) 12-9
- pump box (DC) 12-3
- side supports 12-23
- side supports (link) 12-27
- side supports (rear) 12-25
- toe board 12-30

M

- manuals 15-1, 15-3

O

- options, accessories and trailers 6-1, 13-31, 14-1
- outfeed table option 11-17

P

- parts list
 - how to use 1-1
- power feed 10-3

R

- rest pin 11-14

S

- sawdust chute 4-15
- side supports 11-11

T

- tensor de hoja 3-5
- track rollers
 - lower 10-6
 - upper 10-1

U

- up/down
 - assist 9-7
 - blade scales 9-3
 - chain & sprockets 9-4
 - drive 9-5

W

- water lube
 - bottle/tray 4-10